



Model

1278-8

Revision 2 Updated October 30, 2025

Technical Manual



Atlanta Attachment Company, Inc.

Confidential and Proprietary Information

The materials contained herein are confidential and proprietary information of Atlanta Attachment Company. In addition to any confidentiality and non-disclosure obligations that currently exist between you and Atlanta Attachment Company, your use of these materials serves as an acknowledgment of the confidential and proprietary nature of these materials and your duty not to make any unauthorized use or disclosure of these materials.

All materials contained herein are additionally protected by United States Copyright law and may not be used, disclosed, reproduced, distributed, published or sold without the express written consent of Atlanta Attachment Company, which consent may be withheld in Atlanta Attachment Company's sole discretion. You may not alter or remove any copyright, trademark or other notice from copies of these materials.

IMPORTANT

It is important to read and understand the information contained within this manual before attempting to operate the machine. Atlanta Attachment Co., Inc. shall not be held liable for damage resulting from misuse of the information presented within, and reserves the right to change the information contained within, without prior notification.

Patents & Patents Pending

The sale of this product does not sell or otherwise transfer any license or other rights under any U.S. Patent or other corresponding foreign patent.

This equipment is manufactured under one or more of the following patents:

4,280,421 • 4,432,294 • 4,466,367 • 4,644,883 • 5,134,947 • 5,159,889 • 5,203,270 •
5,373,798 • 5,437,238 • 5,522,332 • 5,524,563 • 5,562,060 • 5,634,418 • 5,647,293
•5,657,711 • 5,743,202 • 5,865,135 • 5,899,159 • 5,915,319 • 5,918,560 • 5,924,376
•5,979,345 • 6,035,794 • 6,055,921 • 6,202,579 • 6,279,869 • 6,295,481 • 6,494,225
•6,523,488 • 6,574,815 • 6,802,271 • 6,834,603 • 6,968,794 • 6,994,043 • 7,543,364
•7,574,788 • 7,647,876 • 7,735,439

Foreign Patents: 9-520,472 • 0,537,323 • 92,905,522.6 • 96,936,922.2 • 2,076,379 •
2,084,055

Other U.S. and Foreign Patents Pending.

Contents

CONFIDENTIAL AND PROPRIETARY INFORMATION	0
CONTENTS.....	1
SAFETY INSTRUCTION	0
Important Notices.....	3
Maintenance	5
1. INSTALLATION	7
1.1. PARTS AND COMPONENTS.....	7
1.2. TECHNICAL DATA	8
1.3. PRODUCTION	8
1.4. MACHINE CLASSES AND CODES	8
1.5. OPTIONS & CLASSES	9
1.6. FOOTPRINT.....	10
1.7. MACHINE IDENTIFICATION LABEL	10
1.8. INSTALLATION & SET UP.....	10
1. V-belt.....	10
2. Thread Stand	10
3. Computer Boxes	11
4. Waste System	11
5. Stacker	11
6. Sewing Head Lubrication.....	11
7. Air Supply.....	12
8. Power Connection.....	12
9. Power “ON”.....	12
10. Electric Eyes	12
11. Stepping Motors	12
12. Footlift Pedal.....	12
13. Sewing Head	13
14. Check Folder	13
15. Check Guiding & Rollers	13
16. Set up First Garment	13
2. OPERATION	14
2.1. INDIVIDUAL COMPONENTS	14
2.1.1. Control Panel.....	15
1. Power On	15
2. Emergency Stop	15
3. Serial Bus control.....	15
2.1.2. Footlift Pedal	15
2.1.3. Start Sew Pedal.....	15
2.1.4. Left Roller Assembly	15
2.1.5. Presser Roller.....	15
2.1.6. Right Roller Assembly	16
2.1.7. Lower Guiding	16
2.1.8. Waste System	16
2.1.9. Sewing Motor Control Boxes.....	17
1. Efka	17
2. Panasonic	17
2.1.10. Stepping Motors Control Boxes.....	17
2.2. TOUCH-SCREEN	18
2.2.1. General Operation.....	18
2.2.2. Available Menus 1278-8-G.....	19
1. AUTOMATIC.....	20

2.3.	THREADING	23
2.3.1.	Thread Break Detectors	23
1.	Lopper Thread Sensor	23
2.	Needle Thread Sensor	23
2.4.	SEWING	24
2.4.1.	Sequence	24
	Stage 1 Loading.....	24
	• The garment is loaded onto the rollers until the right electric eye is fully covered.	24
	Stage 2 Jogging.....	24
	Stage 3 Seam Start	24
	Stage 4 Seam End	24
	Stage 5 Stacking.....	25
2.5.	SIZE ADJUSTMENTS	25
2.5.1.	Left roller	25
2.5.2.	Pre-feed time	25
2.6.	MAINTENANCE	26
2.6.1.	General Safety Instructions	26
2.6.2.	Preparation.....	26
	Preventive Maintenance 8 Hrs.	27
3.	SERVICE.....	28
3.1.	LOCKOUT/TAGOUT PROGRAM	28
3.2.	MECHANICAL	29
3.2.1.	Assemblies Alignment	29
1.	Left Roller.....	29
1.	Right-Hand Roller	29
2.	Tension Roller.....	30
3.2.2.	Presser Foot Height	30
3.2.3.	Seam	31
1.	Seam Margin.....	31
2.	Cutting Margin.....	31
3.	Seams With flip mode disabled	31
4.	Seams with Flip Mode Available	32
3.2.4.	Adjustments.....	33
1.	Changing Seam Margin	33
2.	Changing Stitch Length.....	34
3.2.5.	Folder Flag	36
3.2.6.	Electric Eyes.....	37
3.3.	PNEUMATIC	38
3.3.1.	Air Maintenance Unit FR	38
1.	Pressure Relief Valve	38
2.	Pressure Regulator	38
3.	Air Filters	38
3.3.2.	Solenoid Valve Stacking Manifold	39
3.3.3.	Air Pressure Switch	39
3.3.4.	Waste Venturi.....	39
3.3.5.	Pressure Regulator	40
1.	Tension Bar Cylinder	40
2.	Lower Guide Cylinder	40
3.3.6.	Blowers.....	41
	In front of guide.....	41
	Outer Uncurl Jets.....	41
	Inner Uncurl jets.....	41
	In front of the foot.....	42
3.4.	ELECTRICAL.....	43
3.4.1.	Ground	43
3.4.2.	Main Circuit Breaker.....	43

3.4.3.	Main Power Contactor.....	43
3.4.4.	Knife Switch.....	43
3.4.5.	Electric Eyes.....	44
	Raw Edge Eye #1:.....	44
	Folded Edge Eye #2:.....	44
	Upper Guide Eye #3:.....	44
	Hem Detect Eye #4:.....	44
	Eye Sensor Adjustment.....	45
	Reflective Tape Maintenance.....	45
3.4.6.	Fiber Optic Eye.....	45
3.4.7.	Tension Sensor Switch.....	45
3.4.8.	Thread Break Detectors.....	46
3.	Lopper Thread Sensor.....	46
4.	Needle Thread Sensor.....	46
3.4.9.	Stepping Motors.....	47
1.	Rollers Motors.....	47
2.	Lower Edge Guide.....	47
3.	Speed of Feed vs. Speed of Rollers.....	48
3.4.10.	Stepping Motor Control Box.....	49
1.	JOG button.....	49
2.	Thumbwheels.....	49
3.	Potentiometer.....	49
4.	Jumpers.....	49
5.	Power.....	50
3.4.11.	Secondary Stepping Motor Control Box.....	50
3.4.12.	Efka Sewing Motor.....	51
1.	Programming the Code Number.....	51
2.	Parameter Settings EFKA DC1500.....	51
3.4.13.	Panasonic Motor Sewing Motor.....	52
1.	Programming D9 Motor.....	52
2.	Programming D7 Motor.....	53
3.5.	SERIAL BUS.....	54
3.5.1.	Touch Screen.....	54
1.	Calibration.....	54
2.	Installation.....	55
3.5.2.	Modules.....	56
1.	Program Module...4080-150.....	56
2.	Module Data...4080-930.....	56
3.	Output Module...4080-140.....	56
4.	Input Module...4080-110.....	56
5.	Input Module...4080-120.....	56
6.	Output Module...4080-130.....	56
3.5.3.	Program Update.....	57
3.5.4.	Technical Screens 1278-8-H Software.....	58
1.	ADVANCED FUNCTIONS.....	58
2.	MACHINE SETUP.....	64
3.5.5.	Technical Screens 1278-8G Software.....	66
	Expiration Count 911.....	72
1.	Unlock Procedure.....	72
3.6.	MAINTENANCE.....	74
3.6.1.	General Safety Instructions.....	74
	Preventive Maintenance 40 Hrs.....	75
	Preventive Maintenance 960 Hrs.....	77
3.7.	TROUBLESHOOTING.....	78
3.7.1.	Screen Messages.....	78
3.7.2.	Seam.....	82
3.7.3.	Electrically.....	83

3.7.4. Efka Controller Error.....	85
1. Flow Chart EFKA Error E1.....	86
3.7.5. Panasonic D9 Controller Errors.....	87
STATEMENT OF WARRANTY.....	88
Manufactured Products	88
Terms and Conditions:	88
What Is Covered.....	88
What Is Not Covered	88
TRAINING	89
NOTES:	91
INDEX	92

Safety Instruction



This part of the Instruction Material is provided for the safe use of your equipment. It contains important information to help work safely with the unit and describes the dangers inherent in machinery. Some of these dangers are obvious, while others are less evident.

Mandatory Information

All persons operating and/or working on the Workstation should read and understand all parts of the Safety Instructions. This applies, in particular, for persons who only operate and/or work on the unit occasionally (e.g. for maintenance and repair). Persons who have difficulty reading must receive particularly thorough instruction.

Scope of the Instruction Material

The Instruction Material comprises:

- Safety information
- Operator Instructions
- Electrical and Pneumatic diagrams

And may also include;

- A list of recommended spare parts
- Instruction Manual(s) for components made by other manufacturers
- The layout and installation diagram containing information for installation

Intended Use

Our machines are designed and built in line with the state of the art and the accepted safety rules. However, all machines may endanger the life and limb of their users and/or third parties and be damaged or cause damage to other property, particularly if they are operated incorrectly or used for purposes other than those specified in the Instruction Manual.

Exclusion of Misuse



Non-conforming uses include, for example, using the equipment for something other than it was designed for, as well as operation without duly installed safety equipment. The risk rests exclusively with the end user.

Conforming use of the machine includes compliance with the technical data, information and regulations in all parts of the complete Instruction Material, as well as compliance with the maintenance regulations. All local safety and accident prevention regulations

must also be observed.

Liability

The machine should only be operated when in perfect working order, with due regard for safety and the potential dangers, as well as in accordance with the Instruction Material. Faults and malfunctions capable of impairing safety should be remedied immediately. We cannot accept any liability for personal injury or property damage due to operator errors or non-compliance with the safety instructions contained in this booklet. The risk rests exclusively with the end user.

The Instruction Material should always be kept near the machine so that it is accessible to all concerned. The local, general, statutory and other binding regulations on accident prevention and environmental protection must also be observed in addition to the Instruction Material. The operating staff must be instructed accordingly. This obligation also includes the handling of dangerous substances and provision/use of personal protective equipment.

The Instruction Material should be supplemented by instructions, including supervisory and notification duties with due regard for special operational features, such as the organization of work, work sequences, the personnel deployed, etc.

Safety

The personnel's awareness of the dangers and compliance with the safety regulations should be checked at irregular intervals.

Choice and Qualification of Personnel

Ensure that work on the machine is only carried out by reliable persons who have been appropriately trained for such work - either within the company, by our field staff or at our office - and who have not only been duly appointed and authorized, but are also fully familiar with the local regulations. Work on the machine should only be carried out by skilled personnel, under the management and supervision of a duly qualified engineer.

This not only applies when the machine is used for production, but also for special work associated with its operation (start-up and maintenance), especially when it concerns work on the hydraulic or electrical systems, as well as on the software/serial bus system.

Training

Everyone working on or with the machine should be duly trained and informed with regard to correct use of the safety equipment, the foreseeable dangers which may arise during operation of the machine and the safety precautions to be taken. In addition, the personnel should be instructed to check all safety mechanisms at regular intervals.

Responsibilities

Clearly define exactly who is responsible for operating, setting-up, servicing and repairing the machine. Define the responsibilities of the machine operator and authorize him to refuse any instructions by third parties if they run contrary to the machine's safety. This applies in particular for the operators of machines linked to other equipment. Persons receiving training of any kind may only work on or with the machine under the constant supervision of an experienced operator. Note the minimum age limits permitted by law.

A Word to the Operator

The greatest danger inherent in our machines: is that of fingers, hands or loose clothing being drawn into a machine by live, coasting or rotating tools or assemblies or of being cut by sharp tools or burned by hot elements.

Always be conscious of these dangers!

Safety Equipment on the Machines



All machines are delivered with safety equipment, which shall not be removed or bypassed during operation.

The correct functioning of safety equipment on machines and systems should be checked every day and before every new shift starts, after maintenance and repair work, when starting up for the first time and when restarting (e.g. after prolonged shutdowns).

If safety equipment has to be dismantled for setting-up, maintenance or repair work, such safety equipment shall be replaced and checked immediately upon completing the maintenance or repair work.

All protective mechanisms shall be fitted and fully operational whenever the machine is at a standstill or if it has been shut down for a longer period of time.

Damage

If any changes capable of impairing safety are observed in the machine or its mode of operation, such as malfunctions, faults or changes in the machine or tools, appropriate steps must be taken immediately, the machine switched off and a proper lockout tagout procedure followed. The machine should be examined for obvious damage and defects at least once per

Safety

shift. Damage found shall be immediately remedied by a duly authorized person before resuming operation of machine.

The machine should only be operated when in perfect working order and when all protective mechanisms and safety equipment, such as detachable protective mechanisms, emergency STOP systems, etc. are in place and operational.

Faults or Errors

The machine must be switched off and all moving or rotating parts allowed to come to a standstill and secured against accidental restart before starting to remedy any faults or errors.

Signs on the Machine

Safety and danger signs on the machine should be observed and checked at regular intervals to ensure that they are complete and undamaged. They should be clearly visible and legible at all times.

Clothing, Jewelry, Protective Equipment

Long loose hair, loose-fitting clothes, gloves and jewelry, including rings, should be avoided in order to avoid injuries due to being caught, drawn in and wound up inside the machine.

Protective Eyewear

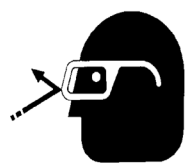

Protective eyewear that has been tested by the local authorities should be worn whenever there is a possibility of loose or flying objects or particles such as when cleaning the machine with compressed air.

Tools

Always count the number of tools in your possession before starting work on the machine. This will allow you to check that no tools have been left behind inside the machine. Never leave a tool in the machine while working.

Oils, Lubricants, Chemicals

Note the applicable safety regulations for the product used.

No Smoking, Fire, Explosion Hazard

Smoking and open flame (e.g. welding work) should be prohibited in the production area due to the risk of fire and explosions.

Workplace

A clear working area without any obstructions whatsoever is essential for safe operation of the machine. The floor should be level and clean, without any waste.

The workplace should be well lit, either by the general lighting or by local lights.

Emergency STOP

The emergency STOP buttons bring all machine movements to a standstill. Make sure you know exactly where they are located and how they work. Try them out. Always ensure easy access to the nearest emergency STOP button while working on the machine.

First Aid

1. Keep calm even when injured.
2. Clear the operator from the danger zone. The decision of what to do and whether to seek additional assistance rests entirely with you, particularly if someone has been trapped.
3. Give First Aid. Special courses are offered by such organizations as the employers' liability insurance association. Your colleagues should be able to rely on you and vice versa.
4. Call an ambulance. Do you know the telephone numbers for the ambulance service, police and fire service?

Important Notices

Reporting and Fighting Fires

Read the instructions posted in the factory with regard to reporting fires and the emergency exits. Make sure you know exactly where the fire extinguishers and sprinkler systems are located and how they are operated. Pass on the corresponding information to the firemen when they arrive. Ensure there are enough signs to avoid fire hazards.

The following fire extinguishers may be used:

- Dry powder extinguishers, ABC fire-extinguishing powder.
- Carbon dioxide fire extinguishers to DIN 14461 for electronic components. Great care must be exercised when using carbon dioxide fire extinguishers in confined, badly ventilated rooms (see DIN 14406 and 14270).

Isolate the machine from the power supply if a fire breaks out. Do not use water on burning electrical parts until it is absolutely certain that they have been completely disconnected from the power supply. Burning oils, lubricants, plastics and coatings on the machine can give off gases and vapors that may be harmful to your health.

A qualified person should be consulted to repair the damage after a fire.

Electrical Power Supply

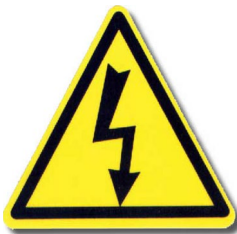

Before undertaking any maintenance or repair work on the machine, switch off the electrical power to the machine at the main source and secure it with a padlock so that it cannot be switched on again without authorization.

In practice, this may mean that the technician, electrician and operator all attach their own padlock to the master switch simultaneously so that they can carry out their work safely. Locking extension plates should be available for multiple locks if required. The primary purpose for a lockout/tagout

procedure is to protect workers from injury caused by unexpected energizing or start-up of equipment.

Energy sources (electrical/pneumatic/hydraulic, etc.) for the equipment shall be turned off or disconnected and the switches locked or labeled with a warning tag. It is the responsibility of the employer to establish control procedures. Follow lockout/tagout procedures before, setup and/or any service or maintenance work is performed, including lubrication, cleaning or clearance of jams.

Caution: The machine is still not completely de-energized even when the master switch is off.

- Electricity - The machine is always isolated from the electrical power supply whenever the master switch has been switched off. However, this does not apply for the power supply in the control cabinet, nor for equipment that does not draw its power via the master switch.

- Pneumatic / hydraulic energy - Almost all our machines carry compressed air. In addition to switching off the master switch, the air supply must also be disconnected and the machine checked to ensure it is depressurized before starting any work on the machine; otherwise the machine may execute uncontrolled movements.

- Kinetic energy - Note that some motors or spindles, for example, may continue to run or coast run on after being switched off.

- Potential energy - Individual assemblies may need to be secured if necessary for repair work.

Safety

Delivery of the Machine/Packaging

Note any markings on the packaging, such as weights, lifting points and special information. Avoid temperature fluctuations. Condensation may damage the machine.

Transport Damage

The packaging and machine must immediately be examined for signs of damage in transit. Such damage must be reported to the shipper/transporter within the applicable time limits. Contact Atlanta Attachment Company and/or your transport insurer immediately, if signs of damage are visible. Never operate a damaged machine.

Interim Storage

If the machine has to be stored temporarily, it must be oiled or greased and stored in a dry place where it is protected from the weather in order to avoid damage. A corrosion-inhibiting coating should be applied if the machine has to be stored for a longer period of time and additional precautions taken to avoid corrosion.

Transporting the Machine

Disconnect the machine from all external connections and secure any loose assemblies or parts. Never step under a suspended load. When transporting the machine or assemblies in a crate, ensure that the ropes or arms of a forklift truck are positioned as close to the edge of the crate as possible. The center of gravity is not necessarily in the middle of the crate. Note the accident prevention regulations, safety instructions and local regulations governing transport of the machine and its assemblies.

Only use suitable transport vehicles, hoisting gear and load suspension devices that are in perfect working order and of adequate carrying capacity. Transport should only be entrusted to duly qualified personnel.

Never allow the straps to rest against the machine enclosure and never push or pull sensitive parts of the machine. Ensure that the load is always properly secured. Before or immediately after loading the machine, secure it properly and affix corresponding warnings.

All transport guards and lifting devices must be removed before the machine is started up again. Any parts that are to be removed for transport must be carefully refitted and secured before the machine is started up again.

Workplace Environment

Our machines are designed for use in enclosed rooms: Permissible ambient temperature approx. 5 - 40 °C (40 - 104 °F). Malfunctions of the control systems and uncontrolled machine movements may occur at temperatures outside this range.

Protect against climatic influences, such as electrostatic charges, lightning strikes, hail, storm damage, high humidity, salinity of the air in coastal regions.

Protect against influences from the surroundings: no structure-borne vibrations, no grinding dust, or chemical vapors.

Protect against unauthorized access.

Ensure that the machine and accessories are set up in a stable position.

Ensure easy access for operation and maintenance (Instruction Manual and layout diagram); also verify that the floor is strong enough to carry the weight of the machine.

Local Regulations

Particular attention must be paid to local and statutory regulations, etc. when installing machines and the plant (e.g. with regard to the specified escape routes). Note the safety zones in relation to adjacent machines.

Safety

Maintenance

General Safety Instructions

The machine shall be switched off, come to a standstill and be secured so that it cannot be switched on again inadvertently before starting any maintenance work whatsoever. Use proper lockout/tagout procedures to secure the machine against inadvertent startup.

Remove any oil, grease, dirt and waste from the machine, particularly from the connections and screws, when starting the maintenance and/or repair work. Do not use any corrosive-cleaning agents. Use lint-free rags.

Retighten all screw connections that have to be loosened for the maintenance and repair work. Any safety mechanisms that have to be dismantled for setting-up, maintenance or repair purposes must be refitted and checked immediately after completing the work.

Maintenance, Care, Adjustment

The activities and intervals specified in the Instruction Manual for carrying out adjustments, maintenance and inspections must be observed and parts replaced as specified.

All hydraulic and pneumatic lines should be examined for leaks, loose connections, rubbing and damage whenever the machine is serviced. Any defects found must be remedied immediately.

Waste, Disassembly, Disposal

Waste products should be cleared from the machine as soon as possible as not to create a fire hazard.

Ensure that fuels and operating lubricants, as well as replacement parts are disposed of in a safe and ecologically acceptable manner. Note the local regulations on pollution control.

When scrapping (disassembling) the machine and its assemblies, ensure that these materials are disposed of safely. Either commission a specialist company familiar with the local regulations or note the local regulations when disposing of these materials yourself. Materials should be sorted properly.

Repair

Replacement Parts

We cannot accept any liability whatsoever for damage due to the use of parts made by other manufacturers or due to unqualified repair or modification of the machine.

Repair, Electrical

The power supply must be switched off (master switch off) and secured so that it cannot be switched on again inadvertently before starting any work on live parts.

Those parts of the machine and plant on which inspection, maintenance or repair work is to be carried out must be isolated from the power supply, if specified. The isolated parts must first be checked to determine that they are truly de-energized before being grounded and short-circuited. Adjacent live parts must also be isolated.

The protective measures implemented (e.g. grounding resistance) must be tested before restarting the machine after all assembly or repair work on electric parts.

Signal generators (limit switches) and other electrical parts on the safety mechanisms must not be removed or bypassed. Only use original fuses or circuit overloads with the specified current rating. The machine must be switched off immediately if a fault develops in the electrical power supply.

The electrical equipment of our machines must be checked at regular intervals and any defects found must be remedied immediately.

If it is necessary to carry out work on live parts, a second person should be on hand to operate the emergency OFF switch or master switch with voltage release in the event of an emergency. The working area should be cordoned off and marked by a warning sign. Only use electrically insulated tools.

Safety

Ventilation/Hazardous Gases

It is the end users responsibility to ensure adequate ventilation is provided to exhaust any and all noxious or hazardous gases that may be present in the working environment.

Hydraulic and Pneumatic Systems

Work on hydraulic or pneumatic equipment shall only be carried out by persons with training, knowledge and experience of hydraulic systems. Pressure lines shall be depressurized before starting any repair work.

General Liability

Liability for machine damage and personal injury is extinguished completely if any unauthorized conversions or modifications are undertaken. The machine must not be modified, enlarged or converted in any way capable of affecting safety without the manufacturer's prior approval.

Starting Machine Movements

Read the Instruction Manual carefully to establish which keys and functions start machine movements.

A Word to the End User

The end user has sole responsibility to enforce the use of safety procedures and guards on the machine. Any other safety devices or procedures due to local regulations should be should be retrofitted in accordance to these regulations and/or the EC Directive on the safety of machines. Operator's position must always be readily accessible. Escape routes must always be kept clear and safety areas should be identified.

Safety Precautions

Safety should be a constant concern for everyone. Always be careful when working with this equipment. While normal safety precautions were taken in the design and manufacture of this equipment, there are some potential safety hazards.

Everyone involved with the operation and maintenance of this equipment should read and follow the instructions in this manual. Operate the equipment only as stated in this manual. Incorrect use could cause damage to the equipment or personal injury.

It is the owner's responsibility to make certain that the operator reads and understands this manual before operating this equipment. It is also the owner's responsibility to make certain that the operator is a qualified and physically able individual, properly trained in the operation of this equipment.

Specific safety warning decals are located on the equipment near the immediate areas of potential hazards. These decals should not be removed or obliterated. Replace them if they become non-readable.

- ALWAYS keep safety shields and covers in place, except for servicing.
- ALWAYS operate equipment in daylight or with adequate working lights.
- Follow daily and weekly checklists, making sure hoses are tightly secured and bolts are tightened.
- ALWAYS watch and avoid holes or deep depressions.

ALWAYS wear adequate eye protection when servicing the hydraulic system and battery.

- NEVER operate a poorly maintained machine.
- NEVER allow persons to operate this machine without proper instruction.
- NEVER put hands or feet under any part of the machine while it is running.
- NEVER attempt to make any adjustments or repairs to the machine while running. Repairs or maintenance should be performed by trained personnel only.
- NEVER work under the machine unless it is safely supported with stands, blocks or a hoist and blocks.
- NEVER touch hot parts of machine.

1. INSTALLATION

NOTE: It is important that the machine technician read this manual and is familiar with all the functions and safety concerns of the unit before Installing and operating.

1.1. Parts and Components

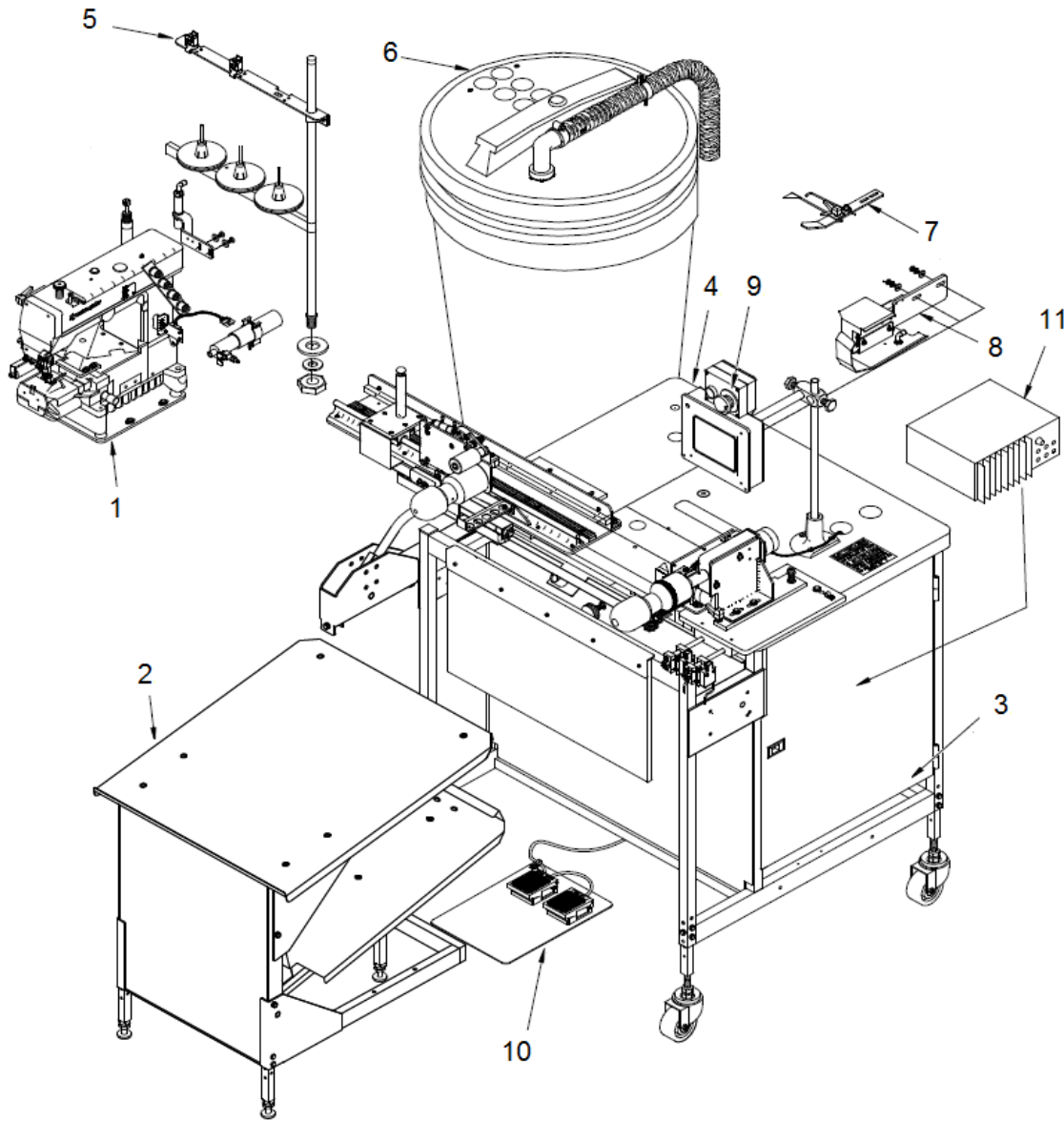

- | | |
|--------------------|--------------------|
| 1.- Sewing Head | 6.- Waste |
| 2.- Stacker | 7.- Guide Tongue |
| 3.- Console | 8.- Guide Plate |
| 4.- Control panel | 9.- Emergency Stop |
| 5.- Thread Sensors | 10.- Foot Pedal |
| | 11.- Stepping Box |

1.2. Technical Data

SPECIFICATIONS / ESPECIFICACIONES	
Voltage (v/ph/hz) / Voltaje (v/ph/hz)	220v 1ph
Current (amps) / Amperaje (amperios)	6.5
Air pressure (psi) / Presión de aire (psi)	90
Air consumption (cfm) / Consumo de aire (cfm)	15
Shipping weight (lbs) / Peso de embarque (lbs)	890
Shipping dimensions (w/l/h, inch) / Dimensiones de embarque (w/l/h, pulgadas)	60 x 54 x 60

1.3. Production

Single Unit: 285 - 300 dozen per 8 hour shift, depending on material and size of parts.

Tandem Setup: Approximately 660 bottom hems per hour, depending on material and size of parts.

1.4. Machine Classes and Codes

For easy reference Atlanta Attachment's Codes are as follow:

112788FY5F

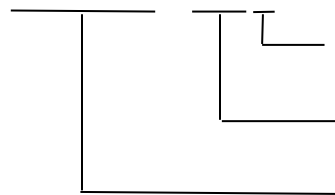

Configuration

Sewing Head

Machine Class

Y1	Yamato 3711 4.5 Ga
Y2	Yamato 3711 6.0 Ga
Y4	Yamato 3711 4.8 Ga (3/16)
Y5	Yamato 3711 5.6 Ga (1/4)
Y6	Yamato 3711 6.4 Ga (1/4)
Y15	Yamato VG3711 5.6 Ga (1/4)
Y7	Yamato 2711 4.8 Ga (3/16)
Y8	Yamato 2711 5.6 Ga (1/4)
Y9	Yamato 2711 6.4 Ga (1/4)
G4	Pegasus W664-35 4.8 Ga (3/16)
G5	Pegasus W664-35 5.6 Ga (1/4)
G6	Pegasus W664-35 6.4 Ga (1/4)
G7	Pegasus W664-08 4.8 Ga (3/16)
G8	Pegasus W664-08 5.6 Ga (1/4)
G9	Pegasus W664-08 6.4 Ga (1/4)

1.5. Options & Classes

8/23/2016





1278-8 CLASSES

2 NEEDLE CIRCULAR BOTTOM HEMMER



Part Number	Description	SEWING HEAD			NEEDLE DISTANCE			LEFT HAND KNIFE		MOTOR		STITCH CONDENSING		NO TOP GUIDE	
		Pegasus	Yamato	Juki	Rimoldi	4.5	4.8	5.6	6.4	W/LHK	N/LHK	PANA	EFGA		W/SC
MOST COMMON															
112788FGSK	2 NDL CIR BOT HMR, PEG/SB 5.6, W/LHK, N/SC, NTG, EFGA	X					X	X	X				X	X	X
112788FG6K	2 NDL CIR BOT HMR, PEG/SB 6.4, W/LHK, N/SC, NTG, EFGA	X					X	X	X				X	X	X
112788FY5K	2 NDL CIR BOT HMR, YAM, SB 5.6MM W/LHK, N/SC, NTG, EFGA		X				X	X	X				X	X	X
112788FY6K	2 NDL CIR BOT HMR, YAM, SB 6.4MM W/LHK, N/SC, NTG, EFGA		X				X	X	X				X	X	X
112788FJ1D	2 NDL CIR BOT HMR, JUKI, SB 6.4MM W/LHK, N/SC, NTG, PANA			X			X	X	X				X	X	X
SPECIAL ORDERS															
112788FG7H	2 NDL CIR BOT HMR, PEG, SB 4.8MM N/LHK, W/SC, NTG, PANA	X				X			X	X					X
112788FG8C	2 NDL CIR BOT HMR, PEG, SB 5.6MM N/LHK, N/SC, PANA	X				X			X	X					X
112788FG8J	2 NDL CIR BOT HMR, PEG/SB 5.6, N/LHK, N/SC, NTG, PANA	X				X			X	X					X
112788FG5F	2 NDL CIR BOT HMR, PEG/SB 5.6, W/LHK, N/SC, NTG, PANA	X				X			X	X					X
112788FG8L	2 NDL CIR BOT HMR, PEG/SB 5.6, W/LHK, N/SC, NTG, EFGA	X				X			X	X					X
112788FG6F	2 NDL CIR BOT HRM, PEG, SB 6.4, W/LHK, N/SC, NTG, PANA	X				X			X	X					X
112788FY4F	2 NDL CIR BOT HMR, YAM, SB 4.8MM W/LHK, N/SC, NTG, PANA		X			X			X	X					X
112788FY4K	2 NDL CIR BOT HMR, YAM, SB 4.8MM W/LHK, N/SC, NTG, EFGA		X			X			X	X					X
112788FY5E	2 NDL CIR BOT HMR, YAM, SB 5.6MM W/LHK, W/SC, NTG, PANA		X			X			X	X					X
112788FY8A	2 NDL CIR BOT HMR, YAM, SB 5.6MM N/LHK, W/SC, EFGA		X			X			X	X					X
112788FY5F	2 NDL CIR BOT HMR, YAM, SB 5.6MM W/LHK, N/SC, NTG, PANA		X			X			X	X					X
112788FY8C	2 NDL CIR BOT HMR, YAM, SB 5.6MM N/LHK, N/SC, PANA		X			X			X	X					X
112788FY8J	2 NDL CIR BOT HMR, YAM/SB 5.6, N/LHK, N/SC, NTG, PANA		X			X			X	X					X
112788FY6E	2 NDL CIR BOT HMR, YAM, SB 6.4MM W/LHK, W/SC, NTG, PANA		X			X			X	X					X
112788FY6F	2 NDL CIR BOT HMR, YAM, SB 6.4MM W/LHK, N/SC, NTG, PANA		X			X			X	X					X
112788FY6K	2 NDL CIR BOT HMR, YAM, SB 6.4MM W/LHK, N/SC, NTG, EFGA		X			X			X	X					X

F : SERIAL BUS
 G : PEGASUS
 Y : YAMATO
 J : JUKI
 R : RIMOLDI
 W/LHK : WITH LEFT HAND KNIFE
 N/LH : NO LEFT HAND KNIFE
 PANA : PANASONIC
 EFGA : EFGA
 W/SC : WITH STITCH CONDENSING
 N/SC : NO STICH CONDENSING
 NTG : NO TOP GUIDE

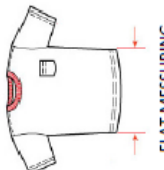
STANDARD	OPTIONS	GARMENT SIZE
BOTTOM COVER  2 NEEDLES  3 NEEDLES	TOP COVER  40-3TCY 40-3TCG  SMALL ROLLERS 1278-8KIT17 REVERSE CURL  1278-8KIT16	 FLAT MEASURING STANDARD 13 - 34 INCHES 33.0 - 86.9 CM OPTIONAL SMALL ROLLERS 10-1/2 - 34 INCHES 26.5 - 86.3 CM

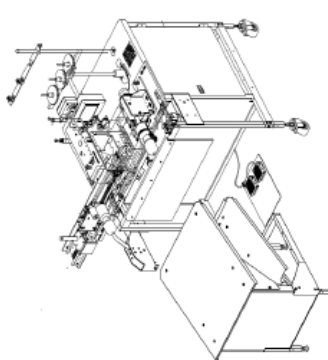

- Features**
- Shirts may be tubular or with side seams.
 - Utilizes single operator for tandem operation
 - Standard hem size 1/2 to 1".
 - Available in 4.8, 5.6, 6.4 gauge.
 - Automatic sizing garments.
 - Minimum fabric trimming waste on knife version
 - Precision tension control
 - 100% cotton thread.
 - Sew various types of material, i.e., fleece, jersey,
 - Stacker accommodates large and small sizes.
 - Reduces ergonomic risk
 - Patented Serial Bus Control System
 - Shirt may be hemmed first or last operation
 - Perfectly aligned oversew
 - Electronic active edge guiding system
- Options**
- Stitich condensing
 - 1278-8KIT17 Kit of small Rollers
 - 1278-8KIT16 Kit Reverse curl, Uncurler
 - 40-3TCY Top Cover Stitch Yamato
 - 40-3TCG Top Cover Stitch Pegasus
- * Recommended**

Installation

1.6. Foot print

Machine foot print is 51"x87". Leave enough free space around to be able to open all doors and have access for maintenance.

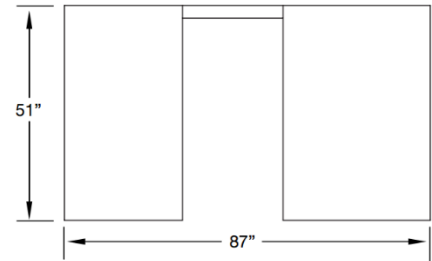

1.7. Machine Identification Label

Machine identification is located on top to the table. Its contents are the machine class and the Serial Number. Ex: 208005081657

Serial number is divide as follow.

First number identify the order number 208005

Next number month of manufacturing (08)

Next number the year of manufacturing (16)

Following a correlative number 57

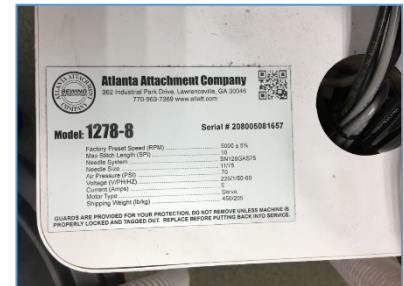

1.8. Installation & Set Up

1. Remove all shipping straps from machine.
2. Inspect the machine for any damage that may have occurred during shipping. If damage is found, report this immediately to your supervisor. Document the damage and provide details and photographs.
3. Position the machine in a desired location on a sound and reasonably level floor. Make sure that there is sufficient lighting over the machine. Remove all packing material.
4. Apply with a clean towel a light coat of oil to all black oxide parts to avoid future corrosion.

1. V-belt

After removing machine from crate, reinstall V-belt on motor and head pulleys

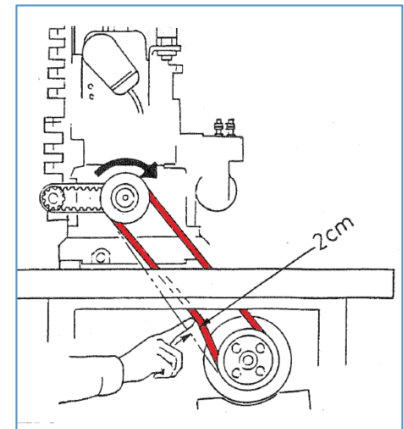

2. Thread Stand

Reinstall thread stand and thread detectors.



3. Computer Boxes

Install Touch Screen. (Serial Bus)



4. Waste System

The waste system comes with left-hand knife machines only. Connect the waste tubes and air connections before operating the machine. Check and clean the foam filter.



5. Stacker

Attach the stacker to the frame. Connect all airlines to the correctly numbered fittings. Manually extend the stacker tray and verify that it is positioned square to the machine and just touches the rubber pad when fully extended. Stackers can be connected left or right according to individual or tandem operation.



6. Sewing Head Lubrication

Oil may be removed before shipping. Prior to using refill and check the oil level in sewing heads. (ISO Viscosity Grade 22 part #)

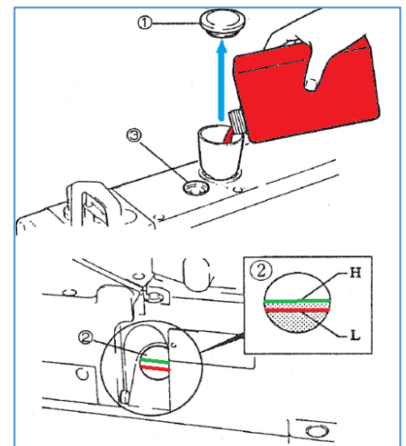

Installation

7. Air Supply

Requires one 3/8" air supply. Set to 90 psi.
Turn the main air lock-out valve (Red Knob before the main pressure regulator) to the "ON" position.
Air consumption is 15 CSM



8. Power Connection

Wire the power cord to 208-230VAC, single phase. 6 Amp.
Turn "ON" the safety switch inside the control box

NOTE: It is essential that the green wire be connected to earth ground.



Video: https://youtu.be/g0na8OUR_PU

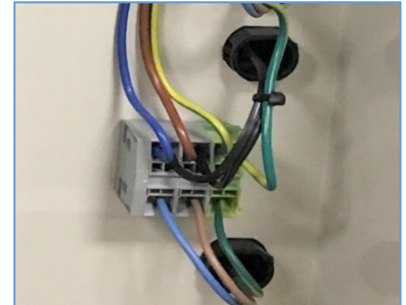

9. Power "ON"

Twist the Emergency Stop Red button "B" to return to its normal position. Turn the machine "ON" by pressing the green button "A" on the box just above the touch screen. The machine touch screen "C" will first display the language choices and after several seconds its show the "MAIN READY" screen. This is the one that the operator will always see upon power up

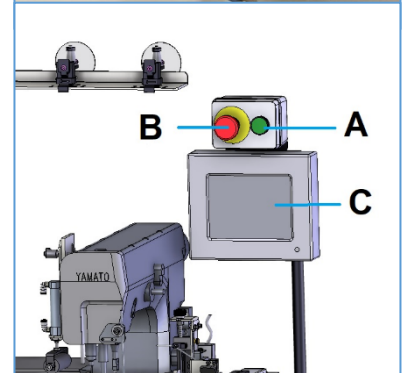

10. Electric Eyes

Turn on power. Examine all electric eyes and ensure they are all adjusted and functioning properly. See service section for instructions



11. Stepping Motors

Press "JOG" buttons and check function of all stepping motors.



12. Footlift Pedal

Step on FOOTLIFT PEDAL (left pedal) and verify proper function of Footlift.



Installation

13. Sewing Head

Rotate hand wheel by hand and check for freedom of movement. Hand wheel rotation should already be set. Test sewing with START SEW pedal on piece of scrap material.



14. Check Folder

Note: Only apply to machines with a top guide
Go to ADVANCED FUNCTIONS, MACHINE DIAGNOSTICS, MANUAL OUTPUT, TEST, and FOLDER TONGUE. Verify folder tongue function and adjustment.



15. Check Guiding & Rollers

Go to Advanced Function, Machine Diagnostics, Manual Output, Test, Next Page, and Guide Cycle. Verify that the guide wheels respond to the correct eyes and the rollers turn in the correct direction. Press RESET.



16. Set up First Garment

- A. Adjust the left roller to fit the garment size. Press the SEMI AUTOMATIC, and load the garment. Check and adjust the body tension air pressure regulator if necessary.
- B. With the garment loaded press, GUIDE CYCLE to jog the garment around the rollers and through the guide wheels. Check and adjust all guiding hardware.
- C. Press PAUSE, CONTINUE to initiate the sewing cycle.



Interim Storage

If the machine needs to be stored temporarily, it must be oiled or greased and kept in a dry, protected place to prevent damage from the weather. A corrosion-inhibiting coating should be applied if the machine has to be stored for an extended period of time, and additional precautions should be taken to avoid corrosion.

2. OPERATION

Note: It is important that the machine operator read this manual and is familiar with all the functions and safety concerns of the unit before operating.

2.1. Individual Components

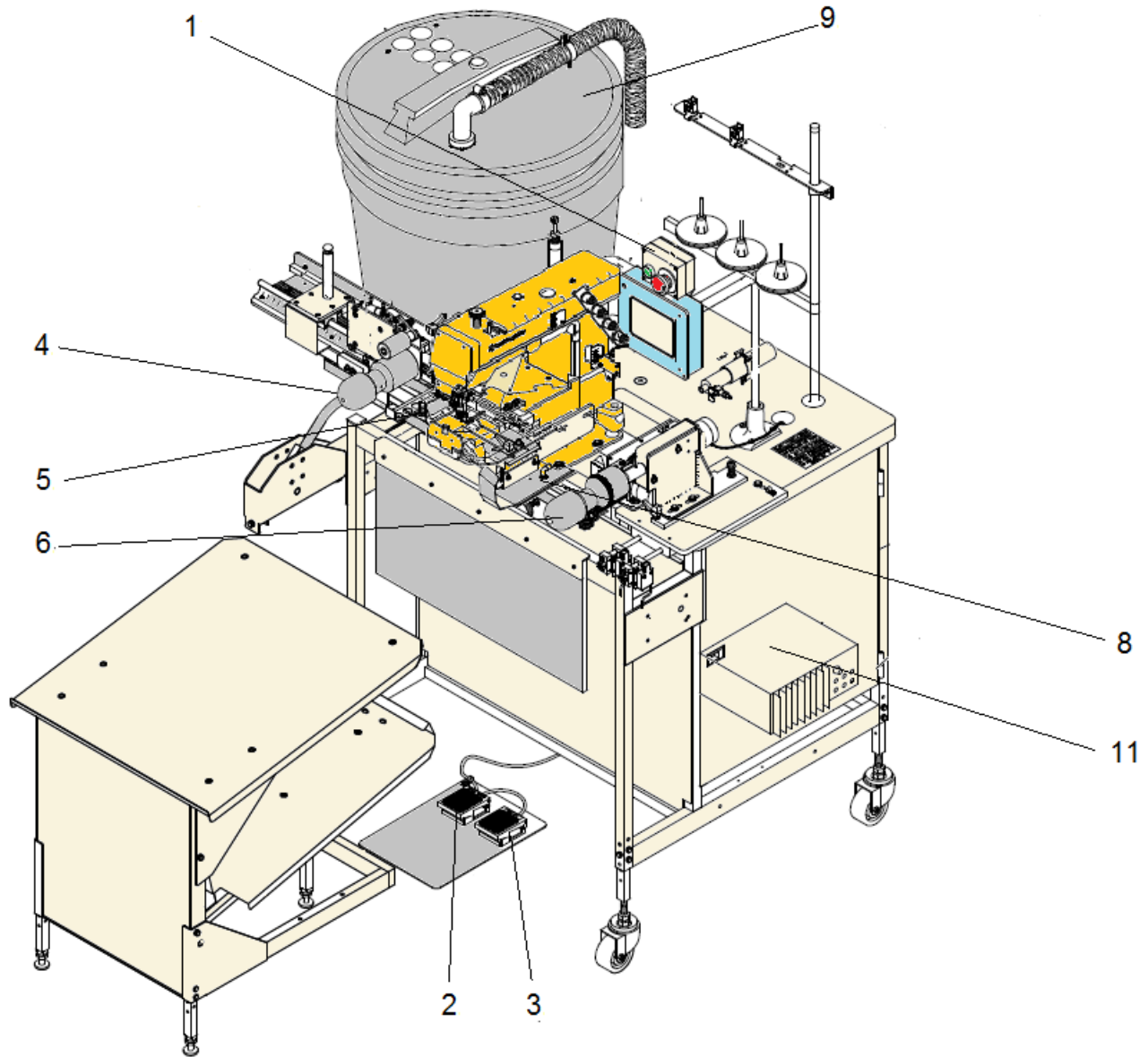

1.- Power On	8.- Lower Guiding
2.- Footlift Pedal	9.- Waste System
3.- Start Sew Pedal	10.- Sewing Motor Control Boxes
4.- Left Roller Assembly	11.- Stepping Motors Control Boxes
5.- Presser Roller	
6.- Right Roller Assembly	

Operation Instructions

2.1.1. Control Panel

The Control Panel allows the operator to start and stop the automatic function of the machine, shut off power to the machine in the event of an emergency.

Caution: Unlocking the button with the Power “ON” engaged will turn on power to the machine.

1. Power On

Power the machine “ON”

2. Emergency Stop

Pressing the red button “B” will turn off power to the machine. This button will lock when pressed. Twisting the button will cause it to unlock and return to its normal position.

3. Serial Bus control

Controls all machine functions “C”. More details are available in related chapters in this manual

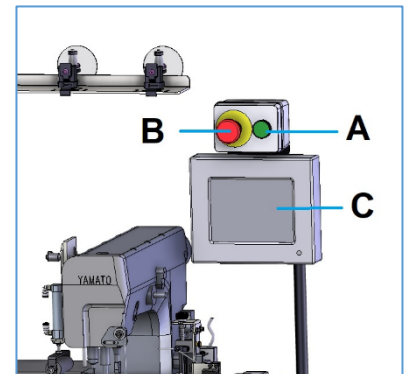

2.1.2. Footlift Pedal

This pedal will raise/lower the presser foot. It Causes under trimming and thread wiping if the head has been sewing, also disables the automatic sewing functions.

2.1.3. Start Sew Pedal

Activating this pedal will run the sewing machine and disable the automatic functions.



2.1.4. Left Roller Assembly

The left roller (B) has a quick release button (A) to allow easy size changes. This controls the tension on the garment while sewing. Automatically adjusts for size variations within a bundle. Takes up any “slack” created in the garment while sewing to ensure uniform hem formation and precise over-sew alignment.

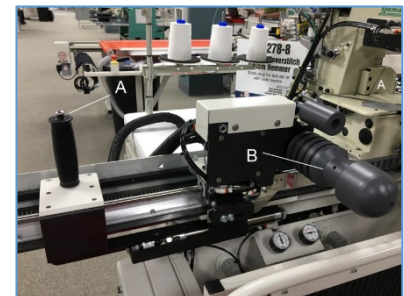

2.1.5. Presser Roller

The Presser roller (C) is located behind the sewing head, it ensures uniform hem formation during the pre-feed jog cycle.



Operation Instructions

2.1.6. Right Roller Assembly

The right roller (D) consist of the right feed roller, upper guiding system and lower guiding system. Swings out for easy access to sewing head for maintenance.

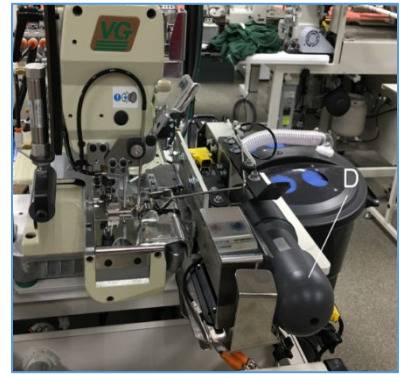

2.1.7. Lower Guiding

Provides the correct amount of fabric for proper hem formation. Controls alignment of garment on the front roller. Has self-diagnostic jam detection to ensure proper guiding performance.

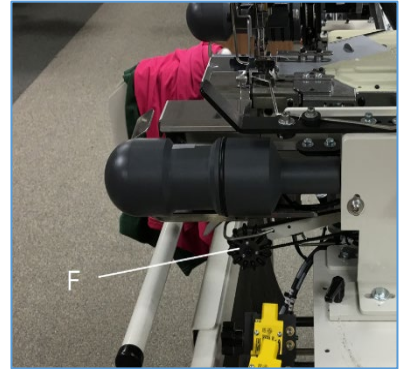

2.1.8. Waste System

Supplied on left hand knife models only. Only runs while sewing to reduce air consumption. Has filtered waste container to trap lint. It needs to be cleaned every day. See maintenance section on this manual

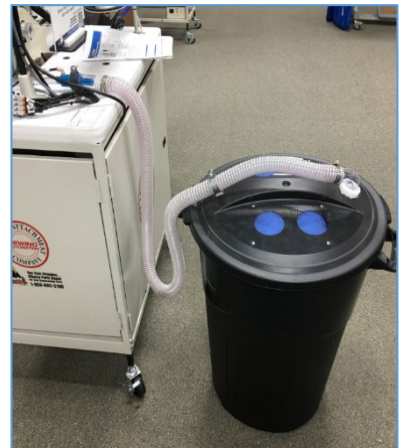

2.1.9. Sewing Motor Control Boxes

Units can be supplied with two different motor types.

1. Efka

It is located inside the right door under the machine. It contains an On/Off switch which should always remain in the “ON” position. This box controls the Sewing head



2. Panasonic

It is located inside the right door under the machine (A). This box controls the sewing head.

2.1.10. Stepping Motors Control Boxes

There is one control box (B) located under the machine. The amber light must be on during machine operation. There is a power switch located at the rear of the box. It drives both rollers and the guide wheel



2.2. Touch-Screen

2.2.1. General Operation

Twist the Emergency Stop Red button “B” to return to its normal position. Turn the machine “ON” by pressing the green button “A” on the box just above the touch screen “C”. The machine will first display the language choices, and after several seconds, it will show the “MAIN READY” screen. This screen is the one that the operator will always see upon power-up up.

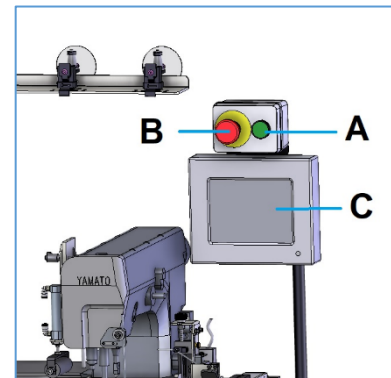

Caution: Do Not Use Any Sharp Objects to Touch the Screen

The graphics images presented on the touch screen show "3-dimensional" buttons, which may be pressed to access other screens, change counters and timers, or actuate hardware. Areas lacking the "3 3-dimensional" border contain information only. The row of buttons across the bottom of the screen is called Standard buttons. They will appear or change based on the needs of the current screen.

RESET: Always brings the machine back to its original power-up state.



LANGUAGE: Return to the language screen. You can select multiple languages to use.

HOME: Leaves the current screen and takes you to an appropriate screen (usually to the main operating screen). Return to the main screen.

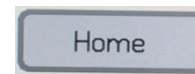

CLOCK: The lower right button allows access to a screen for setting the correct time. While on the Main Screen, it allows you to set the time and date. On all other screens, it is a display only.

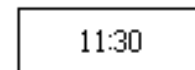

EXIT: Leaves the current screen and takes you to an appropriate screen (usually back one level or to the previous screen you were on).

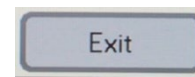

CONTINUE: Used to restart an event or function that has been temporarily paused or suspended.

Others buttons are localized on top of or inside the screen.

ARROWS: Pressing the arrow keys right or left will take you to the next or previous page.



COUNTERS: Are identified with the "+" and "-" buttons in the corners. These counters can be adjusted by pressing the "+" and "-" buttons.

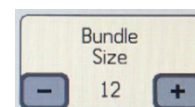

NOTES: When a button has a white background, the function is “ON” or enabled. A dark background indicates off or disabled. Some buttons may toggle ON or OFF, others must be held in the ON state.

Operation Instructions

Other screens display whenever there is a machine error or another condition that prevents the machine from operating. Follow the instructions on the screens to resolve the problem. There are also advanced settings and advanced functions available. These functions are only accessible by a password, and include timers that control machine hardware, input and output test screens, and machine statistics. To get to the advanced functions, the appropriate password must be entered at the security screen. Security access is reset whenever the main power is turned off, or the RESET button on the main page is pressed.

2.2.2. Available Menus 1278-8-G

The following is a summary of the different screens and their functions available for the Sewing Operator.

Video: <https://youtu.be/rL4Zt64eszA>

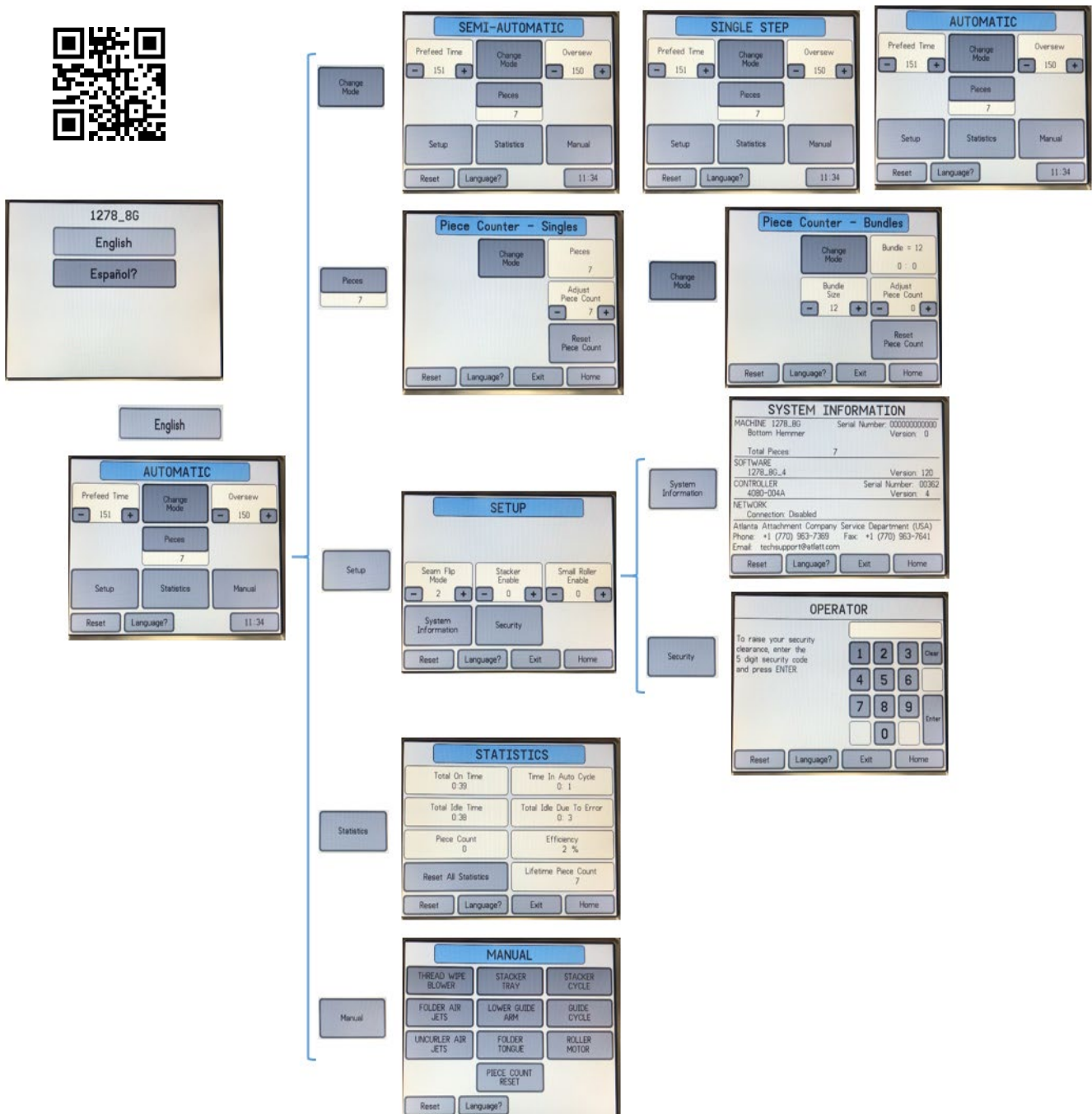

Operation Instructions

1. AUTOMATIC

It is the main screen. The machine will run after loading the material.

A. PREFEED TIME

Allows the user to control the amount of time the rollers jog before sewing begins. It is used to position the hem beginning on the garment. See seam adjustment for details. This option is only available when you have the Seam mode flip "0" activated

B. OVERSEW

This setting allows the user to control the length of over-sew stitches at the end of the seam. This option is only available when you have the Seam mode flip "0" activated

C. CHANGE MODE

Allow to change from Automatic to Semi-Automatic or Single Step mode

D. SEMI-AUTOMATIC

Pressing this button places the machine in Semi-Automatic Mode. In this Mode, the operator loads the garment and the left roller expands to the correct tension, jogs to the start position and the machine pauses. To complete the cycle, the operator must press the continue button on the touch screen.

E. SINGLE STEP

Pressing this button places the machine in Single Step Mode. In Single Step Mode, the operator loads the garment, and the left roller expands to the correct tension and the machine pauses. To continue to the next Single Step pause point, the operator must press the continue button on the touch screen. In the Single Step Mode, the machine will pause at every major change point in the cycle to allow the mechanic to trouble shoot the machine.

Pause Points for Single Step Mode

1. The first pause point is when the shirt is tensioned after loading.
2. The second pause point is just before the machine begins sewing.
3. The third pause point is when the start of sewing is detected on the bottom. (Eye #1 stays uncovered for the amount of time in setting #7)
4. The fourth pause point is when the start of sewing is detected on top. (Eye #4 becomes uncovered for the amount of time in setting #8).
5. The fifth pause point is just before the wiper arm fires.

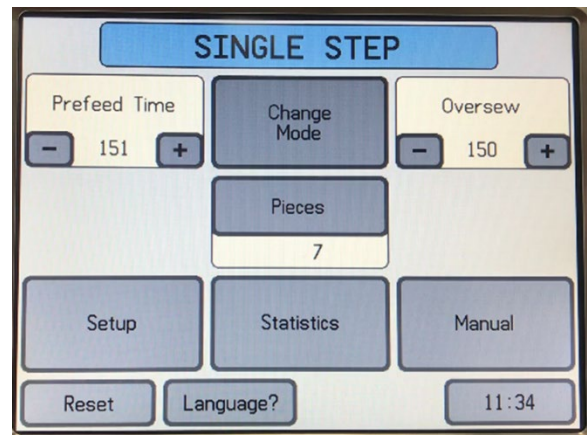
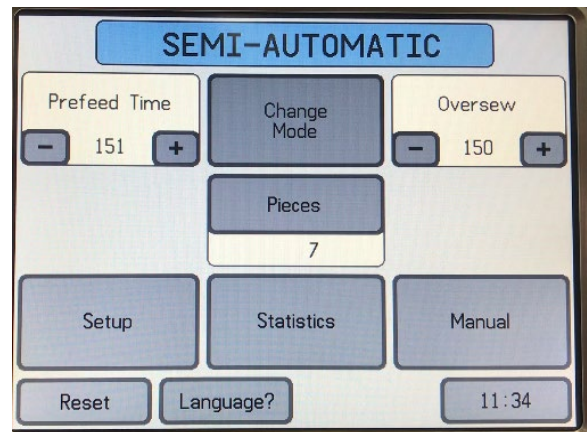
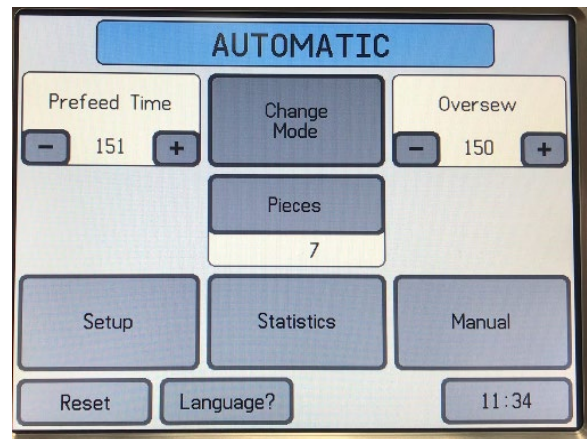

Operation Instructions

F. PIECES

Show the amount of piece/bundles that has been made since the last count reset.

Pressing this button give you access to the counting Screens

1. PIECE COUNTER SINGLES

This is an adjustable piece counter that an increment every time the stacker operates in automatic mode.

2. PIECE COUNTER BUNDLES

This is an adjustable counter that an increment every time the count reach a preset bundle size.

G. SET UP

From this screen the Seam mode can be changed, Stacker been activated same as the optional small rollers. Give access to the System Information and Security screens

3. SYSTEM INFORMATION

Show combine Data and Program module from the memory module.

Serial number is store on the memory module and software with controller on the program module.

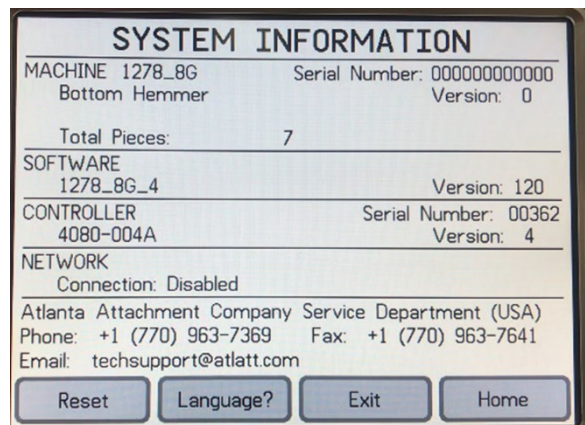
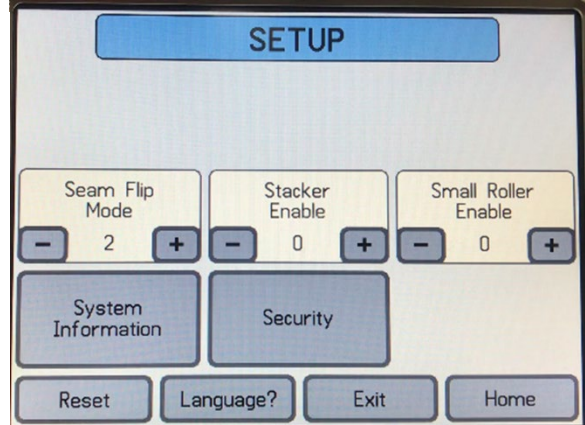
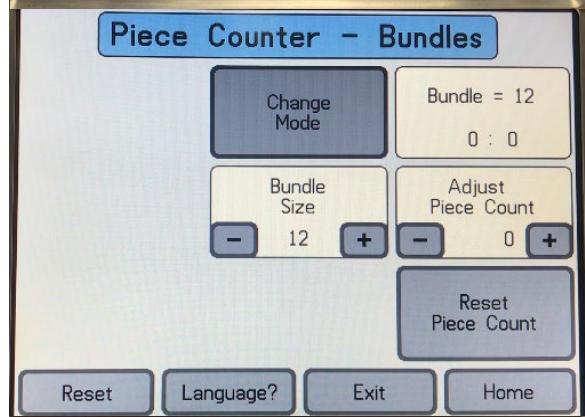
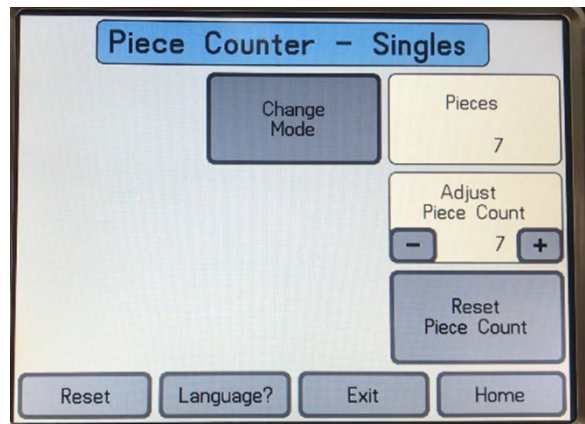

Operation Instructions

4. SECURITY

These functions are only accessible by a password, and include: timers that control machine hardware, input and output test screens, and machine statistics. To get to the advanced functions the appropriate password must be entered at the security screen. Security access is reset whenever the main power is turned off, or the RESET button on the main page is pressed.

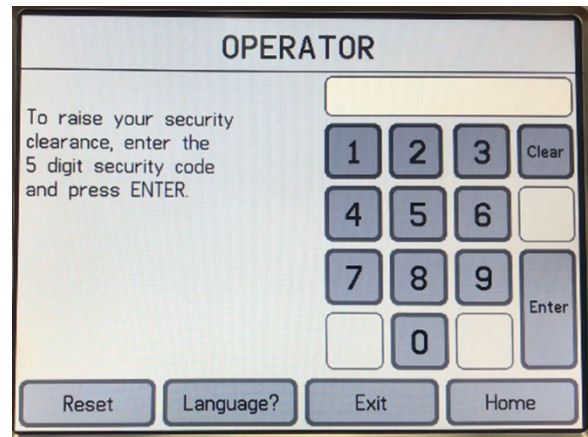

H. STATISTIC

This button takes you to the Statistics screen which displays statistical information on the operation of the machine. The statistics page is set up to give the supervisor a rough estimate of the machine usage. Resetting the statistics requires a supervisor security level.

- Total On Time is how long the machine has been powered up since the last reset.
- Time In Auto Cycle is how long the machine has run in the automatic mode since the last reset.
- Total Idle Time is how long the machine has been powered up, but the machine has not been running since the last reset.
- Total Idle Time Due To Error is the amount of time the machine has been powered up, but not running due to an error registered by the serial bus system, since the last reset.
- Piece Count is the number of cycles the machine has run since the last reset.
- Efficiency is Time In Auto Cycle divided by Total On Time.
- Lifetime Piece Count is the total number of cycles the machine has run. It is not reset by pressing the Reset All Statistics button.

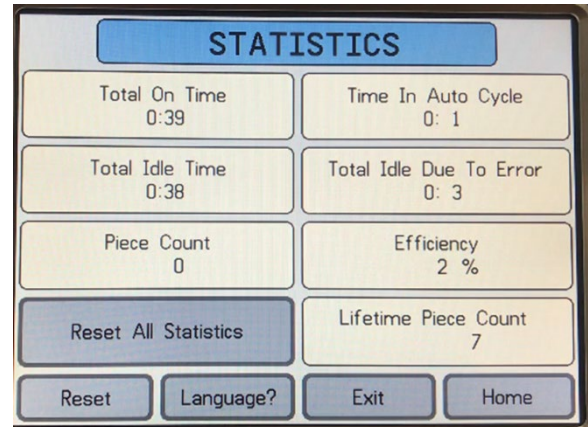

I. MANUAL

Operator will be able to activate some machine functions. To RESUME normal operation reset needs to be pressed

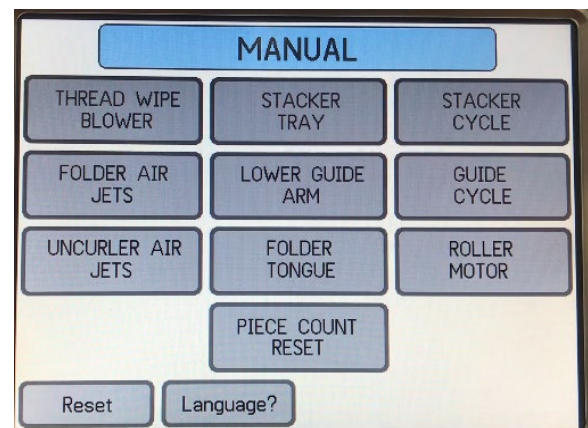

2.3. Threading

Thread the machine following the sewing head manufacturer's instructions

2.3.1. Thread Break Detectors.

1. Lopper Thread Sensor

This type of thread detector monitors the consistent movement of thread at a 5° angle (see picture) over a ceramic surface. With the unit running in manual mode, the three LED's on the detectors must not be on. The presence of a red light on any of the detectors indicates thread breakage or mis adjustment, thus causing the unit to stop.

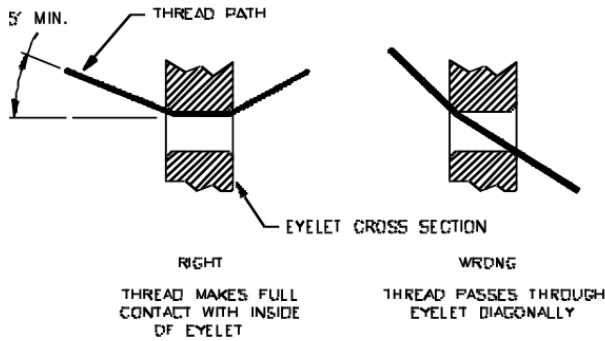
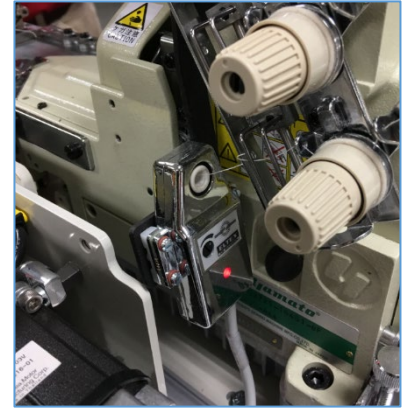

CROSS SECTION OF THREAD EYELET SHOWING RIGHT AND WRONG THREAD PATH.

2. Needle Thread Sensor

Part Number: (4003-3WT2)

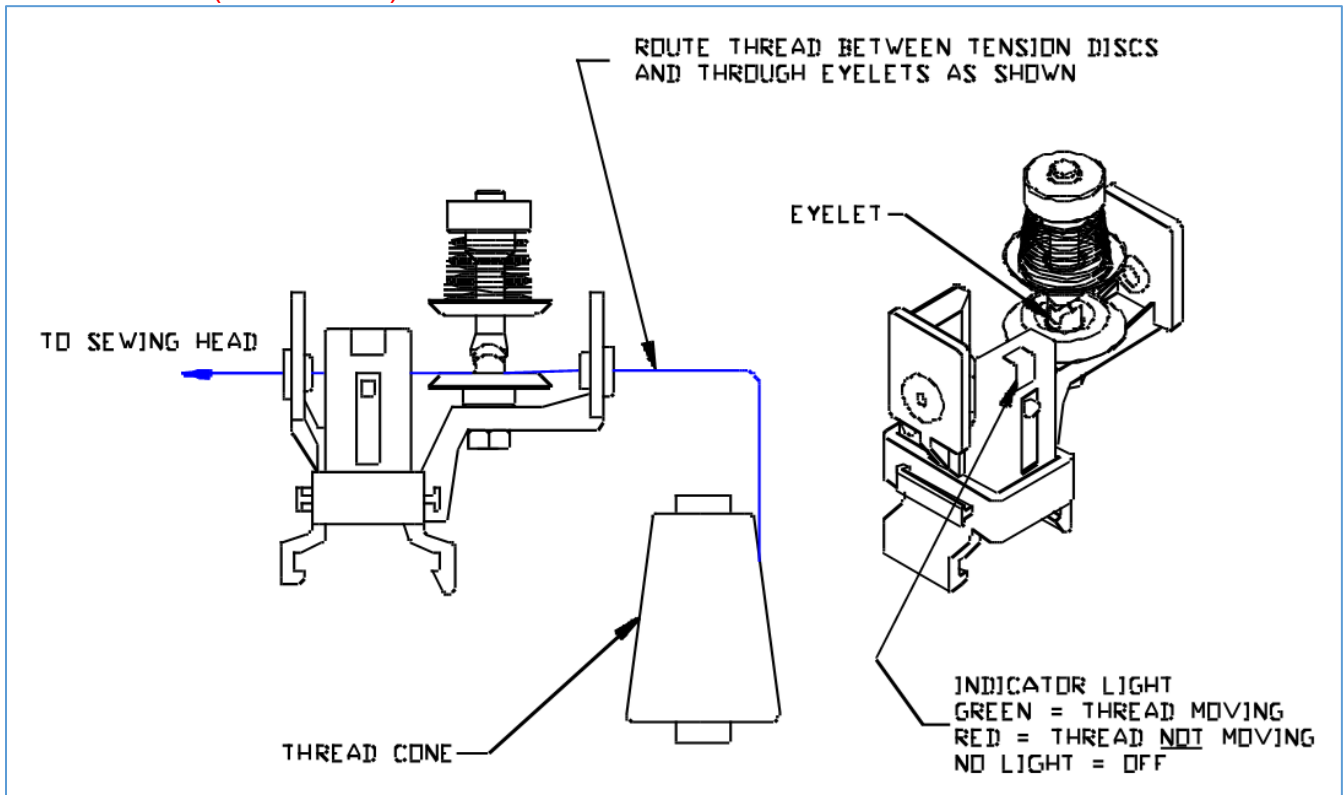

2.4. Sewing

This unit incorporates a two-needle cover stitch sewing head with a left-hand knife with electro-pneumatic expansion rollers for size control, a state-of-the-art edge guiding system, a fabric folding system, and an automatic stacker.

2.4.1. Sequence

Stage 1 Loading

- The operator takes a garment from the bundle located on top of the stacker table.

Video: https://youtu.be/Klhx_t2t4ng



- The garment is loaded onto the rollers until the right electric eye is fully covered.



Stage 2 Jogging

- The left roller automatically expands until the tension switch is activated.
- The pre-feed jog cycle begins and runs for the duration set in Setting #2 (Pre-feed Jog Time).
- During this cycle, the lower (body) guide directs the fabric using the right electric eye, which monitors the raw edge of the garment, while all air jets are activated.
- When the jog cycle finishes, the machine transitions into the automatic sewing cycle.



Stage 3 Seam Start

- At the start of this stage, the sewing machine continues sewing, the fabric's raw edge continues to be guided by the lower wheel guide using the right electric eye.
- When the sewn seam is detected by this eye, control shifts to the left electric eye and the wheel, which guides the clean edge.
- Sewing continues under this control until upper electric eye #4 (the seam detect eye) is uncovered, triggering the next stage.



Stage 4 Seam End

- The fabric continues to be guided by the left electric eye.
- Sewing proceeds until Setting #11 (Over-sew Length Adjustment) is reached.
- If the unit is equipped with a side seam detector, once the side seam is detected, the machine continues sewing for a programmable stitch count before stopping.



Stage 5 Stacking

- The cycle ends with stitch condensing (if enabled), thread trimming, and stacking.

2.5. Size Adjustments

2.5.1. Left roller

To change shirt sizes, the left roller assembly is adjusted to fit the shirt.

The operator pulls up on the handle on the roller assembly to move it to the position needed.

Video: <https://youtu.be/b3RQmJKGhV0>

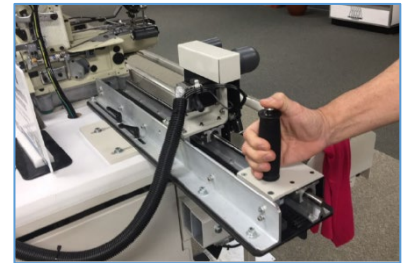

If larger sizes need to be sewn, the left roller base can be moved out by loosening the handle screws, sliding it out to the left, and retightening the handle screws.

Sizes up to 4XL can be sewn, depending on the weight of the shirt.



The correct position allows the shirt to be loaded without stretching the shirt over the rollers.



2.5.2. Pre-feed time

The pre-feed time may need to be changed accordingly to the seam start point reference. Change the Pre-Feed time at the AUTOMATIC Main Screen.

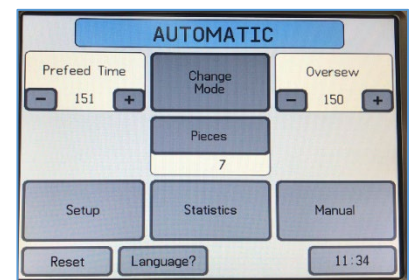

2.6. Maintenance

It is important that the machine operator read this manual and is familiar with all the functions and safety concerns of the unit before operating.

2.6.1. General Safety Instructions

Maintenance should only be performed by trained, qualified personnel. Before performing any maintenance or repair work, switch off the electrical, pneumatic, etc., power to the machine at the primary source and secure it with a padlock so that it cannot be switched on again without authorization. Refer to lockout/tag out procedures

- Always wear proper safety equipment when operating or performing maintenance on any equipment.
- All recommended maintenance is for a single shift schedule; adjust as necessary for a multi-shift operation.
- Equipment should not be used for purposes other than designed or specified.
- The machine shall be switched off, come to a standstill, and be secured so that it cannot be switched on again inadvertently before starting any maintenance work whatsoever.
- Use proper lockout/tag out procedures to secure the machine against inadvertent startup.
- Remove any oil, grease, dirt, and waste from the machine, particularly from the connections and screws, when starting the maintenance and/or repair work.
- Do not use any corrosive-cleaning agents.
- Use lint-free rags.
- Retighten all screw connections that have to be loosened for the maintenance and repair work.
- Any safety mechanisms that have to be dismantled for setting up, maintenance or repair purposes must be refitted and checked immediately after completing the work

2.6.2. Preparation

Move the front guide and the front Roller



Open all sewing head covers





Preventive Maintenance 8 Hrs

Model: 12788	Required Materials Oilcan Oil for sewing machine Clean cloth Compressed air
Serial #:	
Operation: Bottom Hemming	
Sew Head:	
Needle: SNUY128GAS-12 80	

Before starting the day's shift with "The Machine Off"

.- Wipe with a clean cloth lents of all electric eyes and reflecting tapes

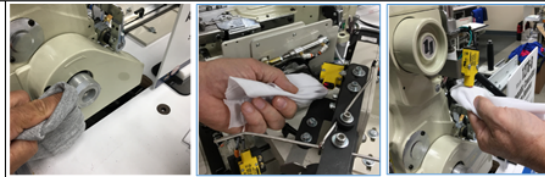

.- Check for liquid waste in the air filter and drain if necessary.



.- Check the oil level in the lubrication tank and add if required. Keep Level between lines H and L of oil gauge

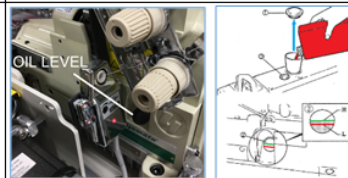

Clean filter on waist container. Dump as necessary

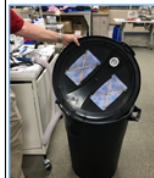

After a day's shift with "The Machine Off"

.- Check for thread accumulation on rollers, pulleys and the moving parts

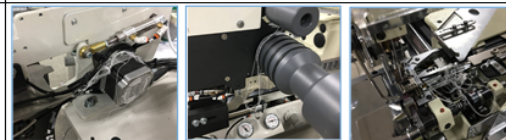

.- Open covers, blow out and wipe with a clean cloth the machine and remove any dirt or tangled threads. Clean sewing motor ventilation

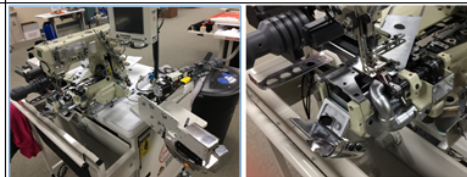

.- Cover the machine and notify the supervisor of any unusual noise or abnormality that is present during the working shift



3. SERVICE

NOTE: Maintenance should only be performed by trained, qualified personnel.

3.1. Lockout/Tagout Program

"Lockout/Tagout (LOTO)" refers to specific practices and procedures to safeguard employees from the unexpected energization or startup of machinery and equipment, or the release of hazardous energy during service or maintenance activities. This requires that a designated individual turn off and disconnect the machinery or equipment from its energy source(s) before performing service or maintenance, and that the authorized employee(s) either lock or tag the energy-isolating device(s) to prevent the release of hazardous energy and take steps to verify that the energy has been isolated effectively.

Equipment Energy Control Procedure Lockout/Tagout Program				
Description:		Bottom Hemmer	Model:	12788
Manufacturer:		Atlanta Attachment Co.	Location:	
Energy		Location	Magnitude	Control Method
Electrical:	X	Disconnect/Ctrl Box	220V	Lockout & Tag
Pneumatic:	X	Main Regulator	90 PSI	Lockout & Tag
Gravity:	X	Rollers		
Remember to Release All Stored Energy!				
Shutdown Procedure:				
Inform all affected personnel that the machine will be in Lockout status. Turn the power and pneumatic disconnects to the OFF position. Fill out the tag with the necessary information about the Lockout. Install the Lockout device. Verify that all stored electrical energy has been released by pressing the power on button. Also, use a meter to test circuits in the electrical panel to ensure stored energy is released there as well. Perform necessary maintenance, services and/or repairs.				
Startup Procedure:				
Inform all affected personnel that the Lockout of this machine is being removed. Replace any guards or safety devices that may have been removed during maintenance. Remove the Lockout device and tag. Turn the power and pneumatic disconnects to the ON position. Push the green button on the back of the control panel to turn the machine on. Inform all affected personnel that the Lockout has been removed and that the machine is ready for normal production operation.				

Approved By: _____

Date: _____

3.2. Mechanical

NOTE: Qualified service technicians should perform all maintenance.

3.2.1. Assemblies Alignment

The sewing head, left roller, and right roller must all be squared with the tabletop.

- **Sewing Head:** Make sure the distance is equal on both sides and that both adjustment screws are centered.

Video: <https://youtu.be/Fb3d4v4FW3M>

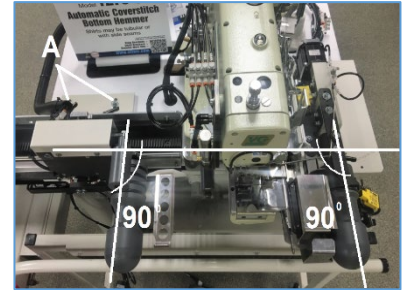

- **Left Roller:** It should be set diagonally to the main table. The position is adjusted through the two screws on the roller plate “A”. Measurements can be taken to confirm proper alignment.
- **Right Roller:** It also needs to be set diagonally to the table, with both adjustment screws. The right-hand roller position is set by the stop block screwed into the tabletop “B”

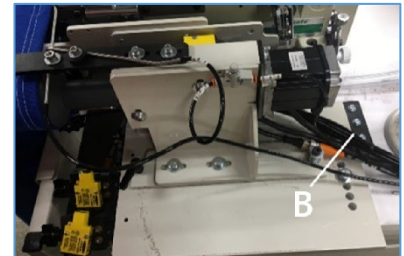

1. Left Roller

The edge of the hemming should be set under the pinch roller at $\frac{1}{2}$ to $\frac{3}{4}$ of the total width of the hem. **(B)** For example, if the hem is 1 inch wide, the distance from the edge of the roller to the hem should be about $\frac{1}{2}$ inch

The left roller position is set using the base plate with slots mounted on the tabletop. **(A)**

Video: <https://youtu.be/BwPFLVWFJ3g>

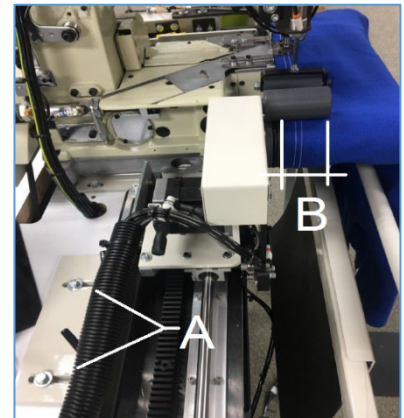

1. Right-Hand Roller

- **Alignment:** Requires the upper edge of the waterfall to be set $\frac{1}{8}$ inch to the right of the sewing guide. Remember to keep it diagonal to the machine table.

Note: Large O-rings located on the guide rollers should be replaced on average every 6 months or more frequently if they become hard and slick.

They will naturally harden due to climate, heat, and dust. The softness and sticky surface of the new O-rings have a greater ability to hold the shirt from falling off the rollers with less air pressure used to extend the left roller.

Video: <https://youtu.be/7ayhbs3Y6vM>

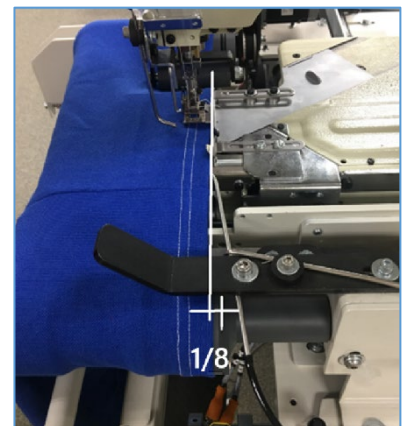

- **Height:** Must be adjusted so that it is aligned with the upper plate and set 1/8 inch below the sewing machine throat plate. Both the roller and the plate have independent adjustment screws, allowing precise alignment. This adjustment helps keep the material flat and guided adequately before it reaches the presser foot.

Video: https://youtu.be/UmFa-x6cR_A

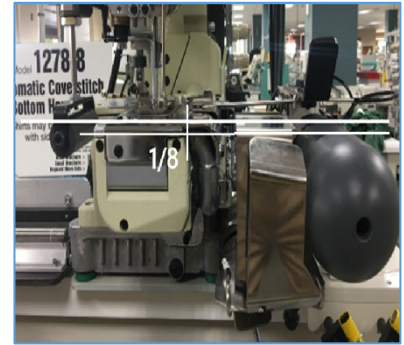

2. Tension Roller

The Tension Roller (**B**) must be parallel and aligned with the sewing head, with the bracket (**A**) set at its maximum height. Its function is to keep the folded edge controlled and ensure the material remains flat against the sewing machine plate.

Video: <https://youtu.be/-Zpp6QeFuyY>

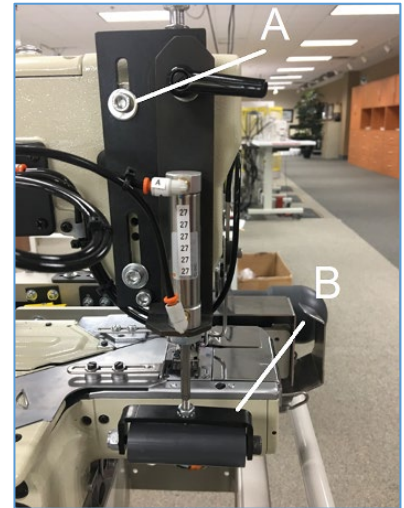

3.2.2. Presser Foot Height

The presser foot has three positions, controlled by two cylinders.

Upper position: Used when loading the material. Controlled by the right-hand cylinder. The maximum height should not exceed the edge guide. Adjustments are made with the limit screw “**A**”

Middle position: Half-stroke down, used when jogging or positioning the material before sewing. Controlled by the left cylinder. Adjustments are made with the limit screw “**B**”

Lower position: Fully down against the throat plate, required during sewing.

Video: <https://youtu.be/gH-3QCJgEto>

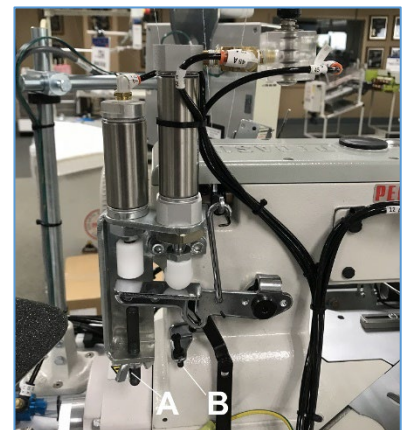

3.2.3. Seam

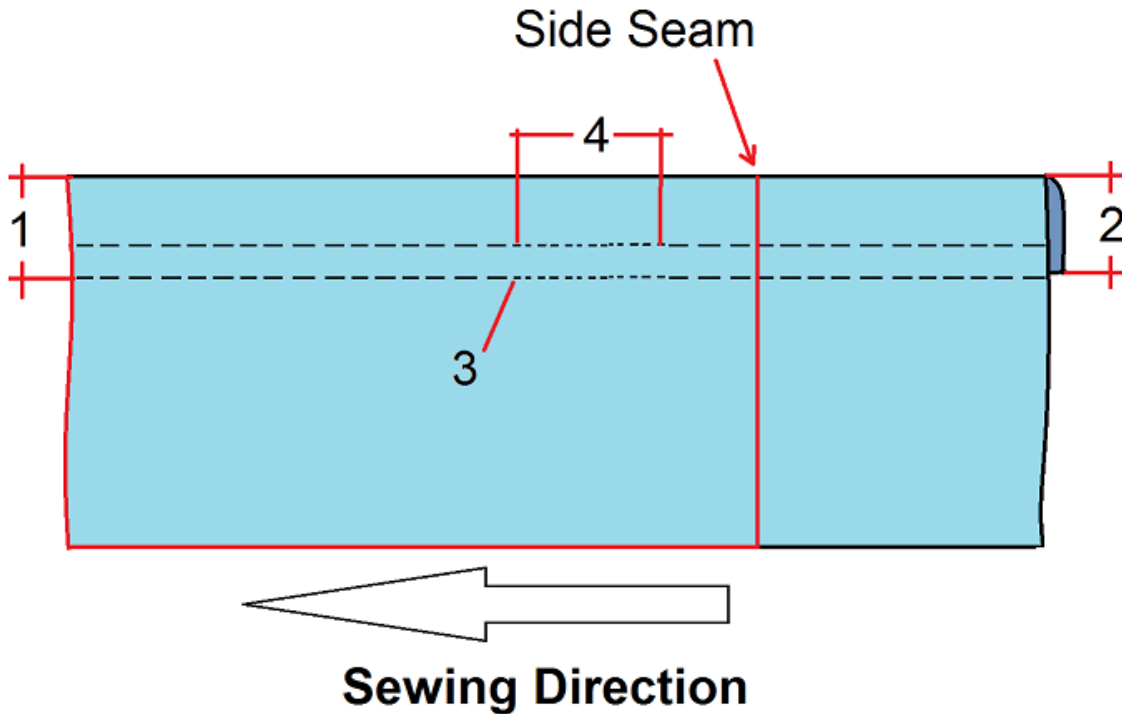

1. Seam Margin

The seam margin is the distance from the left needle to the folded edge of the material. If it is larger than the distance from the left needle to the right edge of the foot, an extension plate cut to the size necessary must be added to the foot. The sewing head edge guide is aligned with the edge of the presser foot plate.

2. Cutting Margin

The knife position in relation to the needles determines the cutting margin. If the knife is set to its right-most position against the throat plate, the raw edge of the material will be covered by the cover stitch. If the knife is set aligned with the left needle, then the raw edge will be in line with the left needle stitch line. If the knife is aligned to the left side of the left needle, then the raw edge will be outside of the cover stitch.

3. Seams With flip mode disabled

A. Seam Beginning

The seam beginning is set by the Pre-feed Time on the screen. The shirt is usually loaded front side up, and the Pre-feed Time is set so that the hem starts just before the left side seam. If it is preferred, the start of the hem can begin at the side seam. There is a variance in the start position because of variances in the shirt size and the amount of stretch in each shirt.

B. Seam Over-sew

The seam over-sew is set by the Over-sew setting on the screen. When the hem beginning uncovers eye # 4 behind the right roller, the over-sew count begins. It is counting stitches. The higher the number set in the counter, the longer the over-sew will be.

4. Seams with Flip Mode Available

A. Seam Beginning

Determine the beginning of the seam in reference to the side seam. (blue line)

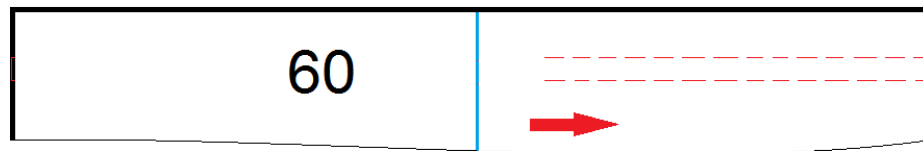
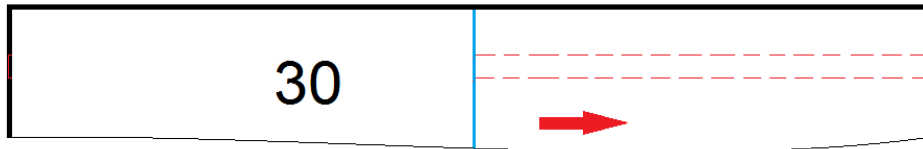
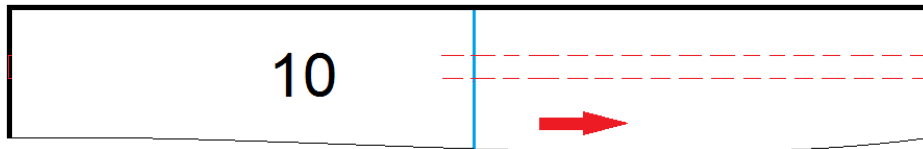

B. Seam End

A. Determine the end of the seam in reference to the side seam. (blue line)

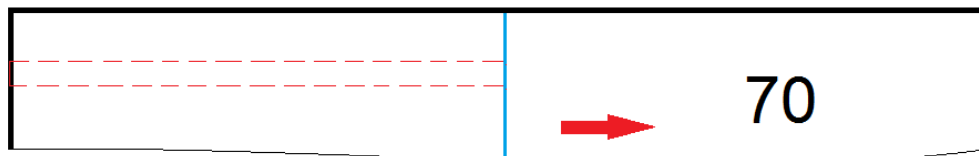

3.2.4. Adjustments

1. Changing Seam Margin

To change the seam margin,

- Install a different extension plate on the presser foot or replace the foot with one that has the correct size plate.
- Adjust the edge guide on the sewing head to match the new foot (see Right Roller Adjustments).

Video: <https://youtu.be/UegfRzRaSio>

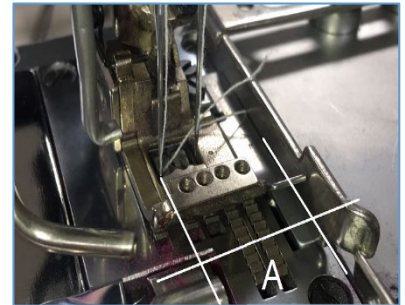

- Realign the right-hand roller assembly to the repositioned edge guide.
- Loosen the two 1/4-20 bolts that secure the assembly to the pivot plate.
- Adjust the roller assembly until it is aligned with the edge guide.

Video: <https://youtu.be/7ayhbs3Y6vM>

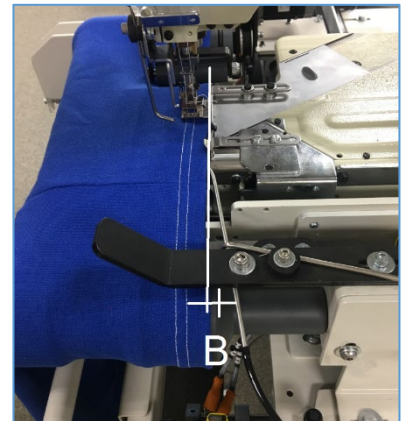

- Adjust edge guide eyes #1 and #2 to the new position.

Video: <https://youtu.be/WNbgafG1r-E>

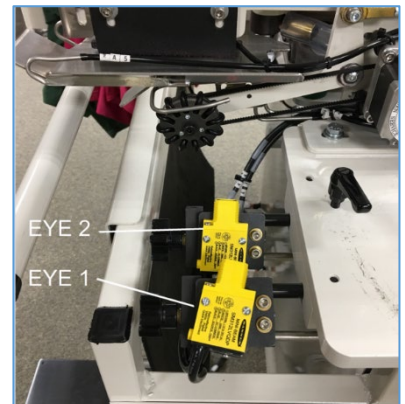

- Check the folder flag “A” for alignment. Reposition it if necessary to avoid interference with the sewing head edge guide and to maintain proper alignment with the knife.

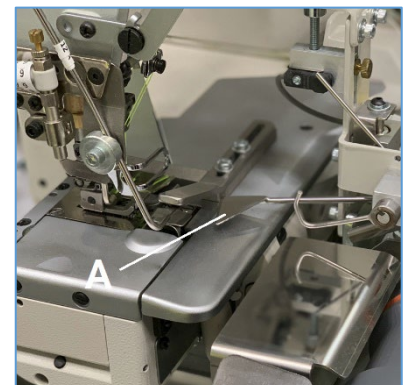

Service Instructions

2. Changing Stitch Length

To adjust the stitch length on the 1278-8, follow these steps

- A. Set the stitch length on the sewing head using the adjustment knob on the front of the head.
- B. Run a seam manually without the rollers until you get the stitch length required



- C. Load a sample shirt and sew the hem, incorporating the rollers



- D. Watch the material as it sews.
 - If the material tries to pull out from under the foot as it sews, the rollers' speed is too fast.
 - If the material is loose between the foot and the pressure roller behind the foot, the rollers' speed is too slow.



For a stitch length of 11 stitches per inch (SPI), the driver box should be set to around 35-39 to start.

- If the stitch length is changed, the roller speed must be changed.
- If the stitch length is made longer, the roller speed will need to be increased.
- If the stitch length is shortened, the roller speed will need to be decreased
-

Three types of needle plates that provide better Stitches.

Differing in shape, three types of needle plates can be selected according to the material or stitch length. (Common to W500/W600/W700)

- A. Thin fabric with short stitch.
- B. Standard type
- C. Thick material with long stitch.

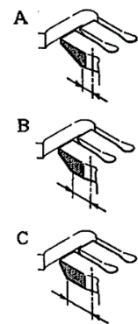

1278-8 Circular Hemmer



Lineal feed Sewing Head (Millimeter per minute)

Stitch per inches (A)	10.00	11.00	12.00	13.00	14.00	
Stitch length mm	2.54	2.31	2.12	1.95	1.81	
RPM Head (B)	4,000	10,160	9,236	8,467	7,815	7,257
	4,250	10,795	9,814	8,996	8,304	7,711
	4,500	11,430	10,391	9,525	8,792	8,164
	4,750	12,065	10,968	10,054	9,281	8,618
	5,000	12,700	11,545	10,583	9,769	9,071
	5,250	13,335	12,123	11,113	10,258	9,525
	5,500	13,970	12,700	11,642	10,746	9,979
	5,750	14,605	13,277	12,171	11,235	10,432
6,000	15,240	13,855	12,700	11,723	10,886	

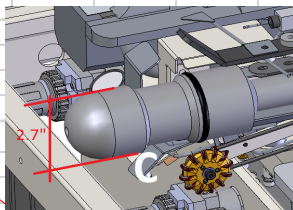
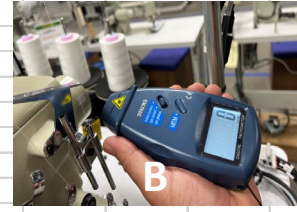
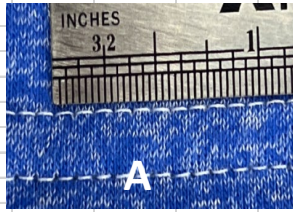

Lineal Feed Roller (Millimeter per Minute)

Diameter Inches (C)	2.70	Perimeter mm	215.45
Diameter mm	68.58		

RPM (D)	30	31	32	33	34	35	36	37	38	39	40	41	42	43	44
mm/min	6,464	6,679	6,894	7,110	7,325	7,541	7,756	7,972	8,187	8,403	8,618	8,833	9,049	9,264	9,480
RPM (D)	45	46	47	48	49	50	51	52	53	54	55	56	57	58	59
mm/min	9,695	9,911	10,126	10,342	10,557	10,773	10,988	11,203	11,419	11,634	11,850	12,065	12,281	12,496	12,712
RPM (D)	60	61	62	63	64	65	66	67	68	69	70	71	72	73	74
mm/min	12,927	13,142	13,358	13,573	13,789	14,004	14,220	14,435	14,651	14,866	15,082	15,297	15,512	15,728	15,943
RPM (D)	75	76	77	78	79	80	81	82	83	84	85	86	87	88	89
mm/min	16,159	16,374	16,590	16,805	17,021	17,236	17,451	17,667	17,882	18,098	18,313	18,529	18,744	18,960	19,175

AP28 Box (E)

Dial (E)	20	21	22	23	24	25	26	27	28	29
RPM	29	30.45	31.9	33.35	34.8	36.25	37.7	39.15	40.6	42.05
Dial (E)	30	31	32	33	34	35	36	37	38	39
RPM	43.5	44.95	46.4	47.85	49.3	50.75	52.2	53.65	55.1	56.55
Dial (E)	40	41	42	43	44	45	46	47	48	49
RPM	58	59.45	60.9	62.35	63.8	65.25	66.7	68.15	69.6	71.05
Dial (E)	50	51	52	53	54	55	56	57	58	59
RPM	72.5	73.95	75.4	76.85	78.3	79.75	81.2	82.65	84.1	85.55



Service Instructions

3.2.5. Folder Flag

If the roller crest is lined up inside the right edge of the foot, the hemmed edge may not uncover eye # 4 when it comes over the top of the roller. The hem beginning won't be detected, and the hem will continue to roll over.

If the roller crest is lined up outside the right edge of the foot, the flag may have difficulty getting the raw edge flat before it goes through the knife and under the foot. The hem quality will be poor.

When the hem beginning comes over the top of the roller, the hem edge should be left of the roller crest on the flat part of the roller.

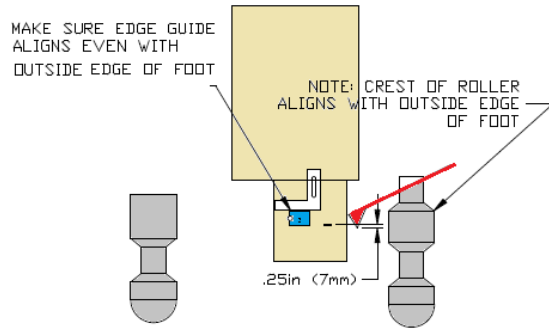

TOP VIEW

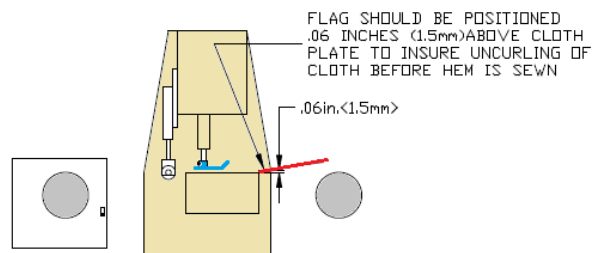

FRONT VIEW

3.2.6. Electric Eyes

The machine is equipped with two electronic eyes that control the garment throughout the jogging and sewing process.

- When the operator loads the material and covers the Eye 1, the jogging process starts. Eye 1 controls the raw edge, sending signals to the guide wheel to keep it aligned with his position.
- After jogging, the machine starts sewing, and Eye #1 keeps looking at the raw edge. During normal operation, EYE #1 alternates between covered and uncovered every 2–3 stitches. The wheel moves left and right to keep control of the raw edge
- When the beginning of a seam passes the lower guide, EYE #1 cannot switch states within the time defined by Setting #7, and the seam is detected (see Advanced Settings 1).
- After the folded seam is detected, the EYE#2 guides the folded Edge of the hem until the seam ends.

Note: In Setting #6, if EYE #1 does not change states within the time defined by Setting #22, jam detection will stop the machine, and the screen will display a lower guiding failure (see Advanced Settings 3)

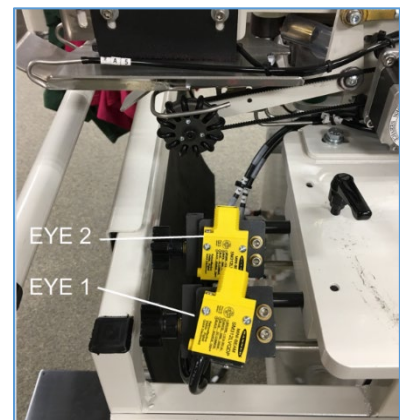

Video: <https://youtu.be/WNbgafG1r-E>

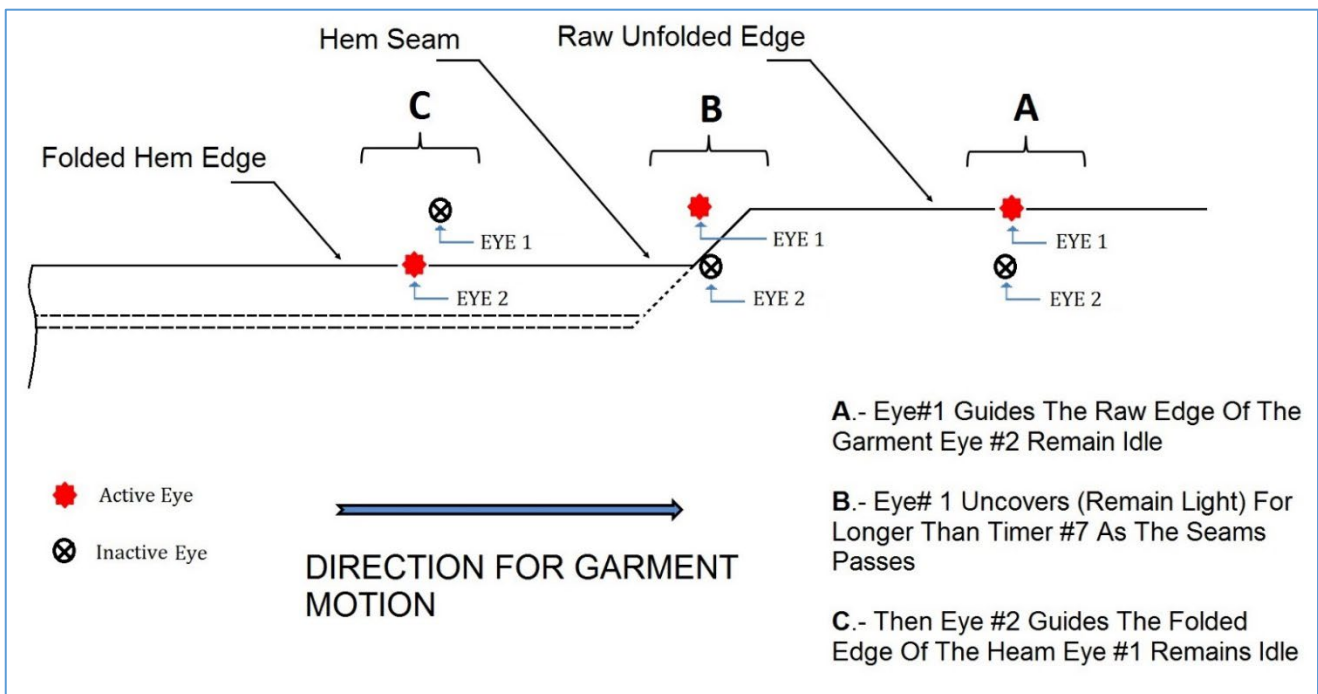

3.3. Pneumatic

NOTE: All maintenance should be performed by a qualified service technician.

3.3.1. Air Maintenance Unit FR

The FR (Filter Regulator). unit assembly is located behind the table. It have3 components the Pressure Relief Valve **(A)** , the Pressure Regulator **(B)** and the Air Filters **(C)**. This unit do not require an Air lubricator

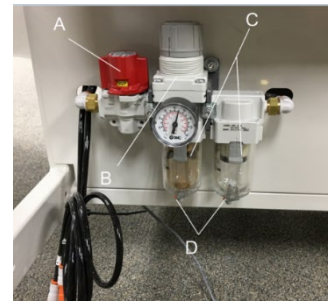

1. Pressure Relief Valve

Single action operation with a simple turn. It isolates the supplied pressure in the pneumatic system and exhaust downstream pressure for maintenance purposes. The unit can be locked in the exhaust position. Air flow direction is easily identified by handle orientation and labelling. It is part of the FR



2. Pressure Regulator

The purpose of the regulator is to keep the operating pressure of the system (secondary pressure) virtually constant regardless of fluctuations in the line pressure (primary pressure) and the air consumption. The presser regulator is set to 90 psi.



3. Air Filters

Clean air from your compressed air system is essential for the safe and efficient operation of this equipment. This unit has 2 compressed air filters. They remove contamination from compressed air after compression has taken place.

Harmful contaminants like oil, dust, dirt, rust, and water-alone or in combination-can attack your system and clog sensitive pneumatic parts.

- It can reduce the efficiency of the unit.
- Wear out seals and erode system components.
- Increase maintenance and repair costs.

Air leaving a standard screw or piston compressor will generally have a high water content, as well as a high concentration of oil and other contaminants.

Condensate is drained manually by pushing the red bottom on the drain plug **(D)**. They require a regular maintenance schedule (i.e., once per shift).



3.3.2. Solenoid Valve Stacking Manifold

They are located inside the control box

Control System voltage 24DC

Each valve can be activated manually by pushing the blue bottom.

Red light means the valve is energized

Dwg 125394C
Valve Stack
Without Top Guide

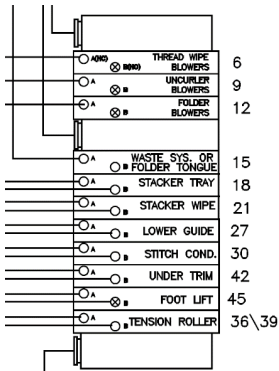

Dwg 125395C
Valve Stack
With Top Guide

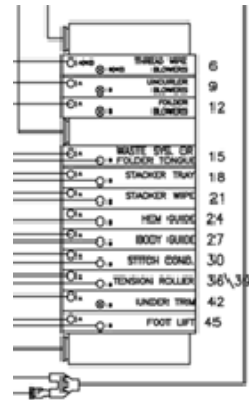

3.3.3. Air Pressure Switch.

It is located inside the control box. This Sensor is responsible for the detection of the secondary air pressure if it does not reach the pre-adjusted value. Connected to module #5 on the Serial bus system. For more details on connections, refer to the plumbing diagram located at the end of the Spare Parts Book. Part # AAVF51FM1B

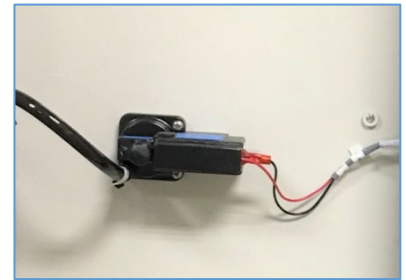

3.3.4. Waste Venturi

The purpose of the waste venturi is to pull the trimmings away as they're cut off of the shirt. The air flow should be enough to get the material from the head to the waste can.

- If it is set too high, it will pull the edge of the garment into the knife and cut a hole in it.
- The operator needs to make sure that the trimmings aren't very long because that can also pull the garment into the knife.



3.3.5. Pressure Regulator

Pressure regulator **(A)** controls the air pressure on the down side of the tensioning cylinder. Pressure value is indicated on manometer A

Pressure regulator **(B)** controls the air pressure on the up side of the guide wheel cylinder. Pressure value is indicated on manometer B

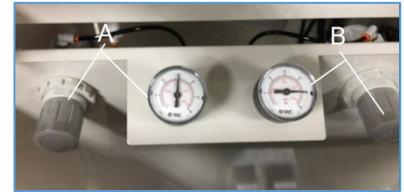

1. Tension Bar Cylinder

Apply tension on the shirt to control it.

Normal setting is 15 psi. The pressure should be sufficient to keep the shirt on the rollers and under control without excessive stretching.

Glass Lined expansion cylinder part # AACE9D0.5U

- If the pressure is too low, the shirt won't stay on the rollers and the guide wheel can't control the shirt.
- If the pressure is too high, the shirt will be stretched and the finished hem will be wavy. The guide wheel will have a hard time guiding the shirt because of the tension.

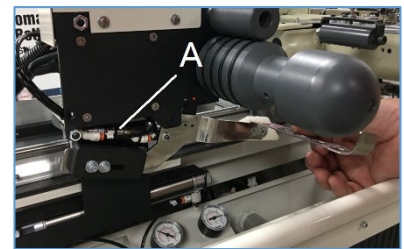
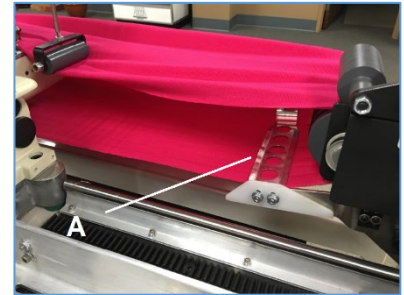

2. Lower Guide Cylinder

Apply pressure to the wheel that puts on the material to guide it. Normal setting is 20 – 25 psi.

The pressure should be enough to keep the wheel in contact with the plate.

- If the pressure is too low, the wheel won't put enough pressure on the material to move it as needed. The wheel will brush the material instead of moving it. This will cause lower guide jam errors because the material doesn't move in response to the wheel.
- If the pressure is too high, the wheel will stretch the material as it is sewing and will affect the hem size consistency and the end seam alignment. It can also cause problems at the edge trimming knife.

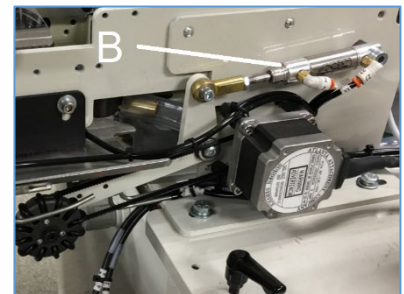
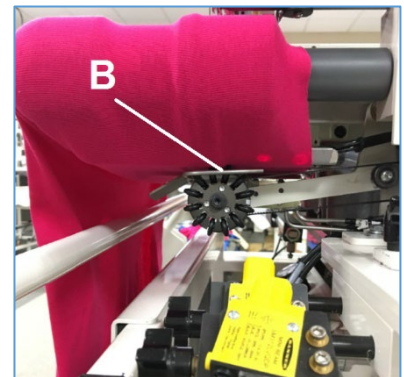

3.3.6. Blowers

In front of guide

Air in front of guide is the last jet to get the curl out before the guide uncurling flag. It is aimed to blow down across the beveled surface of the right roller.

The air flow should be enough to uncurl the material as it passes the air jet.

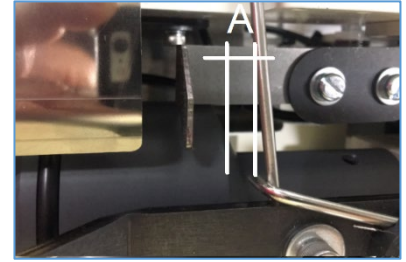

Flow to Low:

If it is too low, the material will remain curled up and may get sewn into the seam curled.

Flow to High:

If the flow is too high, it can affect the lower guide wheel control of the material.

Outer Uncurl Jets

Outer uncurl jets make the edge of the material lay out flat so the raw edge eye #1 can see it. It controls the lower guide wheel direction. The air flow should be enough to uncurl the edge of the material so the guide wheel can control the material accurately.

Flow to Low:

If the flow is too low, the material edge will be rolled and there will more material in the system than the guide can uncurl and it will be sewn into the hem.

Flow to High:

If the flow is too high, the guide wheel will be pulling more material out of the system to overcome the material pushed in by the jet.

Inner Uncurl jets

Inner uncurl jets mainly there for reverse curl material. With standard curl material, they can be turned off. They are usually set at a minimum to aid the guide wheel.

Flow to Low:

Nothing happens if the flow is too low.

Flow to High:

If they are set too high, the edge guide eye may not see the seam beginning and fail to shift the control to the hem edge guide eye # 2. Then the material will continue to run over and over.

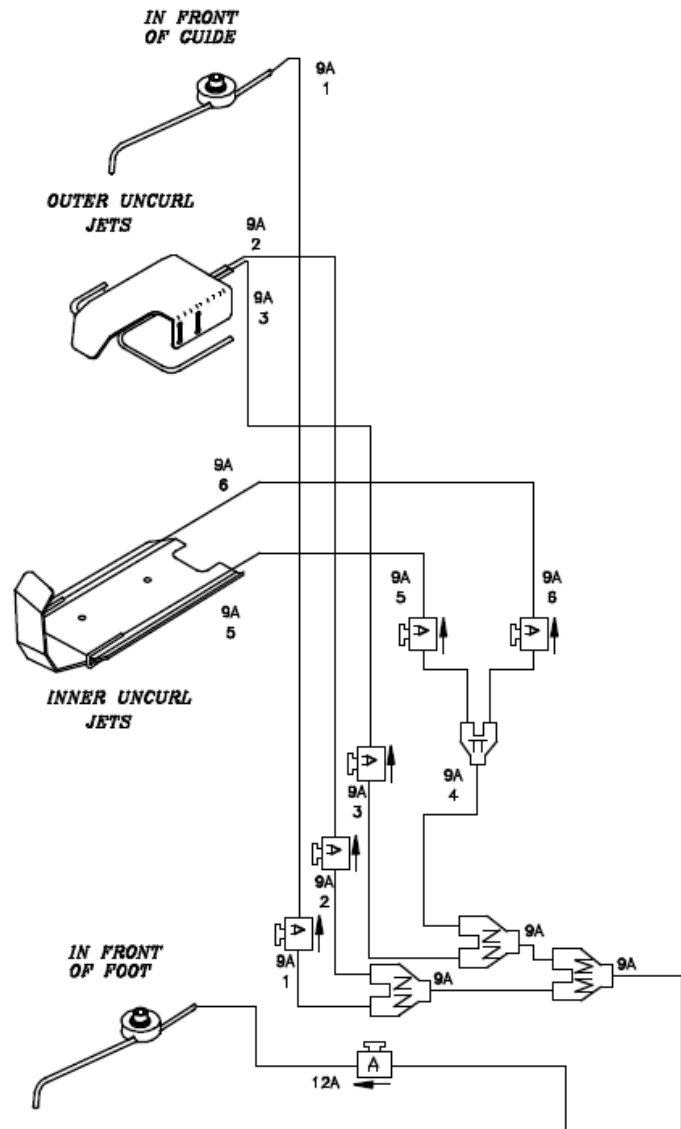

Service Instructions

In front of the foot

Air jet in front of the foot is used to help get the material under the foot. It is aimed across in front of the foot to help get the material over the knife and under the foot.

Flow:

The flow should not be aimed down into the edge guide because it will cause misalignment at the over-sew. The flow should be light because it's only used to get the material under the foot

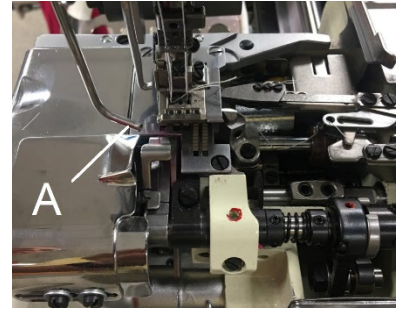

3.4. Electrical

NOTE: All maintenance should be performed by a qualified service technician.

3.4.1. Ground

This unit need to be connected to ground (earth) for several reasons. In mains powered equipment, exposed metal parts are connected to ground to prevent user contact with dangerous voltage when electrical insulation fails. In electrical power distribution systems, a protective ground conductor is an essential part of the safety Earthling system. Connection to ground also limits the build-up of static electricity



3.4.2. Main Circuit Breaker

The main power On/Off switch is on the inside of the control Panel. It is used to turn the power on to the whole machine. This machine requires 220V Single Phase. If you have problems with the power not coming on when the ON button is pressed you may check this switch by doing the following.

ATTENTION. Make sure that the machine is unplugged before proceeding and that all lock out/tag out procedures have been correctly followed (See to Lockout tag out procedure)



3.4.3. Main Power Contactor.

When you press the green button, it activates the contactor to turn on the power to the machine. It also functions to protect the unit after a power failure. It will keep the machine without power until the green START button is pressed.



3.4.4. Knife Switch

Control that the cutting cycle is finished. If sensor is not activated after thread trimming machine will not run

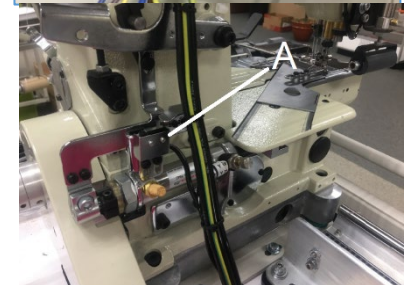

3.4.5. Electric Eyes

Raw Edge Eye #1:

The function of eye number one is to control the position of the raw edge of the fabric at the lower guide wheel. This ensures there is enough fabric on the right roller to allow for proper hemming. This eye controls the lower guide until the beginning of the seam is detected.

The setting of eye number one should position the raw edge of the garment one hem width plus 1/4" to the right of the folder back plate. For example, the setting of eye number one for 3/4" hem width is one inch to the right of the folder back plate. Eye number one should be adjusted far enough to the right to insure that the general motion of the upper guide is pulling the fabric out of the folder.

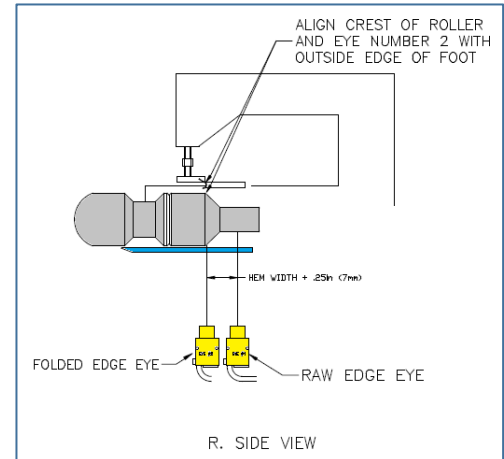

Folded Edge Eye #2:

The function of eye number two is to control the position of the folded edge of the hem on the right roller. This aligns the hem with the edge guide at the presser foot for proper over-sew.

This eye controls the bottom guide from seam detection to the end of the cycle.

The setting of eye number two should position the folded edge of the hem approximately aligned with the edge of the taper on the right roller, approximately aligned with the right edge of the foot. If this eye is adjusted too far to the right it can cause the finished hem to be double folded, and consequently cause a misalignment of the over-sew, and over-sew length to vary.

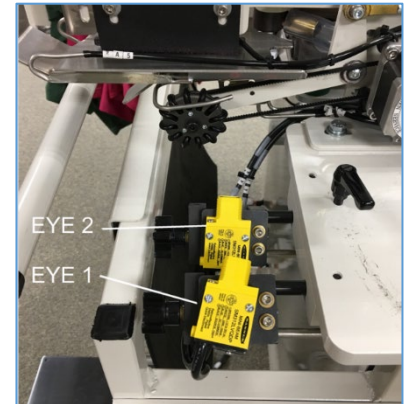

Upper Guide Eye #3:

Note: Only apply to machines with a top guide

The function of eye number three is to control the position of the raw edge of the fabric under the tongue of the folder. During the automatic sew cycle eye number three controls the upper guide wheel until the folder tongue is retracted.

The setting of eye number 3 is typically in the center of the needles. Moving the eye to the left leaves more of a raw edge outside of the cover stitch (a fuller seam).

NOTE If the gain setting on eye #3 is set too low it will result in inconsistent control of the raw edge by the upper (Upper) guide. If the gain setting of eye #3 is too high the eye may reflect off of the piece.

Hem Detect Eye #4:

The function of eye number four is to detect the start of the seam as it come over the right roller. During the automatic sew cycle; eye number four remains dark until the start of the seam passes the reflector tongue, then eye number four goes light. Once eye number four goes light, the machine begins counting stitches to the end of the cycle. Eye number four is disabled until the lower seam detection occurs.

The setting of eye number four is in the extreme upper left corner of the reflector tongue. If it is set too low, the eye may uncover prematurely, causing variations in the over-sew length.

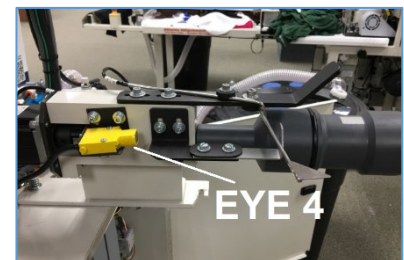

Service Instructions

Eye Sensor Adjustment

Remove the clear plastic cover from the end of the sensor. There are two adjusting screws under the cover. One is labeled “GAIN” and is used to set the sensitivity of the sensor. The other screw is labeled “DO & LO” and should always be fully clockwise.

With the end of the sensor pointing at the center of the reflective tape, turn the “GAIN” screw counter-clockwise until the red LED indicator is off

Then turn the “GAIN” screw clockwise until the LED indicator comes on.

Then turn the “GAIN” screw one full turn clockwise. The LED indicator should be blinking slowly approximately 2 pulses per second. The eye on the hand wheel should be at least 2 full turns. Cover the eye so that the sensor cannot see the reflective tape and the LED should go off.

Part #FFSM312VQ

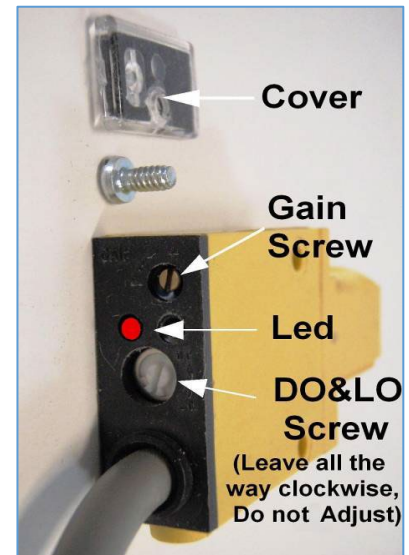

Reflective Tape Maintenance

Use a soft cloth for cleaning. Do not use chemicals or abrasives to clean it. Avoid any contact with oils and liquids. Do not touch the tape with bare fingers. If tape is dirty or opaque, the eye may not function correctly.

3.4.6. Fiber Optic Eye

Note: Only apply to machines with a top guide

Fiber optic eye #3 in the folder: Make sure the fiber optic leads are inserted as deep as possible within the sockets of the black clamp attached to the eye. With the folder tongue “in” and the fiber optic cable looking through the slot in the bottom of the folder and reflecting off the tape on the bottom of the tongue, insert a piece of white paper between the tongue and folder bottom. Increase (turn clockwise) the gain screw until the red LED turns on. Keeping the paper in place, slowly decrease (counterclockwise) the gain screw until the red LED turns off. Then turn the gain screw one-quarter turn counterclockwise. Check the adjustment of the eye. With the tongue engaged, the red LED should blink two to three times per second and should go off when white paper is inserted into the folder. Be sure the “LO_DO” screw is fully clockwise.



3.4.7. Tension Sensor Switch

The tension sensor switch is a proximity switch mounted on the back side of the left roller assembly plate. It is covered and uncovered by an adjustable tab mounted on the tension arm. When is covered, the light on the sensor is lit and can be seen through a small hole in the plate. When the shirt is loaded onto the rollers, the left roller moves to the left and the tension arm drops, uncovering the sensor. When the tension of the shirt is enough to pick up the arm and cover the proximity switch, the left roller stops moving, and the pre-feed jogging begins.

- If the shirt doesn't have enough body to overcome the tension arm pressure, a tension arm timeout error will appear.
- If the proximity switch doesn't uncover and recover, the error will appear also.

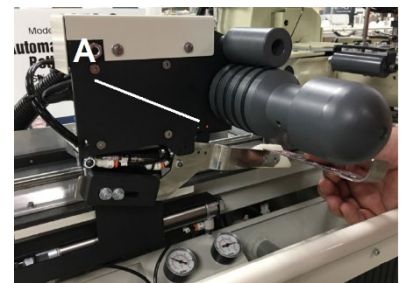

3.4.8. Thread Break Detectors.

3. Lopper Thread Sensor

This type of thread detector monitors the consistent movement of thread at a 5 degree angle (see picture) over a ceramic surface. With the unit running in manual mode, the three LED's on the detectors must not be on. The presence of a red light on any of the detectors indicates thread breakage or misadjustment, thus causing the unit to stop. Part # 011-132A

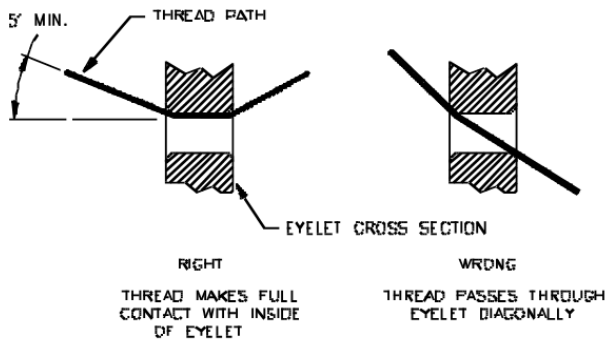

CROSS SECTION OF THREAD EYELET SHOWING RIGHT AND WRONG THREAD PATH.

Adjustment.

To adjust thread detector, switch control panel to manual. Depress the chain switch to make unit run and chain-off. Take precaution that the chain is under chain puller before running. Looking at the face of the thread detector with unit running in manual chining mode, turn blue nylon screw (see Fig. 2) counterclockwise until you see the LED light up. Turn screw clockwise until LED goes out. Turn 1/16" more CW.

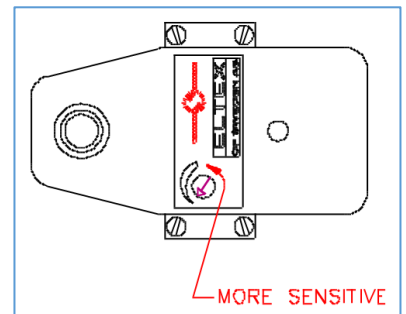

4. Needle Thread Sensor

Part Number: (4003-3WT2)

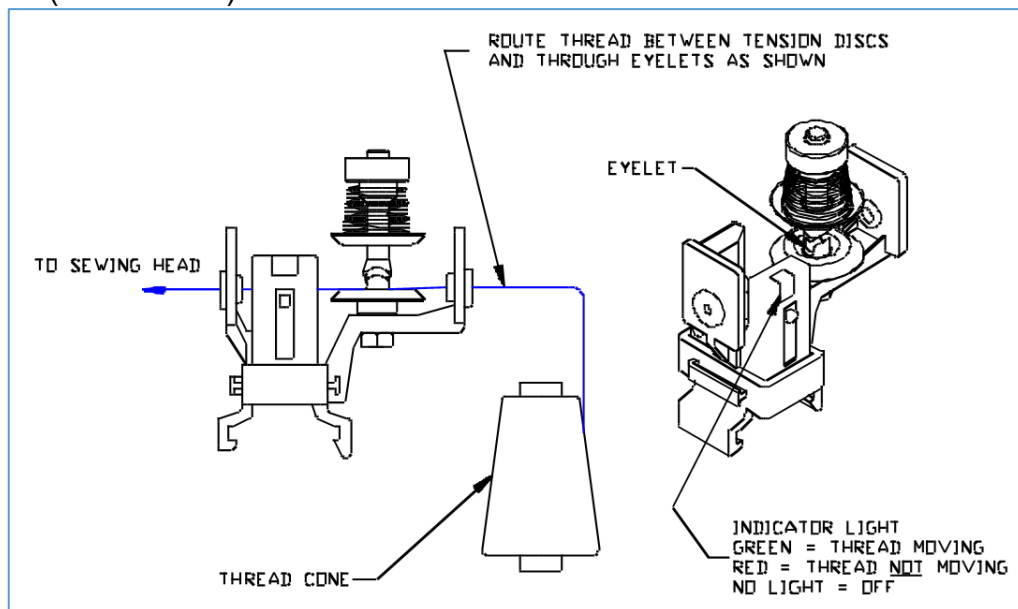

3.4.9. Stepping Motors

There are 3 stepping motors in the machine. Left Roller, Lower Edge Guide and Right Roller all three controlled by one Stepping Box AP-28_800T

The left and right rollers are driven synchronously with the sewing head.

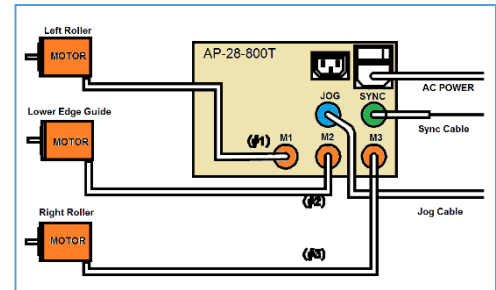

1. Rollers Motors

The thumbwheel switches on the front of the control box set the speed of the rollers A and B when the head is sewing. During the loading cycle, the rollers are driven by the jog signal. They are set at 200 rpm using the front potentiometer in the box.

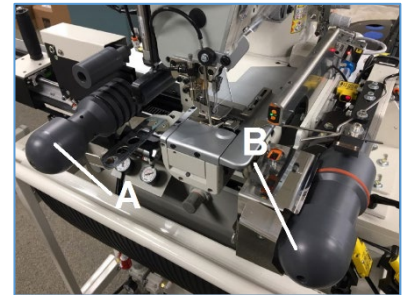

2. Lower Edge Guide

The lower guide wheel E runs when the rollers run. It runs at a constant speed of 80 rpm using the back potentiometer (A) in the box.

The guide wheel direction is controlled by eyes 1 & 2, depending on the cycle.

During loading and initial sewing, eye # 1 looks at the raw edge of the material.

The wheel moves the material to cover the eye when it is uncovered, and moves the material to uncover the eye when it is covered.

The wheel should appear to oscillate as the shirt is sewn.



When the hem beginning comes to EYE # 1 and it is detected, the guide wheel control shifts to EYE # 2.

It reads the hemmed edge of the material and controls it to the end of the cycle. I

- If the wheel is turning in one direction more than the other, there may not be enough pressure on the material to control it.
- If the material is pulled off of the roller, check EYE # 1 to make sure it is seeing the tape on the edge of the plate.

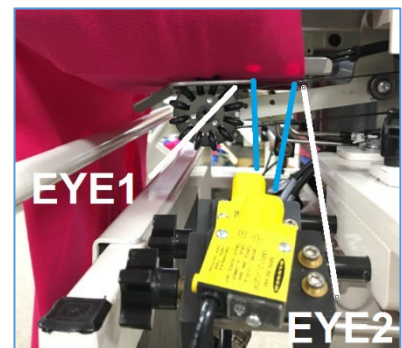

Service Instructions

3. Speed of Feed vs. Speed of Rollers

In normal operation, it is necessary to have the feed rollers of the machine synchronized with the feed dogs. The unit should sew approximately the same stitch length in manual sewing as in automatic. If the synchronization is improperly set it can adversely affect the alignment of the over-sew and the quality of the sewn hem.

Feeding At a Faster Rate

If the feed rollers are feeding at a faster rate than the feed dogs, the fabric will pull away from the edge guide at the foot when the folder tongue retracts.

The fabric between the foot and the left roller will also become stretched during sewing causing the hem to pucker.



This will cause a more narrow hem and misalignment of the over-sew.

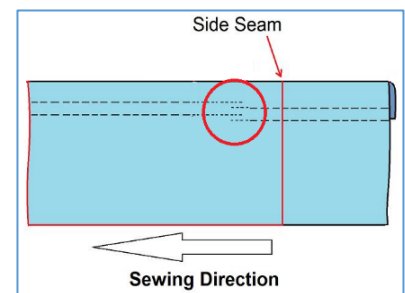

Feeding At a Slower Rate

If the feed rollers are feeding at a slower rate than the feed dogs, the fabric will be loose between the right roller and the presser foot. The fabric will appear to bunch up behind the presser foot.



This causes a stitch and over-sew misalignment. Shirring can also contribute to alignment problems. Be sure that all shirring is eliminated from the feed dogs.

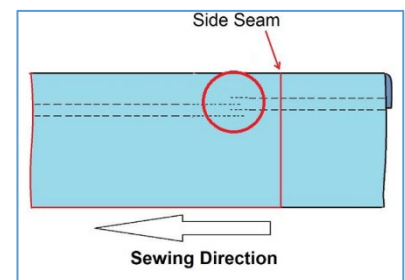

3.4.10. Stepping Motor Control Box

The control box powers the Feed Rollers and the Lower Edge guide. The amber light show that the box is energized. Part Number AP-28-800T)

1. JOG button

Pressing the JOG button will turn on the roller motors. The three thumbwheels on this box are used to synchronize the two rollers with the sewing head.

2. Thumbwheels

The thumbwheels on the box adjust the synchronous speed of the feed rollers while sewing (typically set to 12 for 10 spi).

- If you change the RPM of the sewing head, there is no need to adjust the thumbwheels; they will remain synchronized to the head.
- If you change the sewing stitch length, it will be necessary to adjust these numbers to re-synchronize the rollers with the sewing head.
- Decreasing the number makes the rollers go slower. For example, if you changed the stitch length from 10 SPI to 11 SPI, you would need to decrease the number in the thumbwheels by 10% to match the 10% shorter stitch length.

3. Potentiometer

Inside the box there are 2 small potentiometer

- B: . It sets the pre-feed JOG speed of the feed rollers typically set to 200 rpm at the roller.
- A: It sets the JOG speed of the Lower Edge Guide normally set to 80 rpm at the wheel

4. Jumpers

The direction of rotation of the feed rollers is controlled by the CW/CCW jumpers on the driver boards inside the box and should be set CCW. There are jumper clips for setting the motor currents on each driver board. The feed roller drivers are set to 2A.

- The top driver board powers the left feed roller and
- The bottom driver board powers the upper guide wheel.

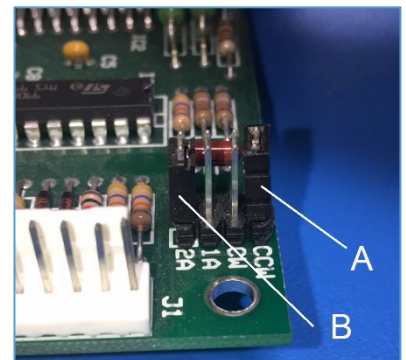
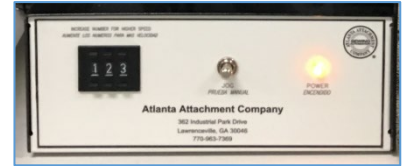
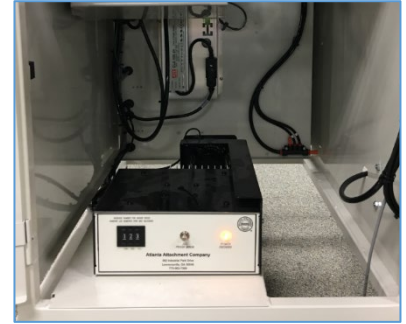

Service Instructions

5. Power

The back of the boxes has an On/Off switch (A) , fuse (B) , JOG cable (C), 3 stepping motor cable (D) and Sync cables (E) .
Leave the On/Off switch ON all the time.

NOTE: When working on the box always disconnect the power cord before servicing.

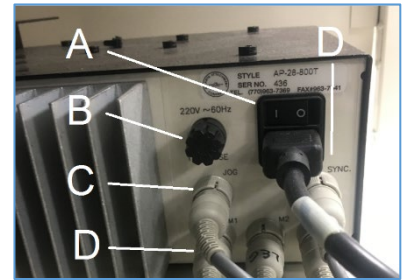

3.4.11. Secondary Stepping Motor Control Box

Note: Only apply to machines with a top guide

The bottom control box powers both guide wheels. Pressing the JOG button will turn on the lower guide motor. Inside the box are 2 small potentiometers for adjusting the JOG speed (typically set to 80rpm). The direction of rotation is controlled by the computer box. There are jumper clips for setting the motor currents which should be set to 2A (1 ampere).



3.4.12. Efka Sewing Motor

1. Programming the Code Number

NOTE: The parameter numbers in the illustrations below serve as examples and may not be available in all program versions. In this case, the display shows the next higher parameter number. See List of Parameters. If you have a screen with 4 digits your access code will be 3112 instead of 311

2. Parameter Settings EFKA DC1500

PARAMETER	RANGE	VALUE	DESCRIPTION
Do this first	*****	****	Perform a master reset before programming, see below
290		5	Mode of operation. MUST SET THIS PARAMETER FIRST!
026		0	Treadle mode
111	200-9900 rpm	5000	Maximum speed when "129" is 0, 1, or 2.
161	0-1	1	Motor rotation, 0=cw/1=ccw
204	0-100	100	foot lift modulation.
270		1	Position Sensor
272	020-255	1000	Drive ratio between motor pulley and handwheel pulley. If handwheel pulley is smaller than motor pulley, increase this value to slow down sewing head until measured speed matches speed set with parameter 111. (For Yamato and Pegasus, setting should be 100; for Rimoldi, setting should be 124)
436		0	Use code "5913". This disables an input that was causing box to reset itself.
401		0-1	Save parameters
Front panel LED's:			To Perform Master Reset of Parameters:
LED 1:	Off		1. Power on holding down the "P" button till "COD" is displayed.
LED 2:	Off		2. Press ">>" once and enter the number "5913"
LED 3:	Off		3. Press "E" twice and "093" is displayed.
LED 4:	Off		4. Press "+" once, "094" is displayed.
LED 5:	Off		5. Press "P" to exit programming mode with all default values.
LED 6:	Off		
LED 7:	Off, Stop at needle down.		
LED 8:	On, Stop at needle up.		Programming Instructions:
			1. Power on holding down the "P" button till "COD" is displayed.
			2. Press ">>" once and enter the number "5913"
			3. Press "E" once and "2.0.0." is displayed. This is a parameter.
			4. Press "E" again and the value for parameter 200 is displayed.
			5. With the value on the screen, adjust to desired setting.
			6. Press "E" to enter value and continue with parameter setting.
			7. Repeat for other parameters, press "P" once when complete.
			8. Run sewing head to save parameters before powering down

3.4.13. Panasonic Motor Sewing Motor

1. Programming D9 Motor

1. Turn off power to machine.
2. Hold Up Arrow button, Turn on the power
3. Display shows Axxx
4. Use + & - buttons to scroll to desired parameter #.
5. Press > to toggle to parameter value.
6. Displays shows the parameter value xxxx.
7. Use + & - buttons to change parameter value.
8. Press enter (E) button to save change.
9. Press > to toggle to back to parameter number.
10. Use + & - buttons to scroll to next desired parameter #.
11. Repeat until all desired parameters are updated. Be sure to press enter (E) after changing the parameter values.
12. Turn off the power momentarily.
13. For 1278-8 set the following parameters:
 - A 27 = 1 (Stop needle up)
 - A 29 = 1 (Rotation, 1 CCW, 0 CW)
 - A 70 = 5000 (max speed)
 - A 91 = 1 (Pneumatic solenoid foot lift, 100% modulation)
1. Turn off power to machine.
2. Hold "E" & "-" buttons, Turn on the power
3. Use + & - buttons to change parameter value to F166.
4. Press > to toggle to parameter value.
5. Use + & - buttons to change parameter value to 600 (one minute foot time-out).
6. Press enter (E) button to save change.
7. Turn off the power momentarily.

2. Programming D7 Motor

Apply to Small Programmer Mpur01a10

NOTE: to adjust parameters after initial programming, start with step number 10

1. Turn off power to machine.
2. Plug in the small Panasonic programmer.
3. Hold ENTER and MODE "+", Turn on the power. Continue holding down buttons for 8 seconds, until 106 Y2 is displayed on screen.
4. Double-click the "ENTER" button to exit parameter mode.
5. Turn off the power.
6. Turn the speed control on the motor to the minimum.
7. Turn on the power.
8. Run the sewing head for a few seconds (at least 5) to set the pulley ratio in the Panasonic Motor. Pressing the sew pedal will cause the head to sew.
9. Turn off the power.
10. Turn on the power.
11. Press MODE "+" several times until the word parameter is displayed on the screen.
12. Double-click the "ENTER" button to enter parameter mode.
13. Using the MODE "+" and "-" buttons to locate the parameter and the DATA "+" and "-" buttons to adjust the individual parameter, set the following parameters:
 - 135 = desired RPM
 - 605 = 64 (foot modulation On-time)
 - 606 = 1 (foot modulation Off-time)
14. (Refer to this step only for Pegasus Machines with a hall effect undertrimmer sensor) Set parameter 011 equal to 131. (011=3 is default)
15. (Refer to this step only for Rimoldi Machines with a hall effect position sensor) Set parameter 520 equal to 1 and parameter 523 equal to 222.
16. Double-click the "ENTER" button to exit parameter mode.
17. Turn off the power.
18. Turn the speed control on the motor to the maximum.
19. Turn on the power.
20. Test RPM of sewing head with tachometer.
21. The sewing speed shouldn't exceed the setting in parameter 135

Start delay from lifted foot is parameter 603, and is typically set at the factory default.*

Reset sequence for large programmer:

Hold the "A", "B" and "ENTER" buttons, while turning on the power, wait 5 sec.

Press the enter button.

Parameter programming sequence for large programmer:

Hold the "D" and "ENTER" buttons, while turning on the power, wait 5 sec.

Press the enter button.

Press the backtick buttons (the two buttons on the bottom right of the programmer)

Use the "A" and "B" buttons to locate the parameter (see step 13 above) and "C" and "D" to adjust the individual parameter (see step 13 above)

3.5. Serial Bus

The Serial Bus System, based on only four wires, is self-diagnostic and offers helpful solutions to solve the problem. An operator using a touch screen control panel manages this rugged, uncomplicated system. Designed to international standards, this multi-lingual, easy to operate interface will allow parameters to be saved, allow technician access with password protection and offers a built-in production performance monitor which can be networked to a central computer.

A warranty of 3-Year covers all electrical components of the state-of-the-art Serial Bus Control. Controller part number is 4080-004



3.5.1. Touch Screen

Caution: Do Not Use Any Sharp Objects To Touch The Screen

1. Calibration

If you are having troubles locating the right place to get access to the function by touching the screen a screen calibration may be required.

Proceed as following:

1. Place one finger on the screen and hold it there while pushing the Green ON button.



2. When the screen turns light, remove your finger and the screen will display two lines, one vertical and one horizontal, intersecting at the top left corner. The text "Touch at the crossed lines to calibrate display." should appear in various languages. In older machines, there will be no text. Using a small pointing device that will not puncture or damage the screen (such as a pencil eraser), touch the screen where the two lines intersect. Do this with as much accuracy as possible.

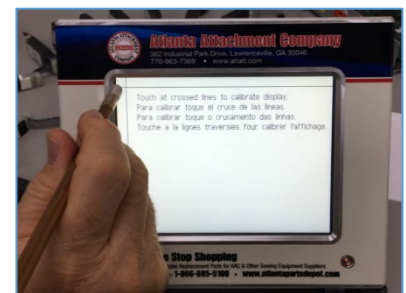

3. When the screen is touched, the display will change to two lines intersecting at the lower right of the screen **NOTE:**

The implementation of step 2 and step 3 directly affects the validity of all the buttons in the entire program. It is very important to be accurate.

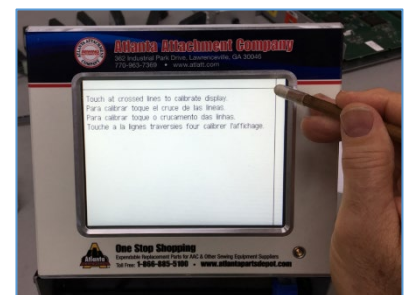

- Repeat step 2 where these lines intersect. On 004 screen all 4 corners need to be adjusted

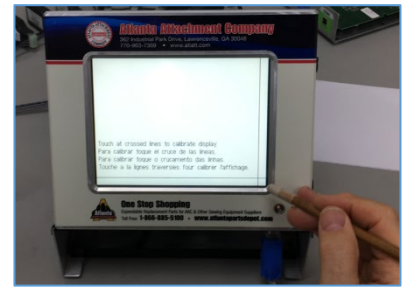

- Press the language button of your choice.

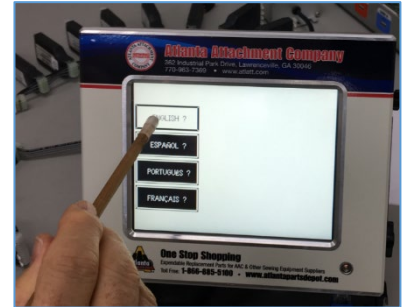

- Press the RESET button at the lower left corner of the screen. See figure.

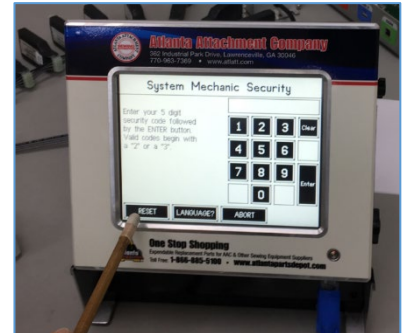

2. Installation

To install new screen you must follow these directions.

- Install new screen and turn power on
- When screen displays "Fatal Error Message" press continue
- Enter Mechanic Security Code
- After reading the "Warning Message" press continue again
- Screen will begin to process the up-loading of existing program. This will take 60 - 90 seconds
- After reading the "Last Warning Message" press continue again.
- Screen will begin to process information again for 15 - 30 seconds
- Reset routine will follow.
NOTE Machine assemblies will reset or move to home positions
- Screen will return to the Main Display and is ready to run.

3.5.2. Modules

1. Program Module...4080-150

Stores the program information. It is also used to load program modifications or updates. For update procedures please refer to next chapter.

2. Module Data...4080-930

Stores the unique data required to operate this particular machine; such as serial number, original factory parameters, etc. This module should never be exchanged with another machine.

3. Output Module...4080-140

They are responsible for transferring signals from the computer to the working elements such as valves, motors and relays, etc.

4. Input Module...4080-110

They are responsible for transferring signals from the machine to the computer such as switches, electric eyes, sensors, etc.

5. Input Module...4080-120

They are responsible for transferring signals from the machine to the computer such as external relays. (Electrically insulated)

6. Output Module ...4080-130

They are responsible for transferring signals from the computer to external connections, servo motor controls (electrically insulated)

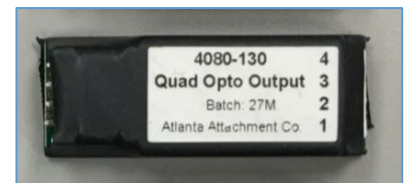
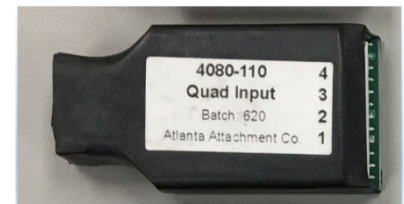
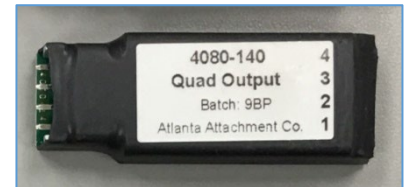

NOTE: Even though all output and/or input modules within the machine are identical, they cannot be moved to another location on the serial bus cable, as the computer automatically assigns a working address for each one.

- If a replacement is necessary, always replace with a new or loaner module from another machine.
- Electrical Power to the machine must be turned "OFF" during replacements.
- Computer will show an error if one or more modules are missing.
- Removing more than 1 module at a time will require reinstalling all of the modules

Procedure:

Remove the old module and connect the new one, after turning on the power, the computer will reassign the address to this new module.

3.5.3. Program Update

NOTE: Very Important

Before starting the procedure below, go to Advanced Settings and write down all the settings shown in these screens.

1. Turn off power to the machine.
2. Replace the existing Program Module with the Program Module that contains the updated program.
3. With your finger on the screen, turn power on to the machine. When the screen changes from dark to light, remove your finger from the screen.



4. Carefully calibrate the screen. See screen calibration.

ATTENTION: Do not turn off the machine during this process for any reason, as vital information will be corrupted and it will be necessary to the call manufacturer for assistance and/or return the touch screen and module for base programming.

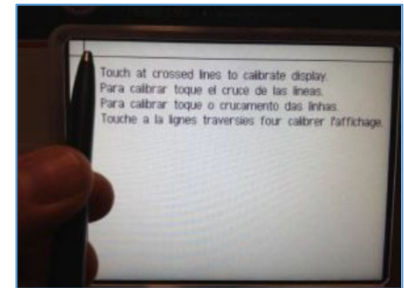

5. Press the “Update Controller” button. Input mechanic security code **xxxxxx**. This process takes up to 5 minutes and asks you to press the “Continue” button once during this time.
6. When complete the Controller will contain the updated program.

NOTE: Continue to item 7 only if you need to reprogram original module.

7. Turn off power to the machine.
8. Replace the Program Module that you installed in step #2 with the original Program Module that came with the machine.
9. With your finger on the screen, turn power on to the machine. When the screen changes from dark to light, remove your finger from the screen.
10. Carefully calibrate the screen.
11. Press the “Update Program Mod” button. Input technician security code **xxxxxx**. This process takes up to 5 minutes. When complete the original Program Module that came with the machine and the Controller will contain the updated program.

Now that the process is complete, go to Advanced Settings and verify them using the settings you wrote down at the beginning of the process. Make any necessary corrections.

3.5.4. Technical Screens 1278-8-H Software

1. ADVANCED FUNCTIONS

Show ALL SETTINGS, ADVANCED SETTINGS and MACHINE DIAGNOSTIC

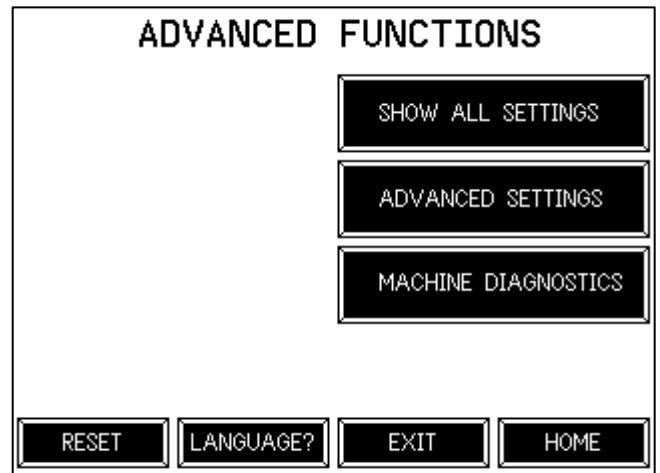

Sub Menus

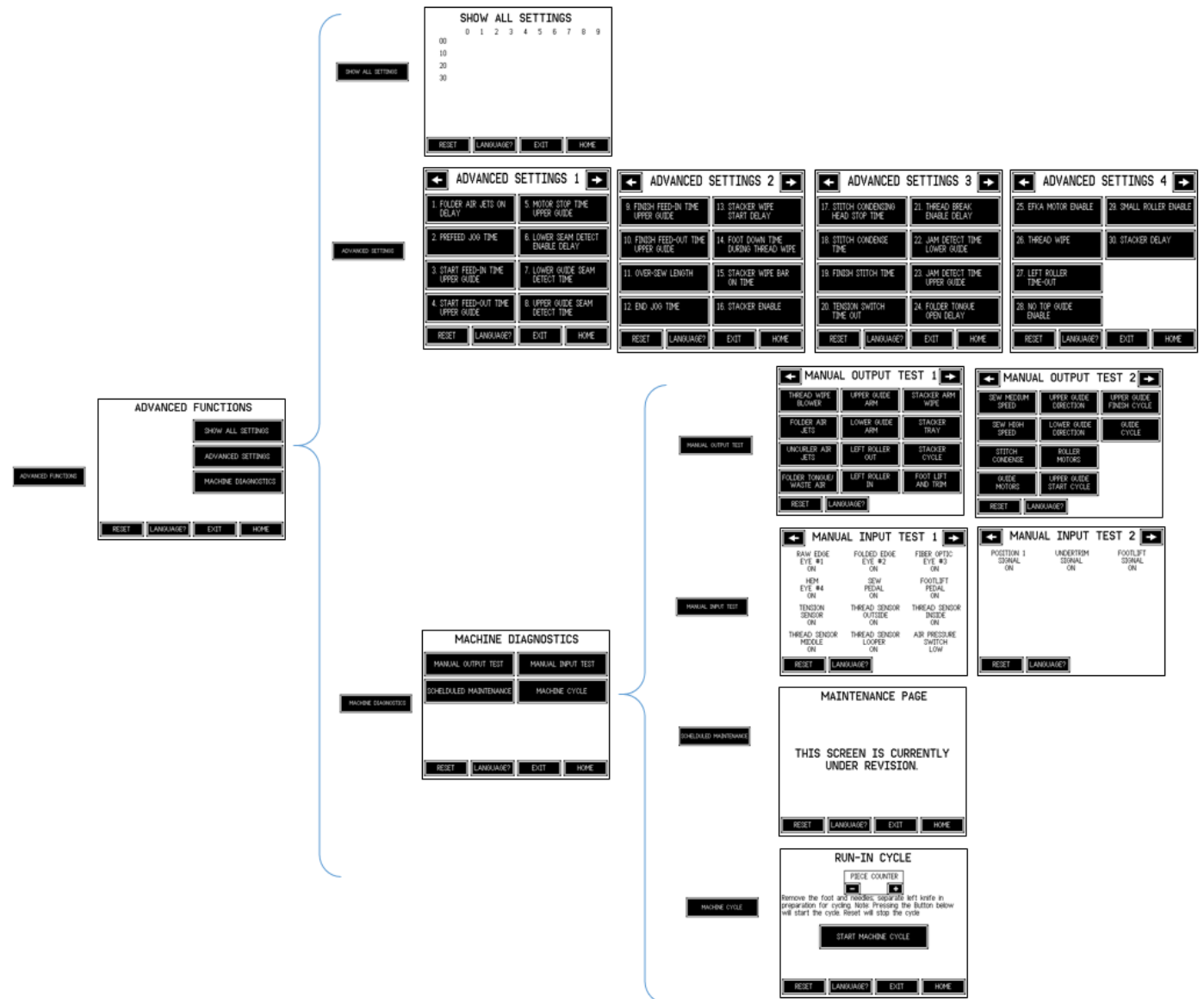

A. SHOW ALL SETTINGS

Shows the current parameter values being used by the machine. It doesn't show the function, only the value. Before any program or module change, take notes of these values or a picture in case of any program issues.

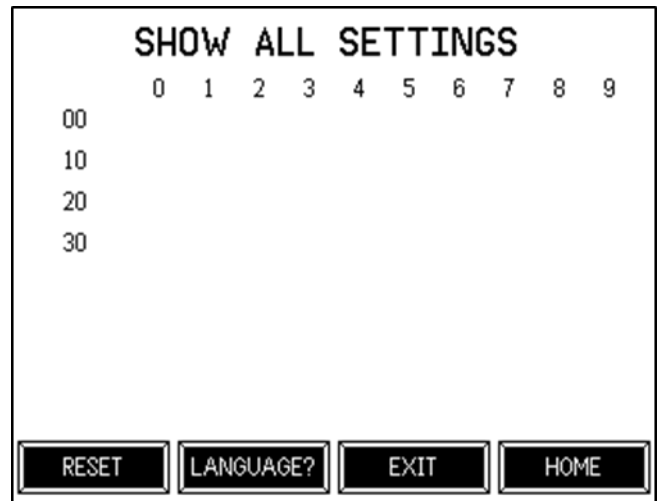

B. ADVANCED SETTINGS

This button selection gives access to all available settings for the machine..

NOTE: All buttons on Advanced Settings screens 1, 2, 3, and 4 take you to individual setting screens that will allow you to adjust the setting and will give a brief description of how the setting works.

ADVANCED SETTINGS 1

1) Folder Air Jets On Delay:

Note: Only apply to machines with a top guide Time from folder tongue in until folder air jets turn on. Adjust so air jets come on when the folder is completely engaged.

2) Pre-feed Jog Time:

Jog time of feed rollers until sewing begins. Controls start position of sewing and therefore the position of the over-sew stitches.

3) Start Feed-In Time Upper Guide

Wheel:

Note: Only apply to machines with a top guide The Feed-in time of upper guide wheel is active until eye #3 in folder goes dark (covers). Should always be set greater than Timer #4 feed-out time. Adjust with timer #4 to gently feed the garment during folder loading. Increasing the number feeds in faster.

4) Start Feed-Out Time Upper Guide Wheel:

Note: Only apply to machines with a top guide The Feed-out time of upper guide wheel is active until eye #3 in folder goes dark (covers). Should always be set less than Timer #3 feed-in time. Adjust with timer #3 to gently feed the garment during folder loading. Decreasing the number feeds in faster.

5) Guide Motor Stop Time:

Note: Only apply to machines with a top guide

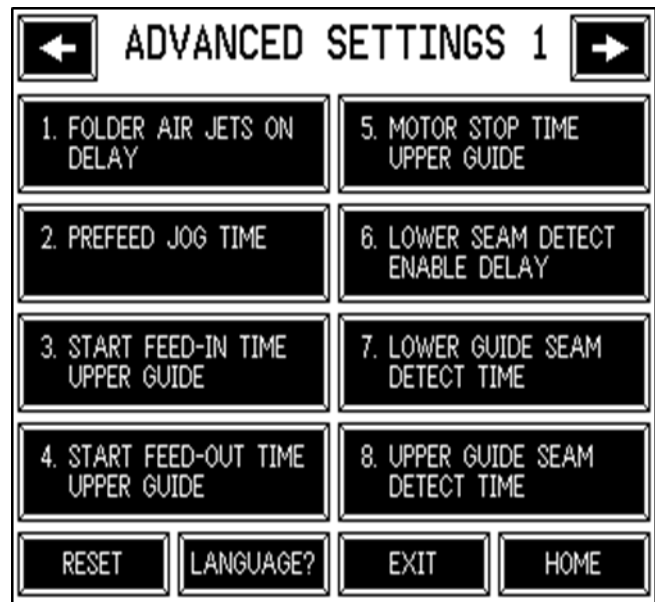

Service Instructions

The time the guide motors stop at beginning of sewing to prevent over feeding of upper guide during head acceleration.

6) Lower Seam Detect Enable Delay:

Lower seam detect is disabled for this time after start of sewing to allow guiding to stabilize. Usually set 1/4 to 1/2 of total sewing time.

7) Lower Guide Seam Detect Time:

Time eye#1 must stay light to cause a lower seam detect. Increase if seam detection happens too soon. Decrease if seam detection is missed. Must be set lower than timer #22 JAM DETECT LOWER GUIDE WHEEL.

ADVANCED SETTINGS 2

8) Upper Guide Seam Detect Time:

Note: Only apply to machines with a top guide
Length of time eye #4 must stay light to cause a upper seam detect

9) Finish Feed-In Time Upper Guide Wheel:

Note: Only apply to machines with a top guide
Feed-in time of upper guide wheel during over-sew, after folder opens. Should always be set greater than Timer #10 feed-out time. Adjust with timer #10 to gently push hem against edge guide during over-sew. Increasing number pushes hem harder.

10) Finish Feed-Out Time Upper Guide Wheel:

Note: Only apply to machines with a top guide
Feed-out time of upper guide wheel during over-sew, after folder opens. Should always be set less than Timer #9 feed-in time. Adjust with timer #9 to gently push hem against edge guide during over-sew. Decreasing number pushes hem harder.

11) Over-sew Length Adjustment:

Sewing time from upper seam detect to end. Controls the amount of over-sew stitches.

12) End Jog Time:

Time of roller feed after under trimming to pull stitch off of throat plate tongue. Can also be used to index garment to stacking position.

13) Stacker Wipe Start Delay:

Time between left roller retract and stacker wiper on. Adjust to remove tension from garment prior to Stacking.

14) Foot Down Time During Thread Wipe:

Timer that controls foot down time during thread wipe, foot bounce. Also is a part of wiper bar on time.

15) Stacker Wiper Bar On Time:

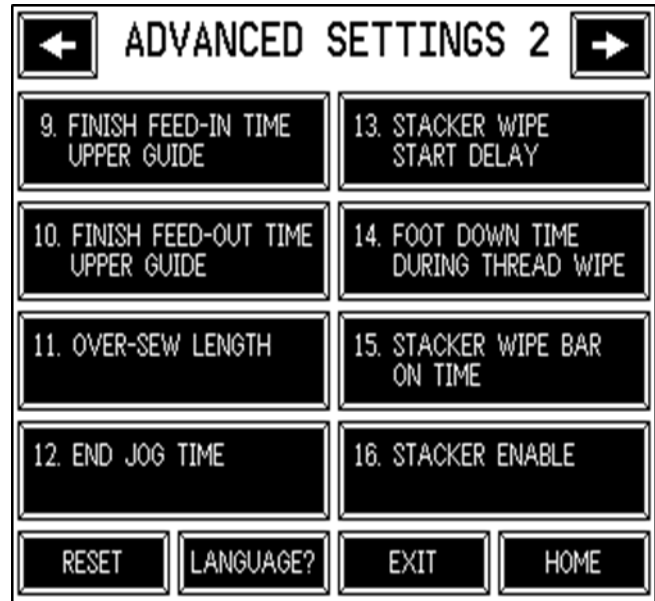

Service Instructions

This timer is used twice. It is the time from stacker wiper bar on during thread wipe. It is also the time from thread wipe foot up until stacker wiper bar off. Adjust so garment is pulled out from under foot by the stacker wiper bar before the foot drops.

16) Stacker Enable:

1-On 0-Off

Turns the stacker on./off.

ADVANCED SETTINGS 3

17) Stitch Condensing Head Stop Time:

Head stop time while stitch condense hardware shifts. Disabled if #18 STITCH CONDENSE TIME = 0.

18) Stitch Condense Time:

Time for condensed stitches. Condensing is disabled if set to zero.

19) Finish Stitch Time:

Time for final stitches after stitch condense. Disabled if #18 STITCH CONDENSE TIME = 0.

20) Tension Switch Time-out:

Time allowed for tension arm to drop before tension switch is enabled. If this timer times out then the left roller has not expanded and tension is not correct. Should be set as low as possible to activate tension roller without timing out.

21) Thread Break Enable Delay:

Delay time until thread breaks become enabled to allow sewing head to accelerate.

22) Jam Detect Time Lower Guide wheel:

The maximum time eye#1 can remain in one state (light or dark) before jam detection occurs. Must be set greater than #7 LOWER GUIDE SEAM DETECT.

23) Jam Detect Time Upper Guide wheel:

Note: Only apply to machines with a top guide

The maximum time eye#3 can remain in one state (light or dark) before jam detection occurs.

24) Folder Tongue Open Delay:

Note: Only apply to machines with a top guide

Time from lower seam detection until the folder tongue opens to allow seam to pass through the folder

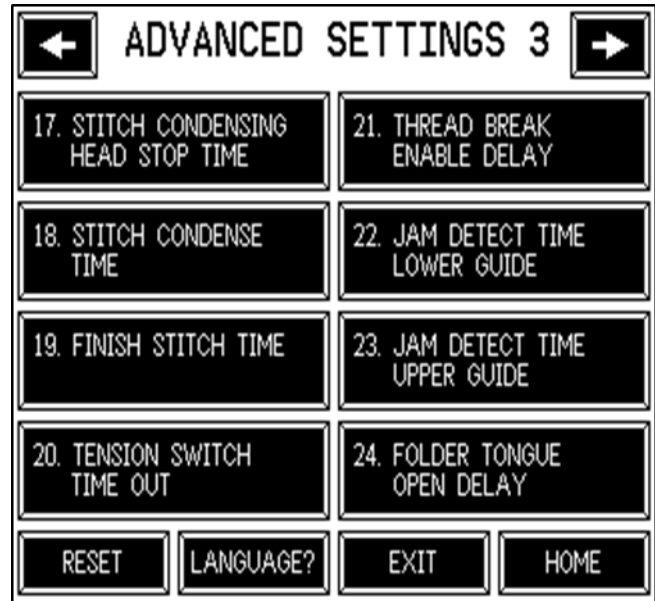

ADVANCED SETTINGS 4

25) Efka Motor Enable:

1= Efka Motor, 0= No Efka Motor

26) Thread Wipe:

1= Mechanical thread wipe enabled, 0= Air thread wipe enabled

27) Left Roller Time-out:

Length of time allowed for the tension arm to be lifted by the expansion of the left roller. If this timer times out then the left roller has failed to expand and lift the tension arm within the given time.

28) No Top Guide Enable:

1= No Top Guide, 0= Top Guide

29) Small Roller Enable

0= Disable- left roller will expand as normal

1= Enable- Left roller will not expand

When Enable left roller must be manually set to correct position before the shirt is loaded

C. MACHINE DIAGNOSTICS

This button takes you to the Machine Diagnostics screen. In the Machine Diagnostics screen the mechanic can access the Manual Input Test or the Manual Output Test.

MANUAL OUTPUT TEST 1

All objects on the Manual Output Test screen are buttons that manually activate that particular device or cycle.

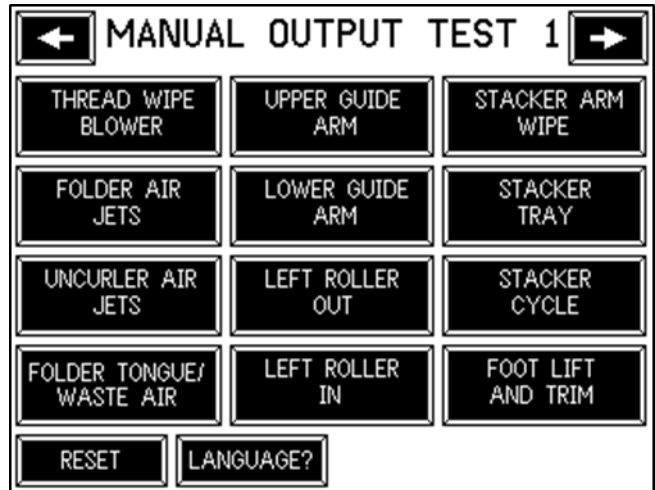
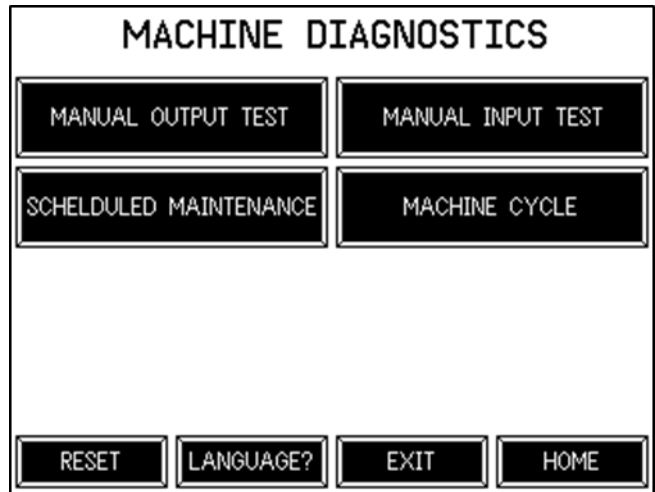
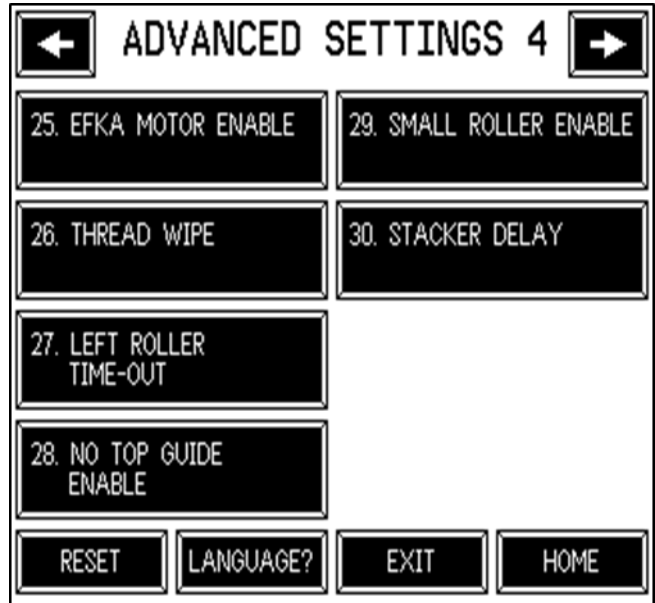

Service Instructions

MANUAL OUTPUT TEST 2

All objects on the Manual Output Test screen are buttons that manually activate that particular device or cycle

Will allow the manual activation of the cylinders, solenoids, and motors.

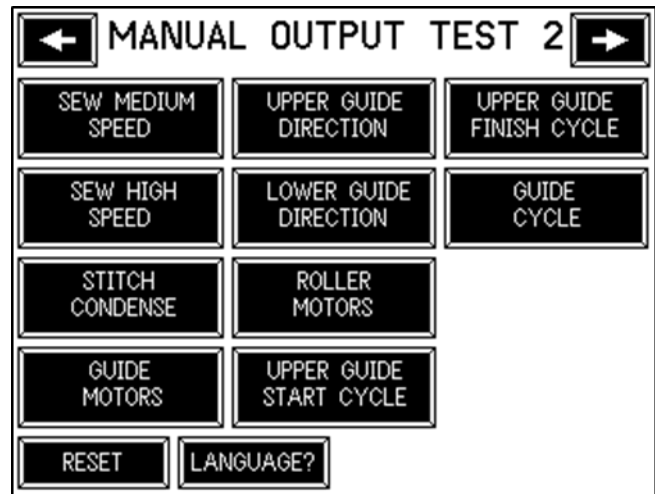

MANUAL INPUT TEST 1

While testing input devices the machine WILL NOT start in automatic mode.

A rectangle around the name of an input device is used to denote a change in its state. When an eye is covered, a change in state will be shown on the screen.

An example is when you manually cover the RAW EYE #1 a rectangle appears around the name RAW EYE.

The eyes, foot pedals, and proximity switches can be checked.

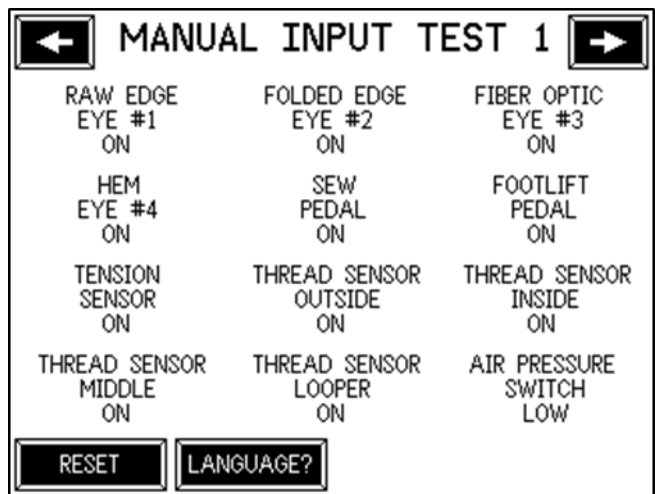

MANUAL INPUT TEST 2

While testing input devices the machine WILL NOT start in automatic mode.

A rectangle around the name of an input device is used to denote a change in its state. An example is when you manually cover the sew eye a rectangle appears around the name SEW EYE.

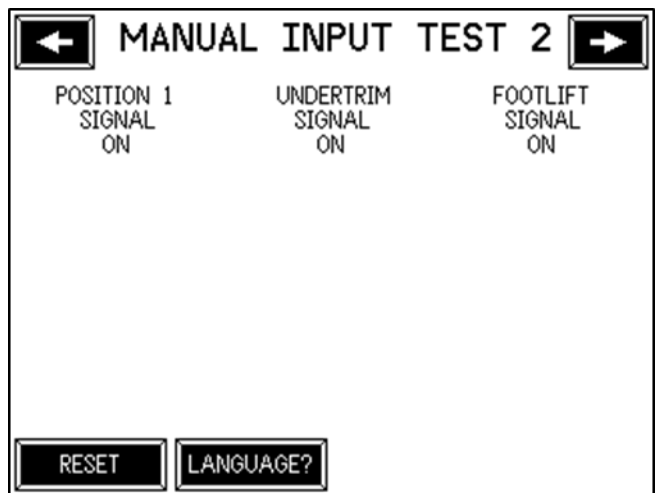

2. MACHINE SETUP

1. Stacker Enable: This setting allows the operator switch the stacker cycle on or off. 0 = off or disabled and 1 = on or enabled.
2. Small rollers enable: Disable the tensioning on the left rollers loading cycle begins within EYE #1 covered
3. System Information: This button takes you to a screen that displays various information about the machine, such as: serial number or software revision number.
4. Security Allows you to change your current level of security or change the password for your security level or any level below you. Appropriate security level required.
5. Style: This bottom access the list of style buttons. Pressing the particular style bottom will allow editing or recalling that style

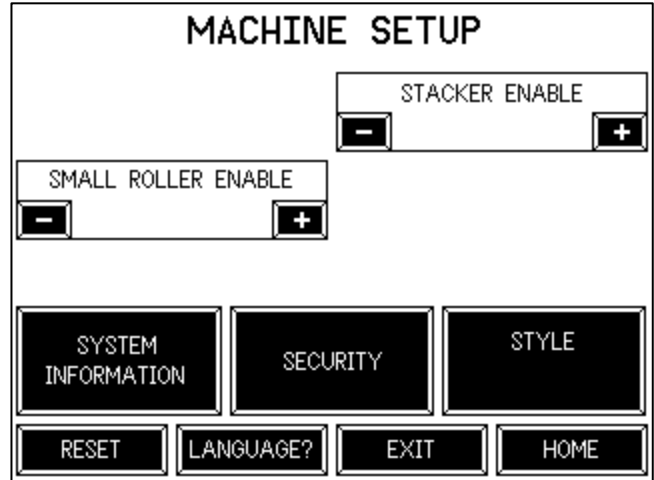

A. SYSTEM INFORMATION

Show combine Data and Program module from the memory module.

Serial number is store on the memory module and software with controller on the program module.

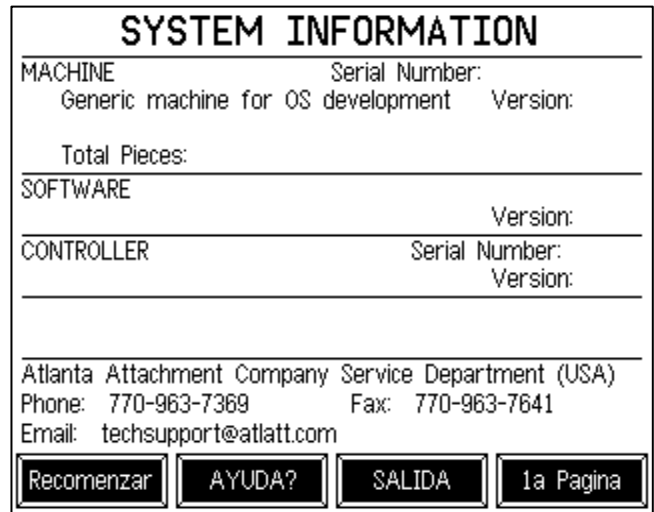

B. STYLE

The STYLE button shows the current style being used. Pressing the STYLE button will take you to the two pages listing the 15 available styles. At the bottom of the page are ADVANCED and RECALL SETTINGS buttons.



Edit the Style

- Press the ADVANCED button.
- The security keypad will appear.
- Enter the mechanic's security code and press ENTER.
- The screen will go back to the STYLE page selected.

- Press EDIT NAMES to change the style name. The name can be a combination of letters, numbers, or symbols including spaces. The page will show the current name in the box with four buttons around it. The buttons to the left and right of the box move the cursor left or right. The buttons on the top and bottom of the box increment or decrement through the alphabet, numbers, and symbols.
- SAVE SETTINGS button will save all of the current parameter settings under that style.
- RECALL SETTINGS will install the last set of parameters saved to that style.
- The advantage to setting up styles is changing the prefeed and over-sew settings depending on the beginning location or size of the shirt is much quicker.



Service Instructions

A. SET UP

Show all Setting. Give access to the Show all settings screen

Advance Set Up give access to the advance set up screen.

Advance setting. Give access to the advance settings Screen

Seam Flip Mode: From this screen the Seam mode can be changed,

Stacker Enable: This setting allows the operator switch the stacker cycle on or off. 0 = off or disabled and 1 = on or enabled

Small Rollers Enable: Disable the tensioning on the left rollers loading cycle begins within EYE #1 covered

System Information: This button takes you to a screen that displays various information about the machine, such as: serial number or software revision number.

Security: Allows you to change your current level of security or change the password for your security level or any level below you. Appropriate security level required.

Advance Manual: Give access to the advance Manual section

Stacker been activated same as the optional small rollers. Give access to the System Information and Security screens

B. SHOW ALL SETTINGS

Shows the current parameter values being used by the machine. It doesn't show the function, only the value. Before any program or module change, take notes of these values or a picture in case of any program issues.

C. ADVANCED SET UP

This button takes you to the Advanced Functions screens. It is only to be use by technicians.

Advanced Setup is an area intended to help the assembler/installer commission (or 'set up') the equipment.

Guide cycle provide continues running to calibrate the Prefeed system.

Stacker Cycle run the stacker in a complete cycle. Machine Cycle; it is used by machine setup at the factory. Only get access to a high level technical password.

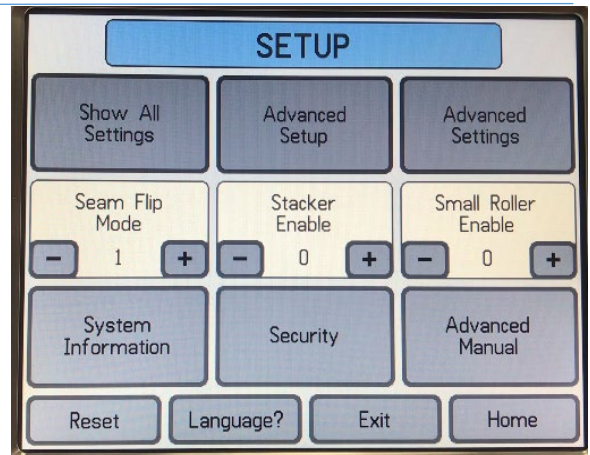

	0	1	2	3	4	5	6	7	8	9
0		10	151	60	48	10	150	15	0	86
10	4	150	10	10	80	25	0	60	—	—
20	50	99	55	—	—	—	—	40	1	0
30	15	50	1	12	—	—	—	1	0	
40										
50										
60										
70										
80										
90										

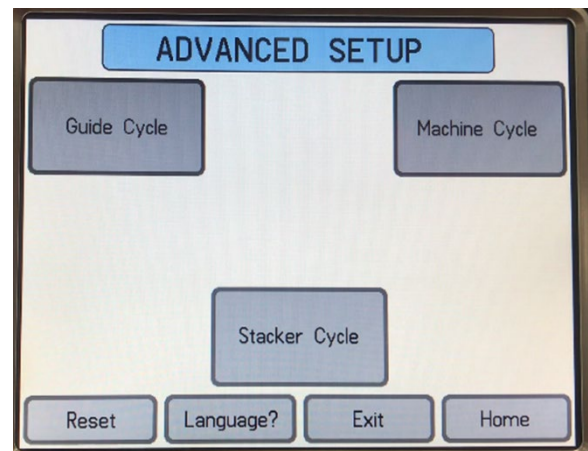

ADVANCED SETTINGS

This button selection gives access to all available settings for the machine..

NOTE: All buttons on Advanced Settings screens 1, 2, 3, and 4 take you to individual setting screens that will allow you to adjust the setting and will give a brief description of how the setting works.

ADVANCED SETTINGS 1

1) Folder Air Jets On Delay:

Note: Only apply to machines with a top guide
Time from folder tongue in until folder air jets turn on. Adjust so air jets come on when the folder is completely engaged.

2) Pre-feed Jog Time:

Jog time of feed rollers until sewing begins. Controls start position of sewing and therefore the position of the over-sew stitches.

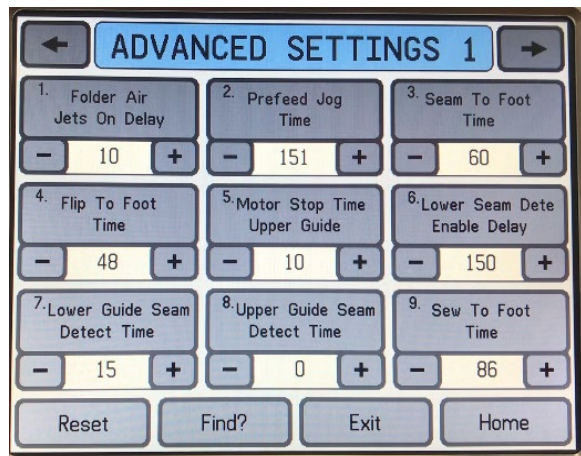

3) Start Feed-In Time Upper Guide Wheel:

Note: Only apply to machines with a top guide
The Feed-in time of upper guide wheel is active until eye #3 in folder goes dark (covers). Should always be set greater than Timer #4 feed-out time. Adjust with timer #4 to gently feed the garment during folder loading. Increasing the number feeds in faster.

4) Start Feed-Out Time Upper Guide Wheel:

Note: Only apply to machines with a top guide
The Feed-out time of upper guide wheel is active until eye #3 in folder goes dark (covers). Should always be set less than Timer #3 feed-in time. Adjust with timer #3 to gently feed the garment during folder loading. Decreasing the number feeds in faster.

5) Guide Motor Stop Time:

Note: Only apply to machines with a top guide
The time the guide motors stop at beginning of sewing to prevent over feeding of upper guide during head acceleration.

6) Lower Seam Detect Enable Delay:

Lower seam detect is disabled for this time after start of sewing to allow guiding to stabilize. Usually set 1/4 to 1/2 of total sewing time.

7) Lower Guide Seam Detect Time:

Time eye#1 must stay light to cause a lower seam detect. Increase if seam detection happens too soon. Decrease if seam detection is missed. Must be set lower than timer #22 JAM DETECT LOWER GUIDE WHEEL.

8) Upper Guide Seam Detect Time:

Note: Only apply to machines with a top guide
Length of time eye #4 must stay light to cause a upper seam detect

9) Finish Feed-In Time Upper Guide Wheel:

Note: Only apply to machines with a top guide

Service Instructions

Feed-in time of upper guide wheel during over-sew, after folder opens. Should always be set greater than Timer #10 feed-out time. Adjust with timer #10 to gently push hem against edge guide during over-sew. Increasing number pushes hem harder.

ADVANCED SETTINGS 2

10) Finish Feed-Out Time Upper Guide Wheel:

Note: Only apply to machines with a top guide
Feed-out time of upper guide wheel during over-sew, after folder opens. Should always be set less than Timer #9 feed-in time. Adjust with timer #9 to gently push hem against edge guide during over-sew. Decreasing number pushes hem harder.

11) Over-sew Length Adjustment:

Sewing time from upper seam detect to end.
Controls the amount of over-sew stitches.

12) End Jog Time:

Time of roller feed after under trimming to pull stitch off of throat plate tongue. Can also be used to index garment to stacking position.

13) Stacker Wipe Start Delay:

Time between left roller retract and stacker wiper on. Adjust to remove tension from garment prior to Stacking.

14) Foot Down Time During Thread Wipe:

Timer that controls foot down time during thread wipe, foot bounce. Also is a part of wiper bar on time.

15) Stacker Wiper Bar On Time:

This timer is used twice. It is the time from stacker wiper bar on during thread wipe. It is also the time from thread wipe foot up until stacker wiper bar off. Adjust so garment is pulled out from under foot by the stacker wiper bar before the foot drops.

16) Stacker Enable:

1-On 0-Off

Turns the stacker on./off.

17) Stitch Condensing Head Stop Time:

Head stop time while stitch condense hardware shifts. Disabled if #18 STITCH CONDENSE TIME = 0.

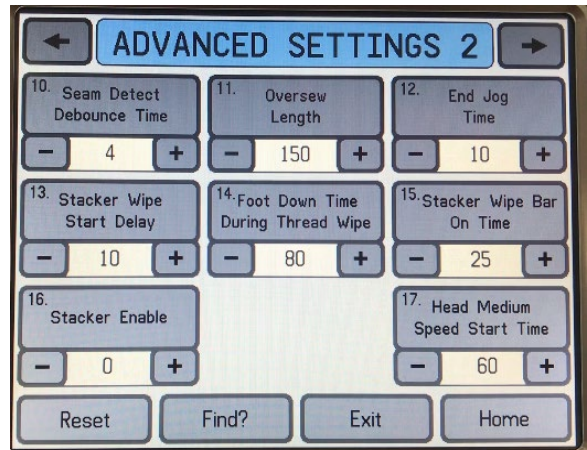

ADVANCED SETTINGS 3

20) Tension Switch Time-out:

Time allowed for tension arm to drop before tension switch is enabled. If this timer times out then the left roller has not expanded and tension is not correct. Should be set as low as possible to activate tension roller without timing out.

21) Thread Break Enable Delay:

Delay time until thread breaks become enabled to allow sewing head to accelerate.

22) Jam Detect Time Lower Guide wheel:

The maximum time eye#1 can remain in one state (light or dark) before jam detection occurs. Must be set greater than #7 LOWER GUIDE SEAM DETECT.

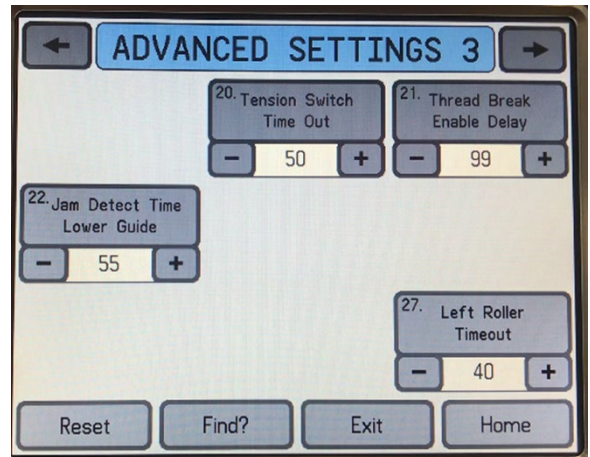

27) Left Roller Time-out:

Length of time allowed for the tension arm to be lifted by the expansion of the left roller. If this timer times out then the left roller has failed to expand and lift the tension arm within the given time.

ADVANCED SETTINGS 4

28) Seam Flip Mode

Select the seam flip Mode There are 4 options

- Disable: For tubular shirts without side seam,
- Guide Enable: Machine recognize the side seam
- Seam Detector and Seam flip. Same as before but Activate the seam flip device
- Flat seam with seam flip and seam detector. Same as before but machine do a couple of front and back movement to realign the material.

29) Small Roller Enable

0= Disable- left roller will expand as normal

1= Enable- Left roller will not expand

When Enable left roller must be manually set to correct position before the shirt is loaded

30) Stacker Delay

Set a delay on the stacker to load the shirt

31) Air Pressure Low Limit

Show the limited air pressure before the unit show low pressure error.

32) Piece Count Mode

Method of counting the pieces

33) Bundle Size

Select the limit of pieces by bundle

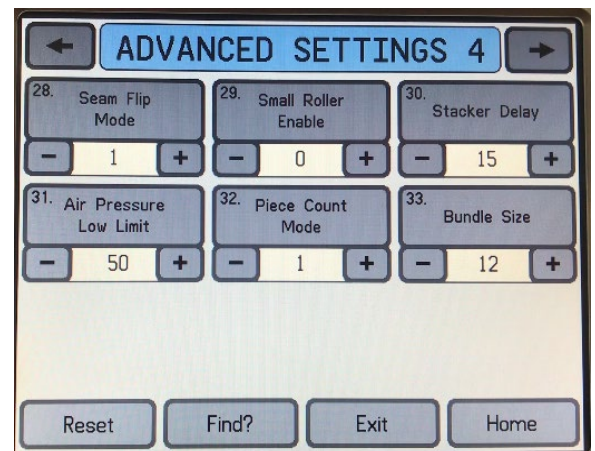

Service Instructions

D. SYSTEM INFORMATION

Show combine Data and Program module from the memory module.

Serial number is store on the memory module and software with controller on the program module.

ADVANCE MANUAL 1

There are 3 screen for Advance manual.

A Gray rectangle on the Advance Manual Screen belong to an output. Output rectangles are buttons that manually activate that particular device or cycle Will allow the manual activation of the cylinders, solenoids, and motors.

A white rectangle on the Advance Manual Screen belong to an impute signal;

A double line below the name of an input device is used to denote a change in its state. When an eye is covered, a change in state will be shown on the screen.

An example is when you manually cover the RAW EYE #1 a rectangle appears around the name RAW EYE. The eyes, foot pedals, and proximity switches can be checked.

While testing input devices the machine WILL NOT start in automatic mode.

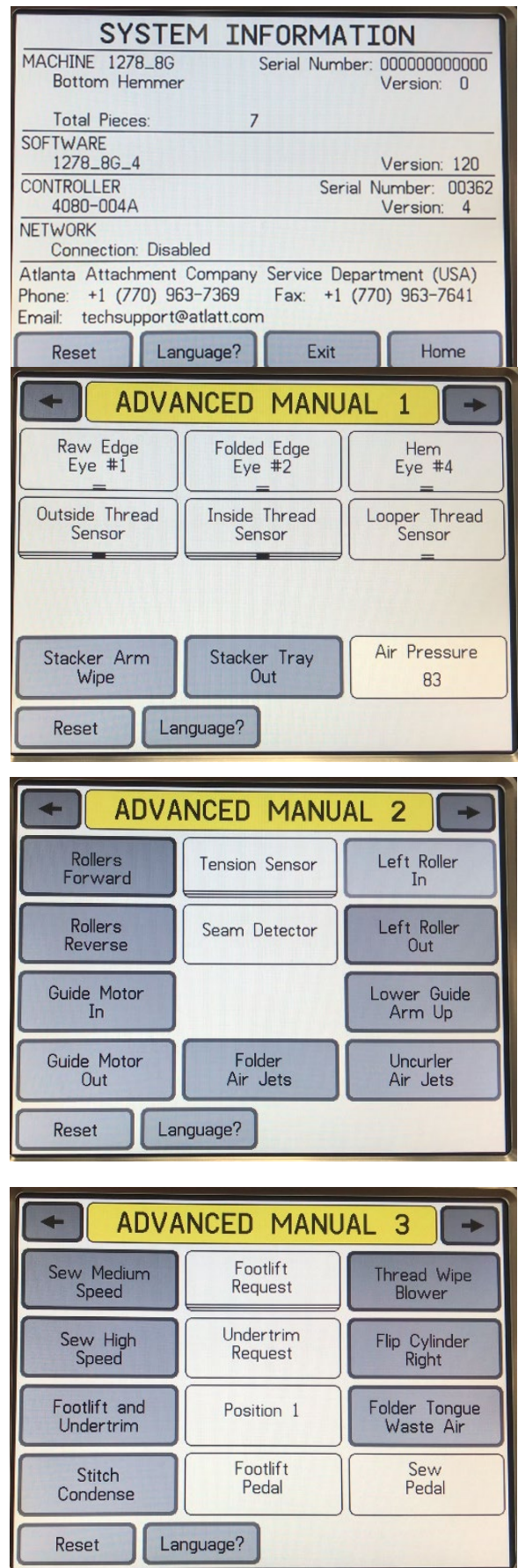

Service Instructions

Expiration Count 911

Expiration Count Code "911" is not an error that can be resolved without assistance from Atlanta Attachment.

- Machine has displayed this error as the result of someone removing or installing modules incorrectly.
- Machine has completed a predetermined time-cycle set by the factory.

When contacting Atlanta Attachment via phone or e-mail, please provide this information below, as displayed on the "911" screen

- The machine type
- The machine serial number
- The security key
- The master clock

Here is what the 911 warning currently says:

Warning 911 Instructions

1. Contact the Atlanta Attachment Company Service Department (USA).

Phone: +1 (770) 963-7369

Fax: +1 (770) 963-7641

Email: techsupport@atlatt.com

2. Once in contact, provide the following information.

000 Machine Type
000000000000 Machine Serial Number
00000 Security Key
0000000000 Master Clock

To TEMPORARILY bypass this warning, press CONTINUE

1. Unlock Procedure

1. Power up the machine while pressing the center of the screen with your finger.
2. Once the screen becomes white, remove your finger and two lines should appear crossing in the upper left corner of the screen.
3. Calibrate the touch screen by pressing where the lines cross with the tip of your finger.
4. Two other lines should appear crossing in the lower right corner of the screen.
5. Calibrate the touch screen by pressing where the lines cross with the tip of your finger.

6. A language selection menu should now appear.

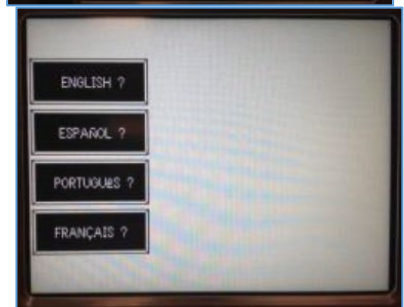
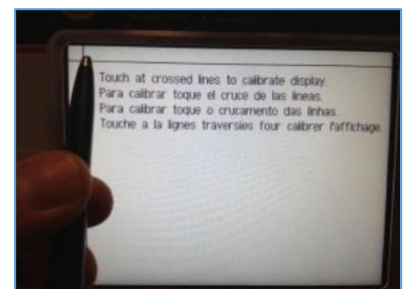

7. A MECHANIC SECURITY SCREEN should appear. Type your 5 digit security code



8. The Controller Setup show up; press continue



9. In the screen CONFIG UTILITIES, press EXP CODE.

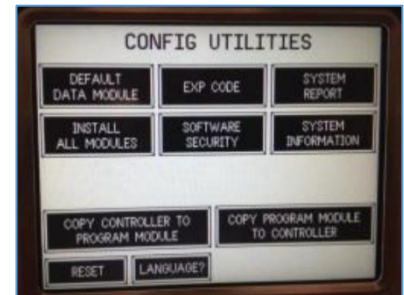

10. Report the three numbers at the top to the AAC Service department staff.

- A. The machine type
- B. The machine serial number
- C. The security key

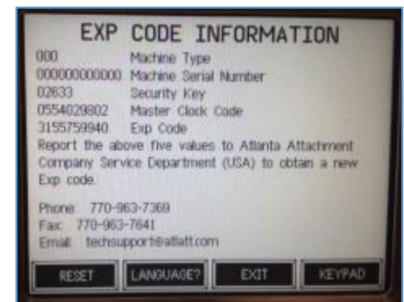

11. The AAC Service department staff will provide you with the new EXP CODE value.

12. To enter it, press the KEYPAD button at the bottom right of the screen.

13. Enter in the new EXP CODE value using then left and right buttons to position the cursor where desired. Use the Increment and Decrement buttons above and below to adjust the value under the cursor. When the 15 digit number is correct, Press Enter.

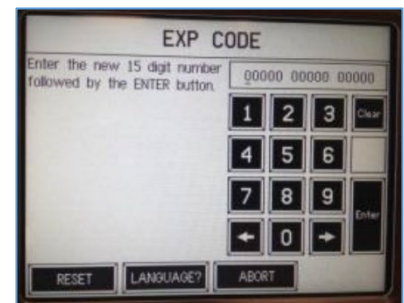

14. Press RESET to reboot the machine.

3.6. Maintenance

NOTE: Always wear proper safety equipment when operating or performing maintenance on any equipment.

It is important that the machine operator read this manual and is familiar with all the functions and safety concerns of the unit before operating.

3.6.1. General Safety Instructions

Maintenance should only be performed by trained, qualified personnel. Before performing any maintenance or repair work, switch off the electrical, pneumatic, etc. power to the machine at the main source and secure it with a padlock so that it cannot be switched on again without authorization. Refer to lockout/tag out procedures

- Always wear proper safety equipment when operating or performing maintenance on any equipment.
- All recommended maintenance is for a single shift schedule; adjust as necessary for a multi-shift operation.
- Equipment should not be used for purposes other than designed or specified.
- The machine shall be switched off, come to a standstill and be secured so that it cannot be switched on again inadvertently before starting any maintenance work whatsoever.
- Use proper lockout/tag out procedures to secure the machine against inadvertent startup.
- Remove any oil, grease, dirt and waste from the machine, particularly from the connections and screws, when starting the maintenance and/or repair work.
- Do not use any corrosive-cleaning agents.
- Use lint-free rags.
- Retighten all screw connections that have to be loosened for the maintenance and repair work.
- Any safety mechanisms that have to be dismantled for setting-up, maintenance or repair purposes must be refitted and checked immediately after completing the work



Preventive Maintenance 40 Hrs

Model:	12788	Required Materials
Serial #:		
Operation:	Bottom Hemming	
Sew Head:		
Serial #:		
Needle:	SNUY128GAS-12 80	Oilcan Oil for sewing machine Clean cloth Compressed air

.- Open covers, remove needle plate. With an air gun blow the machine out and remove accumulated dirt in hard to reach areas

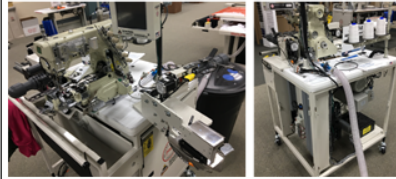

Check Sharpness of edge trimming knives and sharpen if required



Check all reflecting tape for wear and replace if required. If tape is replaced readjust eye sensors



Check all air cylinders for correct activation speed. Adjust flow control if required. Check pressure regulator and adjust. Main 80 psi, Tension cylinder 10-20 psi, Guide wheel pressure 20-25 psi

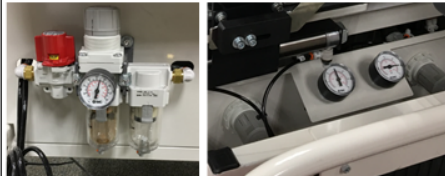

Check all mechanical assembly. Tighten loosen components if found. Check Tension arm for free movement. (Turn air pressure of and move by hand)



Check tension of all stepping motor belts and sewing motor v-belt and adjust if necessary

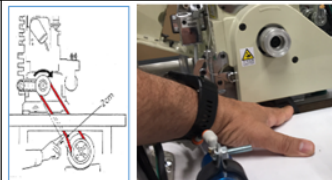

Check wear and free rotation of o rings on edge guide roller and replace if required. Check guide wheel engagement. Make sure it contact plate when actuated



.- Perform Daily Maintenance



Preventive Maintenance 960 Hrs

Model: 12788	Required Materials
Serial #:	
Operation: Bottom Hemming	
Sew Head:	
Serial #:	
Needle: SNUY128GAS-12 80	

Remove the oil plug and empty the oil in the machine. Replace Oil and change oil filter



Check filter elements in air regulator and replace if necessary



Inspect pillow blocks and other non-sealed bearings (conveyors and rotating shafts) and apply one shot of recommended grease to each bearing/fitting.



Open or remove doors and/or covers and inspect belt(s) for debris or wear and clean or replace as necessary.



Review Roller Rings (A) for conditions. They need to be flexible and do not have a slippery surface

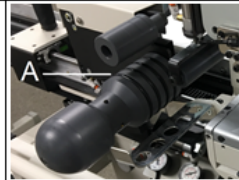

.- Perform Weekly Maintenance

3.7. Troubleshooting

3.7.1. Screen Messages

Error	Cause:	Corrective action:
<p>#1 #2 #3, Needle Thread Break Failure</p> <p>Indicated by machine stopping and message on screen.</p> <div data-bbox="111 583 466 852" style="border: 1px solid black; padding: 5px;"> <p style="text-align: center;">MACHINE ERROR #1</p> <hr/> <p>Error #1 Thread break on outside needle.</p> <p>Possible Solutions: 1. Check thread and replace if broken. 2. Make sure thread is routed properly through sensor. 3. Replace or re-program sensor.</p> <p style="text-align: center;"> <input type="button" value="RESET"/> <input type="button" value="CONTINUE"/> </p> </div>	<ol style="list-style-type: none"> 1. Thread tangled in eyelets. 2. Bad needle. 3. Sewing head misadjusted. 4. Thread break detectors misadjusted or defective. 	<ol style="list-style-type: none"> 1. Check the thread and replace if broken. 2. Make sure that the thread is routed properly through sensor. 3. Adjust tension on sensor. 4. Replace or re-program sensor 5. Replace Needle
<p>#4 Lopper Thread Break Failure</p> <p>Indicated by machine stopping and message on screen</p> <div data-bbox="111 1144 466 1414" style="border: 1px solid black; padding: 5px;"> <p style="text-align: center;">MACHINE ERROR #4</p> <hr/> <p>Error #4 Thread break on looper.</p> <p>Possible Solutions: 1. Check thread and replace if broken. 2. Make sure thread is routed properly through sensor. 3. Adjust Sensitivity of sensor (Light goes off as thread moves through it. 4. Replace sensor.</p> <p style="text-align: center;"> <input type="button" value="RESET"/> <input type="button" value="CONTINUE"/> </p> </div>	<ol style="list-style-type: none"> 1. Thread tangled in eyelets. 2. Sewing head misadjusted. 3. Thread break detectors misadjusted or defective. 4. Lopper take off pulling too much thread 	<ol style="list-style-type: none"> 1. Check the threading of the machine, needles, tension setting, etc. 2. Make sure that the threads makes good contact with thread break detector eyelets. 3. Adjust the sensitivity of thread break detectors. If no threads are broken, check for skipped stitches in the area where the machine stopped. If no threads were broken or stitches skipped, then decrease the sensitivity of the detectors. To decrease the sensitivity of the detectors, turn the sensitivity screw clockwise. 4. Restart the machine by pressing CONTINUE or press RESET and remove the garment. 5. Retard looper thread take off a little by losing set screws rotating take off dishes back

Service Instructions

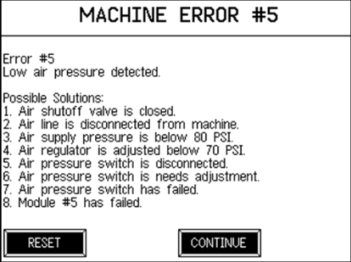
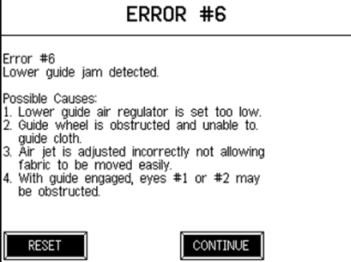
Error	Cause:	Corrective action:
<p>#5 Low Air Pressure Detected</p>  <p>The screenshot shows a message box titled "MACHINE ERROR #5". The text reads: "Error #5 Low air pressure detected. Possible Solutions: 1. Air shutoff valve is closed. 2. Air line is disconnected from machine. 3. Air supply pressure is below 80 PSI. 4. Air regulator is adjusted below 70 PSI. 5. Air pressure switch is disconnected. 6. Air pressure switch needs adjustment. 7. Air pressure switch has failed. 8. Module #5 has failed." At the bottom are "RESET" and "CONTINUE" buttons.</p>	<ol style="list-style-type: none"> 1. Air shutoff valve is closed 2. Airline is disconnected form machine 3. Air supply pressure is below 80 PSI 4. Air regulator is adjusted below 80 PSI 5. Air pressure switch is disconnected 6. Air pressure switch need adjustment 7. Air pressure switch failed 8. Module 5 has failed 9. 	<ol style="list-style-type: none"> 1. Open air valve 2. Connect air line 4. Verify air compressor is running 5. Readjust air pressure regulator to 80 PSI 6. Review air pressure switch connection 7. Replace air switch 8. Replace module 5 9.- Verify that there are no restrictions on the airline that are producing air drops
<p># 6 Lower Guide Jam Detected</p> <p>Message on the screen and the machine stopping.</p>  <p>The screenshot shows a message box titled "ERROR #6". The text reads: "Error #6 Lower guide jam detected. Possible Causes: 1. Lower guide air regulator is set too low. 2. Guide wheel is obstructed and unable to guide cloth. 3. Air jet is adjusted incorrectly not allowing fabric to be moved easily. 4. With guide engaged, eyes #1 or #2 may be obstructed." At the bottom are "RESET" and "CONTINUE" buttons.</p>	<ol style="list-style-type: none"> 1. Lower guide uncurl air jets not uncurling the fabric edge making control difficult. 2. Improper guide pressure. 3. Too much tension on body of garment making it difficult for guides to control fabric. 4. Setting #22 set too low. 5. Drive belt too tight 	<ol style="list-style-type: none"> 1. Adjust the lower uncurled jets; they should have the correct position and flow to hold the garment edge flat in the area where the eye is looking. In order for eye number one to effectively guide the cloth, it must look at a flat, uncurled edge. 2. Check pressure on the lower guide wheels. Make sure that the individual wheels spin freely on their own axles. Heavier weight fabric may need more pressure. Lighter weight fabric may need less. Look carefully at the flow of the cloth through the guide wheel. If the pressure is set too high, the fabric will bunch up directly in front of the guide wheels. If the pressure is not enough, the wheels will spin without moving the fabric. 3. Restart the machine by pressing the continue button or press RESET and remove the garment. 4. Increase #22 if set lower than default value. 5. Loosen motor mount screws. Set guide wheel to plate, but should not be very tight, Tighten motor mount screws

Service Instructions

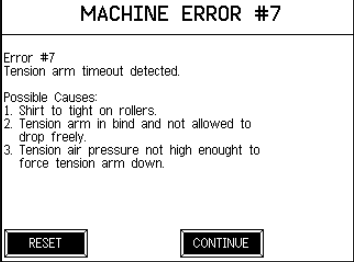
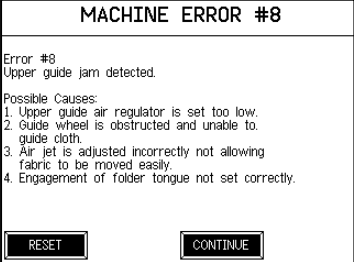
Error	Cause:	Corrective action:
<p>#7 Tension Arm Time Out Detected</p> 	<p>In normal operation, when a shirt is loaded, the tension arm drops and uncovers a prox switch. As the left roller moves to the left, the shirt raises the tension arm as it gets tighter. The tensioning stops when the prox switch is covered. The tension arm error can occur if the prox switch never uncovers, or if the prox switch doesn't get covered again. If the tensioning pressure is set too high and the shirt doesn't have sufficient body to pull the arm up, the error will occur.</p>	<p>The counterweight on the end of the arm should be set so that the arm is balanced with the air supply to the machine turned off. When the air is turned on, the air pressure on the tension arm is the load the shirt tension has to overcome to move the arm.</p> <p>If the operator has the left roller positioned so that the shirt is stretched onto the rollers to load, the arm won't drop far enough to uncover the prox switch, and the error will appear.</p> <p>If the operator has the left roller positioned so that the shirt is loose on the rollers after the roller has moved to the left, the arm won't lift high enough to cover the prox switch.</p> <p>If the left roller movement cylinder flow control isn't adjusted correctly, the cylinder could reach its limit before the tension arm uncovers the prox switch.</p> <p>If the target on the tension arm that covers the prox switch is set too high, the switch may not uncover and the error will appear.</p>
<p>#8 Upper Guide Jam detected</p> <p>Indicated by message on the screen and the machine stops.</p> 	<ol style="list-style-type: none"> 1. Lower guide not set to give upper guide enough fabric to hem properly. Guide trying to push the fabric into the folder. 2. Improper guide pressure. 3. Setting #23 set too low. 4. Drive belt to tight 	<ol style="list-style-type: none"> 1. Adjust the lower guide eye so that the lower guide will give the folder more fabric. The general direction of the top guide wheel should be pulling fabric out of the folder at a slow rate. If the folder is not getting enough fabric from the lower guide, then the top guide will try to push more fabric into the folder to compensate. It is very difficult for the guide to push the fabric into the folder and may result in an upper guide failure or pleating of the hem. 2. Check pressure on the upper guide wheels. Make sure that the individual wheels spin freely on their own axles. Heavier weight fabric may need more pressure. Lighter weight fabric may need less. Look carefully at the flow of the cloth through the guide wheel. If the pressure is set too high, the fabric will bunch up directly in front of the guide wheels. If the pressure is not enough, the wheels will spin without moving the fabric. 3. Increase Setting #23 if set less than default value. 4. Loosen motor mount screws Set guide wheel to plate, bur should not be very tight, Tighten motor mount screws

Service Instructions

Error	Cause:	Corrective action:
<p>#9 Folder Load Fault</p> <div data-bbox="113 256 462 521" style="border: 1px solid black; padding: 5px;"> <p style="text-align: center;">MACHINE ERROR #9</p> <p>Error #9 Folder load fault</p> <p>Possible Causes: 1. During the jog cycle eye #3 was never covered indicating that the folder was never sufficiently loaded. 2. Pre-jog time is to short.</p> <p style="text-align: center;"> <input type="button" value="RESET"/> <input type="button" value="CONTINUE"/> </p> </div>	<ol style="list-style-type: none"> 1. During the Jog Cycle eye #3 was never covered indicating that the folder was never sufficiently loaded 2. Pre-jog time is to short 	<p>The folder load fault applies to the upper guide unit. The top guide wheel needs to make contact with the plate to control the material. If the drive belt is too tight, the wheel won't make contact with the plate when the arm is sent down.</p> <p>Parameters 3 & 4 control the guide wheel feed time in the in and out directions until eye # 3 is covered.</p> <p>Parameter 3 controls the length of time the wheel moves the material into the folder.</p> <p>Parameter 4 controls the speed moving the material out of the folder. Increasing the parameters increases the length of time the wheel moves in the particular direction.</p> <p>The higher the setting, the less the material moves in and out.</p>

3.7.2. Seam

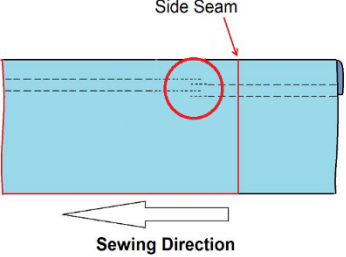
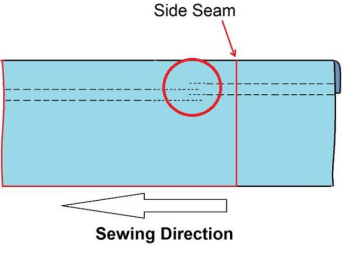
Problem	Cause:	Corrective action:
<p>The fabric between the foot and the left roller become stretched during sewing causing the hem to pucker.</p>	<p>If the feed rollers are feeding at a faster rate than the feed dogs, the fabric will pull away from the edge guide at the foot when the folder tongue retracts.</p>	<p>Reduce Speed of the rollers</p>
<p>Stitch and over-sew misalignment. Narrow hem at the seam end</p> 	<p>Shirring can also contribute to alignment problems.</p> <p>Eye #2 is adjusted too far out towards the operator.</p> <p>Excess material under the foot at the start of the hem.</p> <p>If the feed rollers are feeding at a faster rate than the feed dogs, the fabric will pull away from the edge guide at the foot when the folder tongue retracts.</p>	<p>Be sure that all shirring is eliminated from the feed dogs.</p> <p>Adjust Eye according</p> <p>Air jet 12A in front of the foot is blowing too hard or down into the edge guide.</p> <p>Reduce Speed of the rollers</p>
<p>Stitch and over-sew misalignment. Wider hem at the seam end</p> 	<p>Eye #2 is adjusted too far in and pushing the material against the edge guide.</p> <p>If the feed rollers are feeding at a slower rate than the feed dogs, the fabric will be loose between the presser roller and the presser foot. The fabric will appear to bunch up behind the presser foot.</p>	<p>Adjust Eye according</p> <p>Increase Speed of the rollers</p>

3.7.3. Electrically

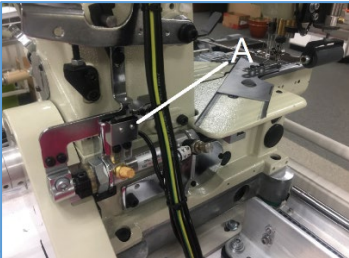
Problem	Cause:	Corrective action:
<p>Machine do not turn ON</p>	<p>No Power</p>	<ul style="list-style-type: none"> • Check the green button on the lock out switch inside the right door of the machine. If it is not pressed in and lit, press the green button. • If it doesn't light up when pressed, check the voltage at the top of the contactor. If there is no voltage, check the breaker at the electrical box. • Use the wiring diagram for your machine loaded in the parts manual to check the voltages.
<p>Shirt falling</p>	<p>Large O-rings located on the guide rollers should be replaced on the average of every 6 months or more frequently if they become hard and slick. They will naturally harden due to climate, heat and dust.</p> <p>The softness and sticky surface of new O-ring's has a greater ability to hold the shirt from falling off the rollers with less air pressure used to extend the left roller</p>	<p>Replace 3 O-rings</p>
<p>Do not start sewing</p> 	<p>Knife switch not activated</p>	<p>Review switch</p>

Service Instructions

--	--	--

Service Instructions

3.7.4. Efka Controller Error

General Information			
On the control	On the V810	On the V820	Signification
A1	InF A1	InF A1	Pedal not in neutral position, when turning the machine on
A2	-StoP- blinking	-StoP- blinking + symbol display	Machine run blockage
A3	InF A3	InF A3	Reference position is not set
A6	InF A6	InF A6	Light barrier monitoring
A7	Symbol blinking	Symbol blinking	Bobbin thread monitor

Programming Functions and Values (Parameters)			
On the control	On the V810	On the V820	Signification
Returns to 000 or to last parameter number	Returns to 0000 or to last parameter number	Like V810 + display InFo F1	Wrong code number or parameter number input

Serious Condition			
On the control	On the V810	On the V820	Signification
E1	InF E1	InF E1	The external pulse encoder e.g. IPG... is defective or not connected.
E2	InF E2	InF E2	Line voltage too low, or time between power off and power on too short.
E3	InF E3	InF E3	Machine blocked or does not reach the desired speed.
E4	InF E4	InF E4	Control disturbed by deficient grounding or loose contact.
E9	InF E9	InF E9	EEPROM defective.

Hardware Disturbance			
On the control	On the V810	On the V820	Signification
H1	InF H1	InF H1	Commutation transmitter cord or frequency converter disturbed.
H2	InF H2	InF H2	Processor disturbed

1. Flow Chart EFKA Error E1

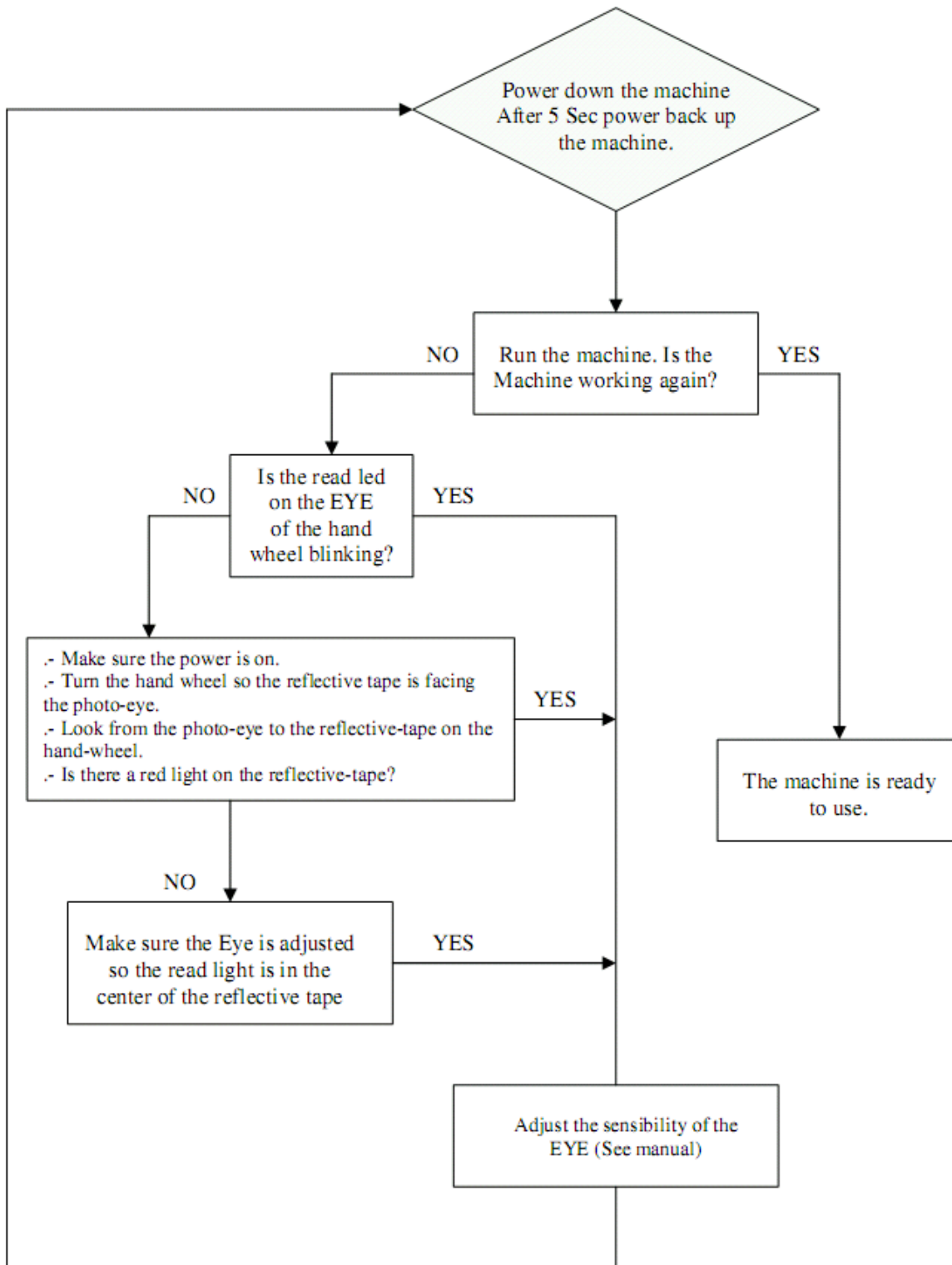

3.7.5. Panasonic D9 Controller Errors

• Information Error Code and Measurement:

Error Code	Abnormality Item	Cause of The Problem	Measure
E - 1	•Sewing machine lock	<ul style="list-style-type: none"> • Sewing machine lock • Needle sensor connector is disconnected •V-Belt has loose tension • Motor connector is disconnected • Trimmer sequence is set improperly 	<ul style="list-style-type: none"> •Check the sewing machine •Connect the needle sensor connector •Tighten the belt(See page 4) •Connect the motor connector •Confirm trimmer sequence
E - 2	•Hardware tripping in control	<ul style="list-style-type: none"> • Abnormal power supply voltage for control box •High voltage at braking form high speed 	<ul style="list-style-type: none"> •Check the power-supply voltage •Replace the control box to repair the regenerated circuit
E - 3	•Encoder signal of motor sensor is abnormal	<ul style="list-style-type: none"> • Motor connector is disconnected 	<ul style="list-style-type: none"> •Connect the motor connector •Check the wires of the motor sensor cable
E - 4	• Commutation signal of motor sensor is abnormal	<ul style="list-style-type: none"> • Motor connector is disconnected 	<ul style="list-style-type: none"> •Connect the motor connector • Check the wires of the motor sensor cable •Replace the motor
E - 5	•Abnormal motor speed	<ul style="list-style-type: none"> • Abnormal control box 	<ul style="list-style-type: none"> •Replace the control box
E - 6	•Motor over-load or lock	<ul style="list-style-type: none"> •Machine has heavy load •Motor connector is disconnected 	<ul style="list-style-type: none"> •Check the machine load. If yes, reduce the machine load. •Connect the motor connector.
E - 7	• High voltage supply	<ul style="list-style-type: none"> • Power supply voltage abnormal 	<ul style="list-style-type: none"> • Exchange control Box
E - 8	•Abnormal Solenoid.	<ul style="list-style-type: none"> •Solenoid is short-circuited 	<ul style="list-style-type: none"> •Check the solenoid.
E - 10	• Control Box memory is abnormal.	<ul style="list-style-type: none"> • EEPROM has wrong data. 	<ul style="list-style-type: none"> • Reset EEPROM by using (RESET) node.

E - 11	•Abnormal Communication	<ul style="list-style-type: none"> •The console is cable was plugged in after power on. 	<ul style="list-style-type: none"> • Plug in the console cable with power off, then power on.
SAFE	Safety Switch	<ul style="list-style-type: none"> Trimming protection Safety switch broken Safety switch setting incorrect (open or close) 	<ul style="list-style-type: none"> Correct trimming device to be used Check if the switch is damaged Usually set to close, use A14 to adjust.

Atlanta Attachment Company (AAC)

Statement of Warranty

Manufactured Products

Atlanta Attachment Company warrants manufactured products to be free from defects in material and workmanship for a period of eight hundred (800) hours of operation or one hundred (100) days whichever comes first. Atlanta Attachment Company warrants all electrical components of the Serial Bus System to be free from defects in material or workmanship for a period of thirty six (36) months.

Terms and Conditions:

AAC Limited Warranty becomes effective on the date of shipment.

AAC Warranty claims may be made by telephone, letter, fax or e-mail. All verbal claims must be con-firmed in writing.

AAC reserves the right to require the return of all claimed defective parts with a completed warranty claim form.

AAC will, at its option, repair or replace the defective machine and parts upon return to AAC.

AAC reserves the right to make the final decision on all warranty coverage questions.

AAC warranty periods as stated are for eight hundred (800) hours or one hundred (100) days whichever comes first.

AAC guarantees satisfactory operation of the machines on the basis of generally accepted industry standards, contingent upon proper application, installation and maintenance.

AAC Limited Warranty may not be changed or modified and is not subject to any other warranty expressed or implied by any other agent, dealer, or distributor unless approved in writing by AAC in advance of any claim being filed.

What Is Covered

Electrical components that are not included within the Serial Bus System that fail due to defects in material or workmanship, which are manufactured by AAC are covered for a period of eight hundred (800) hours.

Mechanical parts or components that fail due to defects in material or workmanship, which are manufactured by AAC.

Purchased items (sewing heads, motors, etc.) will be covered by the manufacturers (OEM) warranty.

AAC will assist in the procurement and handling of the manufacturers (OEM) claim.

What Is Not Covered

Parts that fail due to improper usage, lack of proper maintenance, lubrication and/or modification.

Damages caused by; improper freight handling, accidents, fire and issues resulting from unauthorized service and/or personnel, improper electrical, plumbing connections.

Normal wear of machine and parts such as Conveyor belts, "O" rings, gauge parts, cutters, needles, etc.

Machine adjustments related to sewing applications and/or general machine operation.

Charges for field service.

Loss of time, potential revenue, and/or profits.

Personal injury and/or property damage resulting from the operation of this equipment.

TRAINING

Check	Description	Time Hrs.
	Basic Function - Review Of Machine <ul style="list-style-type: none"> • Sequence of operation • Manual And Automatic Operation For Technicians 	2
	Discuss Operation Of Drive System <ul style="list-style-type: none"> • Puller drive system, stepping motor controller. • Left roller drive system, stepping motor controller. • Right roller drive system, stepping motor controller. • Adjustments and functions of each. • Setting of jog feature of each. • Power connections and AMP settings of each. 	3
	Electric eyes: Edge Guiding <ul style="list-style-type: none"> • Discuss the ease of setting the eyes in correct position. • Easy removal of eyes. • Set gain on electric eyes. • Maintenance of reflective tape. 	1.5
	Sewing Heads of Each Unit – Maintenance <ul style="list-style-type: none"> • Basic function. • Oil and filter change intervals. • Timing and adjustments. • Recommended speeds for different threads. 	4
	Hemmer Sewing Head <ul style="list-style-type: none"> • Footlift/head lift switch. • Air electric switch in conjunction with footlift. • Chain cutter assembly basic function. • Maintenance of chain trimmer. • Proper adjustments of knife blades. • Setting of chain trimmer to sewing head. 	2
	Waste System Assembly Function and Operation <ul style="list-style-type: none"> • Disassemble vacuum assembly; adjust for proper air volume; set to proper PSI (80 psi.). • Discuss how to perform preventative maintenance. • Proper tube connection. 	1
	Edge Trimming Knife <ul style="list-style-type: none"> • Knife adjustment, disassembly and adjustments. • Proper setting and changing blades. • Height of assembly to folder. 	1
	Folder on Hemmer <ul style="list-style-type: none"> • Basic function. • Mechanical breakdown adjustment 	1



	<ul style="list-style-type: none">• Alignment procedure.• Adjust hem size procedure.	
	Thread Detectors Hemmer and Seamer <ul style="list-style-type: none">• Proper alignment.• Adjust sensitivity.• Operation procedure	0.5
	Stacker <ul style="list-style-type: none">• Basic operation.• Adjustment of door and tray alignment.	1
	Sew Off Machine <ul style="list-style-type: none">• Start review of any questions thus far.	1
	Electrical and Pneumatics <ul style="list-style-type: none">• Diagram evaluation.• Discuss on-board programming of new AAC logic control	4
	Troubleshoot Unit	1
	Basic Function - Review Of Machine with Operator <ul style="list-style-type: none">• Sequence of operation• Operator instruction and breakdown• Manual And Automatic Operation For Operator	2
	Evaluate any questions.	1

Participants:

Instructor: _____

Date: _____



Notes:

Add more troubleshooting

Ask Frank about auto cycle

Review thread trimming switch



INDEX

A

ADVANCED FUNCTIONS, 53
ADVANCED SETTINGS, 53, 54, 55,
56, 57
Air Filters, 33
Air Pressure Switch, 34
Air Supply, 12
AUTOMATIC, 19

B

Blowers, 36

C

Calibration, 49
Changing Seam Margin, 30
Changing Stitch Length, 30
CLOCK, 18
Contents, 1
Control Panel, 15
Cutting Margin, 29
CW/CCW jumpers, 44

E

Edit the Style, 60
Efka, 17, 46, 57, 73
Electric Eyes, 12, 39
Electrical, 0, 3, 5, 26, 38, 51, 76,
78
Electrically, 51, 71
Emergency Stop, 12, 15, 18
EXP CODE, 62
Expiration Count 911, 61
Eye Sensor Adjustment, 40

F

First Aid, 2
Folded Edge Eye, 39
Folder Flag, 31
Folder Load Fault, 69
Folder Settings, 31
Foot print, 10
Footlift Pedal, 12, 15

G

Ground, 38

H

Hem Detect Eye, 39

I

Inner Uncurl jets, 36
INSTALLATION, 7

J

JOG button, 44, 45
Jumpers, 44

L

Left Roller, 15, 27, 42, 57
Left Roller Assembly, 15
Lockout/Tagout Program, 26
Lopper Thread Sensor, 41
Low Air Pressure, 67
Lower Edge Guide, 42, 44
Lower Guide Jam, 67
Lower Guiding, 16

M

Machine Classes, 8
MACHINE DIAGNOSTICS, 57
MACHINE SETUP, 59
Main Circuit Breaker, 38
Main Power Contactor, 38
Maintenance, 5, 24, 26, 33, 40,
63, 77
MANUAL INPUT, 58
MANUAL OUTPUT TEST, 57, 58
MANUAL SEWING, 21
MECHANIC SECURITY SCREEN, 62
Modules, 51

N

Needle Thread Sensor, 41

O

Oil, 11, 77
OPERATION, 14
OPERATOR OUTPUTS, 21
Options & Classes, 9
Outer Uncurl Jets, 36

Over sew, 29
OVERSEW, 19

P

Panasonic, 17, 47, 48, 75
Panasonic Motor, 47
Parts and Components, 7
[Patents & Patents Pending](#), 0
PIECE COUNTER, 19
Pneumatic, 0, 3, 6, 26, 33, 47
Potentiometer, 44
Power Connection, 12
PREFEED TIME, 19
Presser Foot, 28
Presser Roller, 16
Pressure Regulator, 33
Pressure Relief, 33
Production, 8
Program Update, 52

R

RESET, 13, 18, 19, 21, 50, 62, 66,
67
Right Roller, 16, 27, 42
Roller set up, 27
Rollers Motors, 42

S

Safety Instruction, 0
Screen Error Messages, 66
Seam, 29, 30, 32, 54, 55, 70
Seam Begging, 29
Seam Detection, 32
Seam Margin, 29
SEMI-AUTOMATIC, 20
Serial Bus, 11, 15, 49, 76
Serial Number, 10
SERVICE, 26
Sewing Head, 8, 13, 77
Sewing Head Lubrication, 11
Sewing Motor, 17
SHOW ALL SETTINGS, 53
SINGLE STEP, 20
Single Step Mode, 20
Solenoid Valve, 33
Stacker, 11
Start Sew Pedal, 15
Statement of Warranty, 76
STATISTIC, 60

ATLANTA ATTACHMENT COMPANY 362 INDUSTRIAL PARK DRIVE, LAWRENCEVILLE, GA 30046 E-MAIL:
SALES@ATLATT.COM PHONE: +1 (770) 9637369



Stepping Motors, 12, 17, 42
STYLE, 59, 60
SYSTEM INFORMATION, 59

T

Technical Data, 8
Technical Screens, 53
Tension Arm Time Out, 68
Tension Roller, 28
Tension Sensor Switch, 40

Thread Break Detectors, 41
Thread Break Failure, 66
Thumbwheels, 44
Touch-Screen, 18
Troubleshooting, 66

U

Update Controller, 52
Upper Guide, 32, 39, 54, 55, 56,
68

Upper Guiding, 16

V

V-belt, 10

W

Waste System, 11, 17, 77
Waste Venturi, 34



Atlanta Attachment Company Inc.
362 Industrial Park Drive
Lawrenceville, GA 30046
Phone: +1 (770) 963-7369
www.atlatt.com

Printed in USA
Digital Version of this Manual Available at:
http://atlatt.com/tech_manuals.php