

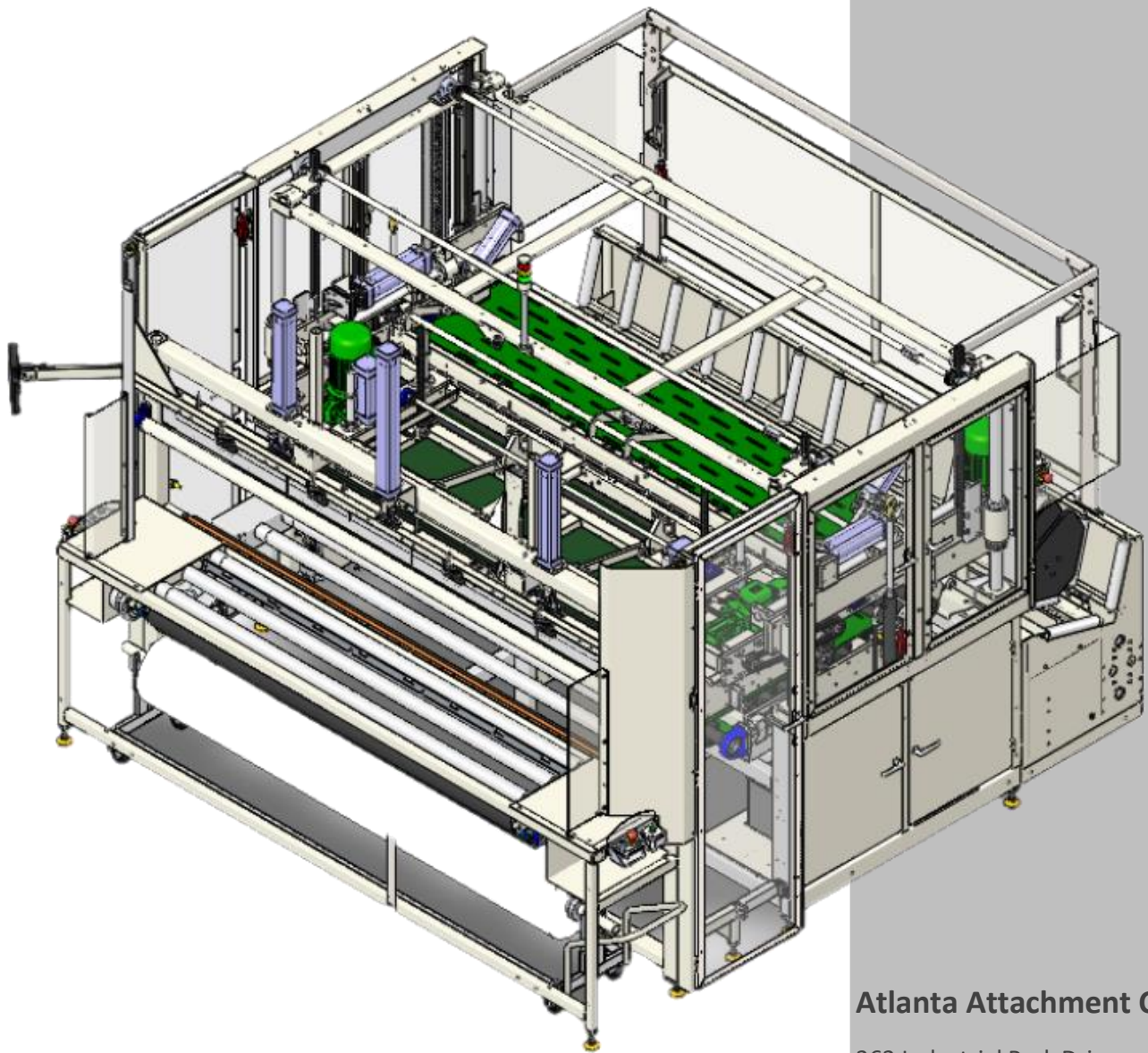

Model **1306F**
Preliminary Copy Rev.0 November 28, 2023(wr)

Technical Manual & Parts Lists



Atlanta Attachment Company

362 Industrial Park Drive

Lawrenceville, GA 30046

770-963-7369 • www.atlatt.com

Atlanta Attachment Company, Inc.

Confidential and Proprietary Information

The materials contained herein are confidential and proprietary information of Atlanta Attachment Company. In addition to any confidentiality and non-disclosure obligations that currently exist between you and Atlanta Attachment Company, your use of these materials serves as an acknowledgment of the confidential and proprietary nature of these materials and your duty not to make any unauthorized use or disclosure of these materials.

All materials contained herein are additionally protected by United States Copyright law and may not be used, disclosed, reproduced, distributed, published, or sold without the express written consent of Atlanta Attachment Company, which consent may be withheld in Atlanta Attachment Company's sole discretion. You may not alter or remove any copyright, trademark, or other notice from copies of these materials.

IMPORTANT

It is important to read and understand the information contained within this manual before attempting to operate the machine. Atlanta Attachment Co., Inc. shall not be held liable for damage resulting from misuse of the information presented within and reserves the right to change the information contained within, without prior notification.

Patents & Patents Pending

The sale of this product does not sell or otherwise transfer any license or other rights under any U.S. Patent or other corresponding foreign patent.

This equipment is manufactured under one or more of the following patents:

4,280,421 • 4,432,294 • 4,466,367 • 4,644,883 • 5,134,947 • 5,159,889 • 5,203,270 •
5,373,798 • 5,437,238 • 5,522,332 • 5,524,563 • 5,562,060 • 5,634,418 • 5,647,293
•5,657,711 • 5,743,202 • 5,865,135 • 5,899,159 • 5,915,319 • 5,918,560 • 5,924,376
•5,979,345 • 6,035,794 • 6,055,921 • 6,202,579 • 6,279,869 • 6,295,481 • 6,494,225
•6,523,488 • 6,574,815 • 6,802,271 • 6,834,603 • 6,968,794 • 6,994,043 • 7,543,364
•7,574,788 • 7,647,876 • 7,735,439

Foreign Patents: 9-520,472 • 0,537,323 • 92,905,522.6 • 96,936,922.2 • 2,076,379 •
2,084,055

Other U.S. and Foreign Patents Pending.

Contents

CONFIDENTIAL AND PROPRIETARY INFORMATION	0
SAFETY INSTRUCTION	3
Important Notices.....	6
Maintenance	8
1. INSTALLATION	11
PARTS AND COMPONENTS	11
UTILITY HOOKUPS	12
MACHINE SPECIFICATIONS	13
Power Requirements.....	13
Physical Specs:.....	13
Mattress Size Limitations:	13
OPTIONS.....	14
SET UP	15
MACHINE LAYOUT	16
MACHINE SAFETY	17
Warning 1	18
Warning 2	18
Warning 3	18
NOTE: Caution.....	18
1.1. LOCKOUT/TAGOUT PROGRAM	19
2. OPERATION	20
INDIVIDUAL COMPONENTS	20
A. Control Panel	20
B. Emergency Stop.....	20
C. Power On	20
D. Gateway /Serial Bus Control System.....	20
E. Light Tower 33001130.....	20
2.1. MACHINE SET-UP	21
Film Loading.	21
Machine Screens.	23
Styles	23
Advanced Styles, pages 1, 2 and 3	23
Advanced Settings.....	25
Resetting Piece Count.....	26
System Information.....	26
Security Information.....	26
Seal Bar Temperature Settings	27
Show All Settings Page	27
Advanced Manual Information.....	27
Compensation:.....	29
Pneumatic Cycle.....	29
VFD Drive Setup.....	30
Run Modes	32
Machine Sequence	33
Understanding the effects of the settings. (Cont'd).....	33
2.2. MACHINE OPERATION.....	39
Machine Start Up	39
General Instructions.....	40
2.3. GENERAL OPERATION	40
Advanced Settings Access Code:	40

Available Menus.....	41
1306F – Main Screen.....	41
Ready to Load Screen.....	42
Advanced Functions.....	42
Style Editing.....	43
Detailed Method.....	43
Shortest Method.....	47
2.4. MAINTENANCE.....	49
General Safety Instructions.....	49
Daily.....	49
Weekly.....	49
Monthly.....	49
2.5. PREVENTATIVE MAINTENANCE CHARTS.....	49
3. SERVICE.....	56
3.1. MECHANICAL.....	56
VFD Motor Drives and Settings.....	56
VFD Motor Drive Parameters.....	56
Main Air pressure regulator AA198-5110.....	57
Electronic Pressure Regulator AA198-3050A.....	57
Air pressure module. 4080-200.....	57
3.2. ELECTRICAL.....	58
Main Power Switch.....	58
3.3. STANDARD MODULES.....	59
Program Module...4080-150.....	59
Memory Module...4080-970.....	59
Output Module...4080-140.....	59
Optical Output Module...4080-130.....	59
Input Module...4080-110.....	59
Thermal Couple Module...4080-250.....	59
Troubleshooting.....	60
Help Screen... On board Explanations Help or detailed explanations are accessed by holding a button (actual name of function) and upon release will display information, which describes the function.	60
Error Messages.....	60
Cut Bar.....	60
Seal Bar.....	60
Air Pressure.....	60
Missing Module Error.....	60
Others.....	61
4. ASSEMBLY DRAWINGS & PARTS LISTS.....	62
11306F AUTOMATIC ROLL PACK WORKSTATION.....	63
130611195 CABINET, ELECTRICAL CONTROLS.....	64
13061196 Electrical Control Panel.....	66
13061300 ROLL PACK SUB-ASSEMBLY, GENERIC.....	69
1306096 Load Table Assembly.....	71
1306141 Cart, Plastic Rolls.....	77
13061075 Pneumatic Panel.....	79
13901091 Safety Interlock Switch Assembly.....	81
1306079 Top Compression Assembly.....	82
1306077 Pressing Conveyor Assembly.....	84
1306280 Pressing conveyor Assembly.....	86
1306377 Lower Conveyor Assembly.....	102
1306343 Conveyor, Lower.....	104

1306369 Upturn roller Assembly	106
1306601 Positioning Encoder Assembly	108
1306614 Hydraulic Power Package	109
13901096 Safety Switch Assembly	110
1306805 Roller, Pinch Assembly.....	111
1306686 Roller, Pinch Assembly.....	113
13061310 OFF-LOAD PUSHER, ROLLER	115
13061220 Motor Assembly, Off-Load Pusher	119
13061325 Pusher, Paddle Assembly	120
13061329 Ejector Arm Mount Assembly	121
13061351 Sprocket Assembly, Inside	122
13061330 GUARDING AND SHIELDS, OUTFEED	123
14061500 FOLD-IN-HALF CONVEYOR.....	124
14061230 Conveyor Frame Assembly, Left	130
14061235 Conveyor Frame Assembly, Right	132
14061236 Light Curtain Control Assembly	133
14061245 Sprocket Idler Assembly.....	134
14061250 Pusher Assembly	135
14061270 Pusher Transfer Assembly	136
14061274 Pusher Cylinder Assembly.....	137
14061278 Lower Sensor Assembly.....	138
14061280 Left Conveyor Assembly.....	139
14061290 Right Conveyor Assembly	140
14061295 Solenoid, 4-Valve Assembly	142
14061300 Electrical Panel, Fold-in-half	143
14061500-CAB Cable Kit	144
1406382 Cylinder Assembly.....	145
1406545 Push Plate Assembly	146
1306F-WD1 WIRING DIAGRAM. CONTROL BOX, POWER.....	147
1306F-WD2 WIRING DIAGRAM, SERIAL BUS.....	148
1306F-WD3 WIRING DIAGRAM, SAFE PAUSE & E-STOP	149
1306F-WD4 WIRING DIAGRAM, SAFETY CIRCUIT	150
1306D-PD PNEUMATIC DIAGRAM.....	151
1306-PD3 PNEUMATIC DIAGRAM.....	152
5. TRAINING	153
ATLANTA ATTACHMENT COMPANY (AAC) STATEMENT OF WARRANTY	154
MANUFACTURED PRODUCTS	154
TERMS AND CONDITIONS:.....	154
WHAT IS COVERED	154
WHAT IS NOT COVERED.....	154
DECLARACIÓN DE GARANTIA	155
PRODUCTOS MANUFACTURADOS	155
TÉRMINOS Y CONDICIONES:	155
LO QUE ESTÁ GARANTIZADO.....	155
LO QUE NO ESTÁ GARANTIZADO	155
6. INDEX	156
7. NOTES:.....	157

Safety Instruction



This part of the Instruction Material is provided for the safe use of your equipment. It contains important information to help work safely with the unit and describes the dangers inherent in machinery. Some of these dangers are obvious, while others are less evident.

Mandatory Information

All persons operating and/or working on the Workstation 1331B&BD, should read and understand all parts of the Safety Instructions. This applies, in particular, for persons who only operate and/or work on the unit occasionally (e.g. for maintenance and repair). Persons who have difficulty reading must receive particularly thorough instruction.

Scope of the Instruction Material

The Instruction Material comprises:

- Safety information
- Operator Instructions
- Electrical and Pneumatic diagrams

And may also include.

- A list of recommended spare parts
- Instruction Manual(s) for components made by other manufacturers
- The layout and installation diagram containing information for installation

Intended Use

Our machines are designed and built-in line with the state of the art and the accepted safety rules. However, all machines may endanger the life and limb of their users and/or third parties and be damaged or cause damage to other property, particularly if they are operated incorrectly or used for purposes other than those specified in the Instruction Manual.

Exclusion of Misuse



Non-conforming uses include, for example, using the equipment for something other than it was designed for, as well as operation without duly installed safety equipment. The risk rests exclusively with the end user.

Conforming use of the machine includes compliance with the technical data, information, and regulations in all parts of the complete Instruction Material, as well as compliance with the maintenance regulations. All local safety and

accident prevention regulations must also be observed.

Liability

The machine should only be operated when in perfect working order, with due regard for safety and the potential dangers, as well as in accordance with the Instruction Material. Faults and malfunctions capable of impairing safety should be remedied immediately. We cannot accept any liability for personal injury or property damage due to operator errors or non-compliance with the safety instructions contained in this booklet. The risk rests exclusively with the end user.

The Instruction Material should always be kept near the machine so that it is accessible to all concerned.

The local, general, statutory, and other binding regulations on accident prevention and environmental protection must also be observed in addition to the Instruction Material. The operating staff must be instructed accordingly. This obligation also includes the handling of dangerous substances and provision/use of personal protective equipment.

The Instruction Material should be supplemented by instructions, including supervisory and notification duties with due regard for special operational features, such as the organization of work, work sequences, the personnel deployed, etc.

The personnel's awareness of the dangers and compliance with the safety regulations should be checked at irregular intervals.

Choice and Qualification of Personnel

Ensure that work on the machine is only carried out by reliable persons who have been appropriately trained for such work - either within the company, by our field staff or at our office - and who have not only been duly appointed and authorized but are also fully familiar with the local regulations. Work on the machine should only be carried out by skilled personnel, under the management and supervision of a duly qualified engineer.

This not only applies when the machine is used for production, but also for special work associated with its operation (start-up and maintenance), especially when it concerns work on the hydraulic or electrical systems, as well as on the software/serial bus system.

Training

Everyone working on or with the machine should be duly trained and informed about correct use of the safety equipment, the foreseeable dangers which may arise during operation of the machine and the safety precautions to be taken. In addition, the personnel should be instructed to check all safety mechanisms at regular intervals.

Responsibilities

Clearly define exactly who is responsible for operating, setting-up, servicing and repairing the machine. Define the responsibilities of the machine operator and authorize him to refuse any instructions by third parties if they run contrary to the machine's safety. This applies for the operators of machines linked to other equipment. Persons receiving training of any kind may only work on or with the machine under the constant supervision of an experienced operator. Note the minimum age limits permitted by law.

A Word to the Operator

The greatest danger inherent in our machines: is that of fingers, hands or loose clothing being drawn into a machine by live, coasting or rotating tools or assemblies or of being cut by sharp tools or burned by hot elements.

Always be conscious of these dangers!

Safety Equipment on the Machines



All machines are delivered with safety equipment, which shall not be removed or bypassed during operation.

The correct functioning of safety equipment on machines and systems should be checked every day and before every new shift starts, after maintenance and repair work, when starting up for the first time and when restarting (e.g. after prolonged shutdowns).

If safety equipment has to be dismantled for setting-up, maintenance or repair work, such safety equipment shall be replaced and checked immediately upon completing the maintenance or repair work.

All protective mechanisms shall be fitted and fully operational whenever the machine is at a standstill or if it has been shut down for a longer period.

Damage

If any changes capable of impairing safety are observed in the machine or its mode of operation, such as malfunctions, faults or changes in the machine or tools, appropriate steps must be taken immediately, the machine switched off and a proper lockout tagout procedure followed. The machine should be examined for obvious damage and defects at least once per

shift. Damage found shall be immediately remedied by a duly authorized person before resuming operation of machine.

The machine should only be operated when in perfect working order and when all protective mechanisms and safety equipment, such as detachable protective mechanisms, emergency STOP systems, etc. are in place and operational.

Faults or Errors

The machine must be switched off and all moving or rotating parts allowed to come to a standstill and secured against accidental restart before starting to remedy any faults or errors.

Signs on the Machine

Safety and danger signs on the machine should be observed and checked at regular intervals to ensure that they are complete and undamaged. They should always be clearly visible and legible.

Clothing, Jewelry, Protective Equipment

Long loose hair, loose-fitting clothes, gloves, and jewelry, including rings, should be avoided in order to avoid injuries due to being caught, drawn in and wound up inside the machine.

Protective Eyewear

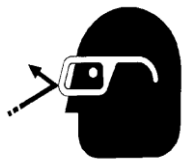

Protective eyewear that has been tested by the local authorities should be worn whenever there is a possibility of loose or flying objects or particles such as when cleaning the machine with compressed air.

Tools

Always count the number of tools in your possession before starting work on the machine. This will allow you to check that no tools have been left behind inside the machine. Never leave a tool in the machine while working.

Oils, Lubricants, Chemicals

Note the applicable safety regulations for the product used.

No Smoking, Fire, Explosion Hazard

Smoking and open flame (e.g. welding work) should be prohibited in the production area due to the risk of fire and explosions.

Workplace

A clear working area without any obstructions whatsoever is essential for safe operation of the machine. The floor should be level and clean, without any waste.

The workplace should be well lit, either by the general lighting or by local lights.

Emergency STOP

The emergency STOP buttons bring all machine movements to a standstill. Make sure you know exactly where they are located and how they work. Try them out. Always ensure easy access to the nearest emergency STOP button while working on the machine.

First Aid

1. Keep calm even when injured.
2. Clear the operator from the danger zone. The decision of what to do and whether to seek additional assistance rests entirely with you, particularly if someone has been trapped.
3. Give First Aid. Special courses are offered by such organizations as the employers' liability insurance association. Your colleagues should be able to rely on you and vice versa.
4. Call an ambulance. Do you know the telephone numbers for the ambulance service, police and fire service?

Important Notices

Reporting and Fighting Fires

Read the instructions posted in your factory about reporting fires and the emergency exits. Make sure you know exactly where the fire extinguishers and sprinkler systems are located and how they are operated. Pass on the corresponding information to the firemen when they arrive. Ensure there are enough signs to avoid fire hazards.

The following fire extinguishers may be used:

- Dry powder extinguishers, ABC fire-extinguishing powder.
- Carbon dioxide fire extinguishers to DIN 14461 for electronic components. Great care must be exercised when using carbon dioxide fire extinguishers in confined, badly ventilated rooms (see DIN 14406 and 14270).

Isolate the machine from the power supply if a fire breaks out. Do not use water on burning electrical parts until it is certain that they have been completely disconnected from the power supply. Burning oils, lubricants, plastics, and coatings on the machine can give off gases and vapors that may be harmful to your health.

A qualified person should be consulted to repair the damage after a fire.

Electrical Power Supply



Before undertaking any maintenance or repair work on the machine, switch off the electrical power to the machine at the main source and secure it with a padlock so that it cannot be switched on again without authorization.

In practice, this may mean that the technician, electrician, and operator all attach their own padlock to the master switch simultaneously so that they can carry out their work safely. Locking extension plates should be available for multiple locks if required. The primary purpose for a lockout/tagout

procedure is to protect workers from injury caused by unexpected energizing or start-up of equipment.

Energy sources (electrical/pneumatic/hydraulic, etc.) for the equipment shall be turned off or disconnected and the switches locked or labeled with a warning tag. It is the responsibility of the employer to establish control procedures. Follow lockout/tagout procedures before, setup and/or any service or maintenance work is performed, including lubrication, cleaning, or clearance of jams.

Caution: The machine is still not completely de-energized even when the master switch is off.

- Electricity - The machine is always isolated from the electrical power supply whenever the master switch has been switched off. However, this does not apply for the power supply in the control cabinet, nor for equipment that does not draw its power via the master switch.

- Pneumatic / hydraulic energy - Almost all our machines carry compressed air. In addition to switching off the master switch, the air supply must also be disconnected, and the machine checked to ensure it is depressurized before starting any work on the machine; otherwise, the machine may execute uncontrolled movements.

- Kinetic energy - Note that some motors or spindles, for example, may continue to run or coast run on after being switched off.

Potential energy - Individual assemblies may need to be secured if necessary for repair work.

Delivery of the Machine/Packaging

Note any markings on the packaging, such as weights, lifting points and special information. Avoid temperature fluctuations. Condensation may damage the machine.

Transport Damage

The packaging and machine must immediately be examined for signs of damage in transit. Such damage must be reported to the shipper/transporter within the applicable time limits. Contact Atlanta Attachment Company and/or your transport insurer immediately, if signs of damage are visible. Never operate a damaged machine.

Interim Storage

If the machine has to be stored temporarily, it must be oiled or greased and stored in a dry place where it is protected from the weather in order to avoid damage. A corrosion-inhibiting coating should be applied if the machine must be stored for a longer period of time and additional precautions taken to avoid corrosion.

Transporting the Machine

Disconnect the machine from all external connections and secure any loose assemblies or parts. Never step under a suspended load. When transporting the machine or assemblies in a crate, ensure that the ropes or arms of a forklift truck are positioned as close to the edge of the crate as possible. The center of gravity is not necessarily in the middle of the crate. Note the accident prevention regulations, safety instructions and local regulations governing transport of the machine and its assemblies.

Only use suitable transport vehicles, hoisting gear and load suspension devices that are in perfect working order and of adequate carrying capacity. Transport should only be entrusted to duly qualified personnel.

Never allow the straps to rest against the machine enclosure and never push or pull sensitive parts of the machine. Ensure that the load is always properly secured. Before or immediately after loading the machine, secure it properly and affix corresponding warnings. All transport guards and lifting devices must be removed before the machine is started up again. Any parts that are to be removed for transport must be carefully refitted and secured before the machine is started up again.

Workplace Environment

Our machines are designed for use in enclosed rooms: Permissible ambient temperature approx. 5 - 40 °C (40 - 104 °F). Malfunctions of the control systems and uncontrolled machine movements may occur at temperatures outside this range.

Protect against climatic influences, such as electrostatic charges, lightning strikes, hail, storm damage, high humidity, salinity of the air in coastal regions.

Protect against influences from the surroundings: no structure-borne vibrations, no grinding dust, or chemical vapors.

Protect against unauthorized access.

Ensure that the machine and accessories are set up in a stable position.

Ensure easy access for operation and maintenance (Instruction Manual and layout diagram); also verify that the floor is strong enough to carry the weight of the machine.

Local Regulations

Particular attention must be paid to local and statutory regulations, etc. when installing machines and the plant (e.g. with regard to the specified escape routes). Note the safety zones in relation to adjacent machines.

Maintenance

General Safety Instructions

The machine shall be switched off, come to a standstill, and be secured so that it cannot be switched on again inadvertently before starting any maintenance work whatsoever. Use proper lockout/tagout procedures to secure the machine against inadvertent startup.

Remove any oil, grease, dirt, and waste from the machine, particularly from the connections and screws, when starting the maintenance and/or repair work. Do not use any corrosive-cleaning agents. Use lint-free rags.

Retighten all screw connections that must be loosened for the maintenance and repair work.

Any safety mechanisms that must be dismantled for setting-up, maintenance or repair purposes must be refitted and checked immediately after completing the work.

Maintenance, Care, Adjustment

The activities and intervals specified in the Instruction Manual for carrying out adjustments, maintenance and inspections must be observed, and parts replaced as specified.

All hydraulic and pneumatic lines should be examined for leaks, loose connections, rubbing and damage whenever the machine is serviced. Any defects found must be remedied immediately.

Waste, Disassembly, Disposal

Waste products should be cleared from the machine as soon as possible as not to create a fire hazard.

Ensure that fuels and operating lubricants, as well as replacement parts are disposed of in a safe and ecologically acceptable manner. Note the local regulations on pollution control.

When scrapping (disassembling) the machine and its assemblies, ensure that these materials are disposed of safely. Either commission a specialist company familiar with the local regulations or note the local regulations when disposing of these materials yourself. Materials should be sorted properly.

Repair

Replacement Parts

We cannot accept any liability whatsoever for damage due to the use of parts made by other manufacturers or due to unqualified repair or modification of the machine.

Repair, Electrical

The power supply must be switched off (master switch off) and secured so that it cannot be switched on again inadvertently before starting any work on live parts.

Those parts of the machine and plant on which inspection, maintenance or repair work is to be carried out must be isolated from the power supply, if specified. The isolated parts must first be checked to determine that they are truly de-energized before being grounded and short-circuited. Adjacent live parts must also be isolated.

The protective measures implemented (e.g. grounding resistance) must be tested before restarting the machine after all assembly or repair work on electric parts.

Signal generators (limit switches) and other electrical parts on the safety mechanisms must not be removed or bypassed. Only use original fuses or circuit overloads with the specified current rating. The machine must be switched off immediately if a fault develops in the electrical power supply.

The electrical equipment of our machines must be checked at regular intervals and any defects found must be remedied immediately.

If it is necessary to carry out work on live parts, a second person should be on hand to operate the emergency OFF switch or master switch with voltage release in the event of an emergency. The working area should be cordoned off and marked by a warning sign. Only use electrically insulated tools.

Ventilation/Hazardous Gases

It is the end user's responsibility to ensure adequate ventilation is provided to exhaust any and all noxious or hazardous gases that may be present in the working environment.

Hydraulic and Pneumatic Systems

Work on hydraulic or pneumatic equipment shall only be carried out by persons with training, knowledge, and experience of hydraulic systems. Pressure lines shall be depressurized before starting any repair work.

General Liability

Liability for machine damage and personal injury is extinguished completely if any unauthorized conversions or modifications are undertaken. The machine must not be modified, enlarged or converted in any way capable of affecting safety without the manufacturer's prior approval.

Starting Machine Movements

Read the Instruction Manual carefully to establish which keys and functions start machine movements.

A Word to the End User

The end user has sole responsibility to enforce the use of safety procedures and guards on the machine. Any other safety devices or procedures due to local regulations should be retrofitted in accordance to these regulations and/or the EC Directive on the safety of machines.

Operator's position must always be readily accessible. Escape routes must always be kept clear and safety areas should be identified.

Safety Precautions

Safety should be a constant concern for everyone. Always be careful when working with this equipment. While normal safety precautions were taken in the design and manufacture of this equipment, there are some potential safety hazards.

Everyone involved with the operation and maintenance of this equipment should read and follow the instructions in this manual. Operate the equipment only as stated in this manual. Incorrect use could cause damage to the equipment or personal injury.

It is the owner's responsibility to make certain that the operator reads and understands this manual before operating this equipment. It is also the owner's responsibility to make certain that the operator is a qualified and physically able individual, properly trained in the operation of this equipment.

Specific safety warning decals are located on the equipment near the immediate areas of potential hazards. These decals should not be removed or obliterated. Replace them if they become non-readable.

- ALWAYS keep safety shields and covers in place, except for servicing.
- ALWAYS operate equipment in daylight or with adequate working lights.
- Follow daily and weekly checklists, making sure hoses are tightly secured and bolts are tightened.
- ALWAYS watch and avoid holes or deep depressions.

ALWAYS wear adequate eye protection when servicing the hydraulic system and battery.

- NEVER operate a poorly maintained machine.
- NEVER allow persons to operate this machine without proper instruction.
- NEVER put hands or feet under any part of the machine while it is running.
- NEVER attempt to make any adjustments or repairs to the machine while running. Repairs or maintenance should be performed by trained personnel only.
- NEVER work under the machine unless it is safely supported with stands, blocks or a hoist and blocks.
- NEVER touch hot parts of machine.

1. INSTALLATION

It is important that the machine operator read this manual and is familiar with all the functions and safety concerns of the unit before Installing and operating.

Parts and Components

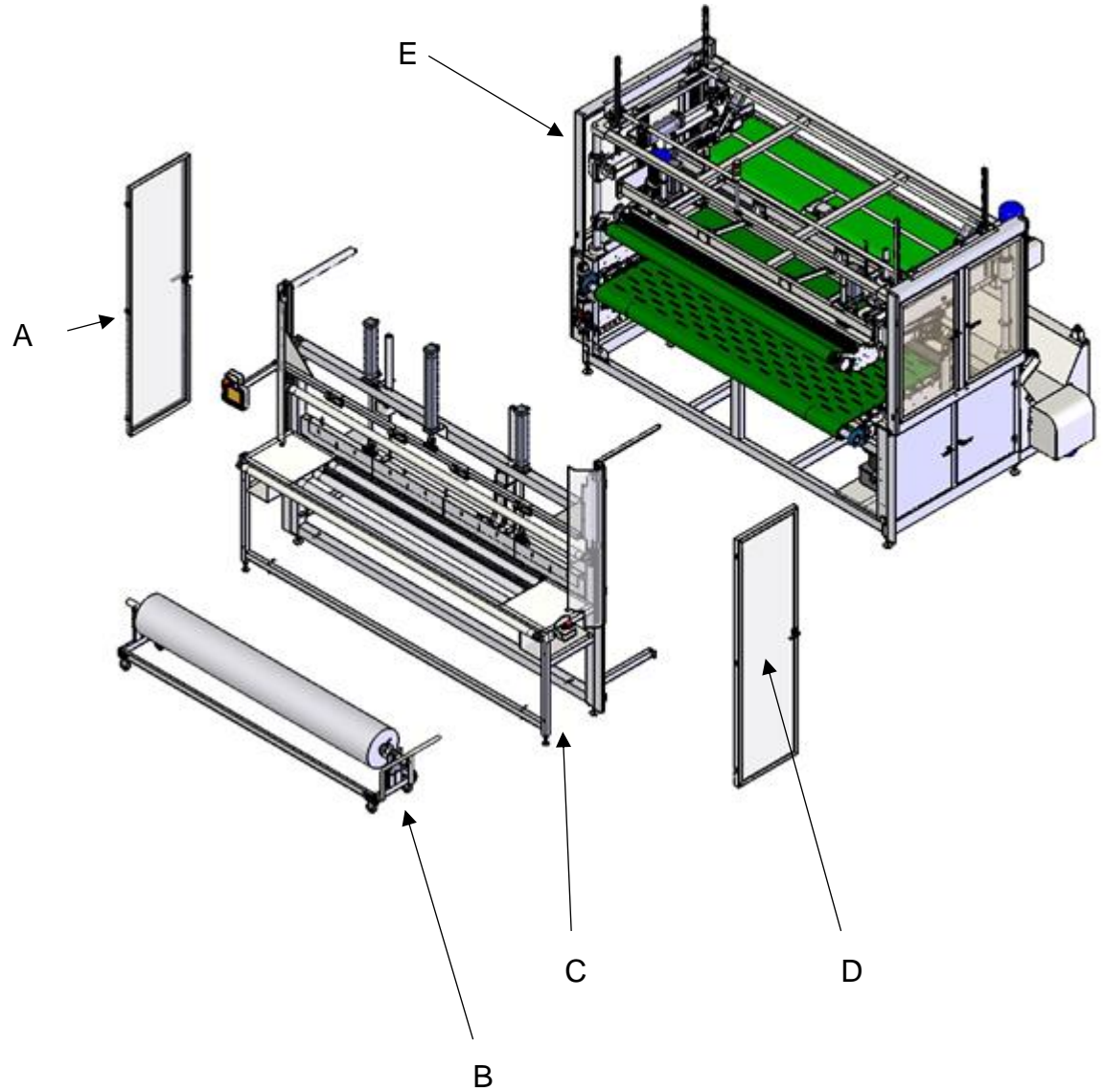

Fig 1

- A. Left door
- B. Roll Storage cart
- C. Infeed unit
- D. Right Door
- E. Main Unit

Utility Hookups

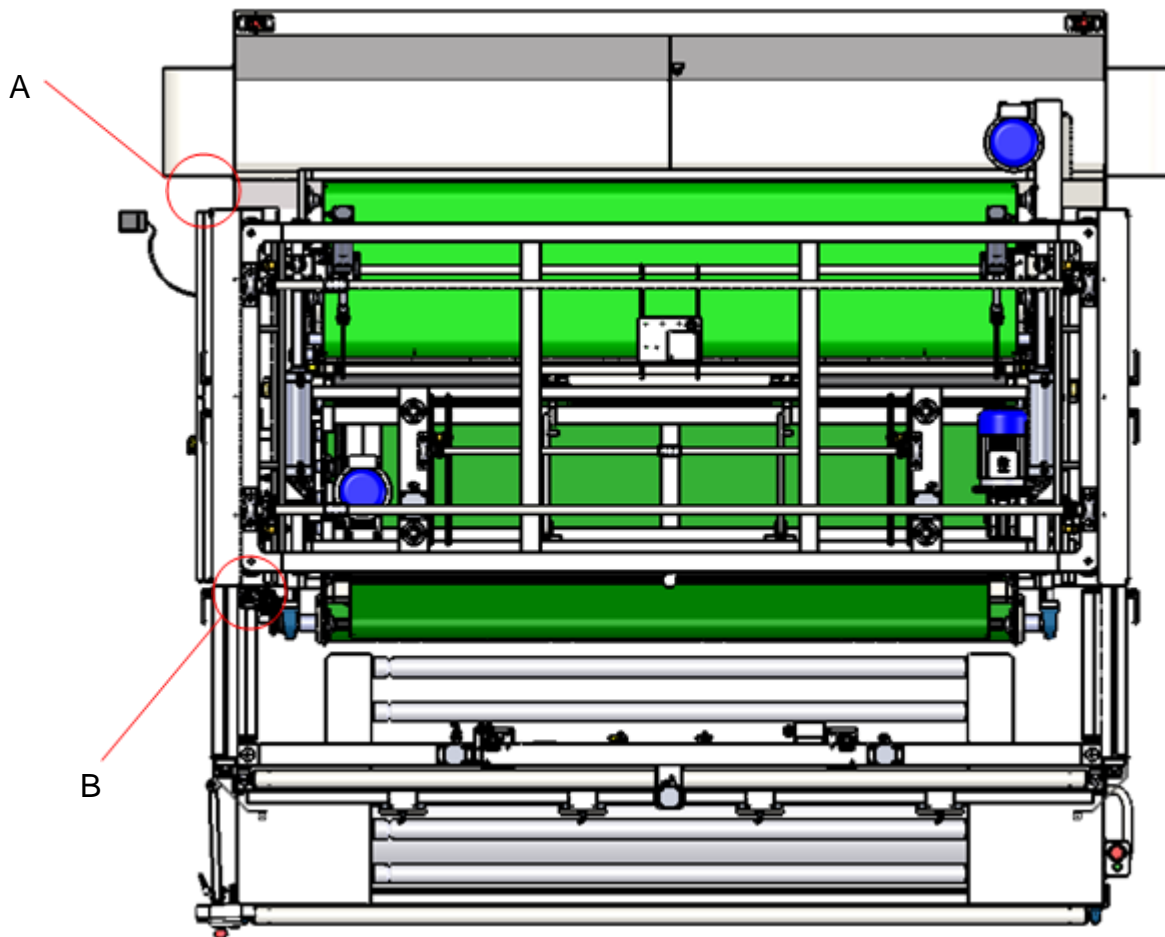

Fig. 2

Top View of 1306F

- A. Electrical drop = 208v-240v 50hz/60hz 50amp circuit
- B. Air drop = 100 psi dried shop air. 3/8-inch line minimum.

Machine Specifications

Capacity & Production Specs.

Production / Through Put	1 -2 pieces per minute
Max Width of Mattress	86" wide
Max Height under Pressure Roller:	15" wide
Roll capacity, bottom	1 roll (12" diameter)
Film width: Bottom (inch)	92"

Power Requirements

Volts	208V-240V -- 3-phase 50/60 Hz
Amps	50A Full Load
Power Connection Locations	Single

Pneumatic Pressure Requirements

Air Consumption in SCFM	20 SCFM
Air Pressure	100 Psi
Air Connection	1 – 2 hookups

Physical Specs:

Infeed/Outfeed Conveyor Height	36-38" +/-
Overall Dimensions	139"w X 118'l X 99"h
Machine Weight (lbs.)	??? weight varies with options
Shipping weight (lbs.)	??? weight varies with options

Mattress Size Limitations:

Mattress Width Max	86" Wide
Mattress Height Max	15" wide

Notes:

- Automatically compress & pack one-two (1-2) units per minute
 - (Actual time may vary depending on size and density of beds)
- Accepts finished mattress and soft cushions made from foam (without border wire)
- Wrapper - PE, PVC & PU
- Compact design minimizes floor space
- Patented Control System
- Low and easy maintenance
- Easy to operate

Options

- 11307SA Auto Secondary Roll Pack
- 13061395 Raised Mattress Boxing Table
- 1306141 - Plastic Roll Carriage



- LSC2005 Conveyor System
- Extended Loading Table Use in case of no Conveyor System
- Pre-fold System Use in conjunction with Auto-Pac™ (1390) with Compression Module

Set Up

- Remove any shipping straps from machine.
- Inspect the machine for any damage that may have occurred during shipping. If damage is found, report this immediately to your supervisor. Document the damage and provide details and photographs.
- Position the main unit in a desired location on a sound and reasonably level floor. Make sure that there is sufficient lighting over the machine. Remove all packing material. Adjust the jack screws so the machine is level and approximately 3" high from the floor to the bottom of the jack screw mount plate.
- Move In-feed unit into position using the lower connector arm to properly space the bottom from the main unit. Install screws loosely.
- Adjust feet on In-feed to line up holes on upper connector bracket and screw into place. Fully tighten connector bolts on lower connector bracket.
- Attach heater wire to the cut bar relay inside the control box.
- Attach feed start emitter and feed start sensor to serial bus modules marked on sensor wires inside control box
- Connect (2) Main power/E-stop connectors from In-feed table to the back of the control box.
- Connect the touch screen connector to the touch screen serial bus wire hanging from the rear of the control box.
- Connect serial bus extension wire to the thermocouple module on in feed.
- Attach right and left doors to In-feed table.
- Provide a **220v AC, Three Phase, 50 Amps** at location specified in fig. 7.
- Provide **3/8" ID air supply line (90 PSI)** at location specified in Fig. 2.



Turn the main air lock-out valve (Red Knob before the main pressure regulator) to the "ON" position.



Twist all four E-Stop Knobs to return to their normal position.

Turn the machine "ON" by pressing the green button "A" on the box just above the touch screen. The machine will first display the language choices and after several seconds it will show the "Ready" page. This screen is the one that the operator should always see upon power up if the serial bus is operating properly.

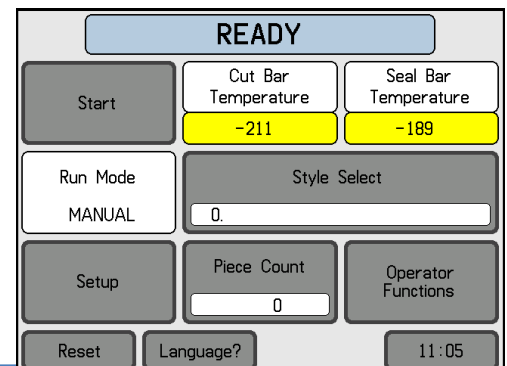

Machine Layout

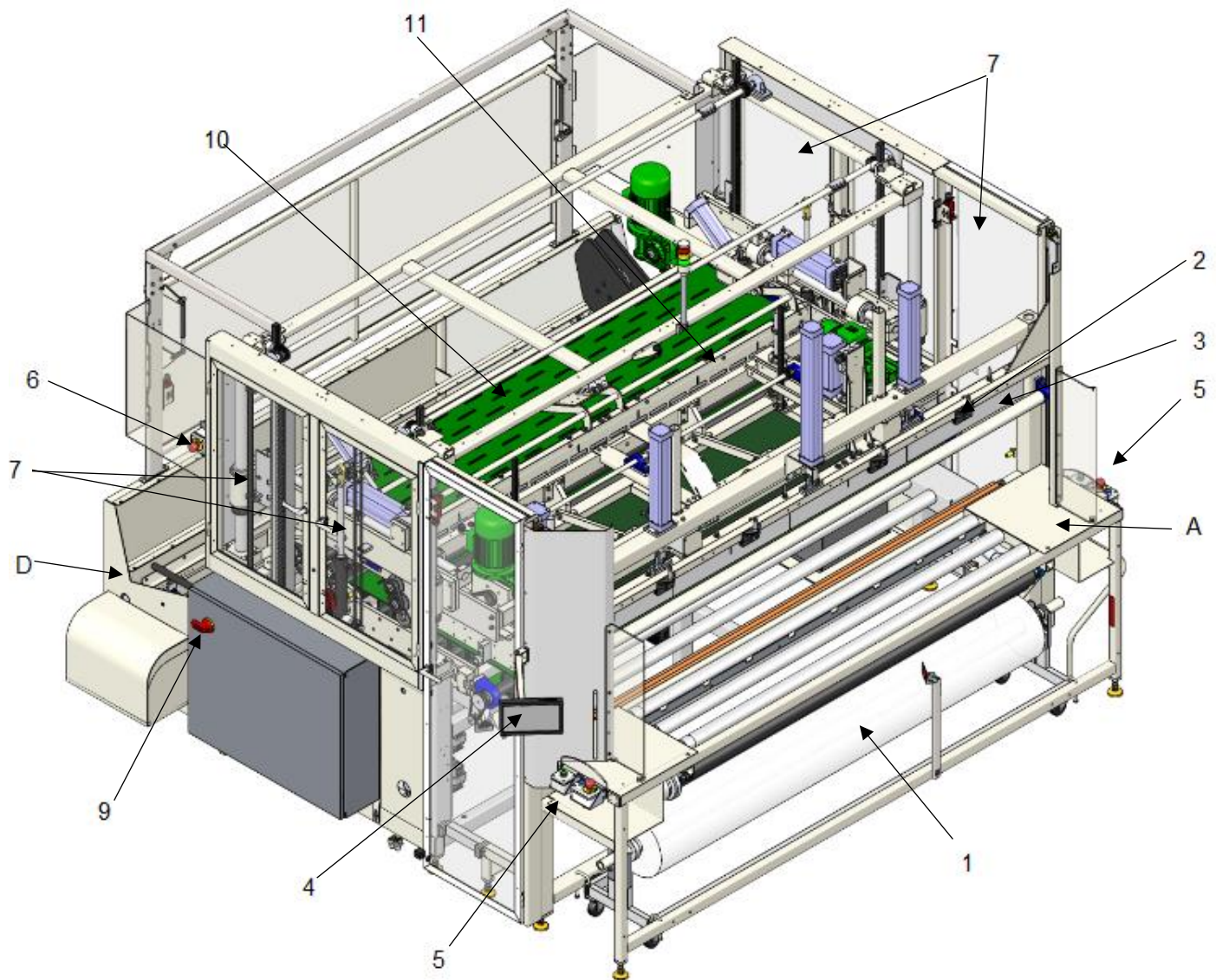

A. In-feed Unit

1. Roll Storage Cart.
2. Plastic Hold Down Bar.
3. Heated Cut Bar.

B. Machine Controls

4. Touch Screen
5. Infeed E-Stop and Power Switch.
6. Out-feed E-stop and Power switch.
7. Side Access Doors.
- 8.
9. Main Power Shut-Off

C. Main unit

10. Upper Pressing Platform
11. Rear Cross Seal

D. Output Carriage unit

Machine Safety

The 1306 model roll pack workstation has many powerful drives and mechanisms.

ANYONE assigned to operate and/or maintain this machine must be properly trained by an Atlanta Attachment Technician, or a trained and qualified factory mechanic.

Operation and/or maintenance of this machine by untrained personnel may result in a serious injury or even death.

ANYONE assigned to operate and/or maintain this machine must read, understand, and follow the safety guidelines listed below and mentioned in the following pages. They must also be familiar with the locations of all operators' controls, with particular emphasis on the following:

- Main Electrical Power Shut Off
- Main Pneumatic Air Supply On/Off Valve
- Four Emergency-Stops, Located in the four corners of the machine.
- All Access doors being open will pause the machine in automatic mode. The doors "**Will NOT**" stop motion in Advanced manual mode.

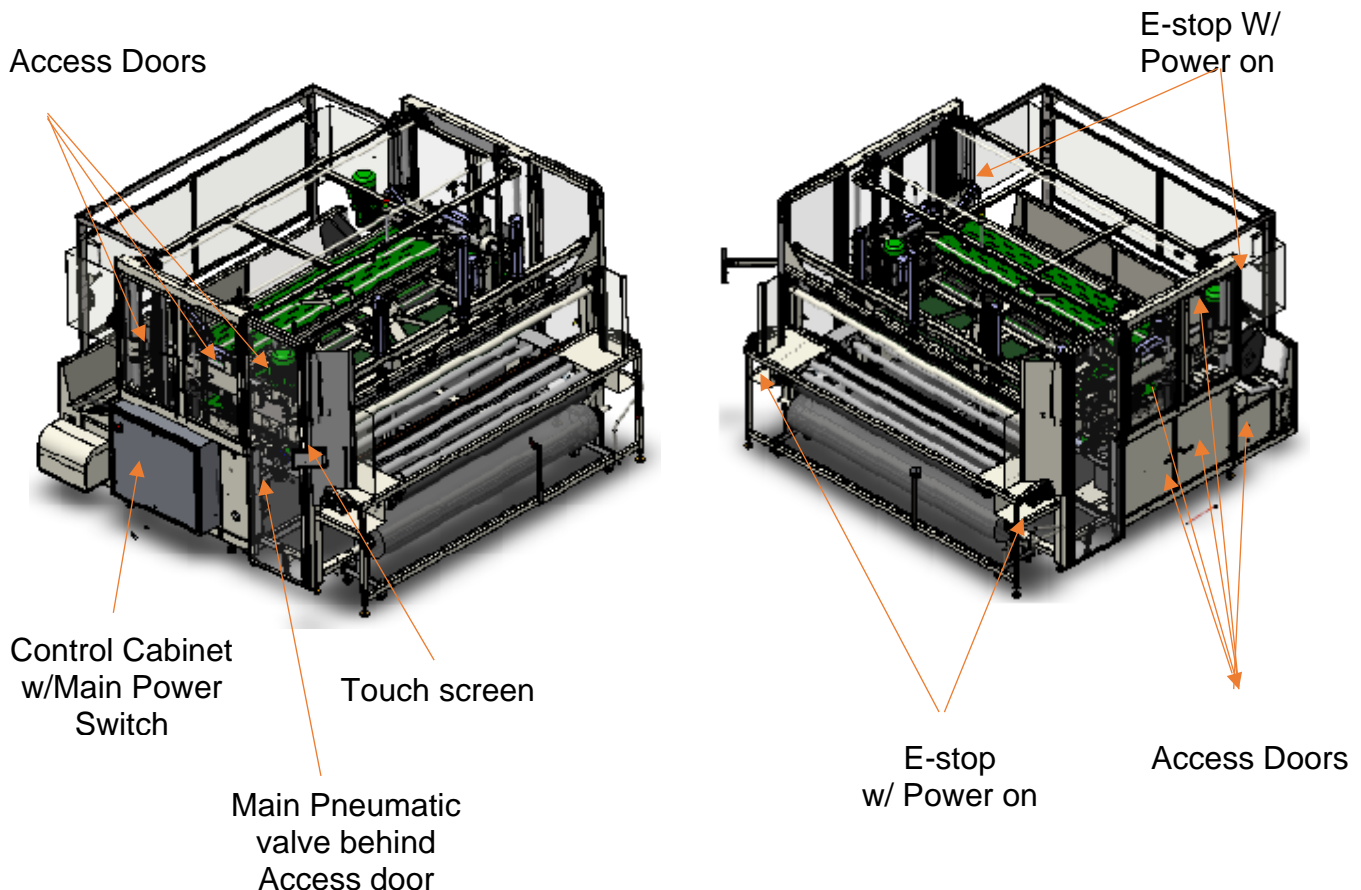

Warning 1

The machine makes automatic movements at the beginning of power up that could pinch, crush, or kill a person inside the machine. Also never allow anyone in or on the machine when powering up.

In auto mode this machine can start automatically once the In-feed sensor is covered. If the In-feed sensor should fail, in auto mode the machine could start moving without a bed being feed into the machine. For this reason, When the machine is in auto mode and the ready to load screen is active:



- NEVER ENTER INSIDE THE MACHINE.**
- NEVER CRAWL UNDER THE MACHINE.**
- NEVER CLIMB ON TOP OF THE MACHINE.**
- NEVER REACH INSIDE THE MACHINE FOR ANY REASON.**
- NEVER PLACE ANY PART OF YOUR BODY INSIDE THE MACHINE.**

Fig 4

Warning 2

In advanced manual mode, this machine may be prompted to execute any of its functions. Therefore, to prevent injury or machine damage, only a properly trained operator or mechanic should use the machine in this mode of operation.

Warning 3

To perform any machine maintenance always follow the steps below:

1. FIRST, POWER DOWN THE MACHINE AND LOCK-OUT THE ELECTRICAL AND PNEUMATIC POWER SWITCHES.
2. WAIT UNTIL SEAL BARS COOL OFF SUFFICIENTLY (APPROX. 3 HOURS) BEFORE SERVICING THE SEAL BARS OR NEARBY AREAS OF THE MACHINE.
3. NEVER ENTER OR ALLOW ANYONE ELSE TO ENTER INSIDE THE MACHINE DURING A POWER UP OR ENERGIZING WITH AIR PRESSURE!

NOTE: Caution

If machine maintenance is necessary before seal bars have sufficiently cooled off, a service person must wear OSHA approved safety gear to protect himself/herself from a potential burn.



1.1. Lockout/Tagout Program



Lockout/Tagout (LOTO)" refers to specific practices and procedures to safeguard employees from the unexpected energization or startup of machinery and equipment, or the release of hazardous energy during service or maintenance activities. This requires that a designated individual turns off and disconnects the machinery or equipment from its energy source(s) before performing service or maintenance and that the authorized employee(s) either lock or tag the energy-isolating device(s) to prevent the release of hazardous energy and take steps to verify that the energy has been isolated effectively. The following references provide information about the LOTO process.

Equipment Energy Control Procedure			
Lockout/Tagout Program			
Description:	Roll Pack Workstation	Model:	1306F
Manufacturer:	Atlanta Attachment Co.	Location:	
Energy	Location	Magnitude	Control Method
Electrical:	Disconnect/Ctrl Box	220V--3 PH	Lockout & Tag
Pneumatic:	Main Regulator	90 PSI	Lockout & Tag
Gravity:	Cut bar Assy, presser belt Assy, Seal Bar assembly, Plastic Holder Clamp		
Remember to Release All Stored Energy!			
Shutdown Procedure:			
<ol style="list-style-type: none"> 1. Inform all affected personnel that the machine will be in Lockout status. 2. Turn the power and pneumatic disconnects to the OFF position. 3. Fill out the tag with necessary information of the Lockout. 4. Install the Lockout device. 5. Verify all stored electrical energy has been released by pressing the power on button . Also, use meter to test circuits in the electrical panel to insure stored energy is released there as well. Perform necessary maintenance, services and/or repairs. 			
Startup Procedure:			
<ol style="list-style-type: none"> 1. Inform all affected personnel that the Lockout of this machine is being removed. 2. Replace any guards or safety devices which may have been removed during maintenance. 3. Remove the Lockout device and tag. 4. Turn the power and pneumatic disconnects to the ON position. 5. Push the green button on the back of the control panel to turn the machine on. 6. Inform all affected personnel that the Lockout has been removed and that the machine is ready for normal production operation. 			

Approved By: _____

Date: _____

2. OPERATION

It is important that the machine operator read this manual and is familiar with all the functions and safety concerns of the unit before operating.

Individual Components

A. Control Panel

The Control Panel allows the operator to start and stop the automatic function of the machine, shut off power to the machine in the event of an emergency.

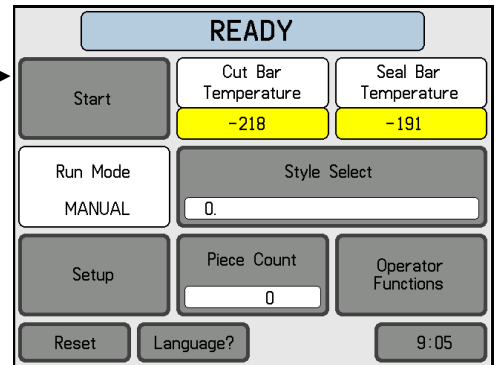

B. Emergency Stop

Pressing this button will turn off power to the machine. This button will lock when pressed. Twisting the button will cause it to unlock and return to its normal position.



WARNING!! Unlocking the button with the Power On engaged will turn on power to the machine.



C. Power On

Power the machine "ON".

D. Gateway /Serial Bus Control System

Control all machine functions. See more details available on related chapters one this manual



E. Light Tower 33001130

The purpose of the light tower is to indicate status of the machine at some distance away from the machine. This makes it easy to see machine status at a glance. Definitions for the different light states currently available on the 4300 are included below.



Light Status	Definition
Green Steady:	Machine is operational and up to temperature.
Green Flashing:	Machine is in warm up sequence.
Yellow Steady:	Machine is in advanced manual mode.
Yellow Flashing:	Machine is currently in cycle.
Red Steady:	Safety Doors Open.
Red Flashing:	Heating element(s) have gone into over temp state.

2.1. Machine Set-up

Film Loading.

The Standard machine comes with a pull-out film roll cart that can handle a 12" diameter x 92" long roll of plastic.

The film cart can be loaded two ways. It can be inserted from the left or the right of the machine for loading.

To load the rack

1. pull out the (2) locating/locking pins (one on each side of the machine) to unlock the cart from the machine.
2. Pull rack out from under the machine far enough to load the rolls of film.
3. Remove roll holder bar from cart.
4. Remove retaining collar on the opposite end of the bearing retainer collars.
5. Insert plastic retaining bar into core of plastic roll

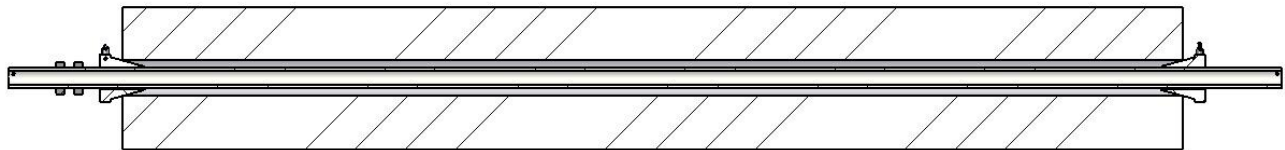

Correct

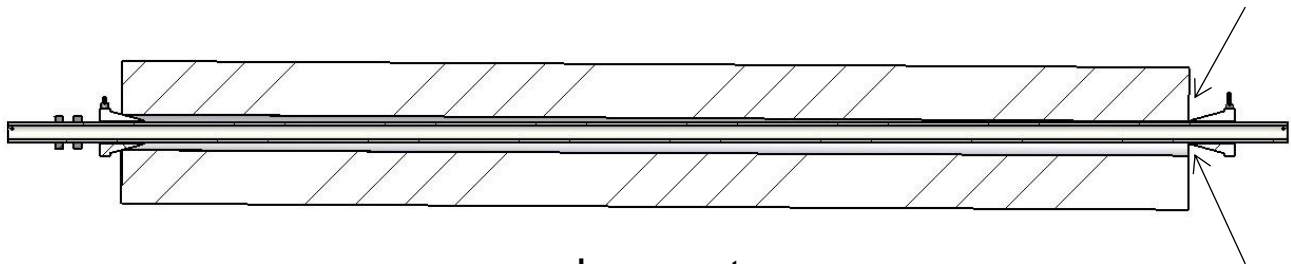

Incorrect

Fig 5

6. Replace collar on roll holder bar to center roll holder inside roll core.

NOTE: Make sure both collars are in the core, tight and roll will spin relatively free on Film Holder.

7. Using a fork truck / 2 or more men, place plastic roller holder bar back on cart.

8. Insert cart under in feed table and replace pins.

9. Route plastic as shown in diagram.

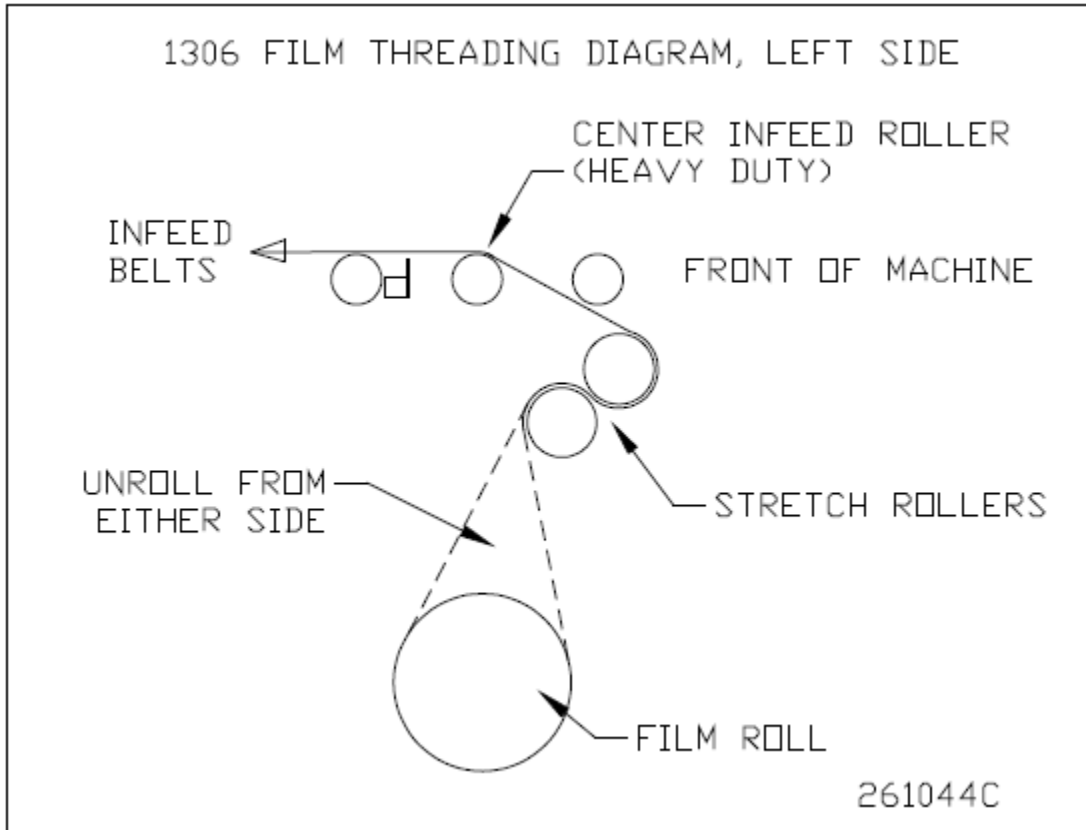

Load Plastic until it reaches the cut bar location and hold preventing it from slipping off infeed,

10. Refer to Ready Screen and press Operator Functions Button for access to Film Cut/Load Button as shown below

Push Button "Film Cut / Load Cycle to manually activate this function to clamp plastic. 

NOTE: Be sure all pinch points and hands are clear before activating cycle

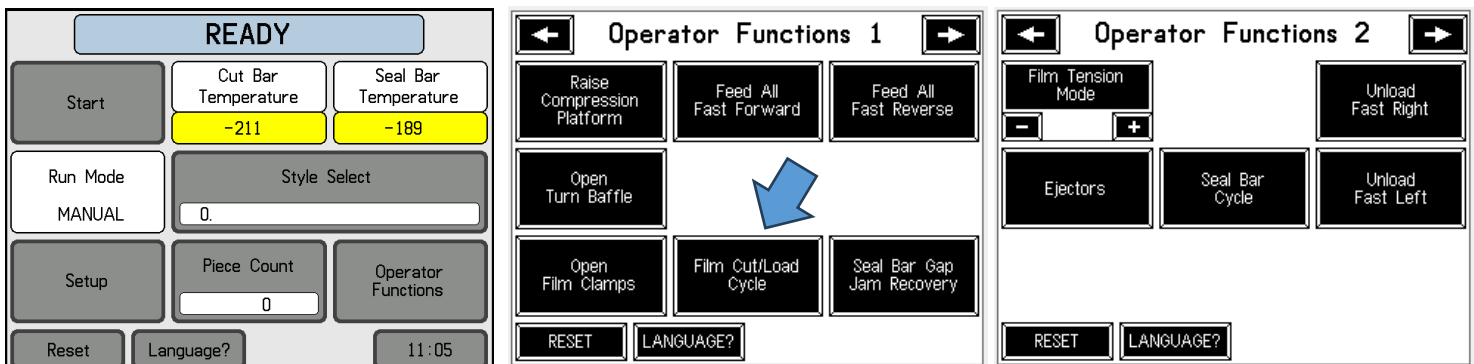

Machine Screens.

The Styles Select Screen is accessed from the Ready Screen.

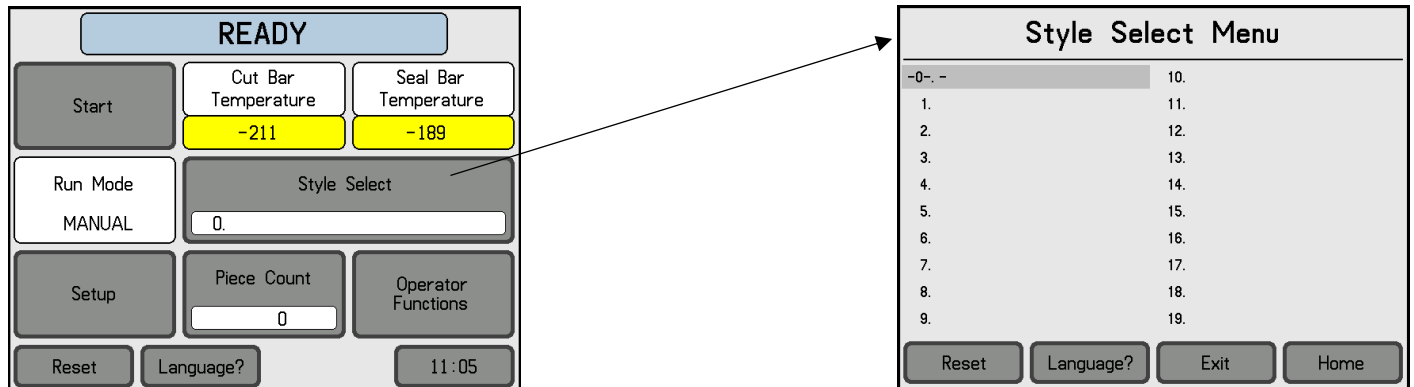

Styles

Accessed on Setup Screen.

Settings for different bed thicknesses and types can be accessed, viewed, and saved.

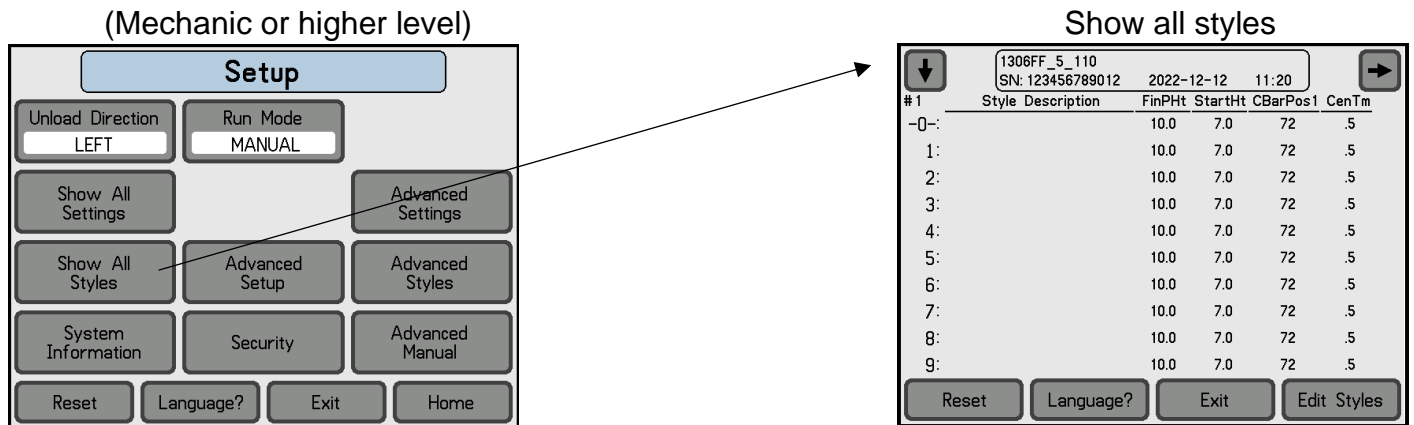

Advanced Styles, pages 1, 2 and 3

Push Style Select Menu to Select Styles

Push Style Edit Menu or Keypad to Edit Styles

Caution: Default Style will return "all" Active Style Settings to factory preset value.

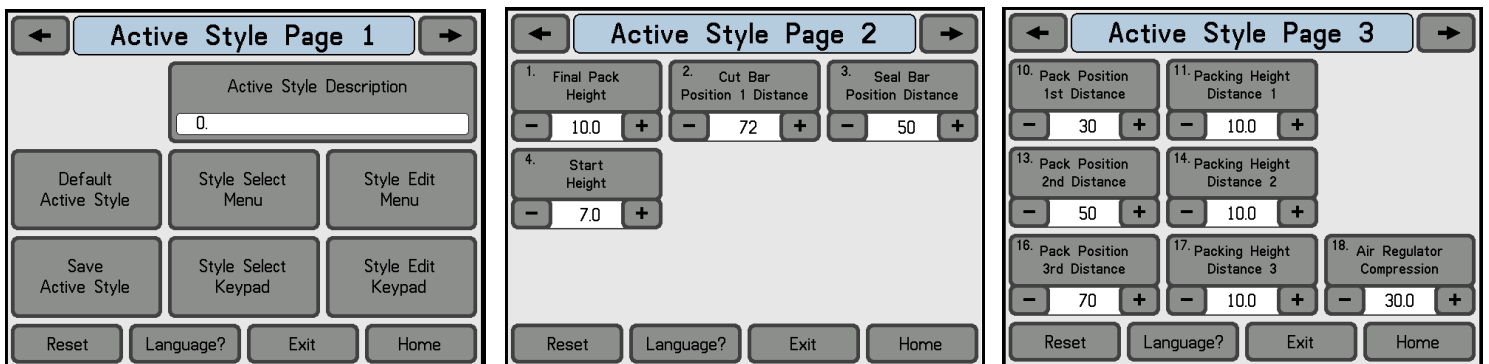

Advanced Settings

(Mechanic or higher level)

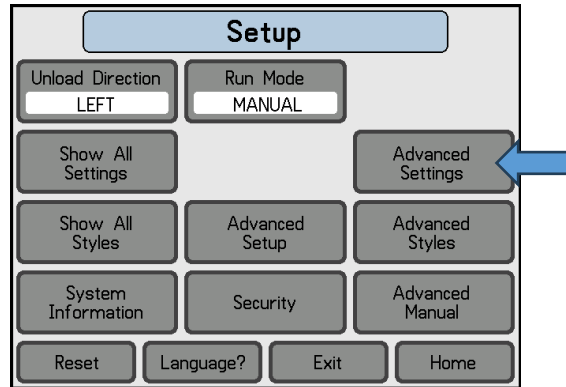

Style Only Settings

Pages 1 - 2

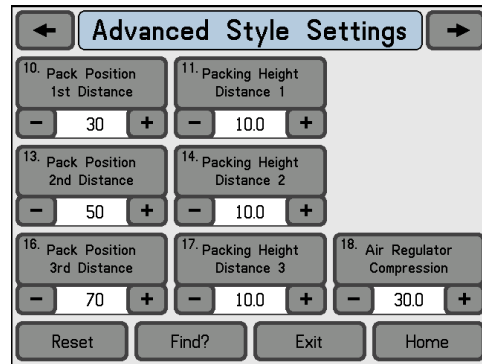
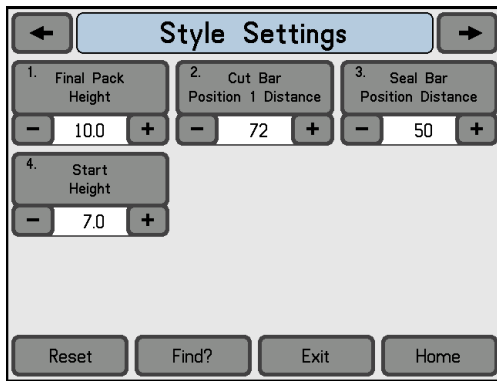

Machine Only Settings

Pages 3, 4 and 5

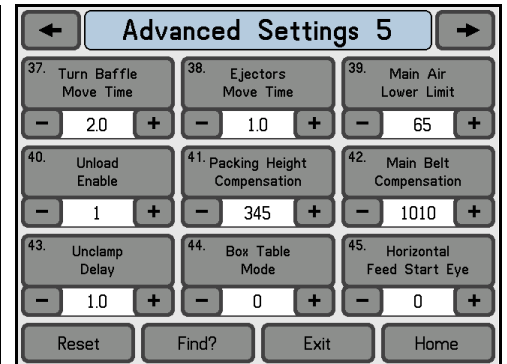
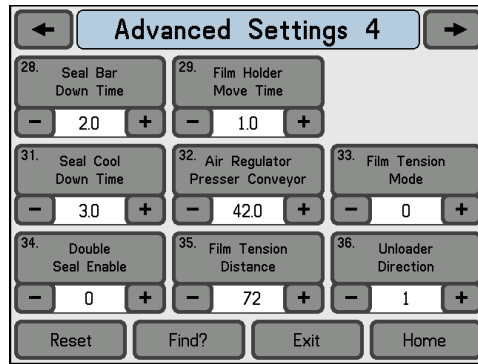
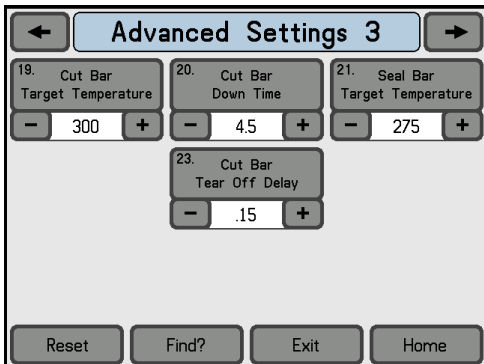

Resetting Piece Count

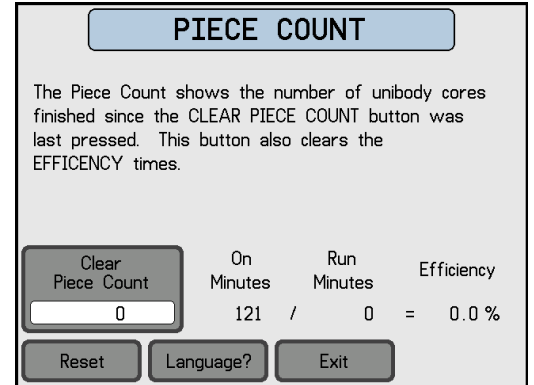
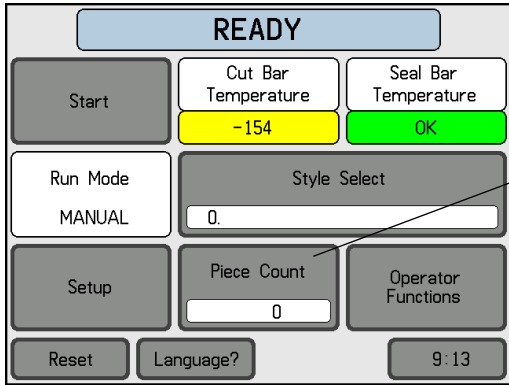

System Information

Accessed on the Setup Screen (Mechanic or higher level)

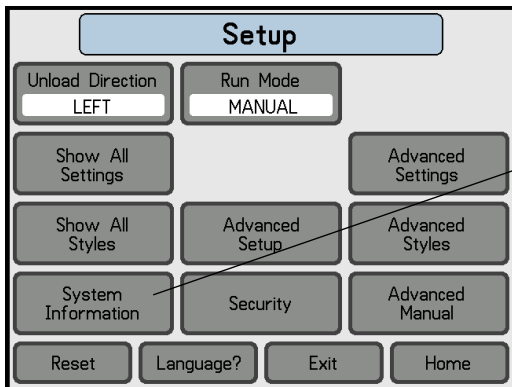

Security Information

Accessed on Setup Screen

Factory Default is set to Operator Level

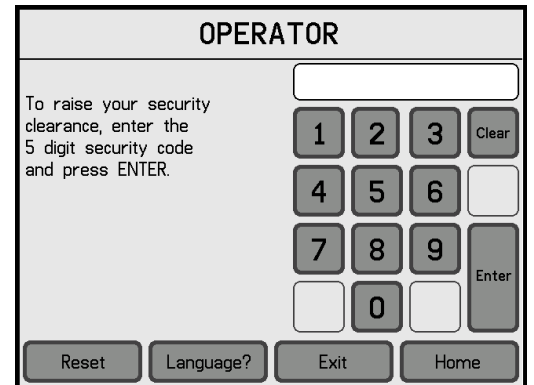
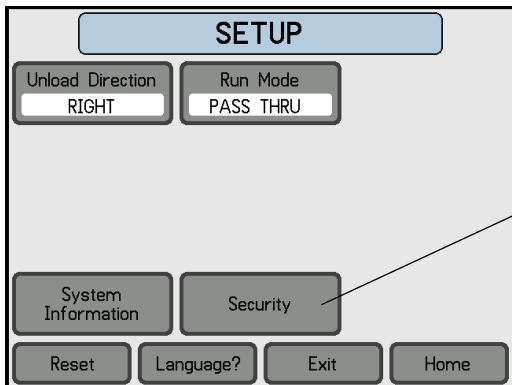

Seal Bar Temperature Settings

Accessed by Advance Settings Page 3
(Mechanic or higher level)

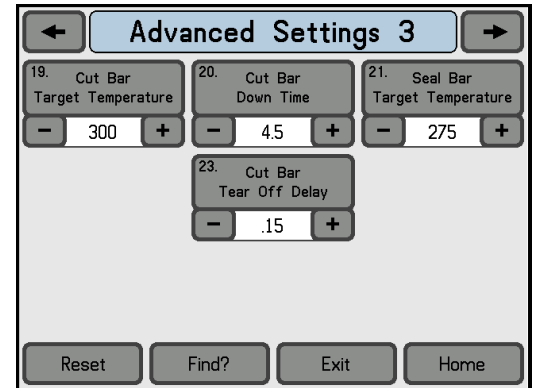
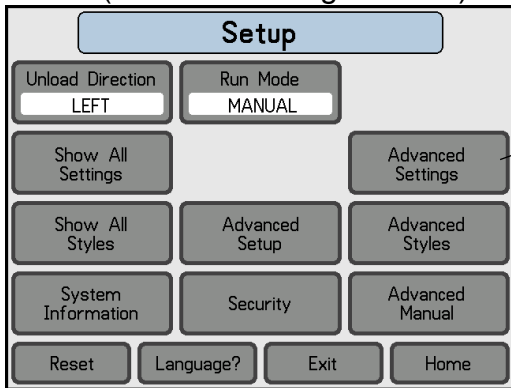

Show All Settings Page

Maintain a copy for backup and future reference

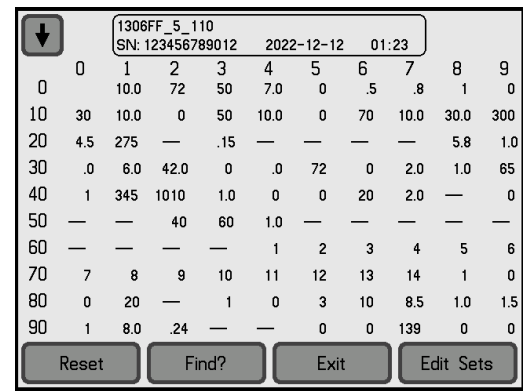
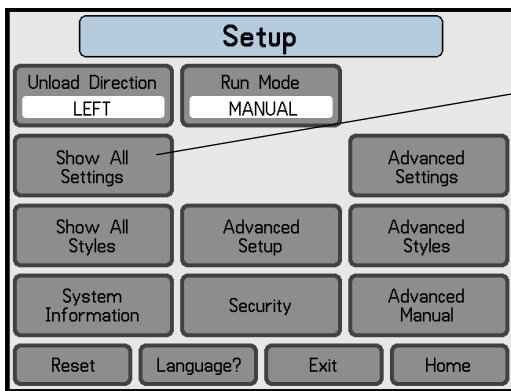

Advanced Manual Information

Accessed on Setup Screen
(Mechanic or higher level)

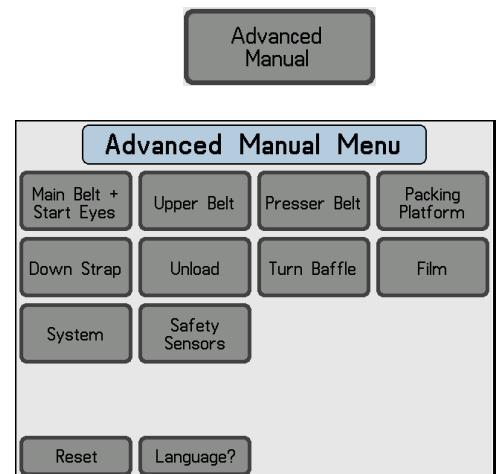
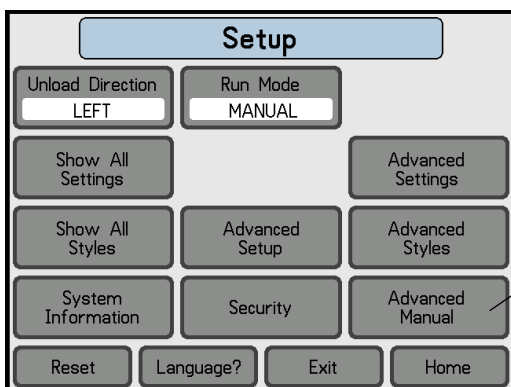

Advanced Manual Continued

Advanced Manual

← ADVANCED MANUAL 1 Main Belt and Start Eyes →

Error code 0	Load % 0	Ch A	Encoder 0"	Ch B
Clear Drive Error	Modbus Retries 188			
Fwd Slow 30.0 Hz	Fwd Fast 80.0 Hz	Pressing Start Eye	Feed Start Eye	
Rev Slow -30.0 Hz	Rev Fast -80.0 Hz	Horiz. Feed Start Eye		
Reset	Language?	Exit		

← ADVANCED MANUAL 2 Upper Belt →

Error code 0	Load % 0			
Clear Drive Error	Modbus Retries 54			
Fwd Slow 30.0 Hz	Fwd Fast 80.0 Hz			
Rev Slow -30.0 Hz	Rev Fast -80.0 Hz			
Reset	Language?	Exit		

← ADVANCED MANUAL 3 Presser Belt →

Error code 0	Load % 0	Presser Down		
Clear Drive Error	Modbus Retries 223			
Fwd Slow 28.6 Hz	Fwd Fast 76.0 Hz			
Rev Slow -28.6 Hz	Rev Fast -76.0 Hz			
Reset	Language?	Exit		

← ADVANCED MANUAL 4 Packing Platform →

Error code 0	Load % 0	Ch A	Encoder 0"	Ch B
Clear Drive Error	Modbus Retries 248			
Hydraulic Pump On 60.0 Hz	Platform Up	Platform Up Limit		
		Platform Down	Platform Down Limit	
Reset	Language?	Exit		

← ADVANCED MANUAL 5 Down Strap →

Error code 0	Load % 0			
Clear Drive Error	Modbus Retries 20			
Fwd Slow 27.5 Hz	Fwd Fast 73.0 Hz			
Rev Slow -27.5 Hz	Rev Fast -73.0 Hz			
Reset	Language?	Exit		

← ADVANCED MANUAL 6 Unload →

Error code 0	Load % 0	Center Trough Eye		
Clear Drive Error	Modbus Retries 12			
Left Slow 30.0 Hz	Right Slow -30.0 Hz	Unload Left Limit	Unload Right Limit	
Left Fast 67.0 Hz	Right Fast -67.0 Hz	Left Boxing Table Down	Right Boxing Table Down	
Reset	Language?	Exit		

← ADVANCED MANUAL 7 Turn Baffle →

Turn Baffle Up On				
Turn Baffle Down On				
Ejectors				
Reset	Language?	Exit		

← ADVANCED MANUAL 8 Film →

Cut Bar Temperature 75.2	Seal Bar Temperature 77.5	Film Out Eye	Film Holder Right Eye
Cut Bar Power	Seal Bar Power	Film Holder Down	Film Holder Left Eye
Cut Bar Down	Seal Bar Drop	Film Holder Down Stop	Film Holder Clamps Open
Film Tension Roller Close			
Reset	Language?	Exit	

← ADVANCED MANUAL 9 System →

Main Air Pressure 0	Red Light		
Air Regulator Pressure - 42 +	Yellow Light	Main Cabinet Fan OK	
Air Regulator Compression - 30 +	Green Light		
Reset	Language?	Exit	

← ADVANCED MANUAL 10 Door Open Safety Switches →

Left Side Front	Safety Pause Warn	Right Side Front		
Left Side Top Left	Rear	Right Side Lower Left	Right Side Top Left	
Left Side Top Right	Right Side Lower Right		Right Side Top Right	
Reset	Language?	Exit		

Compensation:

Packing Height and Main Belt Buttons

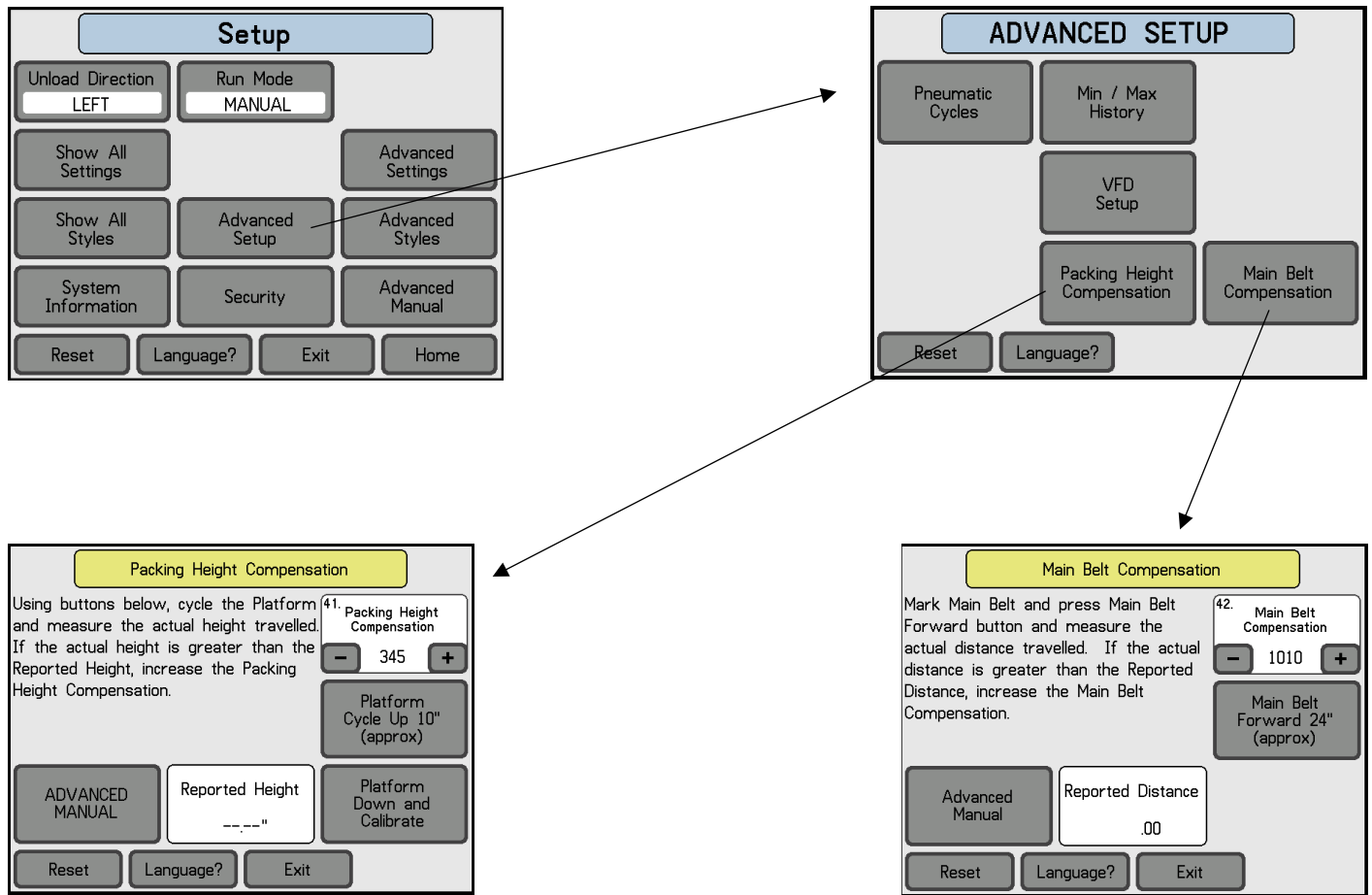

Pneumatic Cycle

Manually cycle all pneumatic components
(Mechanic or higher level)

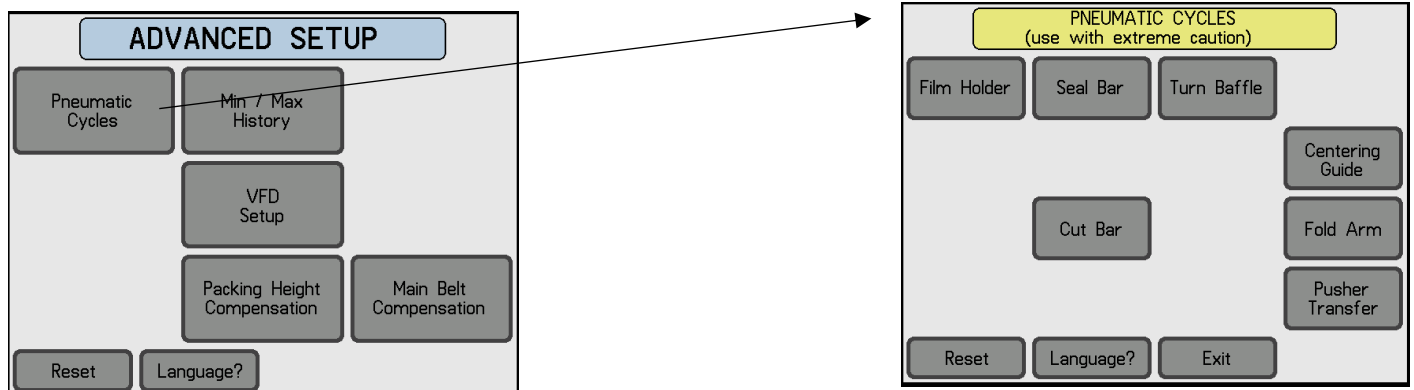

VFD Drive Setup

Accessed on Setup Screen
(Mechanic or higher level)



Vfd Setup

Main Belt	Presser Belt	Upper Belt
Down Strap	Hydraulic Pump	Unload
		Save All Accel/Decel Changes
Reset	Language?	Exit
Home		

Main Belt VFD Setup

120. Main Belt Forward Slow - 30.0 +	121. Main Belt Forward Fast - 80.0 +	122. Main Belt Reverse Slow - -30.0 +
123. Main Belt Reverse Fast - -80.0 +	125. Main Belt Accel - .4 +	
126. Main Belt Decel - .6 +		
Reset	Find?	Exit
Home		

Main Belt Running Test

VFD Enable	Live VFD Error Code 0	Load % 0
Modbus Retries 230	First VFD Error Code 0	Fast Forward
Clear Error		Fast Reverse
Reset	Language?	Exit
Home		

Main Belt Motor / VFD Pairing

Motor Nameplate Volts - 100 +	Motor Nameplate Amps - 1.50 +	Motor Nameplate KWatts - .30 +
Motor Nameplate Power Factor - .60 +	Motor Nameplate RPM - 1600 +	Torque Limit Percent - 30 +
Default Motor Ratings		Pair Main Belt Motor/VFD
Reset	Language?	Exit
Home		

Down Strap VFD Setup

150. Down Strap Forward Slow - 27.5 +	151. Down Strap Forward Fast - 73.0 +	152. Down Strap Reverse Slow - -27.5 +
153. Down Strap Reverse Fast - -73.0 +	155. Down Strap Accel - .4 +	
156. Down Strap Decel - .6 +		
Reset	Find?	Exit
Home		

Down Strap Running Test

VFD Enable	Live VFD Error Code 0	Load % 0
Modbus Retries 20	First VFD Error Code 0	Fast Forward
Clear Error		Fast Reverse
Reset	Language?	Exit
Home		

Down Strap Motor / VFD Pairing

Motor Nameplate Volts - 100 +	Motor Nameplate Amps - 1.50 +	Motor Nameplate KWatts - .30 +
Motor Nameplate Power Factor - .60 +	Motor Nameplate RPM - 1600 +	Torque Limit Percent - 30 +
Default Motor Ratings		Pair Down Strap Motor/VFD
Reset	Language?	Exit
Home		

Presser Belt VFD Setup

130. Presser Belt Forward Slow - 28.6 +	131. Presser Belt Forward Fast - 76.0 +	132. Presser Belt Reverse Slow - -28.6 +
133. Presser Belt Reverse Fast - -76.0 +	135. Presser Belt Accel - .4 +	
136. Presser Belt Decel - .6 +		
Reset	Find?	Exit
Home		

Presser Belt Running Test

VFD Enable	Live VFD Error Code 0	Load % 0
Modbus Retries 20	First VFD Error Code 0	Fast Forward
Clear Error		Fast Reverse
Reset	Language?	Exit
Home		

Presser Belt Motor / VFD Pairing

Motor Nameplate Volts - 100 +	Motor Nameplate Amps - 1.50 +	Motor Nameplate KWatts - .30 +
Motor Nameplate Power Factor - .60 +	Motor Nameplate RPM - 1600 +	Torque Limit Percent - 30 +
Default Motor Ratings		Pair Presser Belt Motor/VFD
Reset	Language?	Exit
Home		

VFD Drives Continued

VFD Setup

Vfd Setup

Main Belt	Presser Belt	Upper Belt
Down Strap	Hydraulic Pump	Unload
		Save All Accel/Decel Changes
Reset	Language?	Exit
Home		

Hydraulic Pump VFD Setup

160. Hydraulic Pump Run	165. Hydraulic Pump Accel		
- 60.0 +	- .8 +		
166. Hydraulic Pump Decel			
- 1.5 +			
Reset	Find?	Exit	Home

Hydraulic Pump Running Test

VFD Enable	Live VFD Error Code	Load %	
	0	0	
Modbus Retries	First VFD Error Code	Run	
143	0		
Clear Error			
Reset	Language?	Exit	Home

Hydraulic Pump Motor / VFD Pairing

Motor Nameplate Volts	Motor Nameplate Amps	Motor Nameplate KWatts	
- 100 +	- 1.50 +	- .30 +	
Motor Nameplate Power Factor	Motor Nameplate RPM		
- .60 +	- 1600 +		
Default Motor Ratings	Pair Hydraulic Pump Motor/VFD		
Reset	Language?	Exit	Home

Upper Belt VFD Setup

140. Upper Belt Forward Slow	141. Upper Belt Forward Fast	142. Upper Belt Reverse Slow	
- 30.0 +	- 80.0 +	- -30.0 +	
143. Upper Belt Reverse Fast	145. Upper Belt Accel		
- -80.0 +	- .4 +		
146. Upper Belt Decel			
- .6 +			
Reset	Find?	Exit	Home

Upper Belt Running Test

VFD Enable	Live VFD Error Code	Load %	
	0	0	
Modbus Retries	First VFD Error Code	Fast Forward	
238	0		
Clear Error			
Fast Reverse			
Reset	Language?	Exit	Home

Upper Belt Motor / VFD Pairing

Motor Nameplate Volts	Motor Nameplate Amps	Motor Nameplate KWatts	
- 230 +	- 5.40 +	- 1.50 +	
Motor Nameplate Power Factor	Motor Nameplate RPM	Torque Limit Percent	
- .78 +	- 1745 +	- 80 +	
Default Motor Ratings	Pair Upper Belt Motor/VFD		
Reset	Language?	Exit	Home

Unload VFD Setup

170. Unload Left Slow	171. Unload Left Fast	172. Unload Right Slow	
- 30.0 +	- 67.0 +	- -30.0 +	
173. Unload Right Fast	175. Unload Accel		
- -67.0 +	- .8 +		
176. Unload Decel			
- .2 +			
Reset	Find?	Exit	Home

Unload Running Test

VFD Enable	Live VFD Error Code	Load %	
	0	0	
Modbus Retries	First VFD Error Code	Fast Left	
201	0		
Clear Error			
Fast Right			
Reset	Language?	Exit	Home

Unload Motor / VFD Pairing

Motor Nameplate Volts	Motor Nameplate Amps	Motor Nameplate KWatts	
- 100 +	- 1.50 +	- .30 +	
Motor Nameplate Power Factor	Motor Nameplate RPM		
- .60 +	- 1600 +		
Default Motor Ratings	Pair Unload Motor/VFD		
Reset	Language?	Exit	Home

Run Modes

Accessed on Setup Page(Mechanic or higher level)

Manual Mode

Use only to manually step through the rolling process

Setup			
Unload Direction LEFT	Run Mode MANUAL		
Show All Settings		Advanced Settings	
Show All Styles	Advanced Setup	Advanced Styles	
System Information	Security	Advanced Manual	
Reset	Language?	Exit	Home

Automatic Modes

Mode 1 -4: used to preset all processes for styles

Setup			
Unload Direction LEFT	Run Mode AUTOMATIC 1		
Show All Settings		Advanced Settings	
Show All Styles	Advanced Setup	Advanced Styles	
System Information	Security	Advanced Manual	
Reset	Language?	Exit	Home

Pass Thru Mode:

Allows product pass through without rolling up

Setup			
Unload Direction LEFT	Run Mode PASS THRU		
Show All Settings		Advanced Settings	
Show All Styles	Advanced Setup	Advanced Styles	
System Information	Security	Advanced Manual	
Reset	Language?	Exit	Home

Unload Direction:

Allows left or right unloading

Setup			
Unload Direction RIGHT	Run Mode MANUAL		
Show All Settings		Advanced Settings	
Show All Styles	Advanced Setup	Advanced Styles	
System Information	Security	Advanced Manual	
Reset	Language?	Exit	Home

Machine Sequence

Pressing the start button on the Ready Page will put the machine in automatic mode.

Understanding the effects of the settings. (Cont'd)

Step 1. The press platform lowers to the lower limit and resets the press position counter then rises to the **Packing Height Load Distance** setting. The machine is active and awaiting a mattress to begin a rolling cycle.

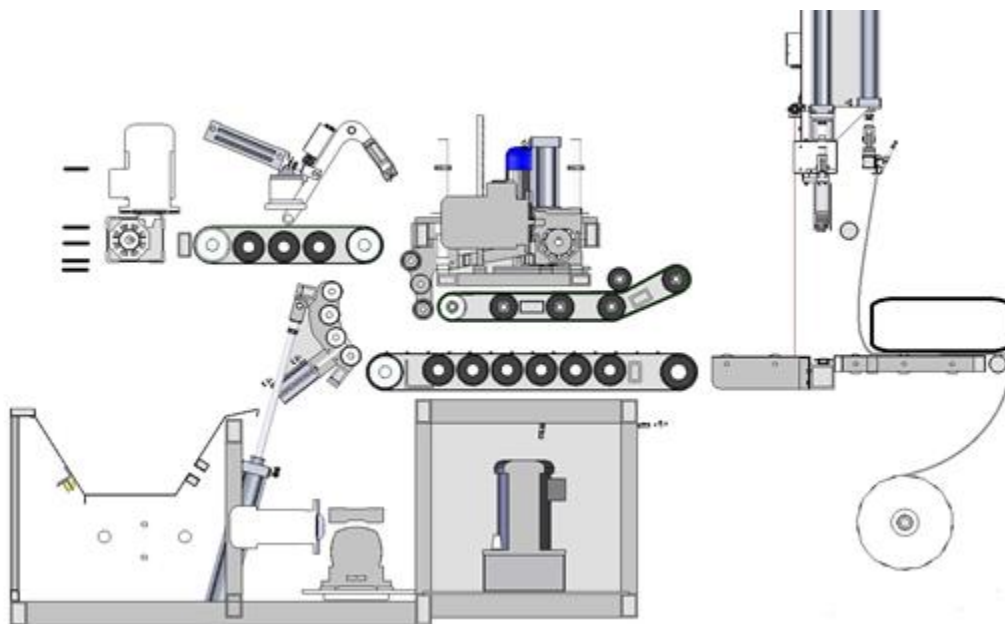

Step 2. The operator pushes the mattress into the loading table until the feed start sensor is blocked and the plastic is released. The conveyors begin to move in anticipation of the mattress to be rolled.

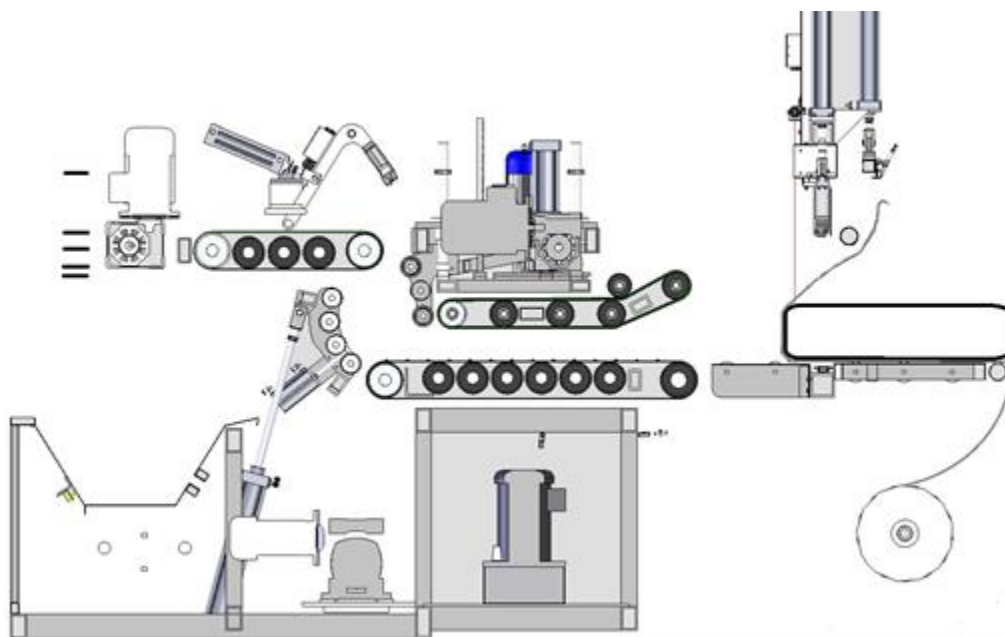

Step 3. The mattress is pushed into the conveyor belts and the conveyors draw the mattress towards the rolling chamber. The mattress is released by the operator at this time.

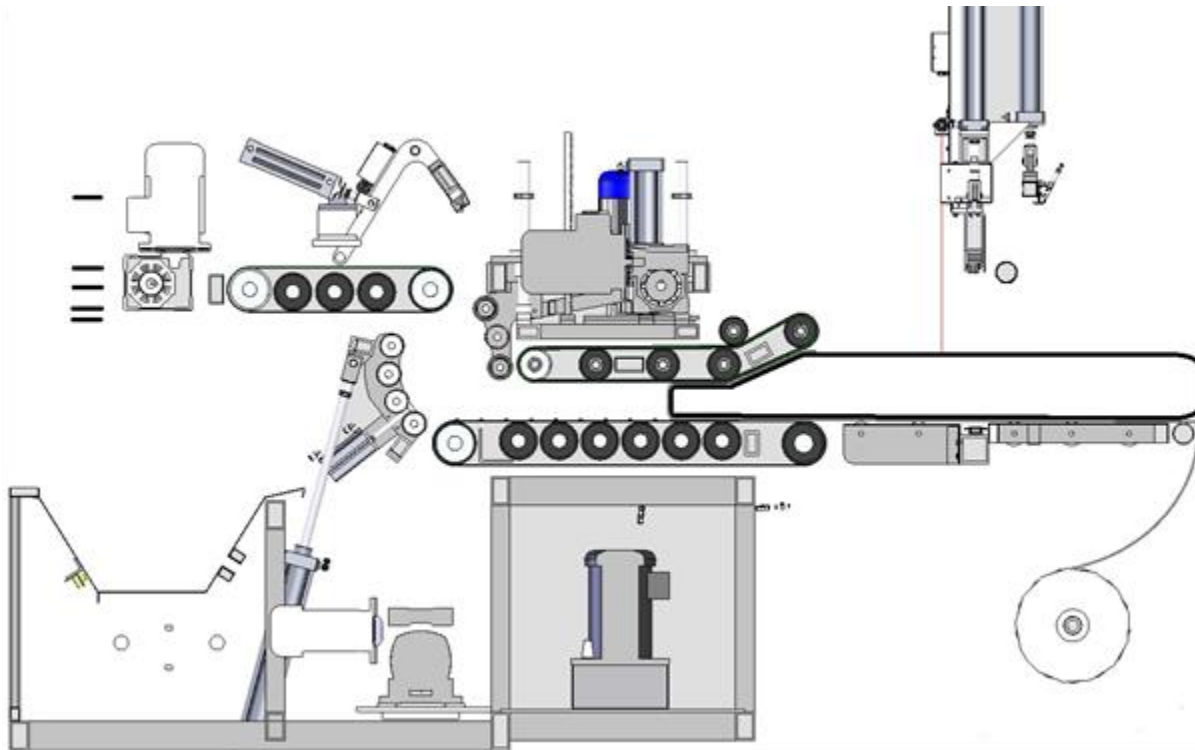

Step 4. The Pressing start sensor is blocked and pressing belt is lowered to the **Air Regulator Pressing Conveyor** setting. The Platform moves to the **Pressing Height Distance 1** setting. The Pack Position counter is reset to zero and the conveyor begins moving towards **Pack Position Distance 1**(Advanced Settings).

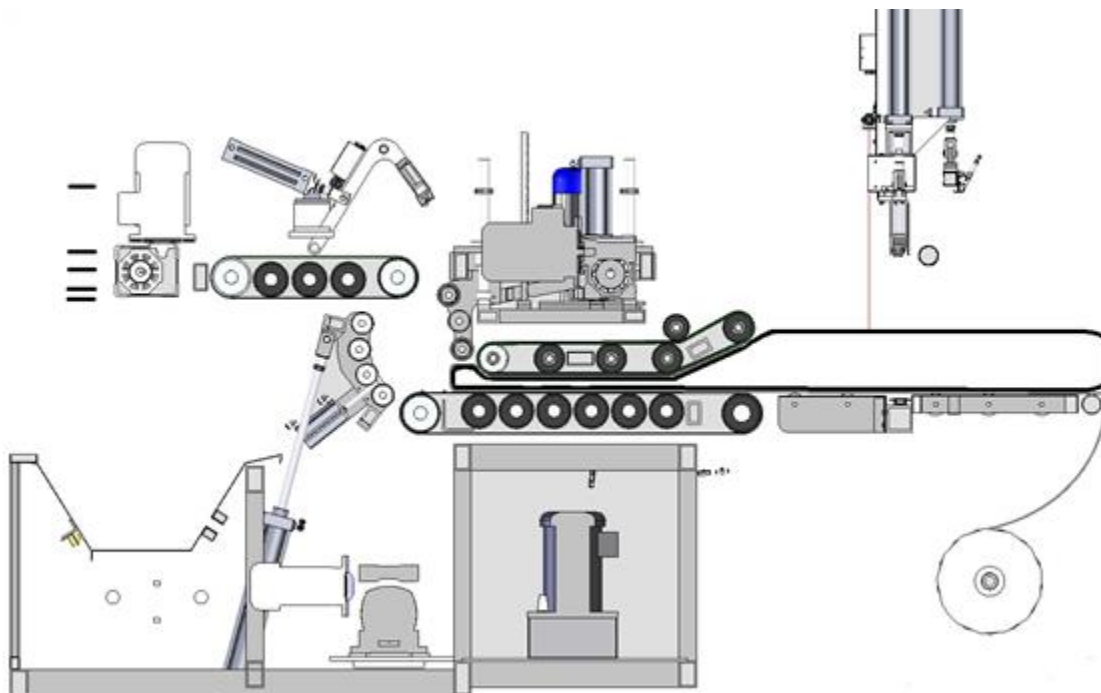

Step 5. The conveyor begins to feed the compressed mattress into the rolling chamber. As the roll becomes more compressed, the platform shifts to the left to maintain the **Air Regulator Compression** setting

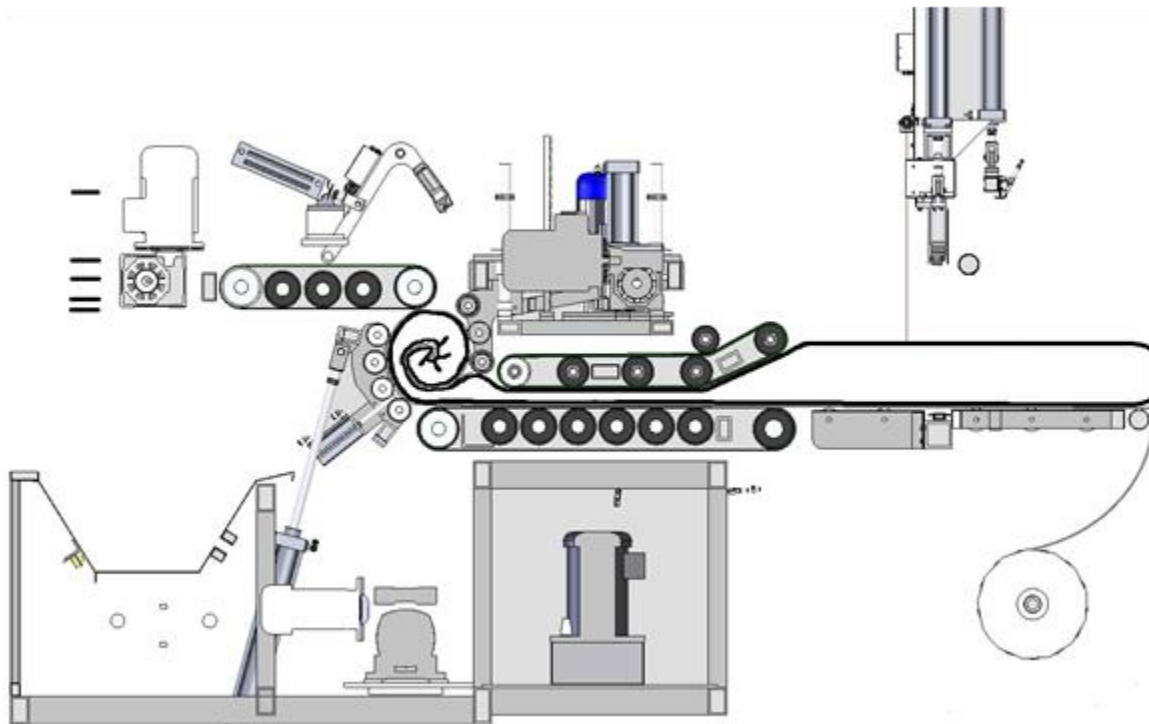

Step 6. The conveyor continues to feed the compressed mattress into the rolling chamber. **Pack Position Distance 1**(Advanced Settings) is met and the pressing platform indexes to the Packing Height Distance 2 position. The machine begins moving towards the **Pack Position Distance 2**(Advanced Settings) position.

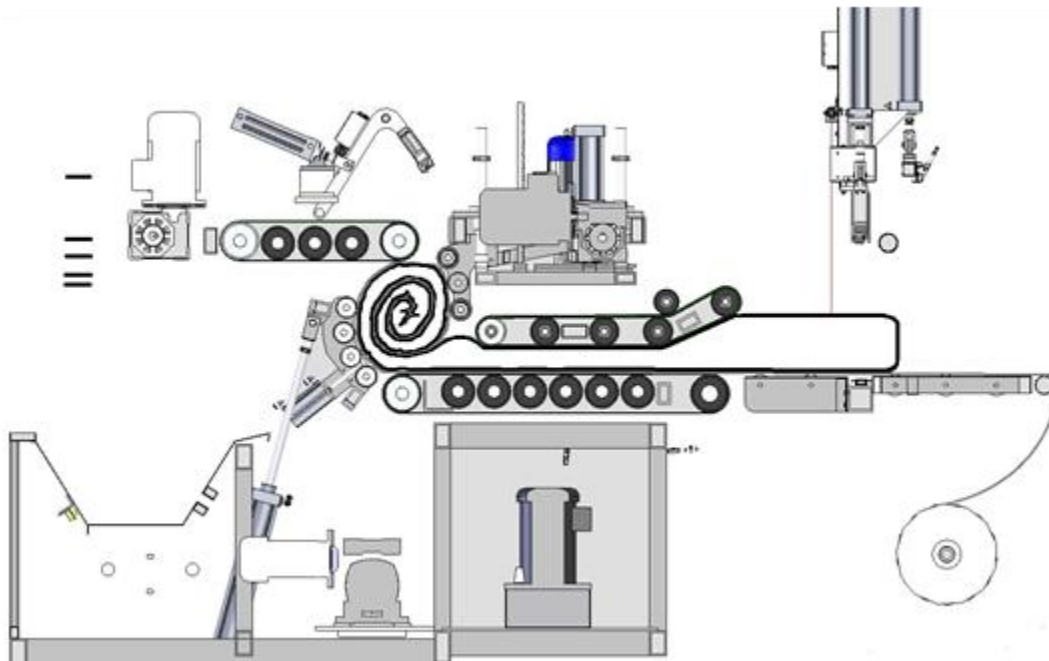

Step 7. The feed start sensor is unblocked and the machine resets the cut bar distance counter. The machine begins counting the **Cut Bar Distance** setting.

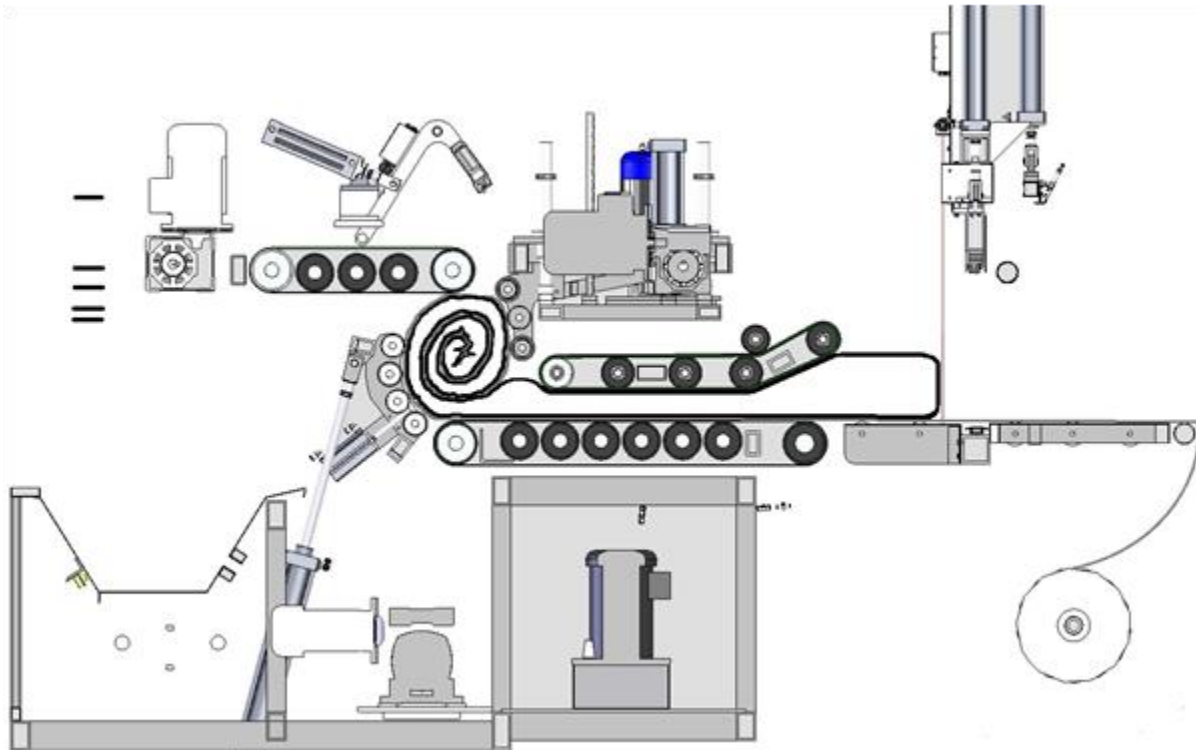

Step 8. the **Pack Position Distance 2**(Advanced Settings) position is met, and the platform moves to the **Packing Height Distance 3** position.

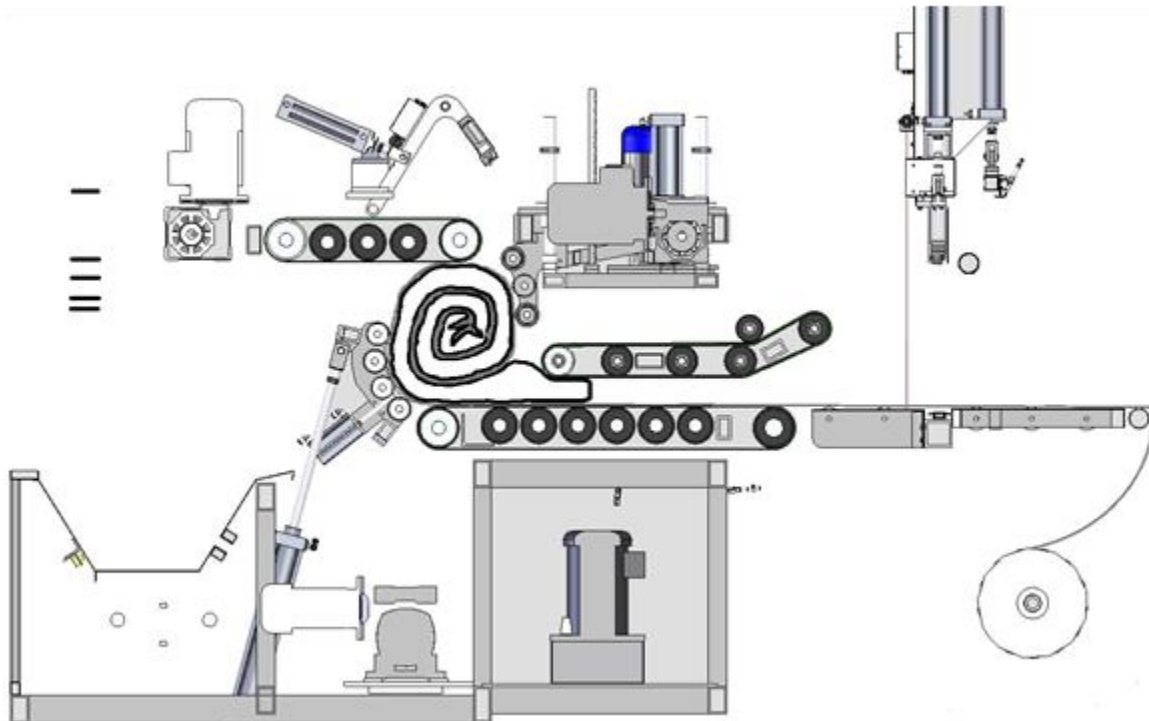

Step 9. The **Cut Bar Distance** setting is met, and the cut bar and plastic gripper descend to cut the final wrap of plastic used to roll the mattress. The seal bar position counter is reset, and the **Seal Bar Position Distance** setting begins to be counted.

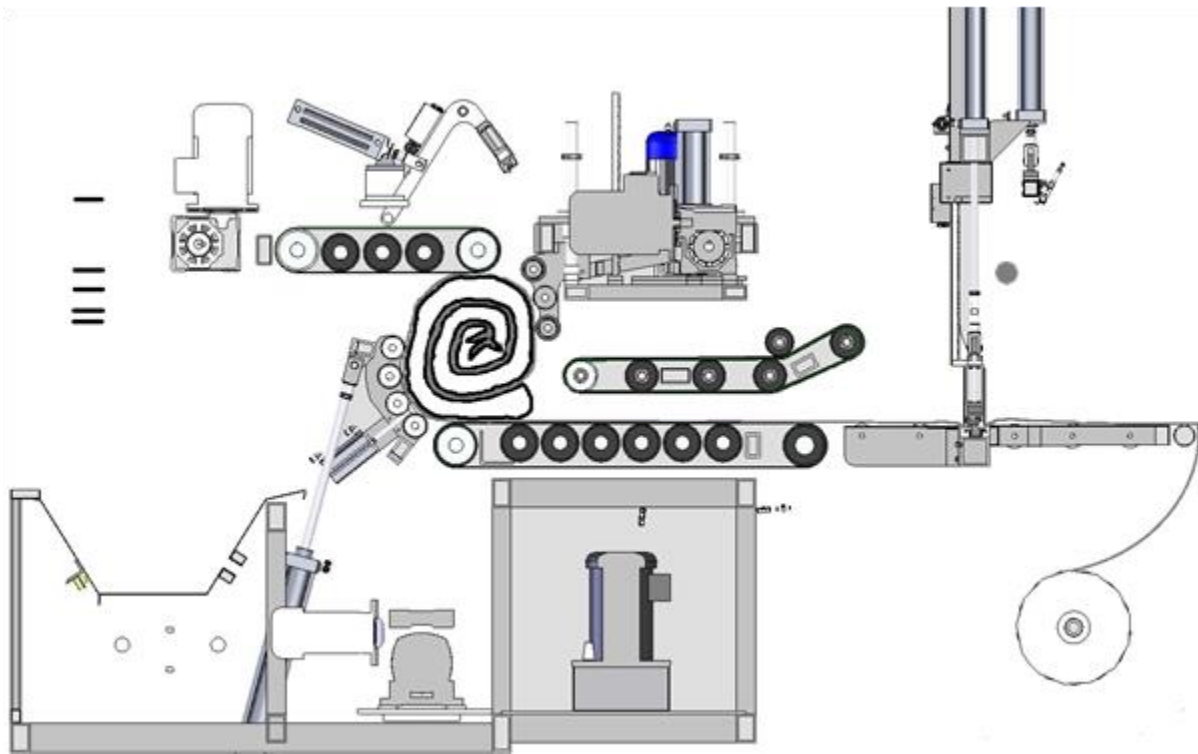

Step 10. The **Seal Bar Position Distance** setting is met, and the seal bar descends to do the final seal of the mattress roll. The seal bar travels and dwells for the duration of the **Seal Bar Down Time** setting before retracting.

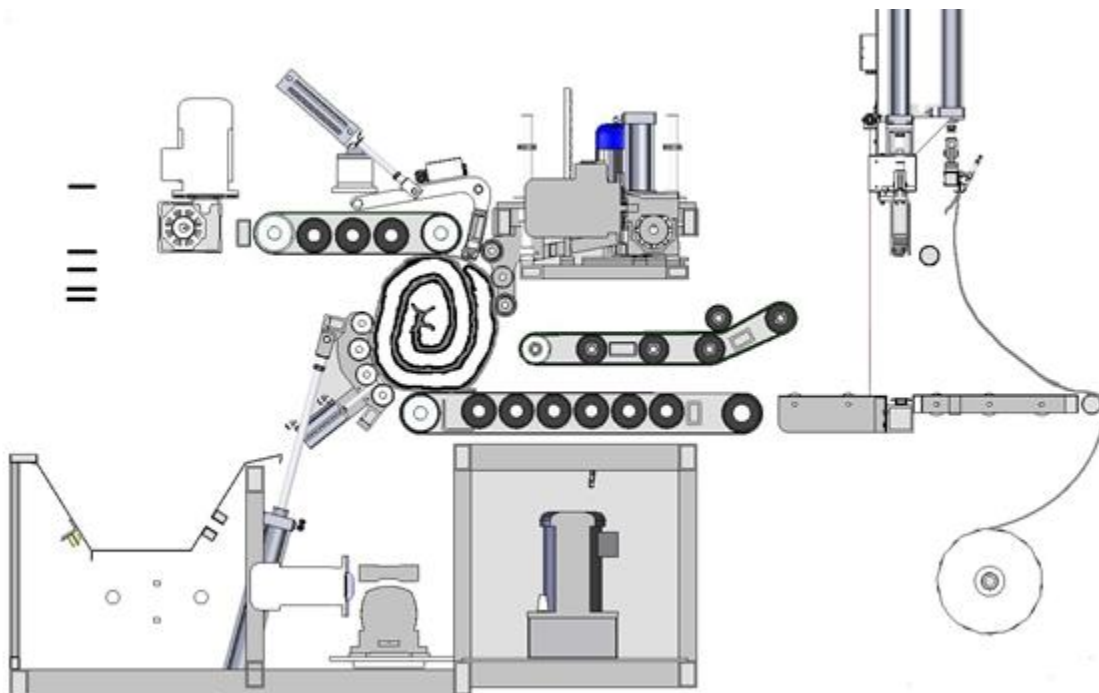

Step 11. The platform moves to the platform upper limit position and lowers the turn baffle to eject the mattress roll.

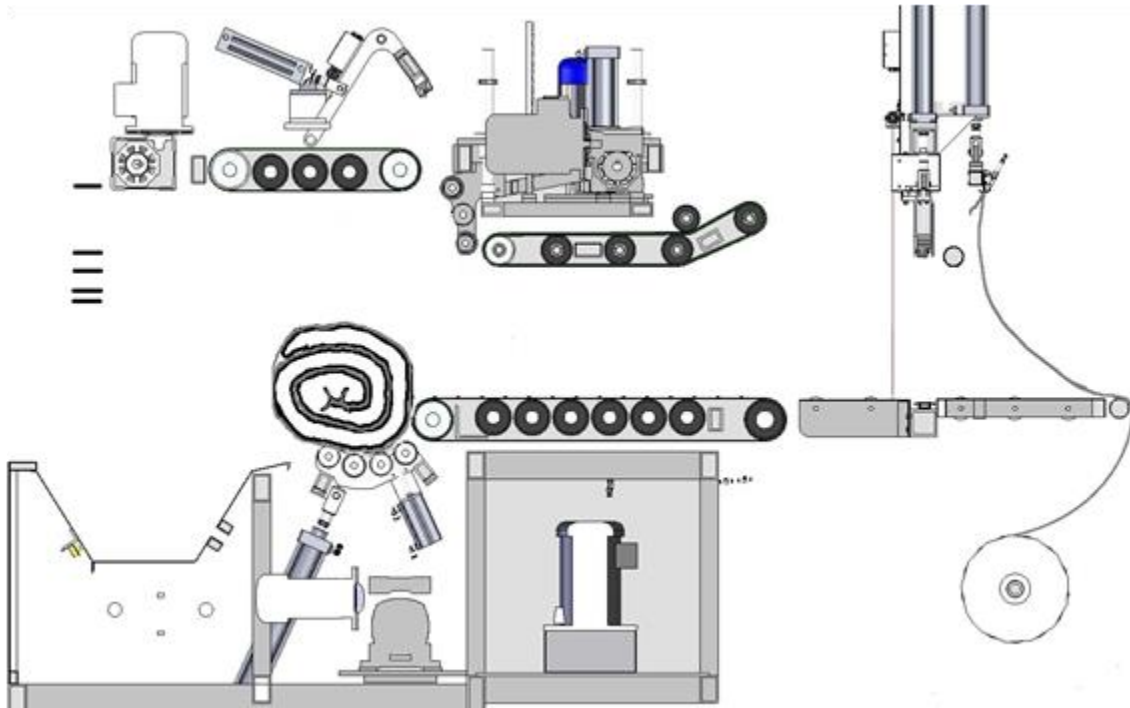

Step 12. If the unload sensor has not been met, then the ejector finger fire to eject the roll from the turn baffle. The unload conveyor is cycled, and the finished roll is ejected from the side of the machine. The cycle is complete, and the machine returns to step 1.

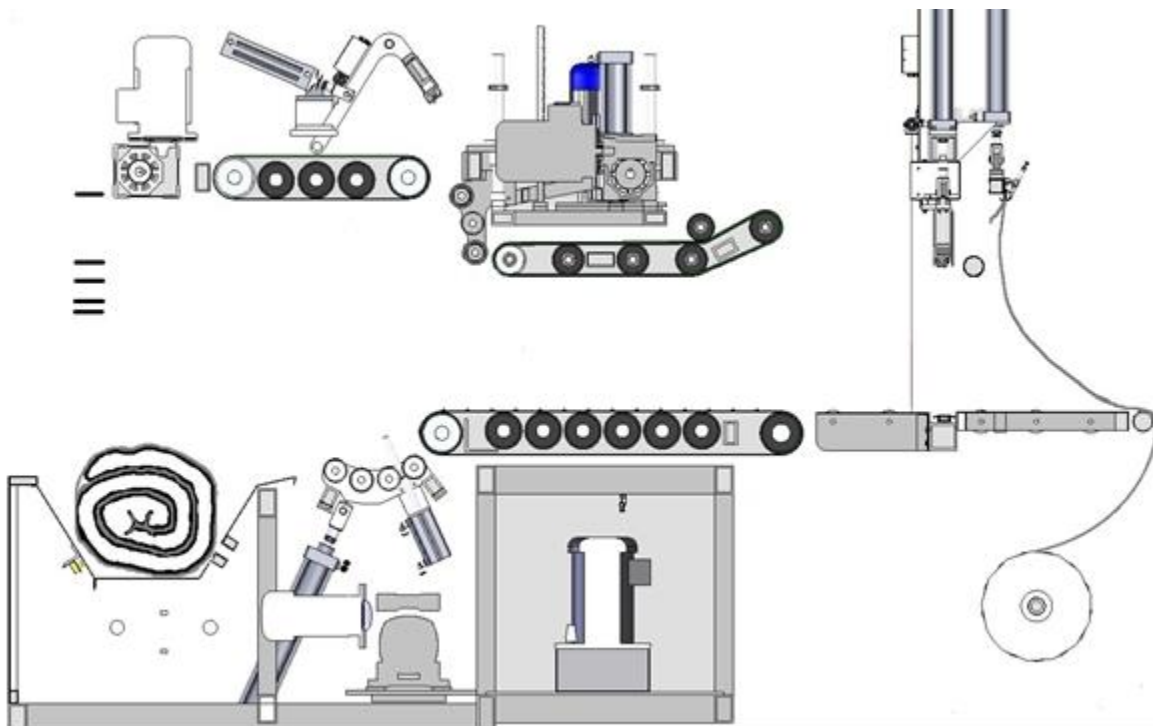

2.2. Machine Operation

Machine Start Up

1. Turn main power disconnect switch to ON position.
2. Turn Main Air Valve to the ON position.
The pressure on the gauge should be set to 90 PSI.
3. Ensure all E-Stops are disengaged on all 4 corners of the machine.
4. Press the Green Power button Located on any of the four E-Stop Boxes.



NOTE: Machine will move during power up. It is the operator's responsibility to make sure the machine is clear before initiating power on.

The seal bars will begin to heat up at this point. It takes approx. 30 minutes for the heated bars to come up to temperature and stabilize.

6. When the target temperatures have been reached on both bars and are staying within 5 degrees of the set point for 5 minutes, both temperature buttons will display a green "OK"

Example below displays a yellow "low temperature state"

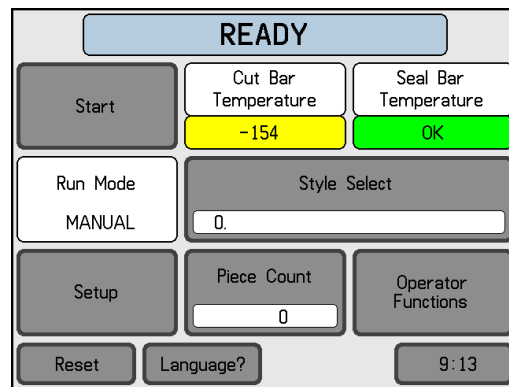

6. Press the Start button to enter automatic operation.
If the machine is not up to temperature, the temp error screen will be displayed and pressing the reset button will return you to the temperature monitor screen.
7. The ready to run screen will be displayed indicating the machine is ready to receive a mattress to roll.
8. Push mattress into plastic curtain in front of the loading table.
9. Machine will release plastic when the feed start sensor eye is block. Continue pushing Mattress till engaged in pressing conveyor.
10. Watch rolling sequence during first roll of new product to ensure the correct settings have been selected. Always be ready to hit the e-stop or pause the cycle to ensure product is not damaged during an improper feed and roll cycle.

General Instructions

It is important that the machine operator read this manual and is familiar with all the functions and safety concerns of the unit before operating.



2.3. General Operation

ATTENTION: DO NOT USE ANY SHARP OBJECTS TO TOUCH THE SCREEN

The graphics images presented on the touch screen show "3-dimensional" buttons, which may be pressed to access other screens, change counters and timers, or actuate hardware. Areas lacking the "3- dimensional" border contain information only.

Counters are identified with the "+" and "-" buttons in the corners. These counters may be adjusted by touching the "+" and "-" boxes.

RESET: Clears all machine functions and returns to the main page. time and date.

LANGUAGE: Return to the language screen. You can select multiple languages to use.

HOME: Return to the main screen.

EXIT: Return to previous page

ARROWS: Pressing the arrows right or left will take you to the next or previous pages.

NOTES: When a button has a white background, the function is on or enabled. A dark background indicates off or disabled. Some buttons may toggle on or off, others must be held on.



Advanced Settings Access Code:

Other screens display whenever there is a machine error or other condition that prohibits the operation of the machine. Simply follow the instruction on the screens to resolve the problem. There are also "ADVANCED" settings and functions available. These functions are only accessible by a password, and include timers that control machine hardware, input and output test screens, and machine statistics. To get to the advanced functions the appropriate password must be entered at the security screen. Security access is reset whenever the main power is turned off, or the RESET button on the main page is pressed.

The factory default access code is "33333".

Available Menus

The following is a summary of functions available for the Machine Operator.

1306F – Main Screen

The normal operation of the machine is controlled from the main 1306FF – READY screen. From here you can start the automatic cycle and access all machine functions.

START: After touching this field the machine automatic function of the roll pack is activated. When this button is pressed, the operator is brought to the “WAITING TO LOAD” screen.

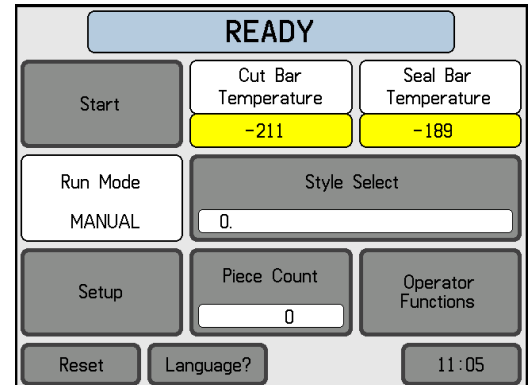

LANGUAGE: This field is in almost all the available screens. Select at any time to access other languages.

ADVANCED STYLES: main setting screen with set-up for rolling the current mattress. See section “” for more details about this screen.



EDIT NEW ORDER: See a section in this book with more details about this screen.

ADVANCED SETUP: Area reserved only for mechanics or technicians



ADVANCED MANUAL: Area reserved only for mechanics and higher security. This contains means to move different parts of the machine for troubleshooting and maintenance purposes.



PIECE COUNT: The field on the left of the clock button is the piece counters that increment every time the border cycle is complete. Touching on this area will bring up a screen to reset this count. This counter can be used for a daily production monitor. On this screen is also located an efficiency monitor that displays the machine run time vs. the machine on time and displays it as a percentage.

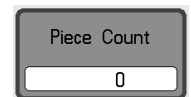

CLOCK: Lower right button allows access to a screen for setting the correct time.

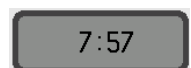

Ready to Load Screen.

Operator can begin automatic rolling from this screen. Accessed by pressing start from the main screen while machine is up to temperature.

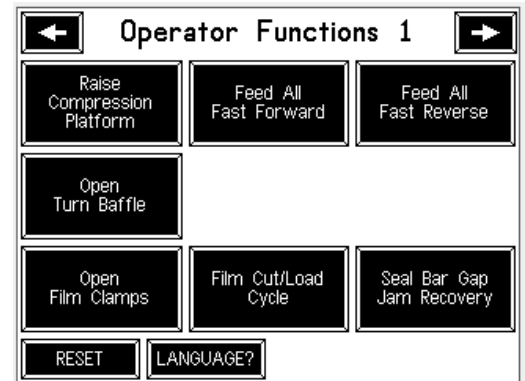
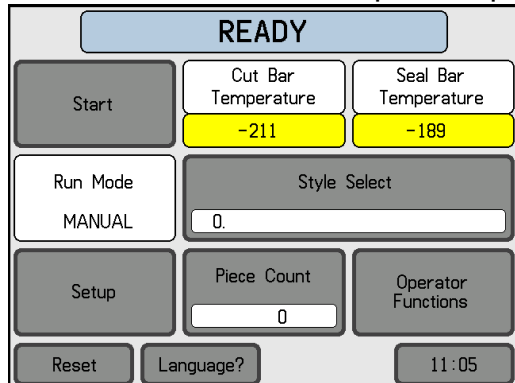

FILM LOAD CYCLE:

This button actuates the plastic gripper bar to lower and grab the wrapping plastic.



NOTE: Be sure hazard tapped area of in-feed table surface is clear of foreign objects and/or body parts before pressing this button.

Advanced Functions

This screen allows access to SECURITY, SYSTEM INFORMATION, SHOW ALL SETTINGS, ADVANCED SETUP, MANUAL,

Note: These screens are restricted areas for Mechanics or Technicians; they can only be accessed using a password.

SECURITY button accesses the security screen for changing the pass codes. Contact an Atlanta Attachment technician for instructions on changing the pass code

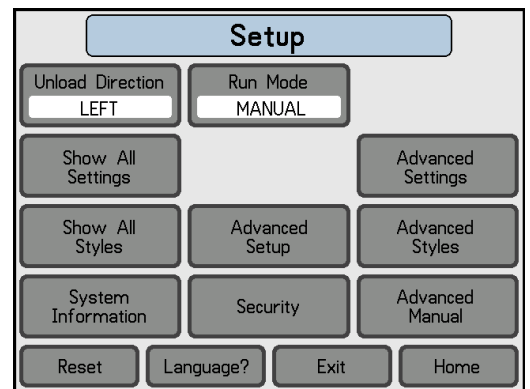

SHOW ALL SETTINGS page displays all machine settings as a matrix. Use this screen for recording all settings prior to a program update or for reference.

Special Note: All settings should also be written down in case of a module failure or an update that would require the memory module to be defaulted. The styles settings are not backed up and all settings will be lost in the case of a memory module fault. These settings differ from manufacturer to manufacturer, and they are for reference only as every mattress rolls differently.

Atlanta Attachment cannot be responsible for loss of settings due to updates. Below are starting points for settings.

	1306FF_5_110									
	SN: 123456789012 2022-12-12 01:23									
	0	1	2	3	4	5	6	7	8	9
0	10.0	72	50	7.0	0	.5	.8	1	0	
10	30	10.0	0	50	10.0	0	70	10.0	30.0	300
20	4.5	275	—	.15	—	—	—	—	5.8	1.0
30	.0	6.0	42.0	0	.0	72	0	2.0	1.0	65
40	1	345	1010	1.0	0	0	20	2.0	—	0
50	—	—	40	60	1.0	—	—	—	—	—
60	—	—	—	—	1	2	3	4	5	6
70	7	8	9	10	11	12	13	14	1	0
80	0	20	—	1	0	3	10	8.5	1.0	1.5
90	1	8.0	.24	—	—	0	0	139	0	0

Style Editing

Detailed Method

With Descriptions of each Setting(Mechanic or higher level)

Press Setup Button on Ready/Home screen

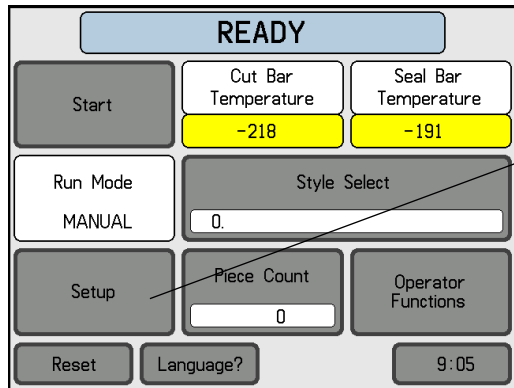

Press Advanced Styles Button

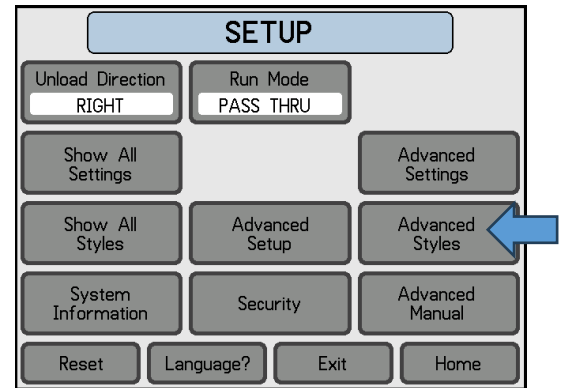

Press Right Arrow Button for Page 2 or 3

Locate & Press Setting# for change

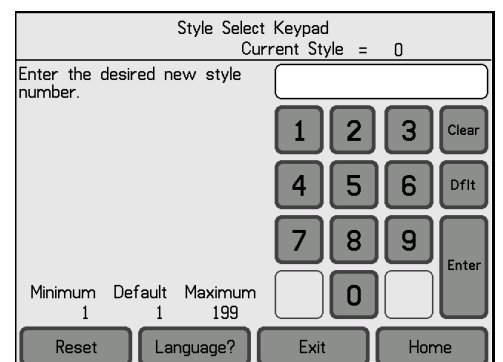
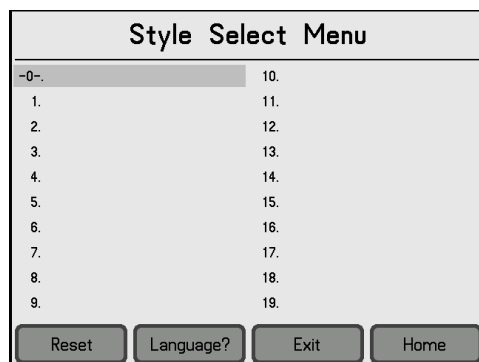
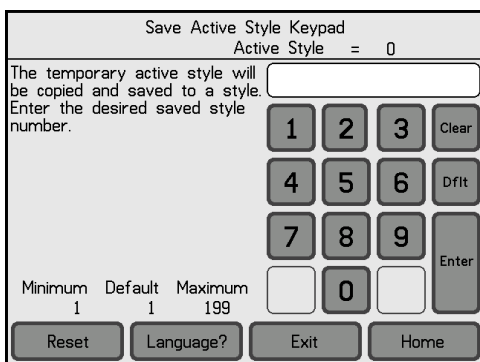
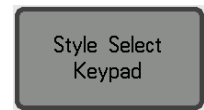
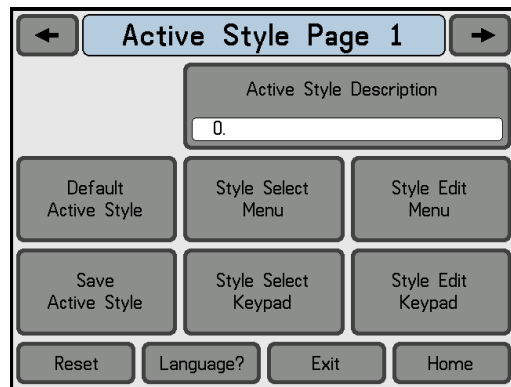

Style Edit Menu

EDIT STYLES MENU

#1	Style Description	FinPHt	StartHt	CBarPos1
-0-		10.0	7.0	72
1:		10.0	7.0	72
2:		10.0	7.0	72
3:		10.0	7.0	72
4:		10.0	7.0	72
5:		10.0	7.0	72
6:		10.0	7.0	72
7:		10.0	7.0	72
8:		10.0	7.0	72
9:		10.0	7.0	72

Reset Language? Exit Home

Style Edit Keypad

Edit Style Keypad
Active Style = 0

Enter the desired style number to be edited.

1 2 3 Clear
4 5 6 Drft
7 8 9 Enter
0

Minimum 1 Default 1 Maximum 199

Reset Language? Exit Home

Active Style Description

0. -

← ← Bck Clr → →

., -

@ # % * () - + / =
0 1 2 3 4 5 6 7 8 9
q w e r t y u i o p
a s d f g h j k l Cap
z x c v b n m . ? Spc

Reset Language? Exit Abort

Press left or right arrow button to access # 1 -18 settings for Position, Height, Seal and Cut

← Active Style Page 2 →

1. Final Pack Height
- 10.0 +

2. Cut Bar Position 1 Distance
- 72 +

3. Seal Bar Position Distance
- 50 +

4. Start Height
- 7.0 +

Reset Language? Exit Home



← Active Style Page 3 →

10. Pack Position 1st Distance
- 30 +

11. Packing Height Distance 1
- 10.0 +

13. Pack Position 2nd Distance
- 50 +

14. Packing Height Distance 2
- 10.0 +

16. Pack Position 3rd Distance
- 70 +

17. Packing Height Distance 3
- 10.0 +

18. Air Regulator Compression
- 30.0 +

Reset Language? Exit Home

Press the top of the button for explanation of settings and + / - to change number value

↓

2. Cut Bar Position 1 Distance

← - 72 + →

Final Pack Height(1)

1. Final Pack Height

100

This number defines the final size of the rolling chamber. This distance must be at least as high as the Roll Cage Minimum Height

Units: inches

Min, Typical, Max values: 8.5, 10.0, 23.0

Reset Language? Exit Home

Cut Bar Position(2)

2. Cut Bar Position 1 Distance

72

This distance controls how far the machines feeds past the trailing edge of the bed in order to cut the film at the appropriate length for one wrap.

Units: inches

Min, Typical, Max values: 0, 72, 300

Reset Language? Exit Home

Seal Bar Position(3)

3. Seal Bar Position Distance

50

This setting is the distance that the machines feeds after the trailing edge film cut till the feeding stops for the sealing cycle.

Units: inches

Min, Typical, Max values: 0, 50, 300

Reset Language? Exit Home

Start Height(4)

4. Start Height

7.0

This the height of the infeed conveyors at start. This value determines the space between infeed belts.

Units: inches

Min, Typical, Max values: 1.0, 7.0, 26.0

Reset Language? Exit Home

Air Regulator, Compression(18)

18. Air Regulator - Compression

30.0

This setting controls the amount of air pressure applied to the roll during the rolling process in a lateral direction.

Min, Typical, Max values: .0, 30.0, 90.0

Reset Language? Exit Home

Pack Position 1st(10)

10. Pack Position Distance 1

30

This setting is how far the leading edge of the mattress must feed past the Pressing Start Eye before the Platform moves up to the Pack Height 2 position.

Units: inches

Min, Typical, Max values: 10, 30, 200

Reset Language? Exit Home

Pack Position 2nd(13)

13. Pack Position Distance 2

50

This setting is how far the leading edge of the mattress must feed past the Pressing Start Eye before the Platform moves up to the Pack Height 3 position.

Units: inches

Min, Typical, Max values: 30, 50, 200

Reset Language? Exit Home

Pack Position 3rd(16)

16. Pack Position Distance 3

70

This setting is how far the leading edge of the mattress must feed past the Pressing Start Eye before the Platform moves up to the final Pack Height position.

Units: inches

Min, Typical, Max values: 50, 70, 200

Reset Language? Exit Home

Packing Height 1st(11)

11. Pack Height Distance 1

100

This setting is how high the Platform moves up when the leading edge of the mattress feeds to the Pressing Start Eye.

This distance must be at least as high as the Roll Cage Minimum Height

Units: inches

Min, Typical, Max values: 8.5, 10.0, 23.0

Reset Language? Exit Home

Packing Height 2nd(14)

14. Pack Height Distance 2

100

This setting is how high the Platform moves up when the leading edge of the mattress feeds past the Pressing Start Eye by the Pack Position Distance 1.

This distance must be at least as high as the Roll Cage Minimum Height

Units: inches

Min, Typical, Max values: 8.5, 10.0, 23.0

Reset Language? Exit Home

Packing Height 3rd(17)

17. Pack Height Distance 3

100

This setting is how high the Platform moves up when the leading edge of the mattress feeds past the Pressing Start Eye by the Pack Position Distance 2.

This distance must be at least as high as the Roll Cage Minimum Height

Units: inches

Min, Typical, Max values: 8.5, 10.0, 23.0

Reset Language? Exit Home

Exiting Page 2 will return you to Page 1>>Press Save Active Style Button >Use keypad to Enter Style Number you were making changes to and want to Save those changes.

Be sure the Style Number is displayed, if not use keypad to enter and then Press Enter to Save settings.

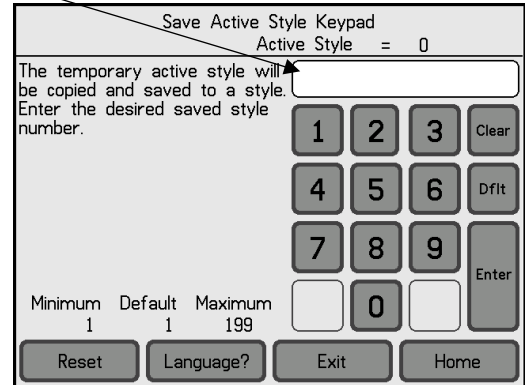
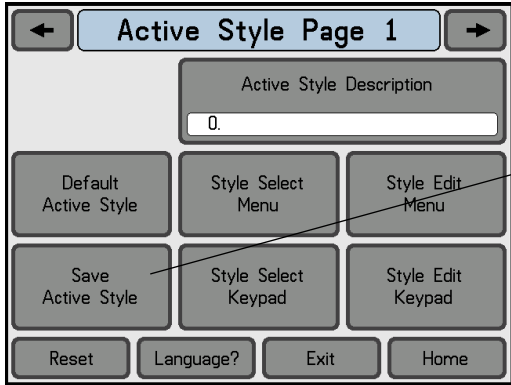

Note: Use this Same Procedure to change a single setting or all settings on pages 2 and 3

Press Exit to return to Page 1

Press Exit Setup or Home for Ready Screen

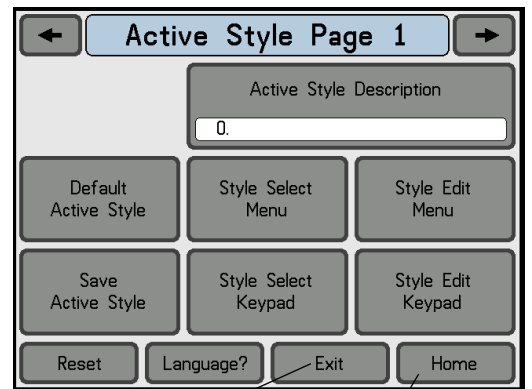
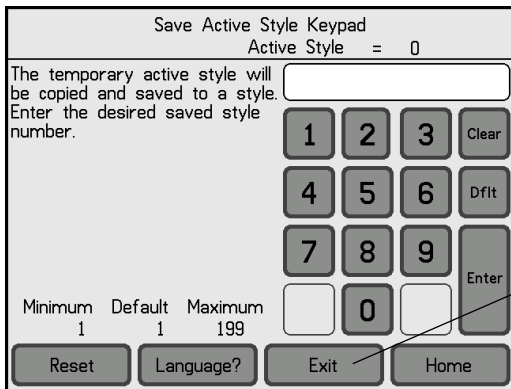

Press Exit or Home for Ready Screen

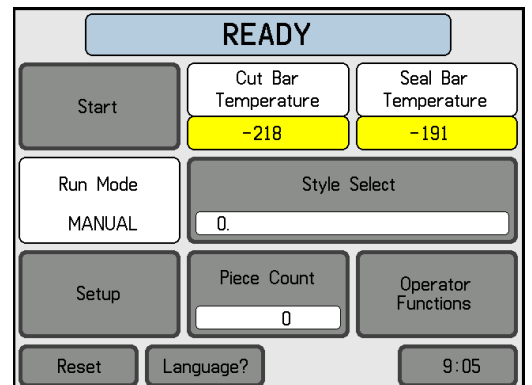
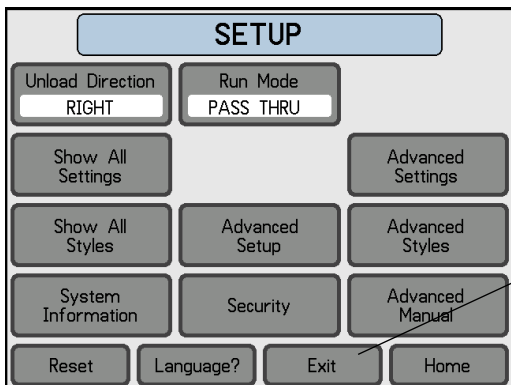

Shortest Method

With abbreviations only for each setting for quick changes to standard styles

Press Setup Button on Ready/Home screen

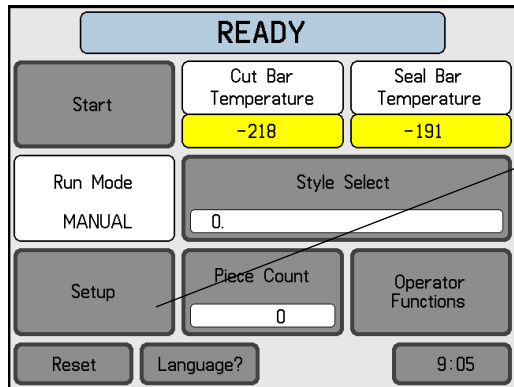

Press Show All Styles Button

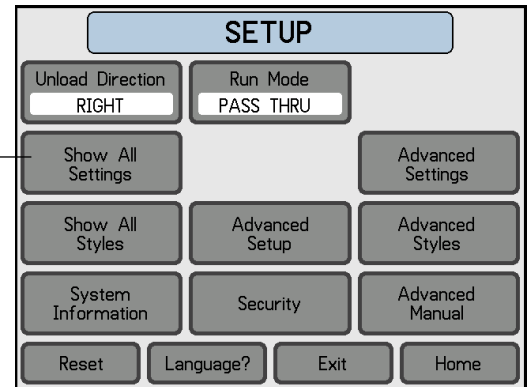

Press Edit Styles

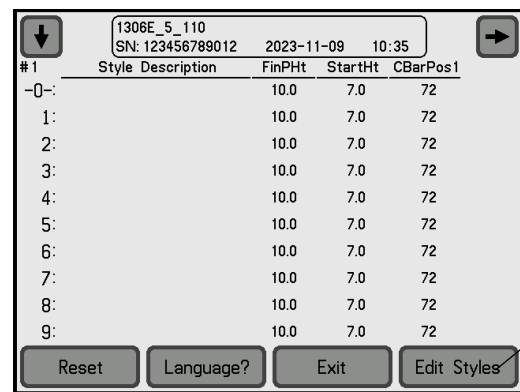

Locate and press value to be changed

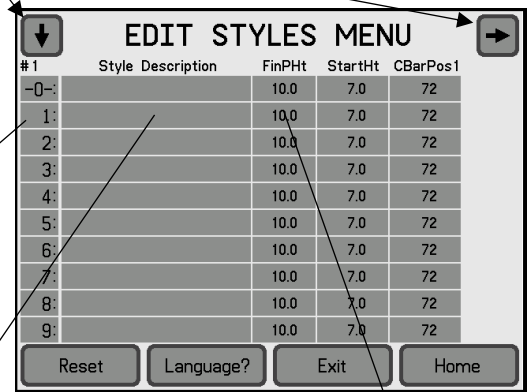

Press + / - to change number >>> then press enter to Save and Exit to go back to Menu

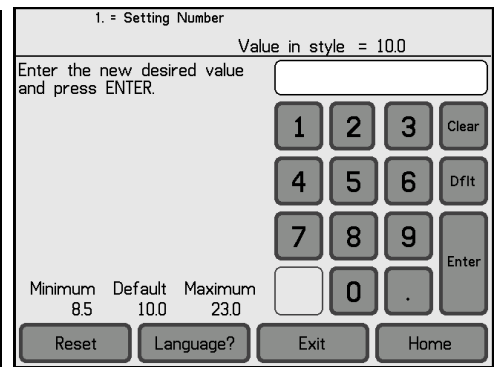
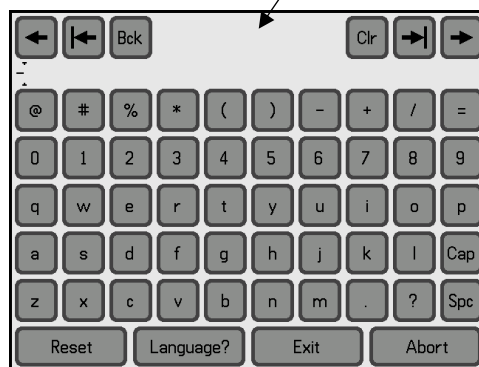
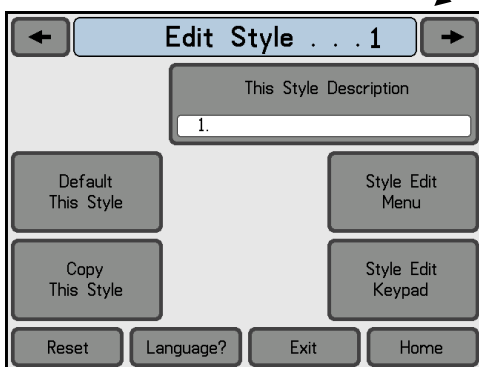

Press left or right arrow button to access # 1 -18 settings for Position, Height, Seal and Cut

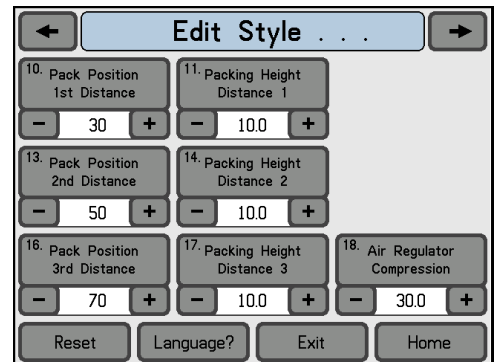
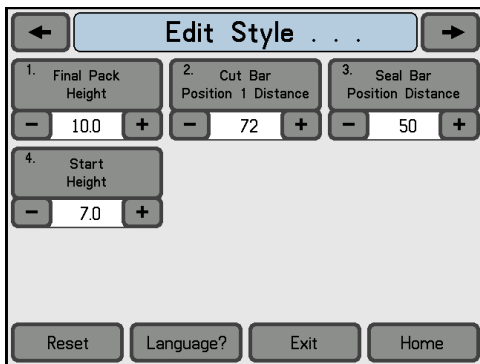
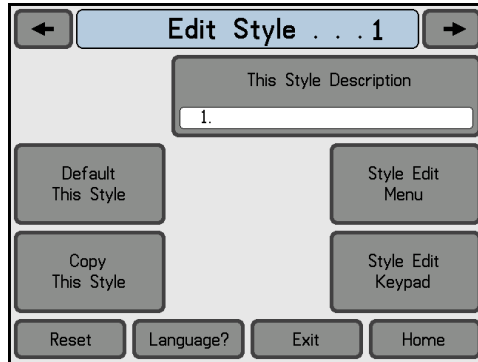

If you need to make additional changes locate the next setting and follow the same previous directions to change and save.

When finished with all changes. Press Exit for Previous Screen or Home for Ready

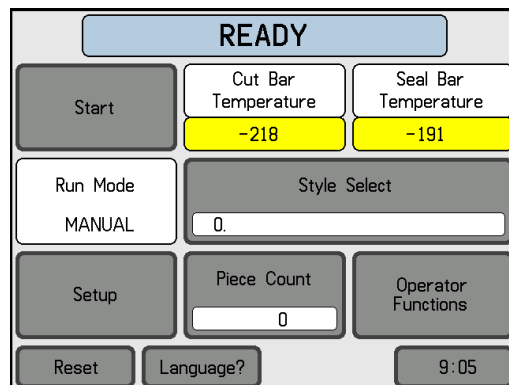

2.4. Maintenance

It is important that the machine operator read this manual and is familiar with all the functions and safety concerns of the unit before operating.



General Safety Instructions

The machine shall be switched off, come to a standstill, and be secured so that it cannot be switched on again inadvertently before starting any maintenance work whatsoever. Use proper lockout/tag out procedures to secure the machine against inadvertent startup. Remove any oil, grease, dirt, and waste from the machine, particularly from the connections and screws, when starting the maintenance and/or repair work. Do not use any corrosive-cleaning agents. Use lint-free rags. Retighten all screw connections that must be loosened for the maintenance and repair work. Any safety mechanisms that must be dismantled for setting-up, maintenance or repair purposes must be refitted and checked immediately after completing the work

Daily

- Investigate and report any unusual noises to the proper personnel.
- Check light tower operation
- Check touch screen function and clean with soft cloth. Never use anything sharp on surface.
- Monitor the air pressure filter/regulator and empty condensation and debris as necessary.
- Wipe all photocell lenses with a clean non-abrasive dry cloth.
- Clean the machine and surrounding area, keeping debris from becoming a trip hazard. This should be done once a day. Plastic scraps could jam machine mechanisms.
- Clean the seal and cut bars at least once a day, preferably at the beginning of shift before the machine has been turned on and the bars have heated up. To clean the bars, use a soft cloth and WD-40 as the solvent. Use extra care not to scratch the Teflon coating of the bars as this will cause the seal bars to stick to the plastic and render the bars ineffective at sealing/cutting

Weekly

- Use Daily list and implement these checks first.
- Clean Laser eyes on in-feed conveyor
- Lubricate all bearing on shafts on the main platform, pressing belt and unload unit. Oil all cylinder rods. Grease gear racks and chains on entire workstation
- Check alignment, tracking and tension of conveyor belts. Adjust as required.
- Check alignment, tracking and tension of encoder belts. Adjust as required.
- Check tightness of thermocouple and clean seal bar, with clean, soft rag and WD-40

Monthly

- Check for proper oil level in gear drive reduction cases and adjust as required.
- Check for proper oil level and leaks in hydraulic pump system. Use Shell Tellus® Oil 32 .
- Complete cleaning of entire workstation

2.5. Preventative Maintenance Charts

Shift - total of two(2) pages
Technical - total of four(4) pages

Preventative Maintenance (Shift Schedule)



1. POWER DOWN AND LOCK-OUT THE ELECTRICAL AND THE PNEUMATIC POWER SOURCES ON THE MACHINE.
2. WAIT UNTIL SEAL BARS COOL OFF SUFFICIENTLY (APPROX. 3 HOURS) BEFORE SERVICING THE SEAL BARS OR THE NEARBY AREAS OF THE MACHINE.

START

Safety is First Priority! Follow all Lockout/tagout procedures, before working on machine

1360F Roll Pack

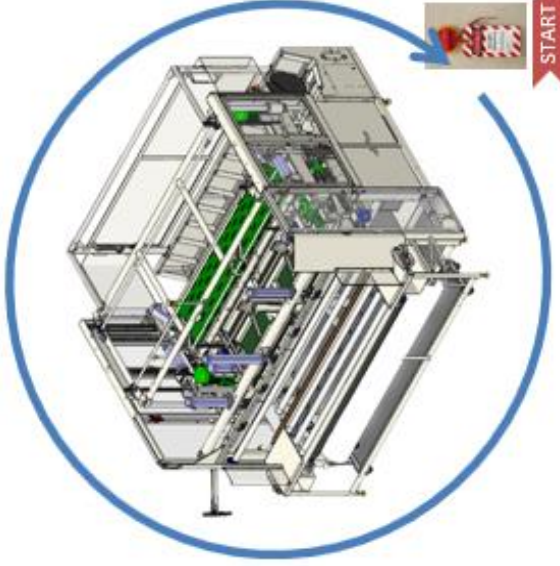

START

1. Check for unusual noises and or air leaks. Alert a technician.

Frequency

START MID END

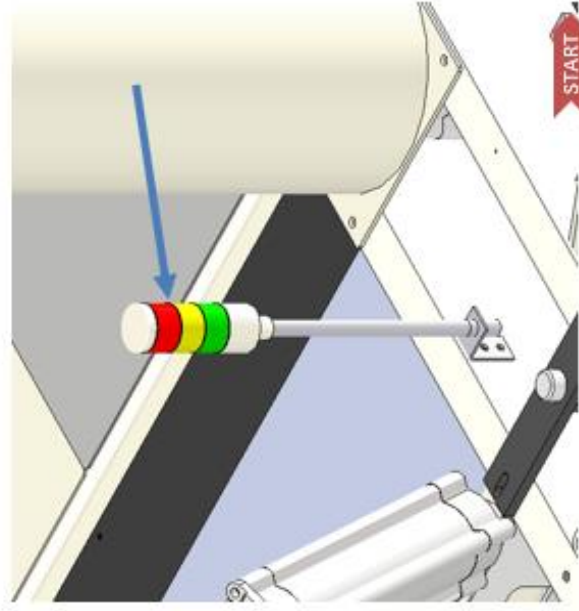

START

2. Check to see if the light tower indicator is working properly.



START

3. Check screen operation, clean with soft cloth, never use anything sharp to touch surface.



START

4. Check air pressure, must maintain a constant pressure during cycle and drain condensation.

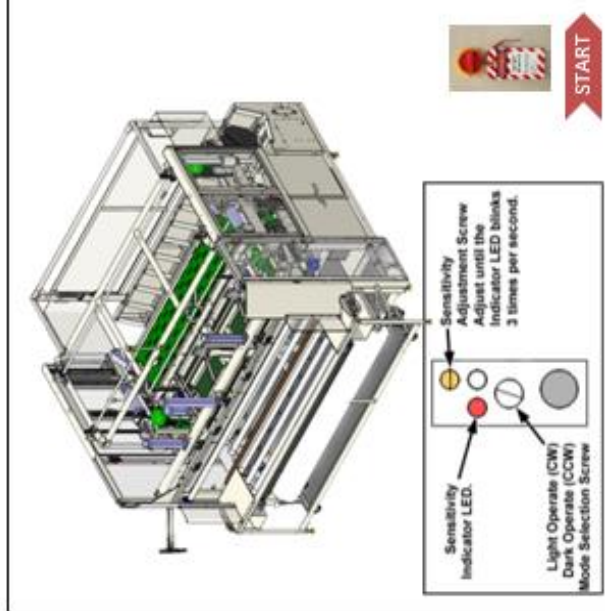

START

5. Check and clean photo eyes and reflective tape in all feed area. Replace tape if damaged.

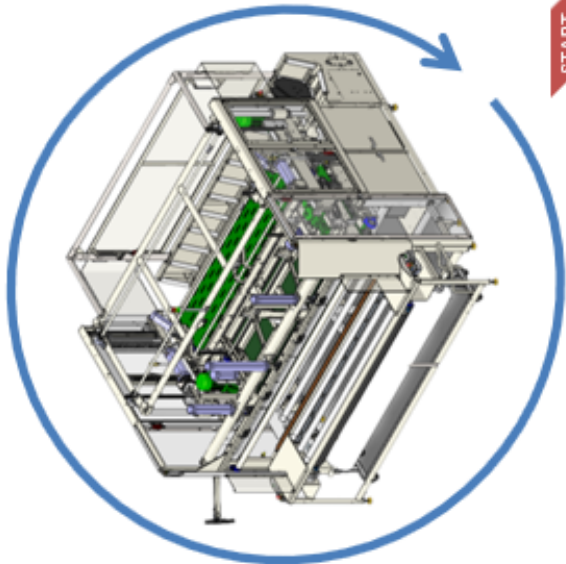

START

6. Complete a general cleaning of machine.

Additional Maintenance List or Notes:

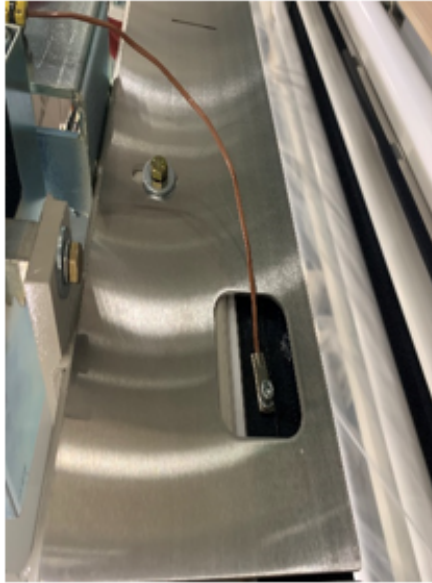

START

7. Clean and inspect seal bar for damage, cracks and wear. See next note on seal bars

**** Warning ****

Never for any reason

- Enter Inside the machine
- Crawl under the machine
- Climb on top of the machine
- Reach inside the machine
- Place any body parts inside the machine

After pressing the start button, the infeed belts will run continuously and will automatically process materials or products.

VERY Important Message:

Upper seal bars have a coating, and the Lower Seal bars are made of PTFE which is a non-stick material. Use extreme caution when inspecting seal bars . If everything looks perfect DO NOTHING. If this Teflon material is scratched or torn in some areas, it will cause buildup on the seal bar. If this happens, a clean thick rag with WD-40 sprayed on it, should be used to wipe the seal bar to keep it clean. By doing this it will prevent buildup and burn through.

caution

8. Use extreme caution, when cleaning. Never clean when "HOT" !

**** Warning ****
Never for any reason

Perform any machine maintenance unless the machine is properly powered down and cool.

Lockout/tagout procedures must be followed.

In manual mode, machine may be prompted to execute any of its functions. Only a properly trained operator or technician should work on or use the machine in manual mode of operation to prevent injury or machine damage.

Preventative Maintenance (Technical Schedule)



1. POWER DOWN AND LOCK-OUT THE ELECTRICAL AND THE PNEUMATIC POWER SOURCES ON THE MACHINE.
2. WAIT UNTIL SEAL BARS COOL OFF SUFFICIENTLY (APPROX. 3 HOURS) BEFORE SERVICING THE SEAL BARS OR THE NEARBY AREAS OF THE MACHINE.

DAY WEEK MONTH

Safety is First Priority! Follow all Lockout/tagout procedures, before working on machine

1306F Roll Pack Workstation

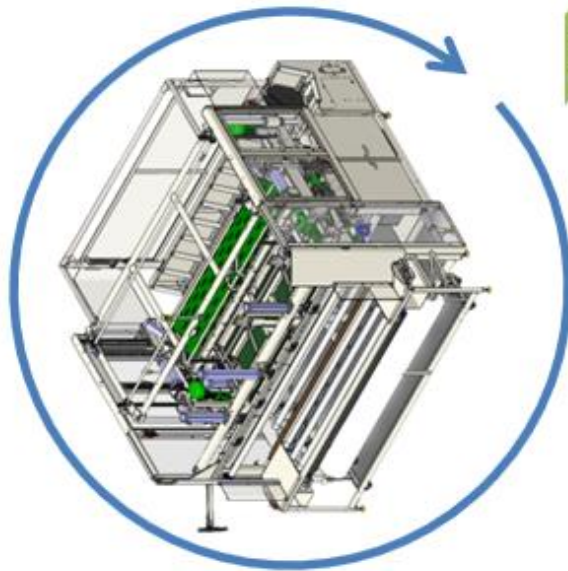

WEEK

1. Check for unusual noises and or air leaks.
2. Proceed with general cleaning of machine

Frequency

DAY WEEK MONTH

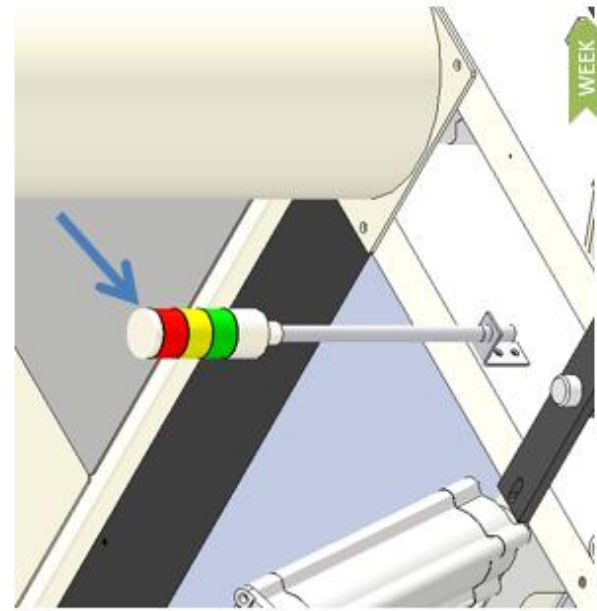

WEEK

3. Check to see that Light tower functions properly.



WEEK

4. Check screen operation, never use anything sharp to touch screen surface.



WEEK

5. Check air filter, drain condensation and replace as needed.

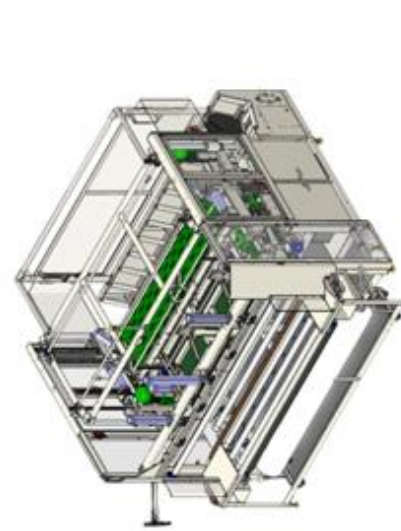

WEEK

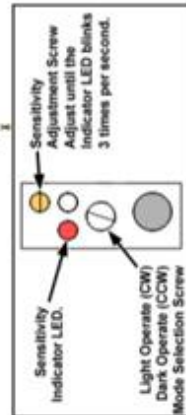

6. Check and clean photo eyes and reflective tape in all feed area. Replace tape if damaged.

Preventative Maintenance (Technical Schedule)

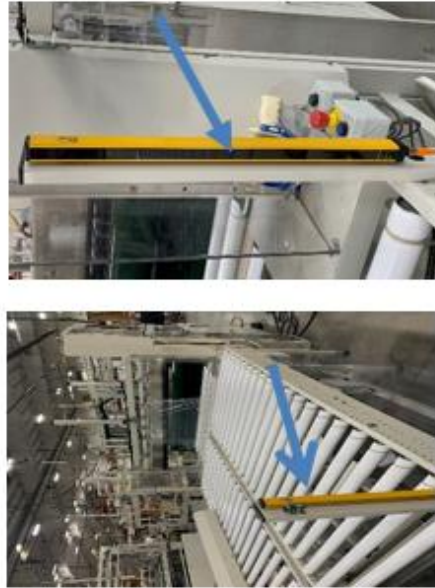

WEEK

6. a. If equipped, Check and clean Laser eyes on both sides of in-feed conveyor.

1306F Roll Pack Workstation

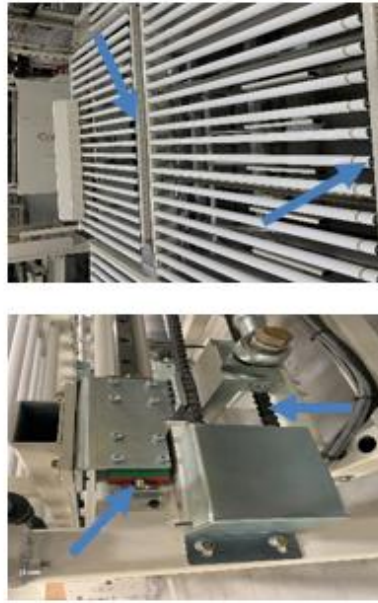

WEEK

6. b. If equipped, Check, align and clean conveyor belts and chain. Lubricate chain, bearings.

Frequency

DAY

WEEK

MONTH

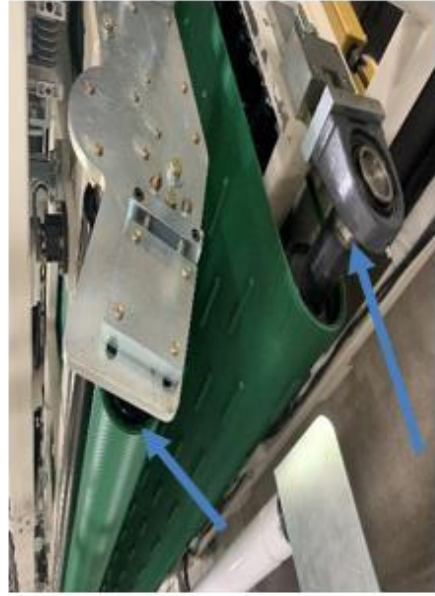

WEEK

7. a. Clean area around conveyor belts, check all set-screws and lubricate bearings.



WEEK

7. b. Lubricate roller bearing, check all set screws. Each end of top and bottom conveyors.



WEEK

7. c. Lubricate roller bearing, gears, gear rack and check all set-screws. Upper Conveyor.

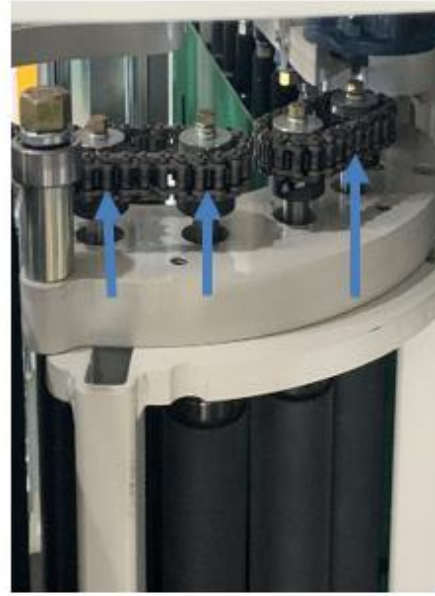

WEEK

7. d. Lubricate chains, gears and check all set-screws on each end of rolling chamber.

caution

Preventative Maintenance (Technical Schedule)

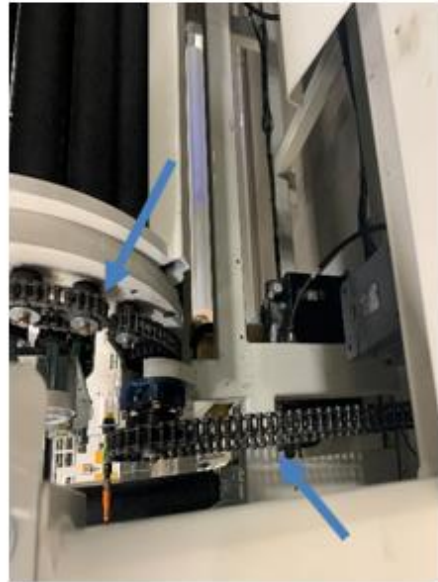

7. e. Lubricate chains, bearing and check set-screws on opposite side of rolling chamber.

1306F Roll Pack Workstation



7. f. Clean, lube chains & bar guides, do not touch with bare hands. Check all set-screws.

Frequency



8. Check the alignment and tension of the belts. Make sure they are tracking properly.



9. Check gear set-screws, belt alignment and tension on encoders. Run and check tracking.



10. Check sprocket set-screws, chain alignment and tension on all gear box drive motors.

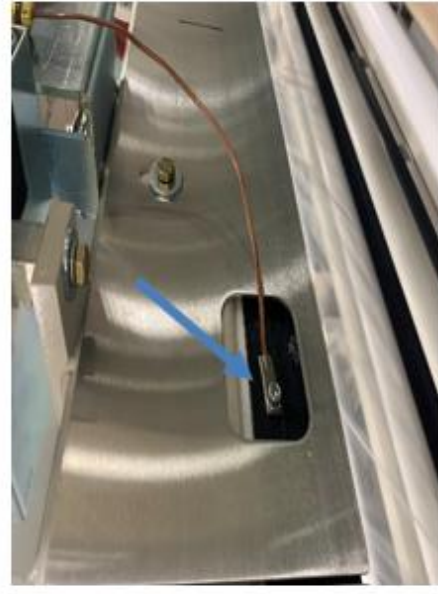

11. Check tightness of thermocouple and clean seal bar, when cool with clean rag and WD-40



VERY Important Message:

Upper seal bars have a coating of PTFE which is a non-stick material. Use extreme caution when inspecting seal bars. If everything looks perfect DO NOTHING. If this Teflon material is scratched or torn in some areas, it will cause buildup on the seal bar. If this happens, a clean thick rag with WD-40 sprayed on it, should be used to wipe the seal bar to keep it clean. By doing this it will prevent buildup and burn through.

caution

11. a. Use extreme caution, when cleaning.
Never clean when "HOT" !

Additional Maintenance List or Notes:

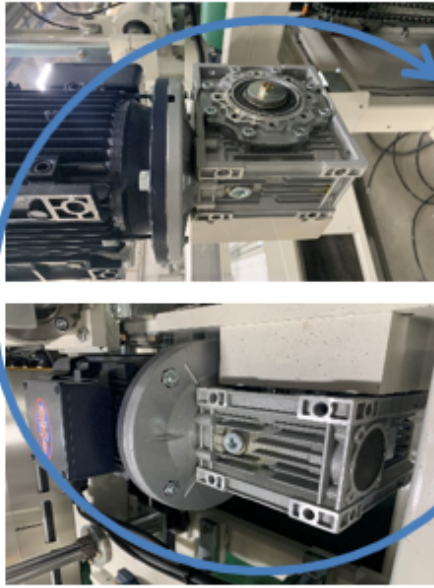

12. Check gear cases for proper oil level on upper and lower conveyor assemblies

**** Warning ****
Never for any reason

Enter Inside the machine
Crawl under the machine
Climb on top of the machine
Reach inside the machine
Place any body parts inside the machine

After pressing the start button, the infeed belts will run continuously and will automatically process materials or products



MONTH

13. Check for leaks, proper pressure and hydraulic oil level in reservoir. Fill as required.

**** Warning ****
Never for any reason

Perform any machine maintenance unless the machine is properly powered down and cool.
Lockout/tagout procedures must be followed.
In manual mode, machine may be prompted to execute any of its functions. Only a properly trained operator or technician should work on or use the machine in manual mode of operation to prevent injury or machine damage.

3. SERVICE

All maintenance should be performed by a qualified service technician.

3.1. Mechanical

VFD Motor Drives and Settings

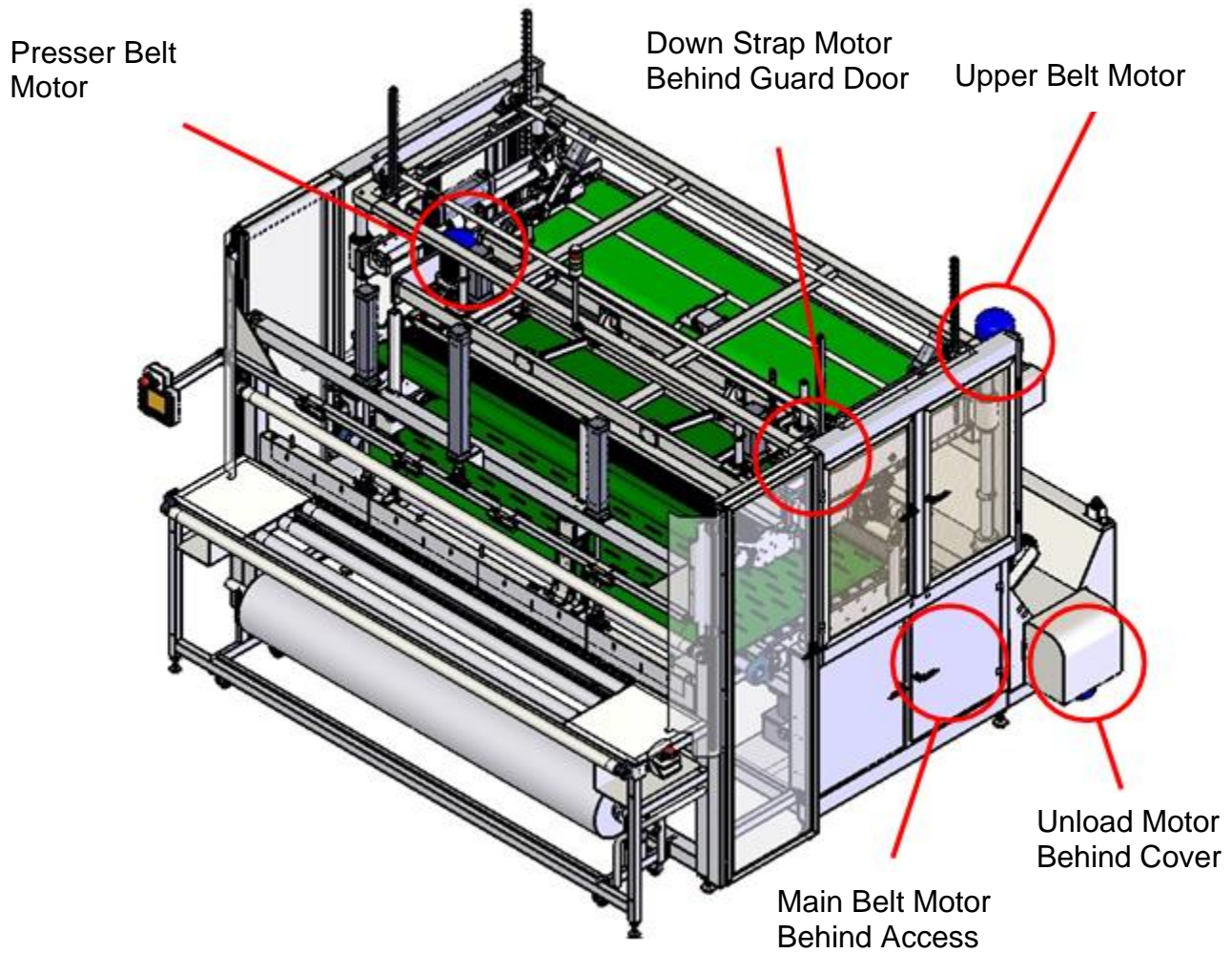

VFD Motor Drive Parameters

NOTE: All drives are pre-set at factory. Some changes are available within the program and are accessible through the touch screen. Reference VFD part number MM510155B1M1

NOTE: USE EXTREME CAUTION OR DO NOT CHANGE, THESE SHOULD BE FACTORY SET AT THEIR DEFAULT VALUES AND REQUIRE LITTLE TO NO ADJUSTMENT.

Pneumatic System

Main Air pressure regulator AA198-5110

The regulator assembly is located behind the table. The regulator is for the main air pressure, this is normally set to 80 to 90 psi.

The purpose of the regulator is to keep the operating pressure of the system (secondary pressure) virtually constant regardless of fluctuations in the line pressure (primary pressure) and the air consumption.

Clean air in your compressed air system is essential for the safe and efficient operation of this reliable power source. Harmful contaminants like oil, dust, dirt, rust, and water-alone or in combination-can attack your system and clog sensitive pneumatic instruments. It can also reduce the efficiency of air-operated tools. Wear out seals and erode system components. Increase maintenance and repair costs. Contribute to product rejects, production downtime-even complete plant shutdown.

Electronic Pressure Regulator AA198-3050A

The regulator assembly is located above main regulator. These regulators are used to control pressure exerted before and during the rolling process.

Air pressure module. 4080-200

It is the Sensor responsible for the detection of the secondary air pressure if it does not reach the pre-adjusted value.

For more details of connections see plumbing diagram part # 1306D-PD located in manual or within the main control panel door pocket



3.2. Electrical



All maintenance should be performed by a qualified service technician.

Main Power Switch



The main power on/off switch is on the side of the machine. It is used to turn the power on to the whole machine. This machine requires 220V-240V Three Phase 50 Amps. If you have problems the power not coming on when the on button is pressed, you may check this switch by doing the following.



with



ATTENTION. Make sure that the machine is unplugged before proceeding and that all lock out/tag out procedures have been correctly followed (See to Lockout tag out procedure)

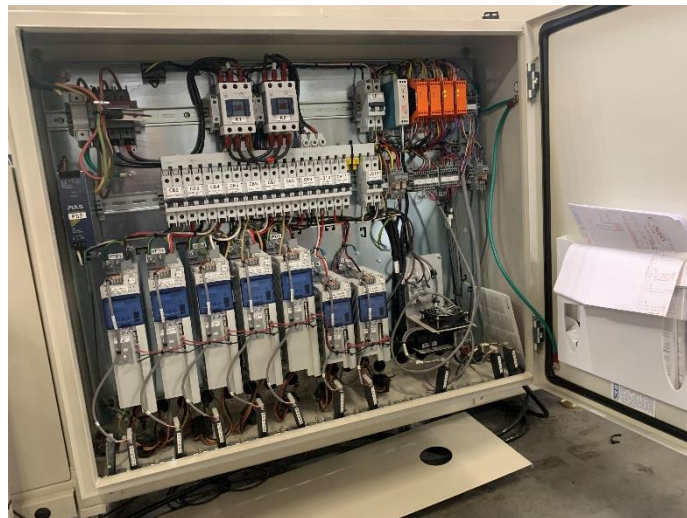

- Check the circuit breakers if any of the breakers had gotten overloaded at some point.
- Replace the cover, plug the machine in, and try turning the machine back on.
- If the contact still trips the overload, then there is a problem either with the wiring or the contactor.
- Use the wiring diagram for your machine in the parts manual to check the voltages.
- Try replacing the circuit breaker.

3.3. Standard Modules

Program Module...4080-150

It stores the program information. It is also used to load program modifications or updates. For update procedures please refer to next chapter.



Memory Module...4080-970

Stores the unique data required to operate this particular machine, such as serial number, original factory parameters, etc. This module should never be exchanged with another machine.



Output Module...4080-140

They are responsible for transferring signals from the computer to the working elements such as valves, motors and relays, etc.



Optical Output Module...4080-130

They are responsible for transferring signals from the computer to the electronic regulators to control air pressure.



Input Module...4080-110

They are responsible for transferring signals from the machine to the computer such as switches, electric eyes, sensors, etc.



Thermal Couple Module...4080-250

They are responsible for transferring heat measurements from the machine to the computer to control temperature on the cut and seal bars.



NOTE:



1. Even though all output and/or input modules within the machine are identical, they cannot be moved to replace another module same on the serial bus cable, as the computer automatically assigns a working address for each one.
2. If a replacement is necessary, always replace with a new or loaner module from another machine.
3. Electrical Power to the machine must be turned "OFF" during replacements.
4. Computer will show an error if one or more modules are missing.

Procedure: Remove the old module and connect the new one, after turning on the power, the computer will reassign the address to this new module.

Troubleshooting

Help Screen... On board Explanations Help or detailed explanations are accessed by holding a button (actual name of function) and upon release will display information, which describes the function.

Error Messages

Cut Bar

Temperature Error- Low

Seal Bar

Temperature Error- Low

Air Pressure

Air pressure - Low

Missing Module Error

Module – No response detected

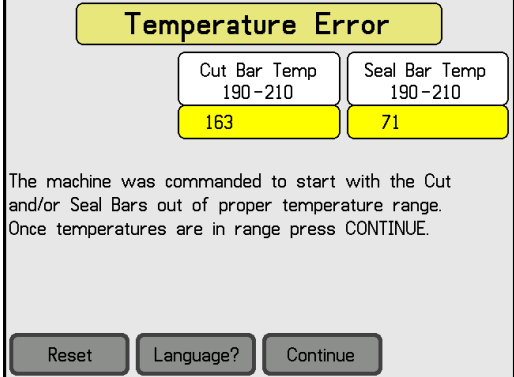

Temperature Error

Cut Bar Temp 190-210	Seal Bar Temp 190-210
163	71

The machine was commanded to start with the Cut and/or Seal Bars out of proper temperature range. Once temperatures are in range press CONTINUE.

Reset Language? Continue

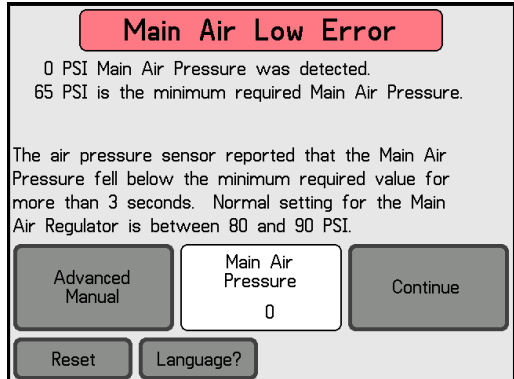

Main Air Low Error

0 PSI Main Air Pressure was detected.
65 PSI is the minimum required Main Air Pressure.

The air pressure sensor reported that the Main Air Pressure fell below the minimum required value for more than 3 seconds. Normal setting for the Main Air Regulator is between 80 and 90 PSI.

Advanced Manual Main Air Pressure 0 Continue

Reset Language?



MISSING MODULE ERROR

No response from module: 57
Expected module part number: 4080-200
of minimum batch code: :000

The original module is missing or has been replaced. Press CONTINUE once this module is installed again or replaced with a new module having the part number shown above. Press HELP to display module descriptions.

Reset Help? Continue

Others

Below are several random examples of on-board self-diagnostics screens for reference only.

Most error or troubleshooting screens will not be visible or may never become visible unless an issue becomes present. Help or details are listed on each screen.

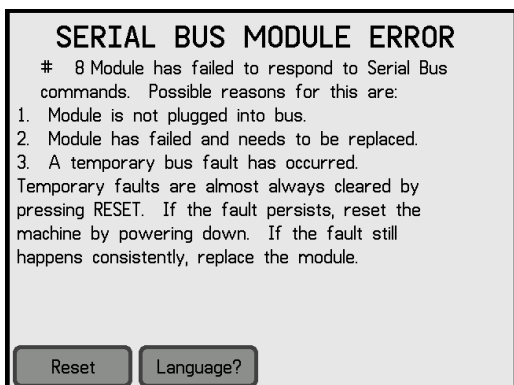
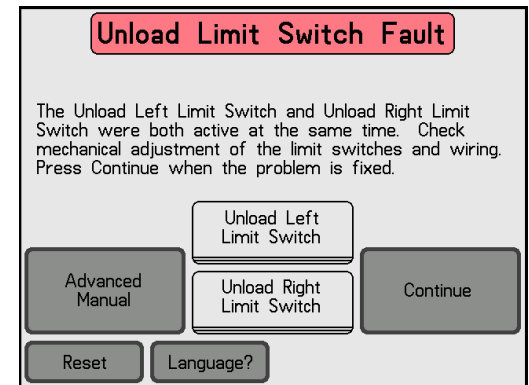
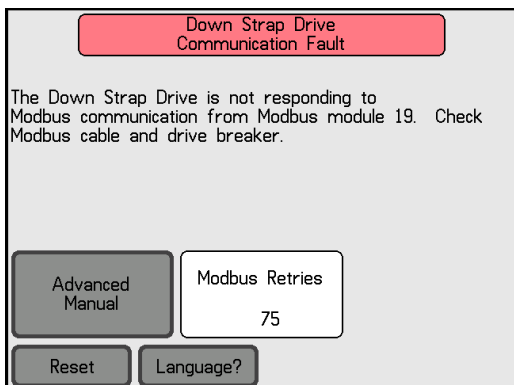
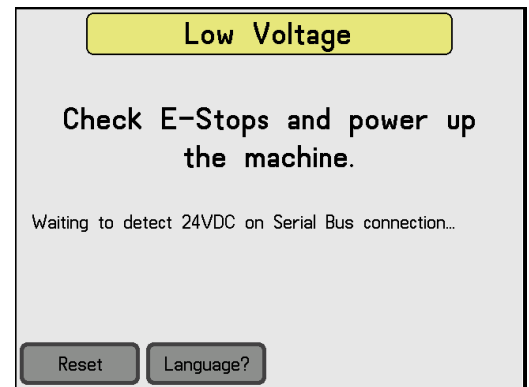
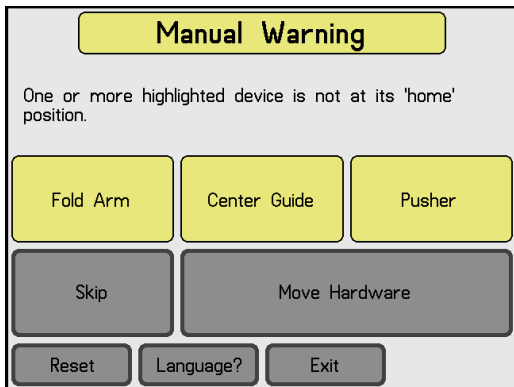

4. Assembly Drawings & Parts Lists

The materials contained herein are confidential and proprietary information of Atlanta Attachment Company. In addition to any confidentiality and non-disclosure obligations that currently exist between you and Atlanta Attachment Company, your use of these materials serves as an acknowledgment of the confidential and proprietary nature of these materials and your duty not to make any unauthorized use or disclosure of these materials.



One-Stop Shopping
For Expendable Replacement Parts for AAC & Other Bedding Equipment Suppliers
Toll Free: **1-866-885-5100**
www.atlantapartsdepot.com • sales@atlantapartsdepot.com

11306F Automatic Roll Pack Workstation

AAC Drawing Number 9009028 Rev 2

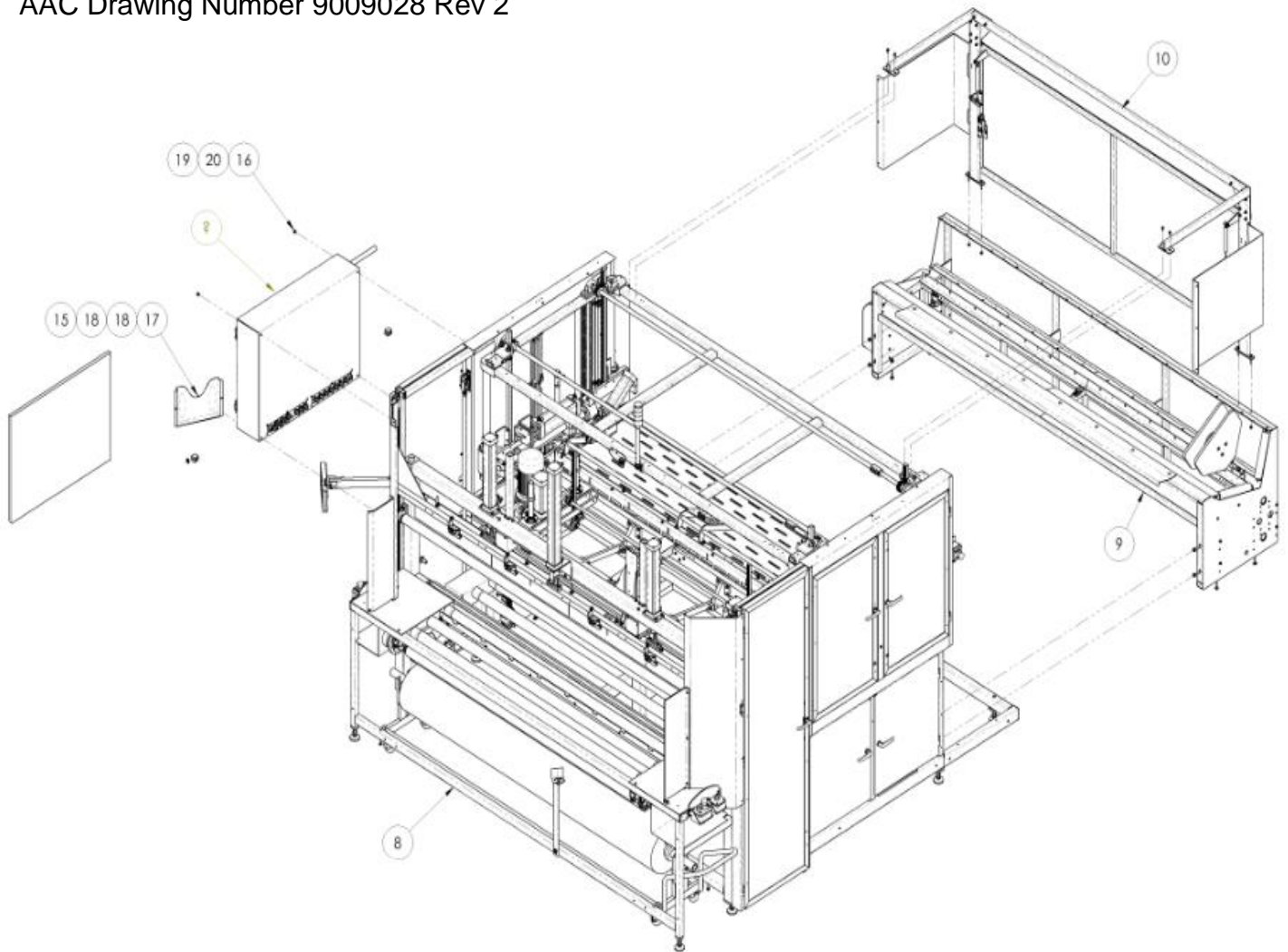

ITEM #	QTY.	PART #	DESCRIPTION
1	*1	1010	CABLE, 2C, 18GA, YEL SPIRAL
2	*1	1011	CABLE, 2C, 18GA, BLUE SPIRAL
3	*1	1012	CABLE,2 COND,18 AWG,CUSTOM,.050" RED
4	*1	1013	CABLE,2 COND,18 AWG,CUSTOM,.050" GRN
5	*1	1306-LAB1	LABEL,NAME PLATE,ENGRAVED
6	*1	1306-PD3	DIAGRAM,PNEUMATIC,1306
7	1	13061195	CABINET, ELECTRICAL CONTROLS, 1306E
8	1	13061300	ROLL PACK SUB ASSY, GENERIC
9	1	13061310	OFFLOAD PUSHER, ROLLER
10	1	13061330	GUARDING AND SHIELDS, OUTFEED
11	1	1306F-WD1	DIAGRAM,WIRING,CONTROL BOX
12	1	1306F-WD2	DIAGRAM,WIRING,SBUS
13	*1	1306F-WD3	DIAGRAM, WIRING
14	*1	1306F-WD4	DIAGRAM WIRING
15	2	NNK3/8-16	NUT, KEP, 3/8-16
16	2	SSHC10032	5/16-18 X 1/2 HHCS
17	2	SSHC25048	3/8-16X3/4,HEX CAP
18	4	WWFS3/8	WASHER,FLAT,SAE,3/8
19	2	WWFS5/16	WASHER,FLAT,SAE,5/16
20	2	WWL5/16	WASHER,LOCK, 5/16

13061195 Cabinet, Electrical Controls

AAC Drawing Number 13061195 Rev

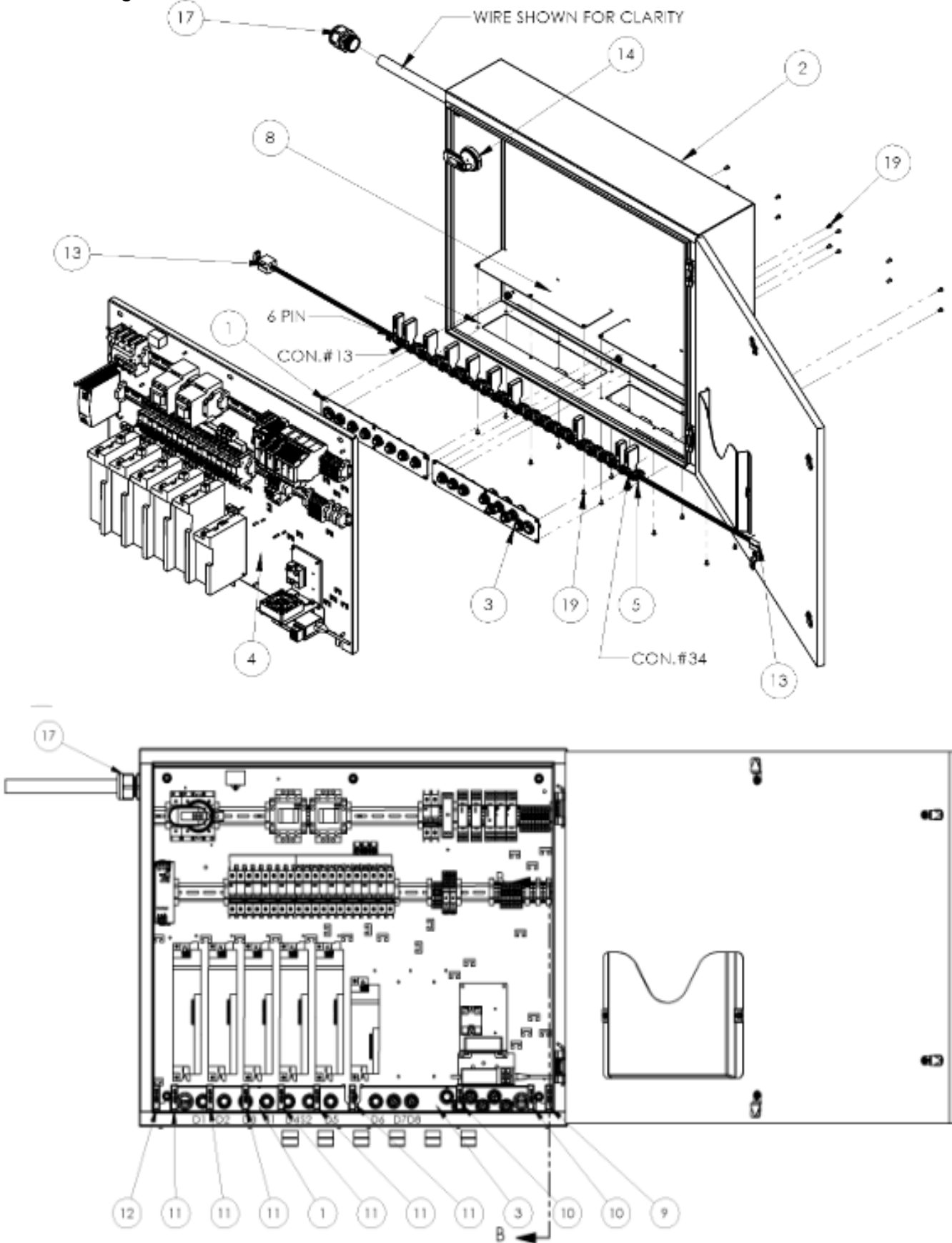

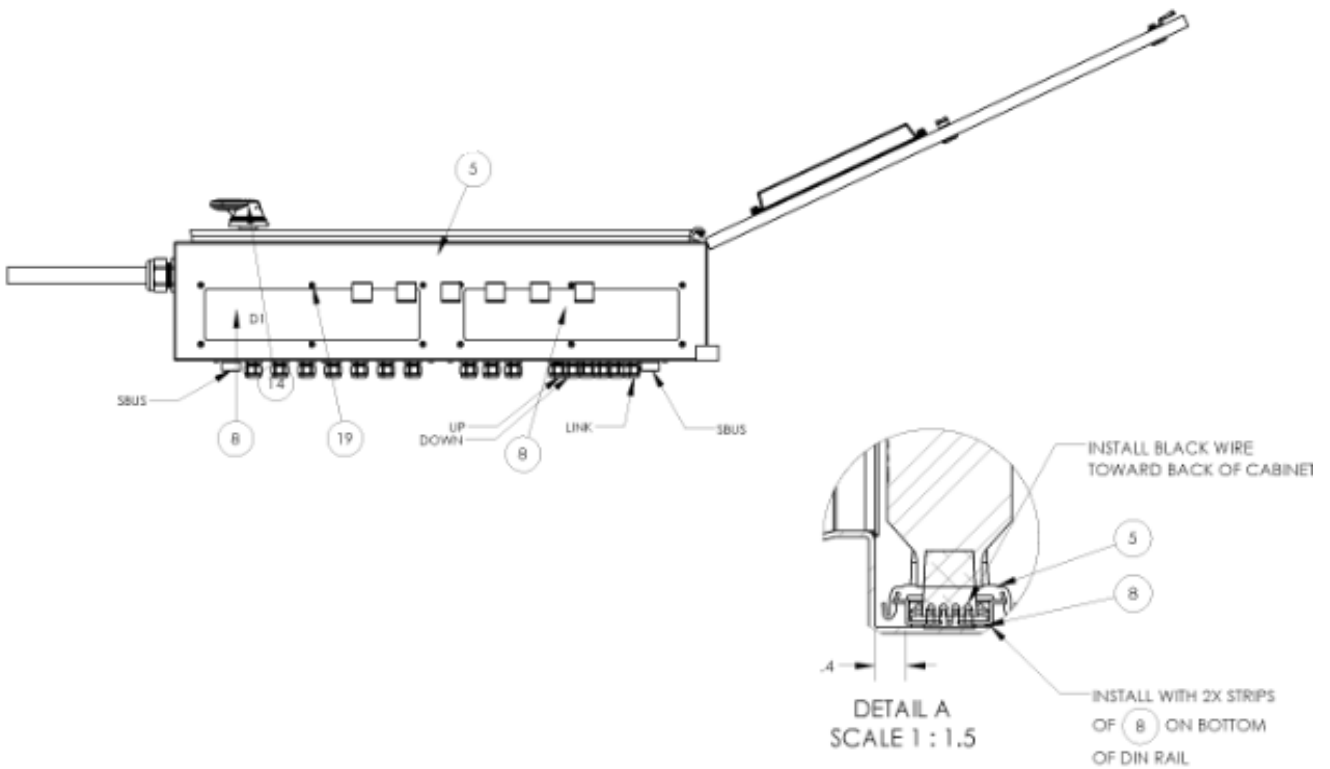

ITEM NO.	QTY	PART NUMBER	DESCRIPTION
1	1	13061068	PLATE, GLAND, CABINET, REAR BTM
2	1	13061116	CABINET, 1306D GENERIC,
3	1	13061193	PLATE, GLAND, CABINET, REAR BTM
4	1	13061196	PANEL ELECTRICAL CONTROL 1306E
5	1	13061197	SBUS ASSEMBLY, 1306D, DF, E
6	1	1306EN-WD1	DIAGRAM, WIRING, CONT. BOX, POWER
7	1	1306E-WD2	DIAGRAM, WIRING, SBUS
8	2	13901036	PANEL BLANK CABLE ENTRY, BTM
9	1	4080-110	MODULE, QUAD INPUT
10	2	4080-140	MODULE, QUAD OUTPUT
11	6	4080-270	MODULE, MODBUS
12	1	4080-950	MODULE, POWER
13	8	EE64151B	FERRITE CORE, SPLIT, CABLE
14	1	EEHR65	DISCONNECT HANDLE, PISTOL
15	*1	FFRTV1035	SILICONE, RTV, CLEAR, NON-COROS
8	1	MM4952-1/4	TAPE, DOUBLE SIDED, 1/4"W X .035 T
17	1	RBM4524	STRAIN RELIEF, 1-1/4 NPT, .87-.1.26, BLK
18	1	RBM9144	LOCKNUT, NYLON, 1-1/4"NPT
19	24	SSPP98024	10-32 X 3/8 PAN HD PHILIP

13061196 Electrical Control Panel
 AAC Drawing Number 13061196 Rev

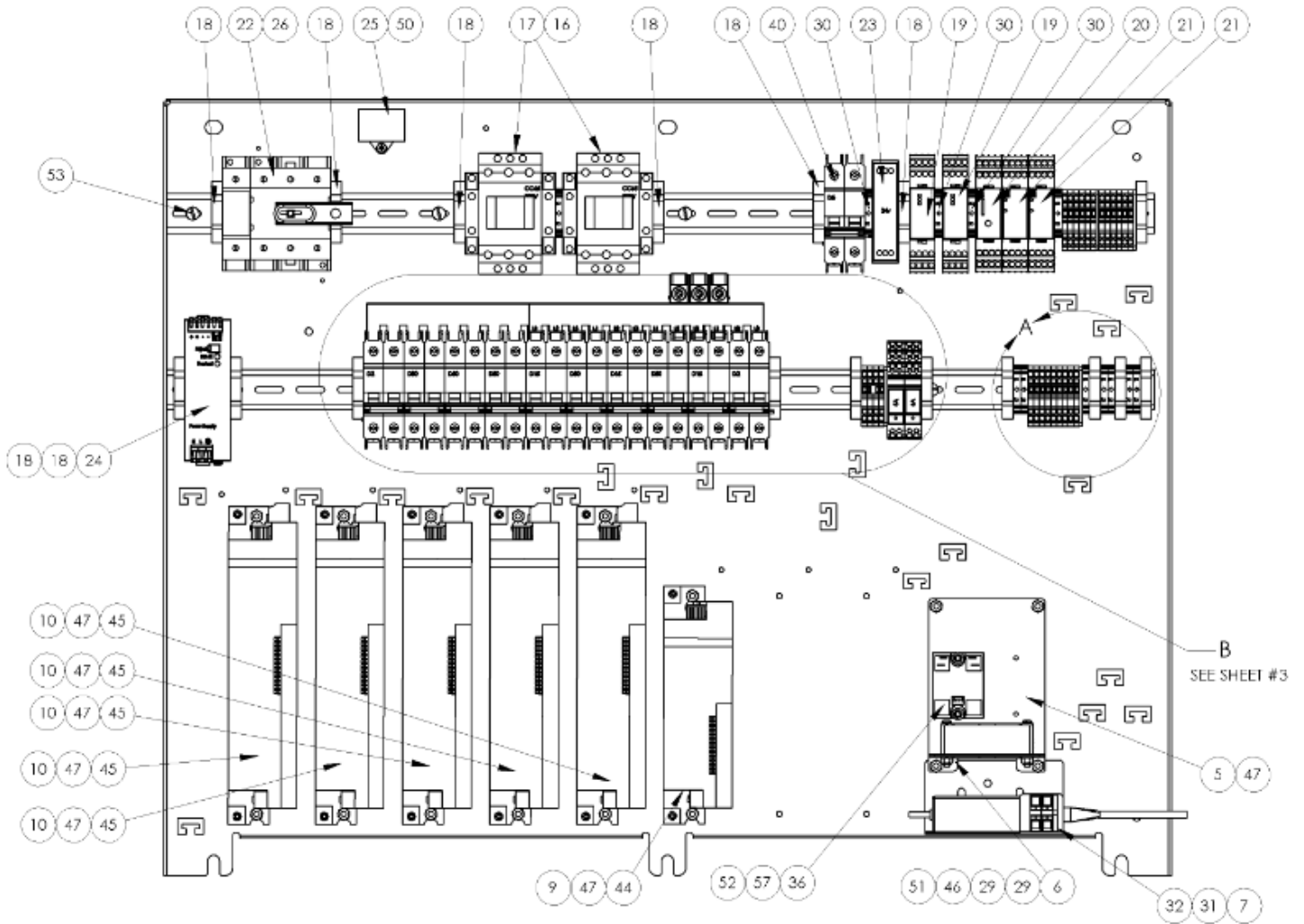

ORDER AND QUANTITY OF COMPONENTS IS IMPORTANT

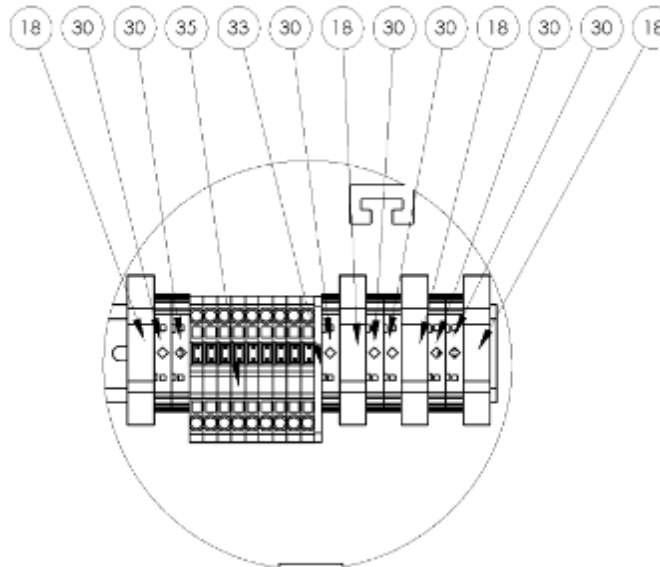

DETAIL A
 SCALE 1:2

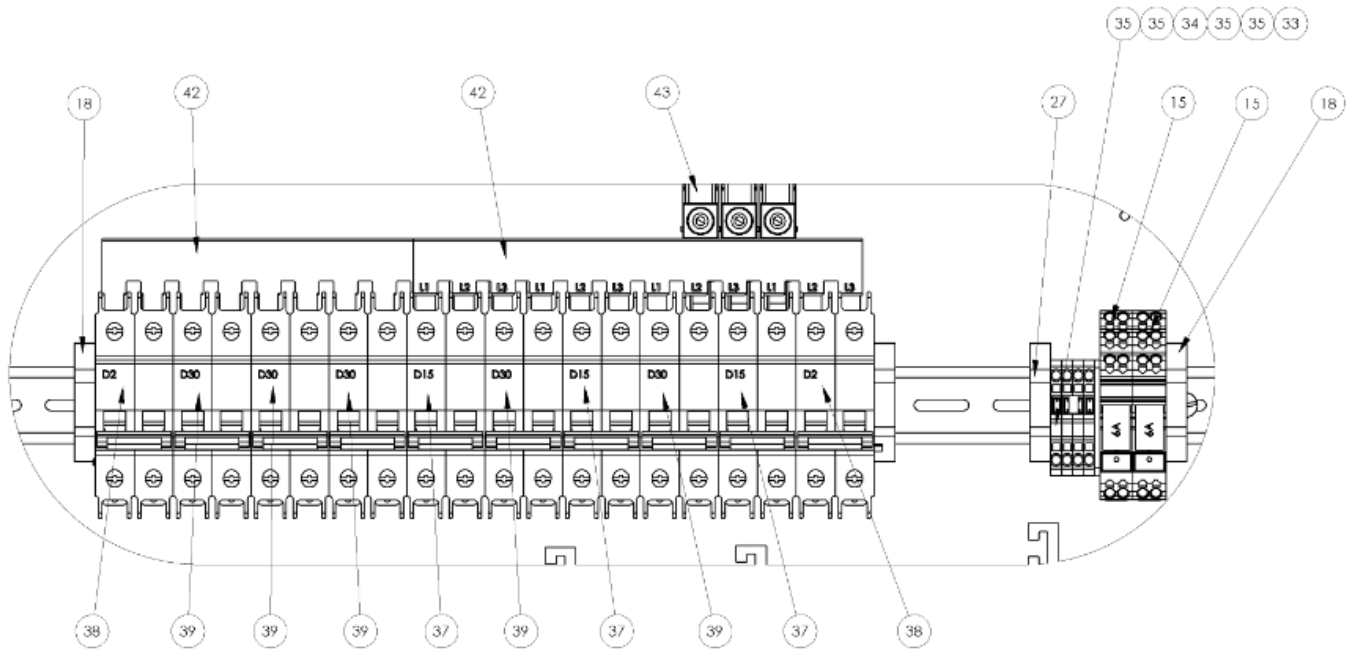
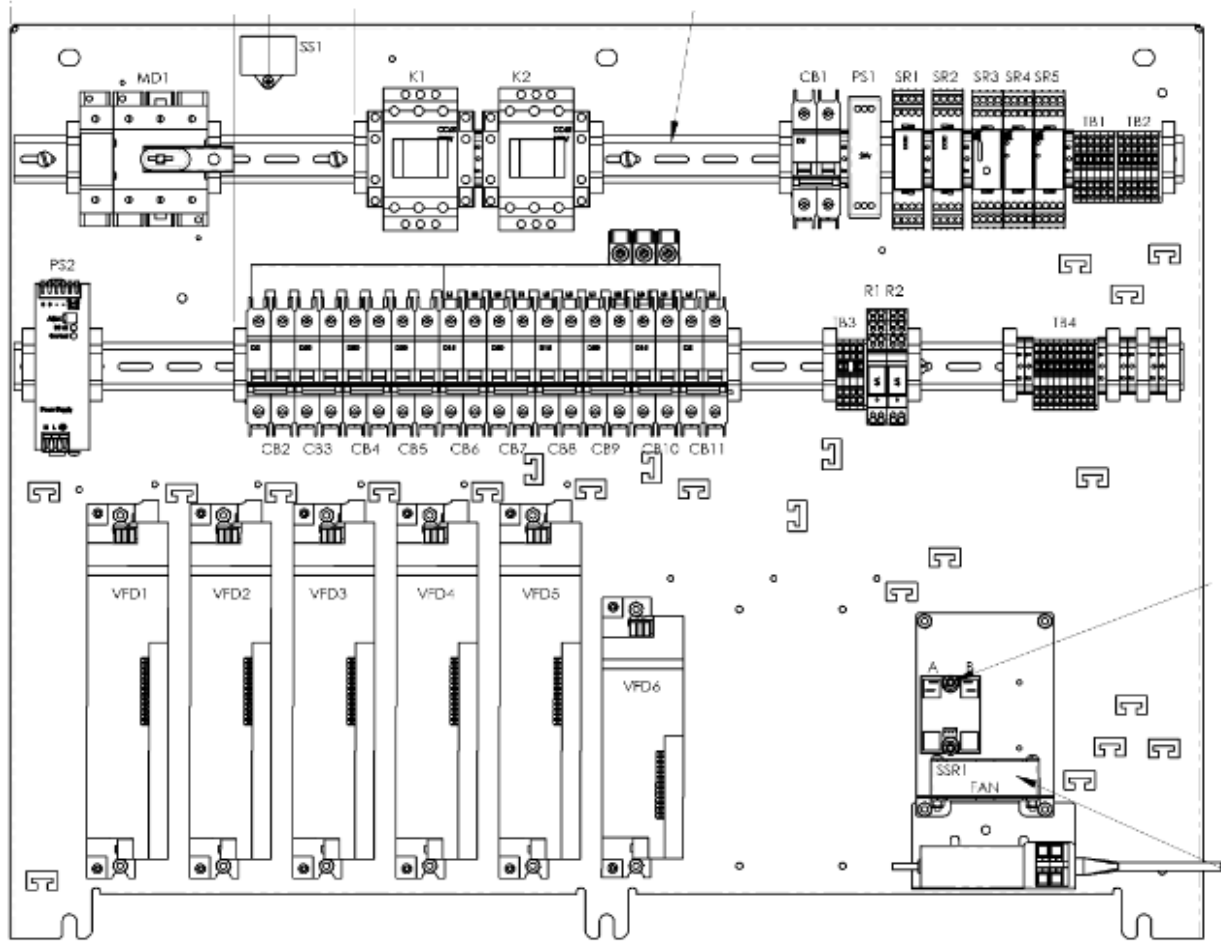

DETAIL B
 SCALE 1 : 2

13061196 parts list

ITEM	QTY.	PART NUMBER	DESCRIPTION	ITEM	QTY.	PART NUMBER	DESCRIPTION
1	1	13061066	PANEL, SUB, 1306 BASIC	30	12	FF209-120	DIN MOUNTING FOOT,SHORT
2	*1	1306F-WD1	DIAGRAM,WIRING,CONTROL BOX	31	2	FF264-341	TERMBLK,W AGO, TOP, DUAL, GRY
3	*1	1306F-WD2	DIAGRAM,WIRING,SBUS	32	1	FF264-371	TERMBLK,W AGO, TOP, END
4	*1	1306F-WD3	DIAGRAM,WIRING,	33	4	FF280-308	TERMBLK ENDPLATE,W AGO,280
5	1	13901012	PLATE, HEAT SPREADER, SINK	34	1	FF280-402	JUMPER,W AGO, TOP, SNGL
6	1	13901078	MOUNT, FAN	35	25	FF280-901	TERMBLK,W AGO, TOP, SNGL, GRY
7	1	13901384	PC POWER BLOCK BRACKET	36	1	FF84140210M1	RELAY,SSR,24VAC,25A
8	1	4080-4250-29	CABLE,SBUS,POWER,DIN PS TO PWR MOD,29"	37	3	FFFAZD152NA	BREAKER,2P,1.5A,UL489,240VT-MAG
9	1	4080-4251-12	CABLE,SBUS,MODBUS I510 DRIVE,12"	38	2	FFFAZD22NA	BREAKER,2P,2A,UL489,240VT-MAG
10	5	4080-4251-15	CABLE,SBUS,MODBUS I510 DRIVE,15"	39	5	FFFAZD302NA	BREAKER,2P,30,UL489,240VT-MAG
11	*1	4080-4255	CABLE, SBUS, PAUSE/WARN, 2 COND, 3'	40	1	FFFAZD52NA	BREAKER,2P,5A,UL489,
12	1	4080-4260	CABLE, SEAL BAR SSR, SBUS, 4 COND, 13"	41	1	FFHSP1	THERMAL PAD
13	1	4080-4261	CABLE,SBUS,3 CHAN HYDRAULIC CONTROL	42	2	FFM9XUP312	BREAKER,ACC,UL489,COMB,18MM,3P12
14	1	4080-4262	CABLE,SBUS,SOL VALVE	43	3	FFM9XUPC04	BREAKER,ACC,UL489,COMB,18MM, TOP
15	2	EE788384	RELAY, 24V, DPDT SAFETY WAGO DIN	44	1	MM510155B1M1	DRIVE, VFD ,I510,7.5HP, 240V, 1 PH, NEI,
16	2	EEAP9	COVER,SAFETY, CONTACTOR,65A,	45	5	MM510215B1M1	DRIVE, VFD, I510, 2HP, MODBUS
17	2	EECGC85A220	CONTACTOR,65A,220VAC	46	4	NINE8-32	NUT,ELASTIC LOCK, 8-32
18	17	EECLIPFIX	ANCHOR,DIN RAIL	47	16	NINK10-32	KEP NUT, 10-32
19	2	EELG5925-24	RELAY,SAFETY, 2 CHAN, 24V	48	1	PPFH832-6	STUD, PEM, 8-32 X 3/8, .040MST, STL
20	1	EELG5928-3	RELAY,SAFETY,24V,EXTENSION,DLAY	49	1	PPFJ032-12	STUD,PEM,10-32X3/4, .040MST, FHS,SST
21	2	EELG5929-61	RELAY,SAFETY,24V,EXTENSION,5 NO,1 NC	50	1	SSPP90032	SCREW,#8-32 X 1/2, PAN HD, PHIL
22	1	EEM60U3M	DISCONNECT, 3PH, 60A, UL98	51	4	SSPS90096	#8-32 X 1-1/2 PAN HD
23	1	EEMDR2024	POWER SUP,SWITCHER,24V,1.0A,DIN	52	2	SSSC90024	8-32 X 3/8 SOC CAP SC
24	1	EEQS5DNET	SUPPLY, PWR, SW, 2VC, 3.8A, DIN	53	12	SSTS98024	10-32 X 3/8,TRUSS HD
25	1	EERC601BUZ4M1	PROTECTOR, SURGE, W/RING TERMINALS	54	14	TT190670008	TERM,RING,1/4",8AWG,INSL
26	1	EESPA210-6.90	DISCONNECT SHAFT,MOD	55	3	TT191930152	TERM,RING,1/4",8AWG,NON INS
27	2	EETS35X7.5A	DIN RAIL-AMERICAN	56	27	TTDBNYDS218	TERM, FLAT BLADE,INS, 14 AW G,BLUE
28	2	FF08172	FAN GUARD, 80MM, METAL	57	2	WWSB8	WASHER,BELVEL,#8
29	1	FF109R0824SM1	FAN ASSY, 24V, 80MM	58	1	WWSI8	WASHER,INT. TOOTH, #8

13061300 Roll Pack Sub-Assembly, Generic

AAC Drawing Number 13061300 Rev 1

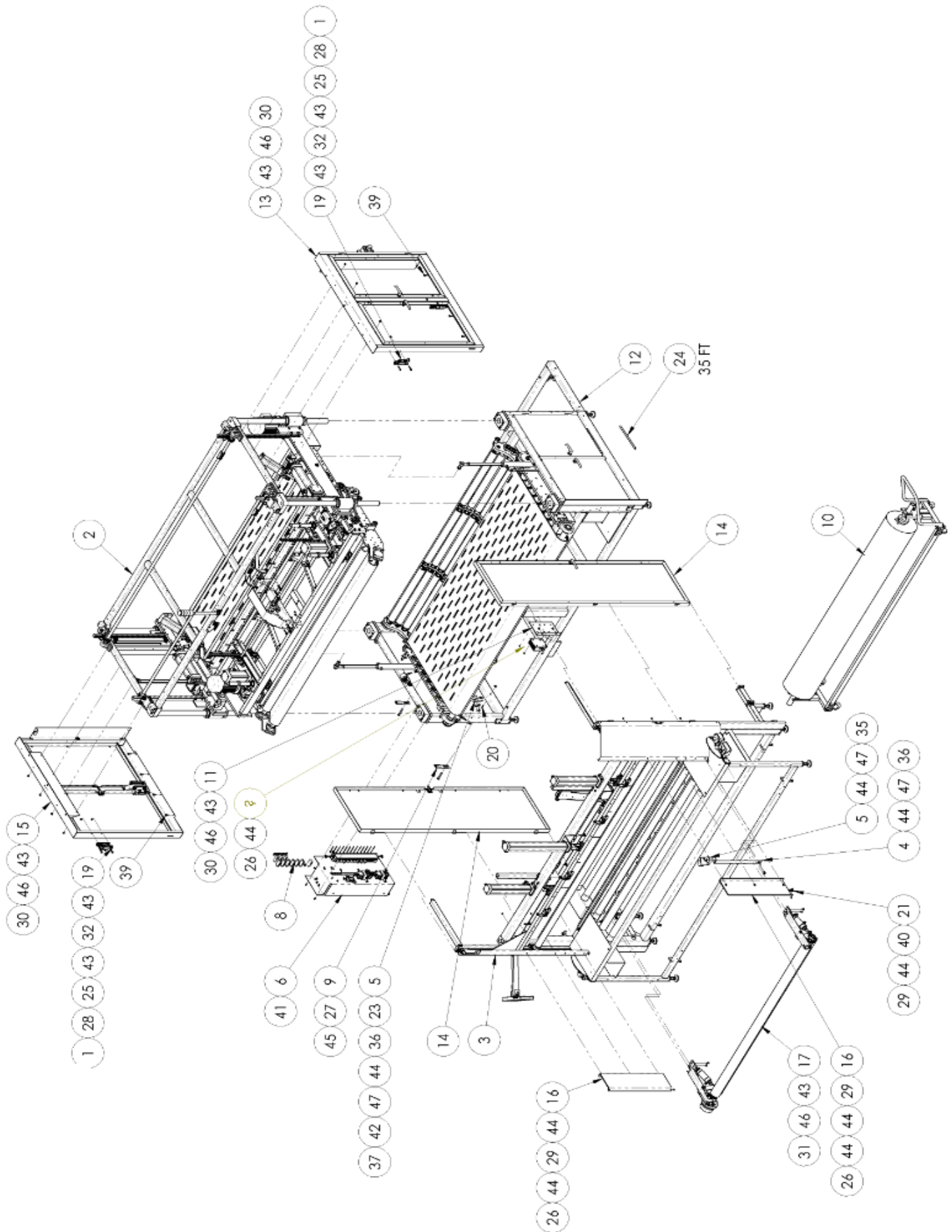

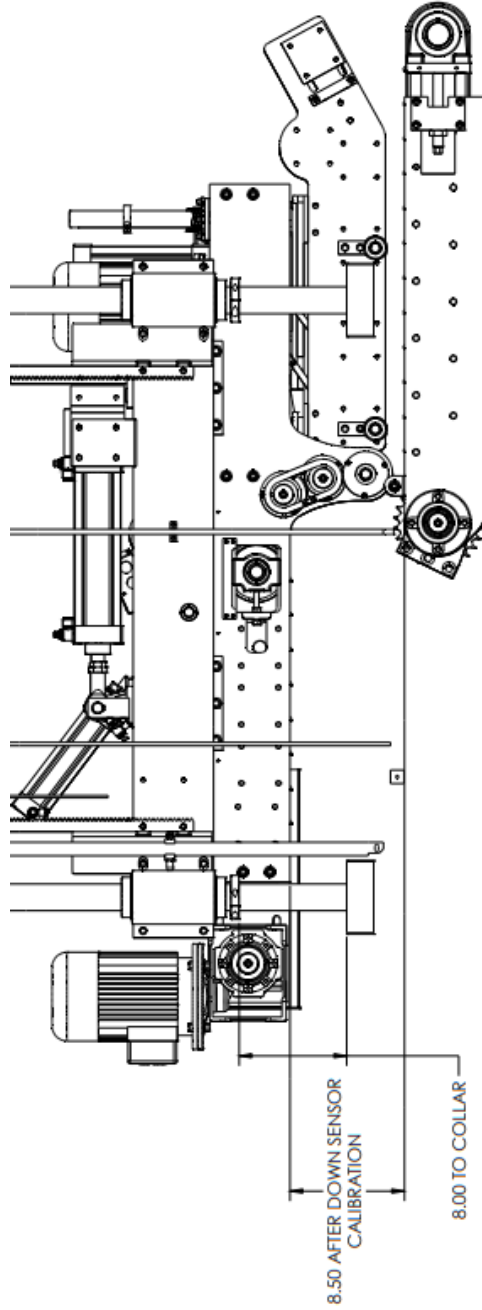

ITEM	QTY.	PART #	DESCRIPTION	ITEM	QTY.	PART #	DESCRIPTION
1	2	1060008	PLATE,NUT,8-32X.50	25	10	NNK1/4-20	NUT,KEP,1/4-20
2	1	1306079	TOP COMPRESSION ASSEMBLY	26	10	NNK10-32	KEP NUT, 10-32
3	1	1306096	LOAD TABLE ASSY	27	2	NNK3/8-16	NUT, KEP, 3/8-16
4	1	13061003	MATERIAL OUT SENSOR FLAG STAND	28	4	SSBC90048	8-32 X 3/4 BUTTON CAP
5	2	13061006	MATERIAL OUT SENSOR FLAG	29	8	SSBC98040	10-32 X 5/8 BUTTON CAP SC
6	1	13061075	PNEUMATIC PANEL 1306	30	10	SSHC01032	1/4-20 X 1/2 HHCS
7	1	13061081	SUPPORT. CABLE BRIDGE	31	4	SSHC01048	1/4-20 X 3/4 HEX CAP
8	1	13061117	ELECTRIAL SUPPORT COMPONENTS	32	4	SSHC01112	1/4-20 X 1-3/4 HHCS
9	2	13061119	BRACKET, CABINET, LOWER SPRT	33	6	SSHC01128	1/4-20 X 2 HEX CAP
10	1	1306141	CART,PLASTIC ROLLS	34	2	SSHC25192	3/8-16 X 3 HEX CAP SC
11	1	13061459	PC MOUNT PLATE	35	2	SSHC98024	10-32 X 3/8 HEX CAP
12	1	1306377	LOWER COVEYOR ASSEMBLY	36	4	SSHC98048	SCREW, HEX CAP #10-32X.75
13	1	1306437	GUARD,RIGHT,UPPER	37	2	SSPS70048	4-40 X 3/4 PAN HD SLOTTED
14	2	1306461	GUARD,DOOR,FRONT,LEFT	38	2	SSZH#10032	SCREW,SHT.METAL HEX 10
15	1	1306462	GUARD, LEFT,UPPER	39	8	SSZS01080	SCREW,SHT.MTL,W/WASHER
16	2	1306720	SIDE GUARD	40	5	SSZS93032	SCREW, SHT.METAL 10 ZIP
17	1	1306805	ROLLER, PINCH ASSY UNDER	41	6	SSZS93048	SCREW, SHT.METAL 10 ZIP
18	*1	1306D-PD	DIAGRAM,PNEUMATIC,1306	42	2	WWF4	WASHER, FLAT, #4
19	2	13901091	SAFETY INTERLOCK SWITCH ASSY	43	34	WWFS1/4	WASHER,FLAT,SAE,1/4
20	1	1975-412A	PLATE,NUT,4-40,.95CTC	44	24	WWFS10	WASHER, FLAT, #10, SAE
21	2	98-6819	CORNER BRACKET	45	4	WWFS3/8	WASHER,FLAT,SAE,3/8
22	1	EEJBC375CG	GATEWAY PC, W-PWR CBL, SERIAL	46	14	WWL1/4	WASHER,LOCK, 1/4
23	1	FFSM312LVQ	EYE,ELECTRIC,10-30VDC	47	6	WWL10	WASHER,LOCK,#10
24	35 FT	MM5405K2	HOSE, AIR, 1/4" ID x 1/2" OD 200PSI				

1306096 Load Table Assembly
AAC Drawing Number 1306096 Rev 24

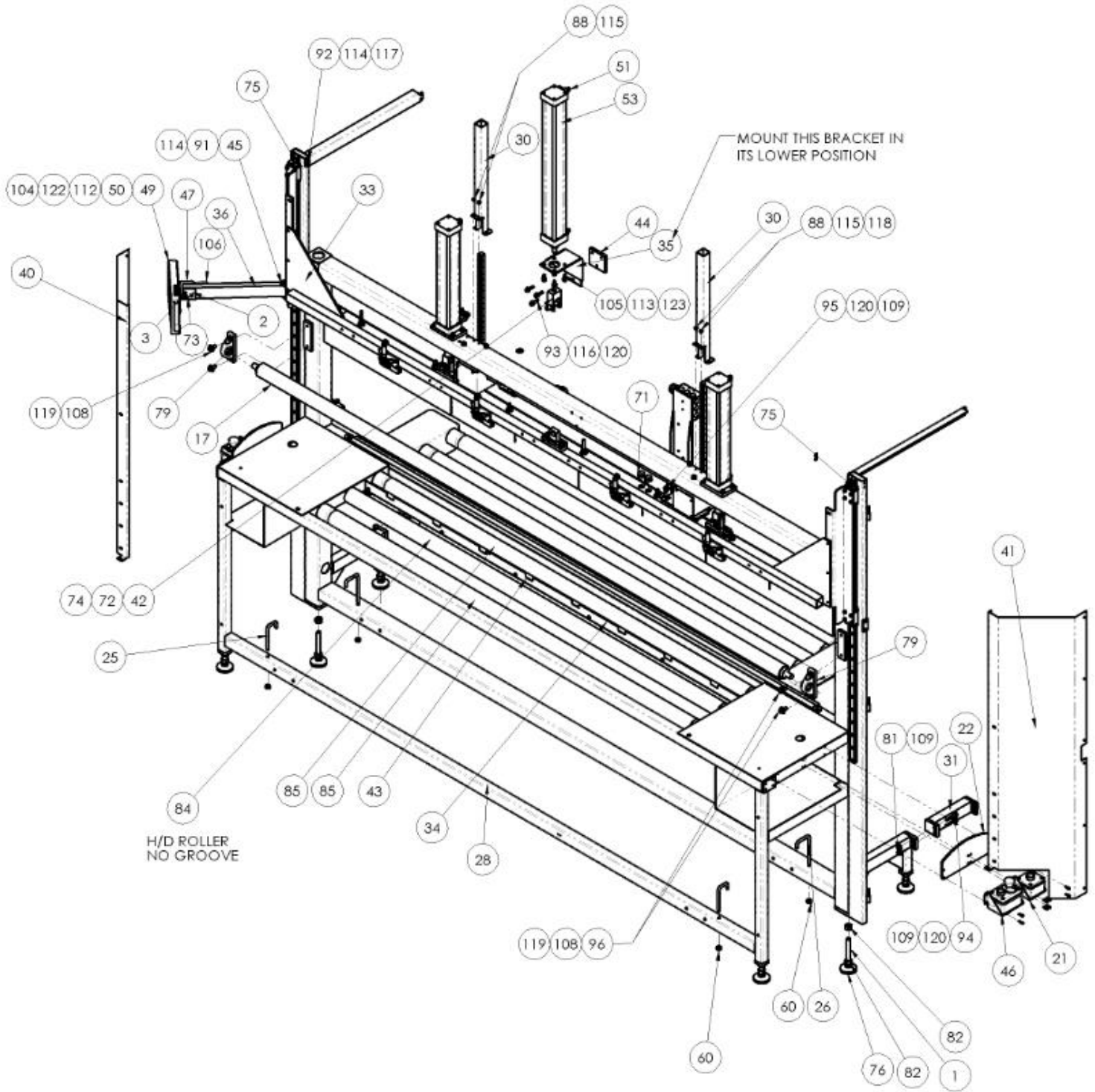

1306096 parts list

ITEM	QTY.	PART NUMBER	DESCRIPTION
1	6	0411-1063	ROD, THREADED, 5/8-11 X 5
2	1	0411-3708	NUT PLATE,BOX MOUNT
3	1	0411-3709	LOCK PIN
4	4	1306098	HEATER RACK GUIDE
5	2	1306099	RACK GEAR 12P 14.5PA 24"L
6	1	1306100	BALANCER CONNECTING ROD
7	1	1306103	FRONT BALANCER BRACKET
8	1	1306104	COVER PLATE GEAR BOX
9	1	1306105	GEAR BOX COVER
10	1	1306106	FRONT BALANCER BRACKET
11	1	1306107	GEAR BOX FRONT COVER
12	1	1306108	GEAR BOX RR COVER
13	2	1306113	CROSS SEAL CYL. MNT
14	2	1306114	CYLINDER MOUNT PLATE
15	1	1306117	CUTTING BAR ASSEMBLY
16	2	1306123	GEAR BOX SPACER
17	1	1306134	ROLLER ASSY, LOADING TBL
18	2	1306135	CYLINDER EXTENSION
19	1	1306136	COUPLING, 2 PIECE, 3/4 IN
20	1	1306142	BALANCER CONNECTING ROD
21	2	13061478	BUTTON BOX, START
22	2	13061480	GUARD,PUSH BUTTON, DOUBLE BOX
23	2	1306153	CUT BAR SEAT
24	2	1306154	FOAM ORANGE
25	2	1306160	CART RETAINER
26	2	1306162	CART RETAINER, REAR
27	1	1306166	BRACKET, J-BOX WELDMENT
28	1	1306167	CUTBAR WELDMENT
29	4	1306183	BRKT, MTG, FFS18S/E
30	2	1306186	LOADING TABLE RACK GAURD
31	2	1306190	TABLE CONNECTOR
32	2	1306302	SPUR GEAR 12P 18T 5/8B
33	1	1306583	CLAMP ASSEMBLY
34	1	1306587	CROSS BAR,FINGER MOUNT
35	1	1306592	MOUNT,CYLINDER,CLAMP
36	1	1306595	TUBE,16 L,PIVOT ARM
37	1	1306604	SUPPORT,TABLE,ROLLER MNT
38	1	1306605	SUPPORT,TABLE,ROLLER MNT
39	2	1306606	SPACER,TABLE MOUNT
40	1	1306633	GUARD,TABLE,FRONT,LEFT
41	1	1306634	GUARD,TABLE,FRONT,RIGHT

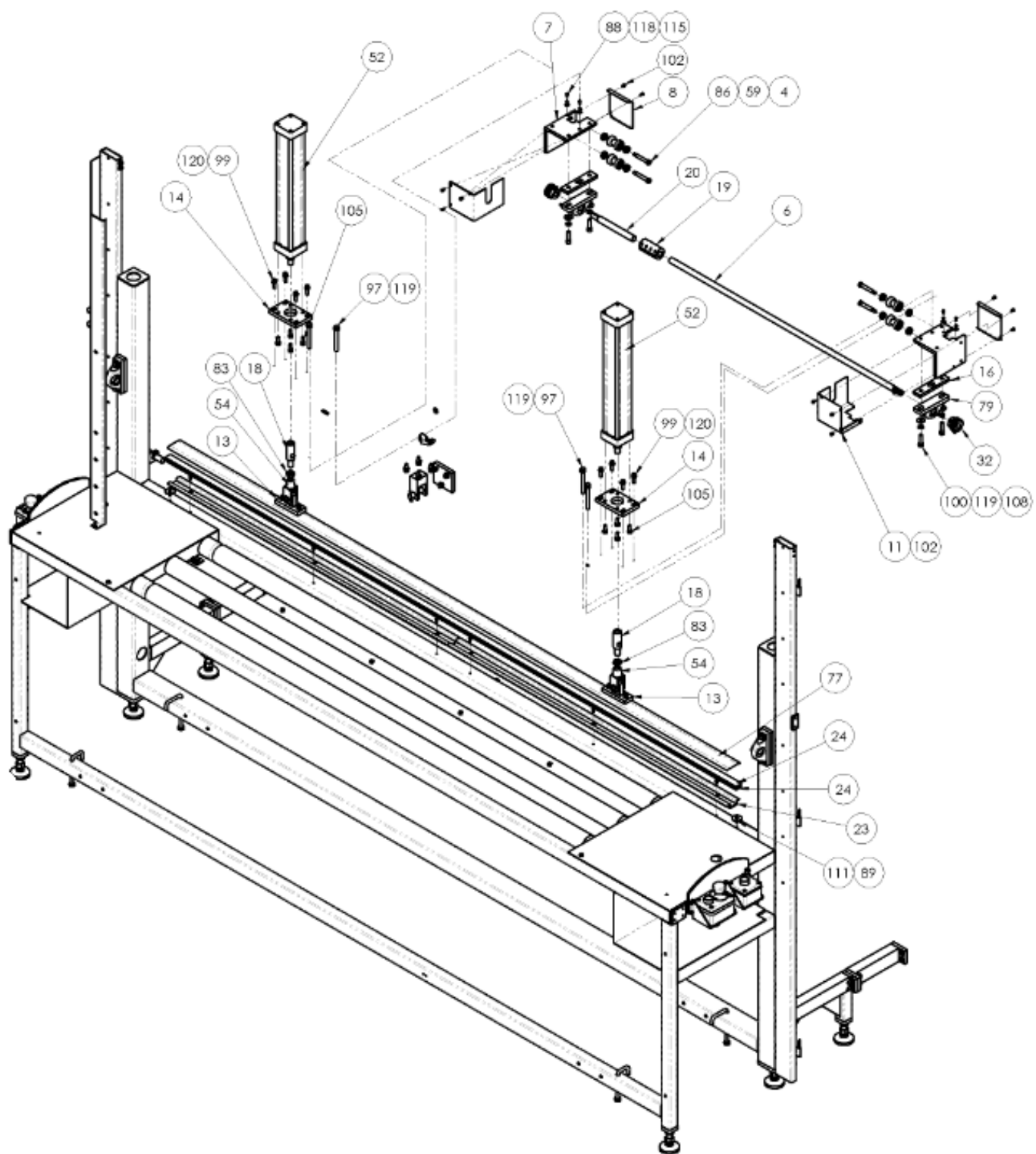

1306096 parts list
continued

ITEM	QTY.	PART NUMBER	DESCRIPTION
42	1	1306640	CLEVIS, M16X1.5
43	1	1306648	PLATE,FINGER,8 CLAMP
44	1	1306828	SPACER,BRACKET,CYL
45	1	1368286	BRACKET,SWIVEL ARM
46	2	13901054	BUTTON BOX, E-STOP/RESET
47	1	13901328	MOUNT, HMI, PC DISPLAY
48	2	1961-181	KEY, 3/16 X 1.00L
49	1	4082105	TOUCHSCREEN. 10", SUB ASSEMBL
50	1	4082105B	HMI BACKING PLATE, EEE10TSM
51	2	AA1983201FU0311	FLOW CONTL 3/8UNIFIT X3/8
52	2	AACSU63X400	CYLINDER, 63MMBX400MM
53	1	AACSU63X600	CYLINDER, 63MMBX600MM
54	2	AAFSGM16X1.5	CLEVIS ROD M16X1.5
55	1	AAQMC-3-3S	FITTING,STRT,3/8NPT,3/8
56	3	AAQME-3-3	MALE ELBOW 3/8OD X 3/8NPT
57	1	AAQME-5-8U	QUICK MALE ELBOW- UNIFIT
58	1	AAV78861717	VALVE, BLOCKING, R3/8
59	8	BB1L038	BEARING,BALL,.375B
60	4	CCSC6F3/8	COLLAR,SET 3/8
61	*2	FF221-612	SPLICING CONN,LEVERNUT,
62	1	FF3234	STRAIN RELIEF,3/4NPT
63	1	FF8465	NUT,LOCK, 3/4NPT,NYLON,BLK
64	1	FFQS186LEQ8	SENSOR,LASER EMITTER
65	1	FFQS18VN6RQ8	SENSOR,LASER RECEIVER,NPN
66	1	FFS186EQ	EYE,OPPOSED,XMIT,IR LED,
67	1	FFS18SN6RQ	EYE,OPPOSED,RCVR,NPN,IR
68	1	K-233	BOX,ELECTRICAL,SQUARE
69	1	K-234	COVER,4IN SQUARE
70	2	K-235	CONNECTOR,ROMEX,1/2"
71	2	MM9307K63	GROMMET,1/2ID,13/16 HOLE
72	1	MM97245A555C	CLEVIS PIN 2.75L, 2.5156 UL, .5 D
73	1	MM98335A04	SPRING CLIP, .06 WIRE
74	1	MM98338A225	COTTER PIN, 1/8 X 2 1/2
75	2	MMEGR25R1340C	RAIL,LINEAR, AG 1340MM
76	6	MML-2	LEVELING PAD, 5/8-11
77	1	MMSG1306	TAPE,TEFLON,3.4WX54FT
78	1	MMT9945-2	TAPE,REFLECTIVE,2" RED
79	4	MMVPS-112	BEARING,PILLOW BLOCK 3/4B
80	1	NNE1/4-20	NUT,ELASTIC LOCK,1/4-20
81	4	NNH5/16-18	NUT,HEX, 5/16-18
82	12	NNH5/8-11	NUT,HEX,5/8-11

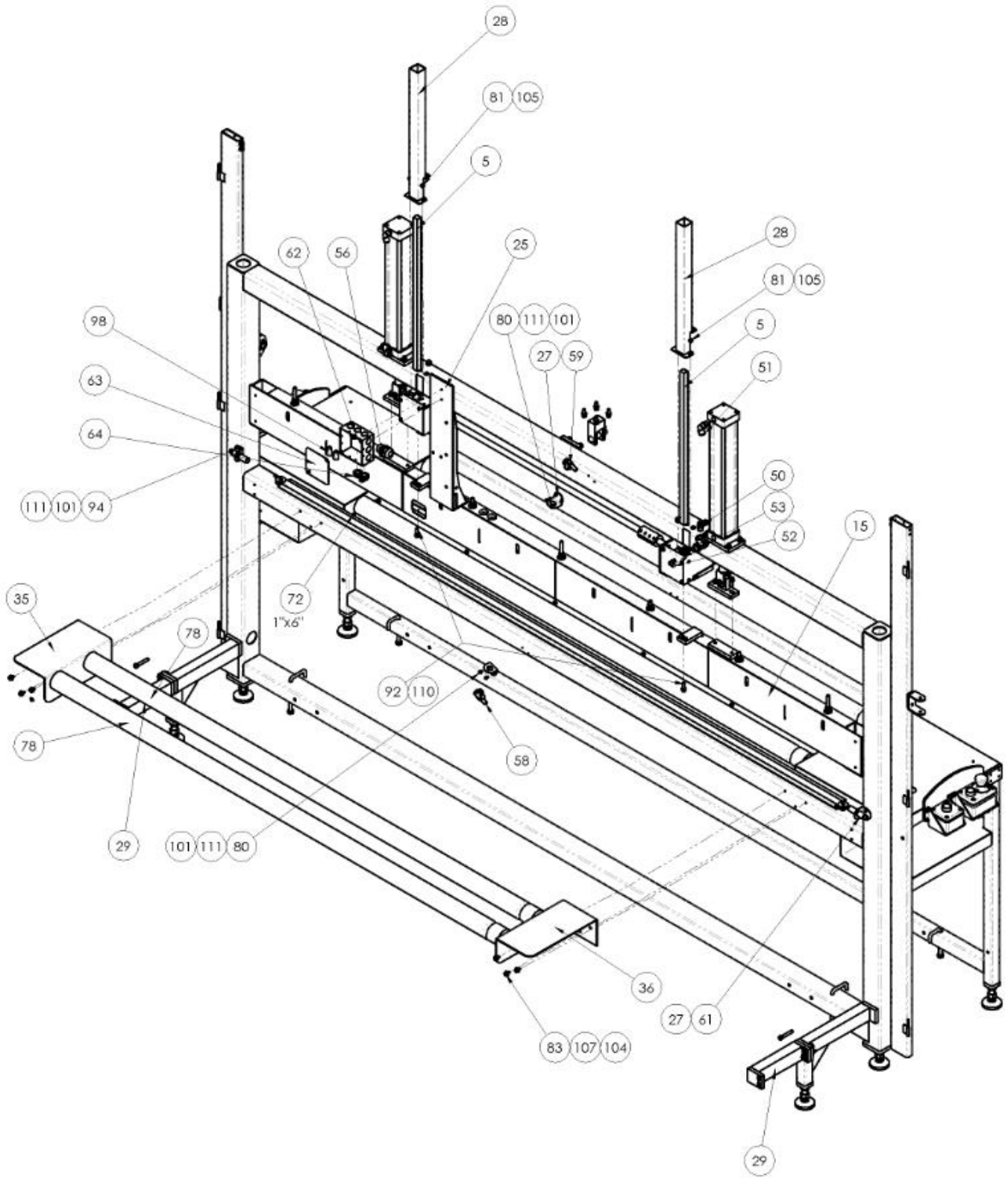

1306096 parts list
continued

ITEM	QTY.	PART NUMBER	DESCRIPTION
83	2	NNJM16X1.5	NUT,JAM,M16
84	1	RM44084HD	ROLLER,CONV,2.5"DIA,11ga
85	4	RM44084SG	ROLLER, 2.5"DIA, 80.5 L, SNGL GRV
86	4	SSAS024128	SHULDER BOLT 3/8 X 2.0L
87	4	SSBC90024	8-32X3/8 BUTTON CAP
88	14	SSBC98024	10-32 X 3/8 BUTTON CAP SC
89	2	SSBC98048	10-32 X 3/4 BUTTON CAP SC
90	6	SSHC01032	1/4-20 X 1/2 HHCS
91	1	SSHC01192	HEX HEAD BOLTS, 1/4-20 X 3
92	4	SSHC05032	1/4-28 X 1/2 HEX CAP
93	3	SSHC10080	HEX HEAD, 5/16-18 X 1-1/4
94	4	SSHC10128	SCREW, HEX, 5/16-18 X 2 HHCS
95	2	SSHC20048	5/16-24 X 3/4 HEX CAP
96	4	SSHC25064	3/8-16 X 1,HEX CAP
97	4	SSHC25224	3/8-16 X 3.5 HEX CAP
98	6	SSHC98024	10-32 X 3/8 HEX CAP
99	14	SSSC10064	5/16-18 X 1 SOCKET CAP
100	4	SSSC25088	3/8-16X1-3/8 SOC CAP
101	4	SSSC90024	8-32 X 3/8 SOC CAP SC
102	14	SSSC98016	10-32 X 1/4 SOC CAP
103	16	SSSC98040	10-32 X 5/8 SOC CAP
104	4	SSSCM3X16	M3-0.5X16 ,SOCKET CAP
105	12	SSSCM8X20	M8X20 SOC CAP
106	1	TTH32429	HANDLE,THRD,5/16-18X2.0
107	2	TTMB70476	CONNECTOR,WIRE,EX LARGE
108	8	WWF3/8	WASHER,FLAT,3/8 OR 10MM
109	10	WWF5/16	WASHER,FLAT,5/16
110	8	WWF8	WASHER, FLAT, #8
111	2	WWFE012	WASHER,FENDER,3/16
112	4	WWFM3	FLAT WASHER, M3
113	4	WWFM8	WASHER, FLAT, M8 I.D.
114	13	WWFS1/4	WASHER,FLAT,SAE,1/4
115	14	WWFS10	WASHER, FLAT, #10, SAE
116	3	WWFS5/16	WASHER,FLAT,SAE,5/16
117	10	WWL1/4	WASHER,LOCK, 1/4
118	30	WWL10	WASHER,LOCK,#10
119	12	WWL3/8	WASHER,LOCK, 3/8
120	23	WWL5/16	WASHER,LOCK, 5/16
121	8	WWL8	WASHER,LOCK,#8
122	4	WWLM3	WASHER, LOCK, M3
123	4	WWLM8	M8 LOCK WASHER

1306141 Cart, Plastic Rolls

AAC Drawing Number 1306141 Rev 1

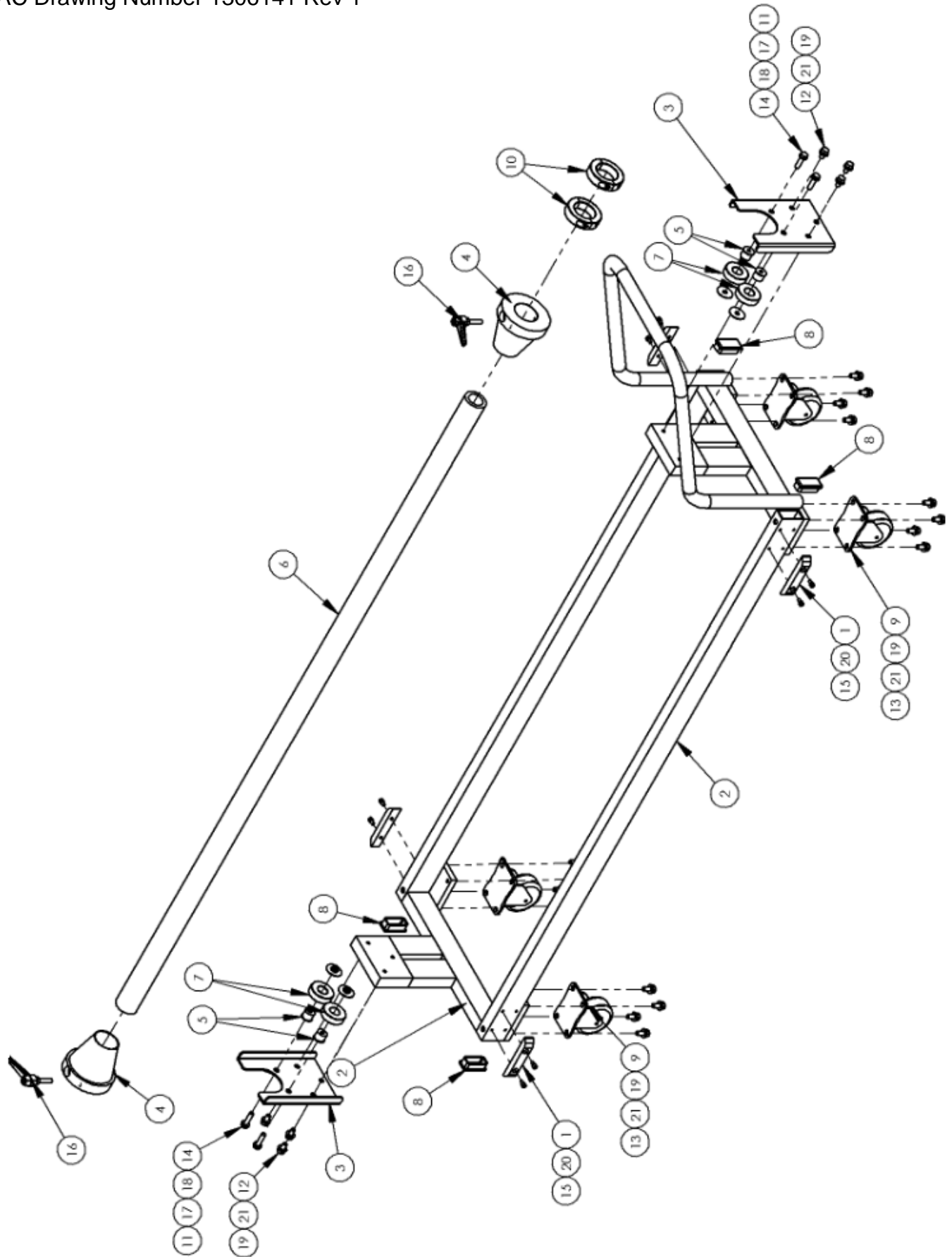

1306141 parts list

ITEM	QTY.	PART NUMBER	DESCRIPTION
1	4	1306129	BUMPER,CART
2	1	1306130	CART,FRAME,WELDMENT
3	2	1306137	BRACKET, ROLL HOLDER
4	2	1389928	CONE, 2 TO 3 1/4 1-7/8 BORE
5	4	1392476	BUSHING, BEARING MOUNT
6	1	1306140	BAR,ROLL HOLDER
7	4	BB1L017	BEARING,BALL,.787B
8	4	MM132-1496	PLUG 1 X 2
9	4	MM427-3RB	CASTER,SWIVEL,3"RUBBER
10	2	MM6436K25	COLLAR,SPLIT,1.75ID,2PC
11	4	NNJM8	NUT,JAM,M8,ZINC PLATED
12	6	SSHC10040	5/16-18 X 5/8 HHCS
13	16	SSHC10048	5/16-18 X 3/4 HHCS
14	4	SSHCM8X30	SCREW,HEX CAP M8X30
15	8	SSSC98024	10-32 X 3/8 SOC CAP
16	2	TTH32426	HANDLE,THRD,5/16-18X1-1/4
17	4	WWFE020	WASHER,FENDER,5/16
18	4	WWFM8	WASHER, FLAT, M8 I.D.
19	22	WWFS5/16	WASHER,FLAT,SAE,5/16
20	8	WWL10	WASHER,LOCK,#10
21	22	WWL5/16	WASHER,LOCK, 5/16

13061075 Pneumatic Panel

AAC Drawing Number 13061075 Rev 4

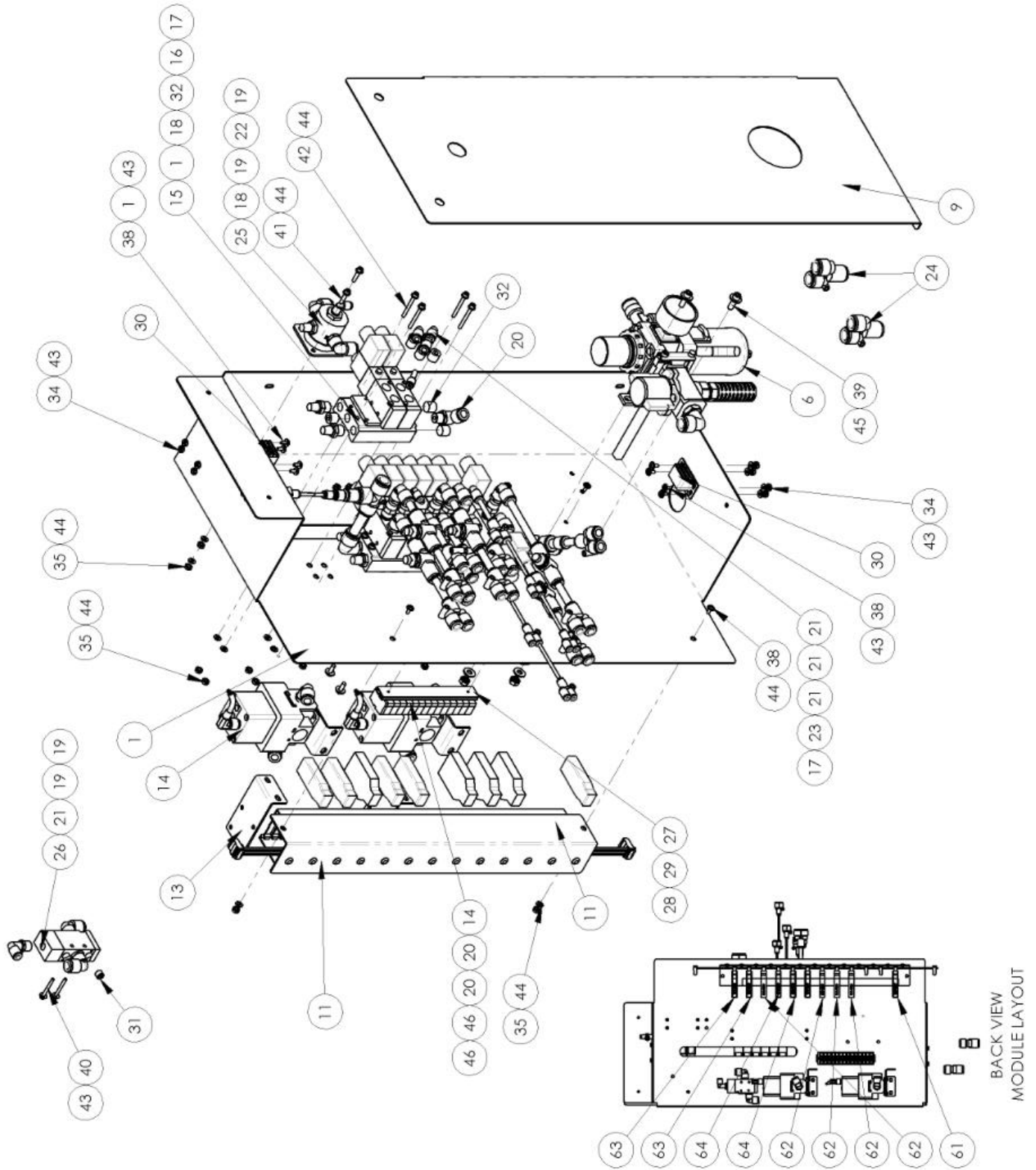

13061075 parts list

ITEM	QTY.	PART NUMBER	DESCRIPTION	ITEM	QTY.	PART NUMBER	DESCRIPTION
1	*2	1335-415	RESISTOR ARRAY	24	2	AAQY-2-2	QUICK UNION Y,1/2X1/2
2	4	4080-110	MODULE,QUAD INPUT	25	1	AAV250A	PILOT VALVE
3	3	4080-130	MODULE,QUAD OPTO-ISO	26	1	AAV250B	VALVE, PILOT, 1/4" NPT
4	2	4080-140	MODULE,QUAD OUTPUT	27	1	FF264-3BKT6	MOUNT, WAGO TERMINAL
5	1	4080-200	MODULE,AIR PRESSURE	28	14	FF264-341	TERMBLK,WAGO,TOP,DUAL,GRY
6	1	1306327	MAIN REGULATOR ASSEMBLY	29	1	FF264-371	TERMBLK,WAGO,TOP,END
1	1	13061071	PNEUMATIC PANEL, 1306 UPGRADE	30	2	MM1676A12	MAGNETIC CATCH
8	1	13061075-CAB	CABLE, PACKAGE 1306D	31	1	MM4554K11	PLUG, 1/8" PIPE
9	1	13061076	COVER, PNEUMATIC PANEL	32	5	MM4554K12	PLUG, 1/4" PIPE
10	1	13061078	VALVE STACK ASSY, 7	33	2	NNK1/4-20	NUT,KEP,1/4-20
11	1	13061079	MOUNTING STATION - SBUS - 12 POS	34	10	NNK6-32	KEP NUT, 6-32
12	2	13061104	CABLE, OPTO-ISO, W/PWR, 12 "	35	12	NNK8-32	NUT,KEP,8-32
13	2	13061236	REG BRACKET, RT ANDLE MOUNT	36	4	NNK10-32	KEP NUT, 10-32
14	2	AA198-3050A	REGULATOR,ELECTRO/PNEUM	37	4	SSHC98032	10-32X1/2 HEX HD
15	1	AAE4V200M3F	MANIFOLD,3 STATION	38	12	SSPP80024	#6-32X3/8 PAN PHILLIPS
16	1	AAE4V200MB	MANIFOLD, BLANK PLATE	39	2	SSSC01048	1/4-20 X 3/4" SOC CAP SC
17	2	AAE4V21008	VALVE, 1/4" PORTED, 24VDC	40	2	SSSC80080	6-32 X 1-1/4 SOC CAP SC
18	3	AAFP28	MUFFLER,1/4 NPT	41	2	SSSC90048	#8-32 X 3/4 SOC CAP SC
19	4	AAQME-3-4	ELBOW MALE,Q, 3/8 TUBE, 1/4 NPT	42	8	SSSC90096	#8-32 X 1-1/2 SOC CAP SC
20	5	AAQME-4-3S	FITTING,ELBOW,1/4NPT,3/8	43	22	WWF6S	WASHER, FLAT, #6
21	4	AAQME-4-4	ELBOW, MALE,Q, 1/4 TUBE, 1/4 NPT	44	24	WWF8	WASHER, FLAT, #8
22	1	AAQME-5-8	ELBOW MALE,Q,5/32 TUBE, 1/8NPT	45	4	WWFS1/4	WASHER,FLAT,SAE,1/4
23	1	AAQPR-5-4	REDUCER, QUICK, 1/4- 5/32	46	8	WWFS10	WASHER, FLAT, # 10, SAE

13901091 Safety Interlock Switch Assembly

AAC Drawing Number 13901091 Rev 2

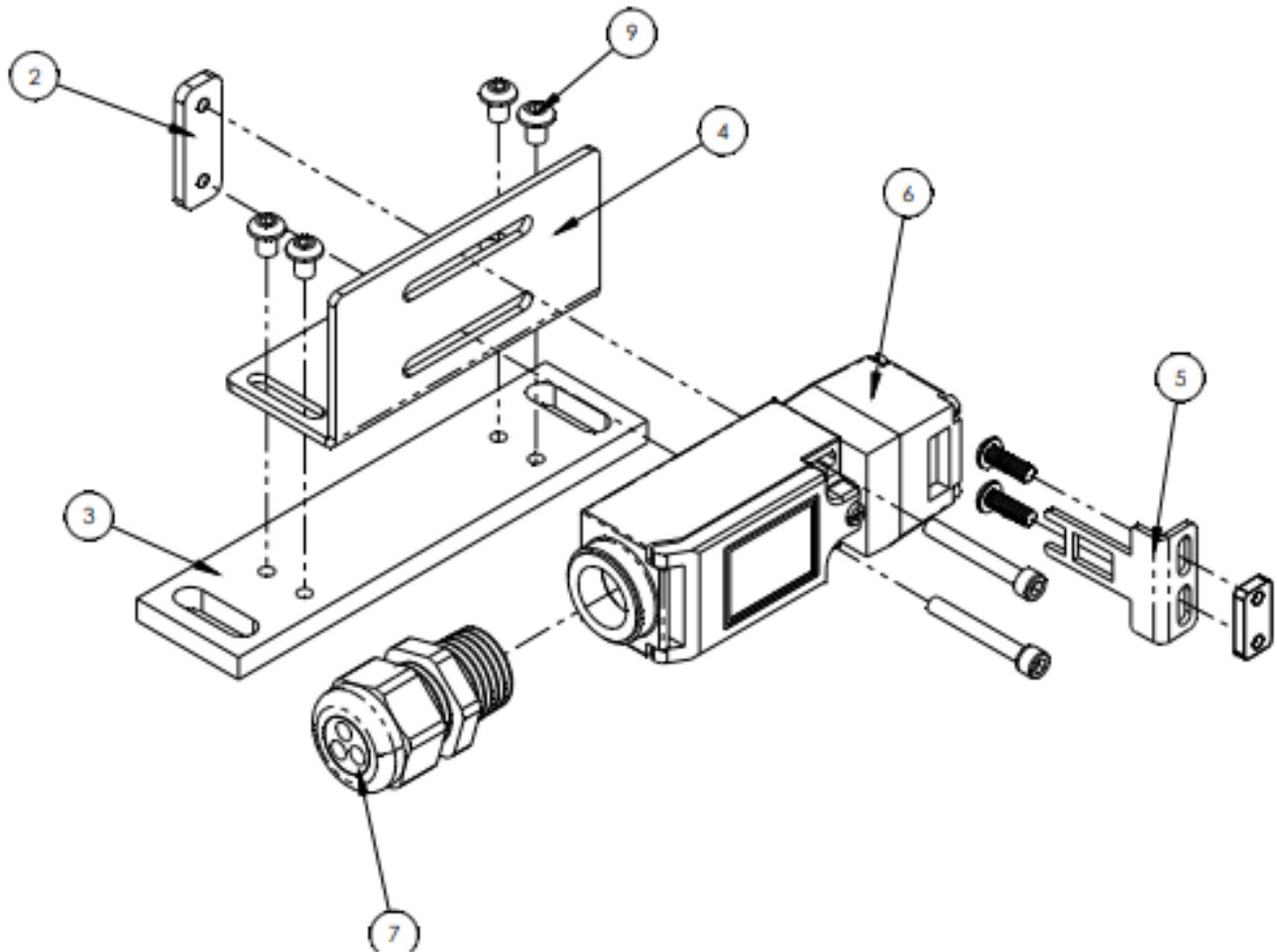

ITEM	QTY.	PART NUMBER	DESCRIPTION
1	1	1060008	PLATE,NUT,8-32X.50
2	1	1307374	PLATE, NUT, 8-32 X 22MM CTC X 10 GA
3	1	1318377	SAFETY SWITCH MOUNT
4	1	13901092	SAFETY SW MNT FOR EEIDIS190051
5	1	EE140103	KEY,SAFETY SW,IDIS,90 DEG
6	1	EEIDIS190051	SWITCH, SAFETY, DOOR.
7	1	FFM3200GAH-SM	STRAIN RELIEF, 1/2NPT, 3 HOLE, BLK
8	2	SSBC90032	8-32X1/2 BUTTON CAP
9	4	SSBC98016	10-32 X 1/4 BUTTON CAP SC
10	2	SSSC90080	#8-32 X 1-1/4 SOC CAP SC
11	2	WWL6	WASHER,LOCK,#6

1306079 Top Compression Assembly

AAC Drawing Number 1306079 Rev 3

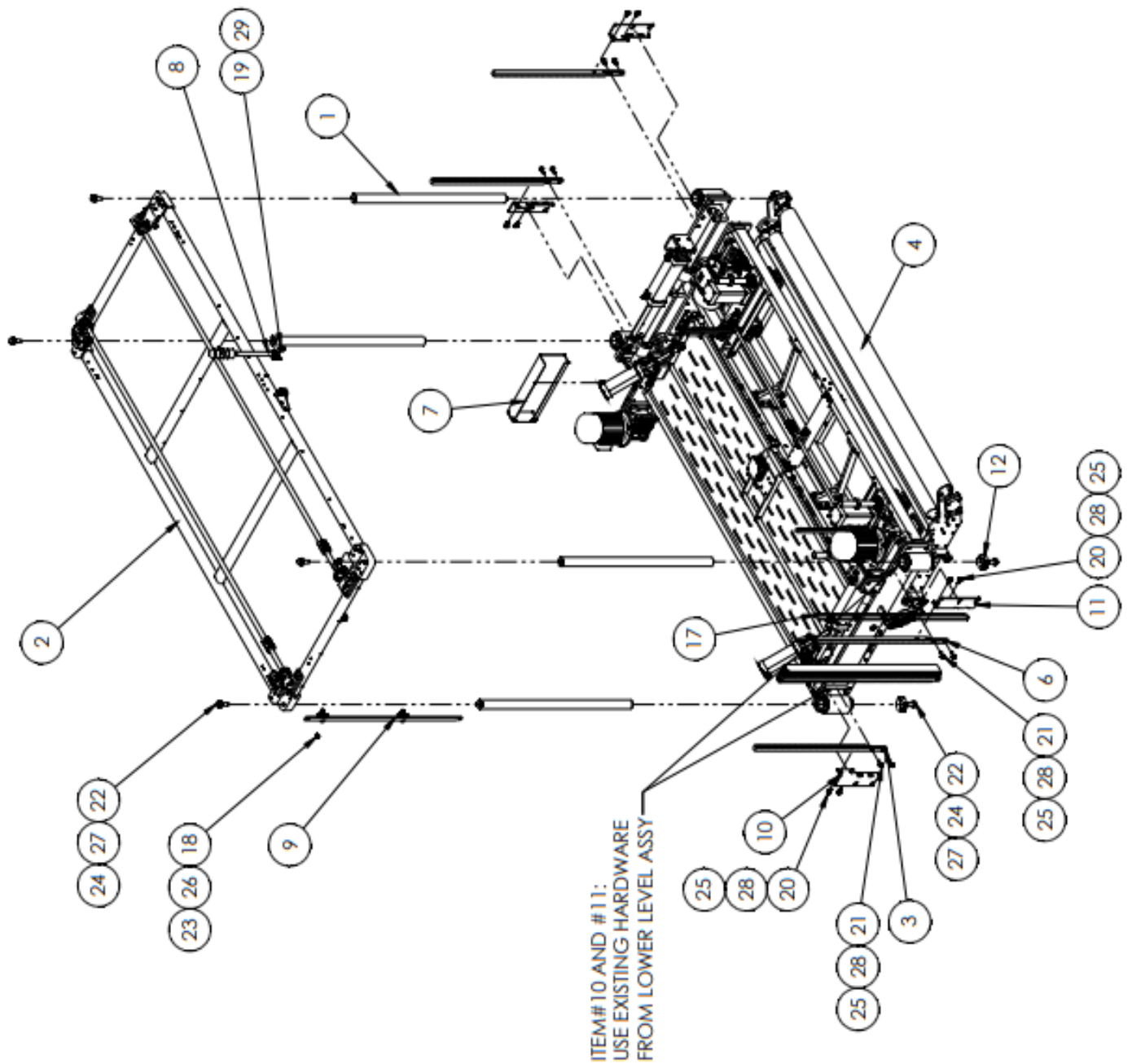

1306079 parts list

ITEM	QTY	PART NUMBER	DESCRIPTION	ITEM	QTY	PART NUMBER	DESCRIPTION
1	4	1306070	RAIL, LINEAR, ROUND,2"	16	*42"	EEDF2X2	DUCT,WIRE,2X2, MOD
2	1	1306077	TOP SUPPORT FRAME	17	1	GG850XL037	BELT,GEAR,1/5P,3/8W,425T
3	2	1306080	GEAR RACK, 10DP, 1" FACE	18	1	SSHC01032	1/4-20 X 1/2 HHCS
4	1	1306280	PRESSING CONVEYOR ASBLY	19	2	SSHC10032	5/16-18 X 1/2 HHCS
5	1	1306290	MOUNT,WIRE HARNESS	20	8	SSHC25064	3/8-16 X 1,HEX CAP
6	2	1306336	GEAR RACK, 10DP, 1" FACE	21	8	SSHC25080	3/8-16X1-1/4 HHCS
7	1	1306442	GUARD,DRIVE,REAR	22	8	SSHC34128	3/4-10 X 2 HEX CAP
8	1	1306615	LIGHT ASSEMBLY	23	1	WWFS1/4	WASHER,FLAT,SAE,1/4
9	1	13061118	BRACKET, SENSOR ASSM	24	8	WWFS3/4	WASHER, .797ID X 1-1/2OD
10	2	13061475	RACK (1306080) REINFORCEMENT BRKT	25	16	WWFS3/8	WASHER,FLAT,SAE,3/8
11	2	13061476	RACK (1306336) REINFORCEMENT BRKT	26	1	WWL1/4	WASHER,LOCK, 1/4
12	4	CCCL32	COLLAR, SPLIT,2" ID	27	8	WWL3/4	3/4 LOCK WASHER
13	*42"	EEDC1LG	DUCT,WIRE COVER,1"	28	16	WWL3/8	WASHER,LOCK, 3/8
14	*42"	EEDC2X2	COVER,WIRE DUCT	29	2	WWL5/16	WASHER,LOCK, 5/16
15	*42"	EEDF1X1	DUCT,WIRE,1X1				

1306077 Pressing Conveyor Assembly

AAC Drawing Number 1306077 Rev 6

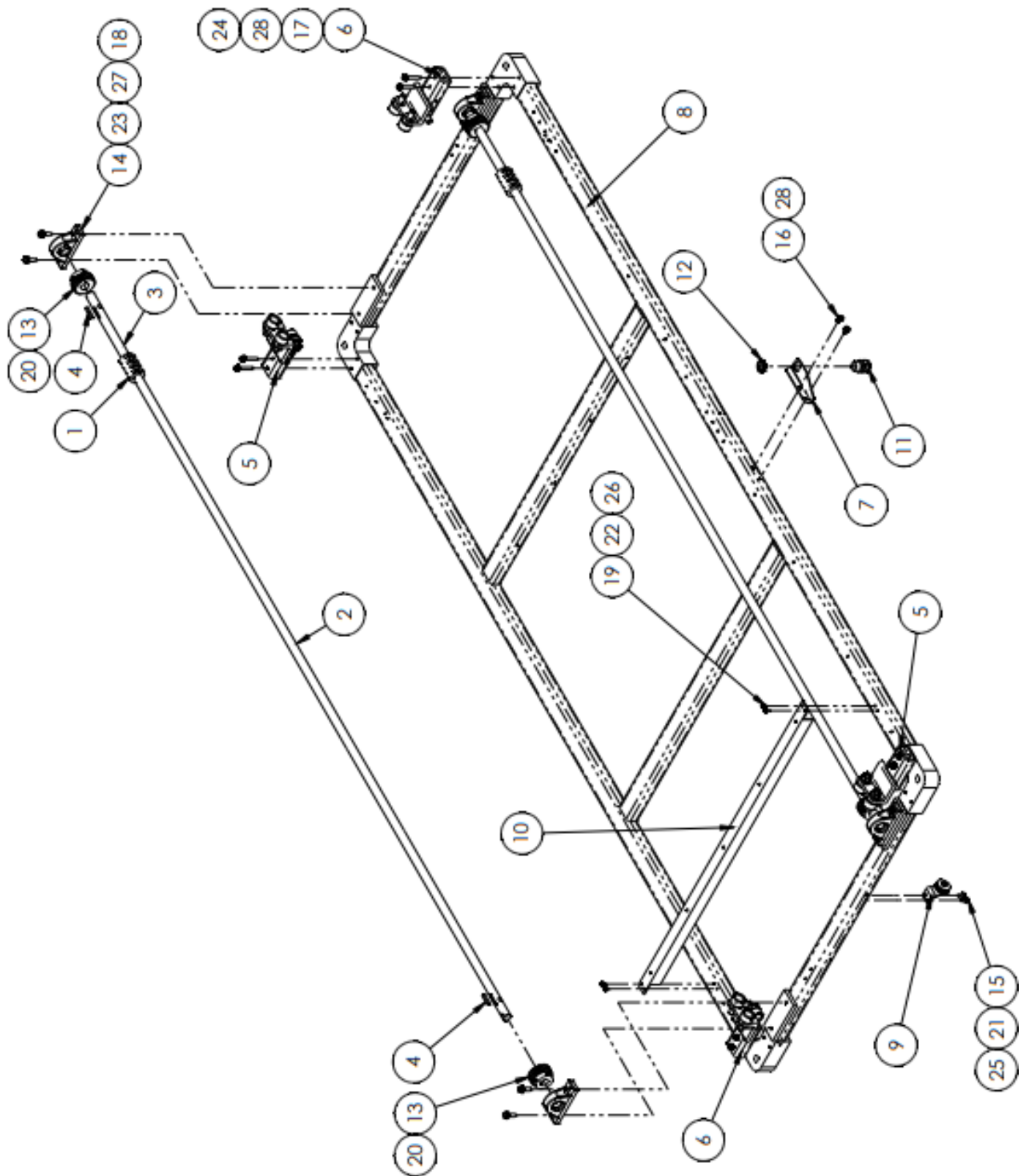

1306077 parts list

ITEM	QTY.	PART NUMBER	DESCRIPTION	ITEM	QTY.	PART NUMBER	DESCRIPTION
1	2	1306082	COUPLING,2-PIECE,1" BORE	15	2	SSH01048	1/4-20 X 3/4 HEX CAP
2	2	1306083	SHAFT, TRANSFER, LONG	16	2	SSH010032	5/16-18 X 1/2 HHCS
3	2	1306084	SHAFT, TRANSFER, SHORT	17	8	SSH010128	SCREW, HEX, 5/16-18 X 2 HHCS
4	4	1306086	KEY,1/4 X 1/4 X 1.61L	18	8	SSH025080	3/8-16X1-1/4 HHCS
5	2	13061214	GEAR RACK GUIDE, RH	19	4	SSH095032	10-24 X .5, HEX CAP
6	2	13061218	GEAR RACK GUIDE, LH	20	7	SS010032	SCREW,SKT SET,KNURL PT
7	1	1306168	BRACKET,HEATER WIRE	21	2	WWFS1/4	WASHER,FLAT,SAE,1/4
8	1	1306426	FRAME, SUPPORT, UPPER	22	4	WWFS10	WASHER, FLAT, #10, SAE
9	1	1306600	PULLEY,IDLER,ASSEMBLY	23	8	WWFS3/8	WASHER,FLAT,SAE,3/8
10	1	1306757	HRS ANGLE BABLE SUPPORT	24	8	WWFS5/16	WASHER,FLAT,SAE,5/16
11	1	FF3234	STRAIN RELIEF,3/4NPT	25	2	WWL1/4	WASHER,LOCK, 1/4
12	1	FF8465	NUT,LOCK, 3/4NPT,NYLON,BLK	26	4	WWL10	WASHER,LOCK,#10
13	4	MMNSS10F24-1M	GEAR,SPUR,10P,1 B W/KEY	27	8	WWL3/8	WASHER,LOCK, 3/8
14	4	MMVPLS-116	BEARING,FILLOW BLOCK 1.00	28	10	WWL5/16	WASHER,LOCK, 5/16

1306280 Pressing conveyor Assembly

AAC Drawing Number 1306280 Rev 12

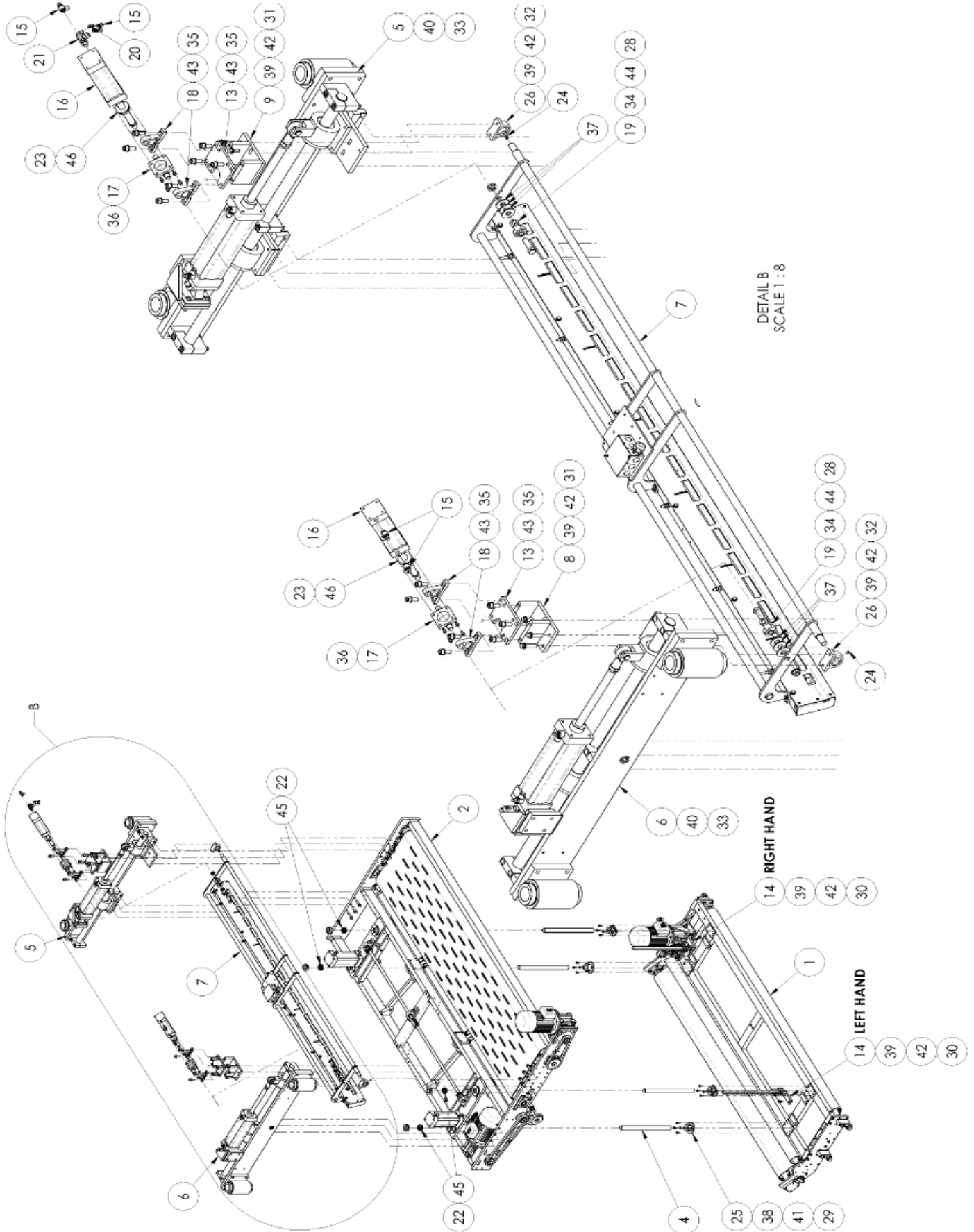

1306280 parts list

ITEM	QTY.	PART NUMBER	DESCRIPTION	ITEM	QTY.	PART NUMBER	DESCRIPTION
1	1	1306211	CONVEYOR, UPPER	24	2	MM10595K14	FITTING,GREASE,1/4-28,FLS
2	1	1306229	MAIN PRESSING ASBLY	25	2	MM1870K7	FLANGE, MTG, 1 1/4 BORE
3	2	1306281	MOUNT, CLEVIS	26	2	MMUCA204-12	BEARING, PILLOW BLK, .75B
4	4	1306288	SHAFT, GUIDE, UPPER CONV	27	12	NNJ1/2-13	NUT,JAM, 1/2-13
5	1	1306308	CARRIAGE,LEFT,UPR CNVYR	28	2	NNJM16X1.5	NUT,JAM,M16
6	1	1306334	CARRIAGE,RIGHT,UPR CNVYR	29	16	SSHC01064	1/4-20 X 1 HHCS
7	1	1306393	SEAL BAR ASSEMBLY, 86"	30	8	SSHC25064	3/8-16 X 1,HEX CAP
8	1	1306409	MOUNT,REAR HS CYLINDER,R	31	2	SSHC25080	3/8-16X1-1/4 HHCS
9	1	1306411	MOUNT,REAR,HS CYLINDER,L	32	4	SSHC25128	3/8-16 X 2 HEX CAP
10	1	1306602	MOUNT,BELT,POSITIONING	33	12	SSHC45128	1/2-13 X 2,HEX CAP
11	1	1306603	PLATE,BELT RETAINER	34	2	SSHCM16X50	M16-2.0x50, HEX CAP
12	2	1306751	FLANGE, MTG, 1 1/4 B, MOD	35	14	SSSCM12X30	SCREW, SOC CAP, M12 X 30
13	2	1306781	SEAL BAR CYL MOUNT	36	8	SSSCM6X16	M6 X 16, SOC CAP
14	2	1306987	GEAR RACK ASSY, B/B	37	6	WWF5/8	WASHER,FLAT,5/8
15	4	AA198RA404U	FLOW CONTROL,1/4PTX1/4	38	16	WWFS1/4	WASHER,FLAT,SAE,1/4
16	2	AACESI50X150	CYLINDER,AIR 50MM BORE	39	10	WWFS3/8	WASHER,FLAT,SAE,3/8
17	2	AACSU50FTC	TRUNION MOUNT, 50MM BORE	40	12	WWL1/2	1/2 LOCK WASHER
18	2	AACSU50TCM1	PIVOT MOUNT, PAIR, 50MM BORE	41	16	WWL1/4	WASHER,LOCK, 1/4
19	2	AAFSGSM16x15	BEARING,ROD END,16MM	42	14	WWL3/8	WASHER,LOCK, 3/8
20	1	AAQME-5-10	AIR ELBOW, 10-32 X 5/32	43	14	WWLM12	M12 LOCK WASHER
21	1	AAV78861414	V ALVE, BLOCKING, R1/4	44	2	WWLM16	M16 LOCK WASHER
22	4	CCCL20F	COLLAR,1 1/4" CLAMP TYPE	45	4	WWSB1-3/4	SPRING, WAVE
23	2	CCCLMSP20F	CLAMP COLLAR- M20	46	2	WWU20MM	WASHER,URETHANE,20MM ID

1306211 Conveyor, Upper

AAC Drawing Number 1306211 Rev6

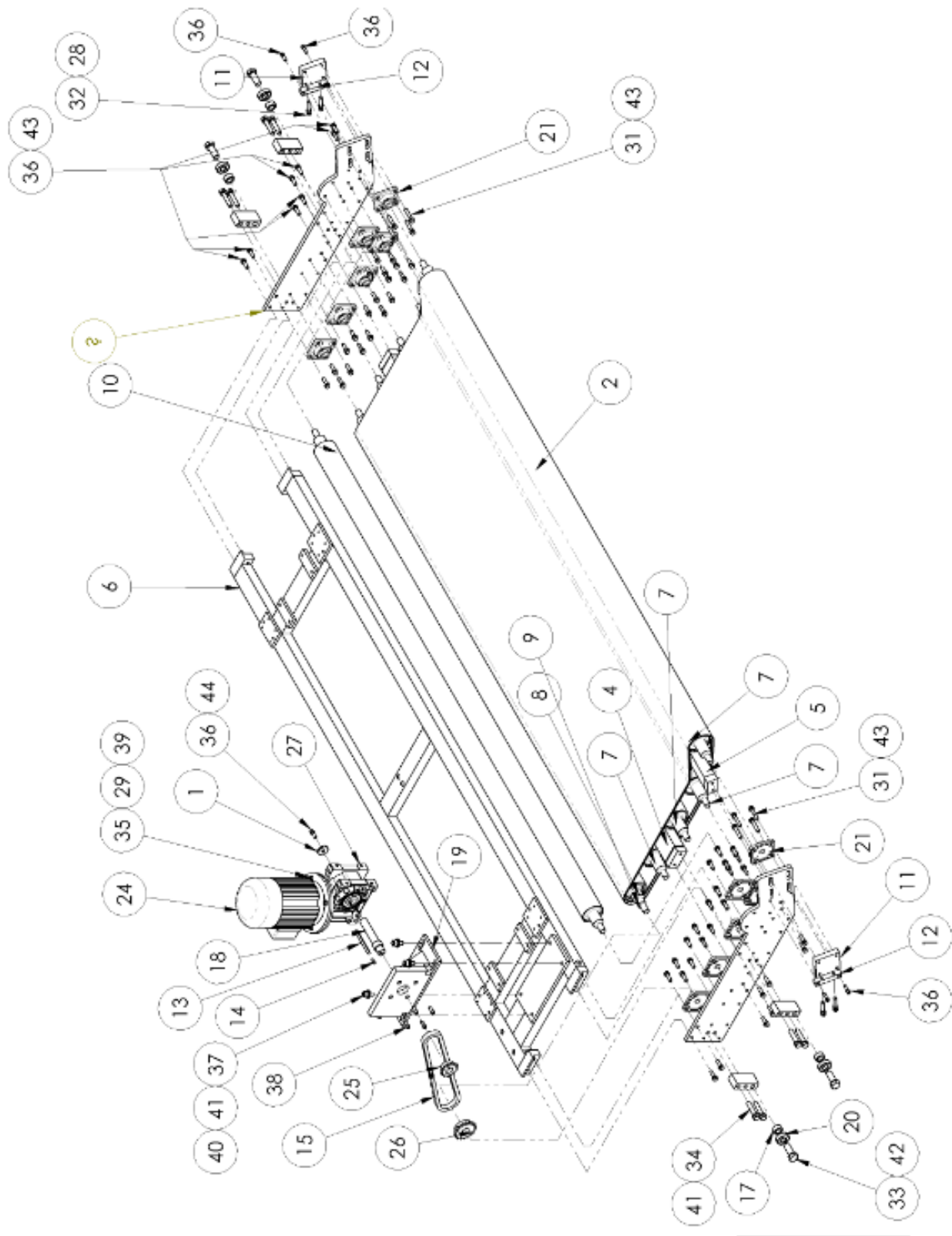

1306211 parts list

ITEM	QTY.	PART NUMBER	DESCRIPTION	ITEM	QTY.	PART NUMBER	DESCRIPTION
1	1	1306005	RETAINER,SHAFT,GEARBOX	23	1	FF8463	NUT,LOCK,1/2NPT,NYLON,BLK
2	1	1306197	UPPER FRONT CONVEYOR BELT	24	1	MM90L4B5	MOTOR,1.5KW,IEC,B5,2HP
3	2	1306207	PLATE, SIDE, UPPER CONV	25	1	MMH4014X1	SPROCKET,#40,14T,1"B
4	1	1306208	TUBE, SUPPORT, CROSS	26	1	MMH4018X1	SPROCKET,#40,18T,1"B
5	1	1306209	TUBE, SUPPORT, CROSS	27	1	MMRV6330D90	GEARBOX,WORM,RV63,30:1
6	1	1306210	FRAME,SUPPORT,UPPER CONV	28	4	NNH3/8-16	NUT,HEX,3/8-16
7	4	1306215	ROLLER, IDLER, UPPER CONV	29	AR	NNHM8X1.25	M8 X 1.25 HEX NUT
8	1	1306216	ROLLER, DRIVE, UPPER CONV	30	56	SSHC25080	3/8-16X1-1/4 HHCS
9	1	1306219	KEY,1/4X1/4X.95L	31	8	SSHC25128	3/8-16 X 2 HEX CAP
10	1	1306220	ROLLER, IDLER, UPPER CONV	32	4	SSHC25144F	3/8-16X2-1/4 HEX CAP SC
11	2	1306221	PLATE, NUT, BELT TENSION	33	4	SSHC34128	3/4-10 X 2 HEX CAP
12	2	1306222	BAR, TENSION SCREW	34	8	SSHC45160	1/2-13X2-1/2 HEX CAP
13	1	1306240	KEY,5/16X5/16X4.15L	35	AR	SSHCM8X30	SCREW,HEX CAP M8X30
14	1	1306241	KEY, 1/4 X 1/4 X .75	36	5	SSSC10064	5/16-18 X 1 SOCKET CAP
15	1	1306292	DRIVE CHAIN, UPPER CONV	37	4	SSSC45064	SCREW,SOC CAP,1/2-13 X 1"
16	4	1306612	MOUNT,GUIDE,BEARING	38	4	SSSCM8X20	M8X20 SOC CAP
17	4	1306613	SPACER, BEARING SUPPORT	39	AR	WWFM8	WASHER, FLAT, M8 I.D.
18	1	1306721	SHAFT, DRIVE, UPPER CONV	40	4	WWFS1/2	WASHER,FLAT,1/2, SAE
19	1	1306725	MOUNT, MOTOR, UPPER CONV	41	12	WWL1/2	1/2 LOCK WASHER
20	4	BB2281288	BEARING,BALL,.75 ID	42	4	WWL3/4	3/4 LOCK WASHER
21	12	BBUCF204-12	BEARING,FLANGE,.75B	43	65	WWL3/8	WASHER,LOCK,3/8
22	1	FF3200	STRAIN RELIEF,1/2NPT	44	1	WWL5/16	WASHER,LOCK,5/16

1306229 Main Pressing Assembly
AAC Drawing Number 1306229 Rev 13

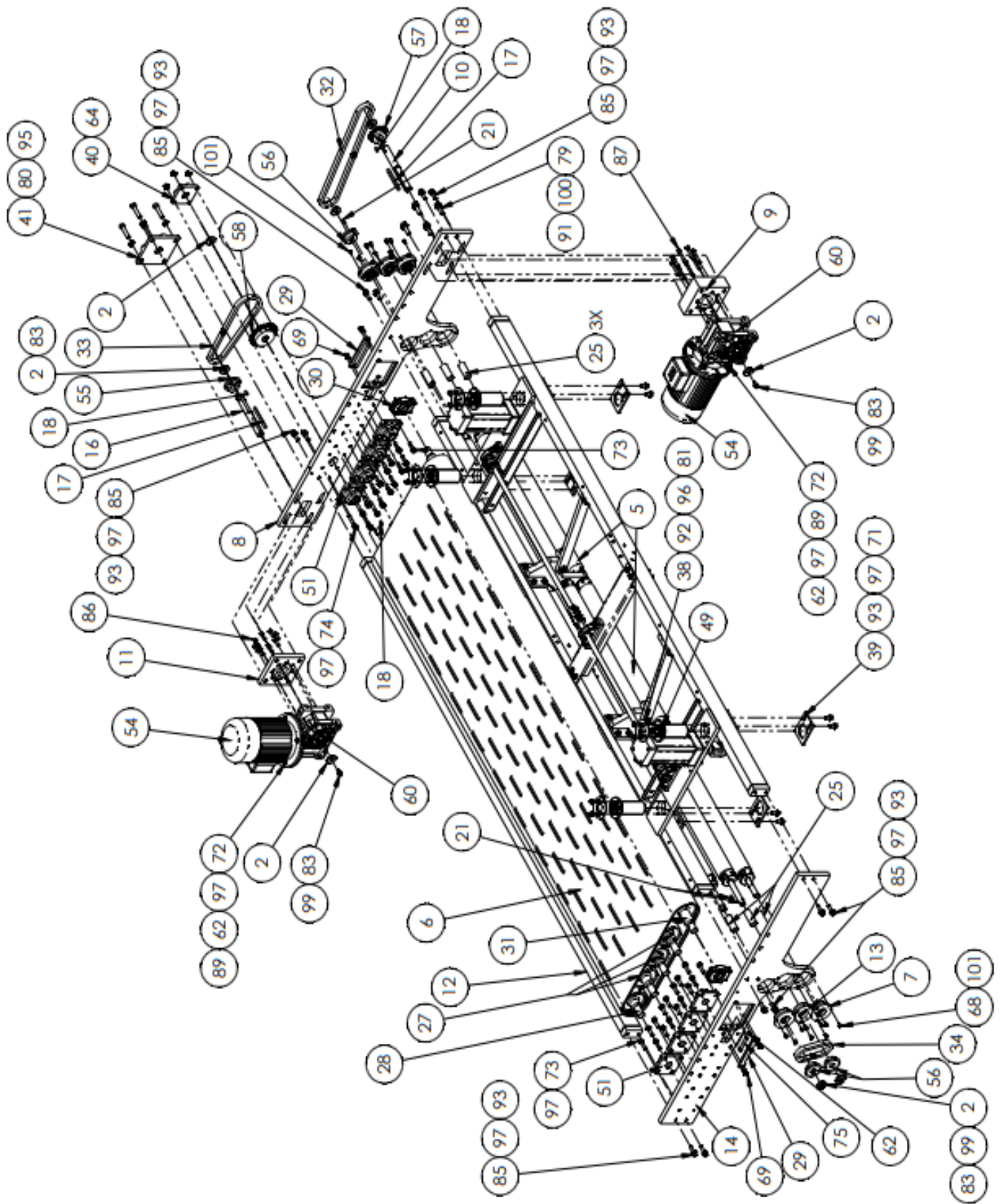

1306229 parts list

ITEM	QTY.	PART NUMBER	DESCRIPTION	ITEM	QTY.	PART NUMBER	DESCRIPTION
1	2	1961-181	KEY, 3/16 X 1.00L	27	3	1306272	ROLLER,SUPPORT,REAR CONV
2	8	1306005	RETAINER,SHAFT,GEARBOX	28	1	1306273	ROLLER,DRIVE,REAR CONV
3	2	1306098	HEATER RACK GUIDE	29	2	1306276	RETAINER, BEARING
4	1	1306136	COUPLING, 2 PIECE, 3/4 IN	30	2	1306277	BEARING, TAKE-UP, 1", MOD
5	3	1306165	TURNING ROLLER, PLAIN	31	1	1306278	ROLLER,TENSION,REAR CONV
6	1	1306198	BELT, CONVEYOR, UPPER	32	1	1306298	DRIVE CHAIN, TURN ROLLER
7	4	1306224	BEARING HOUSING	33	1	1306299	DRIVE CHAIN, REAR CONV
8	1	1306226	PLATE,SIDE,REAR CONV,RT	34	1	1306300	TRANS CHAIN, TURN ROLLER
9	1	1306227	BLOCK, SPACER, MOTOR	35	2	1306303	SHAFT, TRANSFER
10	1	1306228	SHAFT, DRIVE, REAR ROLLER	36	6	1306392	TURNING ROLLER, RUBBER
11	1	1306230	BLOCK, SPACER, MOTOR	37	1	1306632	SHAFT, ROLLER, IDLER
12	1	1306233	CROSS SUPPORT TUBE	38	4	1306772	WASHER, SHAFT
13	2	1306234	BEARING HOUSING, MIDDLE	39	4	1306963	LOWER BEARING GUIDE, SMALL
14	1	1306235	PLATE,SIDE,REAR CONV,LT	40	1	1306995	BEARING MT ASSEMBLY
15	1	1306236	FRAME, PRESSER SUPPORT	41	1	1306998	BEARING MT ASSEMBLY
16	1	1306239	SHAFT, DRIVE, REAR CONV	42	1	1307190	CENTER BEARING SUPPORT
17	2	1306240	KEY,5/16X5/16X4.15L	43	6	1307345	SPACER,.75 IDX1.0X.72L
18	3	1306241	KEY, 1/4 X 1/4 X .75	44	6	1307346	SPACER,.75 IDX1.0X.23L
19	1	1306242	SHAFT, ROLLER, DRIVEN	45	2	AACSU80X150	CYLINDER,80MMB,1.50S
20	1	1306243	SHAFT, ROLLER, DRIVEN	46	2	AAFSGM20X15	CLEVIS,ROD,M20 X 1.5
21	3	1306244	KEY, 3/16 X.75 LG	47	4	AAQME-3-3	MALE ELBOW 3/8 OD TUBE
22	2	1306247	PLATE, NUT,3/8-16X4	48	4	BB1L038	BEARING,BALL,.375B
23	1	1306249	MOUNT,BEARING,CENTER,RT	49	4	BB6483K77	BEARING,LINEAR,DBL,1.25B
24	1	1306250	MOUNT,BEARING,CENTER,LT	50	6	BB2281288	BEARING,BALL,.75 ID
25	6	1306254	SPACER, ROLLER	51	8	BBFB250-1	BEARING,BALL,FLNG BLK,1"B
26	2	1306264	ARM ADJ. SUPPORT				

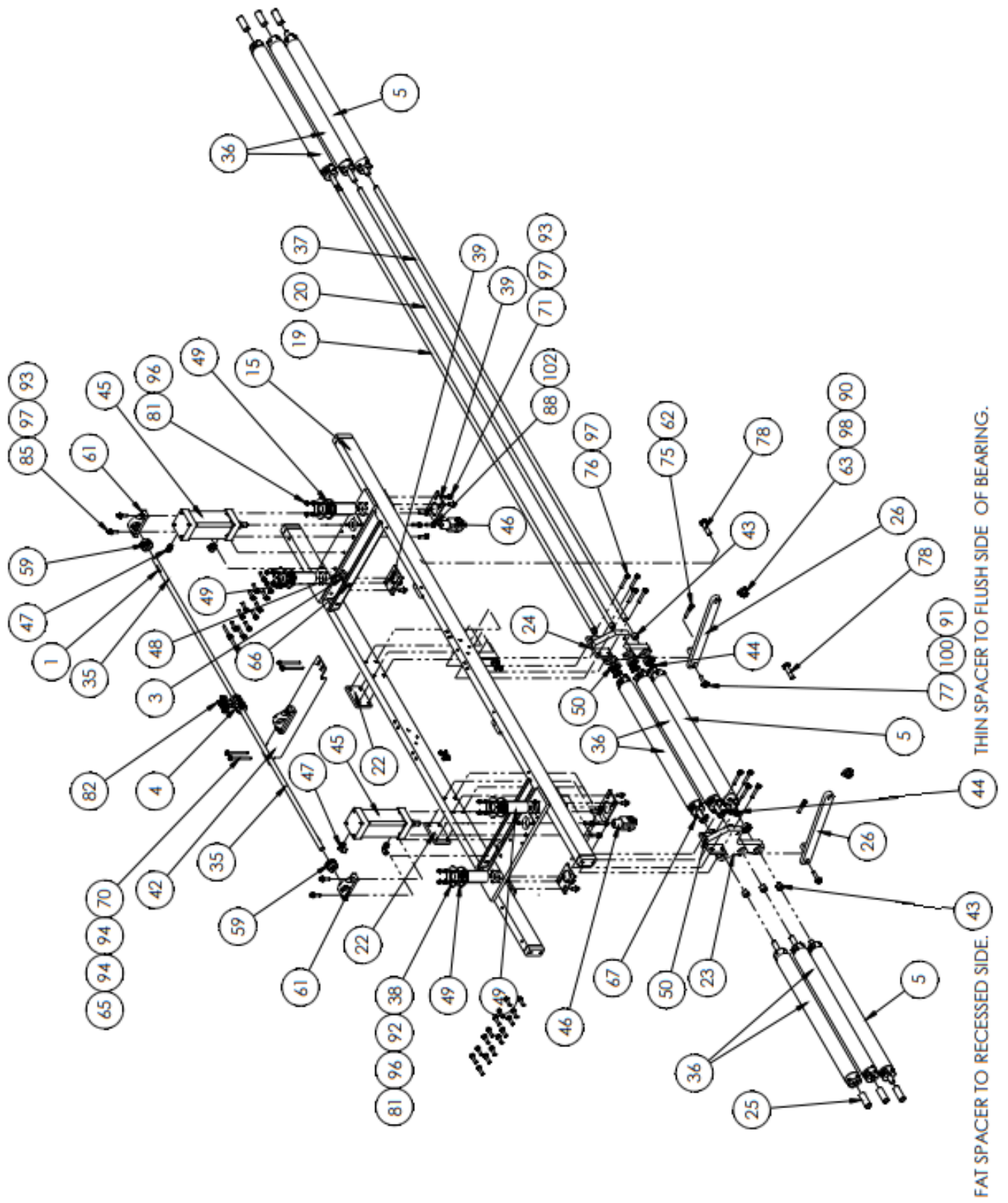

1306229 parts list
continued

ITEM	QTY.	PART NUMBER	DESCRIPTION	ITEM	QTY.	PART NUMBER	DESCRIPTION
52	2	FF3200	STRAIN RELIEF,1/2NPT	78	2	SSHCA1160	5/8-11X2-1/2 HEX CAP
53	2	FF8463	NUT,LOCK, 1/2NPT,NYLON,BLK	79	4	SSHCA5112	1/2-13 X 1-3/4 HHCS, G8
54	2	MM90L4B5	MOTOR,1.5KW,IEC,B5,2HP	80	4	SSHCA5144	1/2-13X2-1/4 HEX CAP
55	1	MMH4015X1	SPROCKET, 1/2 P, 15T	81	16	SSSC01080	1/4-20 X 1-1/4 SOC CAP
56	3	MMH4015X3/4	SPROCKET, 1/2 P, 15T, 3/4 BORE	82	8	SSSC05040	1/4-28 X 5/8, SOC CAP
57	1	MMH4017X1	HT 17 ANSI 40 1" BORE	83	8	SSSC10040	5/16-18 X 5/8 SOC CAP
58	1	MMH4026X1	SPROCKET,#40,26HT,1"B	84	AR	SSSC10064	5/16-18 X 1 SOCKET CAP
59	2	MMNSS12F20-075M	GEAR,SPUR,12P,3/4B W/KEY	85	16	SSSC25088	3/8-16X1-3/8 SOC CAP
60	2	MMRV6330D90	GEARBOX,WORM,RV63.30:1	86	8	SSSCM8X25	SCREW,SOC CAP,M8X25
61	2	MMVPS-112	BEARING,PILLOW BLOCK 3/4B	87	8	SSSCM8X60	M8X60 SOCKET CAP
62	12	NNH3/8-16	NUT,HEX,3/8-16	88	8	SSSCM10X35	CAP SCREW 10MM X 35MM
63	2	NNH5/8-11	NUT,HEX,5/8-11	89	8	WWF3/8	WASHER,FLAT,3/8 OR 10MM
64	4	NNK3/8-16	NUT, KEP, 3/8-16	90	2	WWF5/8	WASHER,FLAT,5/8
65	4	NNK5/16-18	NUT,KEP,5/16-18	91	6	WWFS1/2	WASHER,FLAT,1/2, SAE
66	2	SSAS024160	SHOULDER BOLT 3/8 X 2.5L	92	16	WWFS1/4	WASHER,FLAT,SAE,1/4
67	10	SSBC01024	1/4-20 X 3/8 BUT CAP SC	93	24	WWFS3/8	WASHER,FLAT,SAE,3/8
68	18	SSBC98032	10-32 X 1/2 BUTTON CAP SC	94	8	WWFS5/16	WASHER,FLAT,SAE,5/16
69	8	SSFC98048	#10-32 X .75 SHCSF	95	4	WWL1/2	1/2 LOCK WASHER
70	4	SSHC10256	5/16-18 X 4.0 HEX CAP	96	16	WWL1/4	WASHER,LOCK, 1/4
71	8	SSHC25064	3/8-16 X 1,HEX CAP	97	72	WWL3/8	WASHER,LOCK, 3/8
72	8	SSHC25080	3/8-16X1-1/4 HHCS	98	2	WWL5/8	WASHER,LOCK 5/8
73	28	SSHC25096F	3/8-16 X 1 1/2 HEX HEAD	99	8	WWL5/16	WASHER,LOCK, 5/16
74	4	SSHC25144	3/8-16X2-1/4 HEX CAP SC	100	6	WWL7/16	WASHER,LOCK,7/16
75	4	SSHC25144F	3/8-16X2-1/4 HEX CAP SC	101	18	WWL10	WASHER,LOCK,#10
76	8	SSHC25160	3/8-16X2-1/2 HEX CAP SC	102	8	WWLM10	M10 LOCK WASHER
77	2	SSHC38128	7/16-14 X 2 HEX CAP				

1306308 Carriage, Left Upper Conveyor
AAC Drawing Number 1306308 Rev 3

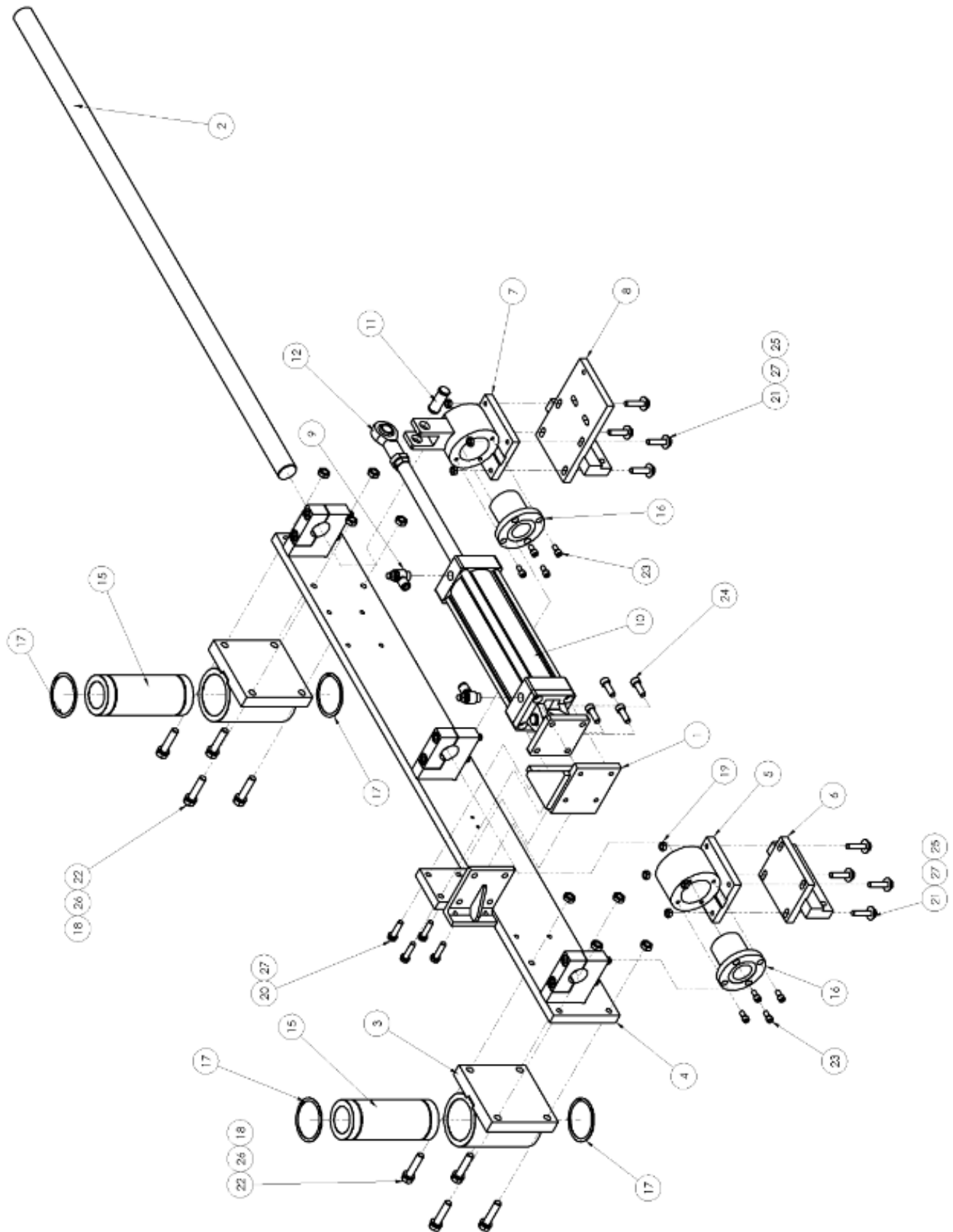

1306308 parts list

ITEM	QTY.	PART NUMBER	DESCRIPTION
1	1	1306312	MOUNT,CYL BRCKT,WLDMNT,R
2	1	1306313	SHAFT, GUIDE RAIL,UPR CONVEYOR
3	2	1306320	MOUNT, BEARING,WELDMNT
4	1	1306323	MOUNT,UPPER MAIN,WLDMNT,L
5	1	1306324	MOUNT,BRING,WELDMNT
6	1	1306328	MOUNT,CONVEYOR,WELDMNT
7	1	1306330	MOUNT,BRING/CYL,WLDMNT
8	1	1306396	MOUNT,CYL/CONVRY,WELDMNT
9	2	AA1983201FU0311	FLOW CONTL 3/8UNIFIT X3/8
10	1	AACSU80X250	CYLINDER,80MM,250S
11	1	AAFCCG2045	PIN,CLEVIS,20MM ODX53MM L
12	1	AAFSGSM20x15	ROD END, FEM-20MM X 1.5MM
13	1	AAFSU80CA	FLANGE,SWIVEL,80MM BORE,S
14	1	AAFSU80CB	FLANGE,SWIVEL,80MM BORE,D
15	2	BBIP32GW	2.0"ID, 3.0"OD, DW LINEAR BALL
16	2	BBULHFR150	BEARING,LINEAR,1.5 B
17	4	MM91665A630	SPRING,RETAINING,EXT,3"
18	8	NNJ1/2-13	NUT,JAM, 1/2-13
19	8	NNJ3/8-16	3/8-16 JAM NUT
20	4	SSH25096	3/8-16 X 1 1/2 HHCS
21	8	SSH25112	3/8-16 X 1-3/4 HEX HEAD
22	8	SSHC45144	1/2-13X2-1/4 HEX CAP
23	8	SSSC10040	5/16-18 X 5/8 SOC CAP
24	4	SSSCM10X30	10M X 30MM, SOC CAP
25	8	WWF3/8	WASHER,FLAT,3/8 OR 10MM
26	8	WWL1/2	1/2 LOCK WASHER
27	12	WWL3/8	WASHER,LOCK, 3/8
28	1	13061264	BRKT, CARRIAGE CYL. EXT

1306334 Carriage, Right Upper Conveyor
AAC Drawing Number 1306334 Rev 2

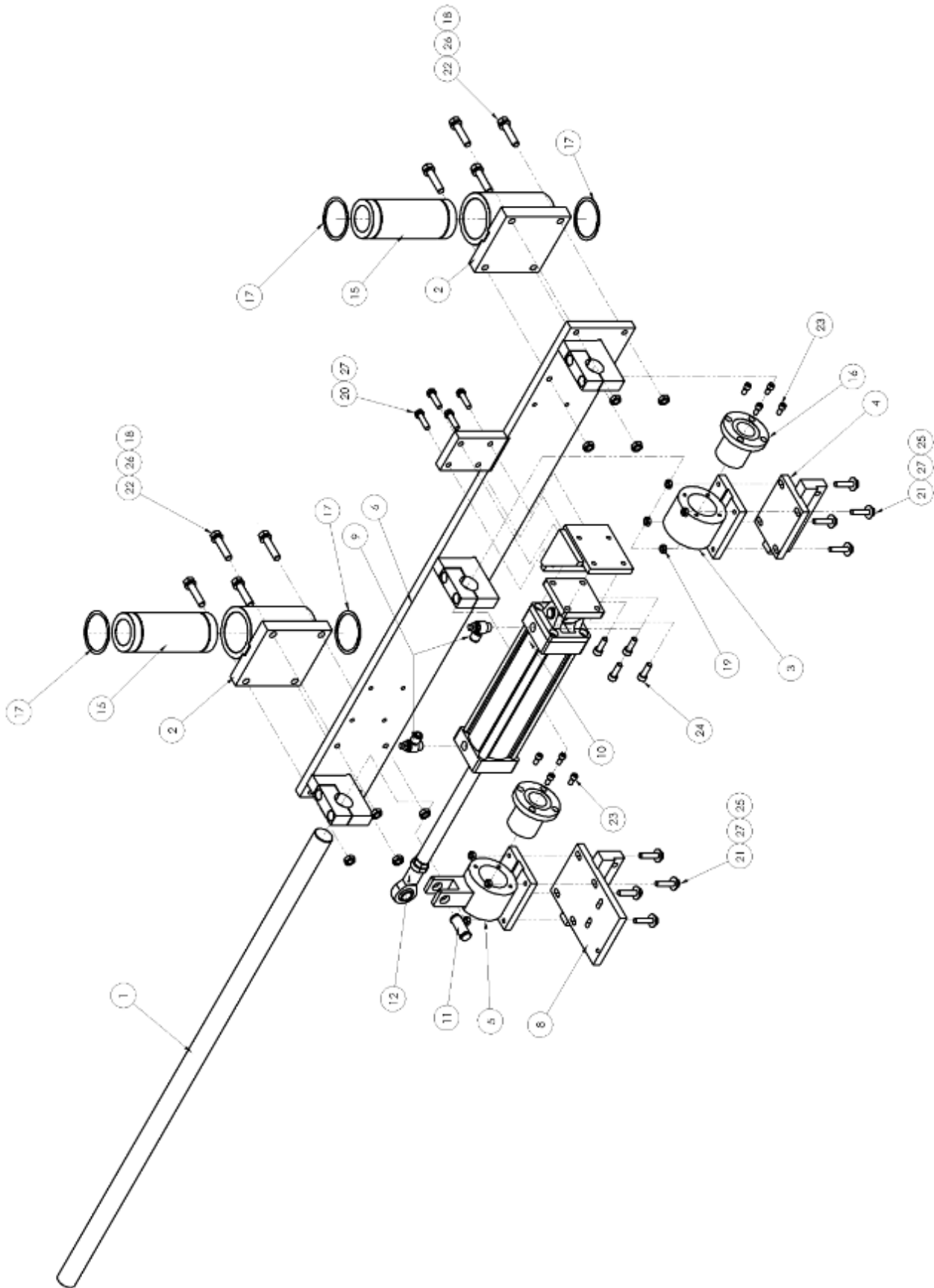

1306334 parts list

ITEM	QTY.	PART NUMBER	DESCRIPTION
1	1	1306313	SHAFT, GUIDE RAIL,UPR CONVEYOR
2	2	1306320	MOUNT, BEARING,WELDMNT
3	1	1306324	MOUNT,BRING,WELDMNT
4	1	1306328	MOUNT,CONVEYOR,WELDMNT
5	1	1306330	MOUNT,BRING/CYL,WLDMNT
6	1	1306332	MOUNT,UPPER MAIN,WLDMNT,R
7	1	1306335	MOUNT,CYL BRCKT,WLDMNT,L
8	1	1306395	MOUNT,CYL/CONVRY,WELDMNT
9	2	AA1983201FU0311	FLOW CONTL 3/8UNIFIT X3/8
10	1	AACSU80X250	CYLINDER,80MM,250S
11	1	AAFCCG2045	PIN,CLEVIS,20MM ODX53MM L
12	1	AAFSGSM20x15	ROD END, FEM-20MM X 1.5MM
13	1	AAFSU80CA	FLANGE,SWIVEL,80MM BORE,S
14	1	AAFSU80CB	FLANGE,SWIVEL,80MM BORE,D
15	2	BBIP32GW	2.0"ID, 3.0"OD, DW LINEAR BALL
16	2	BBULHFR150	BEARING,LINEAR,1.5 B
17	4	MM91665A630	SPRING,RETAINING,EXT,3"
18	8	NNJ1/2-13	NUT,JAM, 1/2-13
19	8	NNJ3/8-16	3/8-16 JAM NUT
20	4	SSHC25096	3/8-16 X 1 1/2 HHCS
21	8	SSHC25112	3/8-16 X 1-3/4 HEX HEAD
22	8	SSHC45144	1/2-13X2-1/4 HEX CAP
23	8	SSSC10040	5/16-18 X 5/8 SOC CAP
24	4	SSSCM10X30	10M X 30MM, SOC CAP
25	8	WWF3/8	WASHER,FLAT,3/8 OR 10MM
26	8	WWL1/2	1/2 LOCK WASHER
27	12	WWL3/8	WASHER,LOCK, 3/8

1306393 Seal Bar Assembly, 86" inch
AAC Drawing Number 1306393 Rev 4

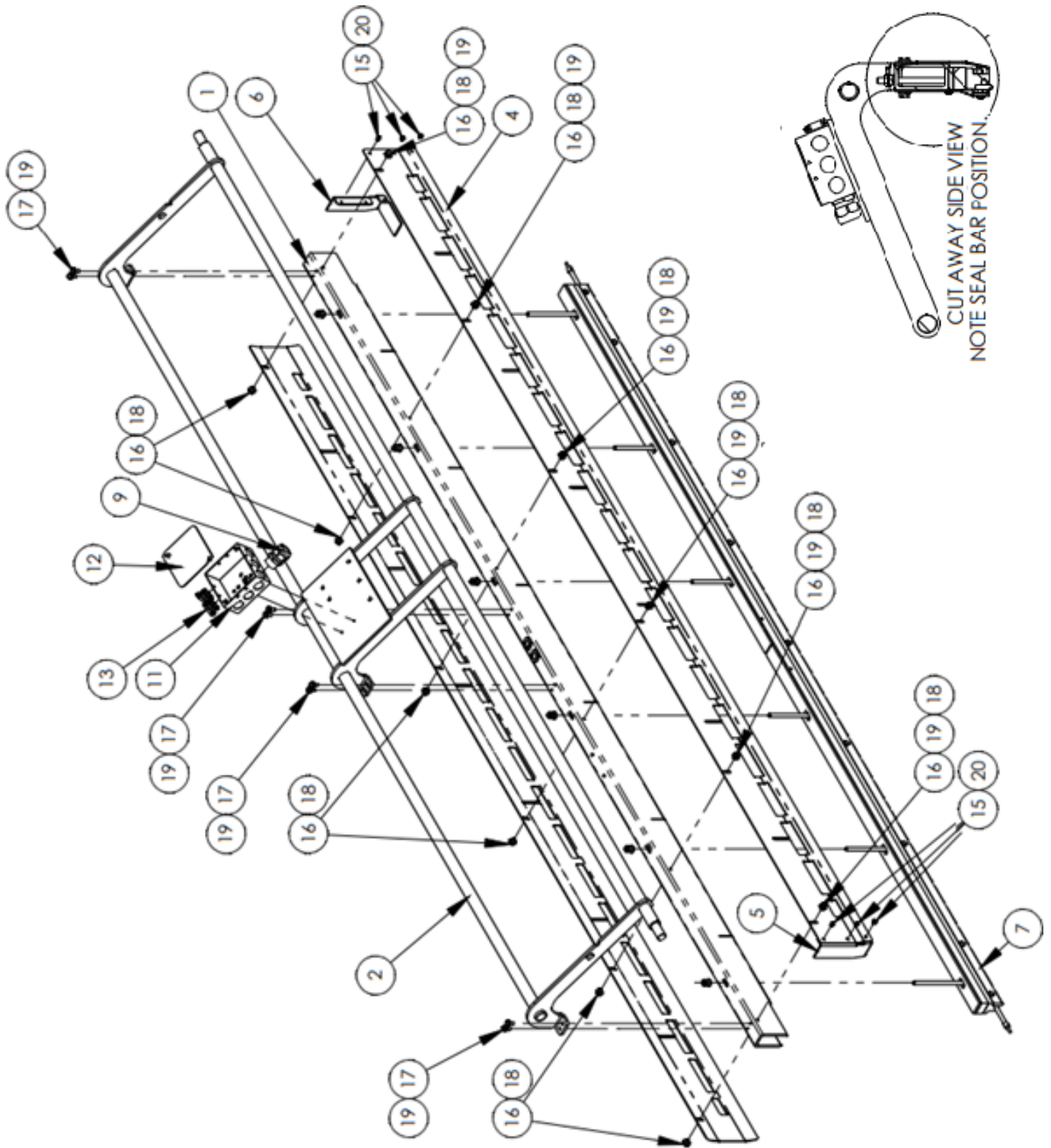

1306393 parts list

ITEM	QTY.	PART NUMBER	DESCRIPTION
1	1	1306394	TUBE, FRONT SEAL
2	1	1306401	SEAL BAR CARRIAGE
3	1	1306405	GUARD,REAR HEAT SEAL
4	1	1306408	GUARD,REAR HEAT SEAL,B
5	1	1306415	GUARD,REAR HEAT SEAL,R
6	1	1306416	GUARD,HEAT SEAL,END,L
7	1	13061474	SEAL BAR ASSEMBLY, 86"
8	*2	FF221-612	SPLICING CONN,LEVERNUT,
9	1	FF3234	STRAIN RELIEF,3/4NPT
10	1	FF8465	NUT,LOCK, 3/4NPT,NYLON,BLK
11	1	K-233	BOX,ELECTRICAL,SQUARE
12	1	K-234	COVER,4IN SQUARE
13	2	K-235	CONNECTOR,ROMEX,1/2"
14	2	MM9307K63	GROMMET,1/2ID,13/16 HOLE
15	6	SSBC90016	8-32 X 1/4 BUTTON CAP
16	12	SSHC01024	1/4-20 X 3/8 HHCS
17	8	SSHC01032	1/4-20 X 1/2 HHCS
18	12	WWFS1/4	WASHER,FLAT,SAE,1/4
19	20	WWL1/4	WASHER,LOCK, 1/4
20	6	WWL8	WASHER,LOCK,#8

13061474 Seal Bar Components

AAC Drawing Number 13061474 Rev 0

ITEM NO.	Default/Qty. are Shown/Qty.	PART NUMBER	DESCRIPTION
1	1	1306203	SEAL BAR ASSEMBLY, 86"
2	2	1306412	SPACER, PTFE
3	2	1306413	THREADED ROD, 6"
4	4	1306414	THREADED ROD, 5"
5	1	EERBN9010S	HEAT ELEMENT, 92"L, 0.315D
6	12	NNH5/16-18	NUT, HEX, 5/16-18
7	6	WWF55/16	WASHER, FLAT, SAE, 5/16

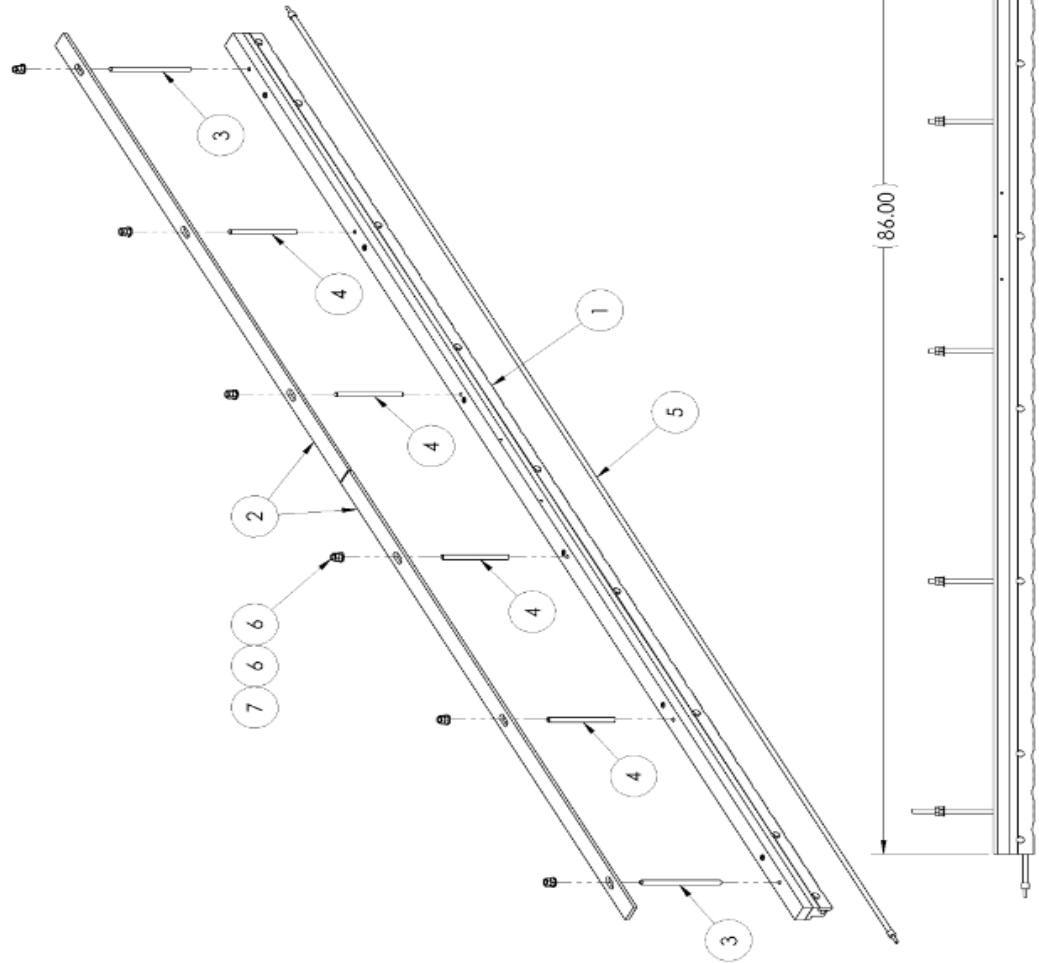

IMPORTANT: TURN THE FIRST NUT UNTIL ALL PARTS MAKE CONTACT BUT DO NOT TIGHTEN. JAM THE SECOND NUT AGAINST IT. THE SEAL BAR MUST BE ABLE TO SLIP DURING THE HEATING PROCESS DUE TO THE DIFFERENCE IN EXPANSION RATES OF ALUMINUM AND STEEL. IF THE ASSEMBLY IS OVERTIGHTENED SEAL BAR WILL BOW, AND CAUSE CUTTING PROBLEMS.

NOTE: TO INSTALL HEATING ELEMENT IT IS NECESSARY TO PARTIALLY DISASSEMBLE THE SEAL BAR ASSEMBLY AS FOLLOWS:

- FIRST: READ THE WARNING NEXT TO ITEM 1 BALLOON!
1. UNSCREW KEP NUTS AND REMOVE THE SPACER.
 2. INSTALL HEAT ELEMENT AND CENTER IT IN THE GROOVE (REF DIM 3.5" EACH END)
 3. INSTALL THE KNIFE BLADE.
 4. REINSTALL THE SPACER.
 5. REINSTALL AND TIGHTEN KEP NUTS.

WARNING!
HANDLE SEAL BAR WITH EXTRA CARE, THE TEFLON COATED PARTS MUST NOT BE SCRATCHED!

1306987 Gear Rack Assembly

AAC Drawing Number 1306987 Rev 0

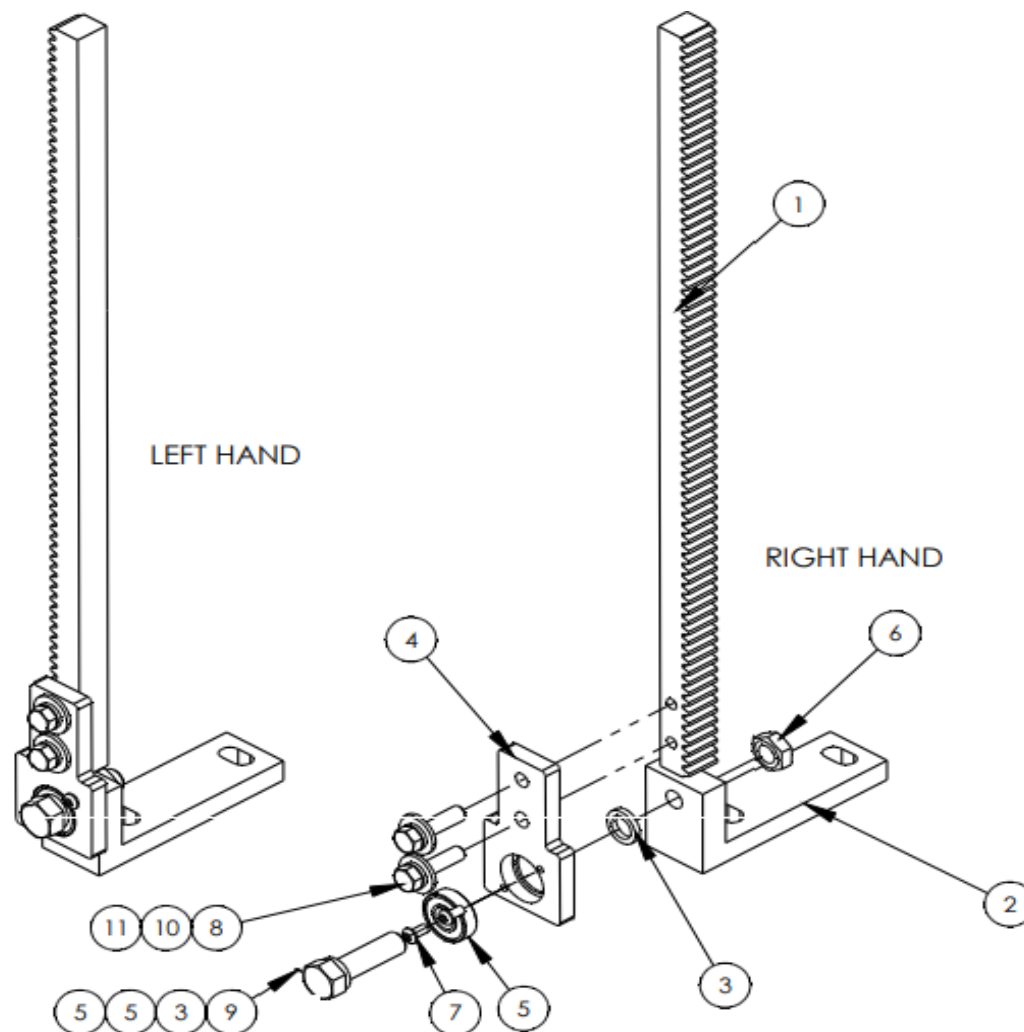

ITEM NO.	Hardware Shown/QTY.	PART NUMBER	DESCRIPTION
1	1	1306305	RACK, GUIDE, UPPER CONV
2	1	1306307	MOUNT, GEAR RACK,
3	2	1306982	SPACER, BEARING MOUNT
4	1	1306983	MOUNT, RACK TO BEARING
5	1	BB1L005	BEARING,BALL,,500D
6	1	NNJ1/2-13	NUT,JAM, 1/2-13
7	2	SSBC98024	10-32 X 3/8 BUTTON CAP SC
8	2	SSHC10080	HEX HEAD, 5/16-18 X 1-1/4
9	1	SSHC45112	1/2-13 X 1-3/4 HHCS, G8
10	2	WWF5/16	WASHER,FLAT,5/16
11	2	WWL5/16	WASHER,LOCK, 5/16

1306377 Lower Conveyor Assembly

AAC Drawing Number 1306377 Rev

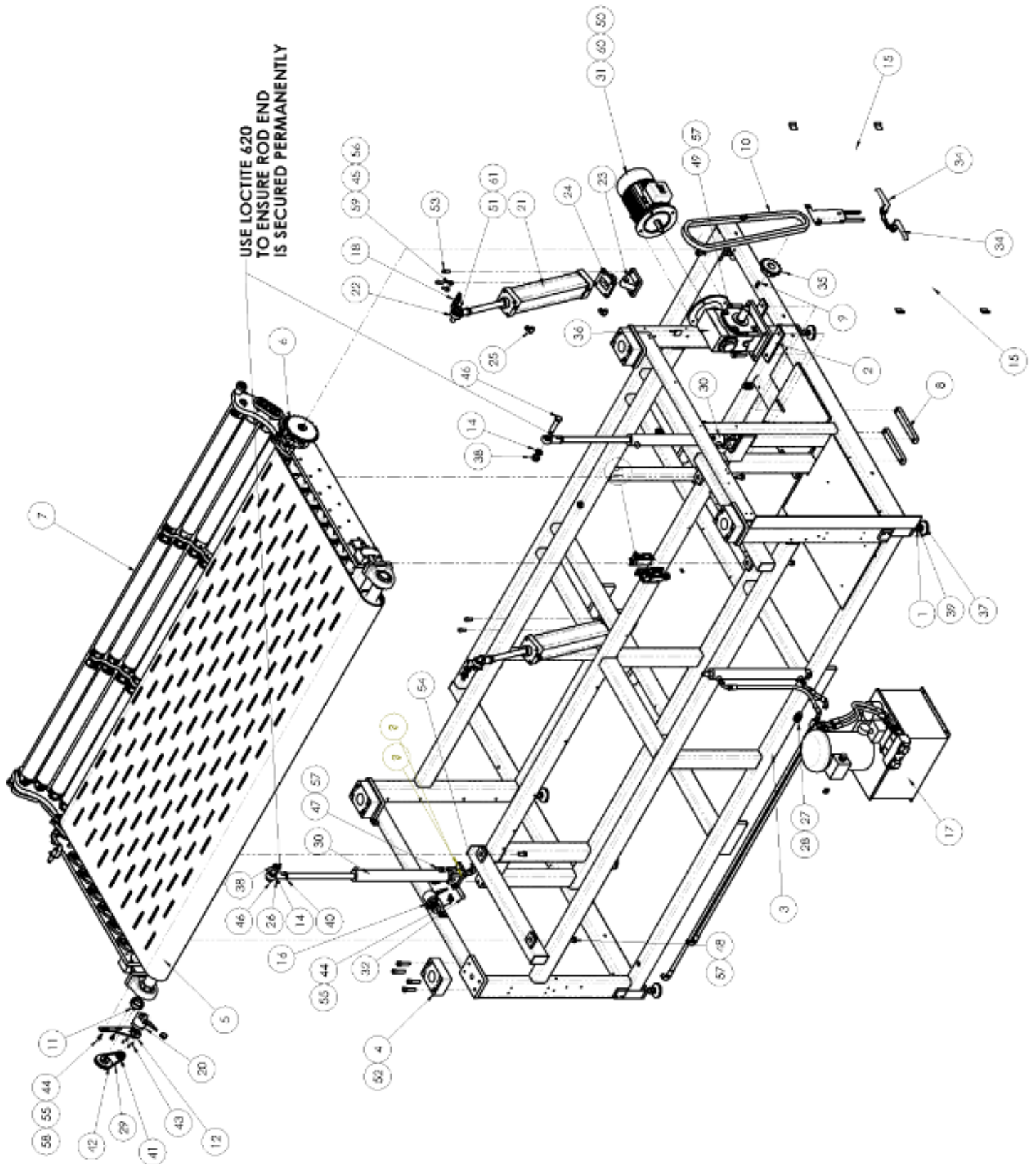

1306377 parts list

ITEM	QTY.	PART NUMBER	DESCRIPTION	ITEM	QTY.	PART NUMBER	DESCRIPTION
1	8	0411-1063	ROD, THREADED, 5/8-11 X 5	33	2	MM98335A074	SPRING CLIP, .120 D
2	2	1306006	SPACER, GEARBOX, MAIN	34	2	MMELH149	LATCH HANDLE
3	1	1306049	FRAME, LOWER MAIN	35	1	MMH6015X138	#60 GEAR 15HT 1.375ID BORE
4	4	1306068	RAIL GUIDE, MAIN FRM	36	1	MMIC8030D90	GEARBOX, WORM, RV80, 30:1
5	1	1306343	CONVEYOR, LOWER	37	8	MMML-2	LEVELING PAD, 5/8-11
6	1	1306367	CHAIN, DRIVE, REAR ROLLER	38	2	NNH3/4-16	NUT, HEX, 3/4-16 ZINC PLATED
7	1	1306369	UPTURN ROLLER ASBLY	39	16	NNH5/8-11	NUT, HEX, 5/8-11
8	2	1306381	MOUNT, PLATE, MAIN DRIVE	40	2	NNJ3/4-16	3/4-10 JAM NUT
9	1	1306383	5/16 X 5/16 X 1.2 KEY	41	1	PP24XLB37M1	PULLEY, GEAR, 1/5 PITCH
10	1	1306384	CHAIN, ROLLER, MAIN L DRIVE	42	1	PP48AXL037M2	PULLEY, GEAR, 1/5P, 48T 3/8B
11	1	1306385	MOUNT, GEAR, SHAFT END	43	4	SSF3CM3X10	M3-0.50X10, SCEW FLAT ALL
12	1	1306387	BRACKET, MOUNT, ENCODER	44	4	SSHCO1064	1/4-20 X 1 HHCS
13	2	1306424	MOUNT, LOWER HYD CYL	45	4	SSHC25064	3/8-16 X 1, HEX CAP
14	2	1306427	SPACER, MOUNT, CYLINDER	46	2	SSHC33176	3/4-16 X 2-3/4 HEX CAP
15	2	1306447	DOOR, FRAME, LOWER, R	47	4	SSHC45064	1/2-13X1 HEX CAP
16	1	1306601	POSITIONING ENCODER ASSY	48	4	SSHC45080	1/2-13X1-1/4 HEX CAP
17	1	1306614	HYD, POWER PACKAGE	49	4	SSHC45160	1/2-13X2-1/2 HEX CAP
18	2	1306936	MOUNT, CYLINDER, MOVABLE	50	4	SSHCM10X25	SCR, HEX CAP, M10X25
19	1	13901096	SAFETY SWITCH SUB ASSY	51	2	SSHCM20X65	SCREW, HEX CAP M20X2.5x65,
20	1	1953-405A	ENCODER, W/PLUG, 1953, 1306	52	16	SSSC45128	SCREW, SOC CAP, 1/2-13 X 2"
21	2	AACSU80X400	CYLINDER, 80MMB, 400S	53	4	SSSCM10X25	10M X 25MM, SOC CAP
22	2	AAFSGM20X15	ROD END, FEM-20MM X 1.5MM	54	2	WWF5/8	WASHER, FLAT, 5/8
23	2	AAFSU80CA	FLANGE, SWIVEL, 80MM BORE, S	55	4	WWF51/4	WASHER, FLAT, SAE, 1/4
24	2	AAFSU80CB	FLANGE, SWIVEL, 80MM BORE, D	56	4	WWF53/8	WASHER, FLAT, SAE, 3/8
25	4	AAQME-3-3	MALE ELBOW 3/8 OD TUBE	57	12	WWL1/2	1/2 LOCK WASHER
26	2	BBAW-9	ROD END, 3/4-16, 3/4 B	58	4	WWL1/4	WASHER, LOCK, 1/4
27	2	FF3200	STRAIN RELIEF, 1/2NPT	59	4	WWL3/8	WASHER, LOCK, 3/8
28	2	FF8463	NUT, LOCK, 1/2NPT, NYLON, BLK	60	4	WWLM10	M10 LOCK WASHER
29	1	GG170XL037	BELT, GEAR, 1/5P, 3/8W, 85T	61	2	WWLM20	M8 LOCK WASHER
30	*REF	HC251510PP14	CYL, HYD, 1.5"B, 1.0"R, 14"S	62	1	13061508	IDLER SPROCKET
31	1	MM90L4B5	MOTOR, 1.5KW, IEC, B5, 2HP	63	1	13061507	IDLER SPROCKET STUD
32	2	MM97245A555C	CLEVIS PIN 2.75L, 2.5156 UL, .5 D	64	1	NNJ1/2-13	NUT, JAM, 1/2-13

1306343 Conveyor, Lower

AAC Drawing Number 1306343 Rev 6

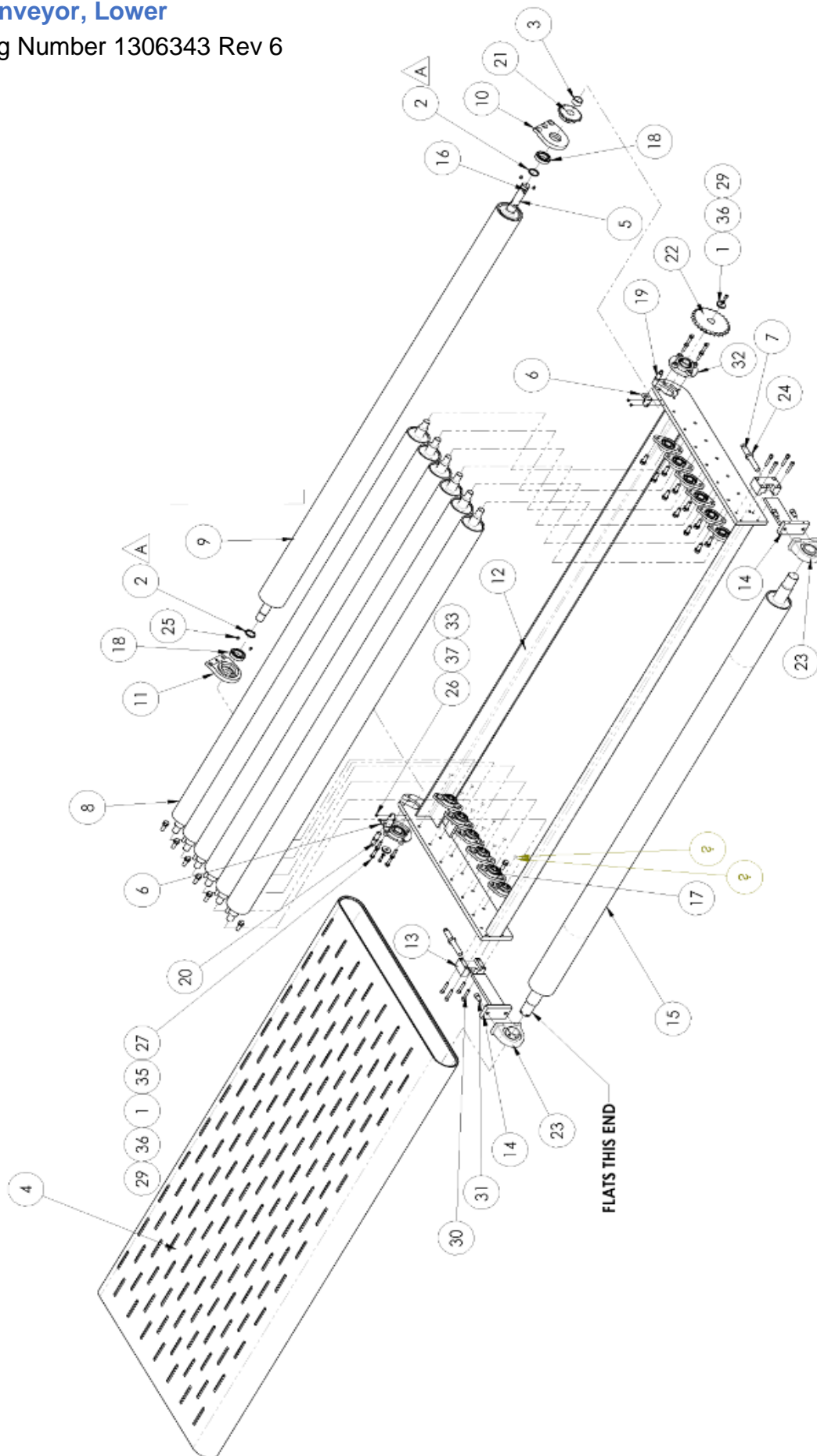

1306343 parts list

ITEM	QTY.	PART NUMBER	DESCRIPTION	ITEM	QTY.	PART NUMBER	DESCRIPTION
1	2	1306005	RETAINER,SHAFT,GEARBOX	20	1	FFS18SN6RQ	EYE,OPPOSED,RCVR,NPN,IR
2	2	13061390	ROLLER SPACER	21	1	MMH4024X1-1/4	SPROCKET,#40,24T,1.25B
3	1	1306159	SPACER, SPROCKET	22	1	MMH6026X1-1/4	SPROCKET,#60,26T,1.25B
4	1	1306199	BELT, CONVEYOR, LOWER	23	2	MMUCPA209-28	BEARING,PILLOW BLOCK,1.25
5	1	1306241	KEY, 1/4 X 1/4 X .75	24	2	NNJ3/4-10	3/4-10 JAM NUT
6	2	1306257	BRKT, MTG, FFS18S/E,EXT	25	4	SSBC01024	1/4-20 X 3/8 BUT CAP SC
7	2	1306317	SCREW, BELT TENSION	26	4	SSBC90024	8-32X3/8 BUTTON CAP
8	6	1306339	ROLLER, SUPPORT, BELT	27	8	SSHC25096	3/8-16 X 1 1/2 HHCS
9	1	1306345	ROLLER, DRIVE, LOWER	28	24	SSHC45096	1/2-13X1-1/2 HEX CAP
10	1	1306348	BEARING SUPPORT,RT FT	29	2	SSSC10048	5/16-18X3/4 SOC CAP
11	1	1306351	BEARING SUPPORT, LT FT	30	8	SSSC25128	3/8-16X2" SOC CAP
12	1	1306352	FRAME, CONVEYOR, LOWER	31	4	SSSC45064	SCREW,SOC CAP,1/2-13 X 1"
13	2	1306353	BLOCK, BELT TENSION	32	2	UUCFC206-20	BEARING,FLANGE,1.25B,4 BOLT
14	2	1306356	MOUNT, BEARING	33	4	WWF8	WASHER, FLAT, #8
15	1	1306357	ROLLER, DRIVEN, LOWER	34	24	WWL1/2	1/2 LOCK WASHER
16	1	1306380	KEY, 1/4 X 1/4 X 1.20	35	9	WWL3/8	WASHER,LOCK, 3/8
17	12	1306475	BEARING,FLANGE,1",2 BOLT	36	2	WWL5/16	WASHER,LOCK, 5/16
18	2	BBR22	BEARING,BALL,1.375B,2.5OD	37	4	WWL8	WASHER,LOCK,#8
19	1	FFS186EQ	EYE,OPPOSED,XMIT,IR LED,				

1306369 parts list

ITEM	QTY.	PART NUMBER	DESCRIPTION	ITEM	QTY.	PART NUMBER	DESCRIPTION
1	7	1306005	RETAINER,SHAFT,GEARBOX	19	18	BB2281288	BEARING,BALL,,75 ID
2	7	1306244	KEY, 3/16 X.75 LG	20	48*	MM130-10A	TAPE,P/TFE,1.5 WIDE
3	1	1306349	BEARING SUPPORT, LT REAR	21	1	MMH4013X3/4	SPROCKET,#40,13T,3/4"B
4	1	1306365	BEARING SUPPORT, RT REAR	22	6	MMH4014X3/4	SPROCKET,#40,14T,3/4"B
5	1	1306366	CENTER SUPPORT FRAME	23	24	SSBC01024	1/4-20 X 3/8 BUT CAP SC
6	3	1306368	CHAIN, #40 X 13" LONG	24	6	SSFC01048	1/4-20 X 3/4 FLAT CAP
7	3	1306370	SHAFT,UP ROLLER, DBL KEY	25	6	SSFC45064	1/2-13 X 1 SOC FLAT CAP
8	1	1306371	SHAFT,UP ROLLER,SGL KEY	26	6	SSHC10040	5/16-18 X 5/8 HHCS
9	8	1306372	SPACER,,75 IDX1.0X.56L	27	2	SSHC34176	3/4-10 X 2-3/4 HEX CAP
10	2	1306379	SPACER, BEARING SUPPORT	28	4	SSHC45096	1/2-13X1-1/2 HEX CAP
11	12	1306392	TURNING ROLLER, RUBBER	29	12	SSHC8X25	SCREW,HEX CAP M8X25
12	3	1306617	MOUNT,FINGER,EJECTOR	30	7	SSSC10048	5/16-18X3/4 SOC CAP
13	3	1306618	PLATE,PUSH FINGER	31	3	SSSM10X30	SCREW, SOCKET SET M1OX1.5 X 30MM
14	3	1306619	MOUNT,CYLINDER,UP ROLLERS	32	12	WWFM8	WASHER, FLAT, M8 I.D.
15	8	1307343	SPACER,,75 IDX1.0X.15L	33	4	WWL1/2	1/2 LOCK WASHER
16	8	1307344	SPACER,,75 IDX1.0X.34L	34	13	WWL5/16	WASHER,LOCK, 5/16
17	3	AACSDA50X100	COMPACT,CYLINDER,50MM B	35	12	WWLM8	M8 LOCK WASHER
18	6	AAQME-3-4U	MALE ELBOW,3/8OD TUBE 1/4				

1306601 Positioning Encoder Assembly

AAC Drawing Number 1306601 Rev 2

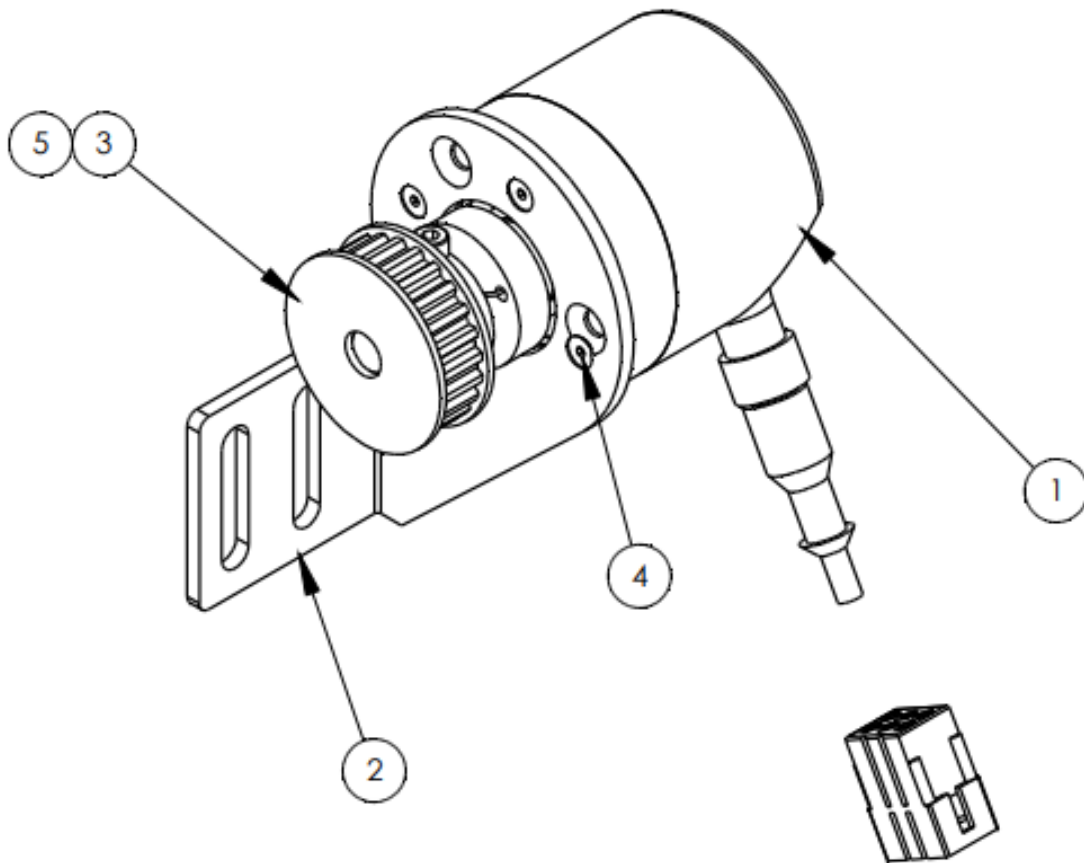

ITEM NO.	Hardware Shown/QTY.	PART NUMBER	DESCRIPTION
1	1	1953-405A	ENCODER, W/PLUG, 1953, 1306
2	1	1306598	BRACKET,ENCODER MOUNT
3	1	PP24XLB37M1	PULLEY, GEAR,1/5 PITCH
4	4	SSFCM3X10	M3-0.50X10, SCEW FLAT ALL
5	2	SSSCM4X10	SCREW,SOC CAP,M4-0.7X8

1306614 Hydraulic Power Package

AAC Drawing Number 1306614 Rev 3

1. BLEED LINES AND CYLINDERS TO ENSURE NO AIR IS TRAPPED IN THE HYDRAULIC LINES.
2. ATTACH CYLINDERS TO MACHINE USING TOUCH SCREEN TO MOVE THE CYLINDER INTO POSITION.
3. CHECK TOUCH SCREEN CONTROLS TO ENSURE CYLINDERS ARE EXTENDING WHEN THE "PLATFORM ASCEND" BUTTON IS PRESSED.
4. ADJUST FLOW CONTROLS TO MATCH ASCEND SPEED WITH THE DESCEND SPEED.

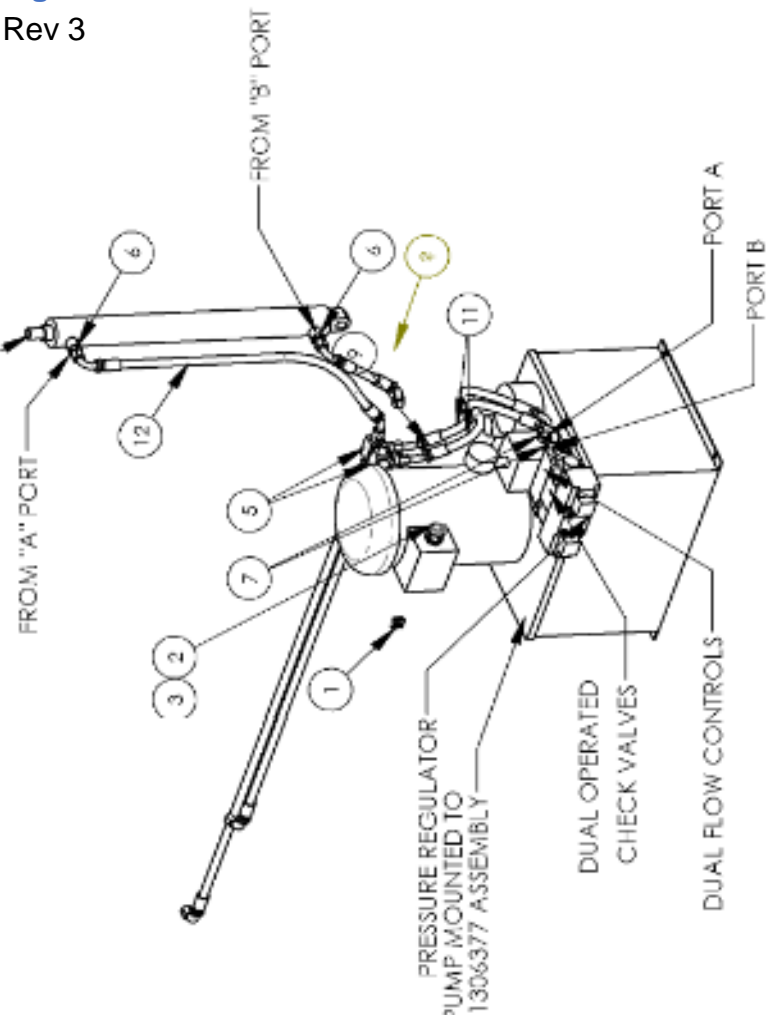

ITEM	QTY.	PART NUMBER	DESCRIPTION
1	1	FF221-413	3 POS CONNECTOR, LEVERNUT
2	1	FF3200	STRAIN RELIEF, 1/2NPT
3	1	FF8463	NUT, LOCK, 1/2NPT, NYLON, BLK
4	2	HC251510PP14	CYL, HYD, 1.5" B, 1.0" R, 14" S
5	2	HF03310606	TEE, 9/16-18 M-JIC, #6
6	4	HF20270266S	FITTING, HYD, STR, O-RING
7	2	HF64000608	FITTING, HYD, STR, O-RING
8	1	HH42246690105	HYD HOSE, 105", 6X6X90X1/4
9	1	HH42246690123	HYD HOSE, 123", 6X6X90X1/4
10	1	HH42246690458	HYD HOSE, 9", 6X6X45X90X1/4
11	2	HH422466904519	HYD HOSE, 19.83", 6X6X45X90X1/4
12	1	HH422466904526	HYD HOSE, 27.02", 6X6X45X90X1/4
13	1	HYMG2A	HYD PUMP, 2 GAL/MIN, 2 HP, 3 PH

13901096 Safety Switch Assembly

AAC Drawing Number 13901096 Rev 0

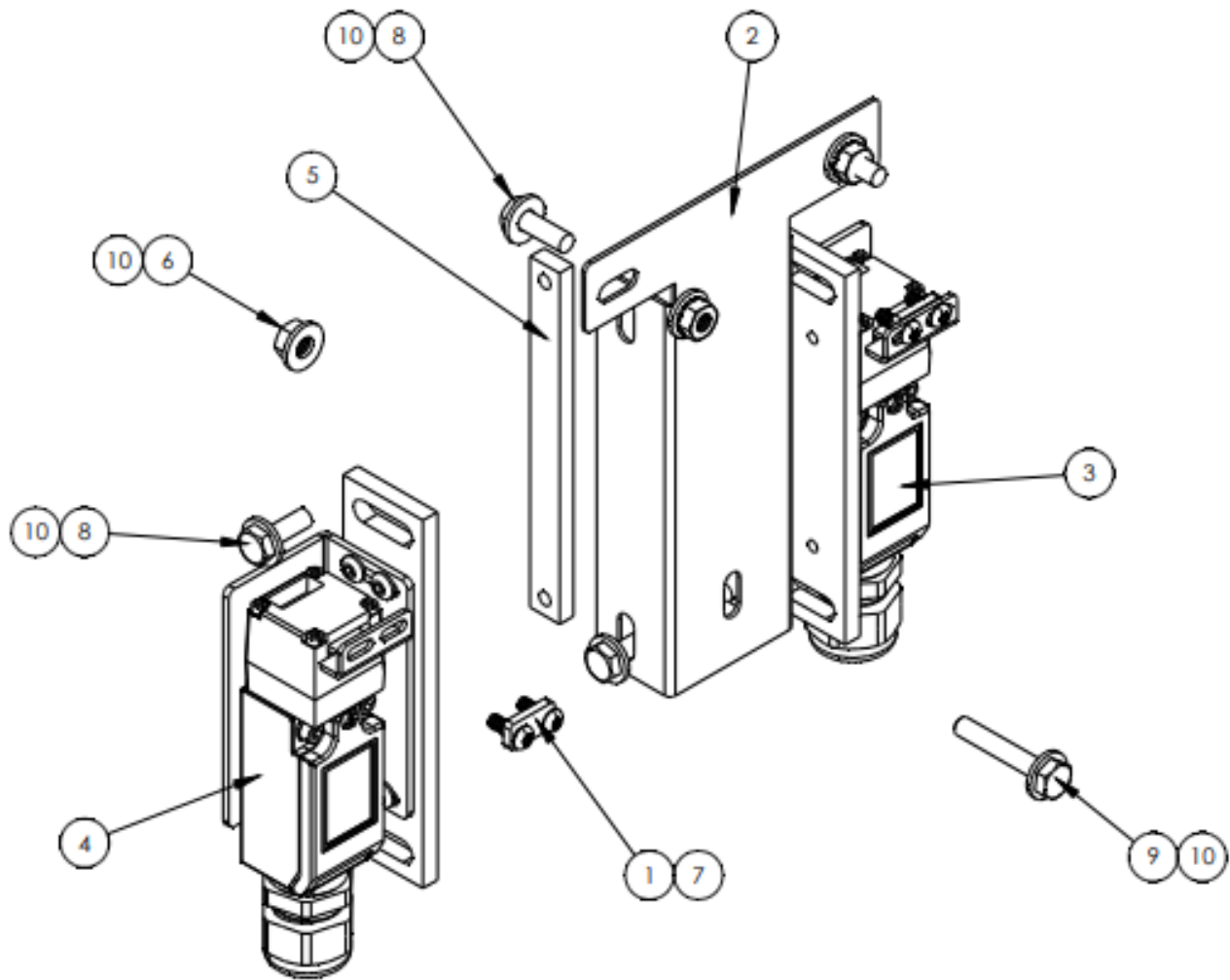

ITEM NO.	QTY.	PART NUMBER	DESCRIPTION
1	2	1060008	PLATE,NUT,8-32X.50
2	1	13901067	DUAL SENSOR BRACKET, LOWER
3	1	13901091	SAFETY INTERLOCK SWITCH ASSY
4	1	13901091	SAFETY INTERLOCK SWITCH ASSY
5	2	13901094	PLATE, NUT, 1/4-20@4.67 CTC
6	3	NNK1/4-20	NUT,KEP,1/4-20
7	4	SSBC90032	8-32X1/2 BUTTON CAP
8	6	SSHCO1048	1/4-20 X 3/4 HEX CAP
9	1	SSHCO1096	1/4-20 X 1-1/2 HHCS
10	10	WWFS1/4	WASHER,FLAT,SAE,1/4

1306805 Roller, Pinch Assembly
 AAC Drawing Number 1306805 Rev 4

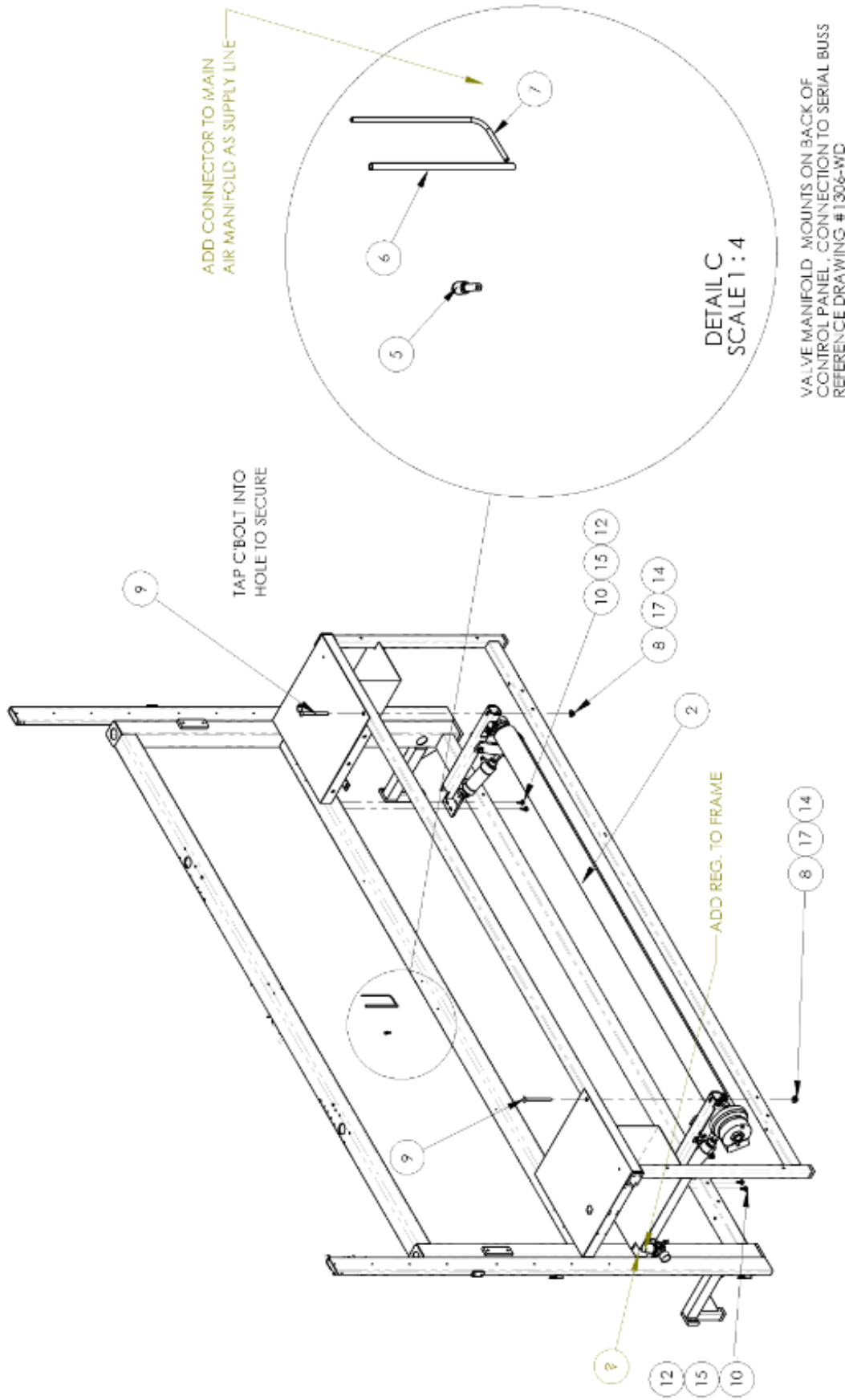

VALVE MANIFOLD MOUNTS ON BACK OF CONTROL PANEL. CONNECTION TO SERIAL BUSS REFERENCE DRAWING #1306-WD

1306805 parts list

ITEM	QTY	PART NUMBER	DESCRIPTION
1	1	1306681-PD	DIAGRAM,PNEUMATIC,1306
2	1	1306686	ROLLER, PINCH ASSY UNDER
3	2	1391160	CABLE ASSY, VALVE, DIN, 3M
4	1	AA198-503B	REG, 0-30 W/GAUGE & BRKT, R
5	1	AAQPR-5-4	REDUCER, 1/4-5/32 QUICK
6	1	AATP4-1	1/4" OD POLYURETHANE
7	1	AATP5/32	5/32" OD POLYURETHANE
8	2	NNH3/8-16	NUT, HEX, 3/8-16
9	2	SSBK25320	3/8-16X5, CARR. BOLT
10	4	SSHC01064	1/4-20 X 1 HHCS
11	2	SSPP98032	10-32 X 1/2 PAN PHIL
12	4	WWF1/4	WASHER, FLAT, 1/4", COM
13	2	WWF10	WASHER, FLAT, #10, COM
14	2	WWF3/8	WASHER, FLAT, 3/8 OR 10MM
15	4	WWL1/4	WASHER, LOCK, 1/4
16	2	WWL10	WASHER, LOCK, #10
17	2	WWL3/8	WASHER, LOCK, 3/8

1306686 Roller, Pinch Assembly

AAC Drawing Number 1306686 Rev 1

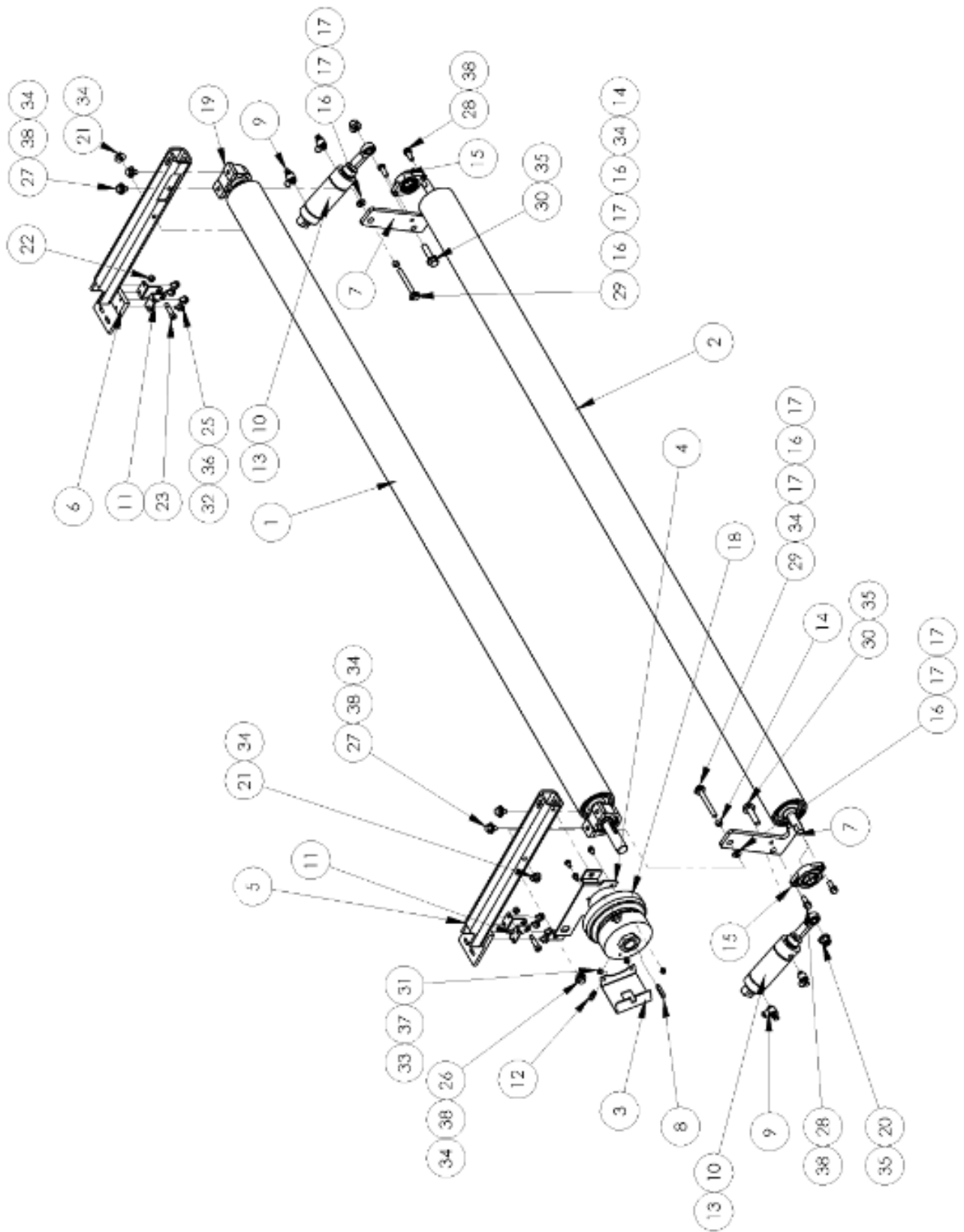

1306686 parts list

ITEM	QTY	PART NUMBER	DESCRIPTION	ITEM	QTY	PART NUMBER	DESCRIPTION
1	1	1306697	ROLLER ASSY, LOADING UPR	20	2	NNE1/2-13	NUT,NYLOCK,1/2-13
2	1	1306699	ROLLER ASSY, IDLER	21	2	NNE3/8-16	NUT, ELASTIC 3/8-16
3	1	1306715	MOUNT, CLUTCH BACK PRES	22	2	NNE5/16-18	NUT,ELASTIC LOCK,5/16-18
4	1	1306718	MOUNT, CLUTCH BRAKE	23	2	SSAS024064	SHULDER BOLT 3/8 X .1.00L
5	1	1306732	MOUNT, LEFT SIDE	24	3	SSHC01032	1/4-20 X 1/2 HHCS
6	1	1306734	MOUNT, RIGHT SIDE	25	8	SSHC01040	1/4-20 X 5/8 HHCS
7	2	1306746	HINGE BLOCK	26	2	SSHC25040	3/8-16X5/8,HEX CAP
8	1	1397574	KEY, 1/4 X 1/4 X 1.5L	27	4	SSHC25048	3/8-16X3/4,HEX CAP
9	4	AA198RA404U	FLOW CONTROL,1/4PTX1/4	28	4	SSHC25064	3/8-16 X 1,HEX CAP
10	2	AAC312DXP	AIR CYLINDER 2" B X 2" S	29	2	SSHC25224	3/8-16 X 3.5 HEX CAP
11	2	AAFD-229	BRKT, PIVOT, 3/8 BORE	30	2	SSHC45128	1/2-13 X 2,HEX CAP
12	1	AAQMC-5-8	QU. MALE CONN 5/32X1/8	31	3	SSHC95024	SCREW, HEX CAP
13	2	BBAW-8Z	BEARING,ROD END,FEMALE	32	8	WWF1/4	WASHER, FLAT, 1/4", COM
14	2	BBB-66	BEARING,NEEDLE,.375B	33	4	WWFS10	WASHER, FLAT, #10, SAE
15	2	BBFHSLF204-12G	BEARING, FLANGE, 3/4" ID	34	10	WWF3/8	WASHER,FLAT,3/8 OR 10MM
16	4	BBNTA613	BEARING,THRUST,375BORE	35	4	WWFS1/2	WASHER,FLAT,1/2, SAE
17	8	BBTRA613	WASHER,THRUST,STL, .375B	36	11	WWL1/4	WASHER,LOCK, 1/4
18	1	MM805275	CLUTCH,AIR,1.0 B,370 IN-L	37	3	WWL10	WASHER,LOCK,#10
19	2	MMUCPA205-16	PILLOWBLOCK,TAPPED BASE	38	10	WWL3/8	WASHER,LOCK, 3/8

13061310 Off-Load Pusher, Roller

AAC Drawing Number 13061310 Rev 1

Sheet 1: Bill of Materials

ITEM	QTY	PART #	DESCRIPTION
1	2	1306017	RETAINER, GUIDE BAR
2	2	1306019	GUIDE, RAIL, OFFLOAD
3	2	13061057	TROUGH, LIMIT SWITCH SENSOR MTG BRKT
4	1	13061220	OFFLOAD PUSHER, MOTOR ASSY
5	1	13061320	FRAME, WELDMENT, ROLLER TYPE
6	1	13061325	PUSHER, PADDLE ASSEMBLY
7	3	13061326	PANEL, COVER PANEL,
8	1	13061329	EJECTOR ARM MOUNT ASSEMBLY
9	1	13061333	COVER MOTOR DIRVE
10	1	13061346	DRIVE CHAIN, EJECTOR
11	1	13061351	SPROCKET ASSEM, INSIDE MNT
12	1	13061354	UNLOAD RAMP PLATE
13	1	13061462	COVER MOTOR DIRVE
14	1	1306183	BRKT, MTG, FFS18S/E
15	1	1306196	MOUNT, SENSOR BRACKET
16	2	1307374	PLATE, NUT, 8-32 X 22MM CTC X 10 GA
17	2	FFGLA01A1B	SWITCH, LIMIT, ROLLER
18	2	FFM4518	STRAIN RELIEF, LIQ TIGHT
19	1	FFT18FF100Q	EYE, FIXED FIELD, 4IN
20	28	MM2277T35	ROLLER, 1.9"DIA, 12 LNG
21	4	MM6436K23	COLLAR, SPLIT, 1-.5ID, 2PC
22	1	MM9600K21	GROMMET, RUBBER, 9/16 ID
23	2	NNE10-32	NUT, ELASTIC LOCK
24	8	NNH5/16-18	NUT, HEX, 5/16-18
25	8	NNK5/16-18	NUT, KEP, 5/16-18
26	4	SSBC90024	8-32X3/8 BUTION CAP
27	24	SSBC98040	10-32 X 5/8 BUTION CAP SC
28	8	SSBK10096	BOLT, CARRAGE, 5/16X1.5
29	2	SSFC98048	#10-32 X .75 SHCSF
30	8	SSHC10096	5/16-18 X 1-1/2 HHCS

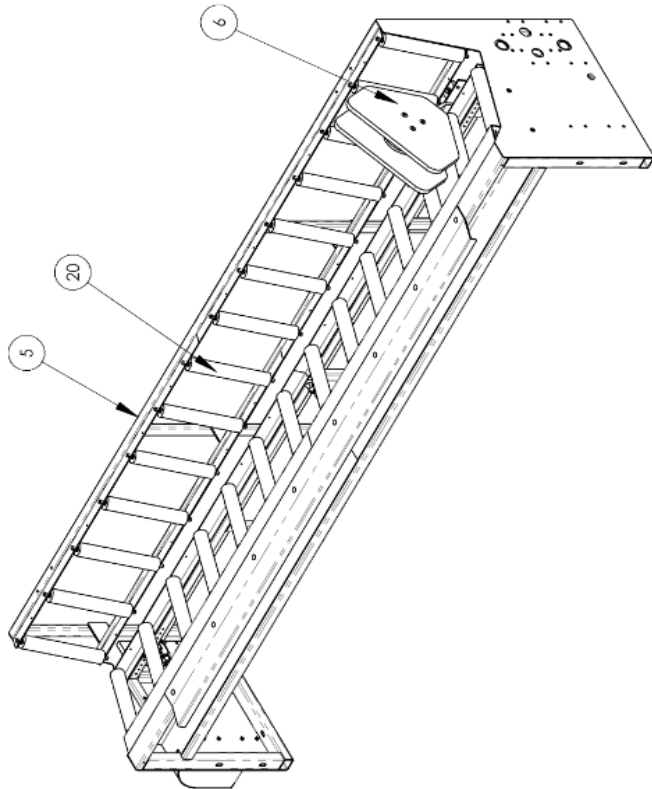

ITEM	QTY	PART #	DESCRIPTION
31	4	SSHC10288	5/16-18 X 5 HEX CAP SC
32	4	SSHC10352	5/16-18 X 5-1/2 HCSC
33	8	SSSC01040	1/4-20 X 5/8" SOC CAP SC
34	4	SSSC05040	1/4-28 X 5/8, SOC CAP
35	4	SSSC25112	3/8-16X1-3/4 SOC CAP
36	5	SSSC90080	#8-32 X 1-1/4 SOC CAP SC
37	16	WWF5/16	WASHER, FLAT, 5/16
38	8	WWF8	WASHER, FLAT, #8
39	12	WWF5/14	WASHER, FLAT, SAE, 1/4
40	26	WWF5/10	WASHER, FLAT, #10, SAE
41	8	WWF5/16	WASHER, FLAT, SAE, 5/16
42	12	WWL1/4	WASHER, LOCK, 1/4
43	24	WWL10	WASHER, LOCK, #10
44	17	WWL5/16	WASHER, LOCK, 5/16
45	4	WWL8	WASHER, LOCK, #8

Sheet 2: Drive Train

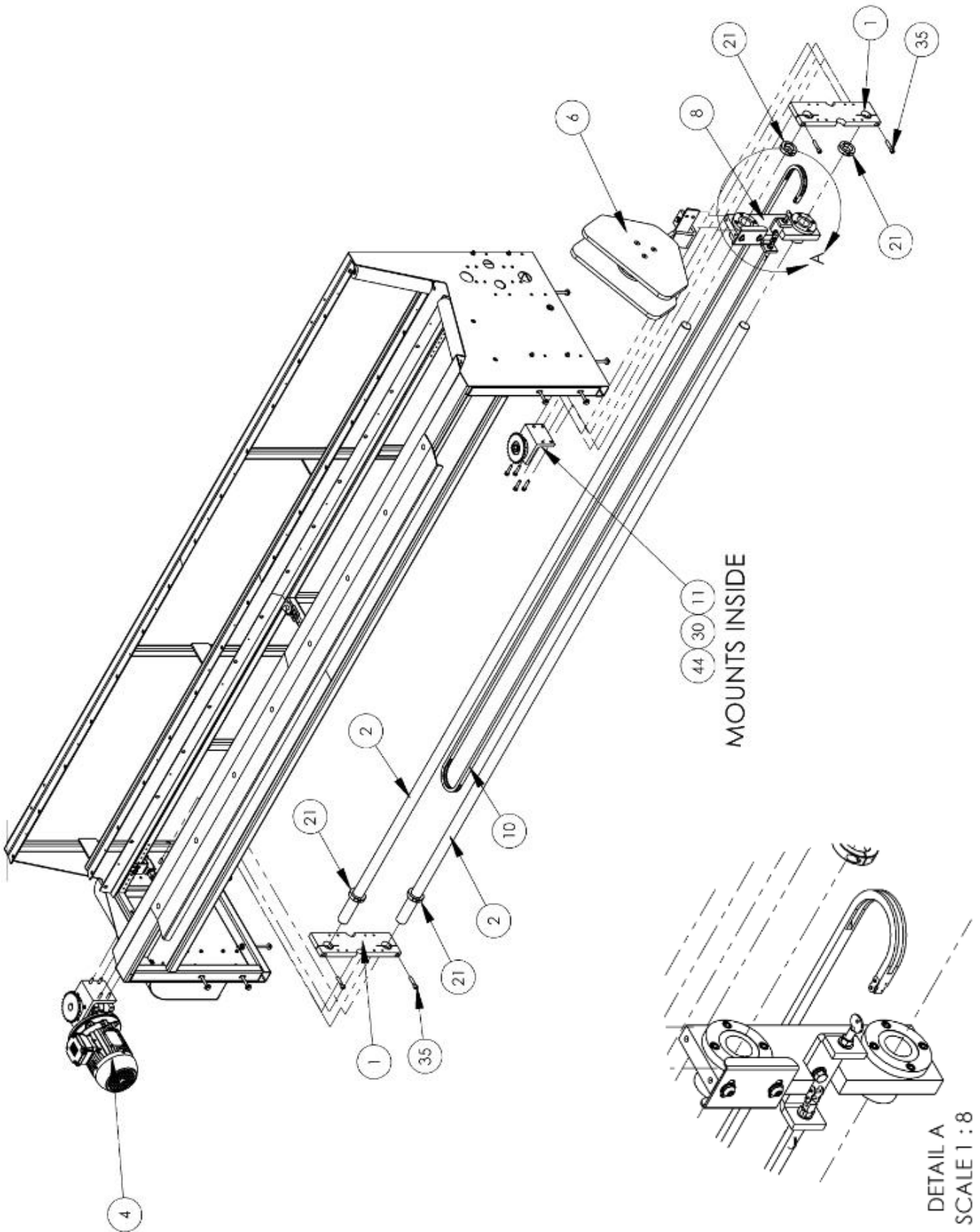

DETAIL A
SCALE 1 : 8

Sheet 3: Sensors and Switches

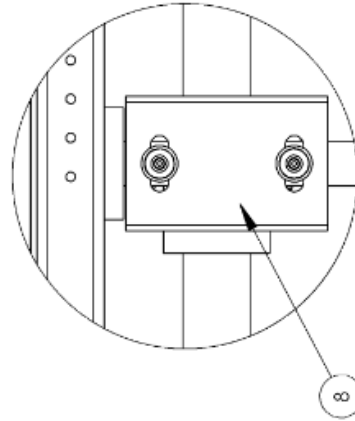
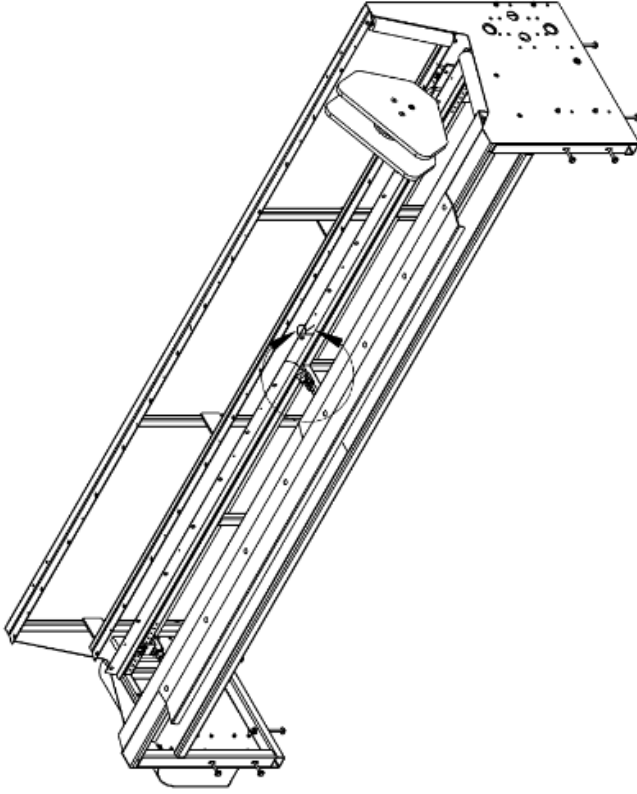

DETAIL C
SCALE 1 : 4

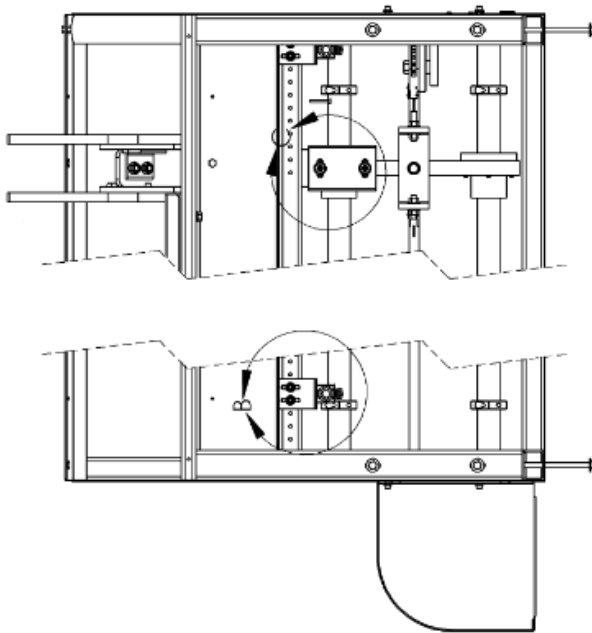
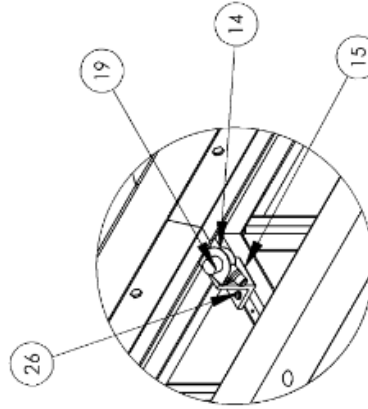

NOTE:
RANGE OF EJECTOR ARM MOVEMENT
CAN BE CONTROLLED BY CHOOSING
DIFFERENT TAPPED HOLE LOCATIONS.

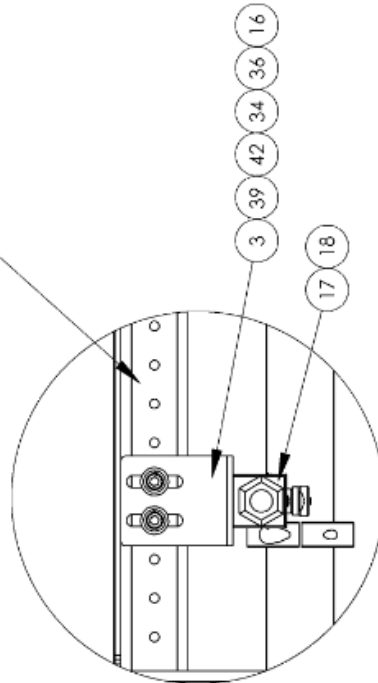

DETAIL B
SCALE 1 : 4

13061220 Motor Assembly, Off-Load Pusher

AAC Drawing Number 13061220 Rev 1

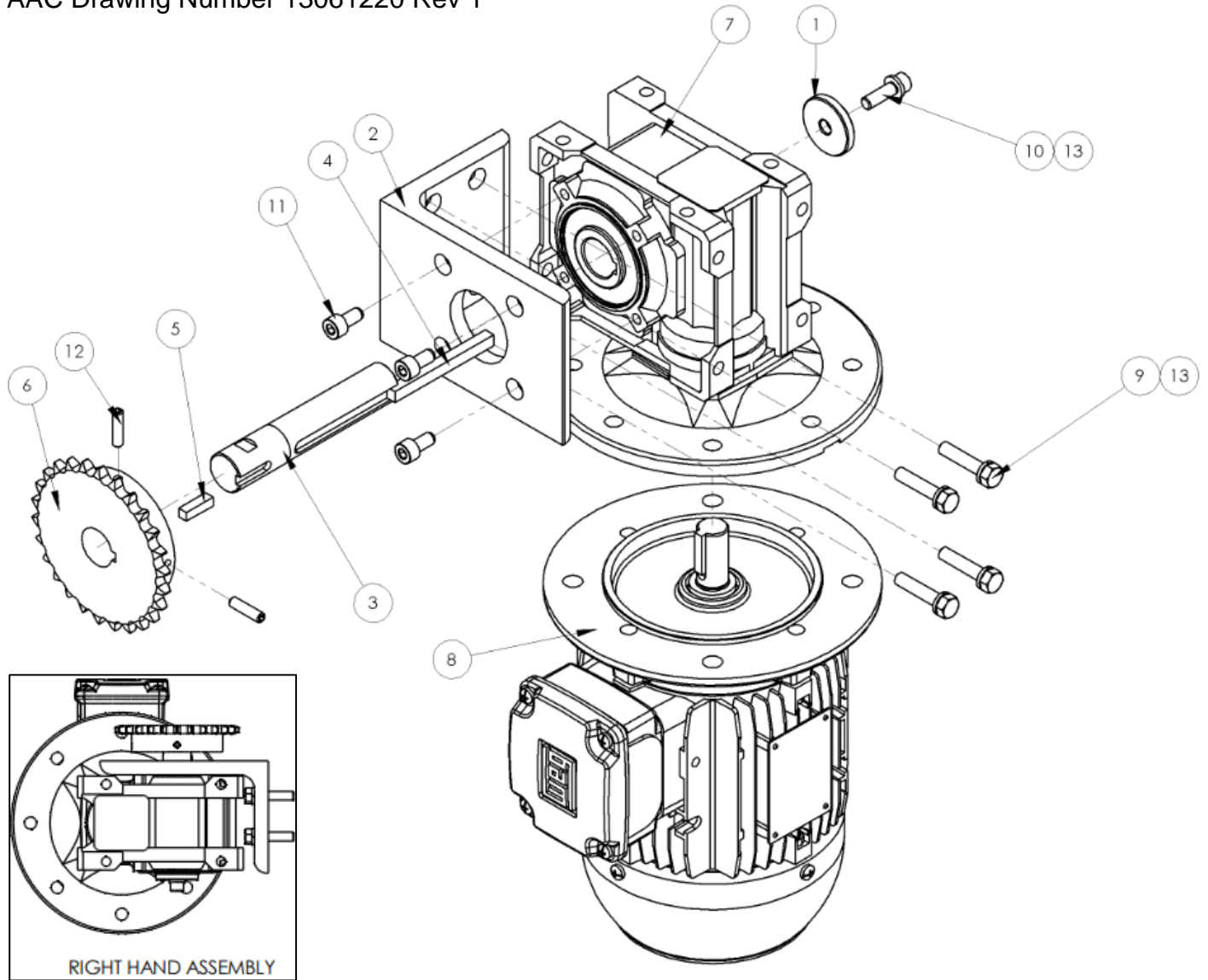

ITEM	QTY.	PART NUMBER	DESCRIPTION
1	1	1306005	RETAINER,SHAFT,GEARBOX
2	1	13061206	TROUGH, REINFORCED, MOTOR MOUNT
3	1	13061207	SHAFT,EJECTOR,RV50
4	1	13061208	KEY STOCK,8MMX7MMX3.25IN
5	1	13453507	KEY,1/4X1/4X7/8L, TOOL ST
6	1	MMH4026X1	SPROCKET,# 40,26HT,1"B
7	1	MMRV5030D80	GEARBOX,WORM,RV50,30:1
8	1	MMYS801455	MOTOR,,55KW,IEC,B5,D80
9	4	SSHC10096	5/16-18 X 1-1/2 HHCS
10	1	SSSC10064	5/16-18 X 1 SOCKET CAP
11	4	SSSCM8X16	SCREW,SOC CAP,M8X16
12	2	SSSS01016	1/4-20 X 1/4 KNURL PT
13	5	WWL5/16	WASHER,LOCK, 5/16

13061325 Pusher, Paddle Assembly

AAC Drawing Number 13061325 Rev 0

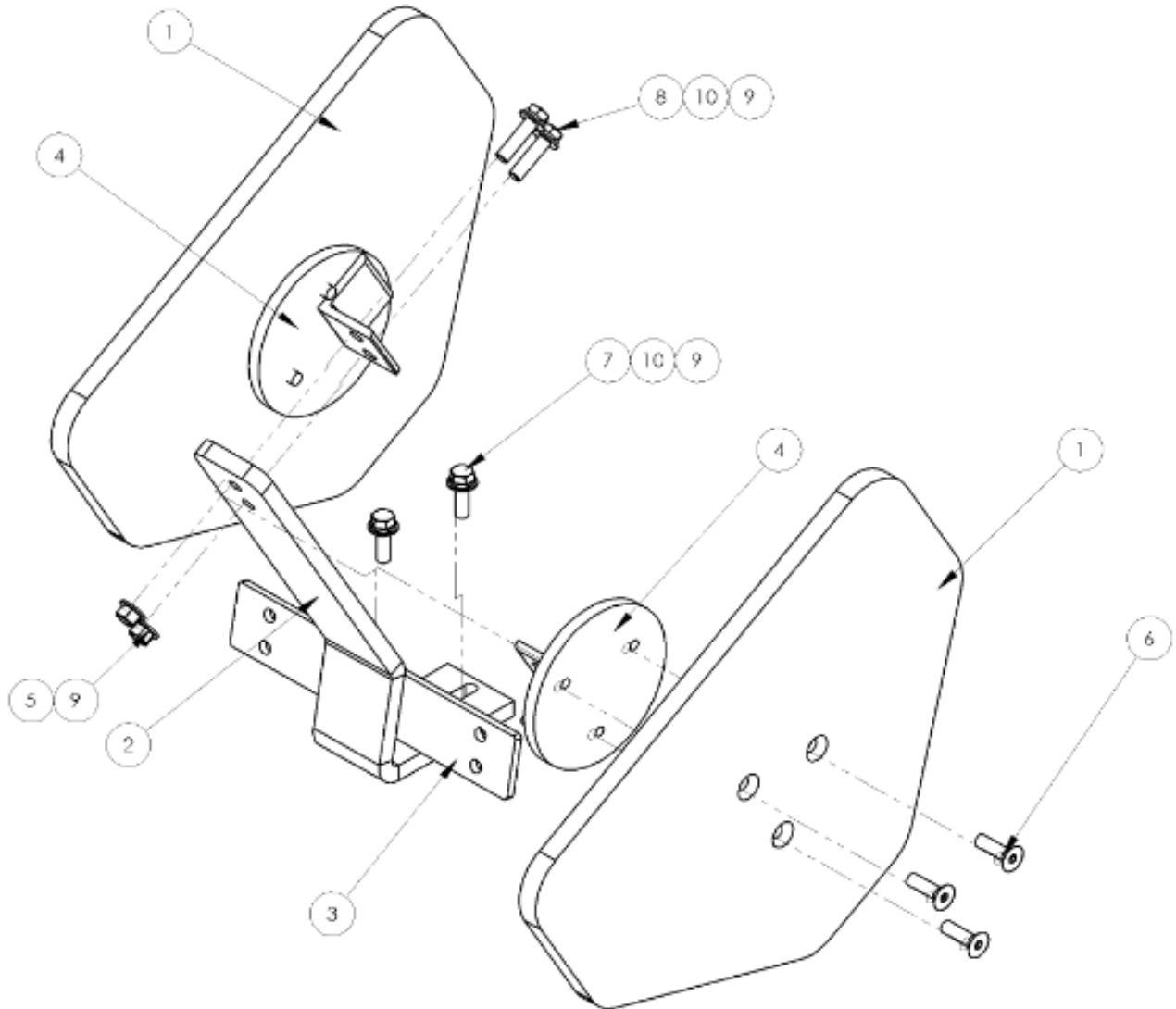

ITEM	QTY.	PARTNUMBER	DESCRIPTION
1	2	13061303	TROUGH, PUSH PAD, REINFORCED VER.
2	1	13061304	TROUGH, PUSH ARM, REINFORCED VER.
3	1	13061458	EXTENSION, PUSHER 8"
4	2	1306629	MOUNT,BRACKET,PUSHER
5	2	NNH3/8-16	NUT,HEX,3/8-16
6	6	SSFC25080	SCR,FLAT,HD,3/8-16X1-1/4
7	2	SSHC25080	3/8-16X1-1/4 HHCS
8	2	SSHC25096	3/8-16 X 1 1/2 HHCS
9	6	WWFS3/8	WASHER,FLAT,SAE,3/8
10	4	WWL3/8S	WASHER, LOCK, 3/8,S/S

13061329 Ejector Arm Mount Assembly

AAC Drawing Number 13061329 Rev 0

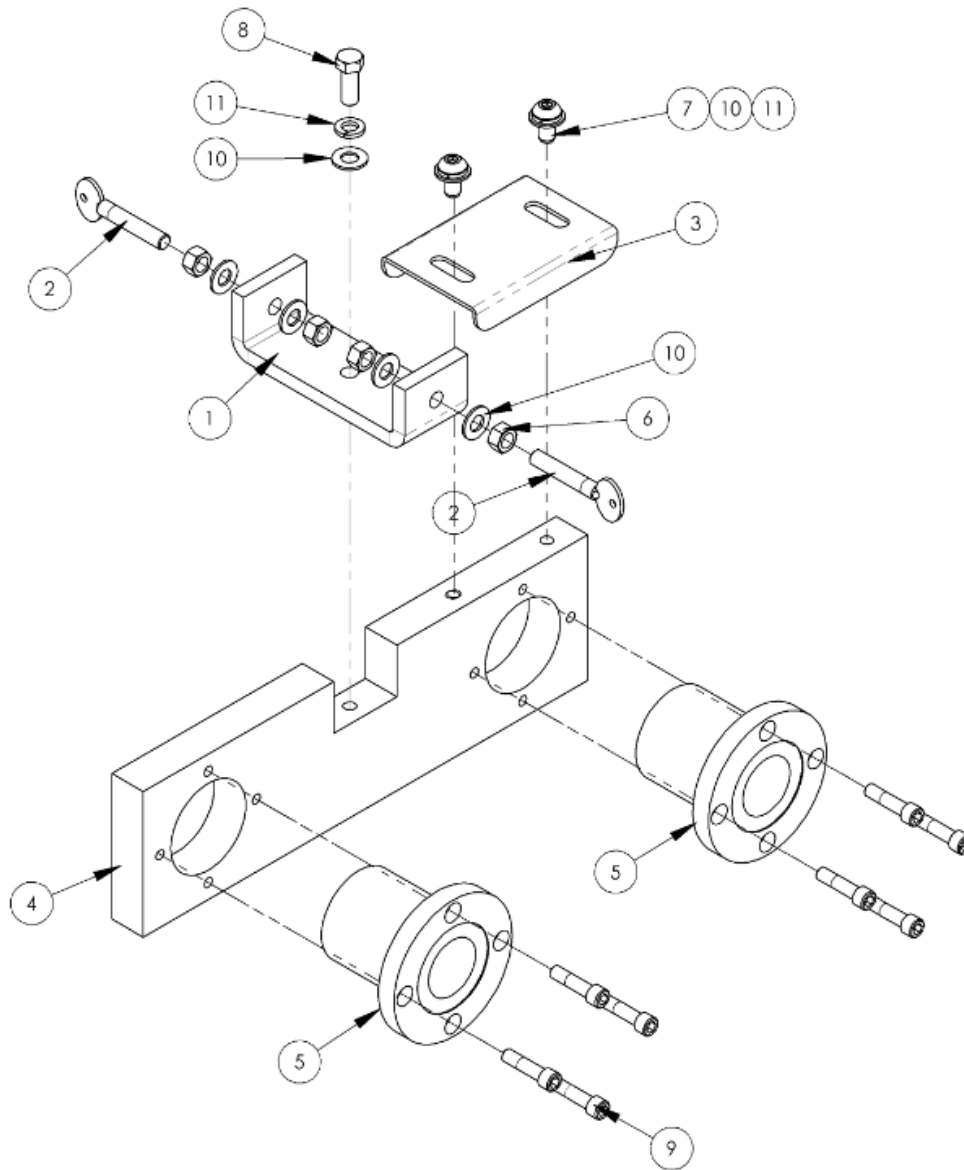

ITEM #	QTY.	PART #	DESCRIPTION
1	1	1306025	MOUNT,DRIVE CHAIN
2	2	1306026	MODIFIED THUMB SCREW
3	1	13061122	LIMIT SWITCH TRIGGER / FAIL-SAFE STOPPER
4	1	13061331	MOUNT,EJECTOR ARM
5	2	BBULHFR150	BEARING,LINER,1.5 B
6	4	NNH3/8-16	NUT,HEX,3/8-16
7	2	SSBC25048	3/8-16 X 3/4 BUT CAP SCR
8	1	SSHC25064	3/8-16 X 1,HEX CAP
9	8	SSSC10080S	5/16-18 X 1-1/4 SOC CAP
10	7	WWFS3/8	WASHER,FLAT,SAE,3/8
11	3	WWL3/8	WASHER,LOCK, 3/8

13061351 Sprocket Assembly, Inside

AAC Drawing Number 13061351 Rev 0

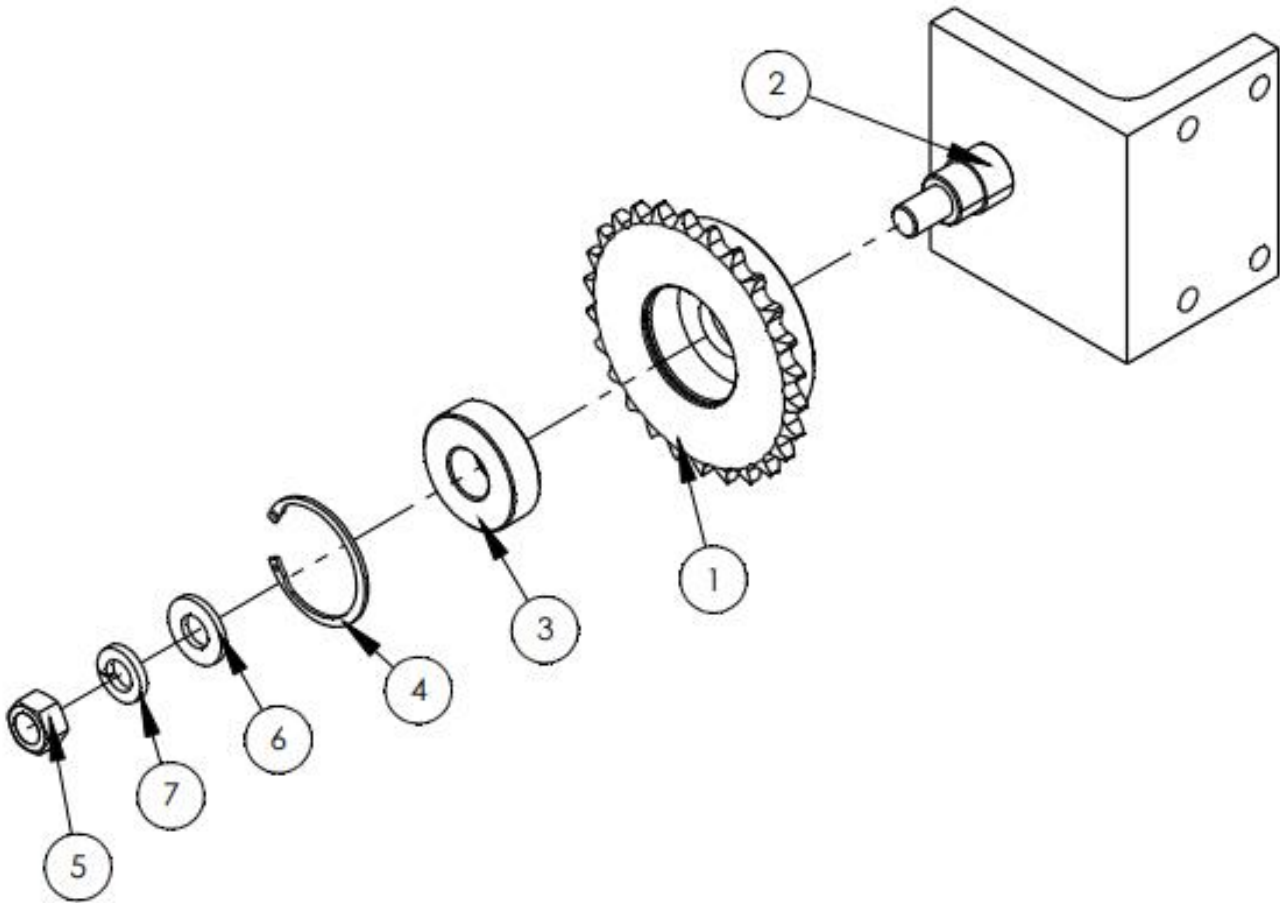

ITEM #	QTY.	PART #	DESCRIPTION
1	1	1306027	SPROCKET,#40,26HT,BEARING
2	1	13061352	BEARING MTG, WLDMNT
3	1	BB1L017	BEARING,BALL, .787B
4	1	MM98409A244	E-RING, INT, 1-7/8 X .068
5	1	NNH1/2-13	NUT,HEX,1/2-13
6	1	WWFS1/2	WASHER,FLAT,1/2, SAE
7	1	WWL1/2	1/2 LOCK WASHER

13061330 Guarding and Shields, Outfeed

AAC Drawing Number 13061330 Rev 1

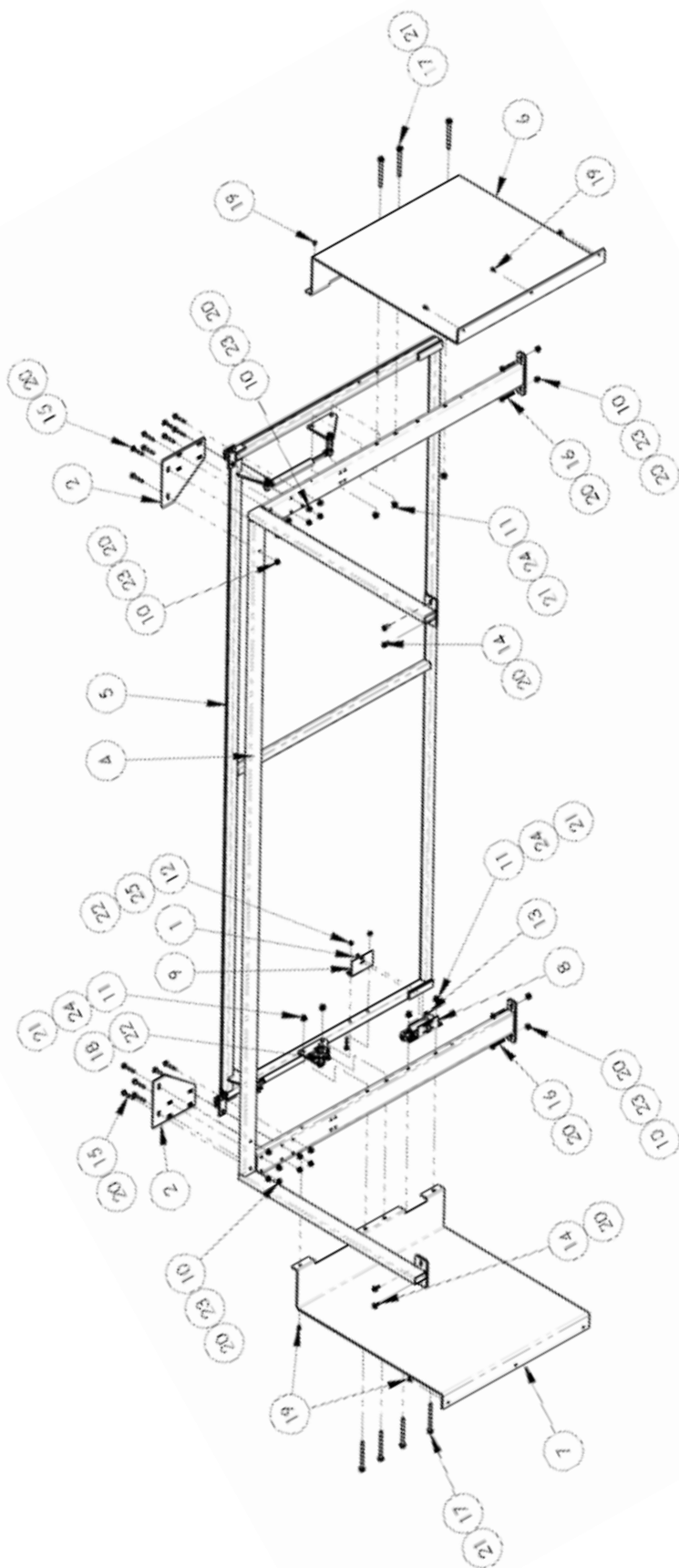

ITEM	QTY.	PART #	DESCRIPTION
1	1	1060008	PLATE,NUT,8-32X.50
2	2	1306743	CORNER BRACE
3	2	13061335	VERTICAL DOOR SUPPORT
4	1	13061340	UPPER DOOR SUPPORT
5	1	13061344	OUTFEED GUARD DOOR
6	1	13061347	OUTFEED SIDE GUARD
7	1	13061473	OUTFEED SIDE GUARD, MIRRORED 13061347
8	1	13901091	SAFETY INTERLOCK SWITCH ASSY
9	1	13901093	DOOR KEY BRACKET
10	20	NNH1/4-20	NUT,HEX,1/4-20
11	7	NNH5/16-18	NUT,HEX, 5/16-18
12	2	NNH10-32	HEX-NUT 10-32 REG.
ITEM	QTY.	PART #	DESCRIPTION
13	2	SSBC90024	8-32X3/8 BUTTON CAP
14	4	SSHC01048	1/4-20 X 3/4 HEX CAP
15	16	SSHC01112	1/4-20 X 1-3/4 HHCS
16	4	SSHC01128	1/4-20 X 2 HEX CAP
17	7	SSHC10256	5/16-18 X 4.0 HEX CAP
18	2	SSHC98096	#10-32 X 1-1/2 HEX CAP
19	8	SSZS93032	SCREW, SHT.METAL 10 ZIP
20	44	WWFS1/4	WASHER,FLAT,SAE,1/4
21	14	WWFS5/16	WASHER,FLAT,SAE,5/16
22	4	WWFS10	WASHER, FLAT, #10, SAE
23	20	WWL1/4	WASHER,LOCK, 1/4
24	7	WWL5/16	WASHER,LOCK, 5/16
25	2	WWL10	WASHER,LOCK,#10

14061500 Fold-in-half Conveyor

AAC Drawing Number 14061500 Rev 2

14061500--Sheet 1:

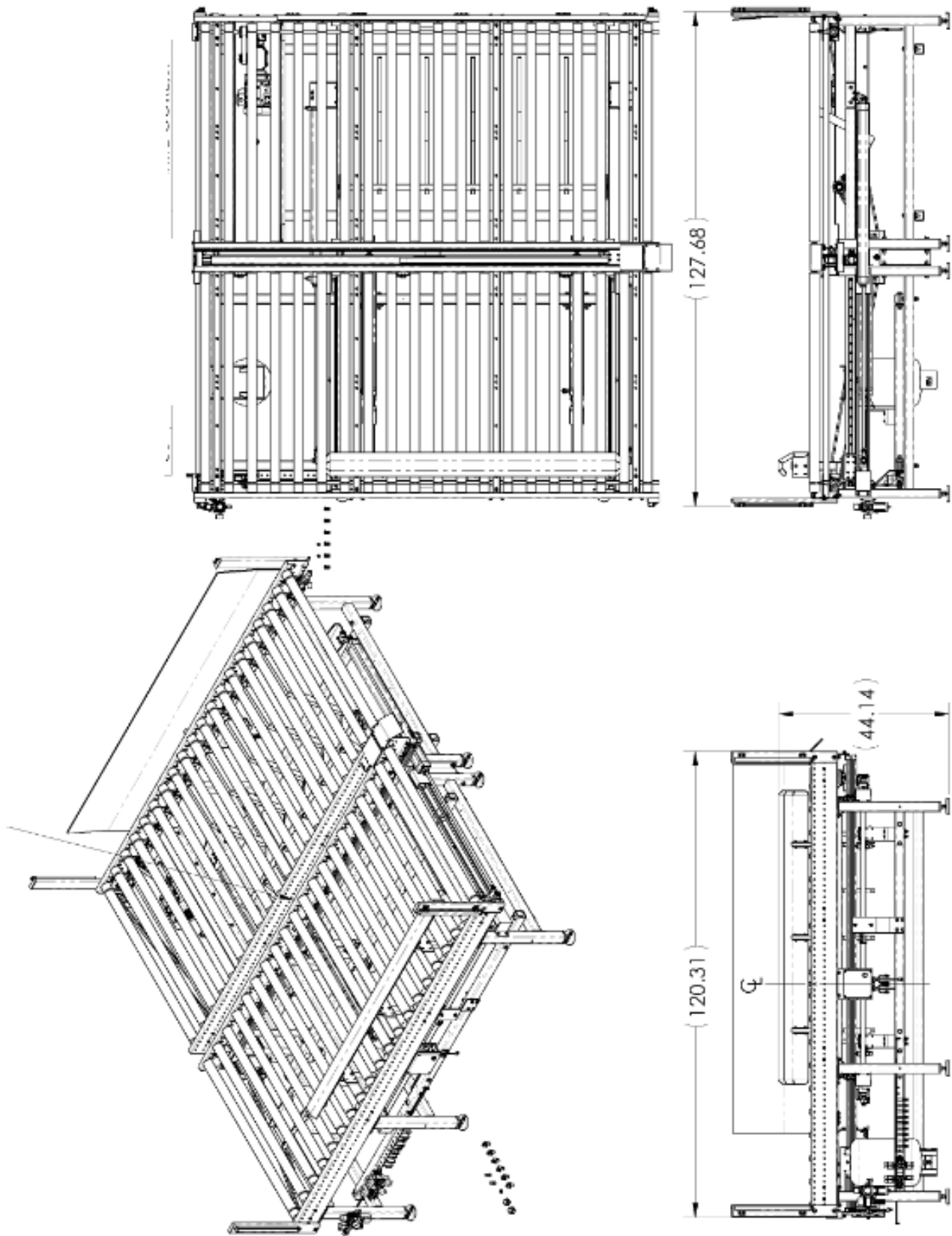

14061500--Sheet 2:

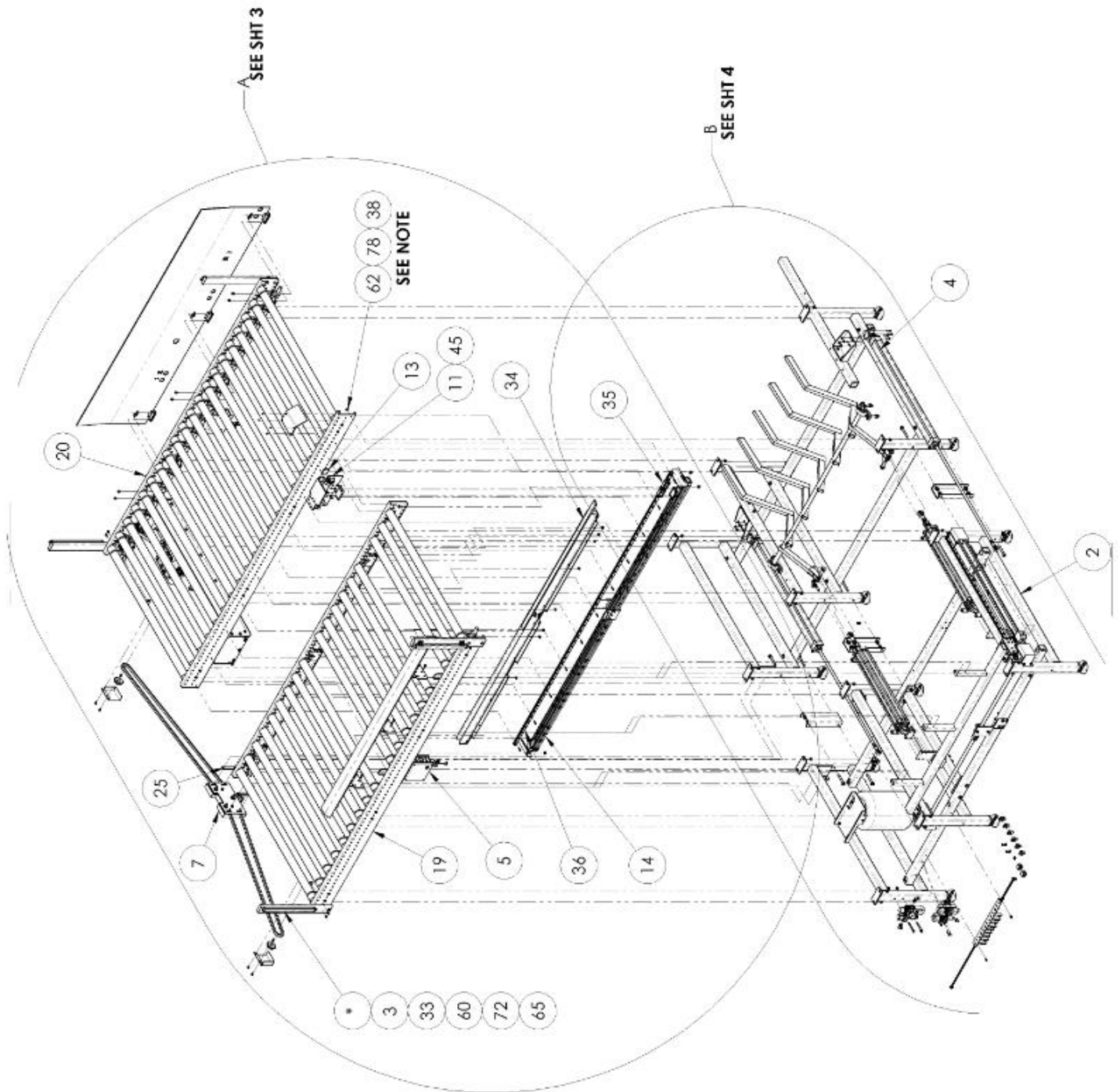

14061500 parts list

ITEM	QTY	PART NUMBER	DESCRIPTION	ITEM	QTY	PART NUMBER	DESCRIPTION
1	2	13451026	KEY,1/4 x 1.0L	43	2	OY0335	18" LIGHT CURTAIN
2	1	14061230	CONVEYOR FRAME ASSY, LEFT	44	4	SSFC98032	10-32 X 1/2 FLAT ALLEN CAP
3	4	14061234	LIGHT CURTAIN MTG TUBE	45	8	SSFCM6X20	M6 X 20 FLAT ALLEN
4	1	14061235	CONVEYOR FRAME ASSY, RIGHT	46	10	SSHC01040	1/4-20 X 5/8 HHCS
5	2	14061236	LIGHT CURTAIN CONTROL ASSY	47	6	SSHC10040	5/16-18 X 5/8 HHCS
6	1	14061242	CHAIN, #40 X 245" LONG	48	5	SSHC25048	3/8-16X3/4,HEX CAP
7	1	14061245	SPROCKET IDLER ASSY	49	22	SSHC25064	3/8-16 X 1,HEX CAP
8	2	14061246	SPROCKET GUARD MTG BRKT	50	28	SSHC25080	3/8-16X1-1/4 HHCS
9	1	14061247	SPROCKET GUARD, LEFT	51	2	SSHC25224	3/8-16 X 3.5 HEX CAP
10	1	14061248	SPROCKET GUARD, RIGHT	52	2	SSHC34160	3/4-10 X 2-1/2 HEX CAP
11	1	14061250	PUSHER ASSEMBLY	53	1	SSHC42080	5/8-18X1.25 HEX CAP
12	1	14061260	CABLE TRACK GUIDE ASSY	54	1	SSHC42160	5/8-18X2-1/2 HEX CAP
13	2	14061264	LINEAR BEARING SPACER	55	12	SSHC45256	1/2-13X4 HEX CAP
14	1	14061270	PUSHER TRANSFER ASSY	56	11	SSSC01064	1/4-20 X 1 SOC CAP
15	3	14061273	FRAME SPACER	57	8	SSSC10080	5/16-18 X 1-1/4 SOC CAP
16	2	14061274	PUSHER CYLINDER ASSY	58	8	SSSC25064	3/8-16X1 SOC CAP
17	2	14061275	CONTROL ASSY MTG BRKT	59	4	SSSC90080	#8-32 X 1-1/4 SOC CAP SC
18	3	14061278	LOWER SENSOR ASSEMBLY	60	16	SSSC98032	10-32X1/2, SOC CAP
19	1	14061280	LEFT CONVEYOR ASSY, 60" X 10FT	61	4	SSSCM6X15	M6X15 SOC CAP SCREW
20	1	14061290	RIGHT CONVEYOR ASSY, 60" X 10FT	62	11	WWF1/4	WASHER, FLAT, 1/4", COM
21	1	14061295	SOLENOID,4 VALVE ASM	63	24	WWFS1/2	WASHER,FLAT,1/2, SAE

14061500--Sheet 3:

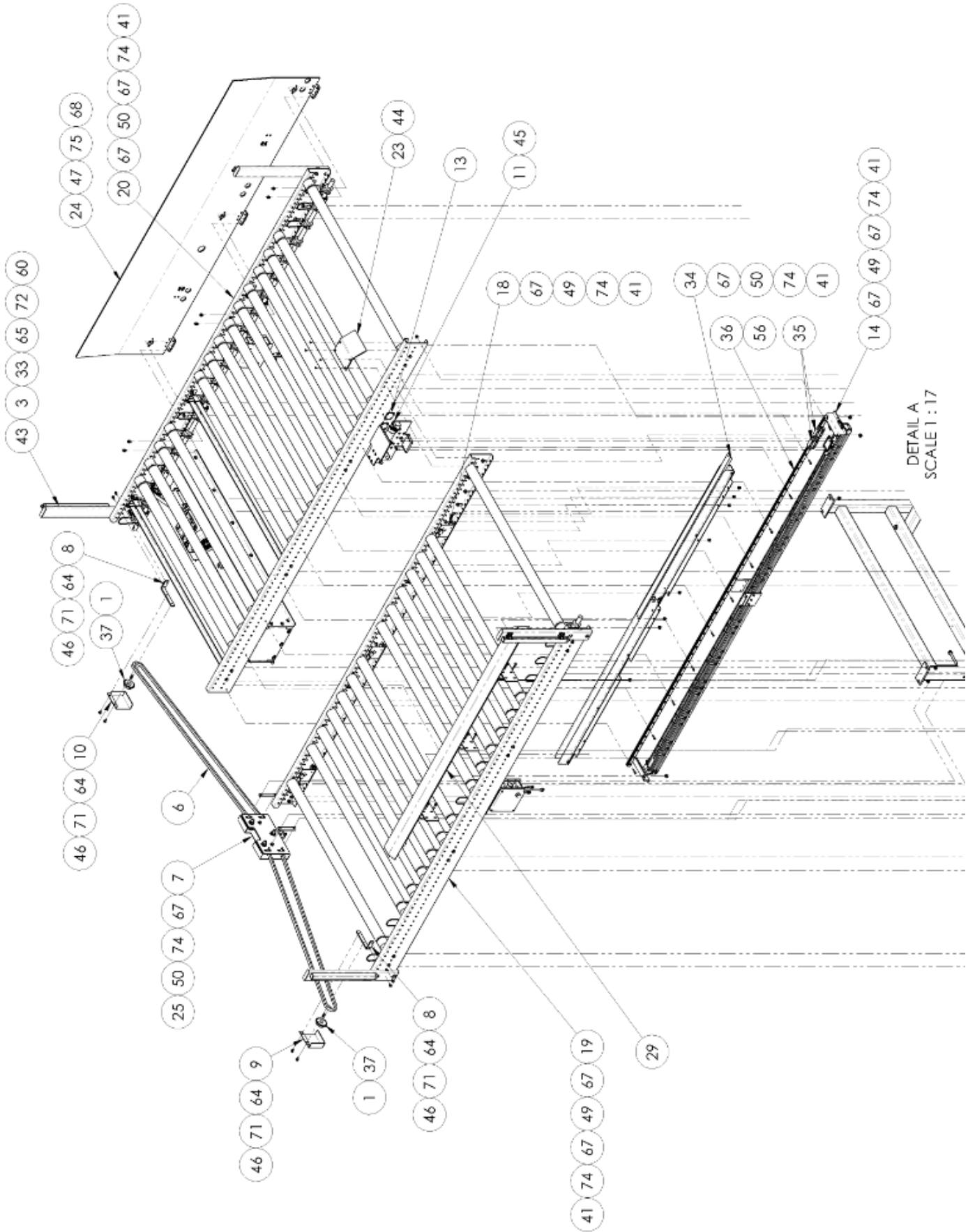

DETAIL A
SCALE 1:17

14061500 parts list
continued

ITEM	QTY	PART NUMBER	DESCRIPTION	ITEM	QTY	PART NUMBER	DESCRIPTION
22	1	14061300	ELECTRICAL PANEL, FIH, 11306FF	64	10	WWFS1/4	WASHER,FLAT,SAE,1/4
23	1	14061306	INFEEED RAMP	65	16	WWFS10	WASHER, FLAT, #10, SAE
24	1	14061310	RIGHT SIDE GUARD ASSY	66	4	WWFS3/4	WASHER, .797ID X 1-1/2OD
25	2	14061321	PLATE, NUT, 3/8-16@4.0CTC	67	93	WWFS3/8	WASHER,FLAT,SAE,3/8
26	1	14061500-CAB	CABLE KIT, 14061500	68	14	WWFS5/16	WASHER,FLAT,SAE,5/16
27	1	14061500-PD	DIAGRAM, PNEUMATIC	69	2	WWFS5/8	WASHER,FLAT,5/8,SAE
28	2	1406382	CYL ASSY, DNSB80X710	70	12	WWL1/2	1/2 LOCK WASHER
29	1	1406545	PUSH PLATE ASSEMBLY	71	10	WWL1/4	WASHER,LOCK, 1/4
30	1	AA198-AW40	REGULATOR ASSY,W/LOCKOUT	72	16	WWL10	WASHER,LOCK,#10
31	1	AAFAN300-N03	MUFFLER,3/8NPT,PLASTIC	73	2	WWL3/4	3/4 LOCK WASHER
32	2	AAQME-2-2	ELBOW, MALE,1/2 OD TUBE	74	57	WWL3/8	WASHER,LOCK, 3/8
33	4	MM132-1X3	END CAP,RECT,BLACK,1X3	75	14	WWL5/16	WASHER,LOCK, 5/16
34	1	MM182302882	MICRO TRACK, 1.5X.71	76	2	WWL5/8	WASHER,LOCK 5/8
35	2	MMEGH25CA	LINEAR BEARING	77	4	WWL8	WASHER,LOCK,#8
36	1	MMEGR25R3040C	RAIL,LINEAR, EG SERIES	78	11	WWS307-1	WASHER,SPRING,BELVEL
37	2	MMH4017X1	HT 17 ANSI 40 1" BORE	79	6	AAQUY-3-3	QUICK UNION Y 3/8 X 3/8
38	11	NNE1/4-20	NUT,ELASTIC LOCK,1/4-20	80	2	AAQSU-3-3	UNION,STRAIGHT,QUICK
39	12	NNH1/2-13	NUT,HEX,1/2-13	81	1	4080-940	MODULE,TERMINATOR
40	2	NNH3/4-10	NUT,HEX,3/4-10	82	5	12788-509	CABLE,JUMPER,OUTPUT
41	55	NNH3/8-16	NUT,HEX,3/8-16	83	2	EE64151B	FERRITE CORE,SPLIT,CABLE
42	8	NNH5/16-18	NUT,HEX, 5/16-18				

14061500--Sheet 4:

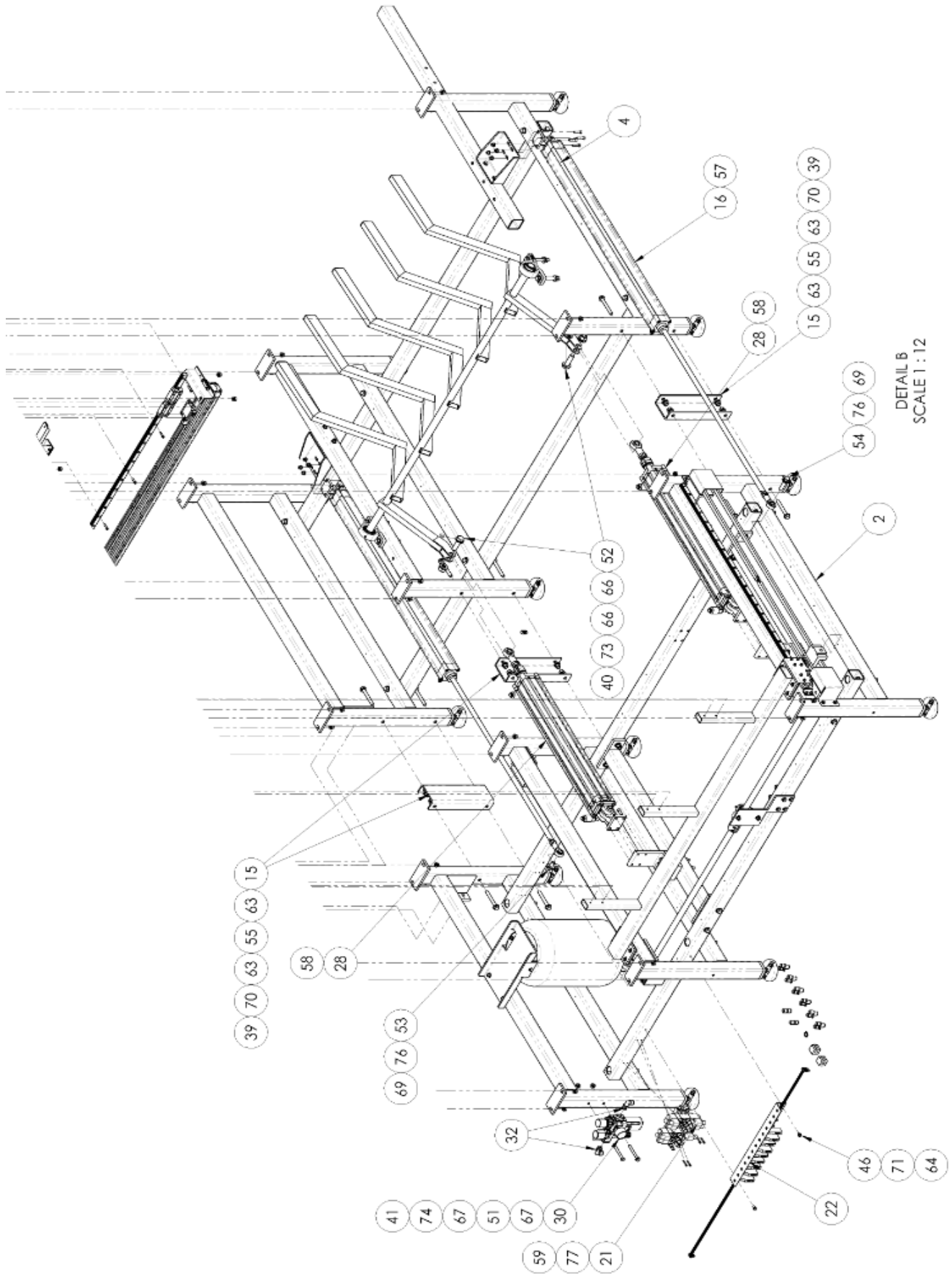

14061230 parts list

ITEM	QTY	PART NUMBER	DESCRIPTION	ITEM	QTY	PART NUMBER	DESCRIPTION
1	1	1306082	COUPLING,2-PIECE,1" BORE	24	3	MMUCP205-16	BEARING,PILLOW BLOCK,1"
2	2	13451026	KEY,1/4 x 1.0L	25	16	NNH3/8-16	NUT,HEX,3/8-16
3	2	14061183	SPROCKET GUARD, LEFT	26	2	NNJ5/16-18	NUT,JAM,5/16-18
4	2	14061186	SPROCKET GUARD, RIGHT	27	2	NNJ5/8-11	NUT,HEX JAM,5/8-11
5	1	14061199	PUSHER SIDE PLATE, RIGHT	28	8	SSHC01040	1/4-20 X 5/8 HHCS
6	1	14061201	PUSHER SIDE PLATE, LEFT	29	8	SSHC01056	1/4-20 X 7/8 HEX CAP
7	1	14061207	PILLOW BLOCK MOUNT	30	6	SSHC01064	1/4-20 X 1 HHCS
8	1	14061208	PUSH PLATE MTG WELDMENT	31	2	SSHC10128F	5/16-18 1X 2 FULL, HEX CAP
9	2	14061209	CHAIN, #40 X218" LONG	32	6	SSHC25096	3/8-16 X 1 1/2 HHCS
10	2	14061214	PUSHER DRIVE SHAFT	33	6	SSHC25224	3/8-16 X 3.5 HEX CAP
11	2	14061216	DRIVE BLOCK	34	8	SSHC25384	3/8-16X6,HEX CAP
12	1	14061221	CONVEYOR FRAMEWORK, LEFT	35	2	SSHC41160	5/8-11 X2-1/2 HEX CAP
13	2	14061224	CYLINDER PIVOT MOUNT	36	30	SSSC05048	1/4-28 X 3/4, SOC CAP
14	1	14061282	AIR TANK ASSY.	37	8	SSSC98072	10-32 X 1-1/8 SOC CAP
15	2	14061299	FOLD CYL MTG SPACER	38	16	SSSCM6X16	M6 X 16, SOC CAP
16	2	1406432	RAIL STOP, 10 GA	39	26	WWFS1/4	WASHER,FLAT,SAE,1/4
17	2	1406445	CHAIN CLAMP	40	36	WWFS3/8	WASHER,FLAT,SAE,3/8
18	2	1406448	IDLER SPROCKET JACK	41	2	WWFS5/8	WASHER,FLAT,5/8,SAE
19	2	1493196	STOP, LINEAR BEARING	42	26	WWL1/4	WASHER,LOCK, 1/4
20	4	MMEGH25CA	LINEAR BEARING	43	8	WWL10	WASHER,LOCK,#10
21	2	MMEGR25R1340C	RAIL,LINEAR, AG 1340MM	44	20	WWL3/8	WASHER,LOCK, 3/8
22	2	MMH4017X1	HT 17 ANSI 40 1" BORE	45	2	WWL5/8	WASHER,LOCK 5/8
23	2	MMHB40A17	SPROCKET, IDLER, 1/P,	46	16	WWLM6	WASHER,LOCK,M6

14061235 Conveyor Frame Assembly, Right

AAC Drawing Number 1406235 Rev 1

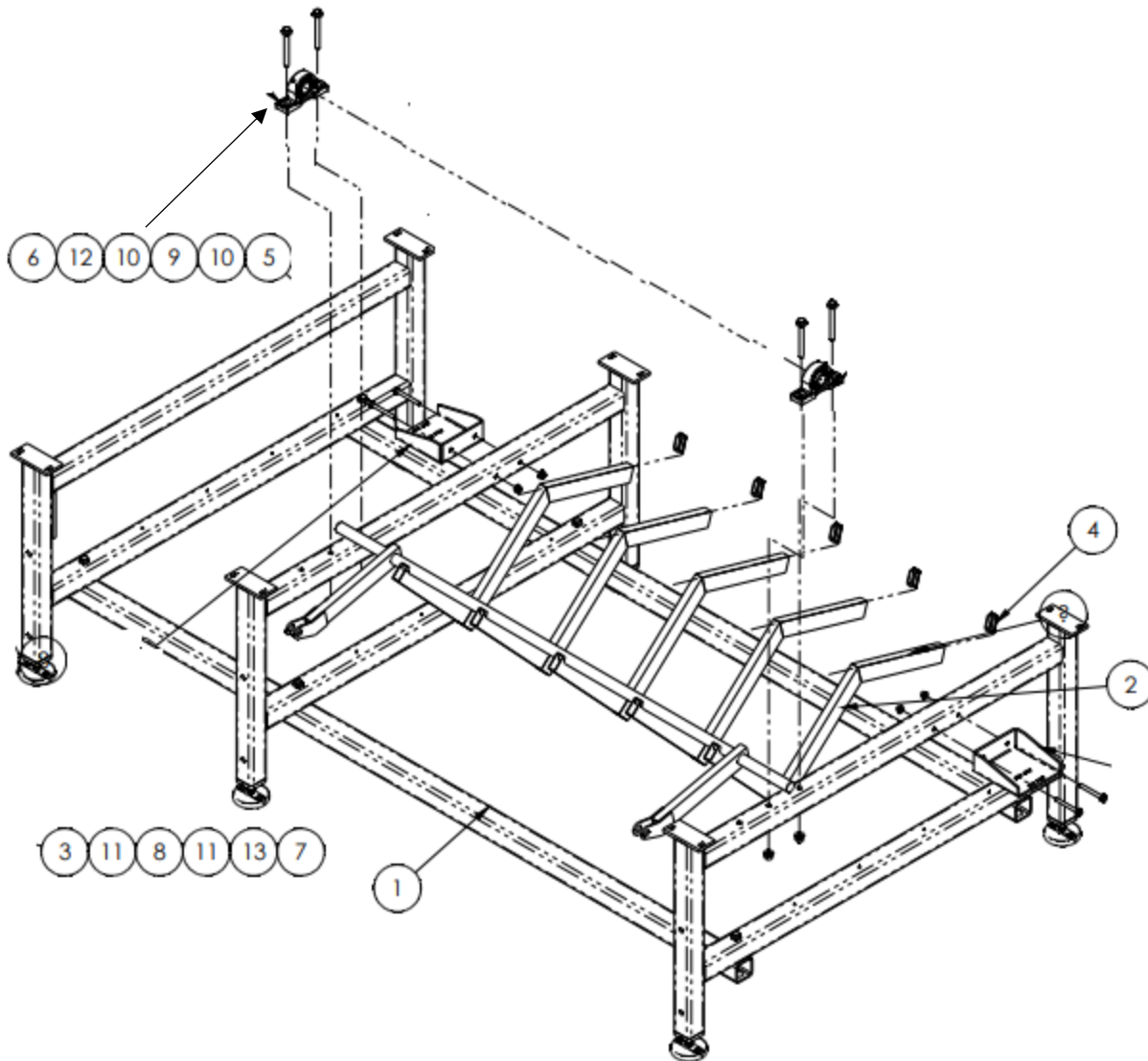

ITEM	QTY	PART NUMBER	DESCRIPTION
1	1	14061222	CONVEYOR FRAMEWORK, RIGHT
2	1	14061232	FOLD ARMS WELDMENT
3	2	14061233	CYLINDER MTG BRKT
4	5	MM132-1496	PLUG 1 X 2
5	2	MMUCP206-20	BEARING,PILLOWBLOCK,1.25B
6	4	NNH1/2-13	NUT,HEX,1/2-13
7	4	NNH3/8-16	NUT,HEX,3/8-16
8	4	SSHC25224	3/8-16 X 3.5 HEX CAP
9	4	SSHC45288	1/2-13X4-1/2 HEX CAP
10	8	WWFS1/2	WASHER,FLAT,1/2, SAE
11	8	WWFS3/8	WASHER,FLAT,SAE,3/8
12	4	WWL1/2	1/2 LOCK WASHER
13	4	WWL3/8	WASHER,LOCK, 3/8

14061236 Light Curtain Control Assembly

AAC Drawing Number 14061236 Rev 0

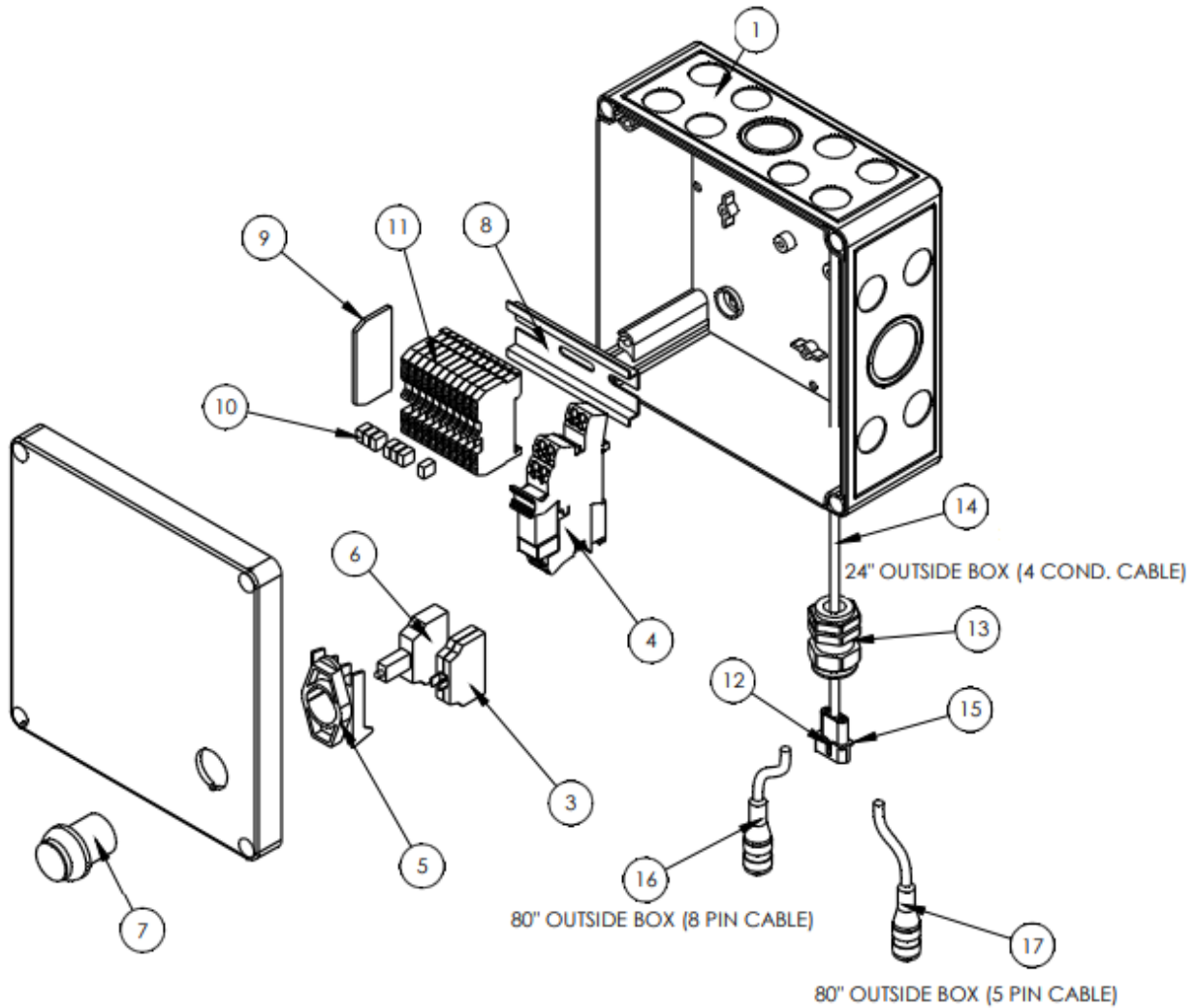

ITEM	QTY.	PART NUMBER	DESCRIPTION
1	1	1396884	JUNCTION BOX MODIFIED
2	1	14061236-WD	WIRING DIAGRAM, LIGHT CURTAIN
3	1	EE3X10	BLOCK,P.B. CONTACT, N.O. (GRN)
4	1	EE788312	RELAY,24V,DPDT,WAGO
5	1	EEA3L	LATCH,PUSH BUTTON
6	1	EED7-N3W	LED BLOCK, 22MM, 24V LAMP
7	1	EEPLE4	BUTTON, PUSH, RED, ILLUM
8	1	EETS35X7.5A	DIN RAIL-AMERICAN
9	1	FF280-308	TERMBLK ENDPLATE,WAGO,280
10	7	FF280-402	JUMPER,WAGO,TOP,SNGL
11	11	FF280-901	TERMBLK,WAGO,TOP,SNGL,GRY
12	3	FF31F1022	PIN, MALE .093, MOLEX TYPE
13	1	FF3216	STRAIN RELIEF, LIQ TIGHT
14	3 FT	FF36F041 WA	CABLE,4 COND,22 AWG
15	1	FF59F1803	3 PIN MALE CONN
16	1	FFE12166	CABLE, 8 PIN MICRO, 5M L
17	1	FFEVC071	CABLE, 5 PIN MICRO, 5M L

14061245 Sprocket Idler Assembly

AAC Drawing Number 14061245 Rev 0

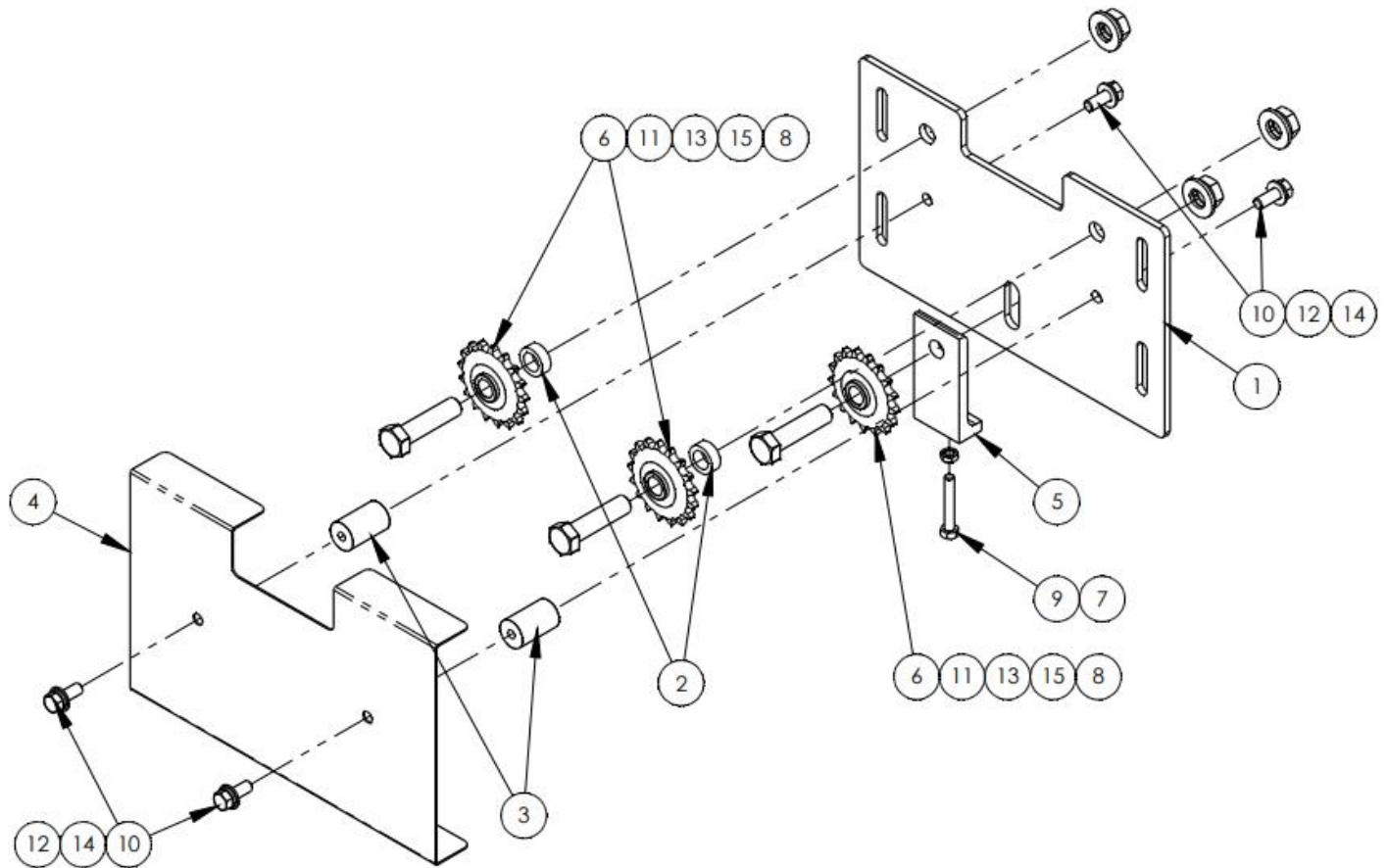

ITEM	QTY.	PART NUMBER	DESCRIPTION
1	1	14061239	IDLER MTG PLATE
2	2	14061241	SPROCKET IDLER SPACER
3	2	14061243	SPROCKET COVER SPACER
4	1	14061244	SPROCKET IDLER COVER
5	1	1406448	IDLER SPROCKET JACK
6	3	MMHB40A17	SPROCKET, IDLER, 1/P,
7	1	NNJ5/16-18	NUT, JAM, 5/16-18
8	3	NNJ5/8-11	NUT, HEX JAM, 5/8-11
9	1	SSHC10128F	5/16-18 1X 2 FULL, HEX CAP
10	4	SSHC25064	3/8-16 X 1, HEX CAP
11	3	SSHC41160	5/8-11 X 2-1/2 HEX CAP
12	4	WWFS3/8	WASHER, FLAT, SAE, 3/8
13	3	WWFS5/8	WASHER, FLAT, 5/8, SAE
14	4	WWL3/8	WASHER, LOCK, 3/8
15	3	WWL5/8	WASHER, LOCK 5/8

14061250 Pusher Assembly

AAC Drawing Number 14061250 Rev 0

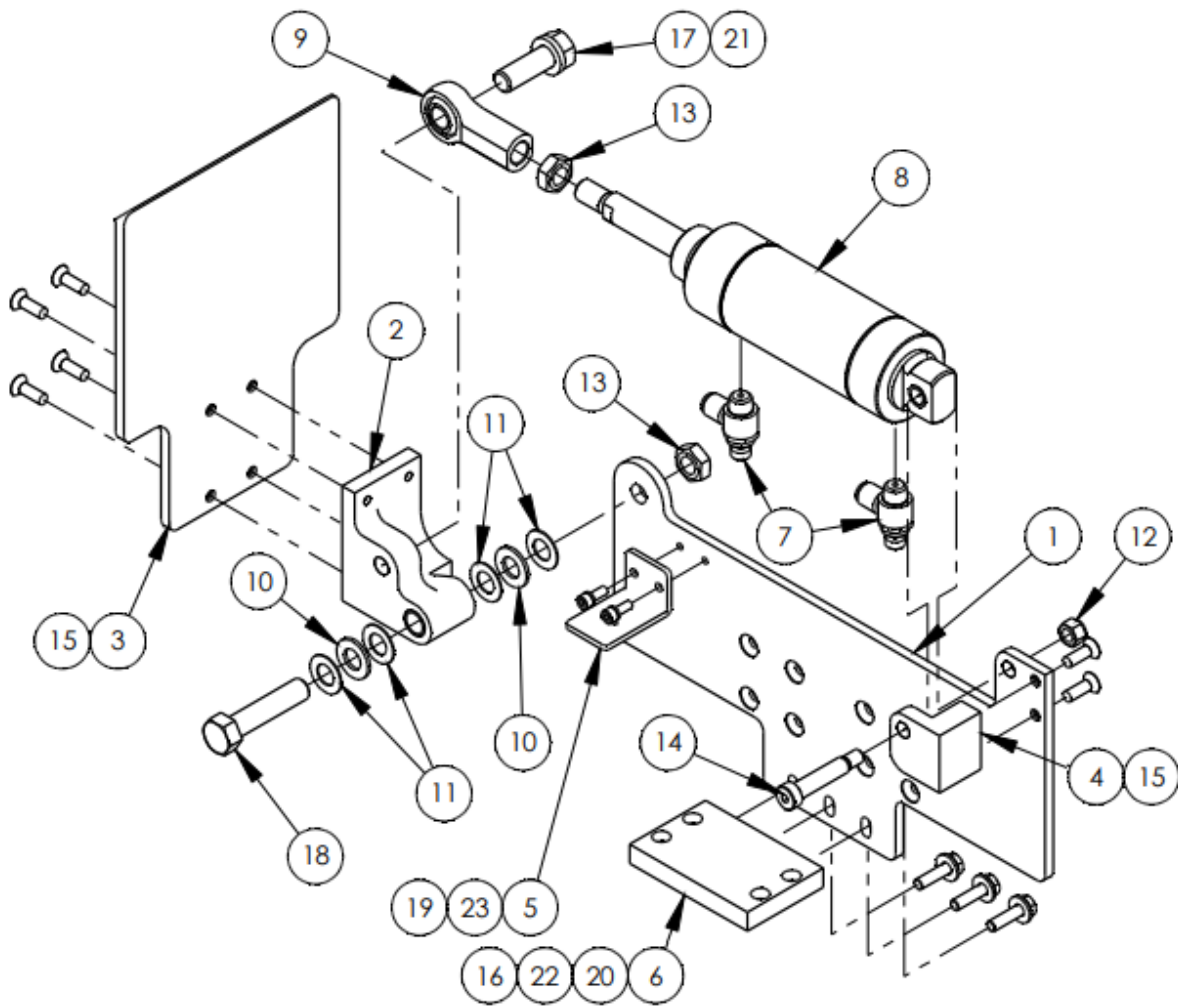

ITEM	QTY.	PART NUMBER	DESCRIPTION	ITEM	QTY.	PART NUMBER	DESCRIPTION
1	1	14061249	PUSHER MTG PLATE	13	2	NNJ1/2-20	NUT, JAM, 1/2-20
2	1	14061251	PUSHER PIVOT BLOCK	14	1	SSAS024096	SHULDER BOLT 3/8 X
3	1	14061252	PUSHER PLATE	15	6	SSFC01048	1/4-20 X 3/4 FLAT CAP
4	1	14061253	CYLINDER PIVOT BLOCK	16	3	SSHHC01064	1/4-20 X 1 HHCS
5	1	14061254	CABLE TRACK MOUNT	17	1	SSHHC45096	1/2-13X1-1/2 HEX CAP
6	1	14061263	MOMENT COMPENSATOR MOUNT	18	1	SSHHC46144	1/2-20X2-1/4 HEX CAP
7	2	AA2201-07	FLOW CONTROL,1/4TX1/4NPT	19	2	SSSC98032	10-32X1/2, SOC CAP
8	1	AACM312DXPK	CYLINDER, AIR, DA W/MAG 2" BORE	20	3	WWFS1/4	WASHER,FLAT,SAE,1/4
9	1	BBAW-8Z	BEARING,ROD END,FEMALE	21	1	WWL1/2	1/2 LOCK WASHER
10	2	BBNTA815	BEARING,THRUST,1/2BORE	22	3	WWL1/4	WASHER,LOCK, 1/4
11	4	BBTRA815	WASHER,THRUST,STEEL 1/2	23	2	WWL10	WASHER,LOCK,#10
12	1	NNE5/16-18	NUT,ELASTIC LOCK,5/16-18				

14061270 Pusher Transfer Assembly

AAC Drawing Number 14061270 Rev 1

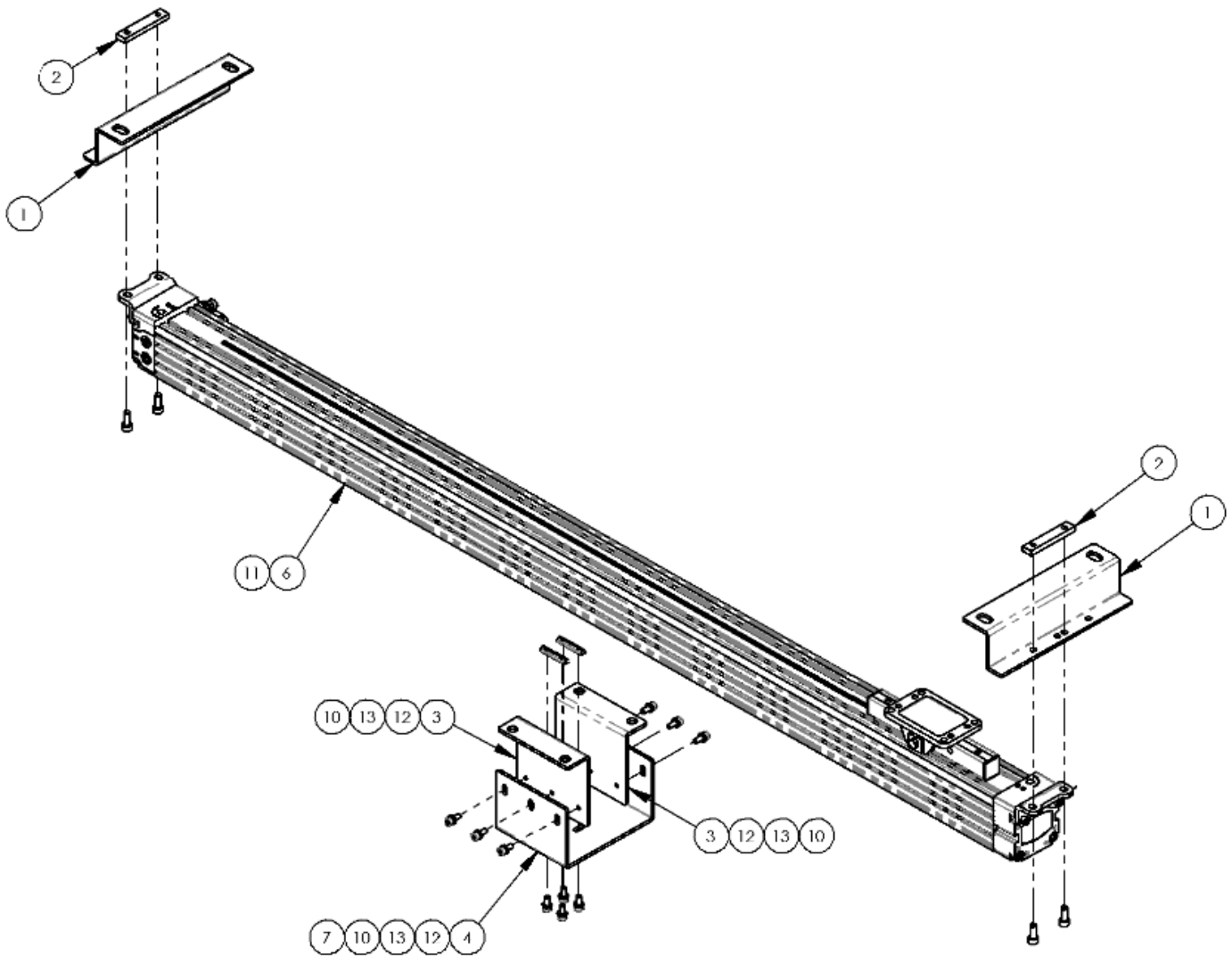

ITEM	QTY.	PART NUMBER	DESCRIPTION
1	2	14061265	CYLINDER END MTG BRKT
2	2	14061266	NUT PLATE, M6 X 45MM CTC
3	2	14061267	CYLINDER SUPPORT MTG BRKT
4	1	14061268	CYLINDER SUPPORT BRKT
5	2	AA1982201FU0211	FLOW CONTROL, 1/4 UNIFIT X 3/8
6	1	AACDGC402700	CYLINDER, AIR, RODLESS
7	2	AAFMUP-32/40	SLOT NUT FOR DGC-K CYLINDER
8	1	DARDL140S	MOMENT COMPENSATOR FOR DGC40 CYL
9	1	HP-40	FOOT MTG BRKT FOR DGC40 CYL
10	10	SSSCM5X12	M5 X 12 SOC CAP SC
11	4	SSSCM6X16	M6 X 16, SOC CAP
12	10	WWFM5	WASHER, FLAT, M5 I.D.
13	10	WWLM5	M5 LOCK WASHER

14061274 Pusher Cylinder Assembly

AAC Drawing Number 14061274 Rev 1

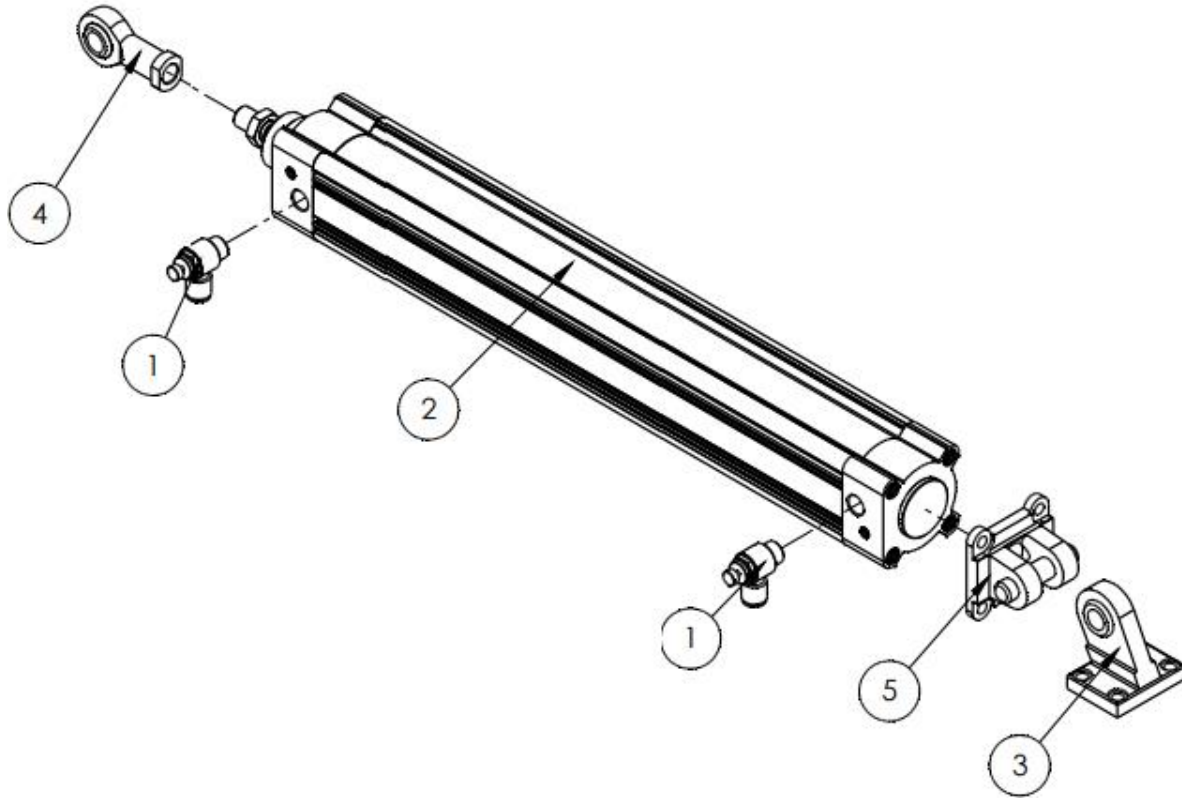

ITEM	QTY.	PART NUMBER	DESCRIPTION
1	2	AA1983201FU0311	FLOW CONTL 3/8UNIFIT X3/8
2	1	AACDNCB631050PPV	CYLINDER, AIR, ISO, 63BX1050S
3	1	AAFLSNG63	CLEVIS FOOT MOUNT,SWIVEL,
4	1	AAFSGSM16x15	BEARING,ROD END,16MM
5	1	AAFSNC63	BRTK,REAR PIVOT,63MM BORE

14061278 Lower Sensor Assembly

AAC Drawing Number 14061278 Rev 0

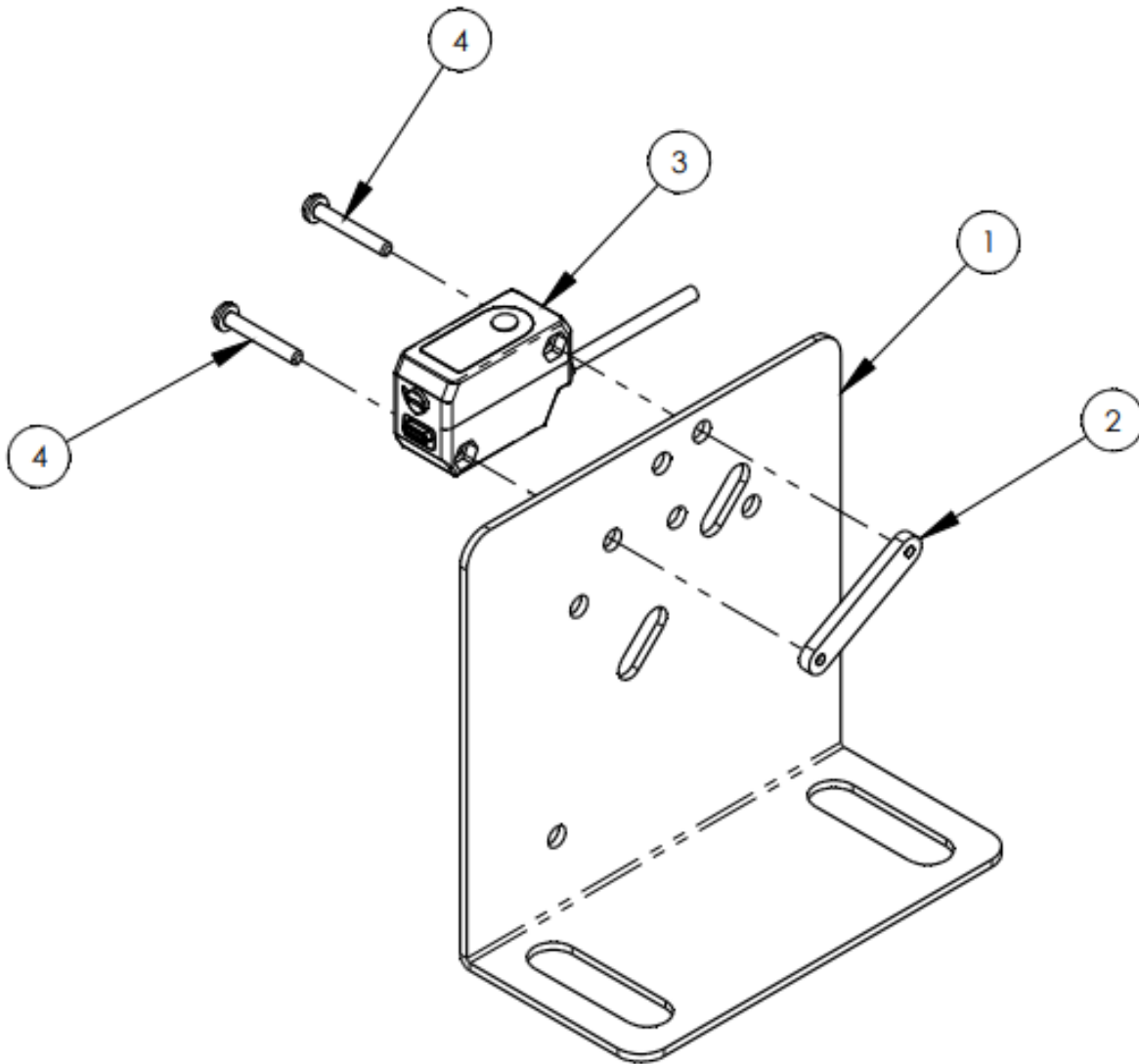

ITEM	QTY.	PART NUMBER	DESCRIPTION
1	1	1406947	BRKT,PROX EYE
2	1	1975-412E	PLATE,NUT,4-40X1.09 CTC
3	1	FFQS18VN6AFF	SENSOR,PROXIMITY
4	2	SSPS70048	4-40 X 3/4 PAN HD SLOTTED

14061280 Left Conveyor Assembly

AAC Drawing Number 14061280 Rev 0

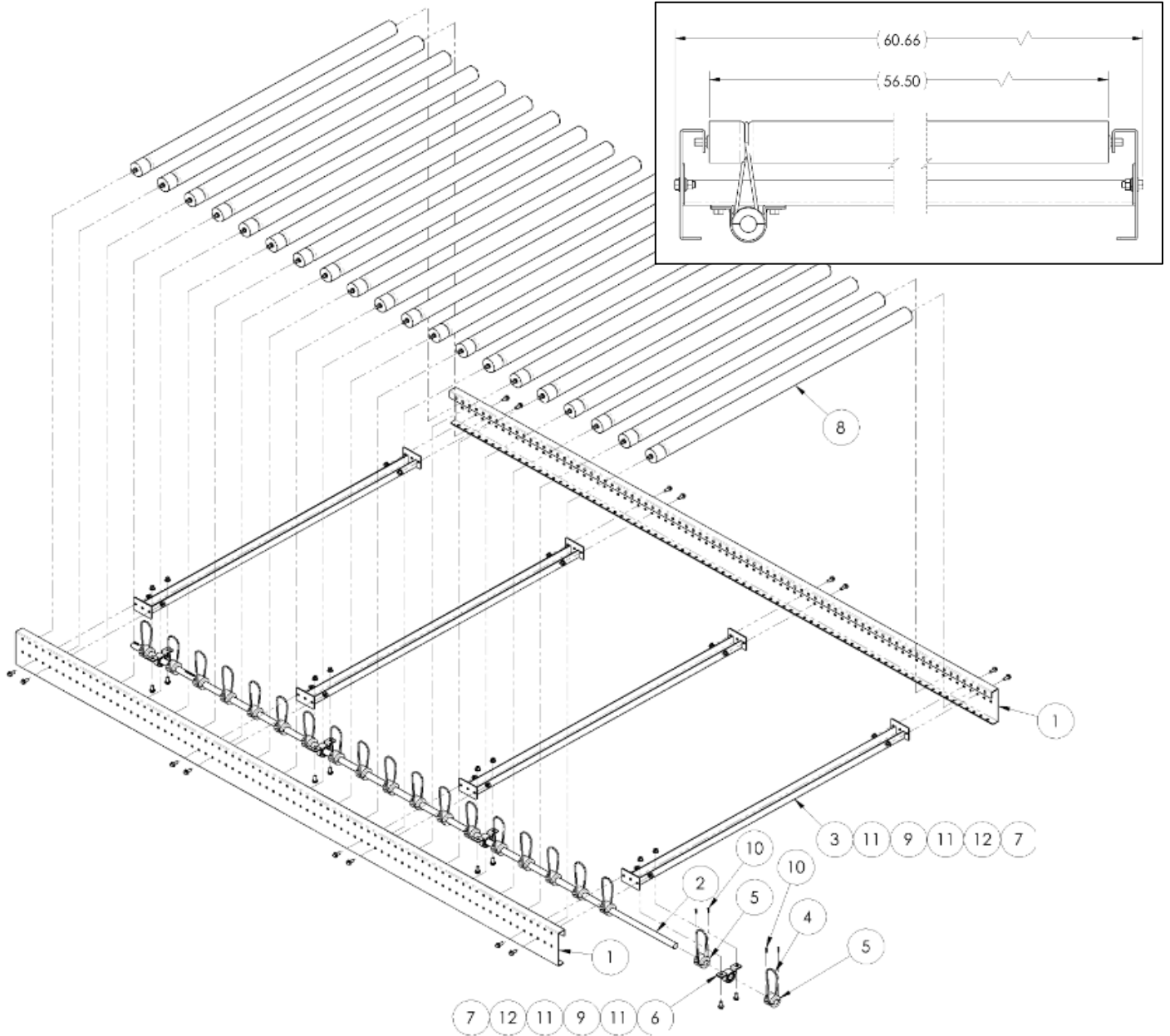

ITEM	QTY	PART NUMBER	DESCRIPTION
1	2	14061015	RAIL, SIDE, 10FT LONG
2	1	14061287	KEYED LINE SHAFT, 1" OD X120"L
3	4	14061293	CONVEYOR CROSS BRACE, 60"
4	20	440DB-3/16X13	BELTING RND, CONV, 3/16X13
5	20	440SPS	440 SPLIT SPOOL
6	4	BBPS251	BEARING, PILLOW BLOCK, 1"
7	24	NNH3/8-16	NUT,HEX,3/8-16
8	20	RM44060SG	ROLLER, 2.5"DIA, SNGL GRV
9	24	SSHHC25064	3/8-16 X 1,HEX CAP
10	40	SSZP#6056	SCR,PAN,SHT. METAL,#6X32
11	48	WWFS3/8	WASHER,FLAT,SAE,3/8
12	24	WWL3/8	WASHER,LOCK, 3/8

14061290 Right Conveyor Assembly

AAC Drawing Number 14061290 Rev 1

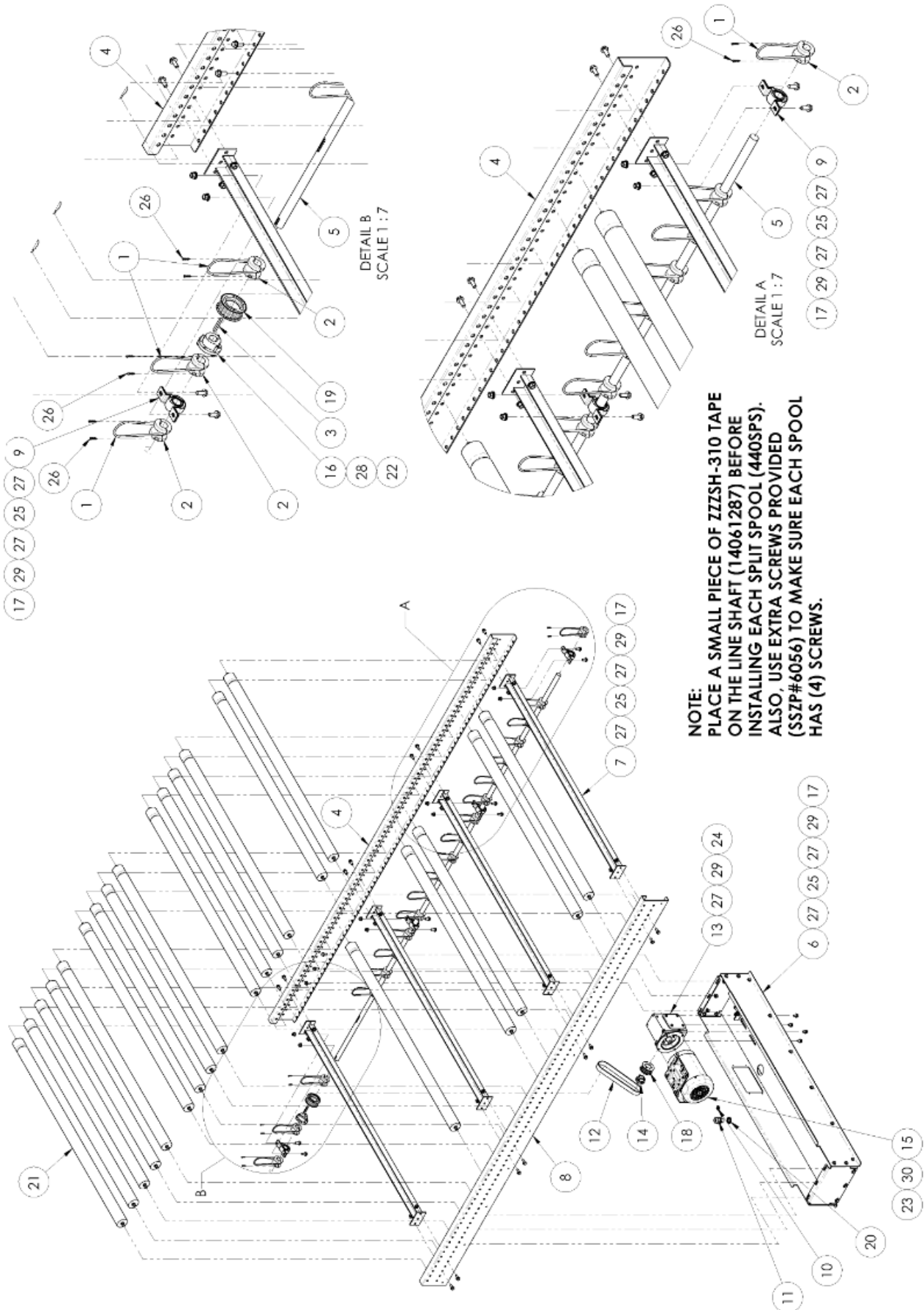

14061290 parts list

ITEM	QTY	PART NUMBER	DESCRIPTION
1	20	440DB-3/16X13	BELTING RND, CONV, 3/16X13
2	20	440SPS	440 SPLIT SPOOL
3	1	1332479	KEY,1/4 X 1/4 X 2.0L
4	1	14061015	RAIL, SIDE, 10FT LONG
5	1	14061287	KEYED LINE SHAFT, 1" OD X120"L
6	1	14061288	MOTOR CHANNEL ASSY
7	4	14061293	CONVEYOR CROSS BRACE, 60"
8	1	14061294	RAIL, SIDE, 10FT LONG
9	4	BBPS251	BEARING, PILLOW BLOCK, 1"
10	4	FF221-413	3 POS CONNECTOR, LEVERNUT
11	1	FF3460	STRAIN RELIEF,LIQ TIGHT, 3/4NPT
12	1	GG255H100	BELT, GEAR, 1/2P, 1"W, 51T, 25.5L
13	1	MMHDRF206-10/1-L-56CB	REDUCER, 10:1, 56C, LEFT 1' SHAFT
14	1	MMJA1	QD BUSHING,TAPER, 1"B, KEY, JA
15	1	MMNATE1-18-56CB	MOTOR, 1HP, 1728, 3 PH, C56,
16	1	MMSH1	QD BUSHING,TAPERED 1"B, 1/4 KEY, SH
17	30	NNH3/8-16	NUT,HEX,3/8-16
18	1	PP16H100JA	PULLEY,16T,1/2P,1"W,JA BUSHING
19	1	PP18H100SH	PULLEY,18T,1/2P,1"W,BUSHING BORE
20	1	RB8465	LOCK-NUT,NYLON,3/4NPT
21	20	RM44060SG	ROLLER, 2.5"DIA, SNGL GRV
22	3	SSHC01080	HEX HEAD 1/4-20 X 1-1/4
23	4	SSHC10056	5/16-18 X 7/8 HHCS
24	4	SSHC25048	3/8-16X3/4,HEX CAP
25	30	SSHC25064	3/8-16 X 1,HEX CAP
26	40	SSZP#6056	SCR,PAN,SHT. METAL,#6X32
27	64	WWFS3/8	WASHER,FLAT,SAE,3/8
28	3	WWL1/4	WASHER,LOCK, 1/4
29	34	WWL3/8	WASHER,LOCK, 3/8
30	4	WWL5/16	WASHER,LOCK, 5/16

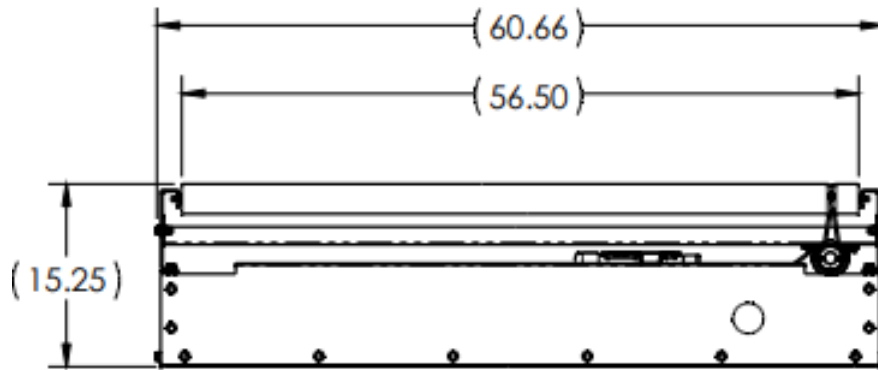

14061295 Solenoid, 4-Valve Assembly

AAC Drawing Number 14061295 Rev 1

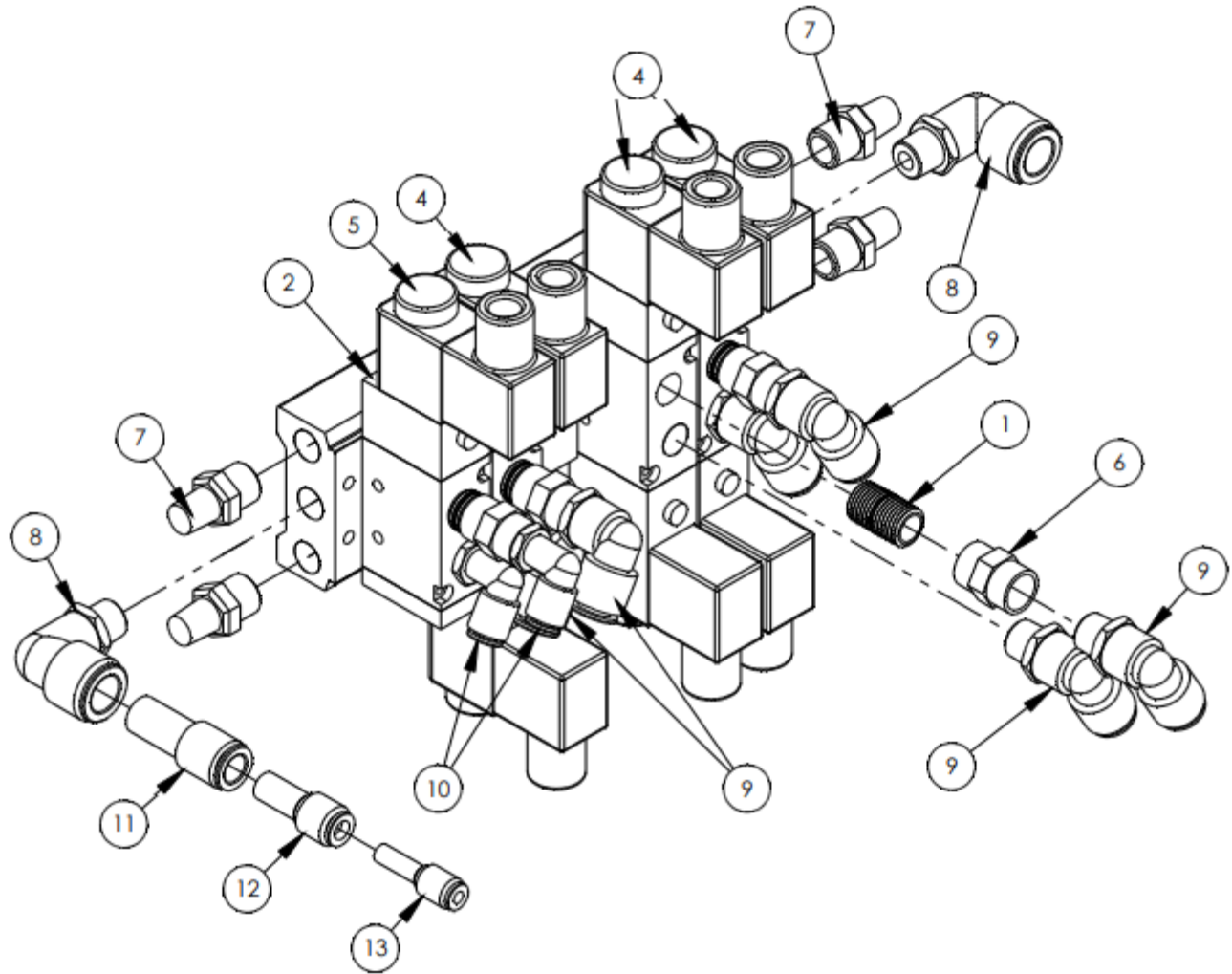

ITEM	QTY	PART NUMBER	DESCRIPTION
1	4	2156	FTG,GALV,NPPL,CLOSE,1/4
2	1	AAE4V200M6	MANIFOLD, 6 STATION
3	2	AAE4V200MB	MANIFOLD, BLANK PLATE
4	3	AAE4V230C08	VALVE, 1/4",24VDC,CNTR BK
5	1	AAE4V21008	VALVE, 1/4" PORTED, 24VDC
6	4	AAF207P-4	COUPLING,1/4 NPT,FEMALE
7	4	AAFP28	MUFFLER,1/4 NPT
8	2	AAQME-4-2S	FITTING,ELBOW,1/4NPT,1/2
9	6	AAQME-4-3S	FITTING,ELBOW,1/4NPT,3/8
10	2	AAQME-4-4	QU. MALE EL 1/4X1/4NPT
11	1	AAQPR-2-3	QUICK PLUG REDUCER
12	1	AAQPR-3-4	QUICK REDUCER 3/8-1/4
13	1	AAQPR-5-4	REDUCER, QUICK, 1/4- 5/32

14061300 Electrical Panel, Fold-in-half

AAC Drawing Number 14061300 Rev 1

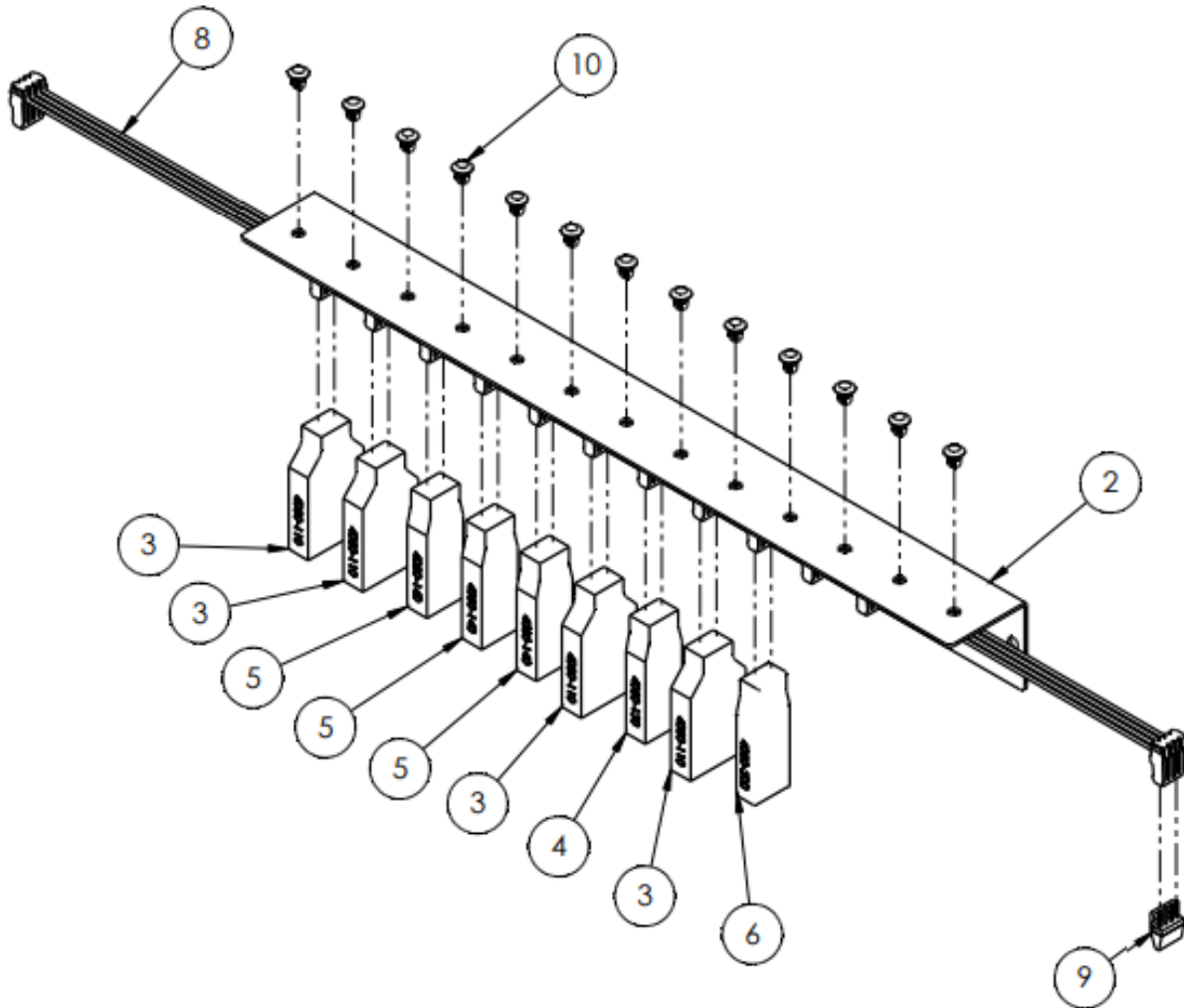

ITEM	QTY	PART NUMBER	DESCRIPTION
1	3*	12788-509	CABLE,JUMPER,OUTPUT
2	1	13061077	MTG BRKT, TWELVE MODULE STAT
3	4	4080-110	MODULE,QUAD INPUT
4	1	4080-130	MODULE,QUAD OPTO-ISO
5	3	4080-140	MODULE,QUAD OUTPUT
6	1	4080-200	MODULE,AIR PRESSURE
7	1*	4080-4191	CABLE,SBUS,#3,1330269
8	1	4080-4276	CABLE, SBUS ASSY, 14061500
9	1	4080-940	MODULE,TERMINATOR
10	13	ECPBMSH25C	MOUNT,CABLE TIE,NYLON

14061500-CAB Cable Kit

AAC Drawing Number 125866D Rev 2

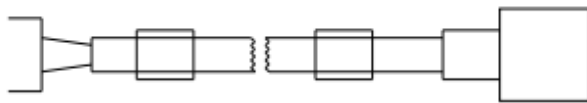

DWG - 125694D

PART NUMBER	LABEL TEXT
4080100-40	51.1 CENTERING GUIDE HOME
4080100-34	51.2 CENTERING GUIDE IN
4080100-40	51.3 FOLD ARM ROTATE HOME
4080100-34	51.4 FOLD ARM ROATE OUT
4080100-40	52.1 PUSHER TRANSFER HOME
4080100-34	52.2 PUSHER TRANSFER OUT
4080100-34	52.3 PUSHER PIVOT

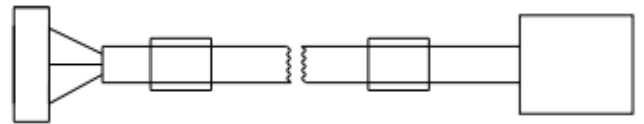

DWG - 125698D

PART NUMBER	LABEL TEXT
4080102-110	54.1 CONVEYOR MIDDLE EYE
4080102-180	54.2 CONVEYOR ENTRANCE EYE
4080102-110	54.3 CONVEYOR EXIT EYE

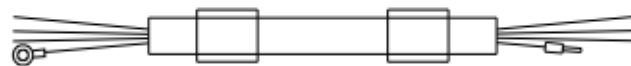

DWG - 125696D

PART NUMBER	LABEL TEXT
001101-305	CONVEYOR MOTOR

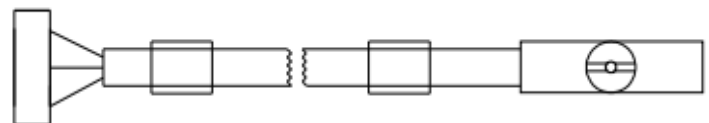

DWG - 125709D

PART NUMBER	LABEL TEXT
4080109-112	49.1 CENTERING GUIDE HOME PROX
4080109-112	49.2 CENTERING GUIDE MID PROX
4080109-127	49.3 CENTERING GUIDE IN PROX
4080109-90	50.1 FOLD ARM ROTATE HOME PROX
4080109-106	50.2 FOLD ARM ROTATE OUT PROX
4080109-181	50.3 PUSHER TRANSFER HOME PROX
4080109-106	50.4 PUSHER TRANSFER OUT PROX

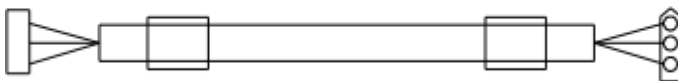

DWG - 125596C & 125600A

PART NUMBER	LABEL TEXT
4080-4208	56.1 LEFT LIGHT CURTAIN ASSY
4080-4208B	56.2 RIGHT LIGHT CURTAIN ASSY

1	12	CABLE, SBUS, 3P, 14FT	4080-4208B
1	11	CABLE, SBUS, 3P, 3.5FT	4080-4208
1	10	PROX ASSY,CYL,181"	4080109-181
1	9	PROX ASSY,CYL,127"	4080109-127
2	8	PROX ASSY,CYL,112"	4080109-112
2	7	PROX ASSY,CYL,106"	4080109-106
1	6	PROX ASSY,CYL,90"	4080109-90
1	5	CABLE ASSY,12MM,180"	4080102-180
2	4	CABLE ASSY,12MM,110"	4080102-110
3	3	CABLE ASSY,VALVE,40"	4080100-40
6	2	CABLE ASSY,VALVE,34"	4080100-34
1	1	CABLE ASSY,MOTOR,242"	001101-305
QTY. REQD.	ITEM NO.	DESCRIPTION	PART NO. STOCK SIZE

1406382 Cylinder Assembly

AAC Drawing Number 1406382 Rev 2

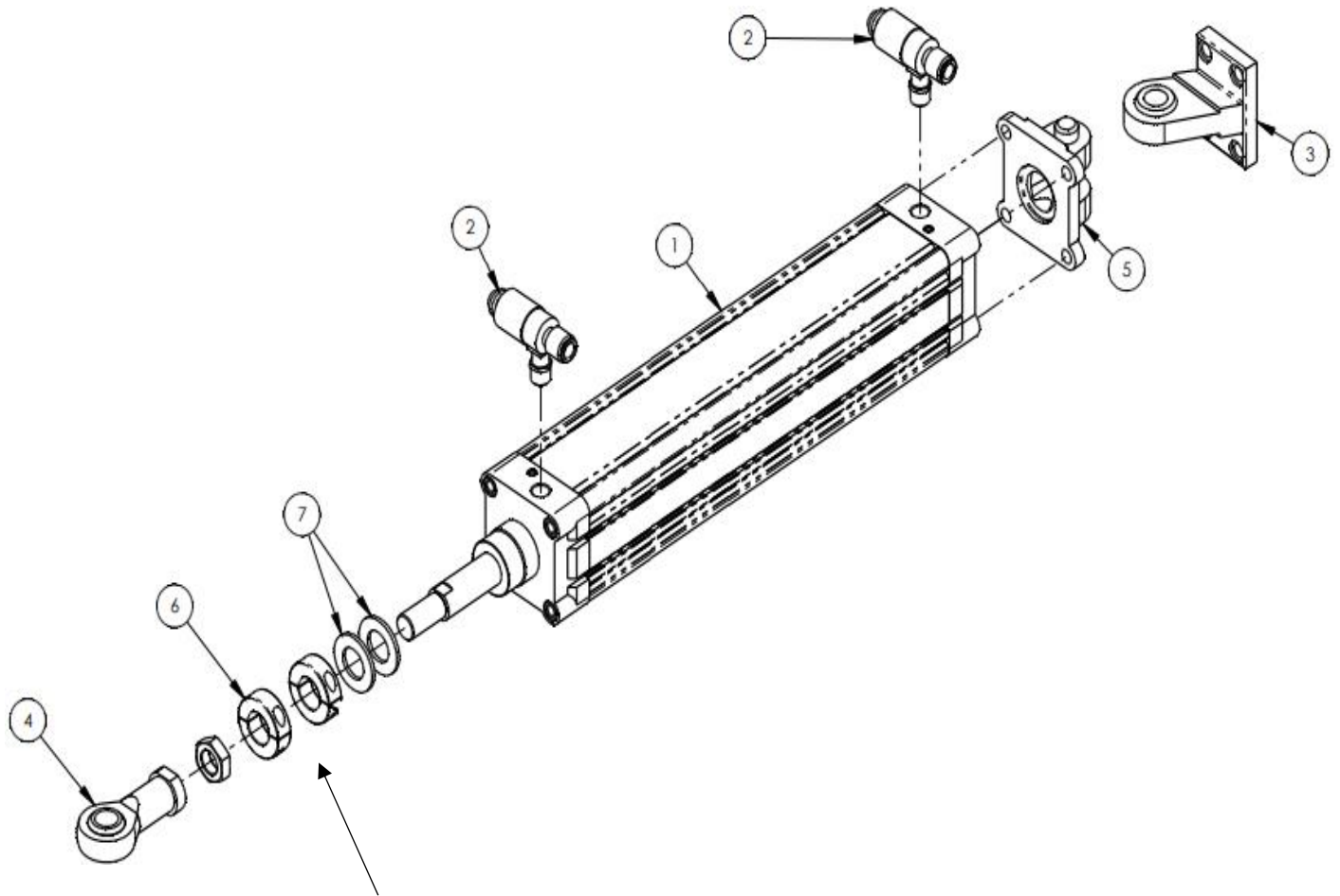

EXTEND CYL 1.5" AND ADD COLLARS AND URETHANE WASHERS

ITEM	QTY.	PART NUMBER	DESCRIPTION
1	1	AACDNCB80710PPV	CYL, AIR, MM, 80B X 710S
2	2	AAFASV510F3R	QUICK EXHAUST,3/8R,3/8T
3	1	AAFLSNG80	PIVOT MOUNT, 80MM CYL
4	1	AAFSGSM20x15	ROD END, FEM-20MM X 1.5MM
5	1	AAFSNC80	REAR PIVOT
6	2	CCCLMSP25F	COLLAR, CLAMP,SPLIT,25MM
7	2	WWU25MM	WASHER,URETHANE,25MM ID

1406545 Push Plate Assembly

AAC Drawing Number 1406545 Rev 0

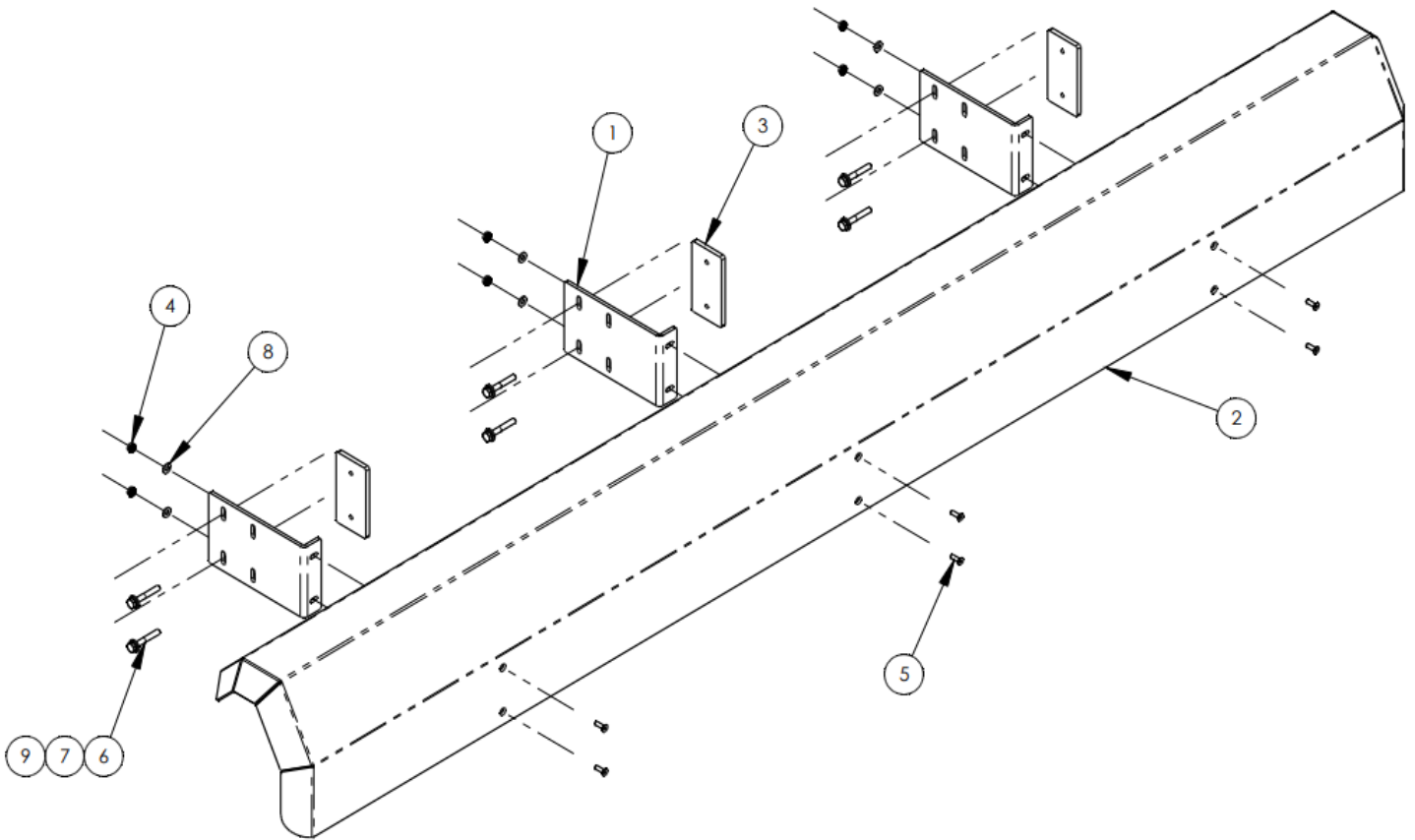

ITEM	QTY	PART NUMBER	DESCRIPTION
1	3	1406540	PUSH PLATE MOUNT
2	1	1406541	PUSH PLATE
3	3	1406542	NUT PLATE, 1/4-20 X 2.5CTC
4	6	NNK10-32	KEP NUT, 10-32
5	6	SSFC98040	#10-32 X 5/8 FLAT ALLEN
6	6	SSHC01112	1/4-20 X 1-3/4 HHCS
7	6	WWFS1/4	WASHER, FLAT, SAE, 1/4
8	6	WWFS10	WASHER, FLAT, #10, SAE
9	6	WWL1/4	WASHER, LOCK, 1/4

1306F-WD1 Wiring Diagram. Control Box, Power

AAC Drawing Number 125969D Rev 0

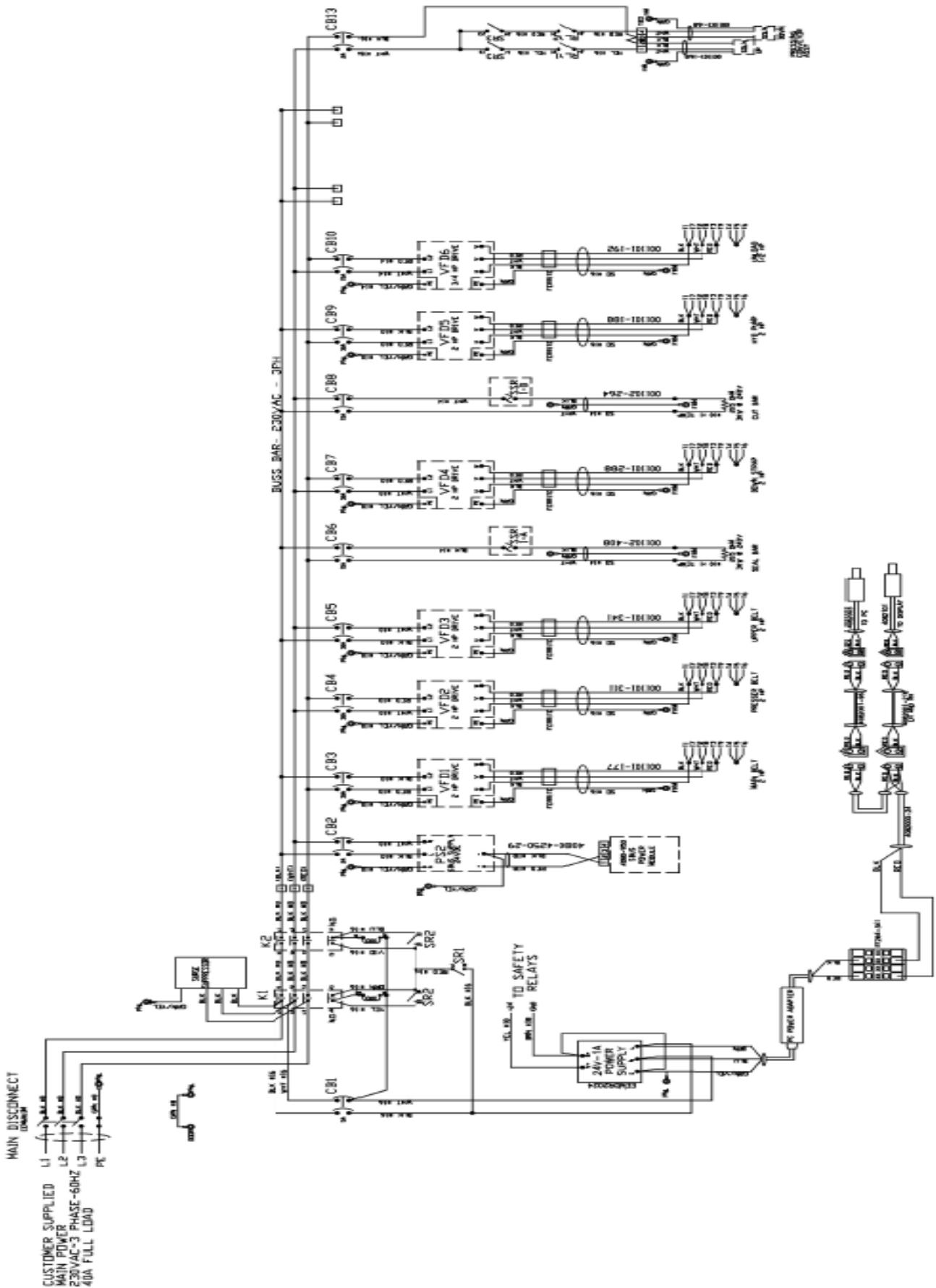

1306F-WD4 Wiring Diagram, Safety Circuit

AAC Drawing Number 125162E Rev 0

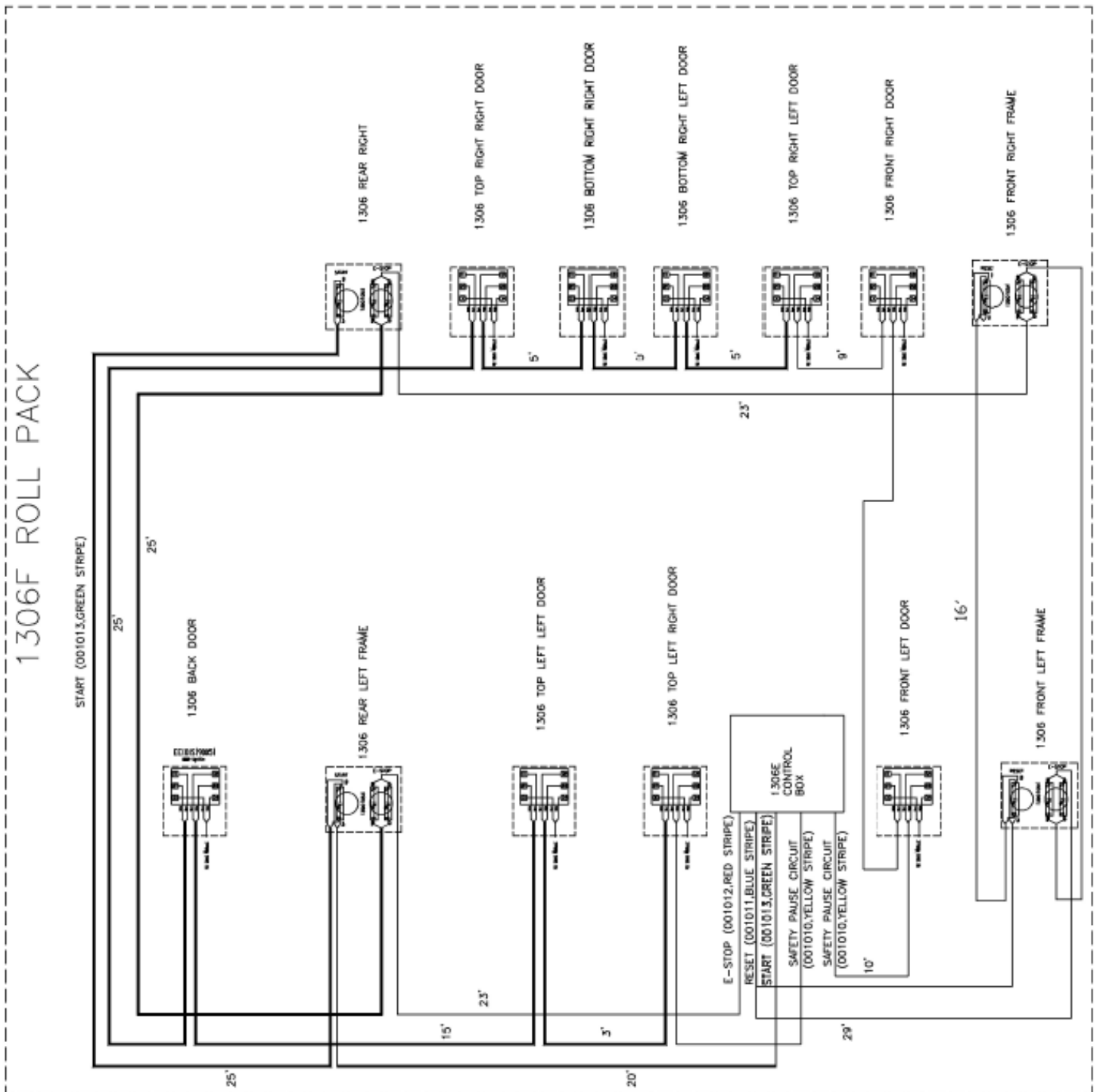

1306D-PD Pneumatic Diagram

AAC Drawing Number 125650D Rev 0

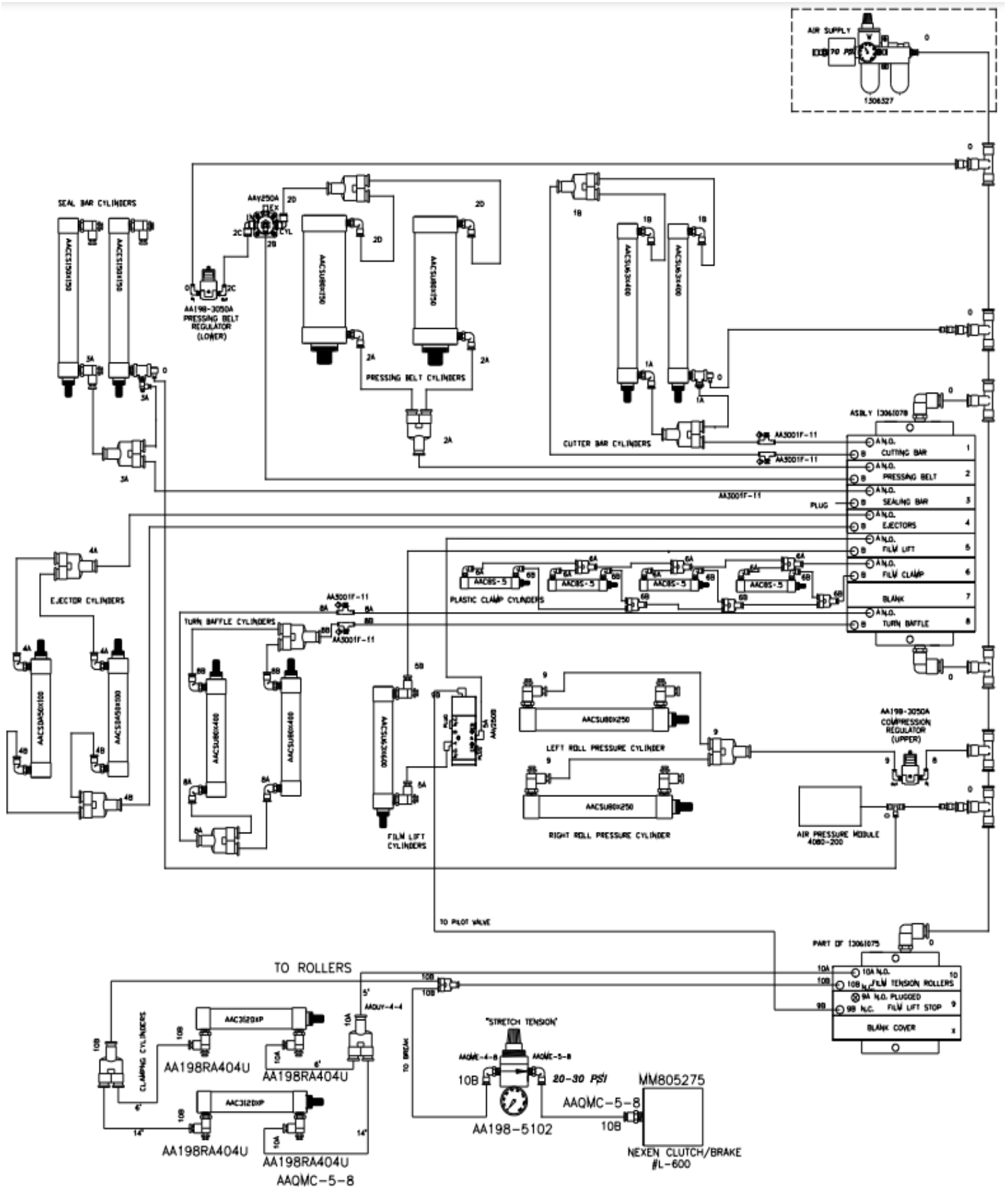

1306-PD3 Pneumatic Diagram

AAC Drawing Number 125562D Rev 0

See new version 1306D-PD drawing

5. TRAINING

Check	Description	Time Hrs.
	Safety Instructions	0.5
	Installation <ul style="list-style-type: none"> • Set up • Power On cycle 	1.5
	Operation <ul style="list-style-type: none"> • Individual components • Serial Bus operator label • Operation Description • With / without dustcover • Maintenance Operator Label 	3
	Service <ul style="list-style-type: none"> • Lock out tag out • Operation sequence Mechanical level 	1
	Mechanical Adjustments <ul style="list-style-type: none"> • Table Adjustments • Tension wheel • Clamp fingers • Staplers 	3
	Pneumatic components <ul style="list-style-type: none"> • Plumbing diagram • FRL unit • Solenoid valve manifold • Pressure adjustments • Pressure switch 	1.5
	Electric component <ul style="list-style-type: none"> • Wiring diagram • Photoelectric Sensor 	1.5
	Serial Bus <ul style="list-style-type: none"> • Touch screen • Modules • Program update • Technical screens 	2
	Maintenance Technical Level	1
	Troubleshooting	0.5
	Evaluate any questions.	0.5

Participants: _____

Instructor: _____ Date: _____

Atlanta Attachment Company (AAC) Statement of Warranty

Manufactured Products

Atlanta Attachment Company warrants manufactured products to be free from defects in material and workmanship for a period of eight hundred (800) hours of operation or one hundred (100) days whichever comes first. Atlanta Attachment Company warrants all electrical components of the Serial Bus System to be free from defects in material or workmanship for a period of thirty-six (36) months.

Terms and Conditions:

- AAC Limited Warranty becomes effective on the date of shipment.
- AAC Warranty claims may be made by telephone, letter, fax or e-mail. All verbal claims must be confirmed in writing.
- AAC reserves the right to require the return of all claimed defective parts with a completed warranty claim form.
- AAC will, at its option, repair or replace the defective machine and parts upon return to AAC.
- AAC reserves the right to make the final decision on all warranty coverage questions.
- AAC warranty periods as stated are for eight hundred (800) hours or one hundred (100) days whichever comes first.
- AAC guarantees satisfactory operation of the machines based on generally accepted industry standards, contingent upon proper application, installation, and maintenance.
- AAC Limited Warranty may not be changed or modified and is not subject to any other warranty expressed or implied by any other agent, dealer, or distributor unless approved in writing by AAC in advance of any claim being filed.

What Is Covered

- Electrical components that are not included within the Serial Bus System that fail due to defects in material or workmanship, which are manufactured by AAC are covered for a period of eight hundred (800) hours.
- Mechanical parts or components that fail due to defects in material or workmanship, which are manufactured by AAC.
- Purchased items (sewing heads, motors, etc.) will be covered by the manufacturers (OEM) warranty.
- AAC will assist in the procurement and handling of the manufacturers (OEM) claim.

What Is Not Covered

- Parts that fail due to improper usage, lack of proper maintenance, lubrication and/or modification.
- Damages caused by; improper freight handling, accidents, fire, and issues resulting from unauthorized service and/or personnel, improper electrical, plumbing connections.
- Normal wear of machine and parts such as Conveyor belts, "O" rings, gauge parts, cutters, needles, etc.
- Machine adjustments related to sewing applications and/or general machine operation.
- Charges for field service.
- Loss of time, potential revenue, and/or profits.
- Personal injury and/or property damage resulting from the operation of this equipment.

Declaración de Garantía

Productos Manufacturados

Atlanta Attachment Company garantiza que los productos de fabricación son libres de defectos de material y de mano de obra durante un periodo de ochocientos (800) horas de operación o cien (100) días cual llegue primero. Atlanta Attachment Company garantiza que todos los componentes del Serial bus son libres de defectos de material y de mano de obra durante un periodo de treinta y seis (36) meses.

Términos y Condiciones:

- La Garantía Limitada de AAC entra en efecto el día de transporte.
- Reclamos de la Garantía de AAC pueden ser realizados por teléfono, carta, fax o correo electrónico. Todo reclamo verbal tiene que ser confirmado vía escrito.
- AAC reserva el derecho para exigir el retorno de cada pieza defectuosa con un formulario de reclamo de garantía.
- AAC va, según su criterio, reparar o reemplazar las máquinas o piezas defectuosas devueltas para AAC.
- AAC reserva el derecho para tomar la decisión final sobre toda cuestión de garantía.
- Las garantías de AAC tiene una validez de ochocientas (800) horas o cien (100) días cual llega primero.
- AAC garantiza la operación satisfactoria de sus máquinas en base de las normas aceptadas de la industria siempre y cuando se instale use y mantenga de forma apropiada.
- La garantía de AAC no puede ser cambiado o modificado y no está sujeto a cualquier otra garantía implicado por otro agente o distribuidor menos al menos que sea autorizado por AAC antes de cualquier reclamo.

Lo Que Está Garantizado

- Componentes eléctricos que no están incluidos dentro del sistema Serial Bus que fallen por defectos de materiales o de fabricación que han sido manufacturados por AAC son garantizados por un periodo de ochocientas (800) horas.
- Componentes mecánicos que fallen por defectos de materiales o de fabricación que han sido manufacturados por AAC son garantizados por un periodo de ochocientas (800) horas.
- Componentes comprados (Motores, Cabezales,) son protegidos debajo de la garantía del fabricante.
- AAC asistirá con el manejo de todo reclamo de garantía bajo la garantía del fabricante.

Lo Que No Está Garantizado

- Falla de repuestos a la raíz de uso incorrecto, falta de mantenimiento, lubricación o modificación.
- Daños ocurridos a raíz de mal transporte, accidentes, incendios o cualquier daño como resultado de servicio por personas no autorizados o instalaciones incorrectas de conexiones eléctricas o neumáticas.
- Desgaste normal de piezas como correas, anillos de goma, cuchillas, agujas, etc.
- Ajustes de la máquina en relación con las aplicaciones de costura y/o la operación en general de la máquina.
- Gastos de Reparaciones fuera de las instalaciones de AAC
- Pérdida de tiempo, ingresos potenciales, y/o ganancias.
- Daños personales y/o daños a la propiedad como resultado de la operación de este equipo.



6. INDEX

A

Access Code, 40
Advanced Functions, 42
Advanced Manual Information, 27
Advanced Settings, 40
All Settings Page, 27

C

Compensation, 29
Components, 20

E

Electrical, 3, 6, 9, 58
Error Messages, 60

F

Film Loading, 21
First Aid, 5

G

General Instructions, 40
General Operation, 40

I

INDEX, 156
INSTALLATION, 11

L

Lockout/Tagout Program, 19

M

Machine Layout, 16
Machine Operation, 39
Machine Safety, 17
Machine Screens, 23
Machine Sequence, 33
Machine Set-up, 21
Machine Specifications, 13

Atlanta Attachment Company 362 Industrial Park Drive, Lawrenceville, GA 30046 E-mail: Sales@atlatt.com Phone: +1 (770) 9637369

Machine Start Up, 39
[Main Air pressure](#), 57
Main Screen, 41
Maintenance, 8, 49
Mechanical, 56
Mechanical Adjustments, 153

N

Notes, 157

O

OPERATION, 20
Options, 14

P

Parts Lists, 62
[Patents & Patents Pending](#), 0
Pneumatic, 3, 6, 9
Pneumatic Cycle, 29
Pneumatic System, 57
Preventative Maintenance Charts, 49

R

Resetting Piece Count, 26
Run Modes, 32

S

Safety Instruction, 3
Seal Bar Temperature Settings, 27
Security Information, 26
SERVICE, 56
Set Up, 15
Standard Modules, 59
Style Editing, 43
Styles, 23
System Information, 26

T

TRAINING, 153
Troubleshooting, 60



U

Unload Direction, 32
Utility Hookups, 12

V

VFD Drive Setup, 30

VFD Motor Drive Parameters, 56
VFD Motor Drives, 56

W

Warning, 18
Warranty, 154

7. Notes:





Atlanta Attachment Company Inc.
362 Industrial Park Drive
Lawrenceville, GA 30046
Phone: +1 (770) 963-7369
www.atlatt.com

Printed in USA
Digital Version of this Manual Available at:
http://atlatt.com/tech_manuals.php

Atlanta Attachment Company 362 Industrial Park Drive, Lawrenceville, GA 30046 E-mail: Sales@atlatt.com Phone: +1 (770) 9637369