

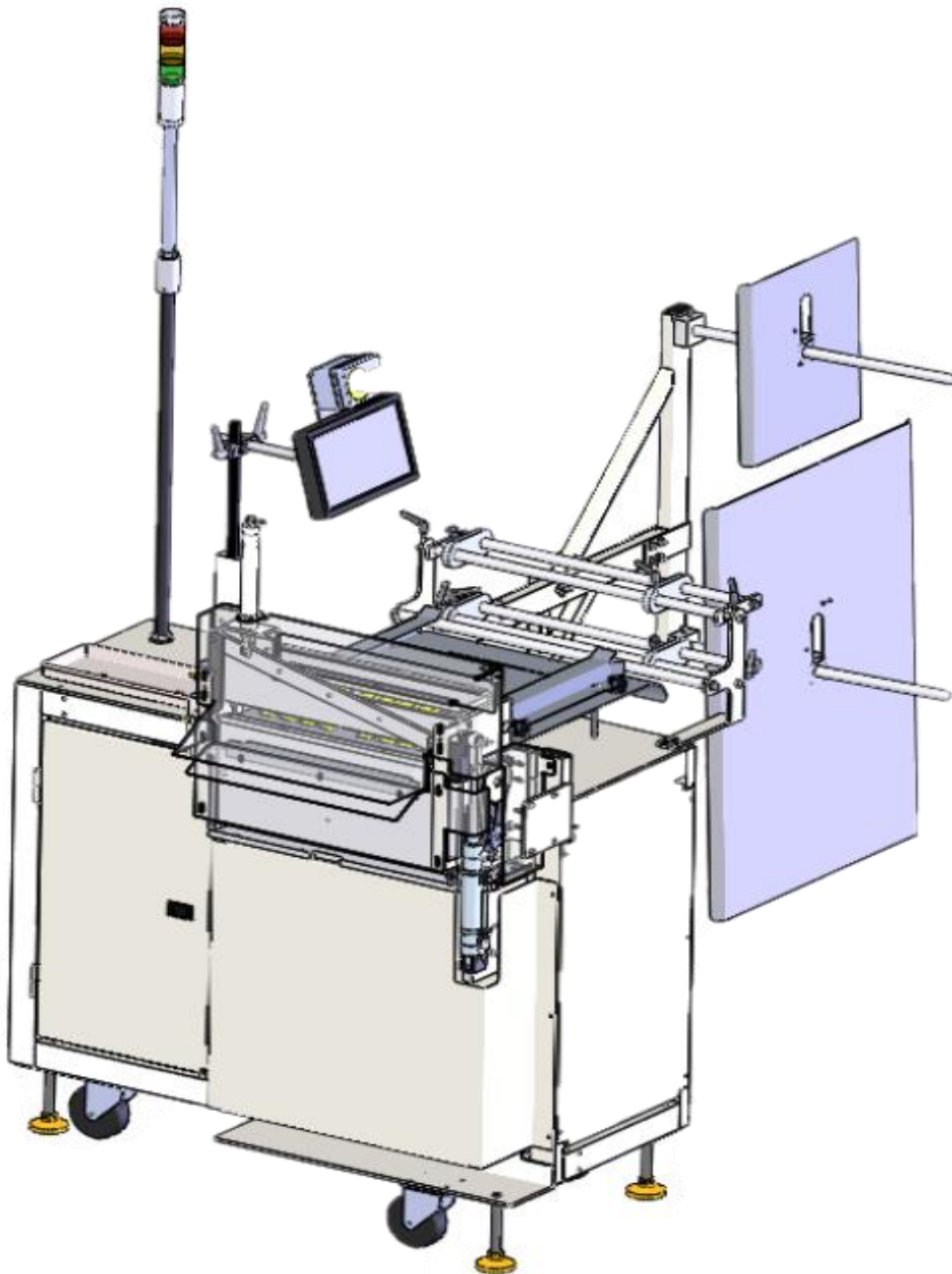

Model **3200PB1E**

Revision 1 May 4, 2023

# Technical Manual & Parts Lists



**Atlanta Attachment Company**

362 Industrial Park Drive

Lawrenceville, GA 30046

770-963-7369 • [www.atlatt.com](http://www.atlatt.com)

# ATLANTA ATTACHMENT COMPANY, INC.

## Confidential and Proprietary Information

The materials contained herein are confidential and proprietary information of Atlanta Attachment Company. In addition to any confidentiality and non-disclosure obligations that currently exist between you and Atlanta Attachment Company, your use of these materials serves as an acknowledgment of the confidential and proprietary nature of these materials and your duty not to make any unauthorized use or disclosure of these materials.

All materials contained herein are additionally protected by United States Copyright law and may not be used, disclosed, reproduced, distributed, published or sold without the express written consent of Atlanta Attachment Company, which consent may be withheld in Atlanta Attachment Company's sole discretion. You may not alter or remove any copyright, trademark or other notice from copies of these materials.

## Patents & Patents Pending

The sale of this product does not sell or otherwise transfer any license or other rights under any U.S. Patent or other corresponding foreign patent.

This equipment is manufactured under one or more of the following patents:

4,280,421 • 4,432,294 • 4,466,367 • 4,644,883 • 5,134,947 • 5,159,889 • 5,203,270 • 5,373,798 • 5,437,238 • 5,522,332 • 5,524,563 • 5,562,060 • 5,634,418 • 5,647,293 • 5,657,711 • 5,743,202 • 5,865,135 • 5,899,159 • 5,915,319 • 5,918,560 • 5,924,376 • 5,979,345 • 6,035,794 • 6,055,921 • 6,202,579 • 6,279,869 • 6,295,481 • 6,494,225 • 6,523,488 • 6,574,815 • 6,802,271 • 6,834,603 • 6,968,794 • 6,994,043 • 7,543,364 • 7,574,788 • 7,647,876 • 7,735,439

Foreign Patents: 9-520,472 • 0,537,323 • 92,905,522.6 • 96,936,922.2 • 2,076,379 • 2,084,055  
Other U.S. and Foreign Patents Pending.

## IMPORTANT

**It is important to read and understand the information contained within this manual before attempting to operate the machine. Atlanta Attachment Co., Inc. shall not be held liable for damage resulting from misuse of the information presented within, and reserves the right to change the information contained within, without prior notification.**

# Contents

Important Safety Instruction .....	0
Liability .....	1
Safety Equipment on the Machines .....	2
Protective Eyewear .....	3
Important Notices.....	4
Maintenance .....	6
Repair .....	7
A Word to the End User.....	8
Safety Precautions.....	8
General Machine Data .....	9
Electrical / Pneumatic Setup .....	9
Initial Machine Setup.....	9
Component Identification .....	10
Touch Screen Operation .....	11
Light Tower Function .....	11
Machine Operation.....	12
Initial Border Loading Procedure .....	12
Border Splicing Method.....	12
Setup Screen Information .....	13
Styles.....	14
Factory Pre-set Machine Adjustments .....	18
Operational Path of Screens.....	19
3200PB1E Main Feed Motor, Parameter Setting .....	25
Machine Maintenance .....	26
Electric Eye Sensor Adjustment .....	26
Reflective Tape Maintenance .....	26
Assembly Drawings & Parts Lists .....	27
33200PB1E. Border Workstation, Measure & Cut.....	28
32003000PA1 Main Frame Assembly .....	30
32004000PB1 Guillotine Assembly .....	32
32007700P Roll Holder Assembly .....	34
3200213 Control System.....	35
3200PB1E-PD1 Pneumatic Diagram.....	37
3200PB1E-WD1 Wiring Diagram, Control Panel.....	38

---



# Important Safety Instruction



This part of the Instruction Material is provided for the safe use of your equipment. It contains important information to help work safely with the unit and describes the dangers inherent in machinery. Some of these dangers are obvious, while others are less evident.

## Mandatory Information

All persons operating and/or working on the 3200PB1E, Mattress Border Workstation, should read and understand all parts of the Safety Instructions. This applies, in particular, for persons who only operate and/or work on the unit occasionally (e.g. for maintenance and repair). Persons who have difficulty reading must receive particularly thorough instruction.

## Scope of the Instruction Material

- The Instruction Material comprises:
- Safety information
- Operator Instructions
- Electrical and Pneumatic diagrams

And may also include.

- A list of recommended spare parts
- Instruction Manual(s) for components made by other manufacturers.
- The layout and installation diagram containing information for installation.

## Intended Use

Our machines are designed and built in line with the state of the art and the accepted safety rules. However, all machines may endanger the life and limb of their users and/or third parties and be damaged or cause damage to other property, particularly if they are operated incorrectly or used for purposes other than those specified in the Instruction Manual.

## Exclusion of Misuse



Non-conforming uses include, for example, using the equipment for something other than it was designed for, as well as operation without duly installed safety equipment. The risk rests exclusively with the end user.

Conforming use of the machine includes compliance with the technical data, information, and regulations in all parts of the complete Instruction Material, as well as compliance with the maintenance regulations. All local safety and accident prevention regulations must also be observed.

## Liability

The machine should only be operated when in perfect working order, with due regard for safety and the potential dangers, as well as in accordance with the Instruction Material. Faults and malfunctions capable of impairing safety should be remedied immediately. We cannot accept any liability for personal injury or property damage due to operator errors or non-compliance with the safety instructions contained in this booklet. The risk rests exclusively with the end user.

The Instruction Material should always be kept near the machine so that it is accessible to all concerned.

The local, general, statutory, and other binding regulations on accident prevention and environmental protection must also be observed in addition to the Instruction Material. The operating staff must be instructed accordingly. This obligation also includes the handling of dangerous substances and provision/use of personal protective equipment.

The Instruction Material should be supplemented by instructions, including supervisory and notification duties with due regard for special operational features, such as the organization of work, work sequences, the personnel deployed, etc.

The personnel's awareness of the dangers and compliance with the safety regulations should be checked at irregular intervals.

## Choice and Qualification of Personnel

Ensure that work on the machine is only carried out by reliable persons who have been appropriately trained for such work - either within the company, by our field staff or at our office - and who have not only been duly appointed and authorized but are also fully familiar with the local regulations. Work on the machine should only be carried out by skilled personnel, under the management and supervision of a duly qualified engineer.

This not only applies when the machine is used for production, but also for special work associated with its operation (start-up and maintenance), especially when it concerns work on the hydraulic or electrical systems, as well as on the software/serial bus system.

## Training

Everyone working on or with the machine should be duly trained and informed about correct use of the safety equipment, the foreseeable dangers which may arise during operation of the machine and the safety precautions to be taken. In addition, the personnel should be instructed to check all safety mechanisms at regular intervals.

## Responsibilities

Clearly define exactly who is responsible for operating, setting-up, servicing and repairing the machine. Define the responsibilities of the machine operator and authorize him to refuse any instructions by third parties if they run contrary to the machine's safety. This applies for the operators of machines linked to other equipment. Persons receiving training of any kind may only work on or with the machine under the constant supervision of an experienced operator. Note the minimum age limits permitted by law.

## A Word to the Operator

The greatest danger inherent in our machines: is that of fingers, hands or loose clothing being drawn into a machine by live, coasting or rotating tools or assemblies or of being cut by sharp tools or burned by hot elements.

### **ALWAYS BE CONSCIOUS OF THESE DANGERS!**

## Safety Equipment on the Machines



All machines are delivered with safety equipment, which shall not be removed or bypassed during operation.

The correct functioning of safety equipment on machines and systems should be checked every day and before every new shift starts, after maintenance and repair work, when starting up for the first time and when restarting (e.g. after prolonged shutdowns).

If safety equipment must be dismantled for setting-up, maintenance or repair work, such safety equipment shall be replaced and checked immediately upon completing the maintenance or repair work. All protective mechanisms shall be fitted and fully operational whenever the machine is at a standstill or if it has been shut down for a longer period.

## Damage

If any changes capable of impairing safety are observed in the machine or its mode of operation, such as malfunctions, faults or changes in the machine or tools, appropriate steps must be taken immediately, the machine switched off and a proper lockout tagout procedure followed. The machine should be examined for obvious damage and defects at least once per shift. Damage found shall be immediately remedied by a duly authorized person before resuming operation of machine.

The machine should only be operated when in perfect working order and when all protective mechanisms and safety equipment, such as detachable protective mechanisms, emergency STOP systems, etc. are in place and operational.

## Faults or Errors

The machine must be switched off and all moving or rotating parts allowed to come to a standstill and secured against accidental restart before starting to remedy any faults or errors.

## Signs on the Machine

Safety and danger signs on the machine should be observed and checked at regular intervals to ensure that they are complete and undamaged. They should be clearly displayed, visible to everyone and legible at all times.

### Clothing, Jewelry, Protective Equipment

Long loose hair, loose-fitting clothes, gloves, and jewelry, including rings, should be avoided to avoid injuries due to being caught, drawn in and wound up inside the machine.

## Protective Eyewear

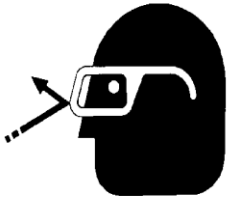

Protective eyewear that has been tested by the local authorities should be worn whenever there is a possibility of loose or flying objects or particles such as when cleaning the machine with compressed air.

## Tools

Always count the number of tools in your possession before starting work on the machine. This will allow you to check that no tools have been left behind inside the machine. Never leave a tool in the machine while working.

## Oils, Lubricants, Chemicals

Note the applicable safety regulations for the product used.

## No Smoking, Fire, Explosion Hazard

Smoking and open flame (e.g. welding work) should be prohibited in the production area due to the risk of fire and explosions.

## Workplace

A clear working area without any obstructions whatsoever is essential for safe operation of the machine. The floor should be level and clean, without any waste.

The workplace should be well lit, either by the general lighting or by local lights.

## Emergency STOP

The emergency STOP buttons bring all machine movements to a standstill. Make sure you know exactly where they are located and how they work. Try them out. Always ensure easy access to the nearest emergency STOP button while working on the machine.

## First Aid

1. Keep calm even when injured.
2. Clear the operator from the danger zone. The decision of what to do and whether to seek additional assistance rests entirely with you, particularly if someone has been trapped.
3. Give First Aid. Special courses are offered by such organizations as the employers' liability insurance association. Your colleagues should be able to rely on you and vice versa.
4. Call an ambulance. Do you know the telephone numbers for the ambulance service, police, and fire service?

## Important Notices

### Reporting and Fighting Fires

Read the instructions posted in the factory about reporting fires and the emergency exits. Make sure you know exactly where the fire extinguishers and sprinkler systems are located and how they are operated. Pass on the corresponding information to the firemen when they arrive. Ensure there are enough signs to avoid fire hazards.

The following fire extinguishers may be used:

- Dry powder extinguishers, ABC fire-extinguishing powder.
- Carbon dioxide fire extinguishers to DIN 14461 for electronic components. Great care must be exercised when using carbon dioxide fire extinguishers in confined, badly ventilated rooms (see DIN 14406 and 14270).

Isolate the machine from the power supply if a fire breaks out. Do not use water on burning electrical parts until it is certain that they have been completely disconnected from the power supply. Burning oils, lubricants, plastics, and coatings on the machine can give off gases and vapors that may be harmful to your health.

A qualified person should be consulted to repair the damage after a fire.

### Electrical Power Supply



Before undertaking any maintenance or repair work on the machine, switch off the electrical power to the machine at the main source and secure it with a padlock so that it cannot be switched on again without authorization.

In practice, this may mean that the technician, electrician, and operator all attach their own padlock to the master switch simultaneously so that they can carry out their work safely. Locking extension plates should be available for multiple locks if required. The primary purpose for a lockout/tagout procedure is to protect workers from injury caused by unexpected energizing or start-up of equipment.

Energy sources (electrical/pneumatic/hydraulic, etc.) for the equipment shall be turned off or disconnected and the switches locked or labeled with a warning tag. It is the responsibility of the employer to establish control procedures. Follow lockout/tagout procedures before, setup and/or any service or maintenance work is performed, including lubrication, cleaning, or clearance of jams.

**Caution: The machine is still not completely de-energized even when the master switch is off.**

- Electricity - The machine is always isolated from the electrical power supply whenever the master switch has been switched off. However, this does not apply for the power supply in the control cabinet, nor for equipment that does not draw its power via the master switch.
- Pneumatic / hydraulic energy - Almost all our machines carry compressed air. In addition to switching off the master switch, the air supply must also be disconnected, and the machine checked to ensure it is depressurized before starting any work on the machine; otherwise, the machine may execute uncontrolled movements.

- Kinetic energy - Note that some motors or spindles, for example, may continue to run or coast run on after being switched off.
- Potential energy - Individual assemblies may need to be secured if necessary for repair work.

## Delivery of the Machine/Packaging

Note any markings on the packaging, such as weights, lifting points and special information. Avoid temperature fluctuations. Condensation may damage the machine.

## Transport Damage

The packaging and machine must immediately be examined for signs of damage in transit. Such damage must be reported to the shipper/transporter within the applicable time limits. Contact Atlanta Attachment Company and/or your transport insurer immediately, if signs of damage are visible. Never operate a damaged machine.

## Interim Storage

If the machine must be stored temporarily, it must be oiled or greased and stored in a dry place where it is protected from the weather to avoid damage. A corrosion-inhibiting coating should be applied if the machine must be stored for a longer period and additional precautions taken to avoid corrosion.

## Transporting the Machine

Disconnect the machine from all external connections and secure any loose assemblies or parts. Never step under a suspended load. When transporting the machine or assemblies in a crate, ensure that the ropes or arms of a forklift truck are positioned as close to the edge of the crate as possible. The center of gravity is not necessarily in the middle of the crate. Note the accident prevention regulations, safety instructions and local regulations governing transport of the machine and its assemblies.

Only use suitable transport vehicles, hoisting gear and load suspension devices that are in perfect working order and of adequate carrying capacity. Transport should only be entrusted to duly qualified personnel.

Never allow the straps to rest against the machine enclosure and never push or pull sensitive parts of the machine. Ensure that the load is always properly secured. Before or immediately after loading the machine, secure it properly and affix corresponding warnings.

All transport guards and lifting devices must be removed before the machine is started up again. Any parts that are to be removed for transport must be carefully refitted and secured before the machine is started up again.

## Workplace Environment

Our machines are designed for use in enclosed rooms: Permissible ambient temperature approx. 5 - 40 °C (40 - 104 °F). Malfunctions of the control systems and uncontrolled machine movements may occur at temperatures outside this range.

Protect against climatic influences, such as electrostatic charges, lightning strikes, hail, storm damage, high humidity, salinity of the air in coastal regions.

Protect against influences from the surroundings: no structure-borne vibrations, no grinding dust, or chemical vapors.

Protect against unauthorized access.

Ensure that the machine and accessories are set up in a stable position.

Ensure easy access for operation and maintenance (Instruction Manual and layout diagram); also verify that the floor is strong enough to carry the weight of the machine.

## Local Regulations

Particular attention must be paid to local and statutory regulations, etc. when installing machines and the plant (e.g. with regard to the specified escape routes). Note the safety zones in relation to adjacent machines.

# Maintenance

## General Safety Instructions

The machine shall be switched off, come to a standstill, and be secured so that it cannot be switched on again inadvertently before starting any maintenance work whatsoever. Use proper lockout/tagout procedures to secure the machine against inadvertent startup.

Remove any oil, grease, dirt and waste from the machine, particularly from the connections and screws, when starting the maintenance and/or repair work. Do not use any corrosive-cleaning agents. Use lint-free rags.

Retighten all screw connections that must be loosened for the maintenance and repair work. Any safety mechanisms that must be dismantled for setting-up, maintenance or repair purposes must be refitted and checked immediately after completing the work.

## Maintenance, Care, Adjustment

The activities and intervals specified in the Instruction Manual for carrying out adjustments, maintenance and inspections must be observed, and parts replaced as specified.

All hydraulic and pneumatic lines should be examined for leaks, loose connections, rubbing and damage whenever the machine is serviced. Any defects found must be remedied immediately.

## Waste, Disassembly, Disposal

Waste products should be cleared from the machine as soon as possible as not to create a fire hazard. Ensure that fuels and operating lubricants, as well as replacement parts are disposed of in a safe and ecologically acceptable manner. Note the local regulations on pollution control.

When scrapping (disassembling) the machine and its assemblies, ensure that these materials are disposed of safely. Either commission a specialist company familiar with the local regulations or note the local regulations when disposing of these materials yourself. Materials should be sorted properly.

# Repair

## Replacement Parts

We cannot accept any liability whatsoever for damage due to the use of parts made by other manufacturers or due to unqualified repair or modification of the machine.

## Repair, Electrical

The power supply must be switched off (master switch off) and secured so that it cannot be switched on again inadvertently before starting any work on live parts.

Those parts of the machine and plant on which inspection, maintenance or repair work is to be carried out must be isolated from the power supply, if specified. The isolated parts must first be checked to determine that they are truly de-energized before being grounded and short-circuited. Adjacent live parts must also be isolated.

The protective measures implemented (e.g. grounding resistance) must be tested before restarting the machine after all assembly or repair work on electric parts.

Signal generators (limit switches) and other electrical parts on the safety mechanisms must not be removed or bypassed. Only use original fuses or circuit overloads with the specified current rating. The machine must be switched off immediately if a fault develops in the electrical power supply.

The electrical equipment of our machines must be checked at regular intervals and any defects found must be remedied immediately.

If it is necessary to carry out work on live parts, a second person should be on hand to operate the emergency OFF switch or master switch with voltage release in the event of an emergency. The working area should be cordoned off and marked by a warning sign. Only use electrically insulated tools.

## Ventilation/Hazardous Gases

It is the end users responsibility to ensure adequate ventilation is provided to exhaust any and all noxious or hazardous gases that may be present in the working environment.

## Hydraulic and Pneumatic Systems

Work on hydraulic or pneumatic equipment shall only be carried out by persons with training, knowledge and experience of hydraulic systems. Pressure lines shall be depressurized before starting any repair work.

## General Liability

Liability for machine damage and personal injury is extinguished completely if any unauthorized conversions or modifications are undertaken. The machine must not be modified, enlarged, or converted in any way capable of affecting safety without the manufacturer's prior approval.

## Starting Machine Movements

Read the Instruction Manual carefully to establish which keys and functions start machine movements.

## A Word to the End User

The end user has sole responsibility to enforce the use of safety procedures and guards on the machine. Any other safety devices or procedures due to local regulations should be retrofitted in accordance to these regulations and/or the EC Directive on the safety of machines.

Operator's position must always be readily accessible. Escape routes must always be kept clear and safety areas should be identified.

## Safety Precautions

Safety should be a constant concern for everyone. Always be careful when working with this equipment. While normal safety precautions were taken in the design and manufacture of this equipment, there are some potential safety hazards.

**Everyone involved with the operation and maintenance of this equipment should read and follow the instructions in this manual.**

**Operate the equipment only as stated in this manual. Incorrect use could cause damage to the equipment or personal injury.**

**It is the owner's responsibility to make certain that the operator reads and understands this manual before operating this equipment. It is also the owner's responsibility to make certain that the operator is a qualified and physically able individual, properly trained in the operation of this equipment.**

Specific safety warning decals are located on the equipment near the immediate areas of potential hazards. These decals should not be removed or obliterated. Replace them if they become non-readable.

- ALWAYS keep safety shields and covers in place, except for servicing.
- ALWAYS operate equipment in daylight or with adequate working lights.
- Follow daily and weekly checklists, making sure hoses are tightly secured and bolts are tightened.
- ALWAYS watch and avoid holes or deep depressions.
- ALWAYS wear adequate eye protection when servicing the hydraulic system and battery.
- NEVER operate a poorly maintained machine.
- NEVER allow persons to operate this machine without proper instruction.
- NEVER put hands or feet under any part of the machine while it is running.
- NEVER attempt to make any adjustments or repairs to the machine while running. Repairs or maintenance should be performed by trained personnel only.
- NEVER work under the machine unless it is safely supported with mechanical stands, blocks or a hoist and blocks.
- NEVER touch hot parts of machine.

# General Machine Data

## Electrical / Pneumatic Setup

Electrical: 220 VAC, 15amp, 50/60 Hz Single Phase

Pneumatic: 80 PSI, 5 SCFM avg.  
Set the low-pressure switch to 60 PSI

## Initial Machine Setup

Position the machine in a desired location on a sound and reasonably level floor.

Make sure that there is sufficient lighting over the machine.

Remove all packing material.

Adjust the jack screws so that the casters are about 1/8" off the floor.

Connect electrical power and compressed air as specified above and in accordance to local codes.

Open the main control box door in front of the machine. Turn on the ON/OFF circuit breaker located in the top right corner by pressing the green button. The green light inside the button should illuminate.

Turn the main air lock-out valve (red knob before the main pressure regulator) to the ON position.

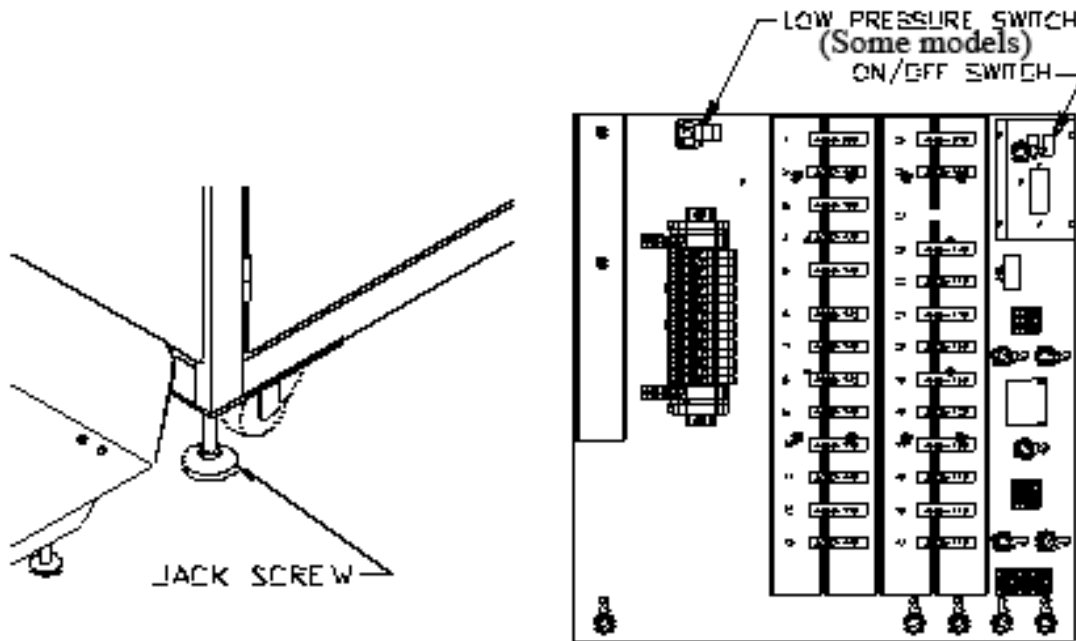

# Component Identification

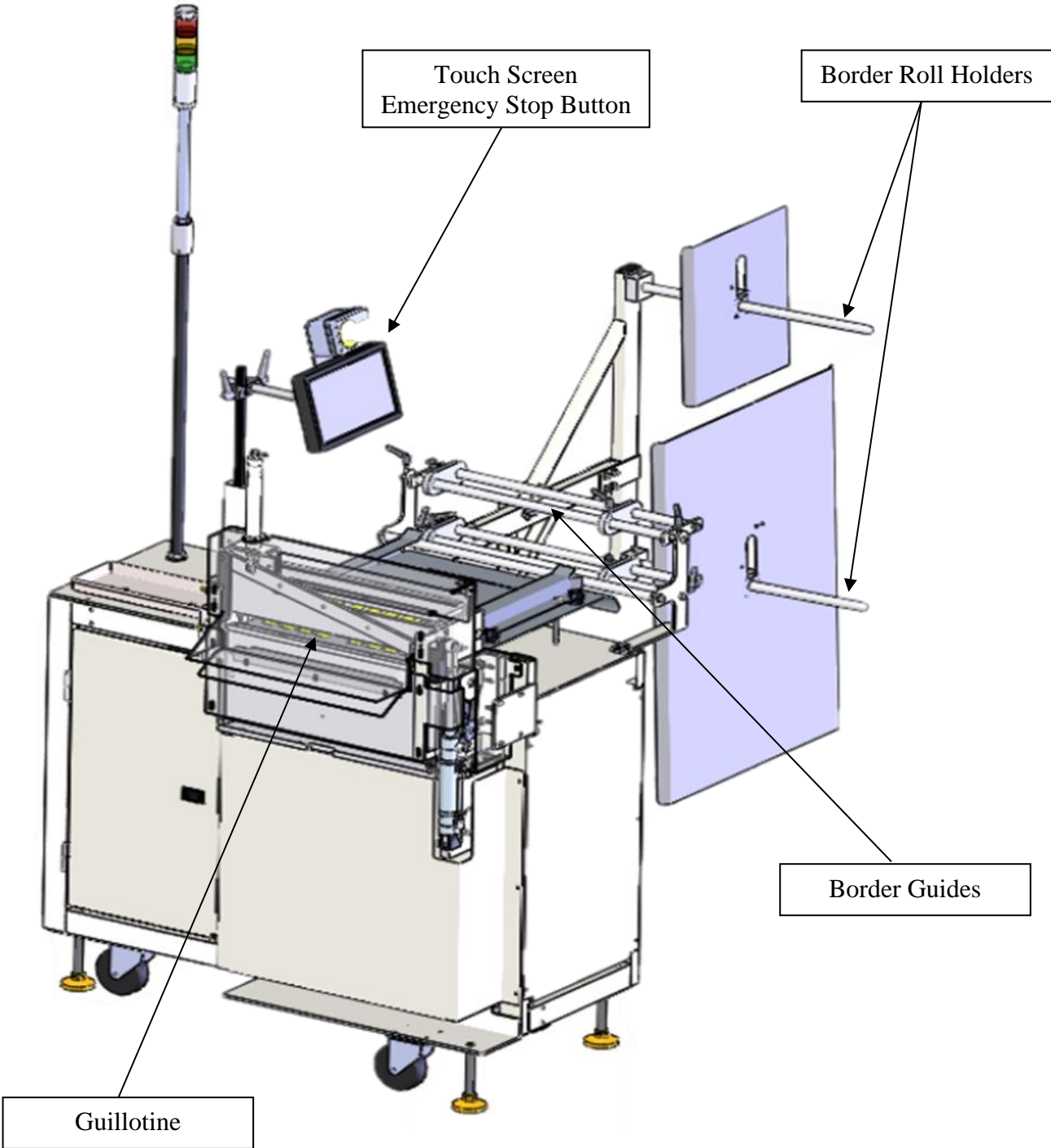

# Touch Screen Operation

The graphic images presented on the touch screen show “3-dimensional” buttons, which may be pressed to access other screens, change counters and timers, or actuate hardware. Areas lacking the “3 dimensional” border contain information only.

Counters are identified with the “+” and “-” buttons in the corners. These counters may be adjusted by pressing the “+” and “-” boxes. Pressing Reset from any screen clears all machine functions and returns to the main Ready page. Normal operation of the machine is controlled from the main Ready menu. From here you can start the Auto Cycle.

The main Ready menu allows anyone to access the necessary functions and adjustments needed for normal operation of the machine.

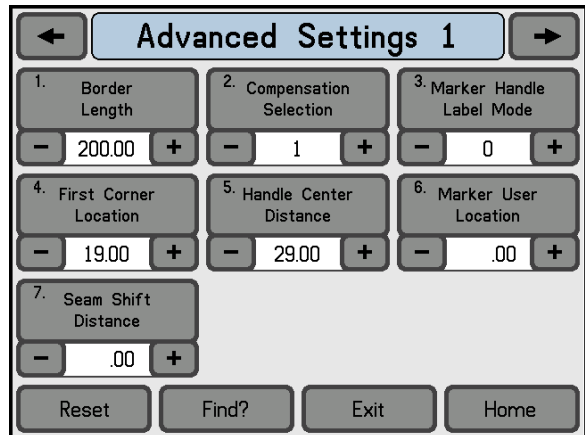

## Light Tower Function

The purpose of the 3200PB1E light tower is to indicate the operational status of the machine at some distance away from the machine. This makes it easy to see machine status at a glance. Definitions for the different light states currently available on the 3200 are included below.

Light Status	Definition
Green Steady	Normal, machine producing borders
Green Flashing	Machine producing borders but will stop soon for bobbin change.
Yellow Steady	Normal, machine powered but idling between borders.
Yellow Flashing	Machine stopped in middle of order and needs operator activity before continuing.
Red	Not currently utilized. Available for future use.

## Machine Operation

Turn on the power and select the desired language (if other than English) and wait until the touch screen displays the Ready – New Order screen.

### Initial Border Loading Procedure

Press the Open Rollers button, the Prefeed Roller and the Main Roller lift.

Open the Material Guides wider than the expected border width to be loaded.

Load a roll of border material on the Border Roll Holder. If the leading edge of the border is not of good quality, or it is not square, cut off the bad part and square off the leading edge. This will make the border loading process much easier.

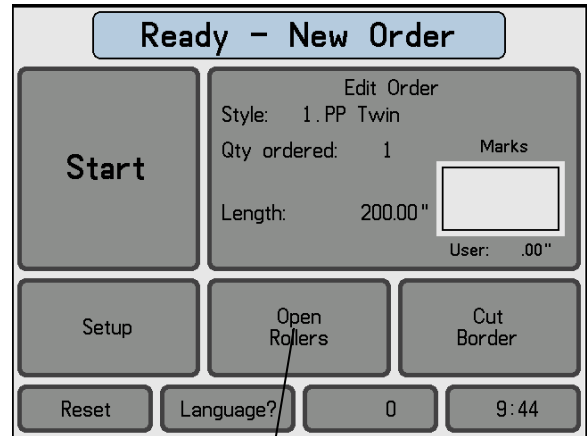

Feed the border between the 2" roller and the 3/4" rod, across the prefeed table, and between the prefeed drive rollers. Then feed over the upper rollers, through the guillotine and stop with the end of the border protruding slightly beyond the knife blades. Adjust the guides to fit the border size using the adhesive rulers provided. Hold the border in place and press the Close Rollers button. Be sure not to cover the Border Prefeed Slack Eye.

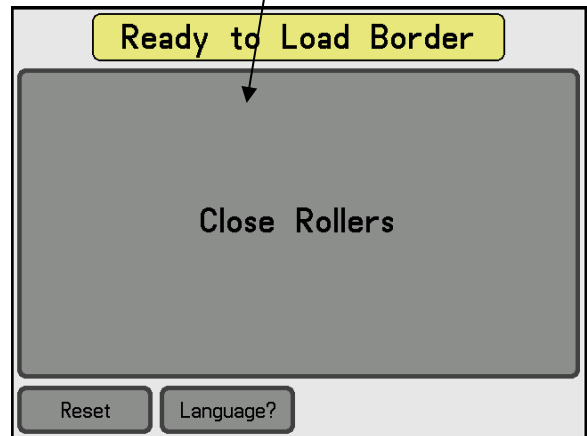

Note: If you get a message “Border Slack Warning” on the screen, walk over to prefeed part of the machine and press the Raise Roller push button mounted on the cover of the prefeed roller, pull the slack out, and press the button again to lower the prefeed roller. If the message “Border Slack Warning” comes up again with no slack present, most likely the slack eye is not adjusted properly to see the reflective tape on the side panel of the machine, or the eye is not working properly and needs to be checked.

### Border Splicing Method

When the machine runs out of border material, it stops and automatically back feeds about 10 inches to make the border splicing easier. The screen displays an “Out of Border Material” message. Load the next border roll on the pin and staple its leading edge to the trailing edge of the border currently in the machine.

Also, to make the operation of the 3200PB1E machine more efficient, the border splicing on the Sewing Station must be performed correctly.

## Setup Screen Information

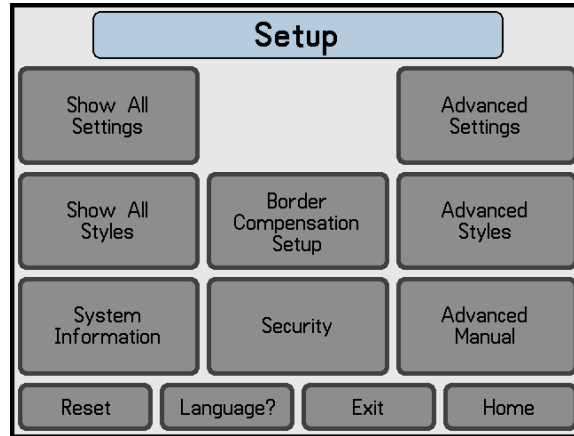

**Show All Settings:** When this button is pressed, all the values for the different settings are displayed in a table format.

**Show All Styles:** Pressing this button allow users to see all border styles entered in the machine.

**System Information:** Pressing this button allows users to view the machine version and serial number, the software revision and controller serial number, and the total piece count.

**Border Compensation:** Pressing this button allows the user to calibrate border lengths and test for accuracy of lengths.

**Security:** Pressing this button allows the user to raise their security clearance with a 5-digit security code.

**Advanced Settings:** Pressing this button gives access to 4 screens of adjustments that can be made. When a button on one of the screens is pressed, it will explain what the adjustment is and allow the adjustment to be made.

**Advanced Styles:** Pressing this button gives access to 2 screens to enter all specifications of a border and label the style for easy access later by the operator.

**Advanced Manual:** Pressing this button gives access to 2 screens to manually activate different border feed functions of the machine and review I/O signals related to sensors and encoders. It also allows the operator to turn on/off a border marker function if equipped and review the light tower functions.

# Styles

When installing the Model 3200PB1E border machine, it is necessary to first obtain new default border lengths for all mattress sizes. To obtain these lengths determine which border-making table will be used to check the borders coming off the 3200PB1E machine. Using this table, a measurement of every border size needs to be made by wrapping a measuring tape around the arm and measuring to the cut mark for each border size.

## Entering New Styles

After all the default border lengths have been recorded, they must be stored in the controller of the 3200PB1E machine. To store the default border lengths into a new style, press Setup button on Ready Screen and then press Advanced Styles button. Following this step, press the Style Edit Menu which takes you to the Edit Styles Menu screen where you will locate and press a blank style number. After entering a description in the white box, press the top right arrow button and enter the numerical style information.

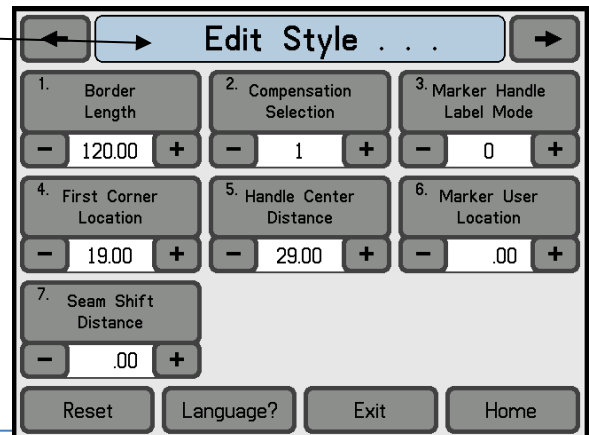
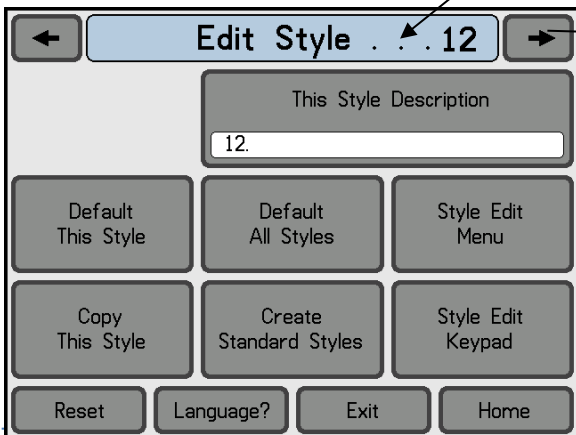
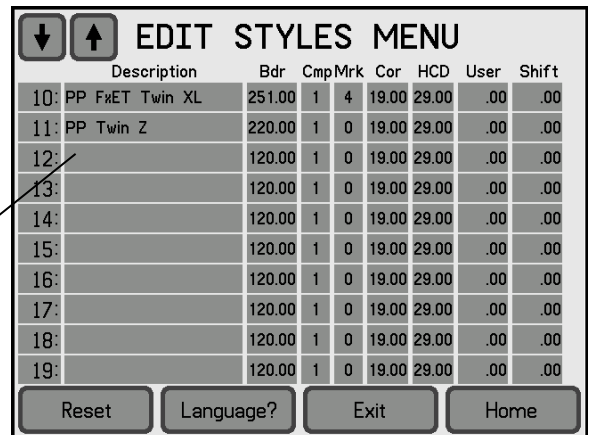
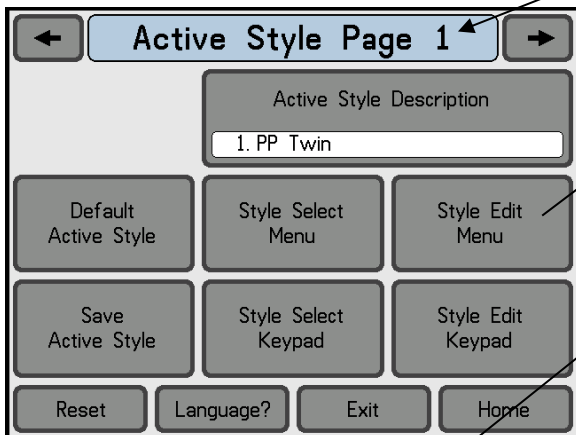
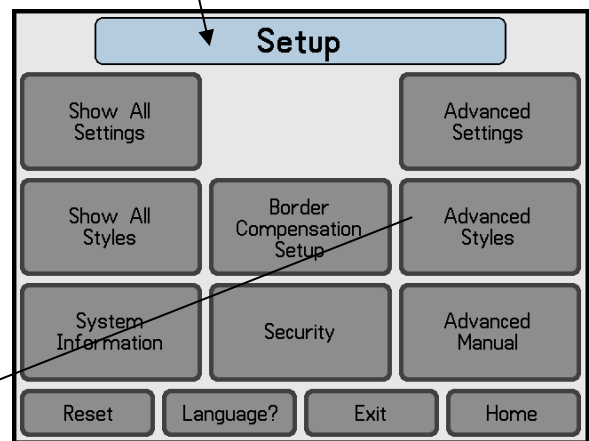
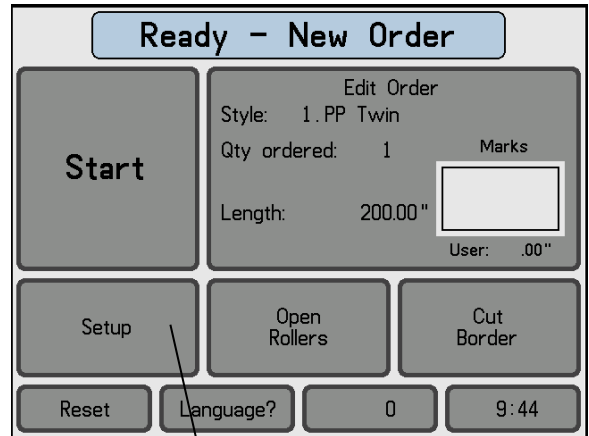

## Edit Styles

There are several ways or paths to access the Edit Styles Menu.

### Option 1:

On the Setup page, press Advanced Styles button to access the Active Style Page screens.

On the Active Style, page press the Style Edit Menu button to access the Edit Styles Menu screen and locate the style number to be changed such as #1

After pressing the style number, the Edit Style 1 page will open with the Style shown in the white box at the top.

Press the right top arrow button and enter the changes on the next Page shown as Edit Style.

Press Exit or Home when finished.

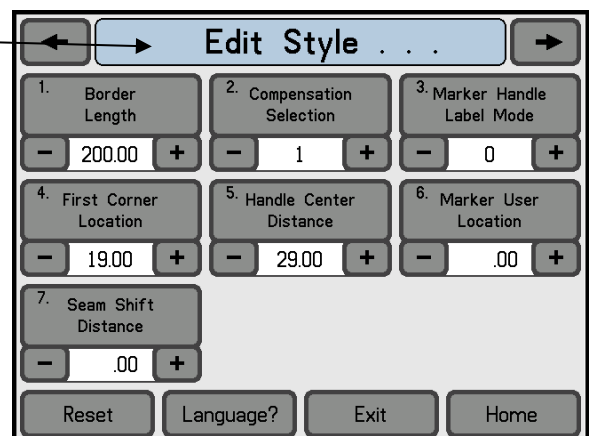
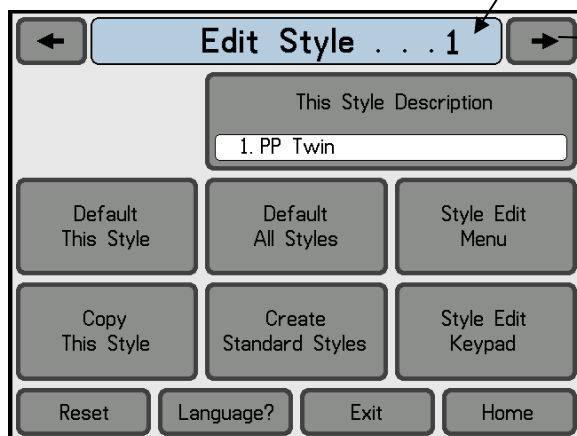
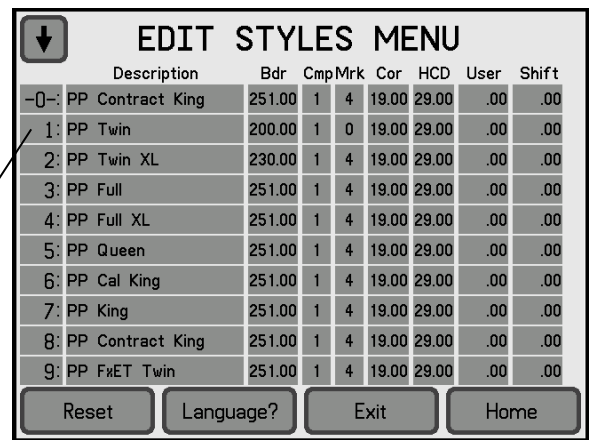
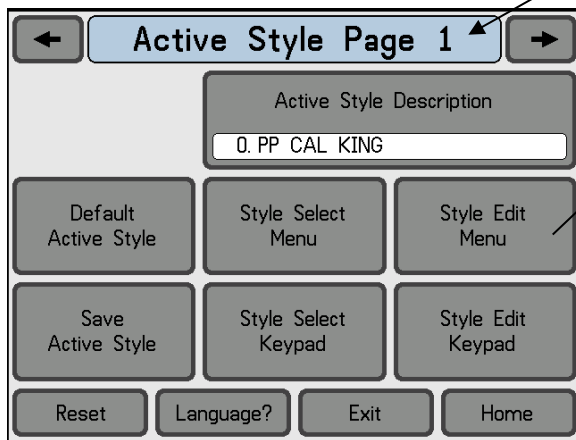
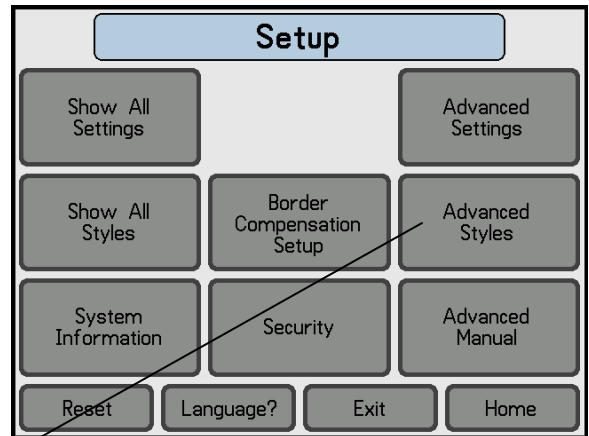

**Option 2:**

On the Setup Page, press Show All Styles button to access the List of Styles.

At the bottom right of this page press the Edit Styles button to access the Edit Styles Menu screen and locate the number to be changes such as # 5.

After pressing the style number, the Edit Style 5 page will open with the Style shown in the white box at the top.

Press the right top arrow button and enter the changes on the next Page shown as Edit Style.

Press Exit or Home when finished.

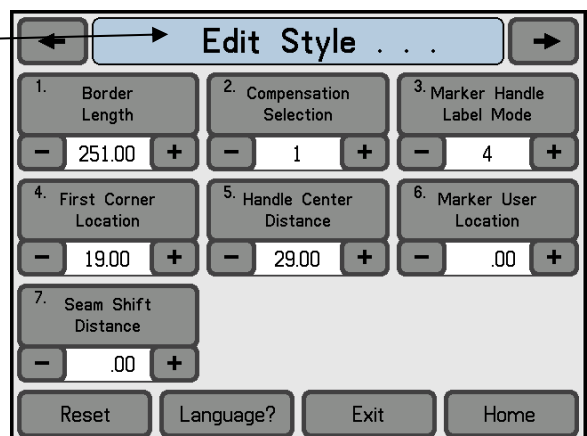
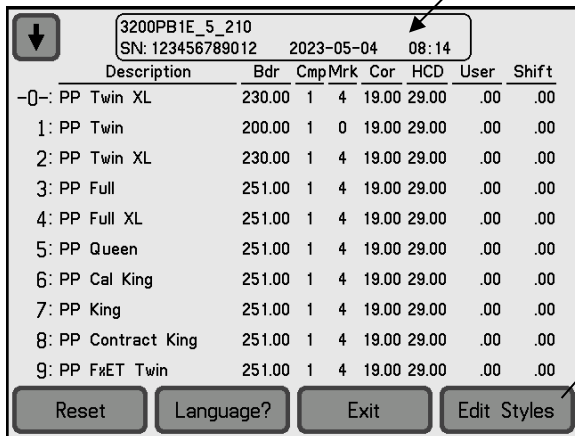
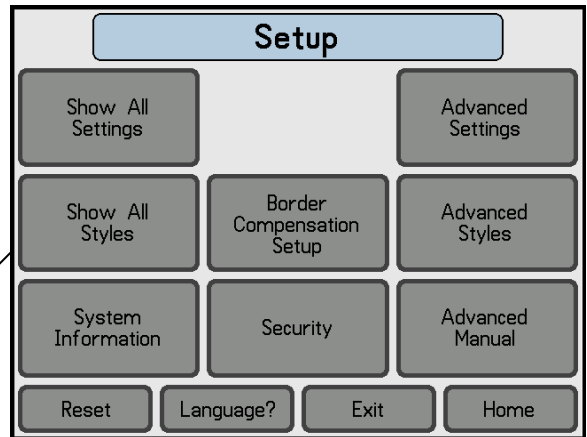

### Selecting Styles

To setup the machine to make the desired borders go to the main Ready – New Order screen and press the large Edit Order button.

The new screen Edit Order displays all available options: the style and quantity of borders.

Press the Style Select Menu button to select the desired combination from the list or press the Style Select Keypad and enter a number from the list to select the style. When finished, press **Exit** button to get back to the main Ready – New Order screen. You are now ready to make borders.

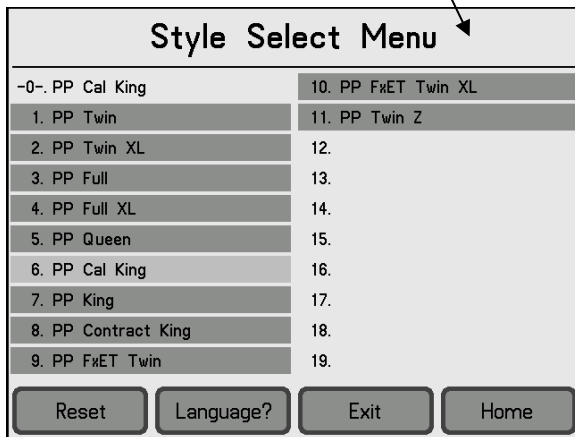
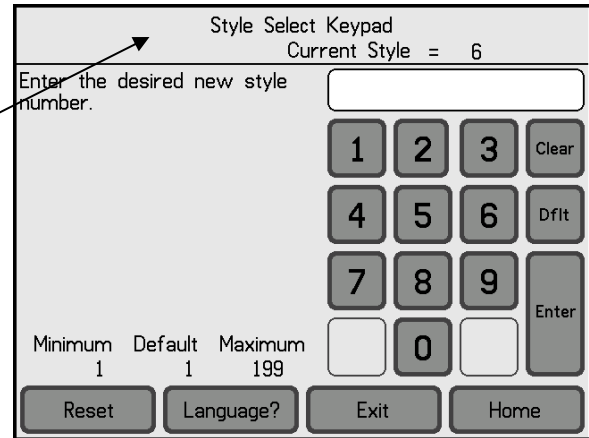
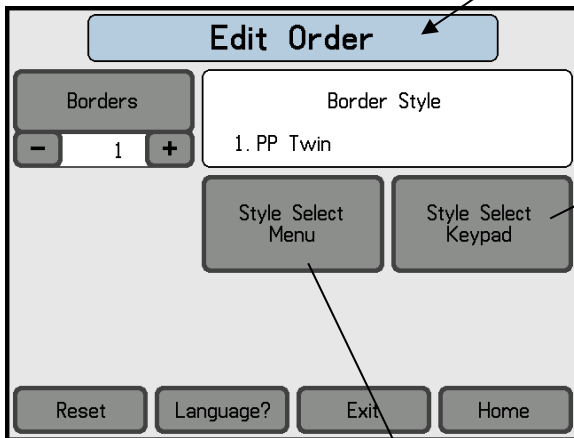
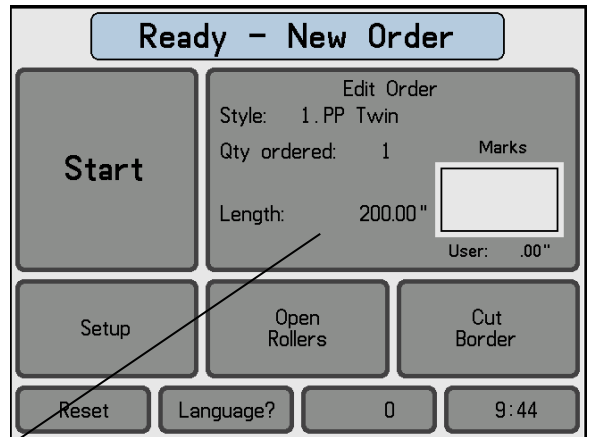

## Factory Pre-set Machine Adjustments

The following adjustments will have already been made before the unit is shipped from the factory.

Adjust the spring screw on the guillotine to make sure the blade cuts the material.

Adjust the roller down cylinder so that the rollers touch with little or no pressure.

Adjust the cylinders on the prefeed rollers the same.

Adjust the counterbalance springs on the prefeed seam detector rollers to counterbalance 70% of the weight.

Step motor speed

Prefeed		Feed	
Slow	135 RPM	Slow	28 RPM
Fast	163 RPM	Fast	151 RPM

# Operational Path of Screens

## Ready Screen



## Reset Screen

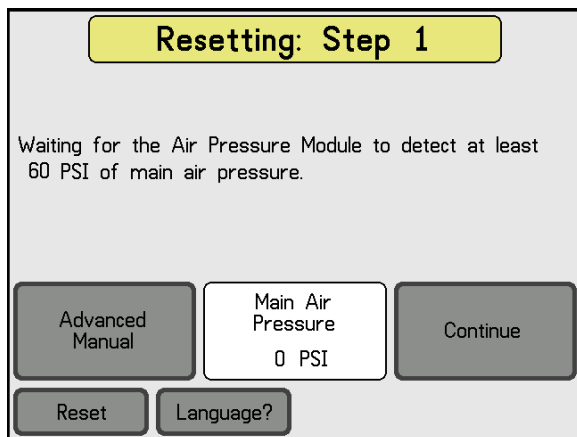

## Language Screen



## Piece count

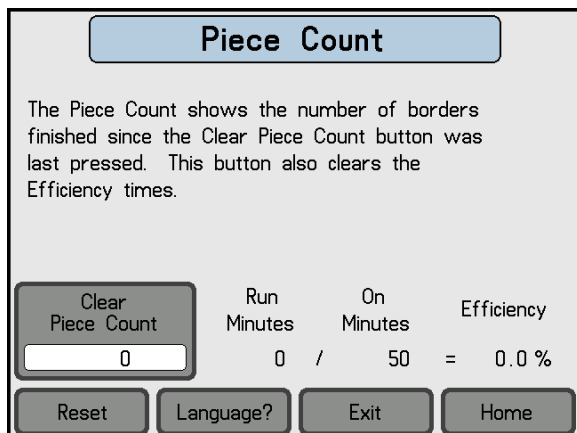

## Clock Screen

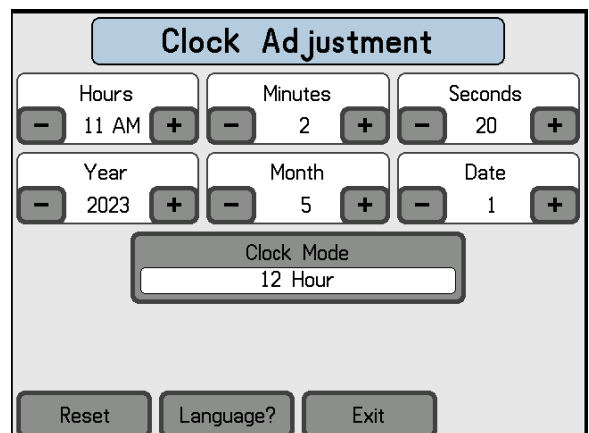

### Edit Order

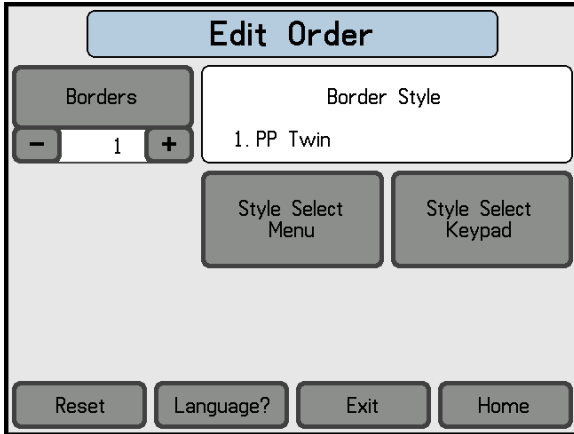

### Style Select Menu

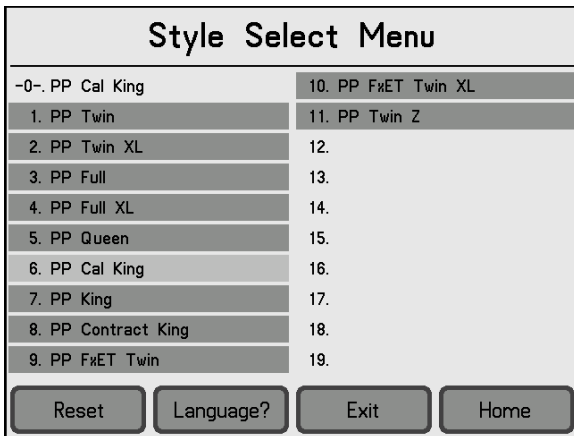

### Style Select Keypad

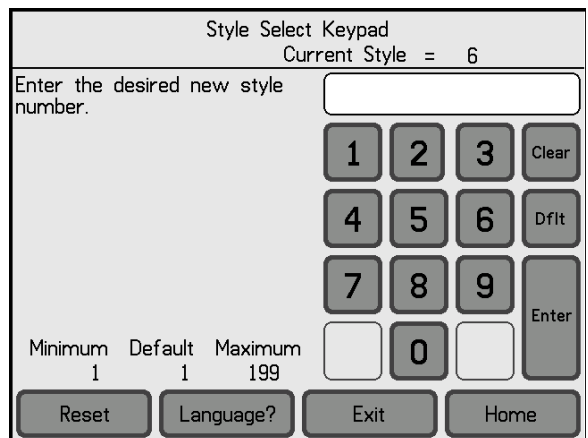

### Open / Close Roller

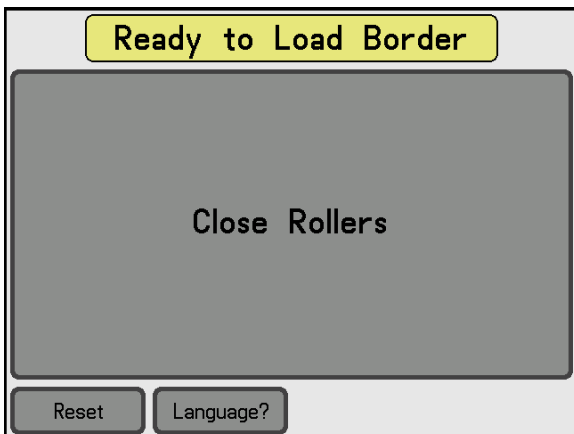

### Cut Border Screen



**Setup**

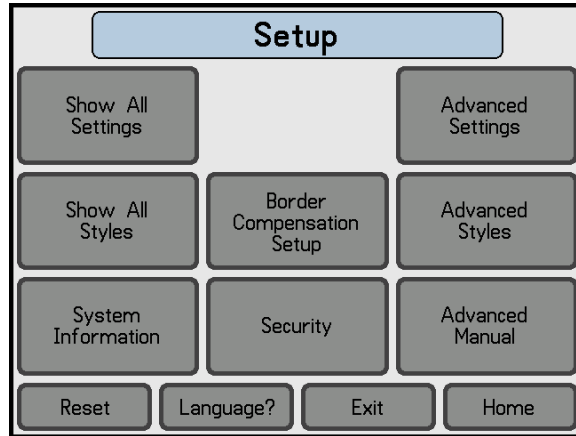

**Show All Settings**

3200PB1E_5_210 SN: 123456789012 2023-05-01 10:28										
	0	1	2	3	4	5	6	7	8	9
0		120.00	1	0	19.00	29.00	.00	.00	—	—
10	0	—	—	—	—	.6	13.60	1.0	—	60
20	1	—	47	0	0	0	1	0	—	—
30	—	—	—	—	—	—	—	7750	7750	7750
40	7750	7750	7750	7750	7750					
50										
60										
70										
80										
90										

**Show All Styles**

3200PB1E_5_210 SN: 123456789012 2023-05-01 11:13							
Description	Bdr	Cmp	Mrk	Cor	HCD	User	Shift
-0-:	120.00	1	0	19.00	29.00	.00	.00
1: PP Twin	200.00	1	0	19.00	29.00	.00	.00
2: PP Twin XL	230.00	1	4	19.00	29.00	.00	.00
3: PP Full	251.00	1	4	19.00	29.00	.00	.00
4: PP Full XL	251.00	1	4	19.00	29.00	.00	.00
5: PP Queen	251.00	1	4	19.00	29.00	.00	.00
6: PP Cal King	251.00	1	4	19.00	29.00	.00	.00
7: PP King	251.00	1	4	19.00	29.00	.00	.00
8: PP Contract King	251.00	1	4	19.00	29.00	.00	.00
9: PP FxET Twin	251.00	1	4	19.00	29.00	.00	.00

**System Information**

System Information 2023-05-01 11:15	
Machine	
Model:	3200PB1E
Description:	Border Measure/Cut Workstation
Serial Number:	123456789012
Total Pieces:	0000000000
Software	
Name:	3200PB1E_5
Version:	210
Atlanta Attachment Company Service Department (USA)	
Phone:	+1 (770) 963-7369
Fax:	+1 (770) 963-7641
Email:	techsupport@atlatt.com

**Security**

**Engineer**

To lower your security clearance, enter the 5 digit security code and press ENTER.

Lower Security Clearance

Security Code

Bypassed

1

2

3

Clear

4

5

6

7

8

9

Enter

0

## Border Compensation

Border Compensation Tests			
Feed Compensation 1	Border Comp Test Select		
- 7750 +	- 1 +		
Feed 300 Inches	Open Rollers		
Feed Test Measured Inches			
- 300.0 +			
Feed Comp Auto Correct			
Reset	Language?	Exit	Home

## Advanced Settings

Advanced Settings 1			
1. Border Length	2. Compensation Selection	3. Marker Handle Label Mode	
- 120.00 +	- 1 +	- 0 +	
4. First Corner Location	5. Handle Center Distance	6. Marker User Location	
- 19.00 +	- 29.00 +	- .00 +	
7. Seam Shift Distance			
- .00 +			
Reset	Find?	Exit	Home

Advanced Settings 2			
10. Border Chop Mode			
- 0 +			
		15. Marker On Time	
		- .6 +	
16. Knife to Marker Distance	17. Closer Margin		
- 13.60 +	- 1.0 +		
Reset	Find?	Exit	Home

Advanced Settings 3			
19. Main Air Lower Limit	20. Border Out Eye Mode		
- 60 +	- 1 +		
22. On Minutes	23. Run Minutes	24. Piece Count	
155	0	0	
25. Borders Done	26. Borders Ordered	27. Style	
0	1	0	
Reset	Find?	Exit	Home

Advanced Settings 4			
37. Feed Compensation 1	38. Feed Compensation 2	39. Feed Compensation 3	
- 7750 +	- 7750 +	- 7750 +	
40. Feed Compensation 4	41. Feed Compensation 5	42. Feed Compensation 6	
- 7750 +	- 7750 +	- 7750 +	
43. Feed Compensation 7	44. Feed Compensation 8		
- 7750 +	- 7750 +		
Reset	Find?	Exit	Home

### Find Settings

FIND SETTINGS										
	0	1	2	3	4	5	6	7	8	9
0		120.00	1	0	19.00	29.00	.00	.00	—	—
10	0	—	—	—	—	.6	13.60	1.0	—	60
20	1	—	102	0	0	0	1	0	—	—
30	—	—	—	—	—	—	—	7750	7750	7750
40	7750	7750	7750	7750	7750					
50										
60										
70										
80										
90										

Reset    Language?    Exit    Home

### Advanced Styles

← **Active Style Page 1** →

Active Style Description  
1. PP Twin

Default Active Style    Style Select Menu    Style Edit Menu

Save Active Style    Style Select Keypad    Style Edit Keypad

Reset    Language?    Exit    Home

← **Active Style Page 2** →

1. Border Length - 200.00 +	2. Compensation Selection - 1 +	3. Marker Handle Label Mode - 0 +
4. First Corner Location - 19.00 +	5. Handle Center Distance - 29.00 +	6. Marker User Location - .00 +
7. Seam Shift Distance - .00 +		

Reset    Language?    Exit    Home

### Advanced Manual

← **Advanced Manual 1** →  
Border Feed

Border Knife Up Down    Feed Encoder Ch A 0 RPM Ch B

Border Knife Down    Slow Reverse    Slow Forward

Feed Rollers Open    Fast Reverse    Fast Forward

Border Out Eye

Reset    Language?

← **Advanced Manual 2** →  
Marker & System

Marker

Red Light

Yellow Light

Green Light

Air Pressure 0

Reset    Language?

## On-Board Diagnostics

### Typical Example of Warning Pages

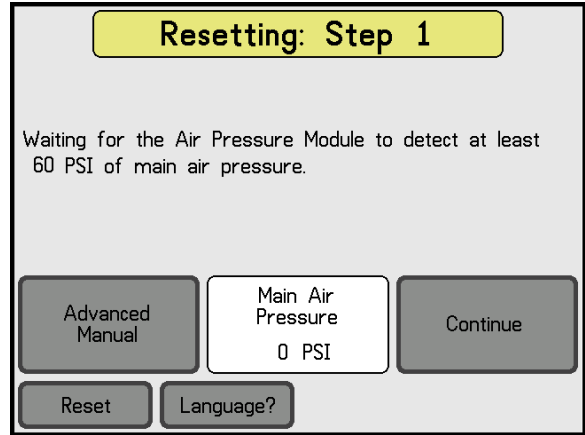

## Help Screens.

Accessible by pushing at the top-middle section of a Button.

### Typical Examples of Help Pages

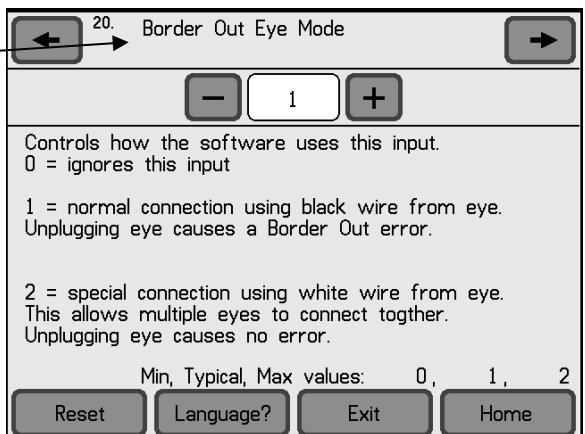
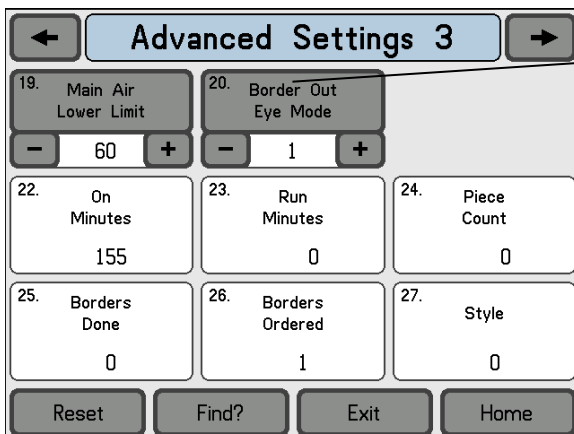
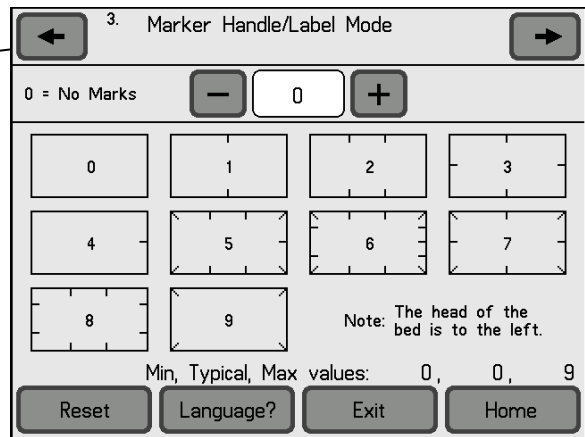
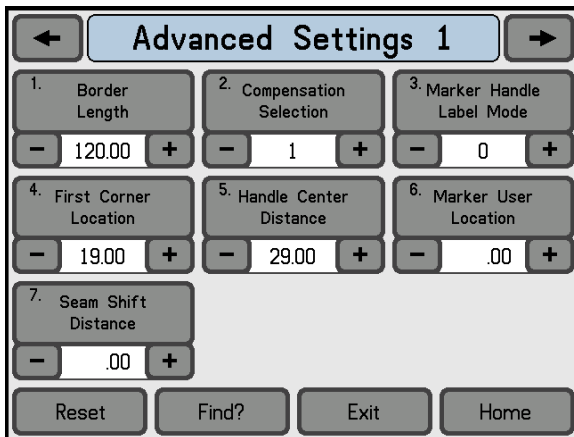

# 3200PB1E Main Feed Motor, Parameter Setting

S		33200PB1, 1E MAIN FEED	
Before Programming, Perform a Master Reset of Parameters (See Below)			
PARAMETER	RANGE	VALUE	DESCRIPTION
290		0	Mode of operation. MUST SET THIS PARAMETER FIRST!
026		0	Pedal Function, analog off
110	700-3900	0700	Pos Speed
121	300>	0300	Lower limit for Par 111 (must set before 111)
111	0-9990	1200	Maximum speed when "129" is 0, 1, or 2.
119	1-3	1	Linear acceleration
153	0-50	35	Braking power at standstill
161	0-1	1-CCW	Motor rotation
207	1-55	35	Braking
220	1-55	1	Acceleration
240	0-56	55	Enable reverse run of motor with input 1
270	0-5	5	No handwheel sensor
272	0200-2550	1000	Drive ratio between motor pulley and handwheel pulley. If handwheel pulley is smaller than motor pulley, increase this value to slow down sewing head until measured speed matches speed set with parameter 111.
436		0	
401		1	
Front panel LED's:		<b>Programming Instructions:</b>	
LED 1:	Off	1. Power on holding down the "P" button till "CODE" is displayed.	
LED 2:	Off	2. Press ">>" once and enter the number "5913"	
LED 3:	Off	3. Press "E" once and "4.0.0." is displayed this is a parameter	
LED 4:	Off	4. Proceed to the parameter to be changed and press "E"	
LED 5:	Off	5. The value now shows in the screen, adjust to desired value.	
LED 6:	Off	6. Press "E" to enter value and continue with parameter setting.	
LED 7:	Off, Stop at needle down.	7. Repeat for other parameters, press "P" once when complete.	
LED 8:	Off	8. Run sewing head to save parameters before powering down	
		<b>To Perform Master Reset of Parameters:</b>	
		1. Power on holding down the "P" button till "CODE" is displayed.	
		2. Press ">>" once and enter the number "5913"	
		3. Press "E" twice and "093" is displayed.	
		4. Press "+" once, "094" is displayed.	
		5. Press "P" to exit programming mode with all default values.	
Speed	RPM	Treadle/Low	
Fast	160	C	
Slow	30	A, C	

## Machine Maintenance

Regularly scheduled maintenance of the 3200PB1E unit reduces possible problems and downtime. Proper care will also ensure a longer life and better performance of the machine.

Perform the following procedures to properly maintain the machine.

1. Clean the machine daily at the end of every shift.
  - A. Wipe all photo eye lenses with a clean, nonabrasive, dry cloth.
  - B. Use blow-off hose to get rid of excess lint, thread and other clippings.
2. Check air filters weekly; replace filter elements once every six months.
3. Lubricate the bearing block on the guillotine knife once every three months using standard sewing head oil. The oiling hole is located on the top face of the bearing block, and it is indicated by a red paint mark.
4. Apply Accrolube™ grease to the recessed cavity on the back side of the top blade side plate of the guillotine knife. This will improve performance and extend the life of the blade.

## Electric Eye Sensor Adjustment

To adjust the sensor, first remove the clear plastic cover from the end of the sensor. There are two adjusting screws under the cover. One is labeled “GAIN” and is used to set the sensitivity of the sensor. The other screw is labeled “DO & LO” and should always be fully clockwise.

With the end of the sensor pointing at the center of the reflective tape, turn the “GAIN” screw counter-clockwise until the red LED indicator is off. Then turn the “GAIN” screw clockwise until the LED indicator comes on. Then turn the “GAIN” screw one full turn clockwise. The LED indicator should be blinking slowly. Cover the eye so that the sensor cannot see the reflective tape and the LED should go off.

## Reflective Tape Maintenance

Use a soft cloth for cleaning.

Do not use chemicals or abrasives to clean it.

Avoid any contact with oils and liquids.

Do not touch the tape with bare fingers.

If tape is dirty or opaque, the eye may not function correctly.

## Assembly Drawings & Parts Lists

The materials contained herein are confidential and proprietary information of Atlanta Attachment Company. In addition to any confidentiality and non-disclosure obligations that currently exist between you and Atlanta Attachment Company, your use of these materials serves as an acknowledgment of the confidential and proprietary nature of these materials and your duty not to make any unauthorized use or disclosure of these materials.



**Atlanta**  
PARTS DEPOT

**One-Stop Shopping**  
For Expendable Replacement Parts for AAC & Other Bedding Equipment Suppliers  
Toll Free: **1-866-885-5100**  
[www.atlantapartsdepot.com](http://www.atlantapartsdepot.com) • [sales@atlantapartsdepot.com](mailto:sales@atlantapartsdepot.com)

# 33200PB1E. Border Workstation, Measure & Cut

AAC Drawing Number 9002647 Rev 0

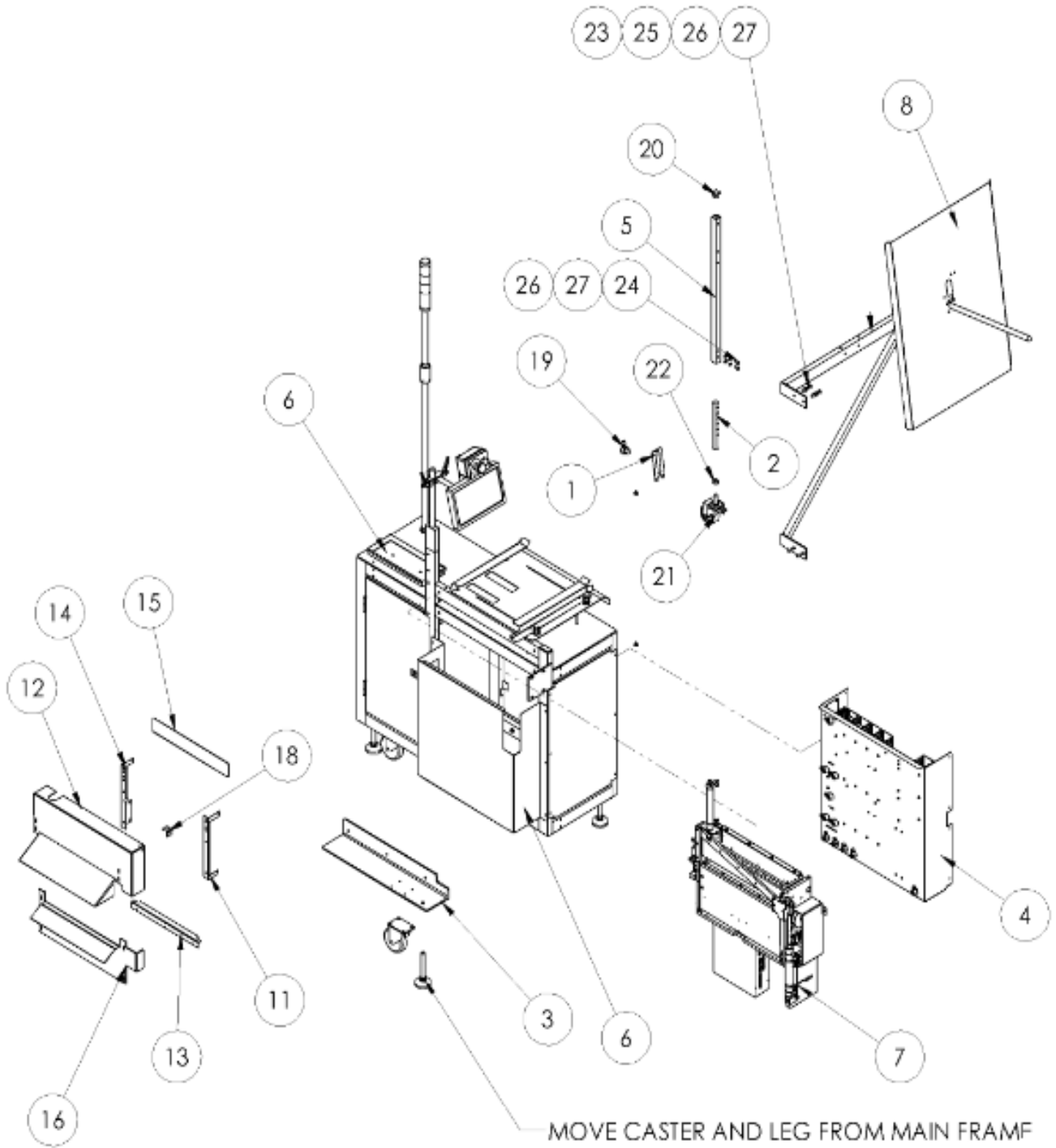

33200PB1E parts list

ITEM	QTY	PART NUMBER	DESCRIPTION
1	1	1961-255	BRACKET, SENSOR MTG
2	1	26127	LEG FOR AP-26-02
3	1	3200212	PLATE, CASTER EXTENSION
4	1	3200213	CONTROL PANEL
5	1	3200214	LEG, ROLL HOLDER
6	1	32003000PA1	MAIN FRAME ASSEMBLY
7	1	32004000PB1	GUILLOTINE ASSEMBLY
8	1	32007700P	ROLL HOLDER ASSY
9	AR	3200PB1E-PD1	DIAGRAM, PNEUMATIC, A/P MODULE
10	AR	3200PB1E-WD1	DIAGRAM, WIRING, A/P MODULE
11	1	33004033A	BRKT, GUARD, RIGHT SIDE
12	1	33004034B	GUARD, TOP HALF, 3300RA
13	1	33004035	GUARD, BOTTOM
14	1	33004037	BRKT, GUARD, LEFT SIDE
15	1	33004048B	SHIELD, TOP, GUILLOTINE
16	1	33004055A	COVER, BOTTOM GUILLOTINE
17	AR	3300A-FEEDPAR	PARAMETER SETTINGS
18	1	98-6819a	BRKT, CORNER 2 x 10-32
19	1	FFT18FF100Q	EYE, FIXED FIELD, 4IN
20	1	MM132-1202	END CAP, SQUARE, BLACK
21	1	MM503022LB	CASTER, 3" LOCKING
22	1	NNH1/2-13	NUT, HEX, 1/2-13
23	4	NNH1/4-20	NUT, HEX, 1/4-20
24	2	SSHCO1048	1/4-20 X 3/4 HEX CAP
25	4	SSHCO1112	1/4-20 X 1-3/4 HHCS
26	10	WWFS1/4	WASHER, FLAT, SAE, 1/4
27	6	WWL1/4	WASHER, LOCK, 1/4

# 32003000PA1 Main Frame Assembly

AAC Drawing Number 192131A Rev 5

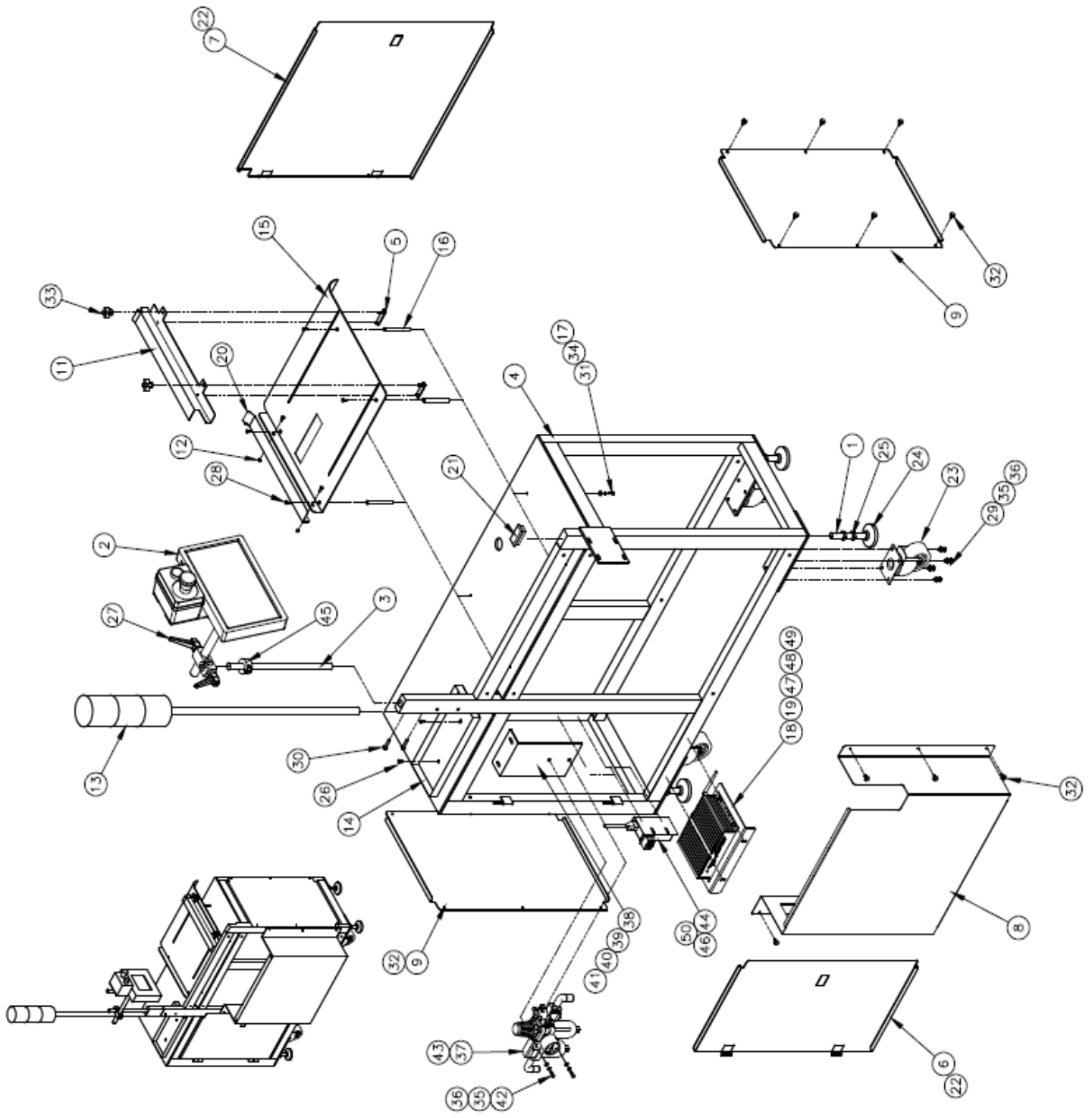

32003000PA1 parts list

ITEM	QTY	PART NUMBER	DESCRIPTION	ITEM	QTY	PART NUMBER	DESCRIPTION
1	4	0411-1063	ROD, FULL THREAD, 5/8-11 X 5"	26	2	SSBC98024	SCREW, BUTTON CAP 10-32 x 3/8
2	1	4082006	HMI POLE MOUNT WITH BEND UP, W	27	2	TTH32426	HANDLE, THRD, 5/16-18X1-1/4
3	1	28203	ROD, STRAIGHT, 1018 3/4OD, 14.	28	6	SSFC90024	SCREW, FLAT ALLEN CAP 8-32X3/8
4	1	32003500P	FRAME ASSY 3200P	29	16	SSHC01040	SCREW, HEX CAP 1/4-20X5/8
5	2	32004035A	PLATE, NUT W/STUD, 1/2 @ 1.50	30	2	SSHC01064	SCREW, HEX CAP 1/4-20X1
6	1	32005011	DOOR, FRONT 3200P	31	4	SSSC90048	SCREW, SOCKET CAP 8-32X3/4
7	1	32005012	DOOR, REAR 3200P	32	18	SSZS93032	SCREW, SHEET METAL 10-16X1/2,
8	1	3200180	PANEL	33	2	TTCL1APPK1	KNOB, PLASTIC, 1-1/4 DIA THREA
9	2	32005015	PANEL 3200P	34	4	WWF8	WASHER, FLAT, 8
10	1	32005027	PANEL 3200P	35	20	WWFS1/4	WASHER, FLAT, SAE, 1/4
11	1	32005526	GUIDE, GUILLOTINE 3200P	36	20	WWL1/4	WASHER, LOCK, 1/4
12	2	NNK8-32	KEP W/ RETAINED LOCK WASHERS	37	1	AA198-5110	FILTER/REGULATOR/LOCKOUT WITH
13	1	33001130	LIGHT ASSY 3300	39	2	SSBC98024	SCREW, BUTTON CAP 10-32X3/8
14	1	33005534	TOOL TRAY, 1X5X12	39	2	SSSC98024	SCREW, SOCKET CAP 10-32X3/8
15	1	33005605A	PLATE, CLOTH 3200P	40	2	WWL10	WASHER, LOCK, 10
16	4	33005623	STANDOFF 3300	41	2	WWFS10	WASHER, FLAT, SAE, 10
17	4	WWL8	WASHER, LOCK, 8	42	2	SSSC01048	SCREW, SOCKET CAP 1/4-20X3/4
18	1	EEJBC375CG	GATEWAY PC, W/PWR CABLE, SERIA	43	2	AAQME-3-4	MALE ELBOW 3/8OD TUBE 1/4 NPT
19	1	13061459	PC MOUNT PLATE, 1306	44	2	FF264-341	TERMBLK, WAGO, TOP, DUAL, GRY
20	1	3200090	GUIDE, RH, 3200PB	45	1	CCCL12F	COLLAR, CLAMP, 3/4 BORE STEEL,
21	1	MM132-1496	END CAP, RECT, BLACK 1 X 2 X 1	46	1	FF264-371	TERMBLK, WAGO, TOP, END GRAY
22	2	MM40450010	LATCH, DOOR SLIDE LOCK	47	4	NNK10-32	NUT, KEP, 10-32
23	4	MM431-4	CASTER, 4", W/LOCKS 350LB CAPA	48	2	SSBC01096	SCREW, BUTTON CAP 1/4-20X1-1/2
24	4	MMML-2	LEVELING FOOT, 5/8-11 SOCKET,	49	2	NNH1/4-20	NUT, HEX, 1/4-20
25	8	NNSH5/8-11	NUT, SQUARE HEAD, 5/8-11	50	1	4082004	PC POWER BLOCK BRACKET, 12V PO

# 32004000PB1 Guillotine Assembly

AAC Drawing Number 192138A Rev 2

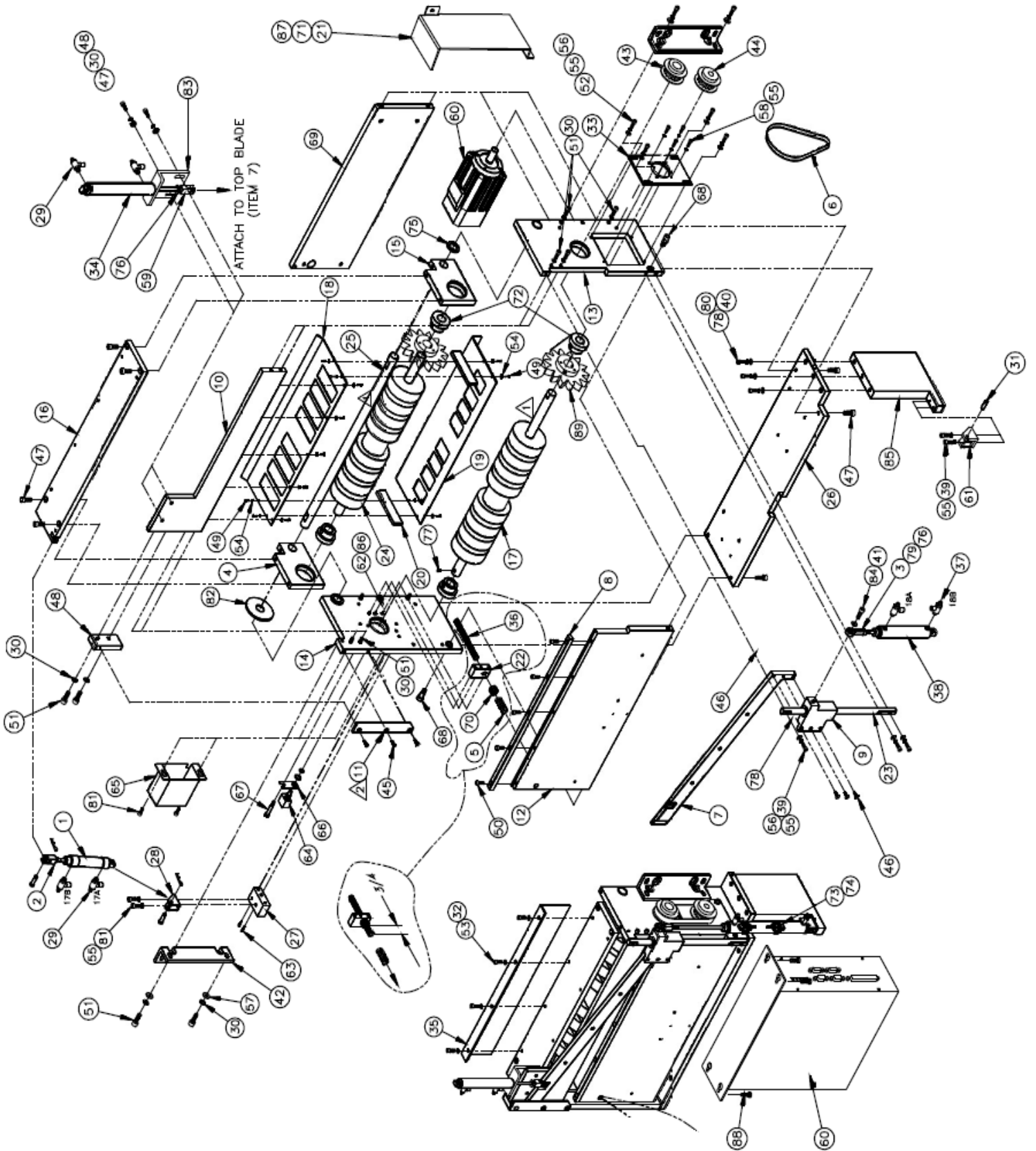

32004000PB 1 parts list

Item	QTY	Part Number	Description
1	1	AA C7DP-1	CYLINDER, AIR, DA 3/4 BORE, 1
2	1	AA FCT-7	CLEVIS, AIR CYLINDER 1/4-28 TH
3	1	BB AW-7	BEARING, ROD END, FEMALE 7/16-
4	1	33004014	ARM, TOP RIGHT 3300
5	1	RRLC092H6	SPRING, COMP, .092X.60X1.5 R-1
6	1	GG150L050	BELT, GEAR, 3/8P, 1/2W 40 TEET
7	1	3200133	BLADE, TOP, 15" CAP 3200PC
8	1	33004002A	BLADE, BOTTOM, 15" CAP 3300
9	1	3200082	BLOCK, GUIDE, TOP BLADE 3200PB
10	1	3200350	BAR, TIE
11	1	3200130	PLATE, RUB, TOP BLADE 3200PC
12	1	3200349	PLATE, HINGE GUILLOTINE ASSY,
13	1	3200121	PLATE, FRONT SLIDE GUILLOTINE
14	1	33004008	PLATE, REAR SIDE 3300
15	1	33004009	ARM, TOP LEFT 3300
16	1	33004010	PLATE, BACK 3300
17	1	33004020	ROLLER, BOTTOM, DRIVE 3300
18	1	3200351	GUARD, TOP ROLLER
19	1	3200352	GUARD, BOTTOM ROLLER 3200P
20	2	33004015	GUIDE, MATERIAL, INTERNAL 3300
21	1	3200178	GUARD, GUILLOTINE
22	1	33004017	BLOCK, SPRING 3300
23	1	3200124	SHAFT, TOP BLADE 3200PC
24	1	33004011	ROLLER, TOP, IDLER 3.183 D 330
25	1	33004021	SHAFT, FLA, JR, 75OD, 19.09L
26	1	3200127	PLATE, BASE 3200PC
27	1	32004063	MOUNT, AIR CYLINDER 3300
28	1	AA FBP-11C	BRKT, PIVOT, 1/4 BORE AAC 6, 7
29	4	AA 198RA508	FLOW CONTROL, 5/32 X 1/8"
30	16	WWL1/4	WASHER, LOCK, 1/4
31	1	IID016X064	DOWEL PIN, 1/4 X 1
32	4	WWS110	WASHER, INTERNAL TOOTH, 10 LOC
33	1	33004027A	PLATE, CONVERSION, GUILLOT 320
34	1	AA C095DP	CYLINDER, AIR, DA, 5" STRK 1-1/
35	1	33004050	GUARD, TOP GUILLOTINE 3300
36	1	33004031	POST, SPRING 3300
37	2	AA 198RA 408	FLOW CONTROL, 1/4 X 1/8 NA S220
38	1	AA CM125DP	CYLINDER, AIR, DA W/MAGNET 1-1
39	5	SSSC95064	SCREW, SOCKET CAP 10-24X1
40	3	WWL5/16	WASHER, LOCK, 5/16
41	1	WWL7/16	WASHER, LOCK, 7/16
42	2	33004058A	BRKT, MOUNT, GUILLOTINE 3200P
43	1	PP24LB050M3	PULLEY, GEAR, 3/8P, 24T, 3/4B
44	1	PP10LF050M3	PULLEY, GEAR, 3/8P, 10T, 14MM
45	3	SSFC95032	SCREW, FLAT ALLEN CAP 10-24X1/

Item	QTY	Part Number	Description
46	3	SSFC98040	SCREW, FLAT ALLEN CAP 10-32X5/
47	10	SSSC01048	SCREW, SOCKET CAP 1/4-20X3/4
48	1	3200129	BLOCK, PLATE RUB MNT 3200PC
49	13	SSBC70016	SCREW, BUTTON CAP 4-40X1/4
50	5	SSSC98040	SCREW, SOCKET CAP 10-32X5/8
51	14	SSSC01064	SCREW, SOCKET CAP 1/4-20X1
52	4	SSSC95048	SCREW, SOCKET CAP 10-24X3/4
53	4	SSSC98032	SCREW, SOCKET CAP 10-32X1/2
54	13	WWS14	WASHER, INTERNAL TOOTH, 4
55	15	WWL10	WASHER, LOCK, 10
56	7	WWS10	WASHER, FLAT, SAE, 10
57	6	WWS1/4	WASHER, FLAT, SAE, 1/4
58	4	SSSCM5X14	SCREW, SOCKET CAP M5-0.8X14
59	1	AA FCT-11	CLEVIS, AIR CYLINDER 5/16-24 T
60	1	4059-DC1500A	MOTOR & CONTROLLER ONLY NO ACC
61	1	3200083	MOUNT, CYLINDER PIVOT 3200PB
62	1	SSSC98080	SCREW, SOCKET CAP 10-32X1-1/4
63	2	SSSC95096	SCREW, SOCKET CAP 10-24X1-1/2
64	1	EENC256	ENCODER, SBUS, 256, 1/4
65	1	33004061	COVER, ENCODER 3300
66	1	33004080	BRKT, ENCODER SUPPORT 3300
67	1	SSAS016064	SCREW, ALLEN SHOULDER 1/4X1, 1
68	2	SSAS024040	SCREW, ALLEN SHOULDER 3/8X5/8,
69	1	33004062	PLATE, MAIN MOUNTING 3300
70	2	NUJ3/8-24	NUT, JAM, 3/8-24
71	2	WWF8	WASHER, FLAT, 8
72	4	BBS8703-88	BEARING, BALL, .75IDX1.75OD EX
73	2	AA EHSKQ	SWITCH, HALL EFFECT W/QUICK CO
74	2	AA FD35000	BAND, UNIVERSAL, AA EHSKQ FOR S
75	1	33004063	SPACER 3300
76	1	273-4-503A	WASHER, LEATHER 3/8 IDX1 OD, 5
77	1	SSSS98012B	SCREW, SKT SET, BRASS TIP 10-3
78	3	SSSC10080	SCREW, SOCKET CAP 5/16-18X 1-1
79	1	NUJ7/16-20	NUT, JAM, 7/16-20
80	3	WWS5/16	WASHER, FLAT, SAE, 5/16 .70 OD
81	4	SSSC95032	SCREW, SOCKET CAP 10-24X1/2
82	1	BBTRA1220	WASHER, THRUST, STEEL 3/4 .75I
83	1	3200102	MOUNT, CYLINDER, 3200P GUILLOT
84	1	SSSC40080	SCREW, SOCKET CAP 7/16-20X1-1/
85	1	3200128	MOUNT, PIVOT BRKT 32004000PC
86	2	SSSC98064	SCREW, SOCKET CAP 10-32X1
87	2	SSPS90024	SCREW, PAN HD SLOTTED 8-32X3/8
88	4	SSPS98032	SCREW, PAN HD SLOTTED 10-32X1/
89	2	3200343	GEAR, CYCLOID, ASM, 14 TH

# 32007700P Roll Holder Assembly

AAC Drawing Number 192088A Rev 1

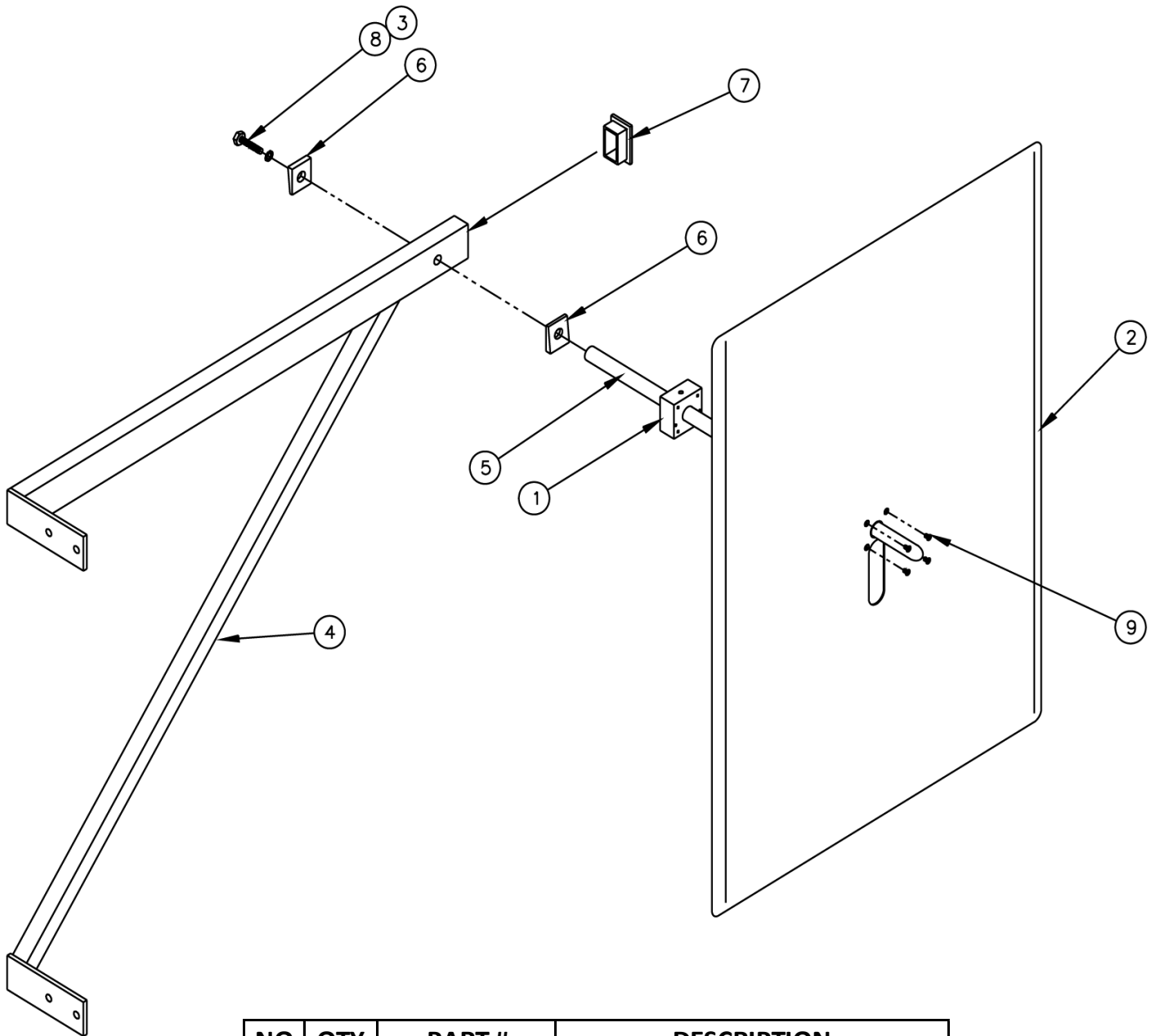

NO	QTY	PART #	DESCRIPTION
1	1	1961-253A	HUB, UNWIND
2	1	784B-2436	ALU PLATE
3	1	WWL3/8	LOCK WASHER
4	1	32007704	FRAME, ROLL HOLD
5	1	33008202	ROD, 3/4X21
6	2	WWSQ080B	WASHER, SQ, STRUCT
7	1	MM132-1496	END CAP
8	1	SSH25160	SCREW, HEX CAP 3/8-16 X 2-1/2
9	4	SSBC80032	SCREW, BUTTON CAP 6-32 X 1/2

# 3200213 Control System

AAC Drawing Number 3200213 Rev 5

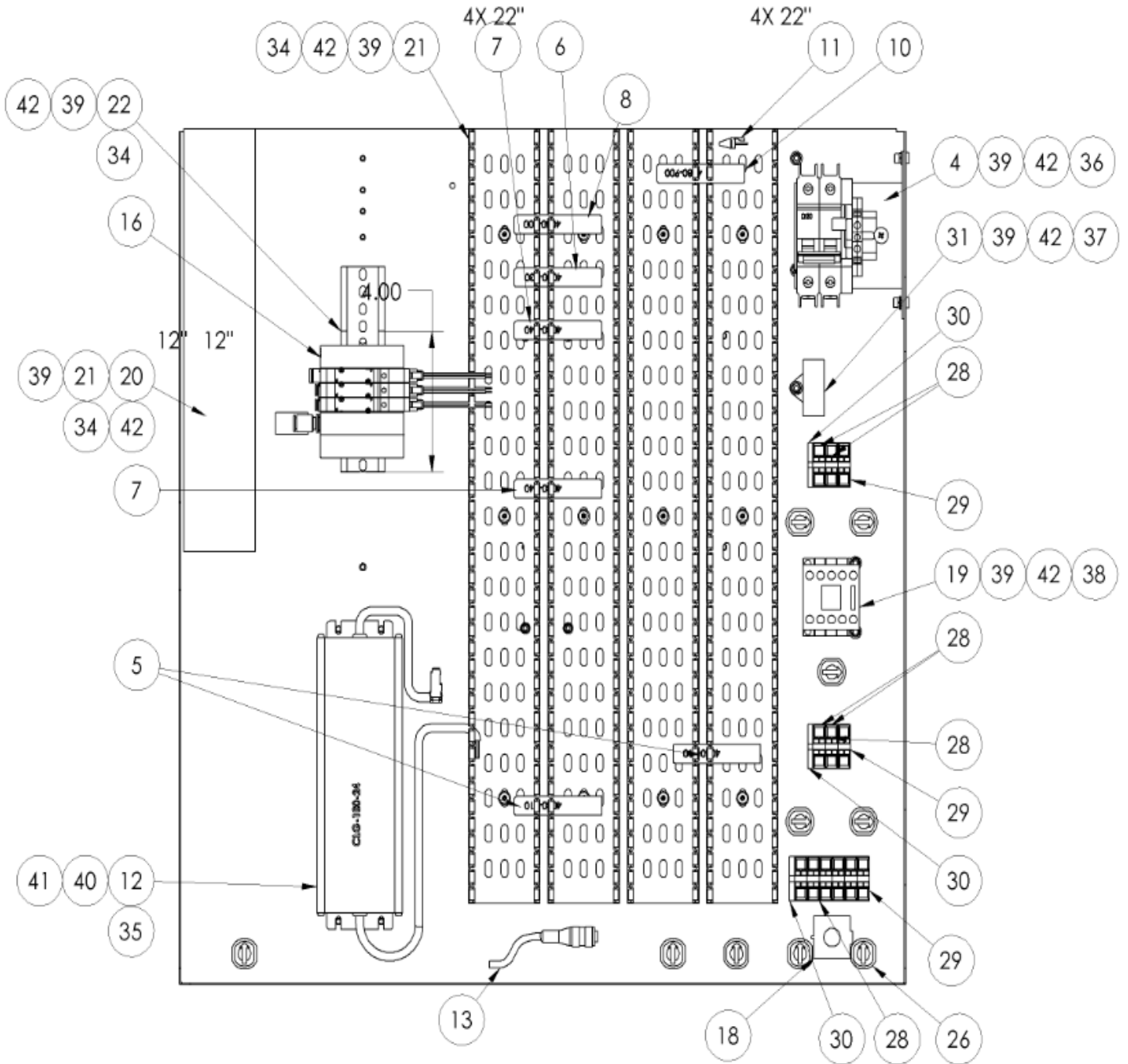

3200213 parts list

ITEM	QTY.	PART NUMBER	DESCRIPTION
1	2	12788-509A	JUMPER,OUTPUT,RESISTOR
2	1	32009001A	PANEL,CONTROL
3	1	3200PB1E-WD1	DIAGRAM, WIRING, W/4080-200
4	1	40-320	AC POWER DISCONNECT ASSY
5	2	4080-110	MODULE,QUAD INPUT
6	1	4080-130	MODULE,QUAD OPTO-ISO
7	2	4080-140	MODULE,QUAD OUTPUT
8	1	4080-200	MODULE,AIR PRESSURE
9	1	4080-4130	CABLE, BUS ASSEMBLY
10	1	4080-900	SBUS MODULE, USB GATEWAY, INTERFACE
11	1	4080-940	MODULE,TERMINATOR
12	1	4080-990B	POWER SUPPLY, SBUS,
13	1	4080101-103	CABLE,AE PLUG,8'LONG
14	*1	4082000-24	CABLE, SPLITTER, EXTENSION, 2P FM
15	*1	4082001-84	CABLE, EXTENSION, 2P FM, 2P M, 7'
16	1	AAE3200-3	SOLENOID ASSY,4 STA
17	*10.	EE16-3C2406	CABLE,3 COND,16AWG,300V
18	1	EE64151B	FERRITE CORE,SPLIT,CABLE
19	1	EECA491024	CONTACTOR, MINI, 240V
20	100"	EEDC2X2	COVER,WIRE DUCT
21	100"	EEDF2X2	DUCT,WIRE,2X2, MOD
22	4"	EETS35X7.5A	DIN RAIL-AMERICAN
23	*1	EEUSBAMUSBCM6	USB-A M TO USB-C CABLE M, 6'
24	3	FF100F2202	CONNECTOR,2 PIN,RED
25	*3	FF100F2403	CONNECTOR,3 PIN,24GA,BLK
26	11	FF1724	STRAIN RELIEF
27	21 FT	FF19511	CABLE, 3 COND, 14 AWG, SJTOW
28	8	FF264-341	TERMBLK,WAGO,TOP,DUAL,GRY
29	4	FF264-347	TERMBLK,WAGO,TOP,DUAL,GRN
30	3	FF264-371	TERMBLK,WAGO,TOP,END
31	1	FFRAV781BW	MODULE, TVS, 240 VAC
32	3	FFSC10002	COVER,STRAIN RELIEF
33	3	FFSC10003	COVER,STRAIN RELIEF,3
34	17	SSBC90024	8-32X3/8 BUTTON CAP
35	4	SSSC80024	6-32 X 3/8 SOC CAP SC
36	2	SSSC90016	#8-32 X 1/4 SOC CAP SC
37	1	SSSC90024	#8-32 X 3/8 SOC CAP SC
38	4	SSSC90032	#8-32 X 1/2 SOC CAP SC
39	24	WWF8	WASHER, FLAT, #8
40	4	WWFS6	WASHER, FLAT, #6
41	4	WWL6	WASHER,LOCK,#6
42	24	WWL8	WASHER,LOCK,#8

# 3200PB1E-PD1 Pneumatic Diagram

AAC Drawing 125458D Rev 0

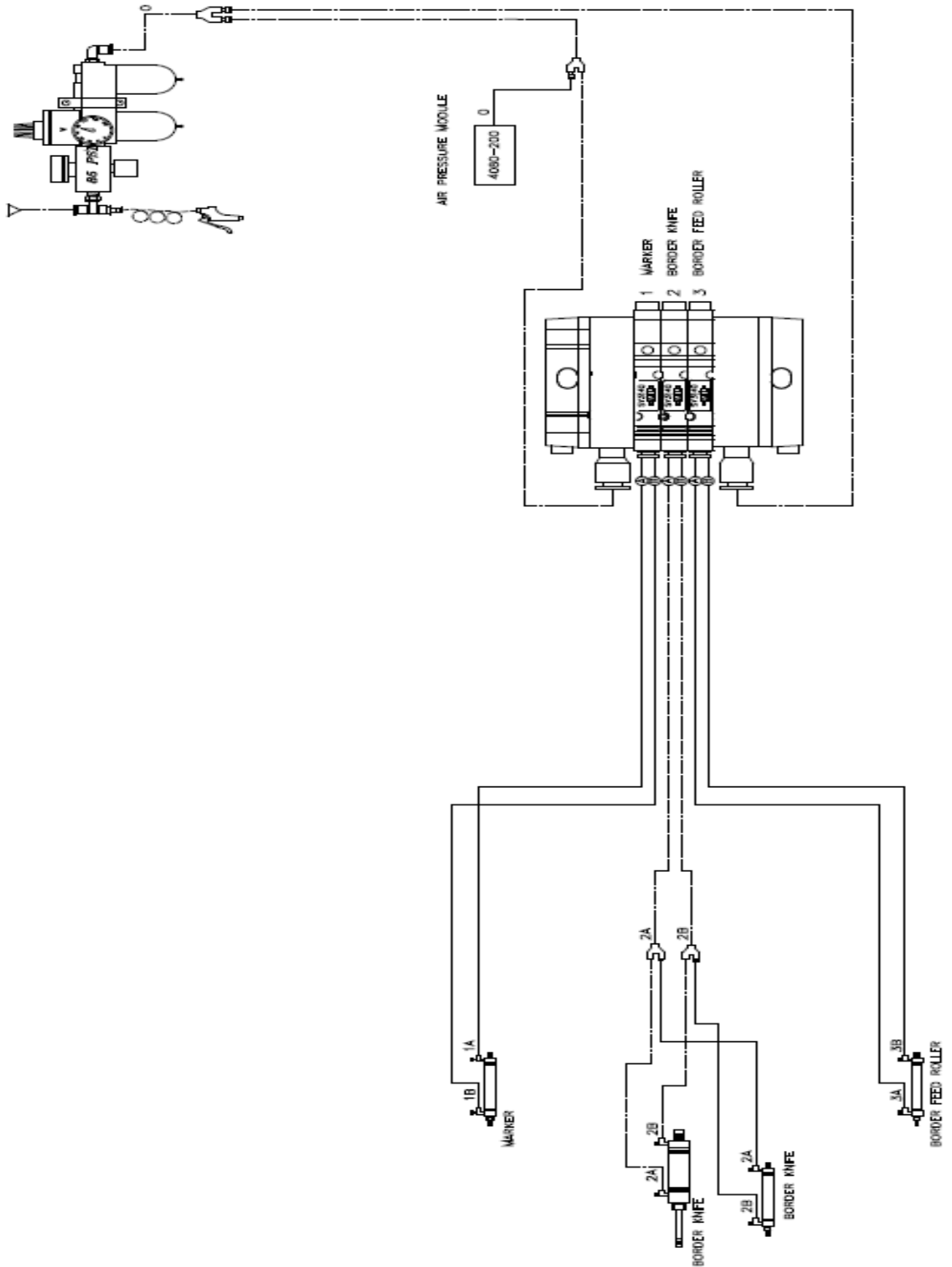



# Atlanta Attachment Company (AAC) Statement of Warranty

## Manufactured Products

Atlanta Attachment Company warrants manufactured products to be free from defects in material and workmanship for a period of eight hundred (800) hours of operation or one hundred (100) days whichever comes first. Atlanta Attachment Company warrants all electrical components of the Serial Bus System to be free from defects in material or workmanship for a period of thirty six (36) months.

## Terms and Conditions:

- AAC Limited Warranty becomes effective on the date of shipment.
- AAC Warranty claims may be made by telephone, letter, fax or e-mail. All verbal claims must be confirmed in writing.
- AAC reserves the right to require the return of all claimed defective parts with a completed warranty claim form.
- AAC will, at its option, repair or replace the defective machine and parts upon return to AAC.
- AAC reserves the right to make the final decision on all warranty coverage questions.
- AAC warranty periods as stated are for eight hundred (800) hours or one hundred (100) days whichever comes first.
- AAC guarantees satisfactory operation of the machines on the basis of generally accepted industry standards, contingent upon proper application, installation and maintenance.
- AAC Limited Warranty may not be changed or modified and is not subject to any other warranty expressed or implied by any other agent, dealer, or distributor unless approved in writing by AAC in advance of any claim being filed.

## What Is Covered

- Electrical components that are not included within the Serial Bus System that fail due to defects in material or workmanship, which are manufactured by AAC are covered for a period of eight hundred (800) hours.
- Mechanical parts or components that fail due to defects in material or workmanship, which are manufactured by AAC.
- Purchased items (sewing heads, motors, etc.) will be covered by the manufacturers (OEM) warranty.
- AAC will assist in the procurement and handling of the manufacturers (OEM) claim.

## What Is Not Covered

- Parts that fail due to improper usage, lack of proper maintenance, lubrication and/or modification.
- Damages caused by; improper freight handling, accidents, fire and issues resulting from unauthorized service and/or personnel, improper electrical, plumbing connections.
- Normal wear of machine and parts such as Conveyor belts, "O" rings, gauge parts, cutters, needles, etc.
- Machine adjustments related to sewing applications and/or general machine operation.
- Charges for field service.
- Loss of time, potential revenue, and/or profits.
- Personal injury and/or property damage resulting from the operation of this equipment.

# Declaración de Garantía

## Productos Manufacturados

Atlanta Attachment Company garantiza que los productos de fabricación son libres de defectos de material y de mano de obra durante un periodo de ochocientos (800) horas de operación o cien (100) días cual llegue primero. Atlanta Attachment Company garantiza que todos los componentes del Serial bus son libres de defectos de material y de mano de obra durante un periodo de treinta y seis (36) meses.

## Términos y Condiciones:

- La Garantía Limitada de AAC entra en efecto el día de transporte.
- Reclamos de la Garantía de AAC pueden ser realizados por teléfono, carta, fax o correo electrónico. Todo reclamo verbal tiene que ser confirmado vía escrito.
- AAC reserva el derecho para exigir el retorno de cada pieza defectuosa con un formulario de reclamo de garantía.
- AAC va, según su criterio, reparar o reemplazar las máquinas o piezas defectuosas devueltas para AAC.
- AAC reserva el derecho para tomar la decisión final sobre toda cuestión de garantía.
- Las garantías de AAC tiene una validez de ochocientas (800) horas o cien (100) días cual llega primero.
- AAC garantiza la operación satisfactoria de sus máquinas en base de las normas aceptadas de la industria siempre y cuando se instale use y mantenga de forma apropiada.
- La garantía de AAC no puede ser cambiado o modificado y no está sujeto a cualquier otra garantía implicado por otro agente o distribuidor menos al menos que sea autorizado por AAC antes de cualquier reclamo.

## Lo Que Está Garantizado

- Componentes eléctricos que no están incluidos dentro del sistema Serial Bus que fallen por defectos de materiales o de fabricación que han sido manufacturados por AAC son garantizados por un periodo de ochocientas (800) horas.
- Componentes mecánicos que fallen por defectos de materiales o de fabricación que han sido manufacturados por AAC son garantizados por un periodo de ochocientas (800) horas.
- Componentes comprados (Motores, Cabezales, ) son protegidos debajo de la garantía del fabricante.
- AAC asistirá con el manejo de todo reclamo de garantía bajo la garantía del fabricante.

## Lo Que No Está Garantizado

- Falla de repuestos al raíz de uso incorrecto, falta de mantenimiento, lubricación o modificación.
- Daños ocurridos a raíz de mal transporte, accidentes, incendios o cualquier daño como resultado de servicio por personas no autorizados o instalaciones incorrectas de conexiones eléctricas o neumáticas.
- Desgaste normal de piezas como correas, anillos de goma, cuchillas, agujas, etc.
- Ajustes de la máquina en relación a las aplicaciones de costura y/o la operación en general de la máquina.
- Gastos de Reparaciones fuera de las instalaciones de AAC
- Pérdida de tiempo, ingresos potenciales, y/o ganancias.
- Daños personales y/o daños a la propiedad como resultado de la operación de este equipo.



**Atlanta Attachment Company**  
362 Industrial Park Drive  
Lawrenceville, GA 30046  
770-963-7369  
[www.atlatt.com](http://www.atlatt.com)

**Printed in the USA**