



Model

1315B

Revision 0

Updated April 24, 2023

Technical Manual & Parts Lists

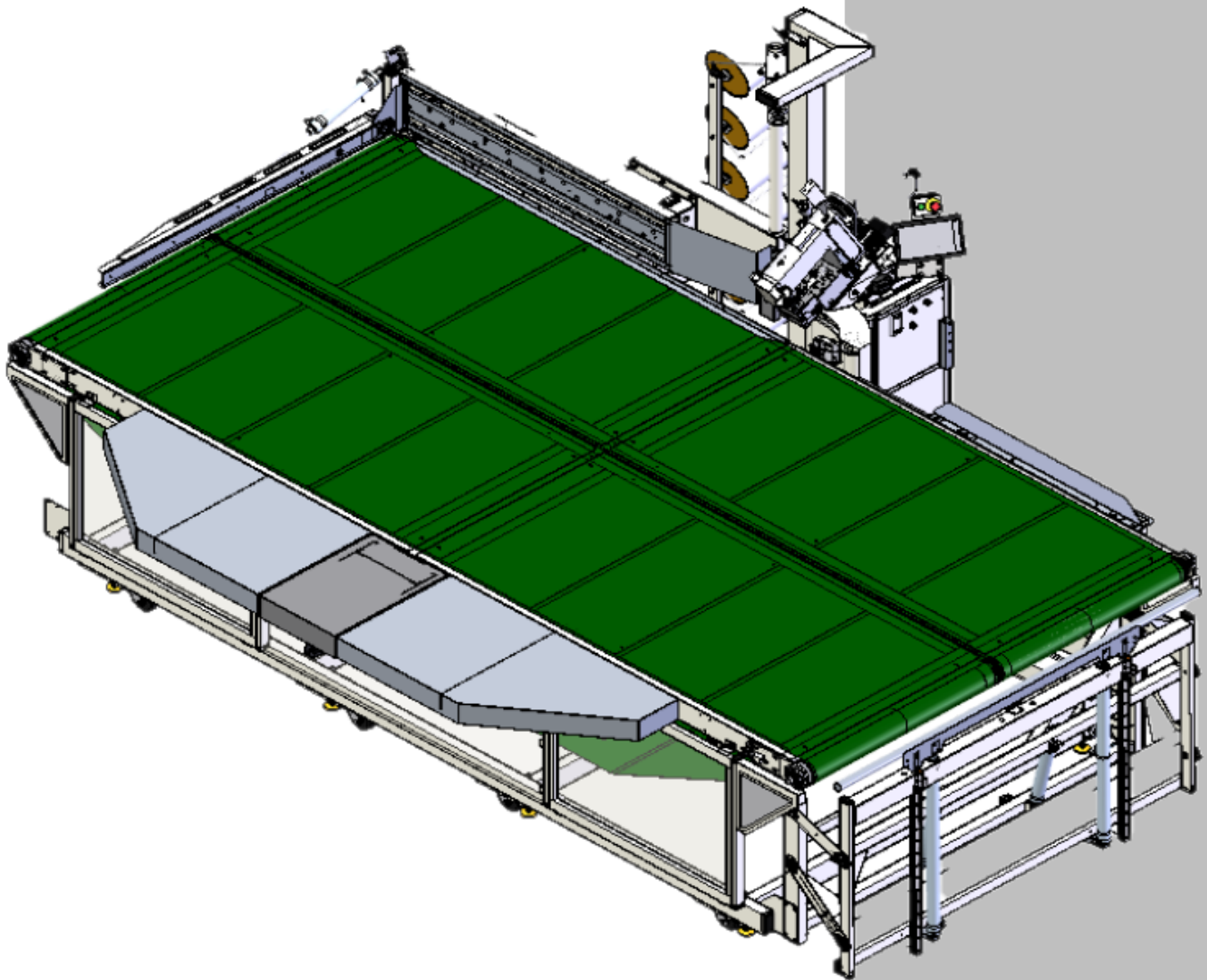

Atlanta Attachment Company

362 Industrial Park Drive

Lawrenceville, GA 30046

770-963-7369 • www.atlatt.com

ATLANTA ATTACHMENT COMPANY, INC.

Confidential and Proprietary Information

The materials contained herein are confidential and proprietary information of Atlanta Attachment Company. In addition to any confidentiality and non-disclosure obligations that currently exist between you and Atlanta Attachment Company, your use of these materials serves as an acknowledgment of the confidential and proprietary nature of these materials and your duty not to make any unauthorized use or disclosure of these materials.

All materials contained herein are additionally protected by United States Copyright law and may not be used, disclosed, reproduced, distributed, published or sold without the express written consent of Atlanta Attachment Company, which consent may be withheld in Atlanta Attachment Company's sole discretion. You may not alter or remove any copyright, trademark or other notice from copies of these materials.

IMPORTANT
It is important to read and understand the information contained within this manual before attempting to operate the machine. Atlanta Attachment Co., Inc. shall not be held liable for damage resulting from misuse of the information presented within, and reserves the right to change the information contained within, without prior notification.

Contents

Important Safety Instruction	1
Liability	2
Safety Equipment on the Machines	3
Protective Eyewear	4
Important Notices.....	5
Maintenance	7
Repair	8
A Word to the End User.....	9
Safety Precautions.....	9
Component Identification	10
General Machine Data	11
Electrical & Pneumatic Specifications.....	11
Foot Prints:.....	11
Basic Machine Operation.....	12
Operational Path of Screens.....	15
Efka Control Box	20
General Machine Maintenance	21
Daily.....	21
Weekly	21
Monthly.....	21
Electric Eye Sensor Adjustment	22
Reflective Tape Maintenance	22
Efka Parameter Settings (Sewing Head Motor).....	23
Programming Instructions.....	23
To Perform Master Reset of Parameters.....	23
Speed Setting Controls.....	25
Side Sewing Speed Controls.....	25
Corner Sewing Speed Controls.....	25
Auxiliary Sewing Speed Controls.....	25
Conveyor Belt Tracking Instructions.....	26
Servicing the Sew Head	29
Installation.....	29
Lubrication	30
Caution:.....	30
To Oil the Arm Shaft	30
To Oil the Bed Shaft	30

Other Oiling Points	30
Caution:.....	30
Setting the Needle	31
Threading the Machine	32
Tension.....	33
Needle Thread Tension	33
Looper Thread Tension.....	33
Pressure	33
Presser Foot Pressure	33
Alternating Pressers	33
Alternating Presser with Pneumatic Pressure Control	34
Upper Feed Roll Pressure	34
Stitch Length.....	34
Machine with Puller Feed	35
Presser Bar Lift	35
Machines with Alternating Pressers.....	36
Setting the Height of Feed Bar.....	37
Centralizing the Feed Dog	37
Setting the Height of the Feed Dog.....	37
Timing the Feed Lift Eccentric	38
Needle Bar Positioning	38
Positioning the Loop Deflectors	38
Setting the Distance from the Looper to the Needle.....	39
Sidewise Setting.....	39
Lengthwise Setting & Setting the Height of the Needle Bar	39
Timing Looper Driving Crank	40
Setting the Needle Guards	40
Positioning Spreader	41
Sidewise and Height Setting	41
Changing Movement of Spreader	41
Adjusting Needle Thread Tension Releaser	42
Adjusting Looper Thread Take-Up.....	42
Notes :	43
AAC 300UX6 Assembly Drawings & Parts Lists.....	44
Upper Shaft Assembly	46
Front Assembly Sewing Arm.....	48
External Parts Sewing Arm #1.....	50

Lower Shaft Assembly.....	52
Front Assembly Sewing Bed	54
Cross Shaft in Sewing Bed	56
External Parts Sewing Arm #2.....	58
External Parts Sewing Arm #3.....	60
External Parts Sewing Arm #4.....	62
External Parts Sewing Arm #5.....	64
Assembly Drawings & Parts Lists	66
11315B Auto Tape Edge Machine.....	67
1315050 Rotate Arm Assembly	74
1315030 Backstop Assembly	76
1315100 Sew Head Assembly	78
1315115 Arm Gearbox Assembly	80
1315435 Limit Switch Assembly.....	82
1315245 Control Box. Electrical Assembly	83
1315300 Console Assembly	86
1315200 Column Assembly	88
1315327 Lift Platform Assembly.....	90
1315060 Foot Pedal Assembly	92
1315400 Flipper Assembly	93
1315095 Pilot Valve Assembly.....	97
1315430 Pneumatic Panel.....	98
1315450 Tape Guide Assembly	100
1315479 Air Jet Assembly; (Right Side).....	101
1315483 Air Jet Assembly; (Left Side)	102
1315498 Push Plate Assembly.....	103
1315502 Table Assembly	105
1315575 Tape Roll Holder.....	109
1315595 Head Pusher Assembly	110
1315603 Sensor Bracket Assembly	111
1315A-PD Pneumatic Diagram	112
1315B-WD Wiring Diagram.....	113
1315B-WD1 Wiring Diagram.....	114

Important Safety Instruction



This part of the Instruction Material is provided for the safe use of your equipment. It contains important information to help work safely with the unit and describes the dangers inherent in machinery. Some of these dangers are obvious, while others are less evident.

Mandatory Information

All persons operating and/or working on the 1959 Automatic Handle Workstation should read and understand all parts of the Safety Instructions. This applies, in particular, for persons who only operate and/or work on the unit occasionally (e.g. for maintenance and repair). Persons who have difficulty reading must receive particularly thorough instruction.

Scope of the Instruction Material

- The Instruction Material comprises:
- Safety information
- Operator Instructions
- Electrical and Pneumatic diagrams

And may also include.

- A list of recommended spare parts
- Instruction Manual(s) for components made by other manufacturers.
- The layout and installation diagram containing information for installation.

Intended Use

Our machines are designed and built in line with the state of the art and the accepted safety rules. However, all machines may endanger the life and limb of their users and/or third parties and be damaged or cause damage to other property, particularly if they are operated incorrectly or used for purposes other than those specified in the Instruction Manual.

Exclusion of Misuse



Non-conforming uses include, for example, using the equipment for something other than it was designed for, as well as operation without duly installed safety equipment. The risk rests exclusively with the end user.

Conforming use of the machine includes compliance with the technical data, information, and regulations in all parts of the complete Instruction Material, as well as compliance with the maintenance regulations. All local safety and accident prevention regulations must also be observed.

Liability

The machine should only be operated when in perfect working order, with due regard for safety and the potential dangers, as well as in accordance with the Instruction Material. Faults and malfunctions capable of impairing safety should be remedied immediately. We cannot accept any liability for personal injury or property damage due to operator errors or non-compliance with the safety instructions contained in this booklet. The risk rests exclusively with the end user.

The Instruction Material should always be kept near the machine so that it is accessible to all concerned.

The local, general, statutory, and other binding regulations on accident prevention and environmental protection must also be observed in addition to the Instruction Material. The operating staff must be instructed accordingly. This obligation also includes the handling of dangerous substances and provision/use of personal protective equipment.

The Instruction Material should be supplemented by instructions, including supervisory and notification duties with due regard for special operational features, such as the organization of work, work sequences, the personnel deployed, etc.

The personnel's awareness of the dangers and compliance with the safety regulations should be checked at irregular intervals.

Choice and Qualification of Personnel

Ensure that work on the machine is only carried out by reliable persons who have been appropriately trained for such work - either within the company, by our field staff or at our office - and who have not only been duly appointed and authorized but are also fully familiar with the local regulations. Work on the machine should only be carried out by skilled personnel, under the management and supervision of a duly qualified engineer.

This not only applies when the machine is used for production, but also for special work associated with its operation (start-up and maintenance), especially when it concerns work on the hydraulic or electrical systems, as well as on the software/serial bus system.

Training

Everyone working on or with the machine should be duly trained and informed about the correct use of the safety equipment, the foreseeable dangers which may arise during operation of the machine and the safety precautions to be taken. In addition, the personnel should be instructed to check all safety mechanisms at regular intervals.

Responsibilities

Clearly define exactly who is responsible for operating, setting-up, servicing and repairing the machine. Define the responsibilities of the machine operator and authorize him to refuse any instructions by third parties if they run contrary to the machine's safety. This applies for the operators of machines linked to other equipment. Persons receiving training of any kind may only work on or with the machine under the constant supervision of an experienced operator. Note the minimum age limits permitted by law.

A Word to the Operator

The greatest danger inherent in our machines: is that of fingers, hands or loose clothing being drawn into a machine by live, coasting or rotating tools or assemblies or of being cut by sharp tools or burned by hot elements.

ALWAYS BE CONSCIOUS OF THESE DANGERS!

Safety Equipment on the Machines



All machines are delivered with safety equipment, which shall not be removed or bypassed during operation.

The correct functioning of safety equipment on machines and systems should be checked every day and before every new shift starts, after maintenance and repair work, when starting up for the first time and when restarting (e.g. after prolonged shutdowns).

If safety equipment must be dismantled for setting-up, maintenance or repair work, such safety equipment shall be replaced and checked immediately upon completing the maintenance or repair work. All protective mechanisms shall be fitted and fully operational whenever the machine is at a standstill or if it has been shut down for a longer period.

Damage

If any changes capable of impairing safety are observed in the machine or its mode of operation, such as malfunctions, faults or changes in the machine or tools, appropriate steps must be taken immediately, the machine switched off and a proper lockout tagout procedure followed. The machine should be examined for obvious damage and defects at least once per shift. Damage found shall be immediately remedied by a duly authorized person before resuming operation of machine.

The machine should only be operated when in perfect working order and when all protective mechanisms and safety equipment, such as detachable protective mechanisms, emergency STOP systems, etc. are in place and operational.

Faults or Errors

The machine must be switched off and all moving or rotating parts allowed to come to a standstill and secured against accidental restart before starting to remedy any faults or errors.

Signs on the Machine

Safety and danger signs on the machine should be observed and checked at regular intervals to ensure that they are complete and undamaged. They should be always clearly visible and legible. Clothing, Jewelry, Protective Equipment, Long loose hair, loose-fitting clothes, gloves and jewelry, including rings, should be avoided in order to avoid injuries due to being caught, drawn in and wound up inside the machine.

Protective Eyewear

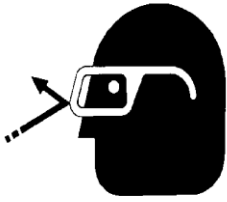

Protective eyewear that has been tested by the local authorities should be worn whenever there is a possibility of loose or flying objects or particles such as when cleaning the machine with compressed air.

Tools

Always count the number of tools in your possession before starting work on the machine. This will allow you to check that no tools have been left behind inside the machine. Never leave a tool in the machine while working.

Oils, Lubricants, Chemicals

Note the applicable safety regulations for the product used.

No Smoking, Fire, Explosion Hazard

Smoking and open flame (e.g. welding work) should be prohibited in the production area due to the risk of fire and explosions.

Workplace

A clear working area without any obstructions whatsoever is essential for safe operation of the machine. The floor should be level and clean, without any waste.

The workplace should be well lit, either by the general lighting or by local lights.

Emergency STOP

The emergency STOP buttons bring all machine movements to a standstill. Make sure you know exactly where they are located and how they work. Try them out. Always ensure easy access to the nearest emergency STOP button while working on the machine.

First Aid

1. Keep calm even when injured.
2. Clear the operator from the danger zone. The decision of what to do and whether to seek additional assistance rests entirely with you, particularly if someone has been trapped.
3. Give First Aid. Special courses are offered by such organizations as the employers' liability insurance association. Your colleagues should be able to rely on you and vice versa.
4. Call an ambulance. Do you know the telephone numbers for the ambulance service, police, and fire service?

Important Notices

Reporting and Fighting Fires

Read the instructions posted in the factory about reporting fires and the emergency exits. Make sure you know exactly where the fire extinguishers and sprinkler systems are located and how they are operated. Pass on the corresponding information to the firemen when they arrive. Ensure there are enough signs to avoid fire hazards.

The following fire extinguishers may be used:

- Dry powder extinguishers, ABC fire-extinguishing powder.
- Carbon dioxide fire extinguishers to DIN 14461 for electronic components. Great care must be exercised when using carbon dioxide fire extinguishers in confined, badly ventilated rooms (see DIN 14406 and 14270).

Isolate the machine from the power supply if a fire breaks out. Do not use water on burning electrical parts until it is certain that they have been completely disconnected from the power supply. Burning oils, lubricants, plastics, and coatings on the machine can give off gases and vapors that may be harmful to your health.

A qualified person should be consulted to repair the damage after a fire.

Electrical Power Supply



Before undertaking any maintenance or repair work on the machine, switch off the electrical power to the machine at the main source and secure it with a padlock so that it cannot be switched on again without authorization.

In practice, this may mean that the technician, electrician, and operator all attach their own padlock to the master switch simultaneously so that they can carry out their work safely. Locking extension plates should be available for multiple locks if required. The primary purpose for a lockout/tagout procedure is to protect workers from injury caused by unexpected energizing or start-up of equipment.

Energy sources (electrical/pneumatic/hydraulic, etc.) for the equipment shall be turned off or disconnected and the switches locked or labeled with a warning tag. It is the responsibility of the employer to establish control procedures. Follow lockout/tagout procedures before, setup and/or any service or maintenance work is performed, including lubrication, cleaning, or clearance of jams.

Caution: The machine is still not completely de-energized even when the master switch is off.

- Electricity - The machine is always isolated from the electrical power supply whenever the master switch has been switched off. However, this does not apply for the power supply in the control cabinet, nor for equipment that does not draw its power via the master switch.
- Pneumatic / hydraulic energy - Almost all our machines carry compressed air. In addition to switching off the master switch, the air supply must also be disconnected, and the machine checked to ensure it is depressurized before starting any work on the machine; otherwise the machine may execute uncontrolled movements.

- Kinetic energy - Note that some motors or spindles, for example, may continue to run or coast run on after being switched off.
- Potential energy - Individual assemblies may need to be secured if necessary for repair work.

Delivery of the Machine/Packaging

Note any markings on the packaging, such as weights, lifting points and special information. Avoid temperature fluctuations. Condensation may damage the machine.

Transport Damage

The packaging and machine must immediately be examined for signs of damage in transit. Such damage must be reported to the shipper/transporter within the applicable time limits. Contact Atlanta Attachment Company and/or your transport insurer immediately, if signs of damage are visible. Never operate a damaged machine.

Interim Storage

If the machine has to be stored temporarily, it must be oiled or greased and stored in a dry place where it is protected from the weather in order to avoid damage. A corrosion-inhibiting coating should be applied if the machine has to be stored for a longer period of time and additional precautions taken to avoid corrosion.

Transporting the Machine

Disconnect the machine from all external connections and secure any loose assemblies or parts. Never step under a suspended load. When transporting the machine or assemblies in a crate, ensure that the ropes or arms of a forklift truck are positioned as close to the edge of the crate as possible. The center of gravity is not necessarily in the middle of the crate. Note the accident prevention regulations, safety instructions and local regulations governing transport of the machine and its assemblies.

Only use suitable transport vehicles, hoisting gear and load suspension devices that are in perfect working order and of adequate carrying capacity. Transport should only be entrusted to duly qualified personnel.

Never allow the straps to rest against the machine enclosure and never push or pull sensitive parts of the machine. Ensure that the load is always properly secured. Before or immediately after loading the machine, secure it properly and affix corresponding warnings.

All transport guards and lifting devices must be removed before the machine is started up again. Any parts that are to be removed for transport must be carefully refitted and secured before the machine is started up again.

Workplace Environment

Our machines are designed for use in enclosed rooms: Permissible ambient temperature approx. 5 - 40 °C (40 - 104 °F). Malfunctions of the control systems and uncontrolled machine movements may occur at temperatures outside this range.

Protect against climatic influences, such as electrostatic charges, lightning strikes, hail, storm damage, high humidity, salinity of the air in coastal regions.

Protect against influences from the surroundings: no structure-borne vibrations, no grinding dust, or chemical vapors.

Protect against unauthorized access.

Ensure that the machine and accessories are set up in a stable position.

Ensure easy access for operation and maintenance (Instruction Manual and layout diagram); also verify that the floor is strong enough to carry the weight of the machine.

Local Regulations

Particular attention must be paid to local and statutory regulations, etc. when installing machines and the plant (e.g. with regard to the specified escape routes). Note the safety zones in relation to adjacent machines.

Maintenance

General Safety Instructions

The machine shall be switched off, come to a standstill, and be secured so that it cannot be switched on again inadvertently before starting any maintenance work whatsoever. Use proper lockout/tagout procedures to secure the machine against inadvertent startup.

Remove any oil, grease, dirt and waste from the machine, particularly from the connections and screws, when starting the maintenance and/or repair work. Do not use any corrosive-cleaning agents. Use lint-free rags.

Retighten all screw connections that must be loosened for the maintenance and repair work. Any safety mechanisms that must be dismantled for setting-up, maintenance or repair purposes must be refitted and checked immediately after completing the work.

Maintenance, Care, Adjustment

The activities and intervals specified in the Instruction Manual for carrying out adjustments, maintenance and inspections must be observed, and parts replaced as specified.

All hydraulic and pneumatic lines should be examined for leaks, loose connections, rubbing and damage whenever the machine is serviced. Any defects found must be remedied immediately.

Waste, Disassembly, Disposal

Waste products should be cleared from the machine as soon as possible as not to create a fire hazard. Ensure that fuels and operating lubricants, as well as replacement parts are disposed of in a safe and ecologically acceptable manner. Note the local regulations on pollution control.

When scrapping (disassembling) the machine and its assemblies, ensure that these materials are disposed of safely. Either commission a specialist company familiar with the local regulations or note the local regulations when disposing of these materials yourself. Materials should be sorted properly.

Repair

Replacement Parts

We cannot accept any liability whatsoever for damage due to the use of parts made by other manufacturers or due to unqualified repair or modification of the machine.

Repair, Electrical

The power supply must be switched off (master switch off) and secured so that it cannot be switched on again inadvertently before starting any work on live parts.

Those parts of the machine and plant on which inspection, maintenance or repair work is to be carried out must be isolated from the power supply, if specified. The isolated parts must first be checked to determine that they are truly de-energized before being grounded and short-circuited. Adjacent live parts must also be isolated.

The protective measures implemented (e.g. grounding resistance) must be tested before restarting the machine after all assembly or repair work on electric parts.

Signal generators (limit switches) and other electrical parts on the safety mechanisms must not be removed or bypassed. Only use original fuses or circuit overloads with the specified current rating. The machine must be switched off immediately if a fault develops in the electrical power supply.

The electrical equipment of our machines must be checked at regular intervals and any defects found must be remedied immediately.

If it is necessary to carry out work on live parts, a second person should be on hand to operate the emergency OFF switch or master switch with voltage release in the event of an emergency. The working area should be cordoned off and marked by a warning sign. Only use electrically insulated tools.

Ventilation/Hazardous Gases

It is the end user's responsibility to ensure adequate ventilation is provided to exhaust any and all noxious or hazardous gases that may be present in the working environment.

Hydraulic and Pneumatic Systems

Work on hydraulic or pneumatic equipment shall only be carried out by persons with training, knowledge and experience of hydraulic systems. Pressure lines shall be depressurized before starting any repair work.

General Liability

Liability for machine damage and personal injury is extinguished completely if any unauthorized conversions or modifications are undertaken. The machine must not be modified, enlarged, or converted in any way capable of affecting safety without the manufacturer's prior approval.

Starting Machine Movements

Read the Instruction Manual carefully to establish which keys and functions start machine movements.

A Word to the End User

The end user has sole responsibility to enforce the use of safety procedures and guards on the machine. Any other safety devices or procedures due to local regulations should be retrofitted in accordance to these regulations and/or the EC Directive on the safety of machines.

Operator's position must always be readily accessible. Escape routes must always be kept clear and safety areas should be identified.

Safety Precautions

Safety should be a constant concern for everyone. Always be careful when working with this equipment. While normal safety precautions were taken in the design and manufacture of this equipment, there are some potential safety hazards.

Everyone involved with the operation and maintenance of this equipment should read and follow the instructions in this manual.

Operate the equipment only as stated in this manual. Incorrect use could cause damage to the equipment or personal injury.

It is the owner's responsibility to make certain that the operator reads and understands this manual before operating this equipment. It is also the owner's responsibility to make certain that the operator is a qualified and physically able individual, properly trained in the operation of this equipment.

Specific safety warning decals are located on the equipment near the immediate areas of potential hazards. These decals should not be removed or obliterated. Replace them if they become non-readable.

- ALWAYS keep safety shields and covers in place, except for servicing.
- ALWAYS maintain a safe distance from people when operating.
- ALWAYS operate equipment in daylight or with adequate working lights.
- Follow daily and weekly checklists, making sure hoses are tightly secured and bolts are tightened.
- ALWAYS watch and avoid holes or deep depressions.
- ALWAYS wear adequate eye protection when servicing the hydraulic system and battery.
- NEVER operate a poorly maintained machine.
- NEVER allow persons to operate this machine without proper instruction.
- NEVER put hands or feet under any part of the machine while it is running.
- NEVER attempt to make any adjustments or repairs to the machine while running. Repairs or maintenance should be performed by trained personnel only.
- NEVER work under the machine unless it is safely supported with adequate mechanical stands, blocks or a hoist and blocks.
- NEVER touch hot parts of machine.

Component Identification

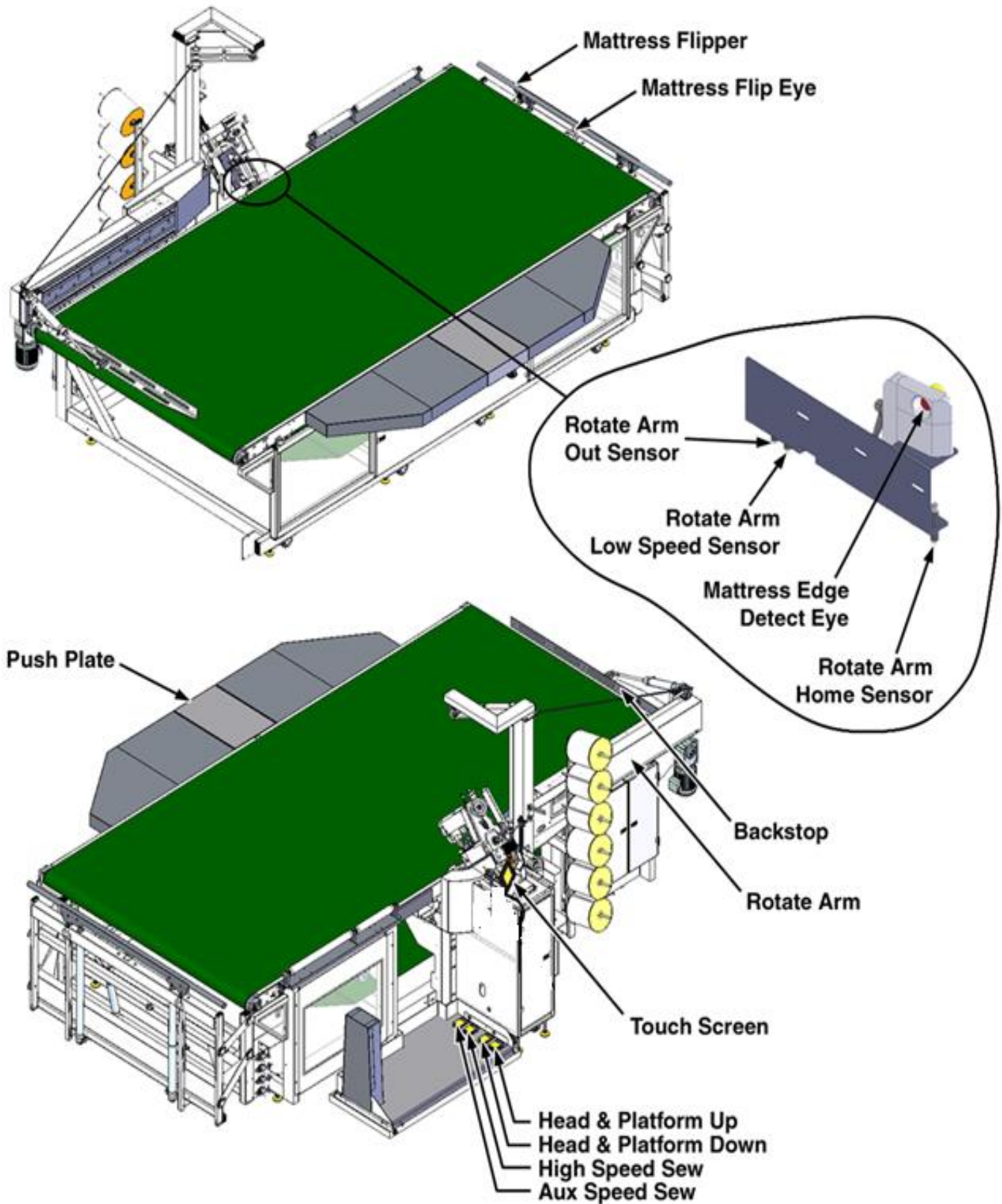

General Machine Data

Electrical & Pneumatic Specifications

Electrical: 220 VAC, 5amp, 50/60 Hz Single Phase
 Pneumatic: Main Air - 80 PSI, 5 SCFM avg. (3/8" supply line)
 Pneumatic Component Belt Tension - 40-50 PSI

Sewing Head: AAC 300UX5
 Sewing Speed: 3000 RPM
 Needle (Standard): SN62X8524
 Stitch Density: 5-6 SPI

Foot Prints:

Machine 180" inches long x 134" inches wide

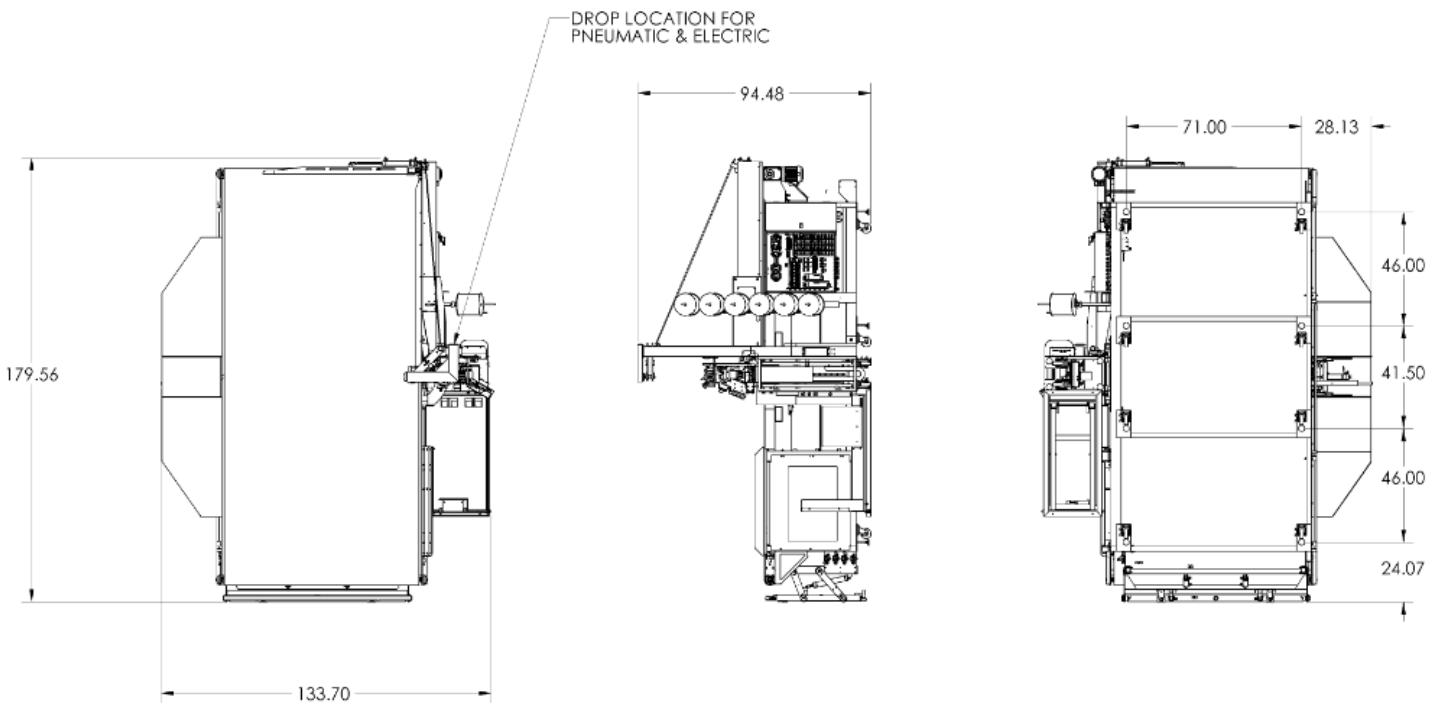

Basic Machine Operation

The operator loads a mattress and covers the Mattress Edge Detect Eye. The machine will not sew unless the eye is covered.

The Foot lift Touch Switch is used to raise the foot for loading a mattress. The machine will not sew if the foot lift output is on. If the sew pedals are pressed while the foot is up, the conveyor will run at forward Aux speed or forward High speed.

There are four pedals that can be used: Aux Speed Sew, High Speed Sew, Head & Platform Down and Head & Platform Up.

- The Aux Speed Sew pedal runs the sew head at a preset speed set in the Efka motor and the conveyor will run at a preset speed set in the conveyor inverter. This pedal can be used to finish sewing off a mattress when the binding is overlapped or for sewing difficult mattresses at a slower speed.
- The High Speed Sew pedal runs the sewing head at high speed and the conveyor moves forward at medium (sew) speed.
- The Head & Platform Up and Down pedals are used to adjust the height of the sewing head and operator to the thickness of mattress being sewn.

There are two speed pots located on the side of the sewing head console: Side Speed and Corner Speed.

- The Side Speed pot is used to adjust only the speed of the sew head while sewing at high speed down the side of a mattress.
- The Corner Speed pot is used to adjust only the speed of the sewing head while sewing at low speed during the corner rotation.

The operator starts sewing in the middle of the Head end of the mattress. As the mattress approaches a corner, the Mattress Edge Detect Eye detects the edge of the mattress which starts the **Edge to Corner Stitch Count** setting. This setting decides how many stitches are sewn after the eye is uncovered before the mattress is rotated for corner sewing. The **Backstop Lock Stitch Count** setting is also used during this time to lock the Backstop in place a few stitches before the mattress is rotated for corner sewing. This setting ensures that the mattress is tight against the Backstop before the mattress is rotated.

After the **Edge To Corner Stitch Count** is reached, the head switches to a corner sew speed (low), the conveyor moves forward at low speed and the Rotate arm turns on in a forward medium speed. Everything stops if the operator releases the sew pedal.

Once the Rotate Arm Low Speed Sensor is reached, the Rotate Arm switches into a forward low speed until the Rotate Arm Out Sensor is reached which automatically sends the Rotate Arm home. The Rotate Arm then goes toward home in a reverse high speed for the length of the **Rotate Arm Reverse High On Time** setting. As the Rotate Arm starts home, the **Backstop Return Delay** is also turned on which delays the timing of when the Backstop transfer cylinder is sent home. This setting delays the Backstop from going home until it is clear of the mattress.

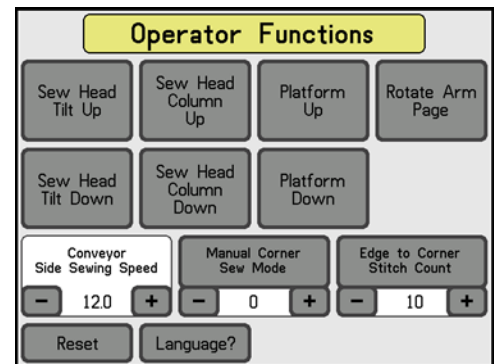
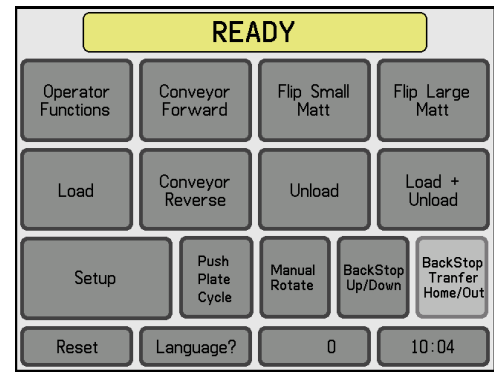

Once the **Rotate Arm Reverse High On Time** setting is reached. The arm is then switched into reverse low speed. The arm continues to move in reverse low speed until the Rotate Arm Home Sensor is reached. The **Rotate Arm Home Stop Delay** then starts which allows for adjusting the arm to stop parallel to the conveyor. Sewing resumes at high speed once the Rotate Arm Home Sensor is reached.

After all 4 corners are sewn and the binding is overlapped and finished off, the operator sews off the mattress and trims the thread with scissors.

The operator then pushes the Mattress Flip Cycle Button which corresponds to size (Small or Large) to start the flipping cycle. The first thing that happens during the flip cycle is the head push plate cylinder extends which pushes the mattress away from the head for flipping. Once the head push plate out sensor is reached, the conveyor turns on to move the mattress toward the mattress flipper.

If the **Mattress Flip Location** setting is set to "0" (infeed) the conveyor moves the mattress in the reverse direction toward the Mattress Flipper. If the Setting is set to "1" (outfeed) the conveyor waits until the Backstop is raised and then the conveyor moves the mattress in the forward direction toward the Mattress Flipper.

The Mattress Flip Eye detects the end of the mattress and turns on the **Edge to Mattress Flip delay**. If the Flip Eye does not see the mattress within 5 seconds, the conveyor turns off.

After the **Edge to Mattress Flip Delay** is reached the Mattress Flip Lift solenoid turns on which extends the mattress flip lift cylinders. The Mattress Flip Lift sensor is then reached approx. halfway up on the lift cylinders, which turns on the Mattress Flip Pivot solenoid and the **Mattress Flip Pivot On Time** setting. Once the **Mattress Flip Pivot On Time** setting times out, the Mattress flip pivot and lift cylinders retract and the conveyor turns off.

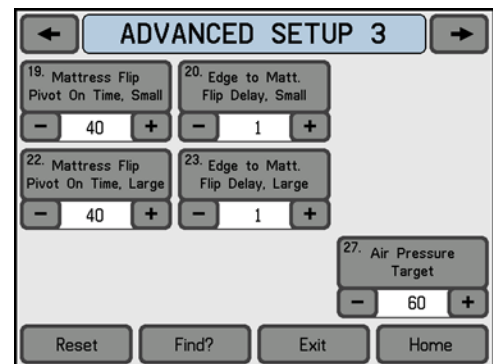
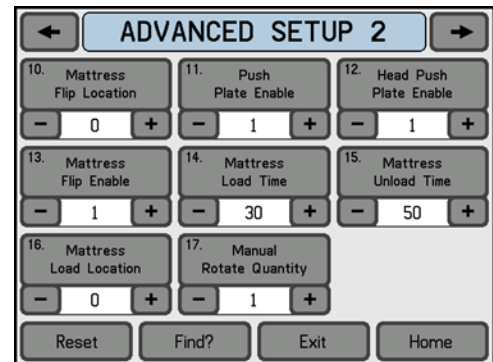
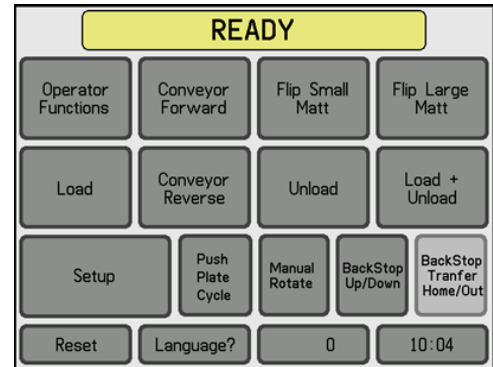
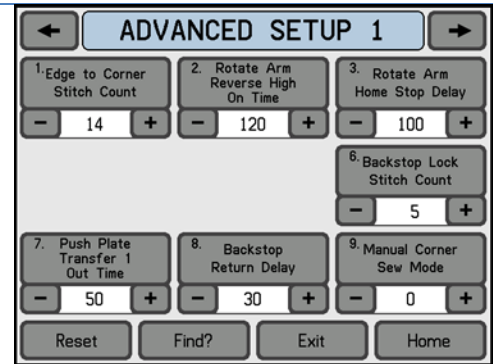

After the flip cycle has been completed the operator uses the High Speed Sew pedal to bring the mattress back to the middle of the conveyor. If the **Mattress Flip Location** setting is set to "0" the conveyor pedal will move the conveyor in the forward direction or if the setting is set to "1" the conveyor pedal will move the conveyor in the reverse direction. Once the operator releases the foot pedal, the push plate cycle is then initiated. During the flipping cycle, the Push Plate transfer 1 cylinder is extended. (if the **Push Plate Enable** setting is disabled, the transfer cylinder will not extend during the flipping cycle)

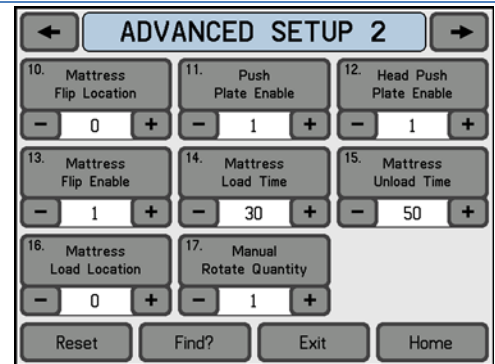

After the Push plate cycle is initiated, the Push plate lift cylinders extend until the lift sensor is true. Once the sensor is true, the Push plate transfer 1 cylinder retracts, and the Push plate transfer 2 cylinder extends. The software now looks at the Mattress edge detect eye to see that the mattress has been pushed all the way back to the sewing head.

Once the Mattress edge detect eye is covered for a short time, the Push plate transfer 2 cylinder retracts until the Push plate transfer 2 retract sensor is true. The Push plate lift cylinders are now retracted to lower the Push plate tray.

The operator is now ready to sew the other side of the mattress.

Notes:

1. There is also a **Manual Corner Sew Mode** setting that can be enabled. If this setting is enabled, it allows the operator to choose when to rotate for corner sewing instead of using the mattress edge detect eye. Once the eye uncovers, the sewing head and Conveyor stop.

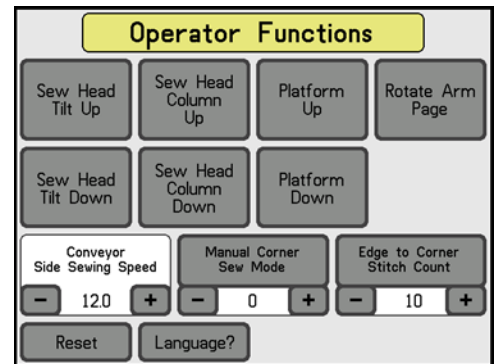

2. The operator can now use the Head & Platform Down pedal to sew in low speed to allow the operator to accurately stop where they want to rotate. Once the operator reaches the point where they want to rotate, they can now use the High-Speed Sewing pedal to start the rotate for corner sewing.

3. The operator can use the buttons on the Operator Functions page to adjust the Sew Head Column, Sew Head Tilt, and the Operator Platform individually for the correct ergonomic height relationship between the operator and the sewing head. After this is set, the operator can now use the Head & Platform Up and Down pedals to move the platform and the sew head up and down together for adjustment between different thickness mattresses.

Operational Path of Screens.

Ready

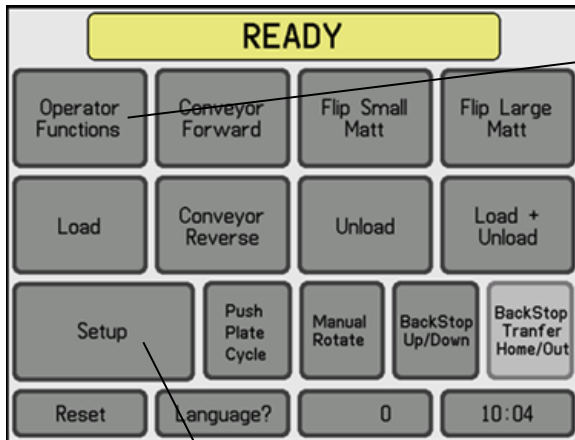

Operator Screen

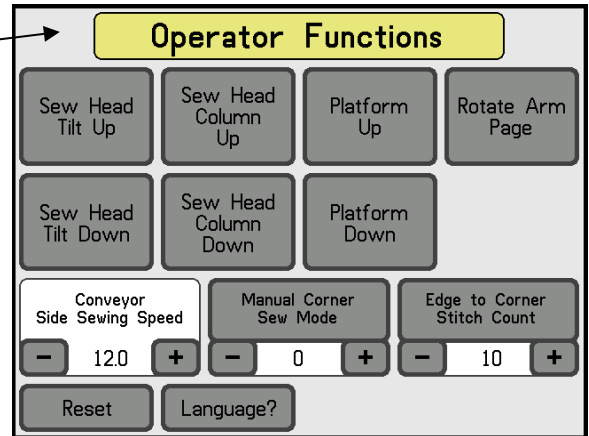

Setup

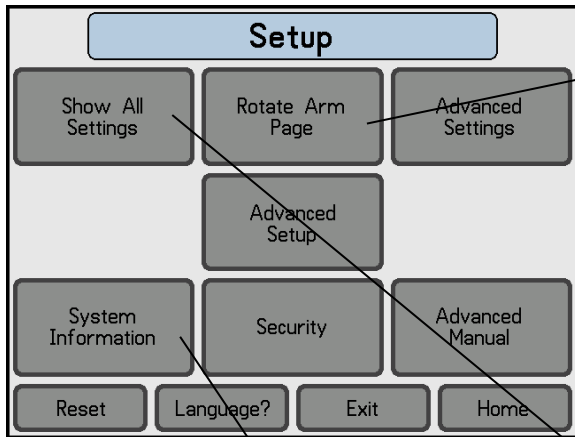

Rotate Arm Page

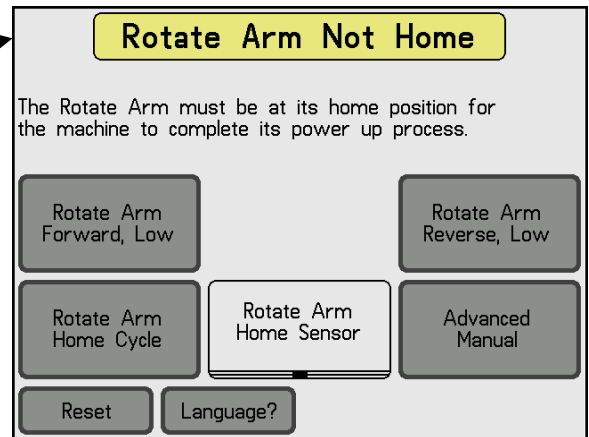

System Information



Show all Settings

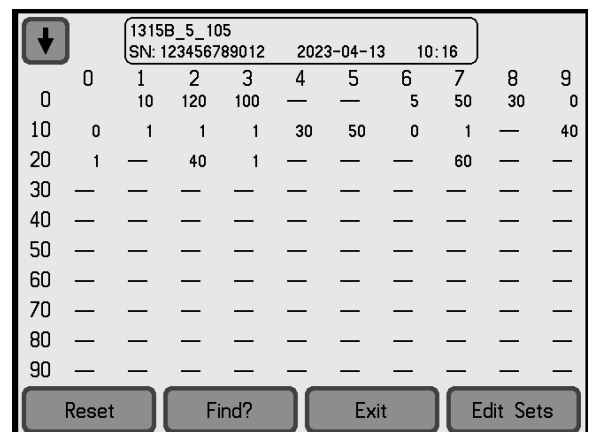

Advanced Settings

Setup

Show All Settings	Rotate Arm Page	Advanced Settings	
Advanced Setup			
System Information	Security	Advanced Manual	
Reset	Language?	Exit	Home

ADVANCED SETUP 1

1. Edge to Corner Stitch Count	2. Rotate Arm Reverse High On Time	3. Rotate Arm Home Stop Delay	
- 14 +	- 120 +	- 100 +	
		6. Backstop Lock Stitch Count	
		- 5 +	
7. Push Plate Transfer 1 Out Time	8. Backstop Return Delay	9. Manual Corner Sew Mode	
- 50 +	- 30 +	- 0 +	
Reset	Find?	Exit	Home

Security

Engineer

To lower your security clearance, enter the 5 digit security code and press ENTER.

1	2	3	Clear
4	5	6	
7	8	9	Enter
	0		

Lower Security Clearance

Security Code Bypassed

Reset Language? Exit Home

ADVANCED SETUP 2

10. Mattress Flip Location	11. Push Plate Enable	12. Head Push Plate Enable	
- 0 +	- 1 +	- 1 +	
13. Mattress Flip Enable	14. Mattress Load Time	15. Mattress Unload Time	
- 1 +	- 30 +	- 50 +	
16. Mattress Load Location	17. Manual Rotate Quantity		
- 0 +	- 1 +		
Reset	Find?	Exit	Home

ADVANCED SETUP 3

19. Mattress Flip Pivot On Time, Small	20. Edge to Matt. Flip Delay, Small		
- 40 +	- 1 +		
22. Mattress Flip Pivot On Time, Large	23. Edge to Matt. Flip Delay, Large		
- 40 +	- 1 +		
		27. Air Pressure Target	
		- 60 +	
Reset	Find?	Exit	Home

Advanced Setup

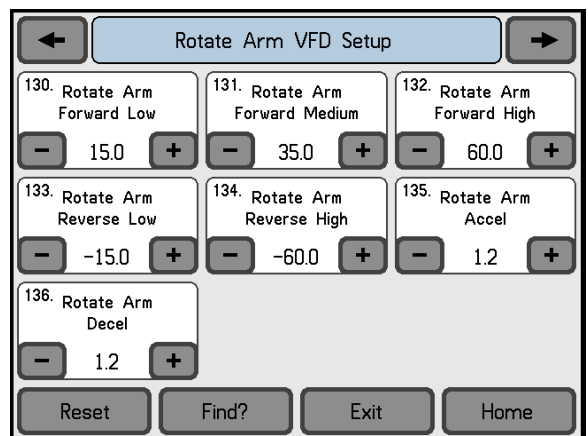
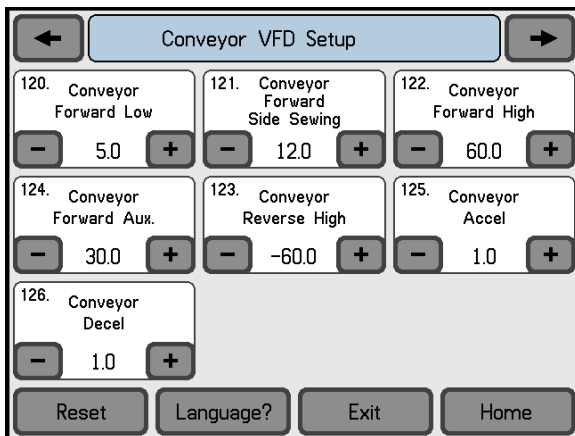
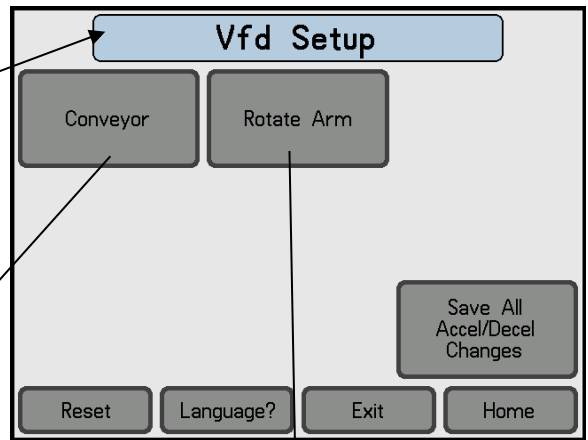
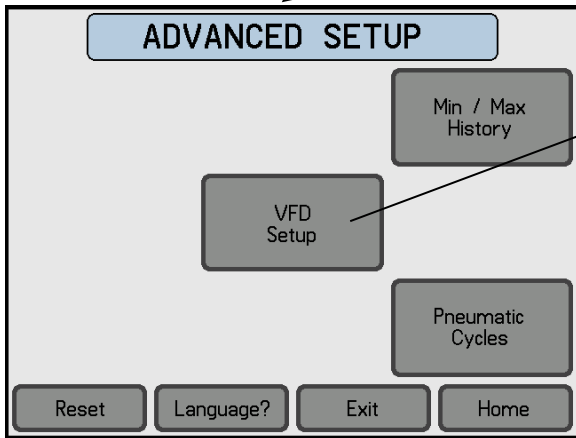
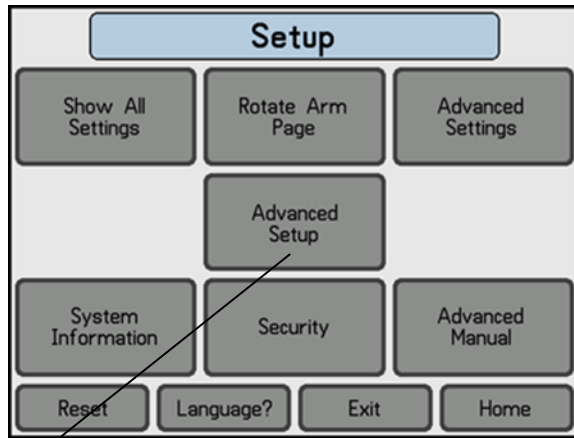

Advanced Manual

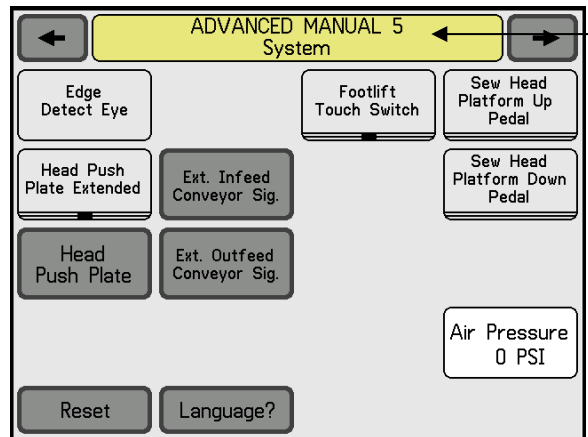
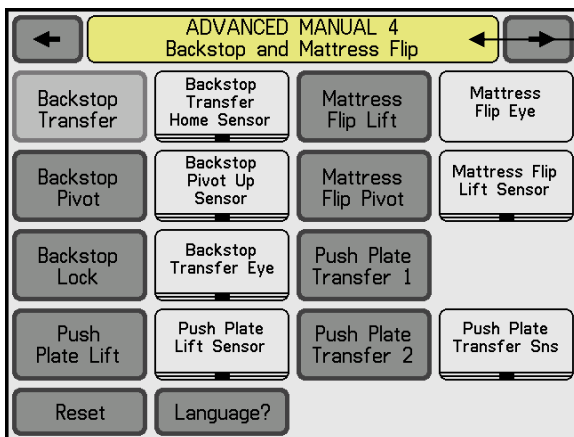
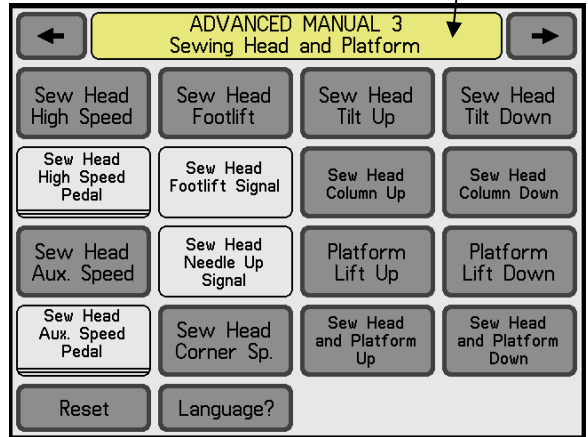
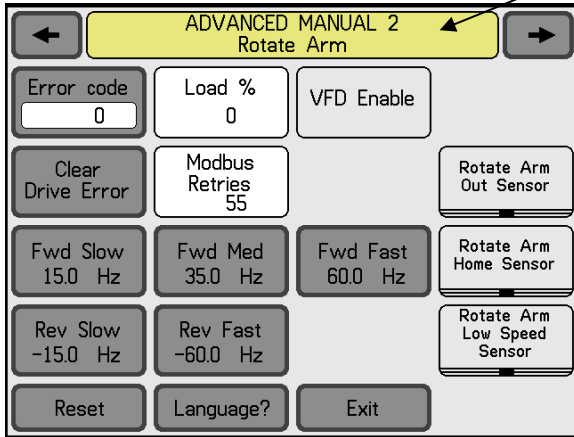
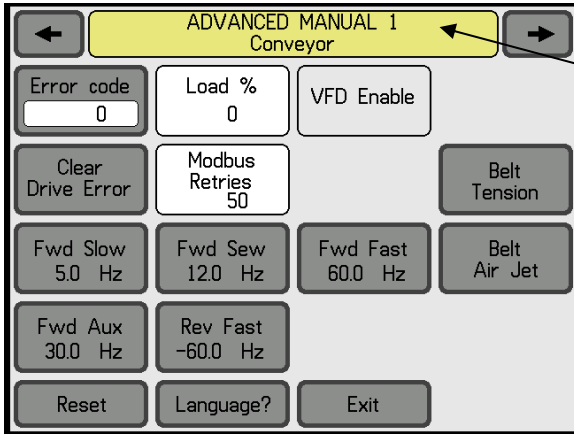
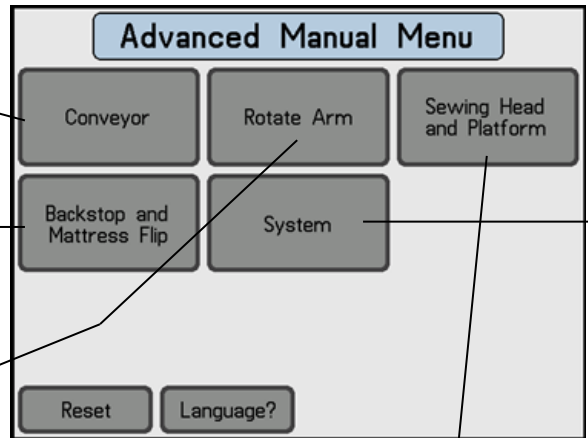
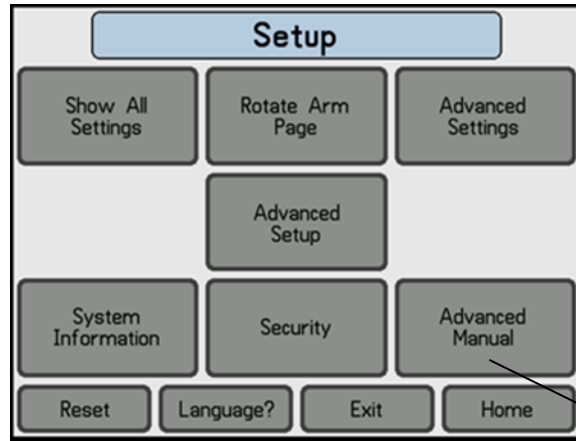

On-Board Diagnostics

Typical Warning Page example

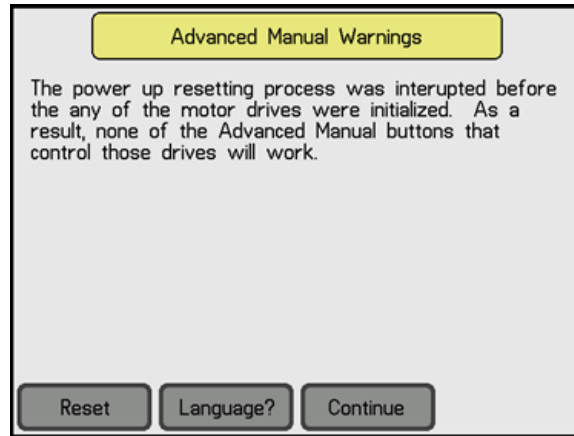

Help Screens.

Accessible by pushing at the top-middle section of a Button.

Typical Help Page example

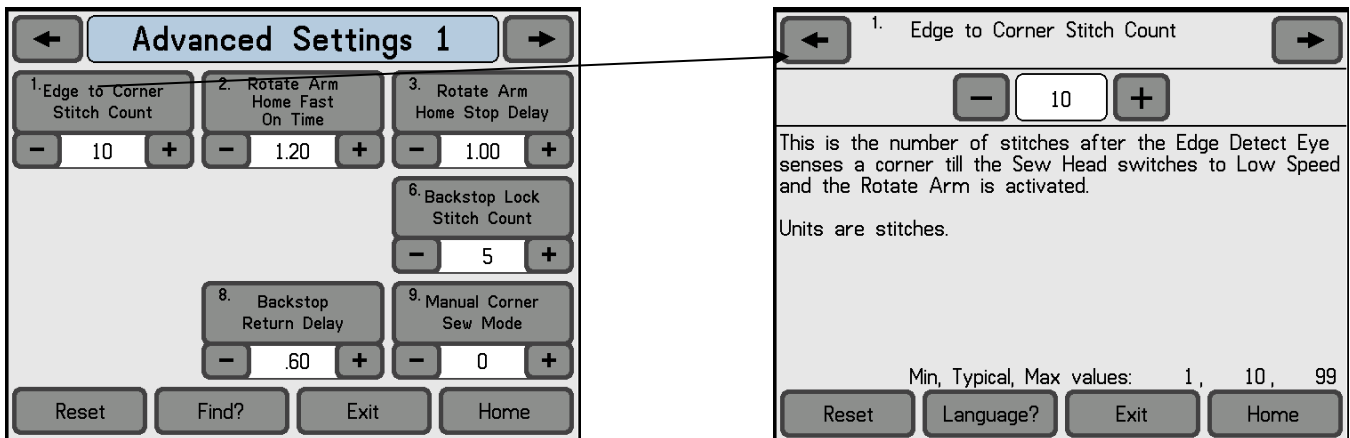

Efka Control Box

The sewing machine is powered by the Efka motor controller. It has its own on/off switch which should be always left on.

It also has some small buttons and LED's on the front to indicate the enabled functions. The only LED that should be on is the second to last from the bottom which sets the control to stop the machine needle down at neutral treadle and needle up after full heal back.

The functions can be changed upon power up or after a full heal back.

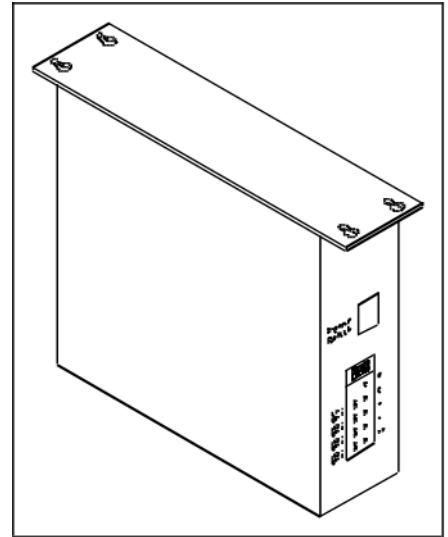

The control box has been programmed to operate specifically with the 1315B unit. If the box is later replaced, the new box will need to be programmed according to the included parameter list to function properly.

Notice that the sewing head does not stop at normal needle up (lockstitch heads) position after full heal back but stops at needle top dead center to allow more room for loading thicker material.

General Machine Maintenance

Daily

- Clean machine at the end of every shift.
- Clean lint etc. from the looper area on the sewing head.
- Remove any threads wrapped around moving parts.
- Wipe all photo eye lenses with a clean nonabrasive dry cloth.

- Use a blow-off hose to get rid of excess lint, thread, and other clippings.
- Open conveyor door and inspect belt for debris and remove with broom or air hose.
- Follow manufactures recommendations and guidelines for daily maintenance and lubricating of sewing head.

Weekly

- Check sewing head drive belt for tightness and condition.
- Inspect reflective tape on handwheel and replace if dirty or worn.
- Inspect conveyor bearings and remove thread and debris if needed.

Monthly

- Inspect conveyor bearings and apply one shot of bearing grease to each bearing as needed.

Electric Eye Sensor Adjustment

To adjust the sensor, first remove the clear plastic cover from the end of the sensor. There are two adjusting screws under the cover. One is labeled “GAIN” and is used to set the sensitivity of the sensor. The other screw is labeled “DO & LO” and should always be fully clockwise.

With the end of the sensor pointing at the center of the reflective tape, turn the “GAIN” screw counterclockwise until the red LED indicator is off. Then turn the “GAIN” screw clockwise until the LED indicator comes on. Then turn the “GAIN” screw one full turn clockwise. The LED indicator should be blinking slowly. Cover the eye so that the sensor cannot see the reflective tape and the LED should go off.

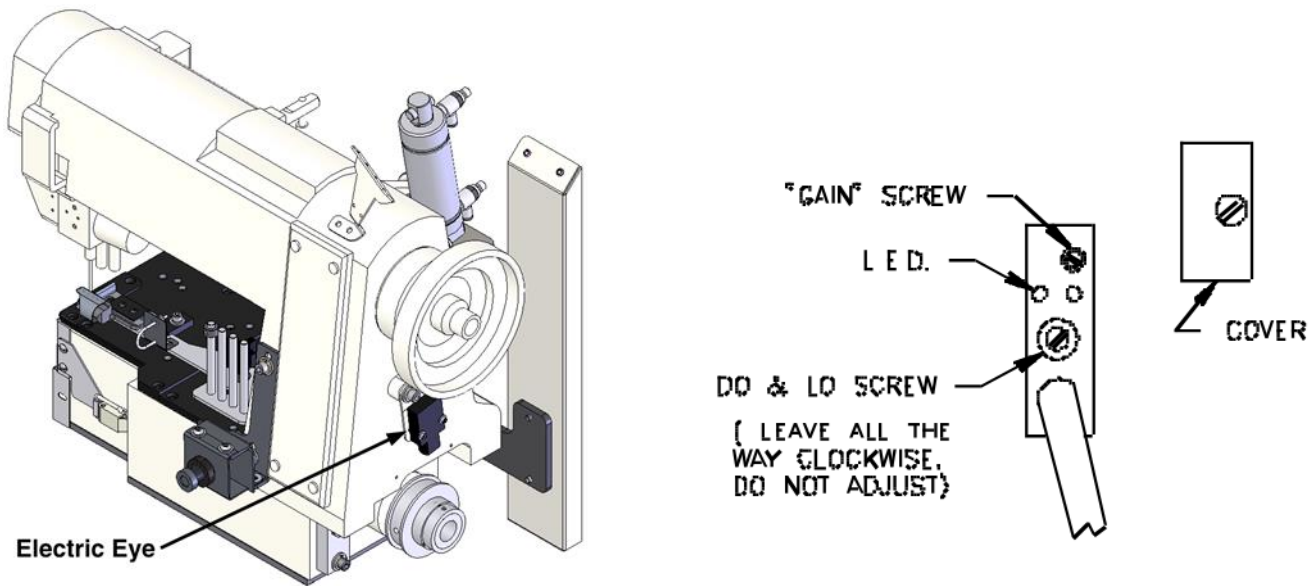

Reflective Tape Maintenance

- Use a soft cloth for cleaning.
- Do not use chemicals or abrasives to clean it.
- Avoid any contact with oils and liquids.
- Do not touch the tape with bare fingers.
- If tape is dirty or opaque, the eye may not function correctly.

Efka Parameter Settings (Sewing Head Motor)

Programming Instructions

Power on holding down the “P” button until “COD” is displayed.
Press “>>” once and enter the number “3112”
Press “E” once and “2.0.0” is displayed. This is a parameter.
Proceed to the parameter to be changed and press “E”.
The value now shows in the screen. Adjust to desired value.
Press “E” to enter value and continue with parameter setting.
Repeat for other parameters. Press “P” one time when complete.
Run sewing head to save parameters before powering down.

To Perform Master Reset of Parameters

Power on holding down the “P” button until “COD” is displayed.
Press “>>” one time and enter the number “5913”
Press “E” twice and “093” is displayed.
Press “+” once, “094” is displayed.
Press “P” to exit programming mode with all default values.

Before Programming, Perform a Master Reset of Parameters (See Below)			
PARAMETER	RANGE	VALUE	DESCRIPTION
290	0-26	05	Mode of operation. MUST SET THIS PARAMETER FIRST!
026	0-5	0	EB301 Treadle Mode (will not see if box has not been flashed)
111	400-9900 rpm	3200	Maximum side speed
112	200-9900 rpm	0200	Minimum corner speed
113	200-9900 rpm	1000	Maximum corner speed
114	200-9900 rpm	1500	Auxiliary sewing speed
124	200-9900 rpm	9900	Maximum possible for minimum side speed
125	200-9900 rpm	2000	Minimum side speed
153	0-50	35	Braking power at machine stand still
161	0-1	0=cw	Motor rotation
202	0-500	500	Sew start delay after footlift off
204	1-100	100	Holding power of footlift (disables footlift chopping)
219	1-55	35	Braking power at stop of the drive
220	1-55	05	Sew start acceleration of the drive
224	0-1	0	Speed gate 2 on/off
270	0-5	1	External handwheel sensor configuration.
271	0-255	165	Ref angle for Pos 1 (needle down) from Pos 2 (needle up tape)
272	020-255	0500	Drive ratio between motor pulley and handwheel pulley. If handwheel pulley is smaller than motor pulley, increase this value to slow down sewing head until measured speed matches speed set with parameter 111. (For Yamato and Pegasus, setting should be 100; for Rimoldi, setting should be 124)
362	0-1	1	Position sensor voltage: 0 = 5V, 1 = 15V
436	0-1	0	This disables an input that was causing box to reset itself.
401	0-1	1	Save all settings
Front panel LED's:			Programming Instructions:
LED 1:	Off		1. Power on holding down the "P" button till "CODE" is displayed.
LED 2:	Off		2. Press ">>" once and enter the number "5913"
LED 3:	Off		3. Press "E" once and "4.0.0." is displayed this is a parameter
LED 4:	Off		4. Proceed to the parameter to be changed and press "E"
LED 5:	On, Stop at needle down		5. The value now shows in the screen, adjust to desired value.
LED 6:	Off		6. Press "E" to enter value and continue with parameter setting.
LED 7:	Off		7. Repeat for other parameters, press "P" once when complete.
LED 8:	Off		8. Run sewing head to save parameters before powering down
			To Perform Master Reset of Parameters:
			1. Power on holding down the "P" button till "CODE" is displayed.
			2. Press ">>" once and enter the number "5913"
			3. Press "E" twice and "093" is displayed.
			4. Press "+" once, "094" is displayed.
			5. Press "P" to exit programming mode with all default values.

Front Panel LED's:

LED 1-6: Off, LED 7: On, Stop at needle down, LED 8: Off

Speed Setting Controls

Use the information below to help select which electrical component to adjust in order to synchronize the following sewing speeds.

Side Sewing Speed Controls

Sewing head - Side speed pot located on the sewing head console.
Conveyor - Serial Bus Parameter 121

Corner Sewing Speed Controls

Sewing head - Corner speed pot located on the sewing head console.
Conveyor - Serial Bus Parameter 120
Rotate arm - Serial Bus Parameter 131

Auxiliary Sewing Speed Controls

Sewing head - Efka control box - Parameter 114 (default = 150)
Conveyor - Serial Bus Parameter 124

The Auxiliary sewing speed can be adjusted and used for any additional speed the operator may require. It can be used for slow speed stitching to finish off a bed or it can be set as an additional sewing speed to be used to sew around difficult to sew beds.

Conveyor Belt Tracking Instructions

Turn off the air pressure before making any adjustments.

1. Make sure the upper conveyor drive roller is perpendicular to the frame. The motor mounted end of the roller (**a**) is fixed so this is your starting point. The other end of the roller (**b**) should be adjusted after losing the screws (**c**) in or out until it is in the same relationship to the frame as the motor mounted end.

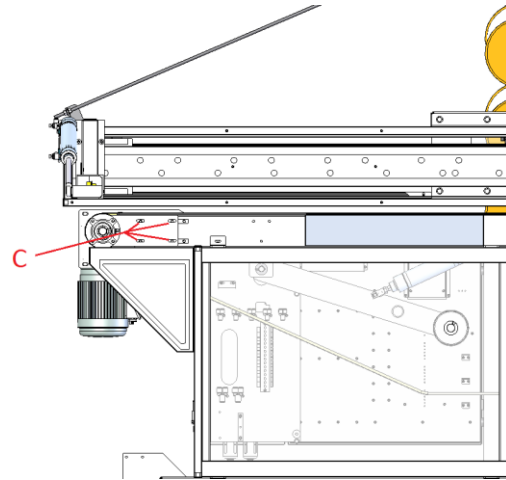
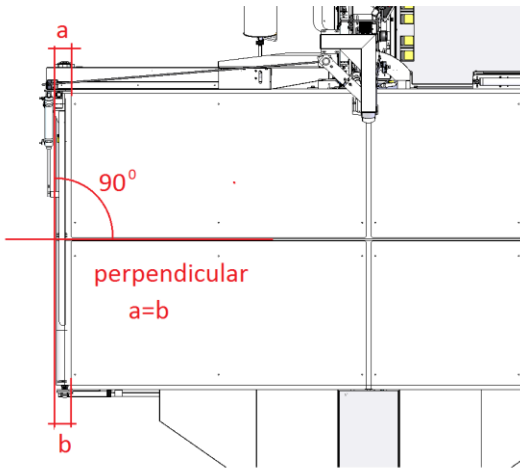

2. Make sure the upper conveyor driven roller is parallel to the upper conveyor drive roller. This can be determined by measuring diagonally across the conveyor from opposite ends of each roller (**d**) (**e**). Adjust the mounting brackets for each end of the driven roller releasing the 4 screws (**f**) and readjusting the screw (**g**) until both diagonal measurements are the same.

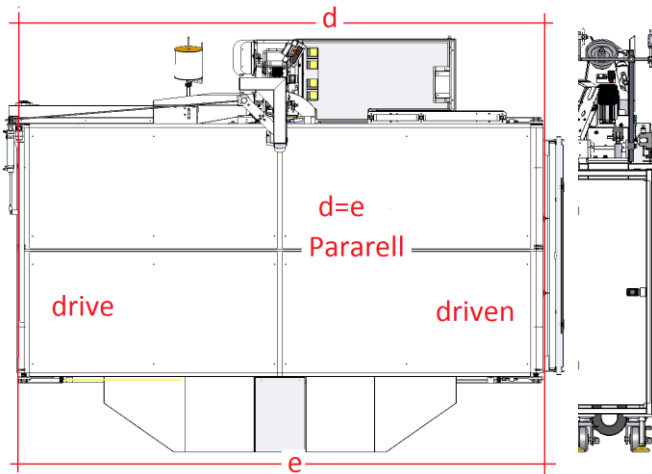

3. Locate the lower idler roller assembly mount brackets that are attached to the upper frame. **(h)** These mount brackets each have two adjustment screws **(i)** **(j)** that allow you to tilt the mount bracket forward or backward in relation to the conveyor belt travel.

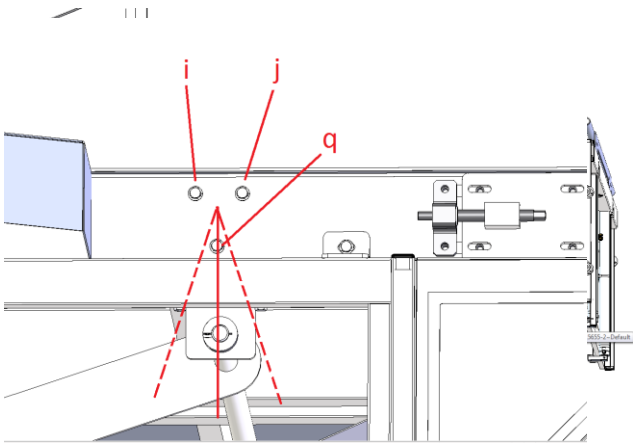

4. Start the adjustment process with all four mount brackets adjusted perpendicular to the conveyor frame. **(k)** **(l)** **(m)** **(n)**.

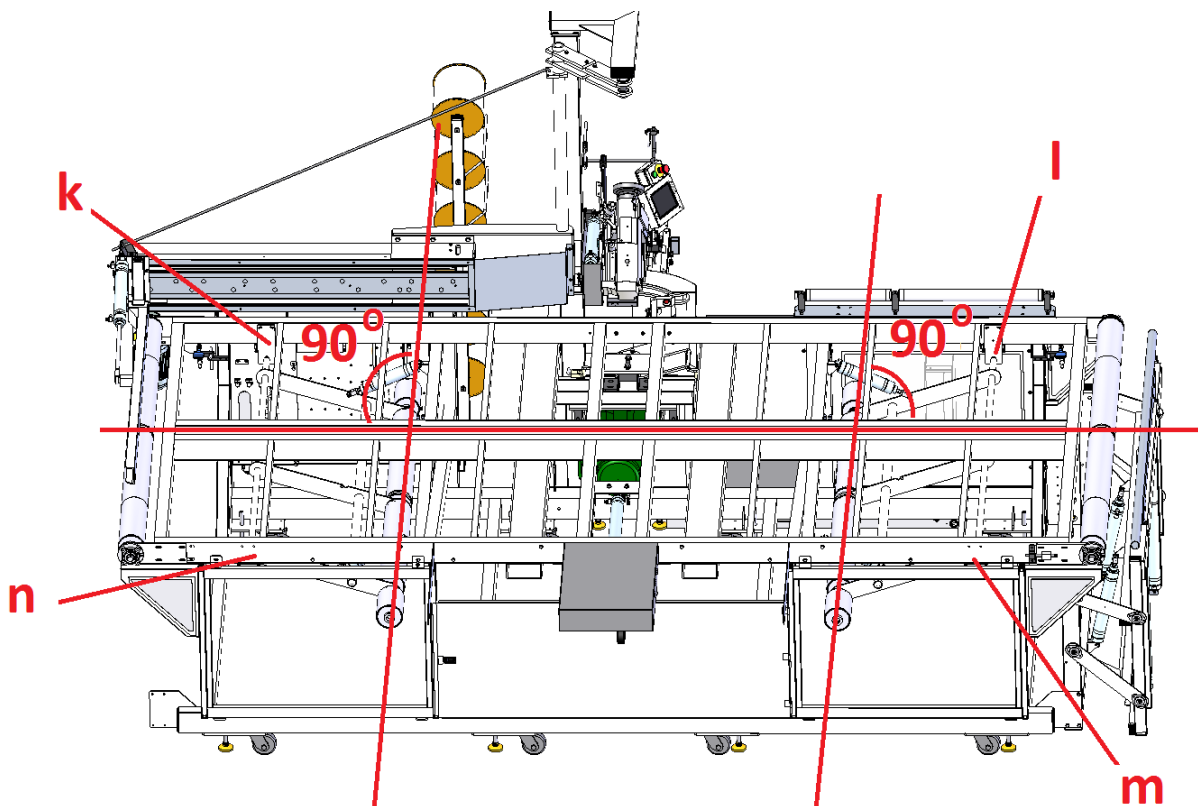

- A. If the belt is tracking toward the operator (o) , adjust the driven roller mount brackets as follows:**

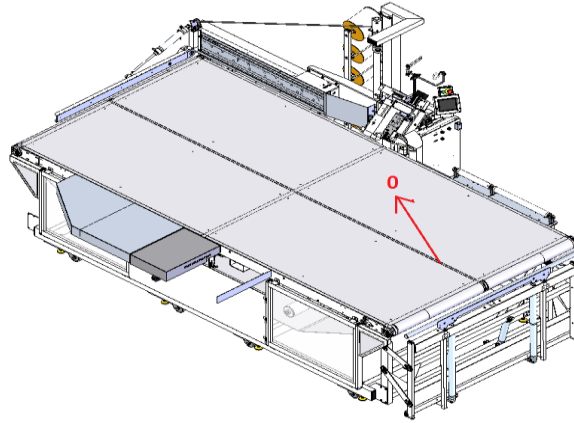

The mount bracket that is on the same side as the operator **(l)** should be tilted to the right **(p)** toward the drive roller end of the conveyor. The three mounting bolts for each bracket **(i) (j) (q)** must be loosened before the bracket can be adjusted.

Adjust the mount bracket on the opposite side of the same roller **(m)** the same angle as the first bracket, **but in the opposite direction** (toward the driven roller **(r)**). Both brackets need to be adjusted the same amount to ensure that the lower idler roller remains parallel to the upper conveyor surface.

- B. If the belt is tracking away from the operator, adjust the driven roller mount brackets in the opposite direction as mentioned in step 5.**
5. Make sure all adjustment screws are touching the lower surface of the frame member and that the bracket mounting bolts are tightened properly.
 6. Turn on the air pressure and test the belt tracking with the manual conveyor buttons on the touch screen.

Servicing the Sew Head

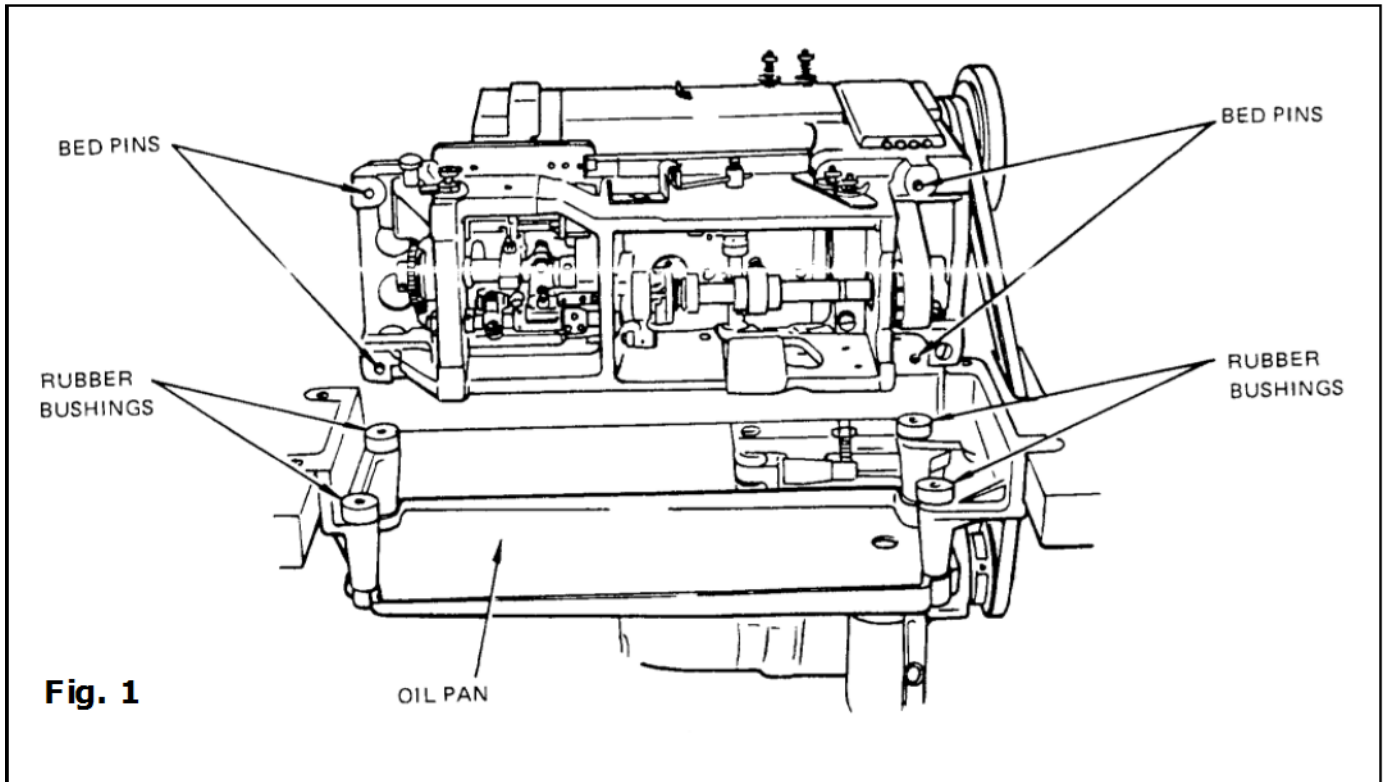

Installation

Assemble the oil pan to the hangers. Insert the assembled oil pan into the machine cut-out table placing four rubber bushings in the hanger holes as shown in Fig. 1. Attach the oil drain jar to the oil pan as shown in Fig. 2.

Place the machine on the oil pan assembly with the four bed pins passing through the four rubber bushings shown in Fig. 1.

Connect the foot lifter treadle to the foot lifter lever, Fig. 3, at the back of the machine by chain furnished for this purpose.

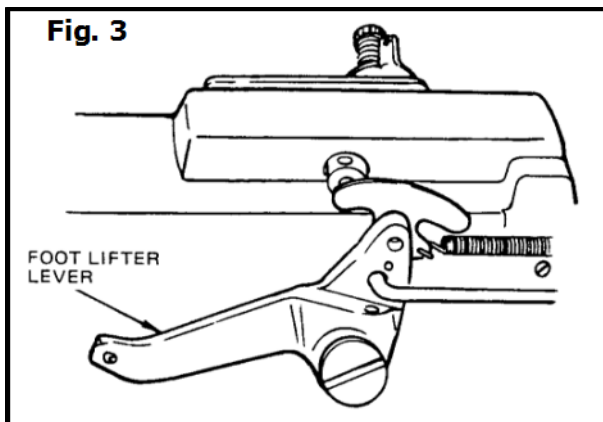
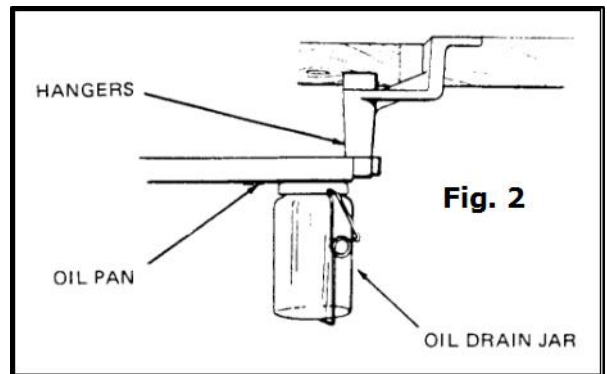

Lubrication

Machines of Class 300U have a semi-automatic lubricating system comprising of a hollow arm shaft and a hollow bed shaft which act as oil reservoirs. The oil is distributed to all the principal bearings by centrifugal force through small jets in the shafts when the machine is in operation.

Provision is also made for hand lubricating other movable parts which are not

lubricated from the reservoirs.

Caution:

User machine oil, “Type B” or “Type D”. Use “Type D” oil when an oil is desired which will produce minimum stain on fabrics even after long period of storage.

Do not use additives in sewing machine oil as they may cause a reduction in the normal flow of oil that can result in damage to the machine.

Before starting the machine, the machine must be oiled as instructed. Failure to do this will result in damage to the machine.

The Pressure Oil Can, furnished with the machine is to be used to oil all points requiring lubrication.

To Oil the Arm Shaft

To fill the arm shaft reservoir, insert spout of the pressure oil can in hole, Fig. 4, and inject 1 shot of oil into shaft twice daily.

To Oil the Bed Shaft

To fill the bed shaft reservoir, push the spring cover, Fig. 5, to the left and insert spout of pressure oil can into the hole and inject 1 shot of oil into shaft twice daily. Close oil hole spring cover.

Other Oiling Points

Applying oil to all work plate and arm oil holes, needle bar bearings and connections, needle bar rock frame bearings, looper rocker sleeve and presser lifting mechanism.

Caution:

For machines in continuous use, all oiling points must be oiled daily. Occasionally oil tension release mechanism and looper pull-out rack.

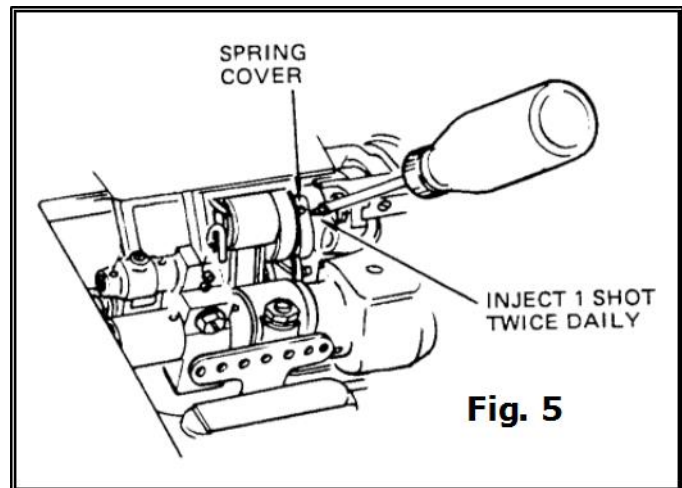
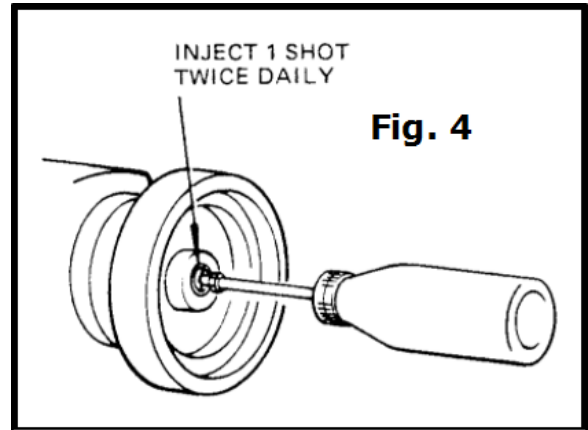

Setting the Needle

Refer to Fig. 6.

Turn the machine pulley over toward the operator until the needle bar is at its highest point.

Loosen the needle set screw.

Insert the needle into the needle bar and clamp as far as it will go making certain that the scarf of the needle faces toward the left.

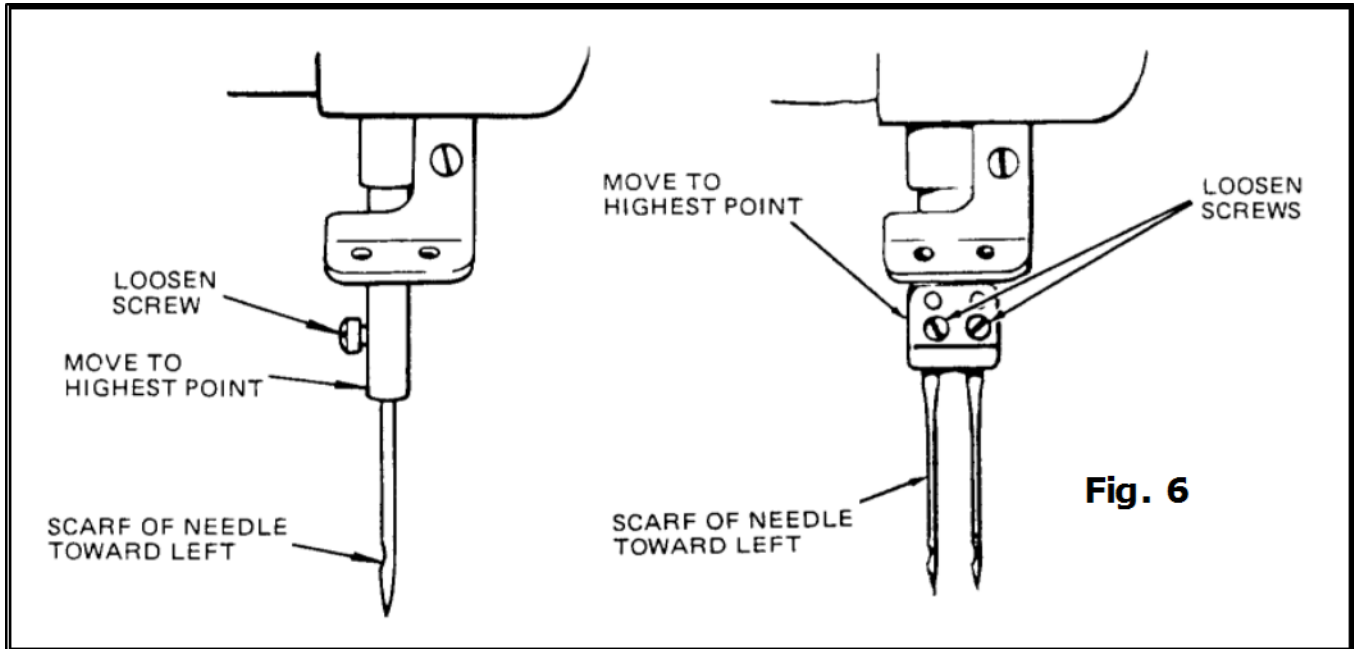

Threading the Machine

Either left twist or right twist thread may be used in the needles and loopers. Rough or uneven thread, or thread which passes through the needle eye with difficulty will interfere with successful operation of the machine.

Upper Threading

Turn the machine pulley over toward the operator until the needle bar is at its highest point. Pass the thread from the unwinder through the threading points indicated in Fig. 7. Draw approximately two inches of thread through the needle eye with which to start sewing. Make certain that each thread passes through the thread tension device.

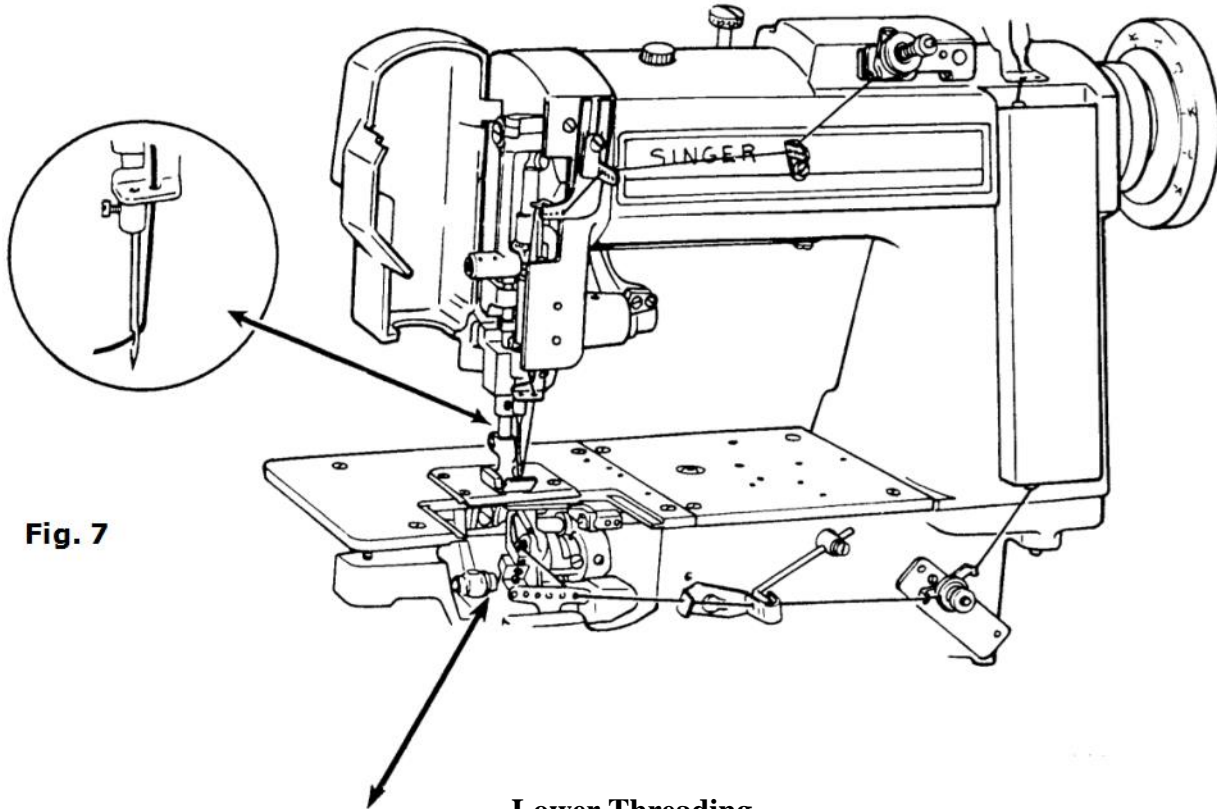
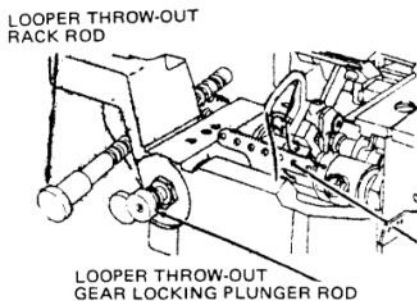

Fig. 7

Lower Threading

Open the front table section, remove the bed slide and turn the machine pulley over toward the operator until the needle bar is at its highest point. Move the looper throw-out gear locking plunger rod and looper throw-out rack rod, Fig. 7, out as far as possible. This will place loopers in position for easier threading and prevent accidental operation of machine until loopers are returned to sewing position.



Threading The Loopers

Pass the thread from the unwinder through the threading points as indicated. Draw approximately two inches of thread through the looper eye with which to start sewing.

Tension

Tension on the thread should be as light as possible while still sufficient to set the stitch correctly in material.

Needle Thread Tension

To regulate the needle thread tension, turn the thumb screw indicated in Fig. 8 as may be required.

Important: Regulate the needle thread tension only when the presser foot is down.

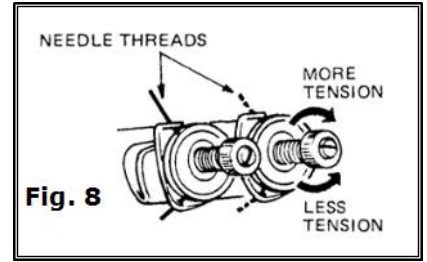

Fig. 8

Looper Thread Tension

To regulate the looper thread tension, turn the thumb screws as indicated in Fig. 9 as may be required.

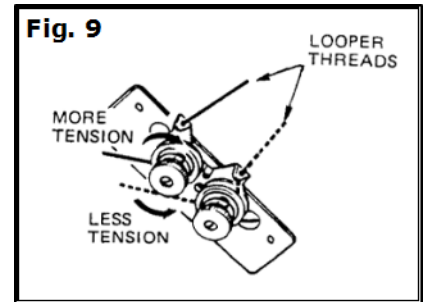

Fig. 9

Pressure

Pressure on material should be as light as possible while still sufficient to insure correct feeding.

Presser Foot Pressure

To regulate the presser foot pressure, loosen the lock screw, Fig. 10, at the rear of the machine. tighten the thumb screw to increase pressure; loosen to decrease pressure. When the correct feeding pressure is attained, tighten the lock screw.

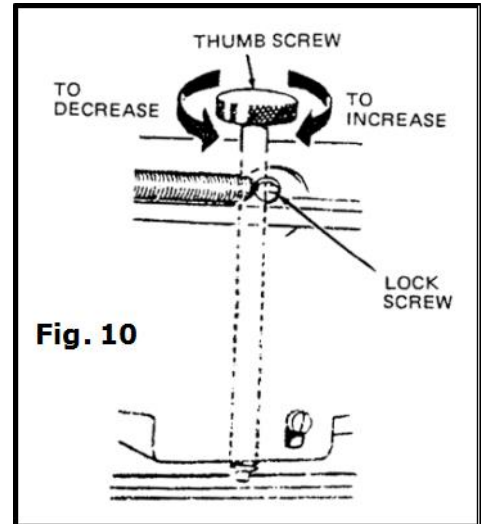

Fig. 10

Alternating Pressers

To increase pressure, loosen the lower lock nut and loosen the lock screw, then tighten the upper lock nut, see Fig. 11. When the correct pressure is attained, tighten the lock screw. Then tighten the lower lock nut. To decrease pressure, loosen the upper lock nut and loosen the lock screw, then tighten the lower lock nut. When correct pressure is attained, tighten the lock screw. Then tighten the upper lock nut.

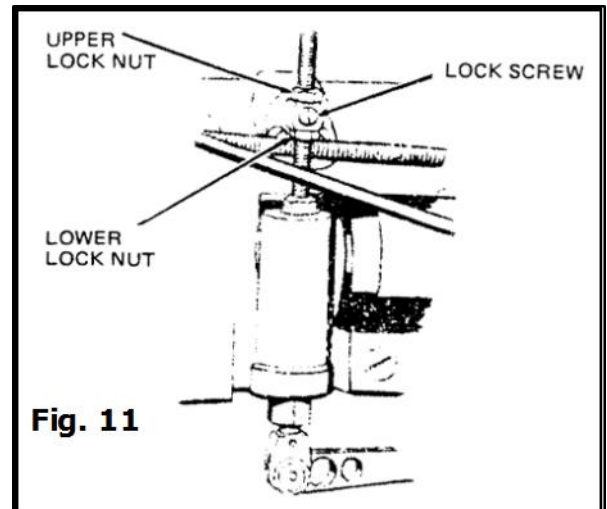
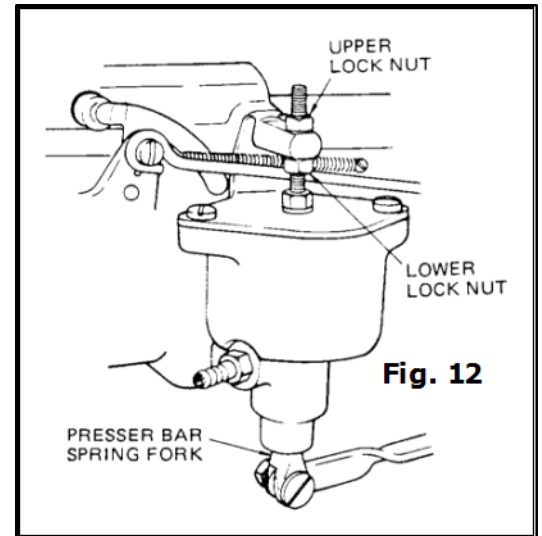

Fig. 11

Alternating Presser with Pneumatic Pressure Control

Adjust the height of the Pressure Cylinder with the presser feet resting on the throat plate. There should be a clearance of 1/4" between the Presser Bar Spring Fork and bottom of the cylinder. To raise the cylinder, loosen the lower lock nut and tighten upper lock nut, see Fig. 12. To lower the cylinder, loosen the upper lock nut and tighten the lower lock nut. When correct adjustment is attained, tighten both lock nuts.

Regulate air pressure: The correct air pressure is set for average feeding when the Presser Bar Spring Fork rises to approximately 1/16" from the bottom of the cylinder.



Upper Feed Roll Pressure

To regulate the pressure of the upper feed roll, turn the thumb screw as shown in Fig. 13.

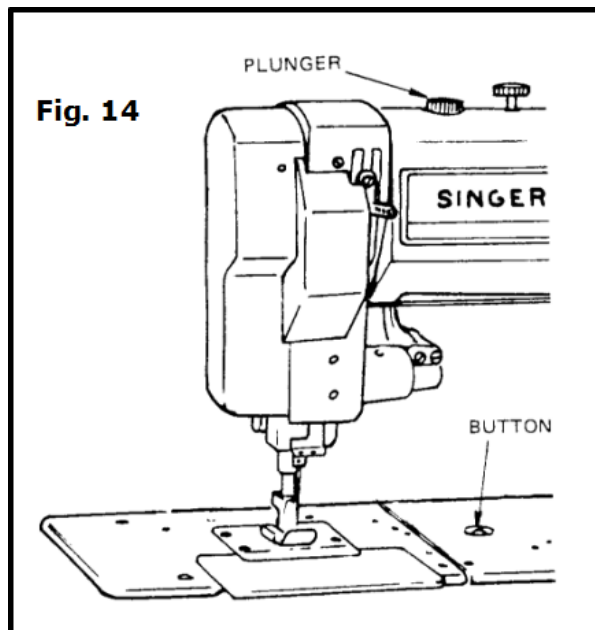
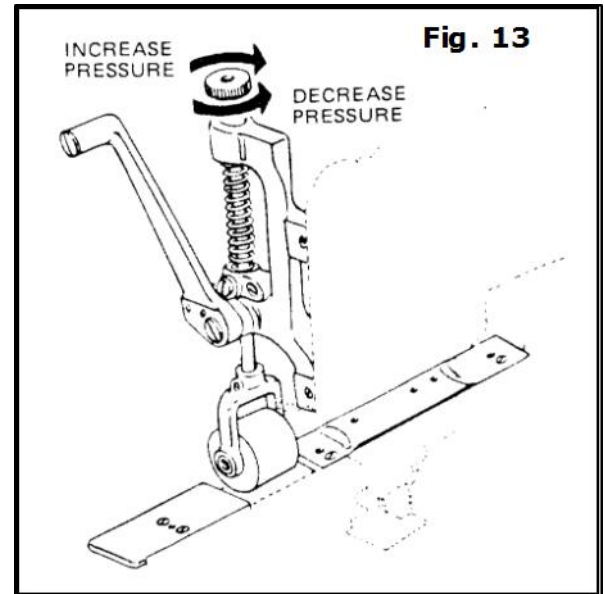

Stitch Length

To adjust the stitch length, depress the plunger, Fig. 15, located on top of the arm. Continue to hold the plunger down and turn the machine pulley toward the operator until the plunger enters the notch in the arm shaft eccentric. Then turn the plunger to lock in position. Depress the button located on the machine bed. Hold down and turn the machine pulley toward the operator to increase length of the stitch, or away from the operator to decrease the length of the

stitch. Letter "A" on the machine pulley indicates the lowest stitch. When desired length is indicated by a letter and is opposite of the arrow on the front of the machine, release button and turn the plunger to the right or left until it springs outward.

Caution: Never turn the machine pulley with the plunger in the locked position until the button on the machine bed is depressed.

Machine with Puller Feed

The length of the stitch is determined by the stitch gears in the puller feed mechanism. The compound feed stitch length should be set slightly shorter than the stitch length of the puller feed.

To change the Puller Feed gears for adjusting stitch length, remove the two cover plate screws and remove the cover plate, Fig. 15. Loosen the set screws. Slide the puller feed shaft to the right far enough to allow removal of the worm and worm gear. Place the new worm on the cross shaft. Turn the worm in the operating direction and tighten the first set screw into the flat of the shaft. Then securely tighten both set screws, checking for excessive end play. Engage the new worm gear with the worm and slide the puller feed shaft through the worm gear until the end of the shaft is flush with the needle bearing. Remove the end play in the shaft.

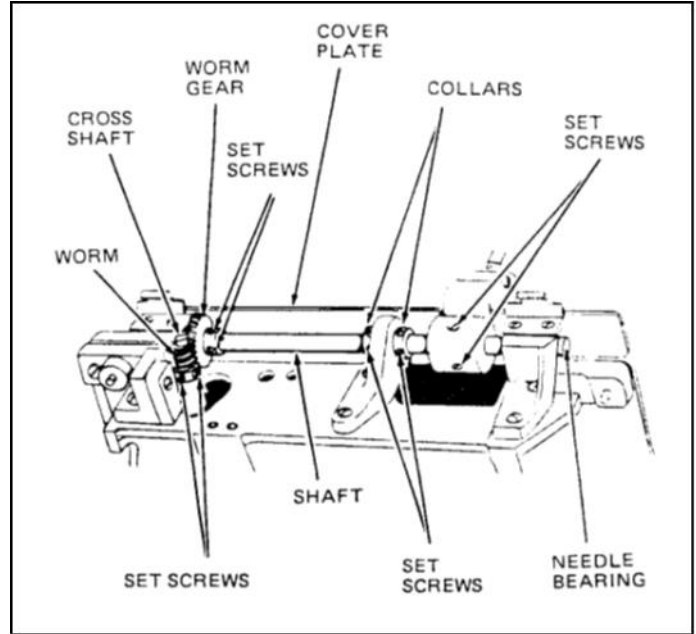

by setting the two collars against the bracket and tightening the four set screws. Align the lower feed roll with the upper feed roll and tighten the two set screws. Center the worm gear on the center of the worm. Tighten the two set screws with the first screw in the spline of the shaft. Replace the cover plate and adjust the compound feed.

Presser Bar Lift

When the presser foot is raised by the presser bar lifter and the needle is at its highest position, the point of the needle should not protrude below the presser foot.

To adjust, turn the machine pulley over toward the operator until the needle is at its highest position. Loosen the set screw, Fig. 16. Raise the presser foot to the correct height, place the stop collar against the upper bracket, and tighten the set screw.

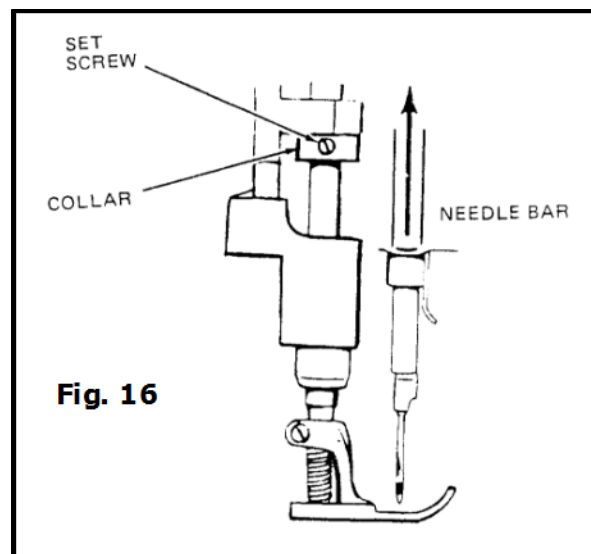

Machines with Alternating Pressers

The lift of the vibrating and lifting pressers is controlled by an adjustable eccentric. To adjust, remove the arm cover at the rear of the machine. Turn the machine pulley over toward the operator until the feeding presser is down. Loosen the two-lock screw, Fig. 17, and the two clamp screws. Insert a screwdriver into the notch of the adjusting disc, and turn the machine pulley as indicated in Fig. 17. Then tighten the two clamp screws and the two lock screws.

When it is desirable to have either one of the pressers lift higher than the other, turn the machine pulley over toward the operator until the lifting presser is at its highest position. Loosen the tow clamp screws, Fig. 18, and turn the lifting rock shaft crank up or down until the desired lift of each presser is attained. Then tighten the tow clamp screws.

Caution: Limit lift of pressers to a minimum required for the work, as this permits higher speeds.

The vibrating presser should be timed so that under normal sewing conditions, the presser foot will seat on the material at approximately the same time the needle enters the material. This timing can be advanced or retarded slightly depending on the type of operation being performed, such as sewing over seams. To adjust, loosen the tow holding screws, Fig. 18, not more than one half turn. Then turn the adjustable eccentric, Fig. 17, until the vibrating presser seats at the correct time. Securely tighten the tow holding screws after the adjustment is made.

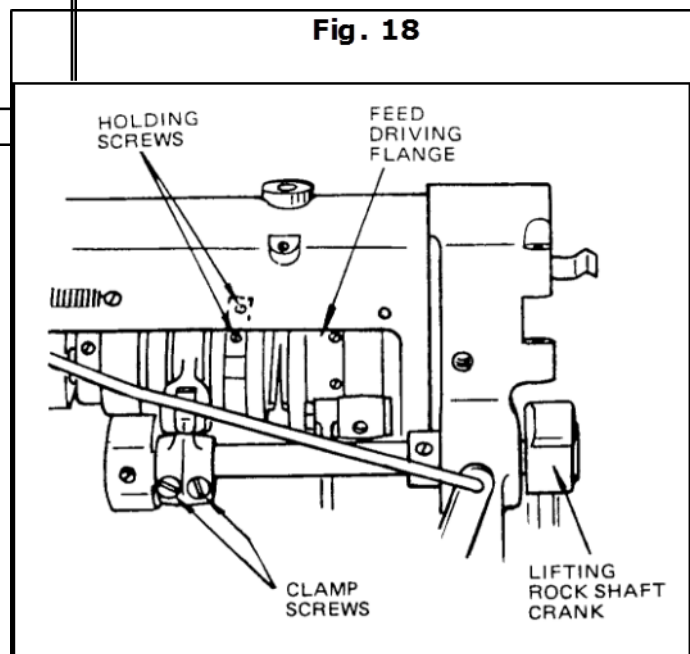
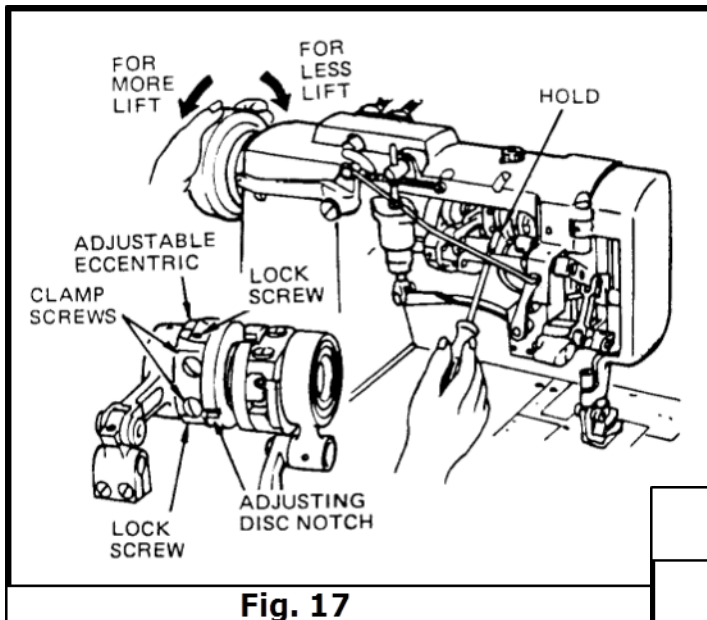

Setting the Height of Feed Bar

When the feed bar is set at the correct height, the feed lift link clamp will be aligned with the rock shaft timing flat. To adjust, make certain that the feed lifting crank timing screw, Fig. 19, engages the shaft spot correctly. Loosen the clamp screw and move the feed lift clamp link to the correct position. Then tighten the clamp screw.

Centralizing the Feed Dog

Sidewise Setting

The needle should enter the needle hole of the feed dog with the same clearance between the needle and the left or right side of the hole. To adjust, loosen

the feed dog screws, Fig. 20. Move the feed dog until the correct clearance is attained. Hold in position and tighten the feed dog screws.

Additional adjustment, if necessary, may be attained by loosening the four-shaft collar set screws, the two rock shaft crank clamp screws, Fig. 20, and the feed lifting clamp screw, Fig. 19. Move the complete assembly to required position and tighten screws.

Lengthwise Setting

The feed dog should clear the ends of the feed slots in the throat plate equally at both ends of the feed travel. To adjust, set the feed for the desired stitch length. Loosen the two-rock shaft crank clamp screws, Fig. 20. Move the feed rocker forward or backward until the correct positioning is attained. Then tighten the two clamp screws.

Setting the Height of the Feed Dog

When the feed dog height is set correctly, approximately the full depth of the teeth will show above the throat plate. To adjust, loosen the lock nuts, Fig. 21, and slightly loosen the feed dog clamping screw. To raise the feed dog turn the jack screw clockwise; to lower, turn the jack screw counterclockwise and tap the feed dog down. When the correct setting is attained, tighten the clamping screws and lock the nuts.

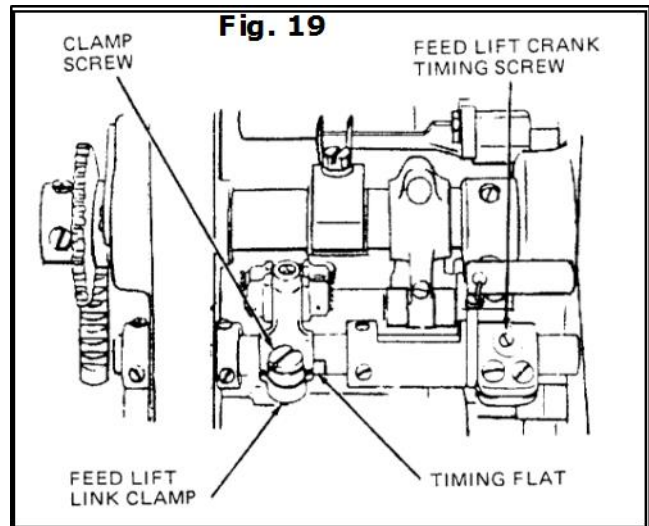

Fig. 20

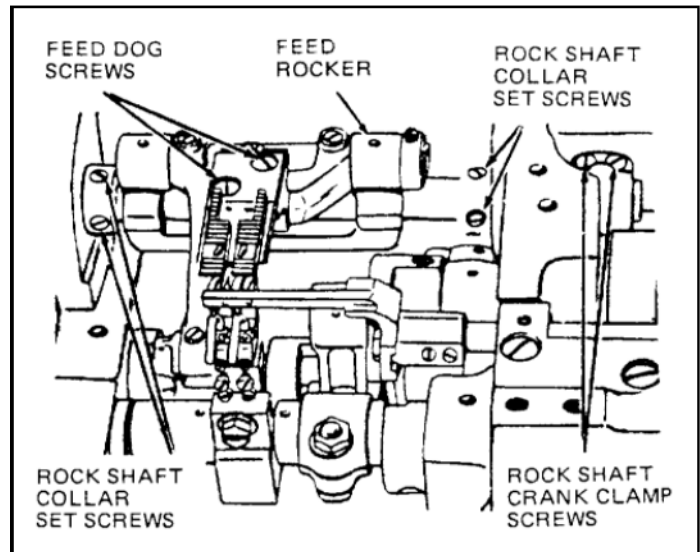
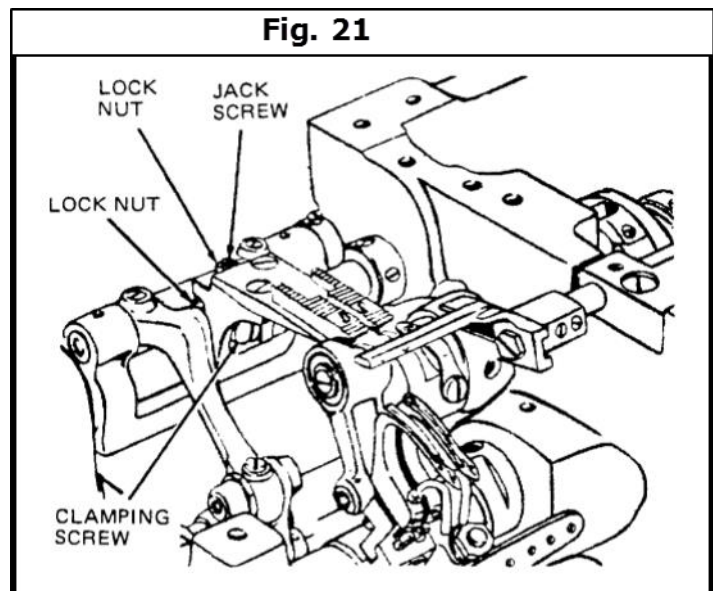
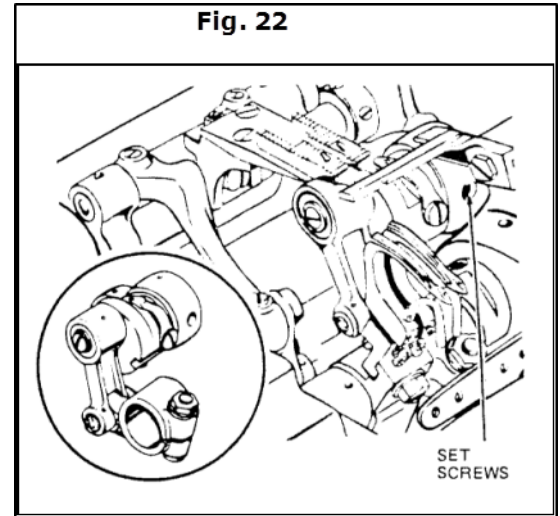

Fig. 21



Timing the Feed Lift Eccentric

When the feed dog is at its highest position, the top of the teeth should be parallel with, and project full depth of the teeth above the upper surface of the throat plate. To adjust, insert screwdriver in the hole in the feed strap and loosen the two set screws, Fig. 22. Move the feed lift eccentric forward for earlier rise of the feed dog, or backwards for later rise. Then tighten the two set screws.



Needle Bar Positioning

The needles should enter the needle holes of the feed dog toward the front with approximately the same clearance between the front of the needles and the needle holes as at the side. To adjust, press the needle bar rock frame, Fig. 23, against the drive arm clamp screws. Continue holding the rock frame against the drive arm, move the needle bar to correct the position and tighten the two clamp screws.

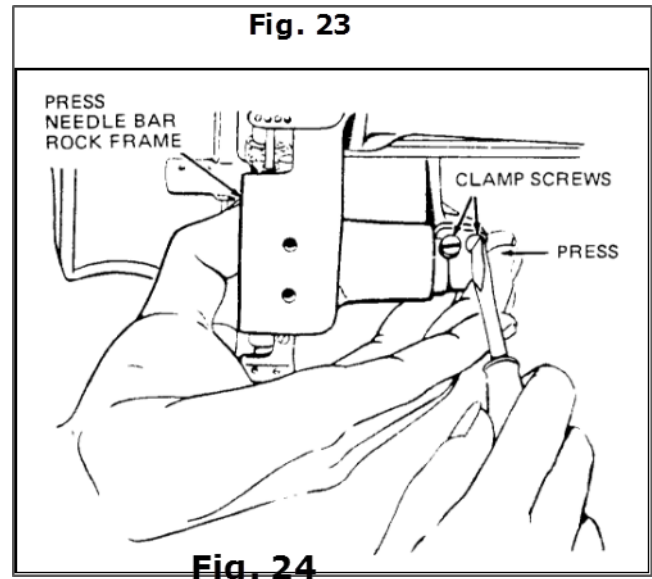

Positioning the Loop Deflectors

When the loop deflector, located on the underside of the feed dog, is positioned correctly, there should be a clearance of approximately 1/32" between the right side of the needle and loop deflector. To adjust, move the looper out of sewing position and tilt the machine back on its hinges. Loosen the loop deflector screws, Fig. 24. Move the deflectors toward the rear of the feed dog as far as the screw slots allow. Tighten slightly to allow for further adjustment. Return the looper to the sewing position and turn the machine pulley until the needle bar has descended to the bottom of the needle bar stroke. Tap the deflector to the left or right until the correct clearance is attained. Move the looper out of the sewing position and tighten the loop deflector screws.

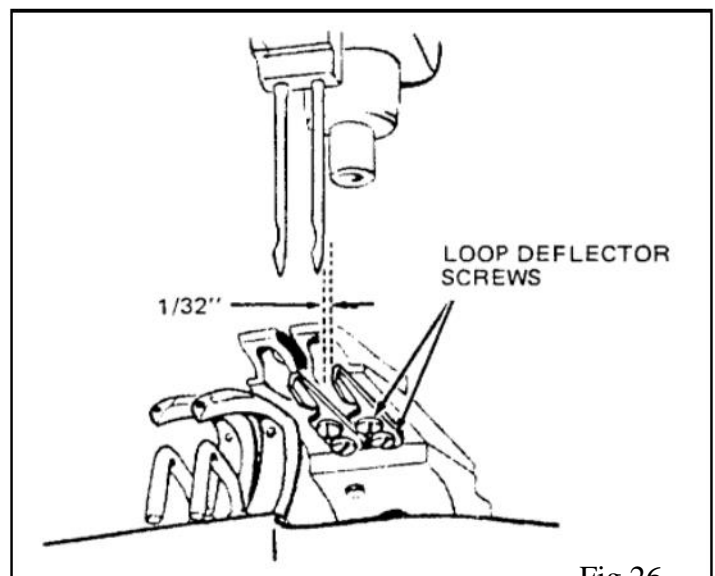
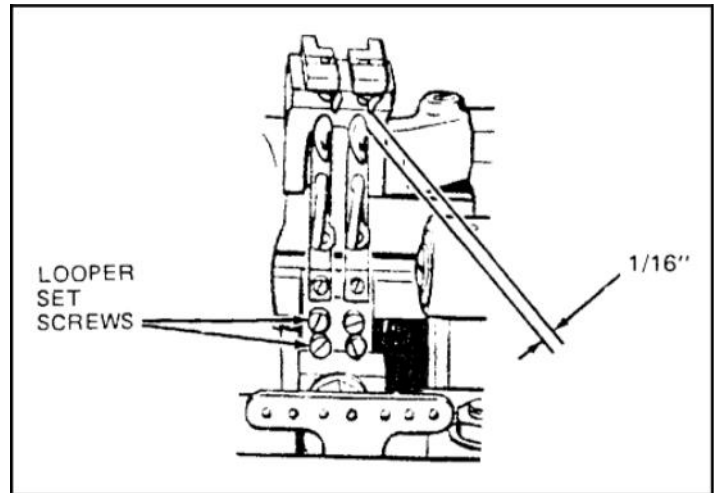
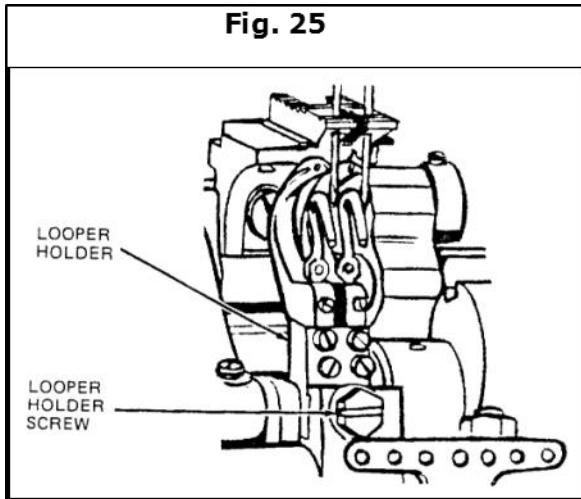

Fig 26

Setting the Distance from the Looper to the Needle



Sidewise Setting

When the looper is correctly positioned, the point of the looper just clears the scarf of the needle on the forward stroke of the looper. To adjust, turn the machine pulley until the looper point is directly opposite of the center of the needle. Loosen the looper holder screw, Fig. 25, and tap the holder to the left or right until the correct clearance is attained. Then securely tighten the looper holder screw.

Move the looper to the extreme forward position. Check the clearance between the heel of the looper and the loop deflector, Fig. 26, which should be approximately 1/16". To adjust, loosen the two looper set screws. Turn the looper to the left or right until the correct clearance is attained. Hold in position and securely tighten the two set screws.

Caution: On single and multi-needle machines, make certain that the point of each looper just clears the scarf of its respective needle. To adjust, with the looper point directly opposite the center of the needle, loosen the two set screw, Fig. 26, and turn the looper slightly to the left or right. Then tighten the set screws.

Lengthwise Setting & Setting the Height of the Needle Bar

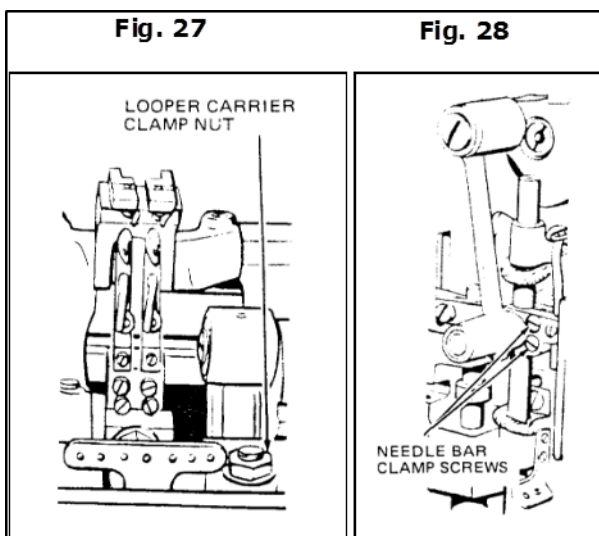

When correctly set: the point of the looper should be directly opposite of the center of the needle, and at the center of the clearance above the eye of the needle when the looper timing mark LT on the machine pulley is opposite of the timing arrow on the arm.

To adjust the looper, loosen the looper carrier clamping nut, Fig. 27. Move the carrier forward or backward until the looper point is directly opposite of the center of the needle. Then tighten the clamping nut.

To adjust the needle bar, first make certain that the needle is inserted up into the needle bar or clamp as far as possible. Loosen the two needles bar clamping screws, Fig. 28, and raise or lower the needle bar to correct position. Then tighten the clamping screws.

Timing Looper Driving Crank

When the looper driving crank is properly timed, the point of the looper will pass above the eye of the needle at the same distance on both the forward and backward strokes of the looper.

To adjust when the point of the looper passes higher on the forward stroke, loosen the looper driving crank set screw, Fig. 29. Loosen the looper crank timing screw (left) approximately 1/8 turn and tighten the looper crank timing screw (right). Continue to adjust until the correct adjustment is made. Then securely tighten the set screw.

When the point of the looper passes higher on the backward stroke, reverse the adjustment by loosening the timing screw (right) and tightening the timing screw (left).

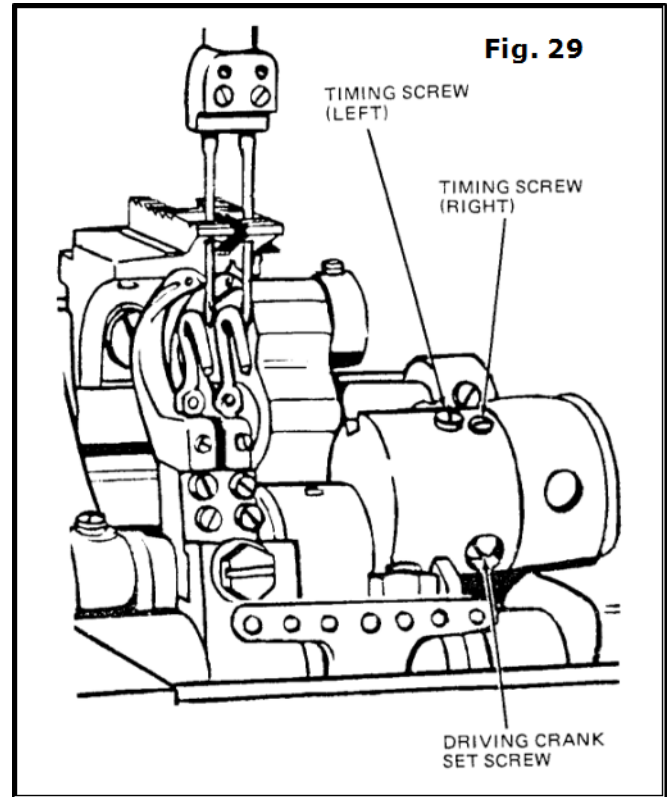
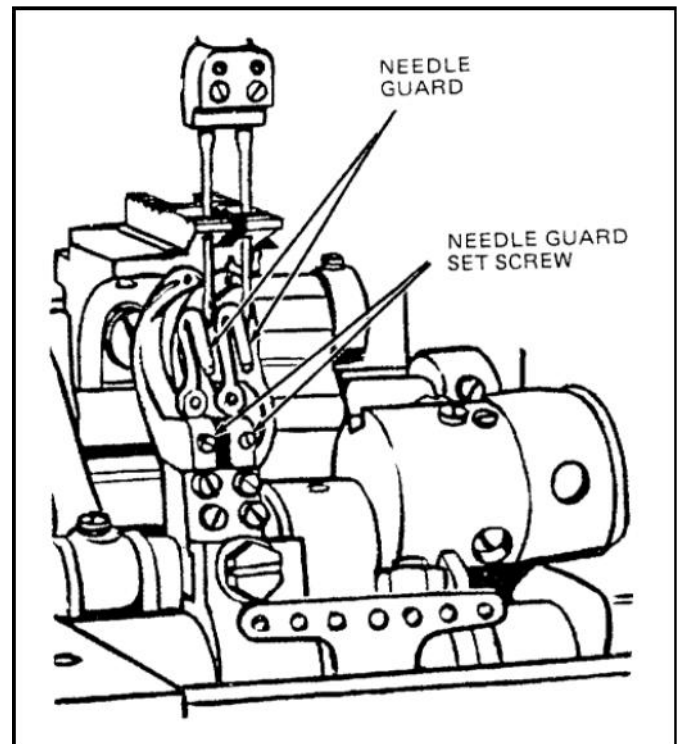

Fig. 30

Setting the Needle Guards

When the needle guards are properly set, they should pass as close as possible to the needles without touching. To adjust the guard, turn the machine pulley over toward the operator until the points of the loopers are about to pass the needles on their forward strokes. At this point, the looper timing mark LT on the machine pulley should be approximately 1/8" above the arrow on the machine arm. Loosen the needle guard set screws, Fig. 30. Turn the needle guards as close to the needles as possible without touching. Tighten the set screws. Check by springing the needles to the left and turning the machine pulley to make certain that the looper points do not stroke the needles.



Positioning Spreader

Fig 31

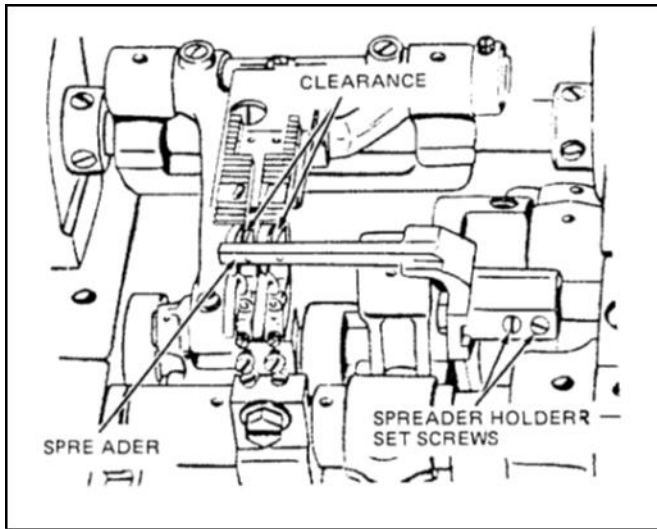
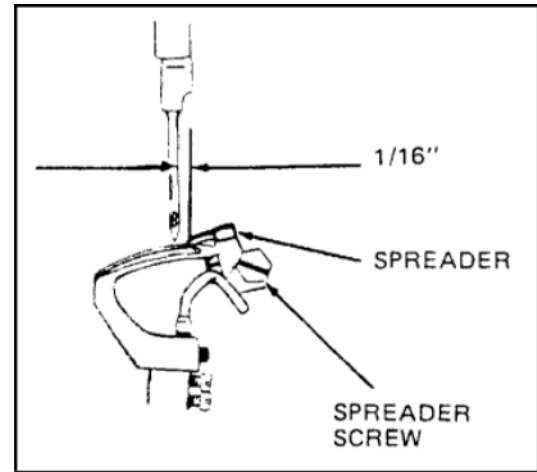

Fig 32



Sidewise and Height Setting

When the looper on its forward stroke is passing the spreader

- a) The point of the spreader should be exactly opposite the top of the thread groove at the left side of the looper.
- b) The clearance between the spreader point and the looper should be approximately the double thickness of ordinary paper.

To adjust, loosen the two-spreader holder set screw, Fig. 31. Move the spreader and holder to the correct position. Hold in position and tighten the set screws.

Lengthwise Setting

When the point of the needle on its downward stroke is even with the point of the spreader, the clearance between the two points should be approximately 1/16". To adjust, loosen the spreader screw, Fig. 32, and move the spreader forward or backward to correct position. Then tighten the spreader screw.

Fig 33

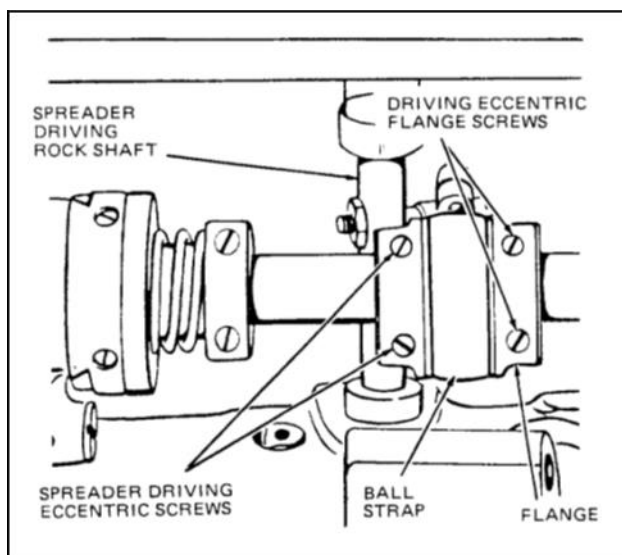

Changing Movement of Spreader

The sidewise movement of the spreader may be adjusted for sewing under abnormal conditions. Under normal conditions, maximum spreader movement is generally used. To adjust, tilt the machine back on its hinges, loosen the two spreader driving eccentric screws, Fig. 33, and the two spreader driving eccentric flange screws. Move eccentric to the left to increase movement, or to the right to decrease movement. When correctly positioned, tighten the two spreader driving eccentric screws first, hold flange against strap and tighten flange screws. Then refer to preceding information regarding positioning of spreader.

The needle thread take-up and thread guide may be adjusted to increase or decrease the amount of thread drawn at the top of the needle bar stroke. To increase the amount, loosen the thread take-up screw, Fig. 34, and raise the take-up or loosen the guide screw and lower the guide. To decrease the amount, reverse the adjustment by lowering the take-up or raising the guide.

For average sewing conditions, the guide should be set with upper end 5/8" above the guide screw. The thread take-up should be set with the lower end 1.378" below the bottom of its holder.

Adjusting Needle Thread Tension Releaser

When correctly adjusted, the tension releaser should release tension on the needle thread when the presser foot is raised and allow full adjusted tension when presser foot is down. To adjust, loosen the set screw, Fig. 35, and move tension releaser cap out for earlier release of tension or in for later release. Hold in position and tighten the set screw. Should the tension releaser not release tension at the correct time after making the above adjustments, loosen the tension releaser plate screw and move plate sidewise to correct position. Then tighten the screw.

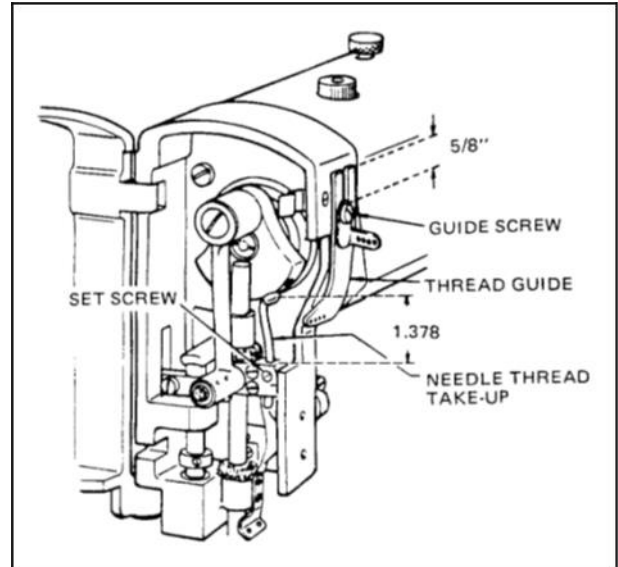

Fig 35

Adjusting Loper Thread Take-Up

The looper thread take-up and guide may be adjusted for handling more or less thread, according to the thickness of material and length of . stitch, and to change the ratio of looper thread in the finished stitch.

To change the amount of thread handled, loosen the looper thread guide screw, Fig. 36, and

looper thread take-up rod screw. Move the thread guide and take-up rod to the left for more thread or to the right for less thread. Tighten the two screws making certain that the take-up rod passes through the center of the guide yoke.

To change the ratio of looper thread in finished stitch, loosen the thread guide screw, Fig. 36, and lower the yoke or right end of the thread guide for more thread. For less thread, raise the end of the guide. Hold in position and tighten the guide screw.

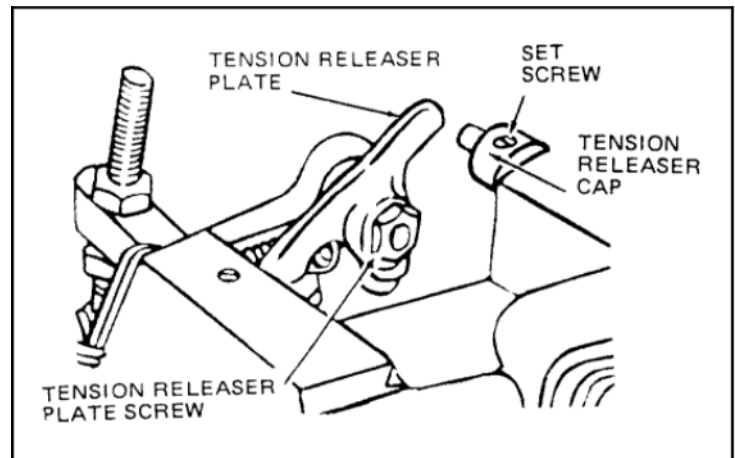
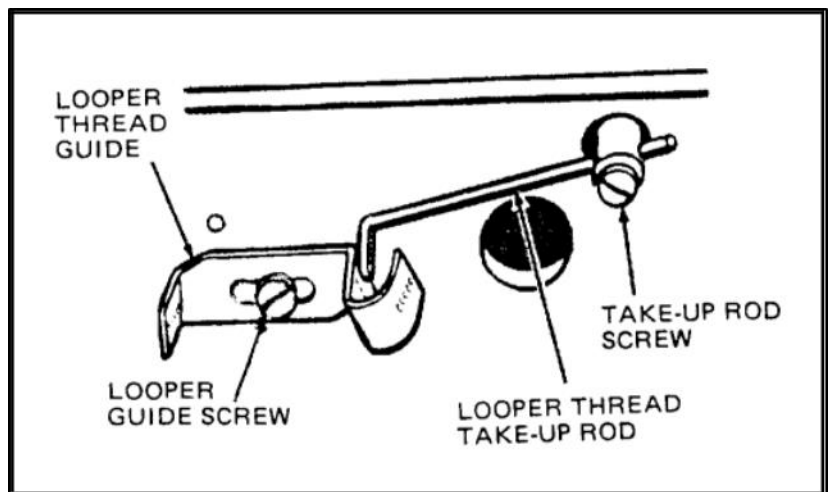

Fig 36



Notes :

AAC 300UX6 Assembly Drawings & Parts Lists



Atlanta Attachment Company is the exclusive stocking distributor for AAC Tape Edge Sewing Heads and recommended spare parts for AAC Tape Edge machines.

We can also supply proprietary parts in most cases for Cash*, Spuhl*, Porter, United* Tape Edge workstations.

Orders may be placed by:
Phone: 770-963-7369
Fax: 770-963-7641
Email: sales@atlatt.com

*Cash, Spuhl, Porter, and United are the trademarks of their respective companies.

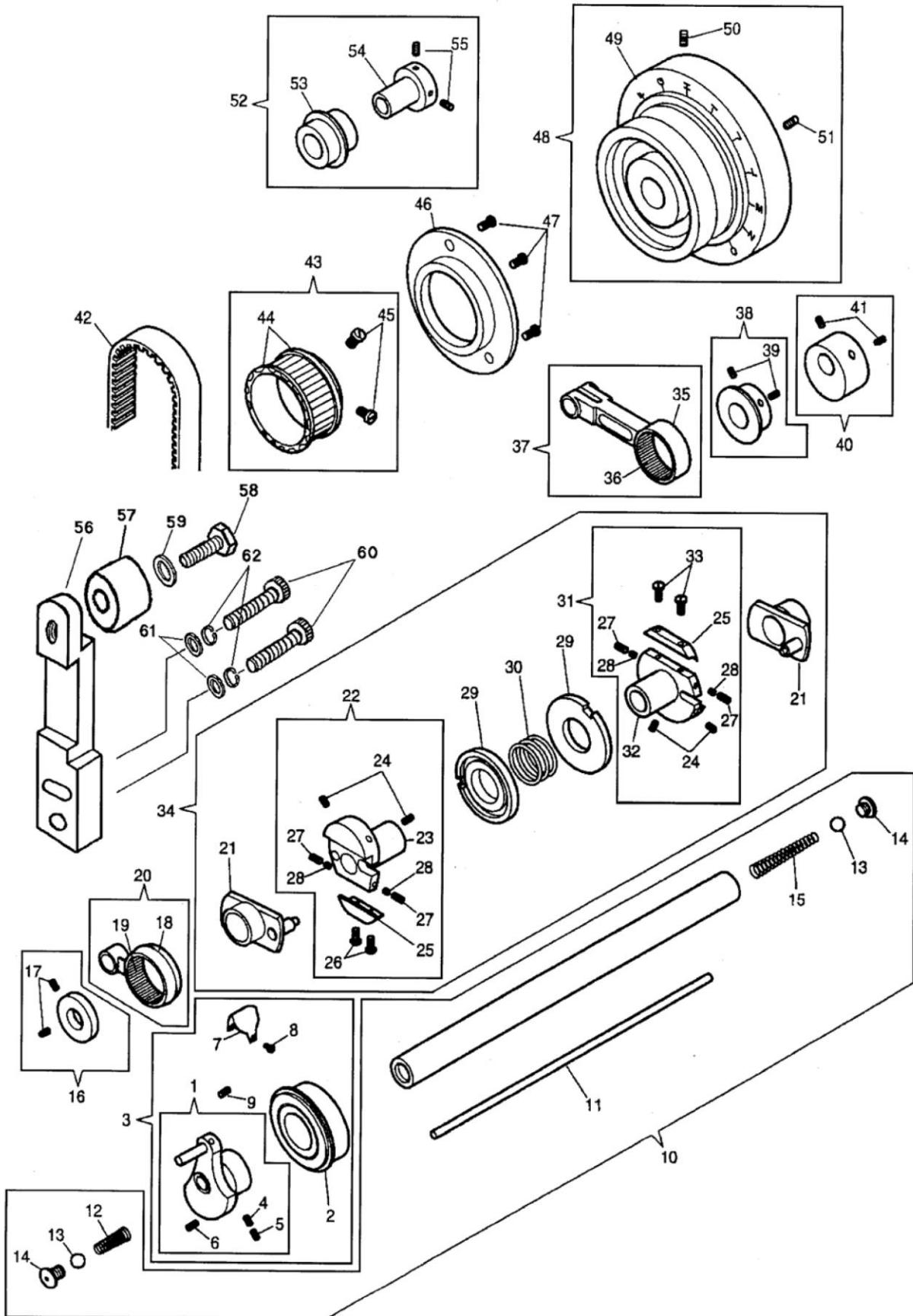

Upper Shaft Assembly

NO.	PART #	DESCRIPTION	NO.	PART #	DESCRIPTION
1	415138	CRANK, NEEDLE BAR	32	415077	LIFTING ECC FLANGE
2	32848	BEARING	33	374098	SCREW
3	2812239	NEEDLE BAR CRANK COMPLETE	34	415081	ECCENTRIC COMP
4	549024	SCREW	35	268491	LIFTING ECCENTRIC
5	544358	SET SCREW	36	271055	FEED DRIVING CONNECTION NEEDLE
6	500272	NEEDLE BAR CRANK SCREW	37	268491	LIFTING ECC CONN
7	281206	CRANK COVER	38	415086	SPACE COLLAR
8	545205451	SCREW, WHITE	39	414529	SCREW
9	281258	NEEDLE BAR CRANK OIL PACKING (40	281256	BALANCE WEIGHT CPL
10	415128	ARM SHAFT	41	544208005	SCREW
11	268264	ROD, OIL CONTROL	42	268270	CONNECTION BELT
12	415200	SPRING	43	281290	PULLEY
13	268214	BALL, OIL STOP	44	202253	SPRING FLANGE
14	414578	BALL SCREW	45	414546	SCREW
15	268044	SPRING, OIL STOP BALL	46	268004451	HOUSING
16	415308	SPACING COLLAR	47	544336	STUD SCREW
17	414529	SCREW	48	281296467	MACHINE PULLEY (W/414525 & 414
18	271055	FD DRIVE CONN	49	281297467	MACHINE PULLEY
19	271055	FEED DRIVING CONNECTION NEEDLE	50	414525	SCREW
20	267609	FEED DRIVING CONN	51	414526	SCREW
21	267610	FEED DRIVE ECC	52	281294	ARM SHAFT THRUST COLLAR
22	415078	ECCEN FLANGE CPL	53	272142	BALL BEARING
23	415078	ECCENTRIC FRANGE	54	281295001	BED SHAFT THRUST COLLAR
24	414555	SCREW	55	544209005	SET SCREW
25	267623	FRICTION PLATE	56	KE0022	BELT TENSION BRACKET
26	374098	SCREW	57	KE0023	CAM FOLLOWER
27	414557	SCREW	58	KE0074	CAM FOLLOWE SCREW
28	241763	PACKING FIBRE	59	KE0082	CAM FOLLOWER SCREW WASHER
29	268065	ECC ADJUSTING DISC	60	414753004	BELT TENSION BRACKET SET SCREW
30	267618	ADJUSTING DISC SPR	61	270 543803005	WASHER
31	415076	LIFT ECC FLANGE CPL	62	270 543805005	WASHER

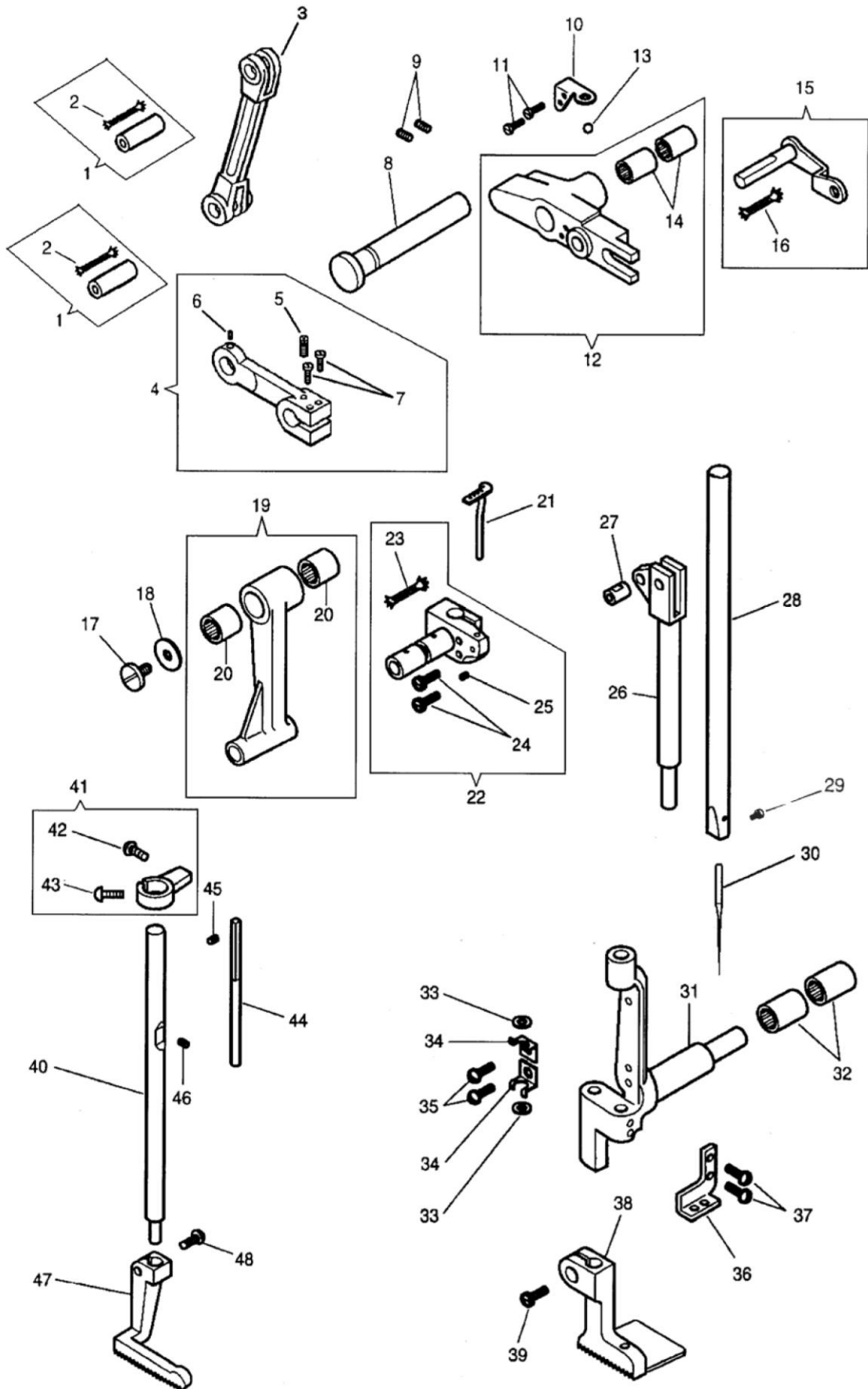

Front Assembly Sewing Arm

NO.	PART #	DESCRIPTION	NO.	PART #	DESCRIPTION
1	267617	LINK HINGE PIN	25	414545	SET SCREW
2	268258	PACKING WICK	26	267657	VIB PRESSER BAR
3	267627	LIFTING LINK	27	267658	VIBRATING PRESSER BAR HINGE ST
4	415061	LIFTING CRANK	28	281912	NEEDLE BAR
5	141338	SCREW	29	414519	SCREW
6	141424	SCREW	30		SINGER NEEDLE 62x59 size 23
7	414511	SCREW	31	415045	FRAME, NEEDLE BAR
8	267626	HINGE STUD	32	268029	NEEDLE BEARING
9	544322	SET SCREW	33	268144	N BAR OILING FELT
10	267718	PRESSER BAR SPRING ARM BALL RE	34	268278	OILING FELT HOLDER
11	414548	RETAINER SCREW	35	414522	SCREW
12	415067	Lifting lever	36	268219	THREAD GUIDE
13	276025	BALL, PRESSER BAR SPRING ARM	37	414539	SCREW
14	KE0008	LIFTING LEVER BUSHING	38	KE0069	VIBRATING PRESSER FOOT
15	267631	PR BAR LIFT CRANK	39	414638	SCREW
16	268258	PACKING WICK	40	267628	LIFTING PR BAR
17	414517	SCREW	41	415059	GUIDE BLOCK
18	268139	WASHER	42	414516	SCREW
19	281916	NEEDLE BAR CONNECTING LINK (30	43	414512	SCREW
20	270266	NEEDLE BEARING (GBH68)	44	267907	GUIDE ROD
21	268512	THREAD GUIDE	45	544301	SCREW
22	281914	NEEDLE BAR CONNECTING STUD CPL	46	414530	SCREW
23	202330	OIL WICK	47	559059	LIFTING PRESSER FOOT
24	414511	SCREW	48	414638	SCREW

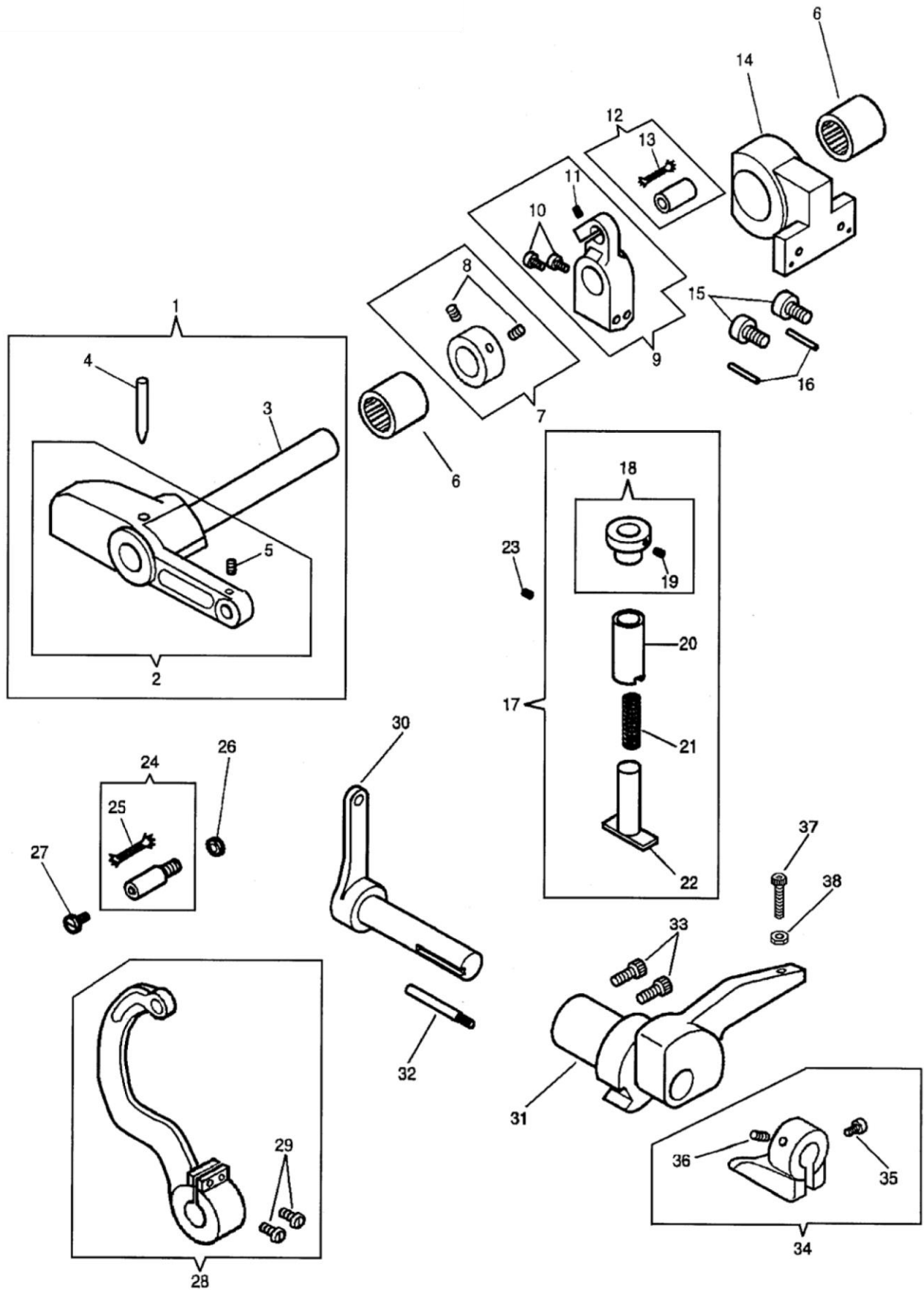

External Parts Sewing Arm #1

NO.	PART #	DESCRIPTION
1	32788	ROCK SHAFT
2	32788	ROCK SHAFT
3	32789	ROCK SHAFT
4	548035	PIN
5	141424	SCREW
6	267110	NEEDLE BEARING,GBH-78
7	415065	COLLAR COMP
8	504020	SCREW (300UX5)
9	415069	CONN CRANK
10	414509	SCREW
11	374362	SUBSTITUTION REQUIRED
12	267617	LINK HINGE PIN
13	268258	PACKING WICK
14	415071451	LIFTING ROCK SHAFT BRACKET
15	414504	SCREW
16	543841001	PIN
17	415098	STUD COMP
18	415099	STUD CAP
19	414528	SCREW
20	268149	ROCK SHAFT SLEEVE (300UX5)
21	214529	SPRING
22	268148	STUD
23	414527	SCREW
24	415091	HINGE STUD
25	268258	PACKING WICK
26	541197	NUT
27	545297	SCREW
28	415094451	NEEDLE BAR ROCK FRAM DRIVING ARM
29	414790	SCREW
30	267612	CRANK, FOOT LIFT
31	267719452	ARM FULCRUM (WHITE)(HIGH LIFT)
32	414566	SCREW STUD
33	350604	SCREW
34	415122	FT L ARM COMP
35	414509	SCREW
36	545213	SET SCREW
37	414750004	PRESSER BAR SPRING ARM FULCRUM
38	541166001	NUT

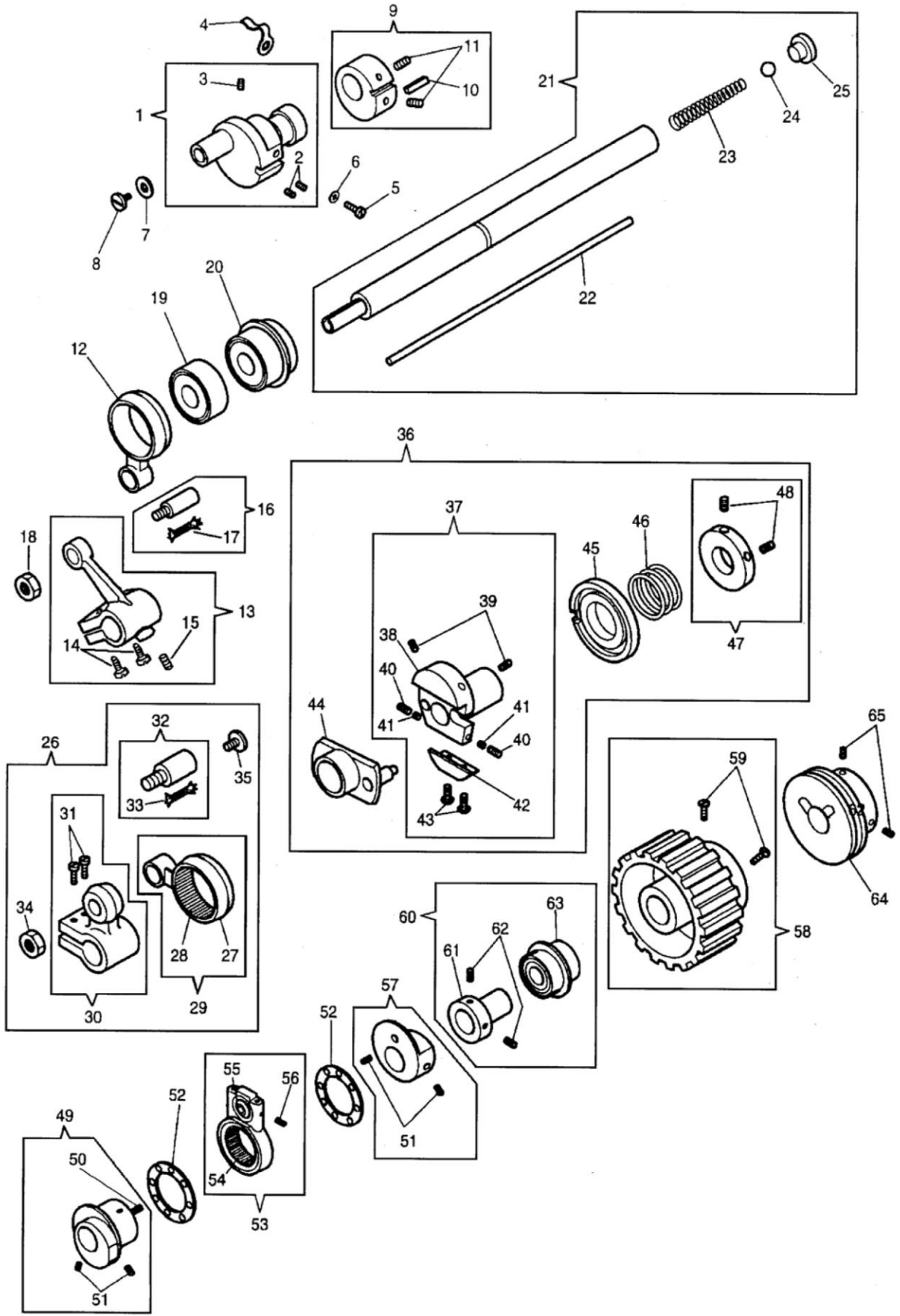

Lower Shaft Assembly

NO.	PART #	DESCRIPTION	NO.	PART #	DESCRIPTION
1	415176	DRIVE CRANK	34	541197	NUT
2	374099	SCREW	35	545297	SCREW
3	500264833	LOOPER DRIVING CRANK SET SCREW	36	415082	ECCENTRIC COMP
4	268102	COVER, OIL HOLE	37	415073	FEED DRIVING ECC FLANGE
5	414563	SCREW	38	415073	SUBSTITUTION REQUIRED
6	204925	SPRING STUD WASHER(5)	39	414555	SCREW
7	268139	WASHER	40	414557	SCREW
8	200100	SCREW	41	241763	PACKING FIBRE
9	415210	FEED LIFT ECCEN	42	267623	FRICTION PLATE
10	268077	LUBRICATING PAD	43	374098	SCREW
11	544208005	SCREW	44	267610	FEED DRIVE ECC
12	268074	FD LIFT CONNECTION	45	268065	ECC ADJUSTING DISC
13	415206	ROCK SHAFT CRANK	46	268066	ADJUSTING DISC SPR
14	414511	SCREW	47	412011	SPRING COLLAR
15	414549	SCREW	48	544325	SET SCREW
16	415091	HINGE STUD	49	415187	SPREADER DRIVING ECCENTRIC
17	268258	PACKING WICK	50	543808002	PIN
18	541197	NUT	51	414528	SCREW
19	281216	BED SHAFT BALL BEARING	52	268220	THRUST WASHER
20	281224	BED SHAFT BALL BEARING	53	281246001	SPREADER DRIVING ECC CPL
21	559038	BED SHAFT CPL	54	415368	NEEDLE BEARING (300UX5)
22	268265	CONTROL ROD	55	281248	SPRD DR RCK SHFT SCR STD BALL
23	268044	SPRING, OIL STOP BALL	56	544203001	SCREW
24	268214	BALL, OIL STOP	57	415190	COUNTER BALANCE (300UX5)
25	414578	BALL SCREW	58	281292	BED SHAFT CONNECTION BELT PULL
26	415215	DRIVE SHAFT COMP	59	414546	SCREW
27	271055	FD DRIVE CONN	60	281294	ARM SHAFT THRUST COLLAR
28	271055	FEED DRIVING CONNECTION NEEDLE	61	281295001	BED SHAFT THRUST COLLAR
29	267609	FEED DRIVING CONN	62	544209005	SET SCREW
30	415213	SHAFT CRANK	63	272142	BALL BEARING
31	414511	SCREW	64	KE0038	BED SHAFT PULLEY
32	415091	HINGE STUD	65	544209005	SET SCREW
33	268258	PACKING WICK			

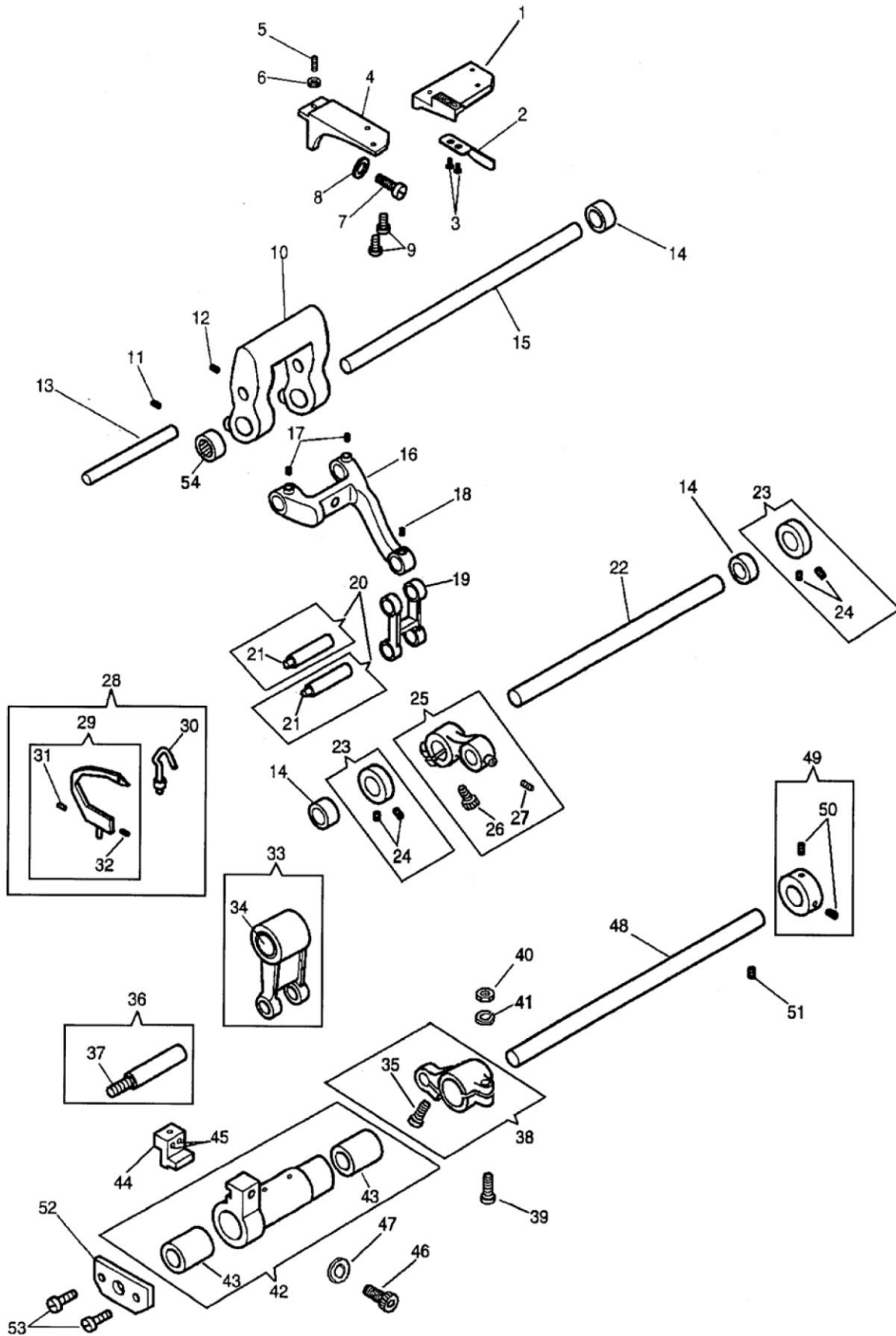

Front Assembly Sewing Bed

NO.	PART #	DESCRIPTION	NO.	PART #	DESCRIPTION
1	559061	FEED DOG	28	281208	LOOPER COMPLETE WITH GUARD
2	267665	LOOP DEFLECTOR	29	268382	LOOPER ONLY (ORDER 281207 FOR
3	229	SCREW, LOOP DEFL	30	281207	NEEDLE GUARD
4	559064	FEED DOG SHANK	31	141478	SCREW
5	414559	SCREW	32	141494	SCREW
6	541200	LOCK NUT	33	281223	LOOPER DRIVING CONNECTION CPL
7	414750002	SCREW	34	415500	BUSHING
8	543804004	WASHER	35	414516	SCREW
9	374107003	SCREW	36	268208	CRANK HINGE PIN
10	559049	FEED DRIVE ROCK FRAME	37	268258	PACKING WICK
11	549024	SCREW	38	415174	LOOPER CARR CR CPL
12	500264833	FEED DRIVING ROCK FRAME SET SCREW	39	415292	CLAMPING STUD
13	559051	FEED BAR HINGE PIN	40	541198	NUT
14	415297	BUSHING	41	548459	WASHER
15	268070	SHAFT, DRIVE ROCK	42	559041	LOOPER CARRIER
16	559045	FEED BAR	43	415500	BUSHING
17	270 544204001	SCREW	44	559055	LOOPER HOLDER CPL
18	545213	SET SCREW	45	414558	SCREW
19	268078	FEED LIFTING LINK	46	414750002	SCREW
20	268079	LINK HINGE PIN	47	543804004	WASHER
21	268258	PACKING WICK	48	269617	CARRIER SHAFT
22	559052	FEED LIFTING ROCK SHAFT	49	415172	SHAFT COLLAR
23	415065	COLLAR COMP	50	270 544204001	SCREW
24	504020	SCREW (300UX5)	51	544209003	SCREW
25	415204	CRANK	52	559044	LOOPER CARRIER SHAFT SUPPORTIN
26	414501	SCREW	53	200100	SCREW
27	545213	SET SCREW	54	415297	NEEDLE BEARING

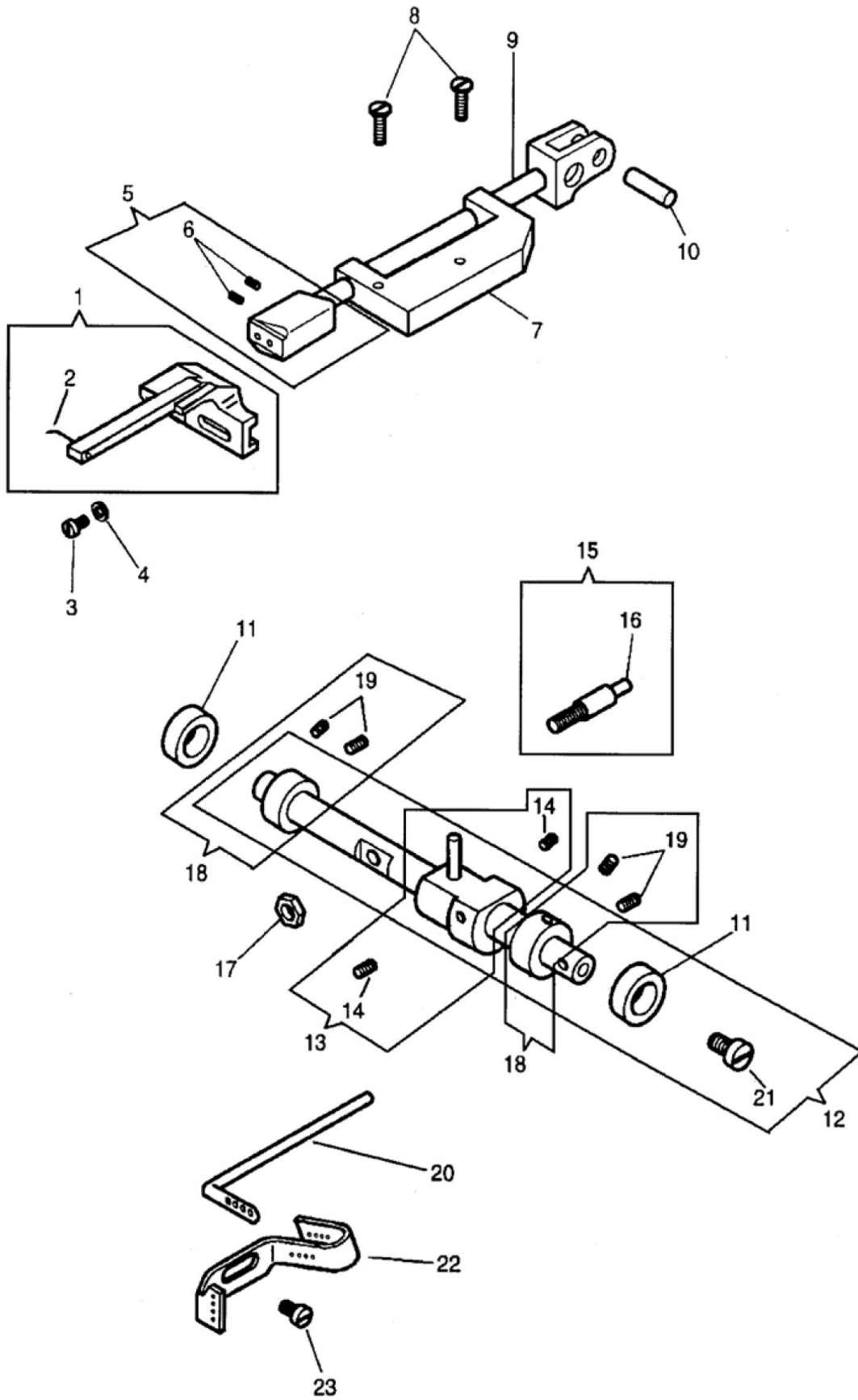

Cross Shaft in Sewing Bed

NO.	PART #	DESCRIPTION
1	281975	SPREADER
2	268162	SPREADER POINT
3	414552	SCREW
4	547670	WASHER
5	415196	SPREADER HOLDER
6	414529	SCREW
7	268184	SPREADER BAR BRACKET
8	414524	SCREW
9	559065	SPREADER BAR
10	268190	SPREADER DRIVE PIN
11	415297	BUSHING
12	415389	ROCK SHAFT
13	415194	CRANK COMP
14	270 544204001	SCREW
15	281249	SPREADER DRIVING ROCK SHAFT SC
16	32825	OIL WICK
17	545424	NUT
18	415065	COLLAR COMP
19	504020	SCREW (300UX5)
20	268052	LOOPER TAKE UP ROD
21	545385	SCREW
22	269619	THREAD GUIDE
23	414510	SCREW

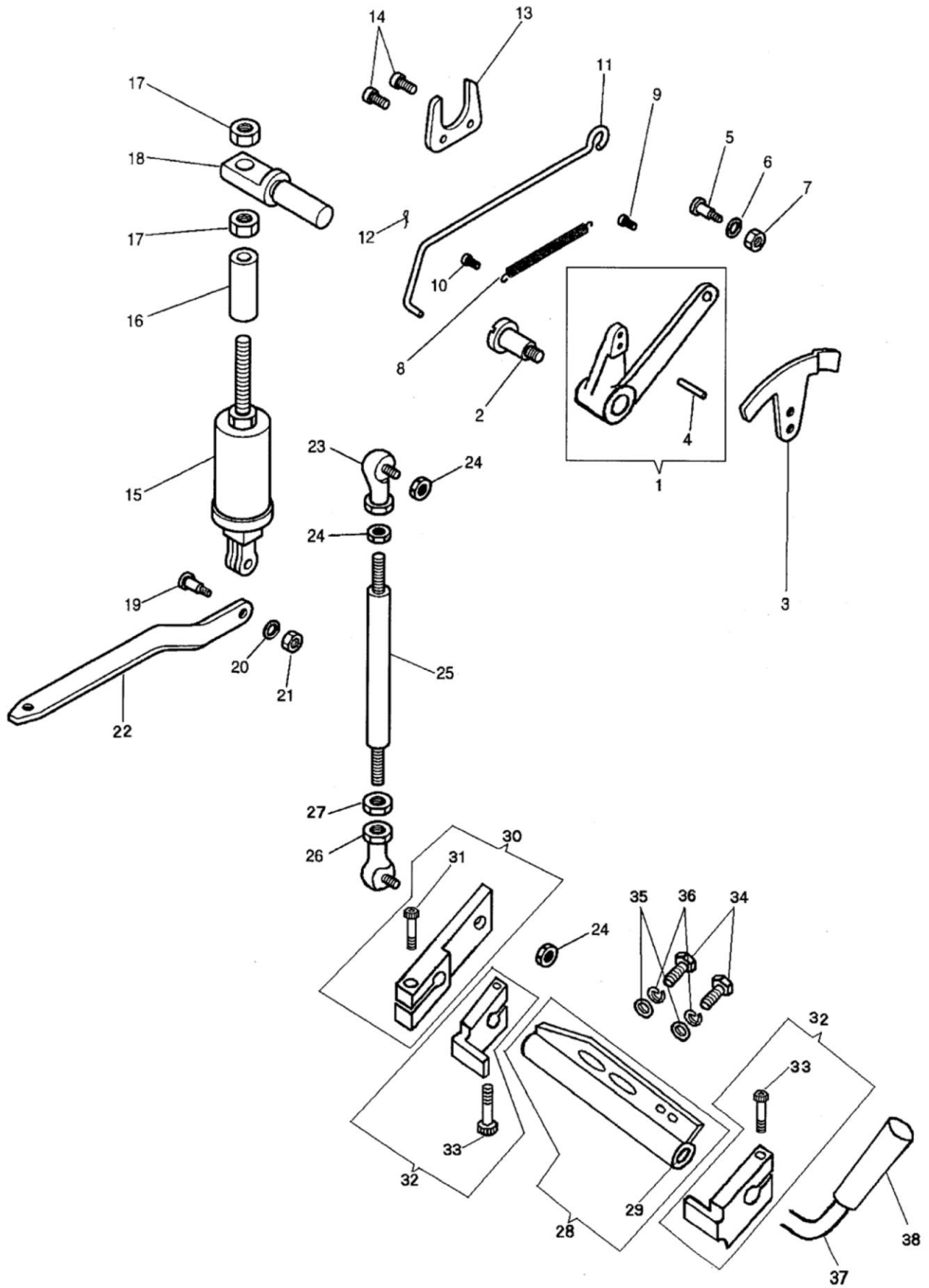

External Parts Sewing Arm #2

NO.	PART #	DESCRIPTION
1	KE0085	FOOT LIFTER LEVER
2	201363	SCREW 300W
3	267707	RELEASING PLATE
4	543850001	PLATE PIN
5	414577	HINGE SCREW
6	543804004	WASHER
7	541166003	NUT
8	204348	SWITCH SPRING
9	414570	SCREW
10	544336	STUD SCREW
11	267704	LIFTER LEVER ROD
12	248423	COTTER PIN
13	267650	RETAINER
14	545205451	SCREW, WHITE
15	415106	PRESSER BAR SPRING HOUSING ASS
16	559077	PRESSER BAR SPRING HOUSING COL
17	541198	NUT
18	267714	HOUSING SUPPORT
19	414567	HINGE SCREW
20	548154	SCREW WASHER
21	545405	NUT
22	267738	PR BAR SPR ARM
23	412373	CONNECTION (UPPER)
24	541166001	NUT
25	559068	LIFTING ROD
26	559067	LIFTING ROD CONNECTION (LOWER)
27	414774	NUT
28	KE0026	FOOT LIFT PIVOT COMPLETE
29	KE0030	BUSHING
30	KE0083	FOOT LIFT LEVER COMPLETE
31	414753004	BELT TENSION BRACKET SET SCREW
32	KE0084	STOP COLLAR COMPLETE
33	414750004	PRESSER BAR SPRING ARM FULCRUM
34	544499072	SCREW
35	270 543803005	WASHER
36	270 543805005	WASHER
37	KE0034	PIVOT ARM
38	KE0035	HANDLE

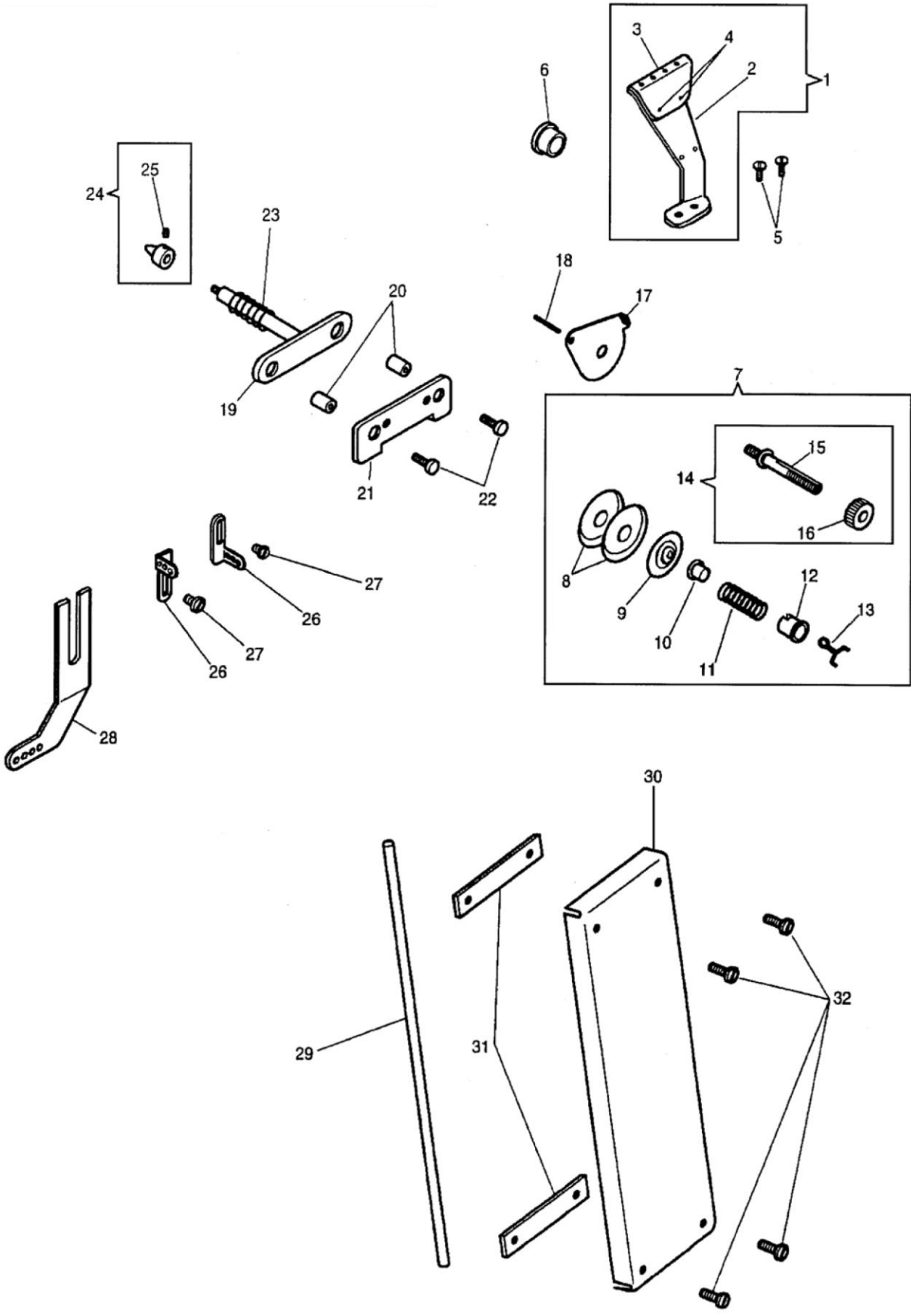

External Parts Sewing Arm #3

NO.	PART #	DESCRIPTION
1	268506	TH GUIDE BRACKET
2	268111	LOOPER BRACKET
3	268505	LOOPER TH GUIDE
4	50169	SCREW (5)
5	414537	SCREW
6	544875	PLUG
7	267971	THREAD TENSION
8	HA046072	TENSION DICS
9	32572	TENSION DISC (5)
10	59538	SPRING BUSHING
11	131741	TENSION SPRING
12	143657	BUSHING
13	143658	LOCKING SPRING
14	59539	TENSION SCREW STUD
15	59539	TENSION SCREW STUD
16	51570	NUT
17	54279	THREAD GUIDE
18	226206	LATCH SPRING PIN
19	415357	TENSION RELEASER
20	543853003	NEEDLE THREAD TENSION BRACKET
21	268167	TENSION BRACKET
22	544336	STUD SCREW
23	204365	SPRING
24	415252	RELEASER CAP
25	504048	SCREW
26	268513	N THREAD GUIDE
27	414514	SCREW
28	268312	THREAD GUIDE
29	268123	THREAD TUBE
30	415342451	LOOPER THREAD TUBE COVER
31	268500	GASKET
32	414639	GUIDE SCREW

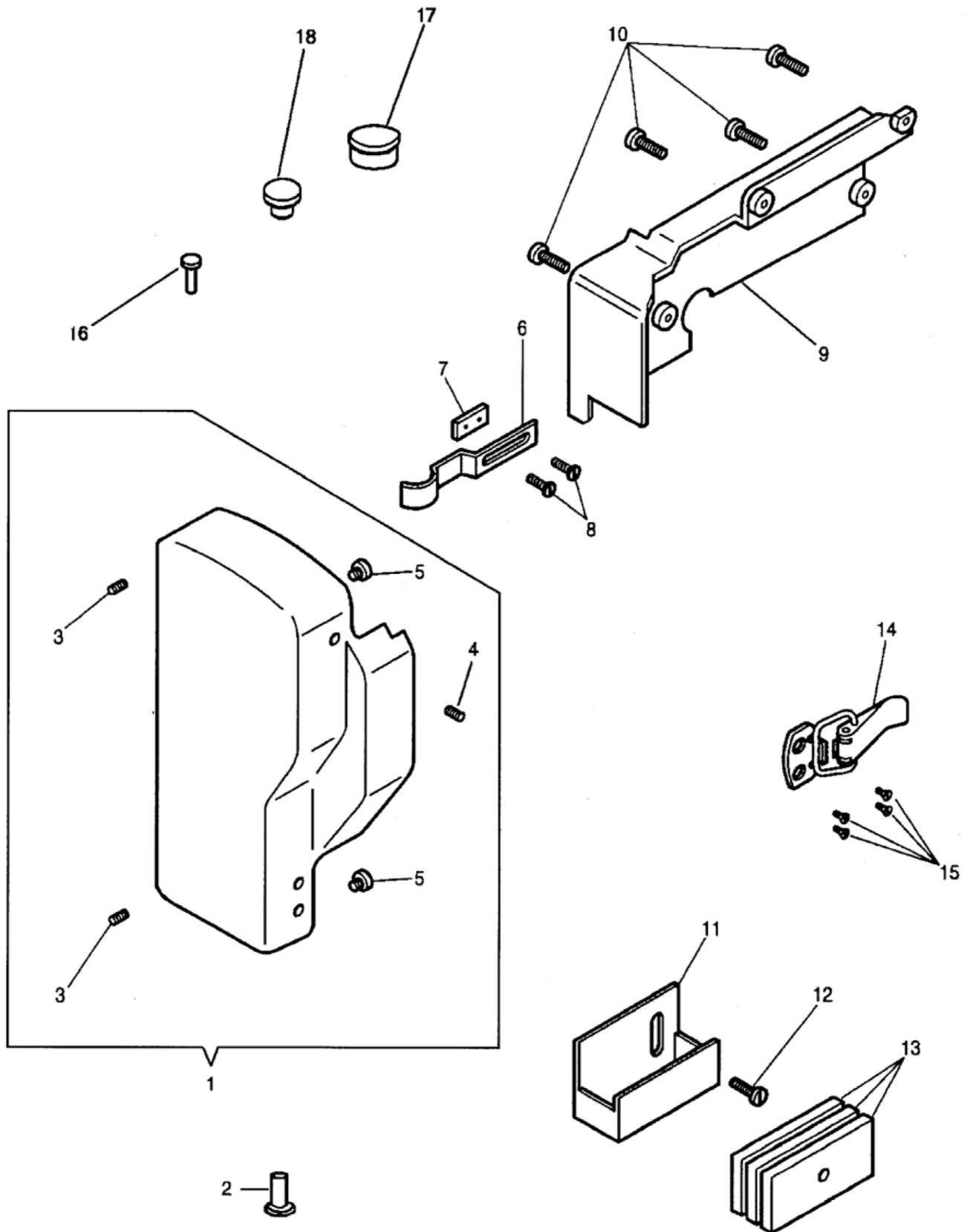

External Parts Sewing Arm #4

NO.	PART #	DESCRIPTION
1	KE0021	FACE PLATE (WITH 268033)
2	268330	FACE PLATE HINGE STUD
3	544053	SET SCREW
4	268033	LOCK STUD
5	228661	COVER CUSHION
6	268032	LOCK SPRING
7	415016	SPRING PLATE
8	414534	SCREW
9	KE0072	ARM SIDE COVER
10	545295	SCREW
11	267656452	THREAD LUBRICATOR
12	545385	SCREW
13	236957	OIL PAD,THREAD LUBRICATOR (FEL
14	559032	FACE PLATE LOCKER
15	374397002	FACE PLATE LOCKER SCREW
16	KE0007	FACE PLATE HINGE STUD
17	544875	PLUG
18	502986	PLUG

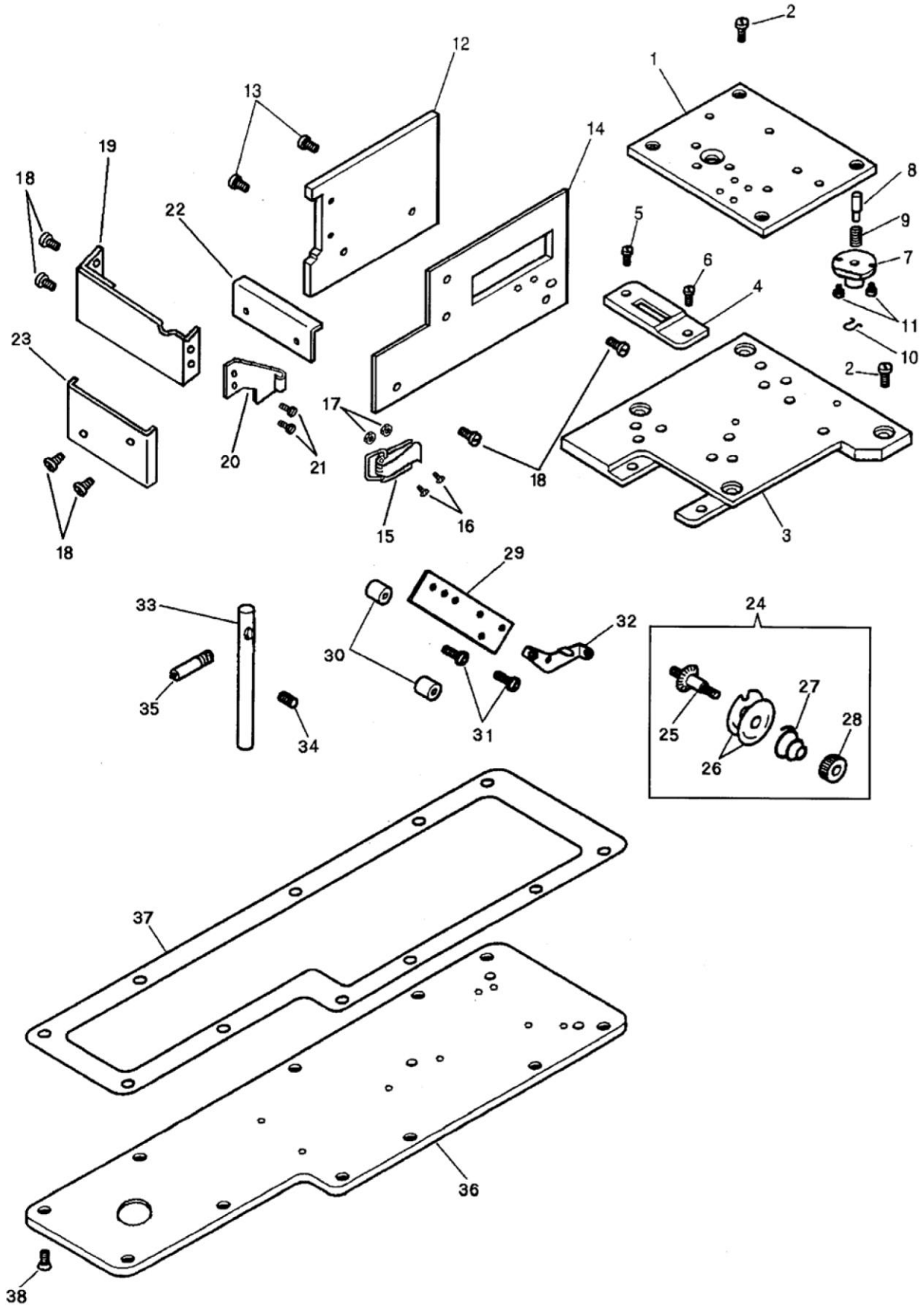

External Parts Sewing Arm #5

NO.	PART #	DESCRIPTION
1	KE0073	BED PLATE (RIGHT)
2	414508	SCREW
3	KE0037	BED PLATE (LEFT)
4	559060	THROAT PLATE
5	374107001	THROAT PLATE SCREW (BACK)
6	200100	SCREW
7	KE0075	FEED REGULATING STUD SOCKET
8	268081	STUD, FEED REG
9	270026	FEED REG STUD SPR
10	240245	RETAINING SPRING, (5PK)
11	545249452	FEED REGULATING STUD SOCKET SC
12	559075	BED COVER (BACK)
13	414520	SCREW
14	KE0068	BED COVER (FRONT)
15	KE0044	BED COVER (FRONT) LOCKER
16	270 544211051	STRIKER SCREW
17	541164001	NUT
18	544252	SET SCREW (300UX5)
19	KE0039	LOOPER COVER
20	KE0042	SNAP HOOK LATCH
21	544252	SET SCREW (300UX5)
22	559074	BED COVER (LEFT)
23	KE0043	END COVER
24	415294	TENSION COMP
25	415291	TENSION STUD
26	412203	TENSION DISC
27	10148	SPRING
28	541452	NUT
29	415255	TENSION BRACKET
30	543853003	NEEDLE THREAD TENSION BRACKET
31	414532	SCREW
32	268333	THREAD GUIDE
33	52239	LOOPER THREAD GUIDE
34	270 544211052	SCREW
35	559078	LOOPER THREAD GUIDE (PIPE)
36	KE0005	BOTTOM PLATE
37	559034	BOTTOM PLATE GASKET
38	414533	SCREW

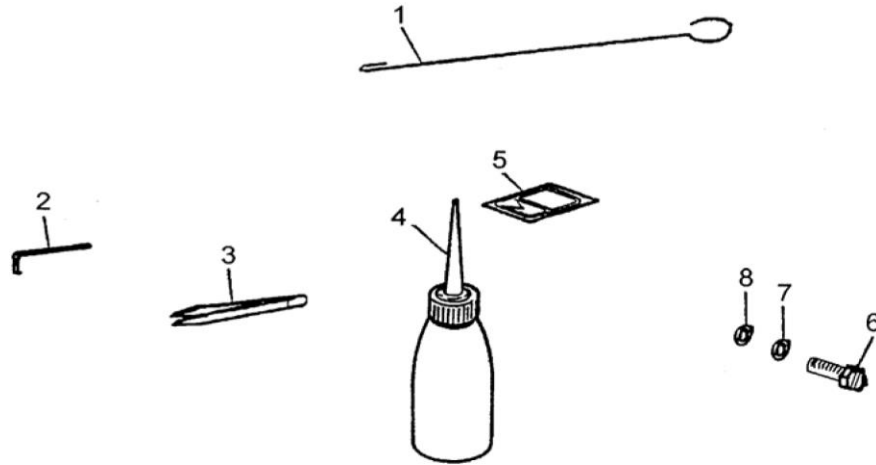

Accessories

NO.	PART NO.	DESCRIPTION
1	170 415377	THREADER WIRE
2	170 021887	WRENCH
3	270 BENTTWEEZER	BENT TWEEZERS, METAL
4	170 413448001	OILER
5	160 411201120	NEEDLE, 62X59
6	170 KE0015	BOLT
7	170 KE0016	WASHER
8	170 KE0017	SPRING WASHER

Assembly Drawings & Parts Lists

The materials contained herein are confidential and proprietary information of Atlanta Attachment Company. In addition to any confidentiality and non-disclosure obligations that currently exist between you and Atlanta Attachment Company, your use of these materials serves as an acknowledgment of the confidential and proprietary nature of these materials and your duty not to make any unauthorized use or disclosure of these materials.



One-Stop Shopping
For Expendable Replacement Parts for AAC & Other Bedding Equipment Suppliers
Toll Free: **1-866-885-5100**
www.atlantapartsdepot.com • sales@atlantapartsdepot.com

11315B Auto Tape Edge Machine

AAC Drawing Number 9008712 Rev 3

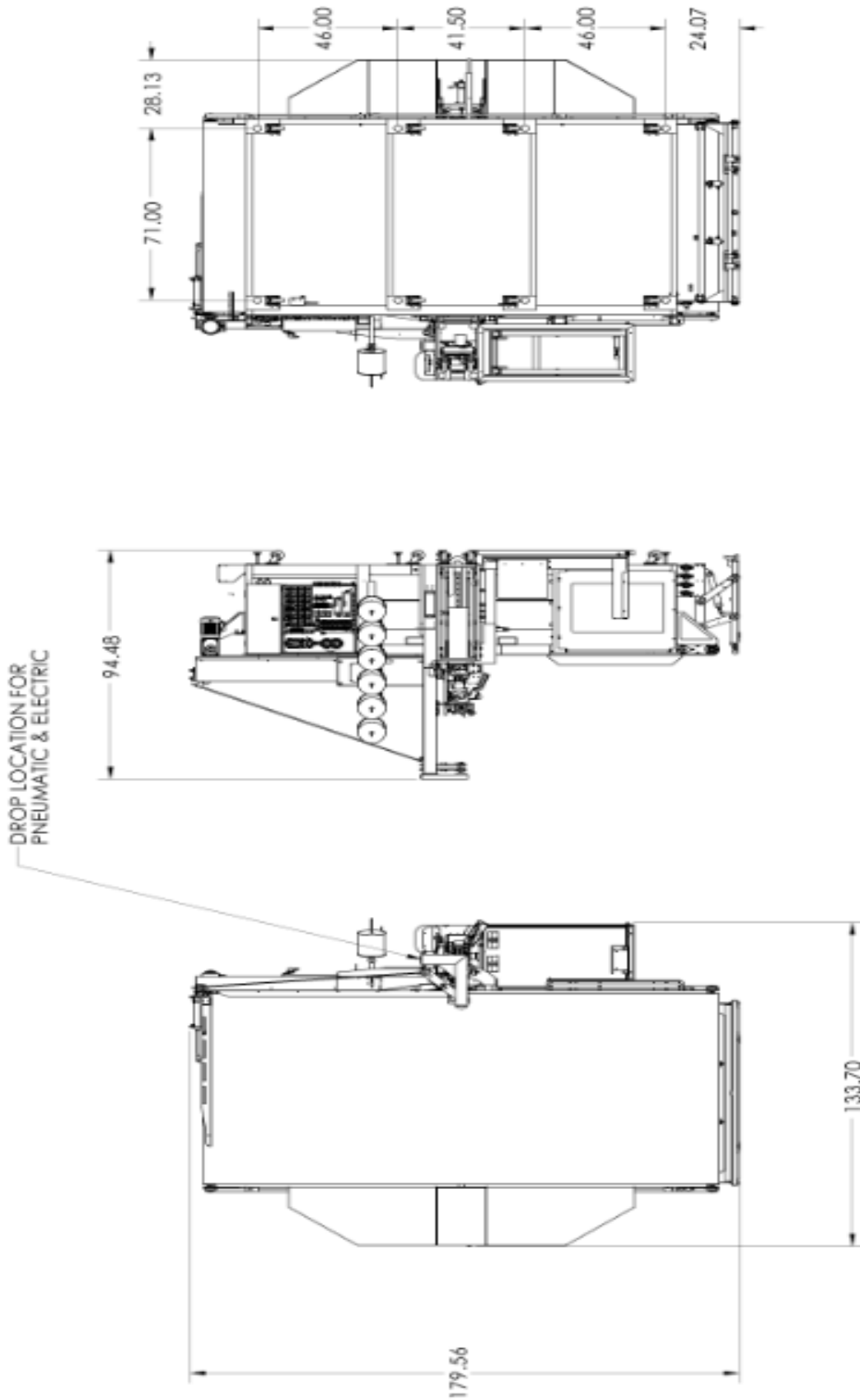

FOOTPRINT DRAWING

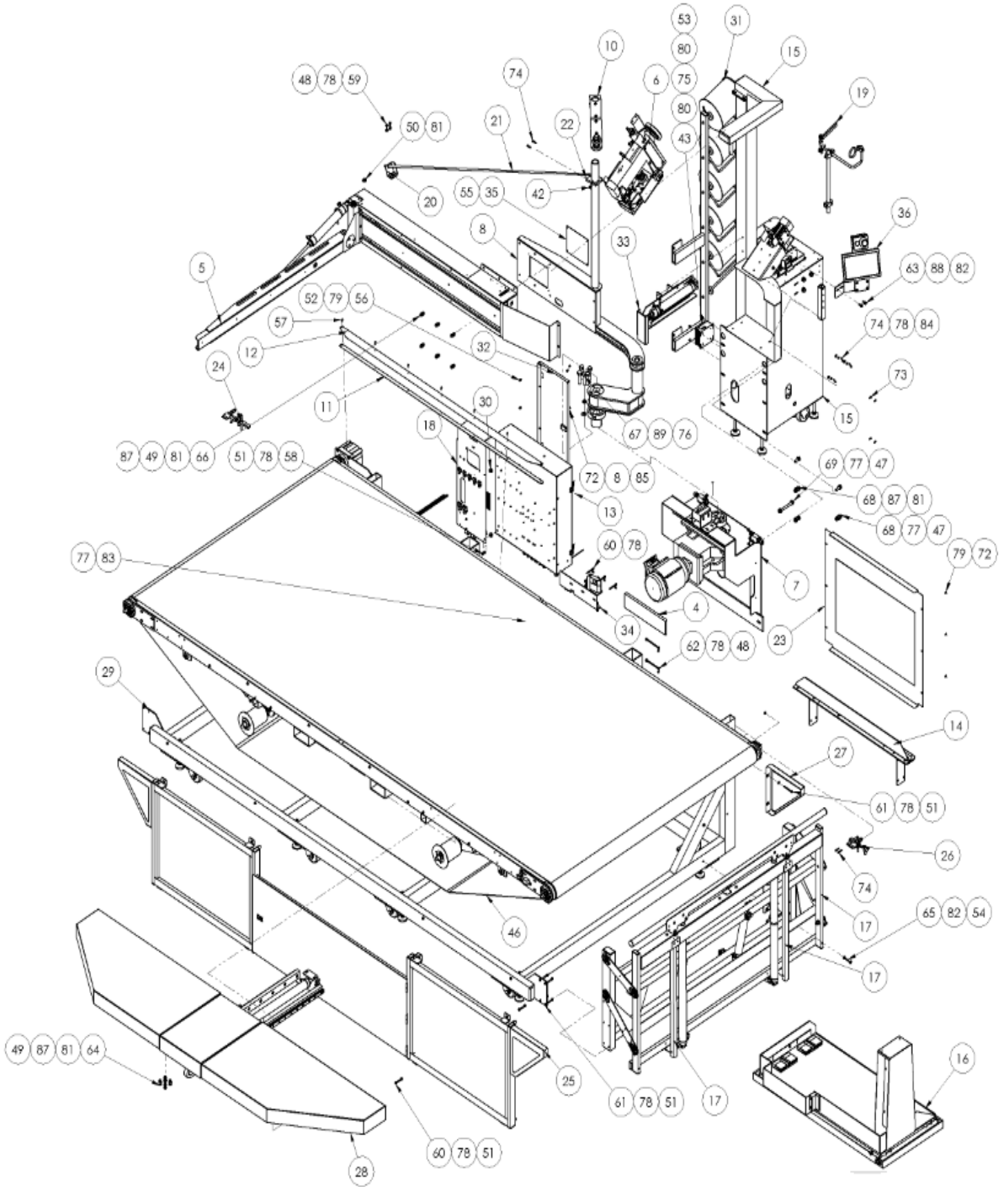

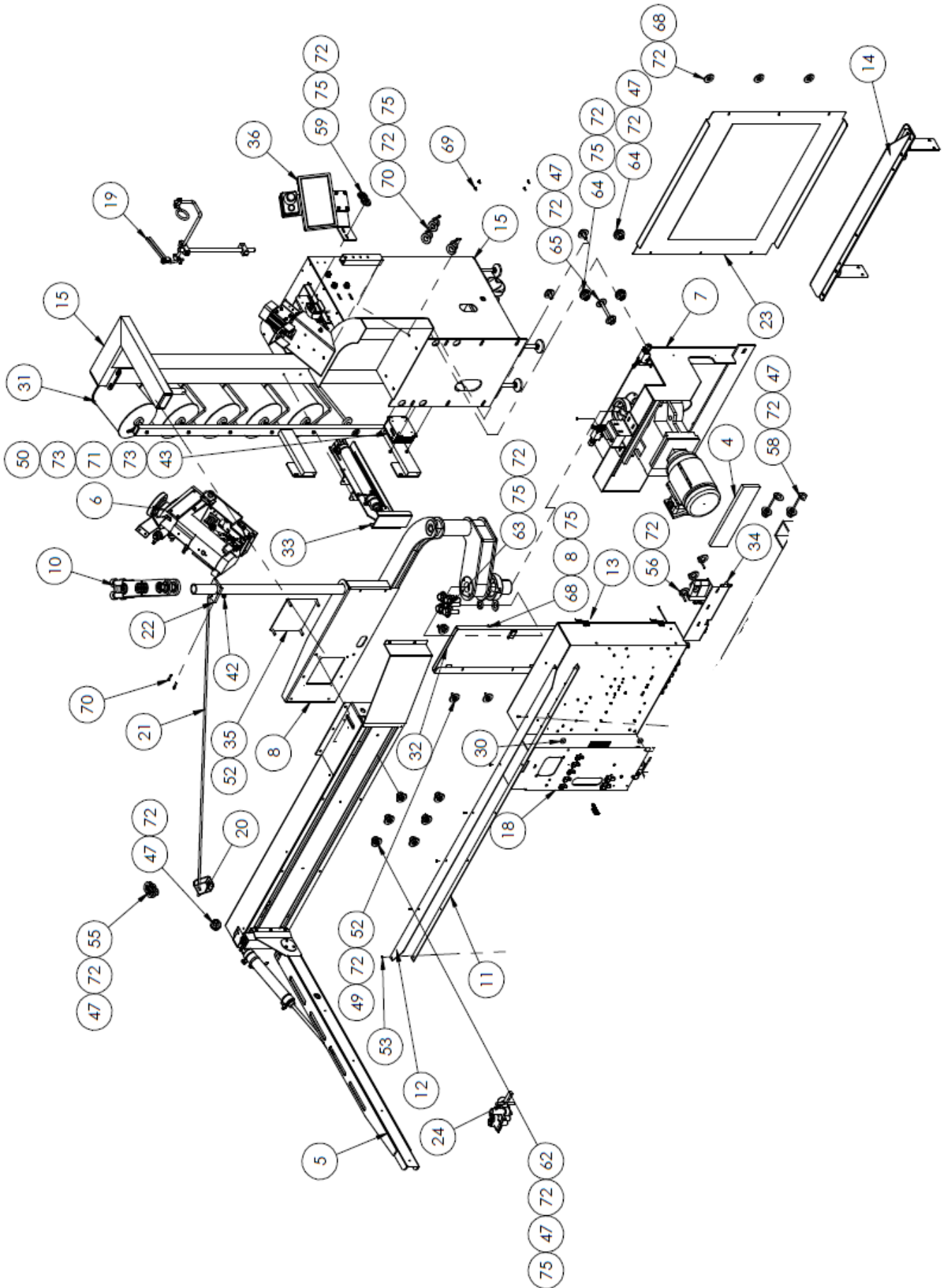

11315B parts list

ITEM NO.	QTY.	PART NUMBER	DESCRIPTION	ITEM NO.	QTY.	PART NUMBER	DESCRIPTION
1	1	1315-LAB1	LABELS, MAIN, BLK W/WHILETTERS	23	1	1315472	ASSY, COVER REAR
2	1	1315-LAB2	LABELS, CAUTION, YLW W/BLK LETTERS	24	1	1315479	AIR JET ASSEMBLY; RIGHT
3	1	1315-LAB3	LABELS, CONVEYOR	25	1	1315480	SUPPORT FRAME & DOOR ASSY
4	1	1315049	PAD, HIP	26	1	1315483	AIR JET ASSEMBLY; LEFT
5	1	1315050	ROTATE ARM ASSEMBLY	27	1	1315485	ASSY, GUARD TRI LEFT
6	1	1315100	SEW HEAD ASSEMBLY	28	1	1315498	PUSH PLATE ASSEMBLY
7	1	1315115	ARM GEARBOX ASSEMBLY	29	1	1315502	TABLE ASSEMBLY
8	1	1315160	WELDMENT, ROTATE ARM	30	4	1315564	SPACER, CONTROL BOX
9	1	1315166	FOOT GUARD PLATE	31	1	1315575	HOLDER, TAPE ROLL
10	1	1315195	ARM, SUPPORT, UPPER	32	1	1315590	DOOR, PNEU. PANEL
11	1	1315224	BELT GUARD SPACER	33	1	1315595	HEAD PUSHER ASSEMBLY
12	1	1315231	BELT GUARD	34	1	1315603	SENSOR BRKT. ASSEMBLY
13	1	1315245	CONTROL BOX, ELECTRICAL ASSY	35	1	1315642	COVER, ACCESS HOLE
14	1	1315250	GUIDE ROLLER ASSEMBLY	36	1	1315688	TOUCH SCREEN ASSEMBLY - 11315R
15	1	1315300	CONSOLE ASSEMBLY	37	1	1315B-WD	DIAGRAM,WIRING,SBUS 1315B
16	1	1315327	LIFT PLATFORM ASSEMBLY	38	1	1315B-WD1	DIAGRAM,WIRING, PWR AND SAFETY
17	1	1315400	ASSY, FLIPPER	39	1	4082004	PC POWER BLOCK BRACKET
18	1	1315430	PANEL, PNEUMATIC	40	1	9900748	SHIPPING BRACKET,
19	1	1315450	TAPE GUIDE ASSEMBLY	41	1	9900749	SHIPPING BRACKET,
20	1	1315460	BRACKET, ARM SUPPORT	42	1	CCCL6F	CLAMP COLLAR- 3/8
21	1	1315462	ROD, SUPPORT	43	1	EEJBC375CG	GATEWAY PC, W-PWR CBL, SERIAL
22	1	1315463	CLAMP, SUPPORT ROD	44	2	FF264-341	TERMBLK,WAGO,TOP,DUAL,GRY

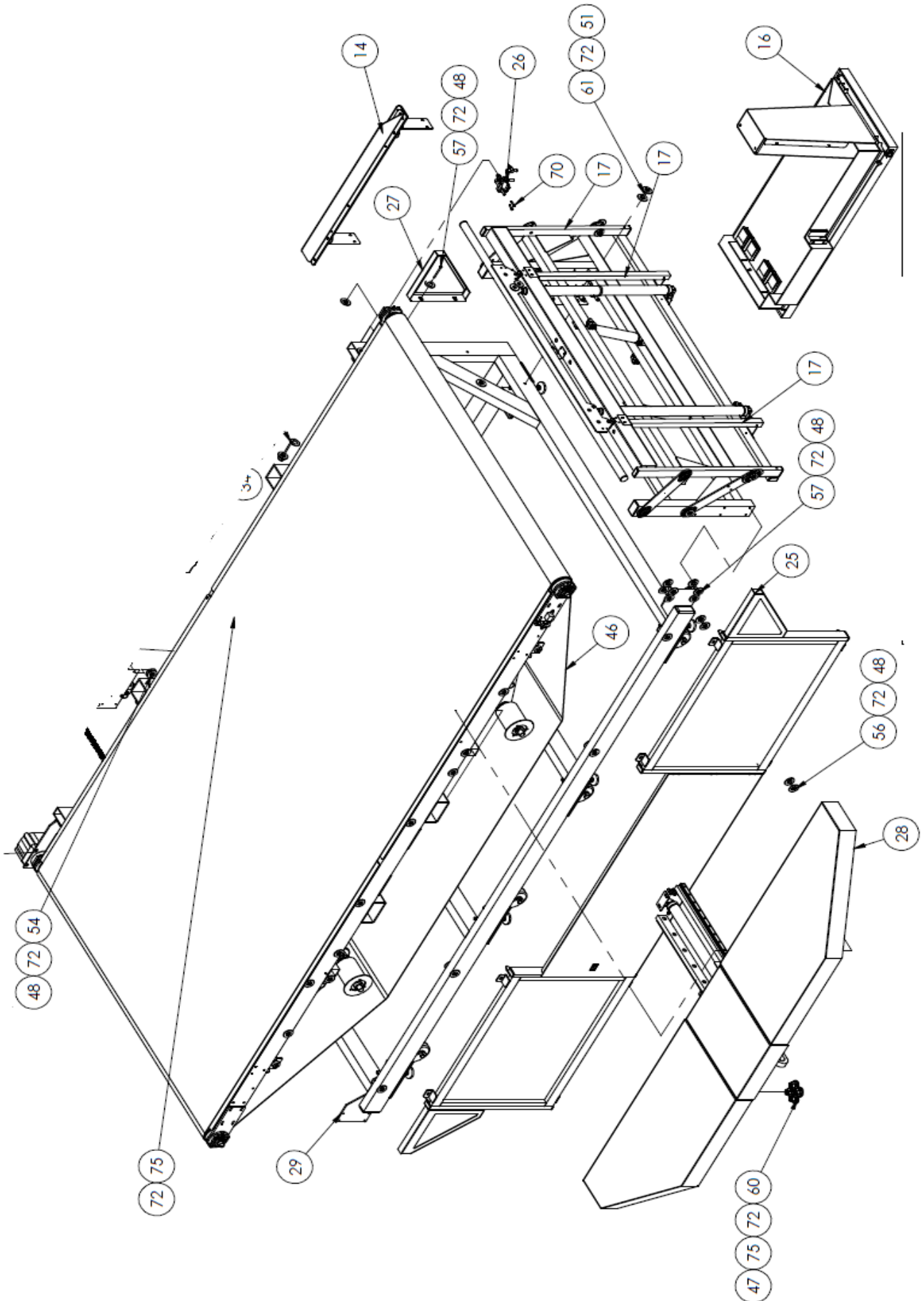

11315B parts list continued

ITEM NO.	QTY.	PART NUMBER	DESCRIPTION	ITEM NO.	QTY.	PART NUMBER	DESCRIPTION
45	1	FF264-371	TERMBLK,WAGO,TOP,END	67	5	SSHC34176	3/4-16 X 2-3/4 HEX HEAD
46	1	MMNCA2206	BELT, URETHANE,350" LONG	68	6	SSHC45096	1/2-13 X 1-1/2 HEX HEAD
47	6	NNH1/2-13	1/2-13 HEX NUT	69	2	SSHC45288	1/2-13 X 4-1/2 HEX HEAD
48	8	NNH1/4-20	1/4-20 HEX NUT	70	1	SSHC46080F	1/2-20 X 1-1/4 HEX HEAD FULL THD
49	16	NNH3/8-16	3/8-16 HEX NUT	71	2	SSHC98040	10-32X5/8 HEX HD
50	2	NNH3/8-24	3/8-24 HEX NUT	72	8	SSPP98024	#10-32 X 3/8 PAN HD PHIL
51	26	NNK1/4-20	KEP NUT, 1/4-20	73	4	SSPP98032	#10-32 X 1/2 PAN HD PHIL
52	2	NNK10-32	KEP NUT, 10-32	74	9	SSSC01064	1/4-20 X 1 SOC CAP
53	4	NNK10-32	KEP NUT, 10-32	75	4	SSSC98032	10-32X1/2, SOC CAP
54	2	NNK5/16-18	KEP NUT, 5/16-18	76	1	WWF5/8	WASHER, FLAT, 5/8
55	4	SSBC90024	#8-32 X 3/8 BUT HEAD	77	16	WWF5/16	WASHER, FLAT, 1/2
56	2	SSBC98040	#10-32 X 5/8 BUT HEAD	78	71	WWF5/16	WASHER FLAT, 1/4
57	7	SSBC98040	10-32 X 5/8 BUTTON CAP SC	79	10	WWF5/16	WASHER, FLAT #10
58	2	SSHC01064	1/4-20 X 1 HEX HEAD	80	10	WWF5/16	WASHER, FLAT, #10, SAE
59	2	SSHC01112	1/4-20 X 1-3/4 HEX HEAD	81	38	WWF5/16	WASHER, FLAT, 3/8
60	15	SSHC01160	1/4-20 X 2-1/2 HEX HEAD	82	8	WWF5/16	WASHER, FLAT, 5/16
61	11	SSHC01192	1/4-20 X 3 HEX HEAD	83	8	WWL1/2	1/2 LW
62	4	SSHC01320	1/4-20 X 5 HEX HEAD	84	11	WWL1/4	1/4 LW
63	4	SSHC10064	5/16-18 X 1" HEX HEAD	85	2	WWL10	#10 LW
64	8	SSHC10080	5/16-18 X 1-1/4 HEX HEAD	86	2	WWL10	WASHER,LOCK,#10
65	2	SSHC10176	5/16-18 X 2-3/4 HEX HEAD	87	20	WWL3/8	3/8 LW
66	8	SSHC25064	3/8-16 X 1 HEX HEAD	88	4	WWL5/16	5/16 LW
				89	1	WWL5/8	5/8 LW

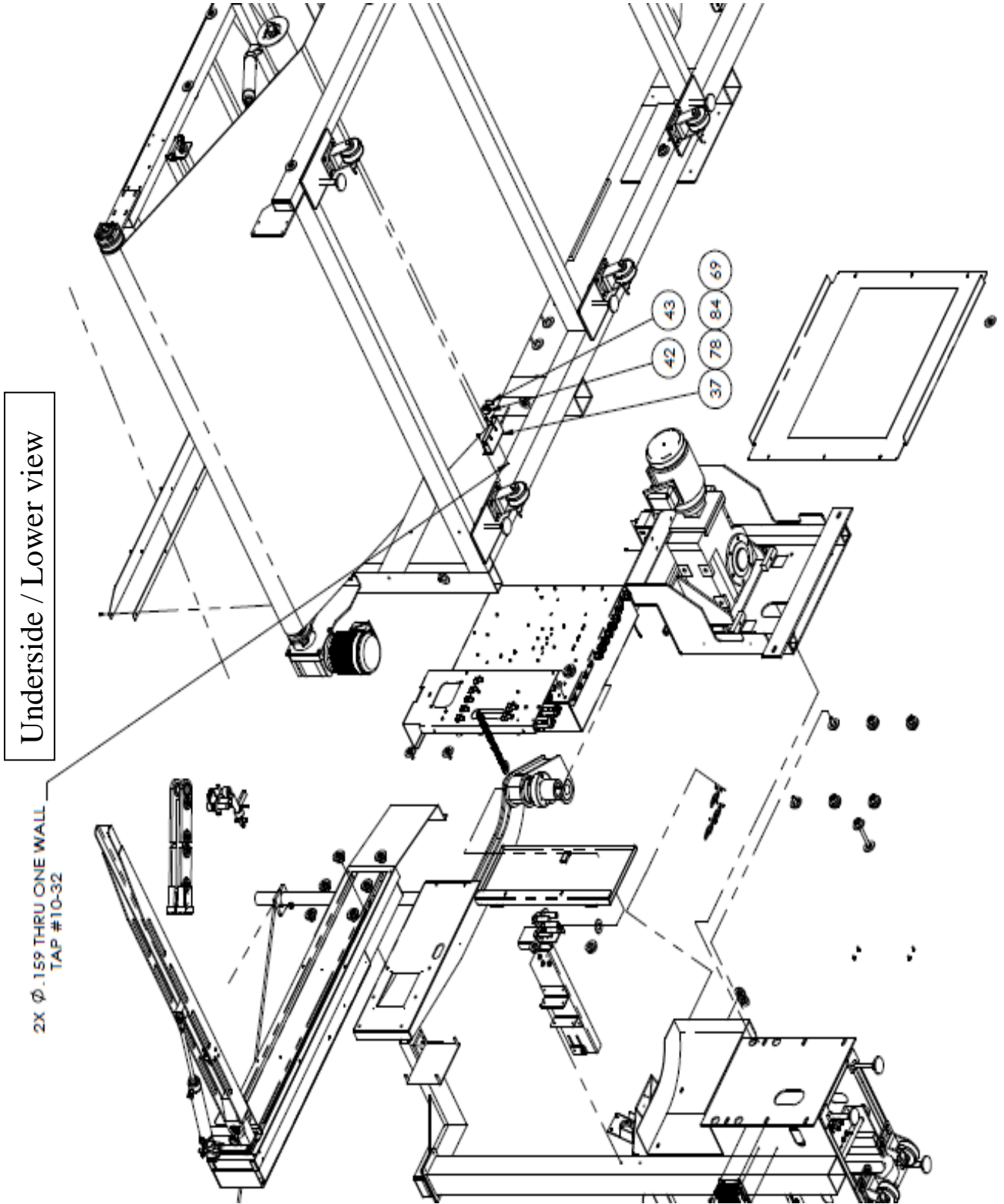

1315050 Rotate Arm Assembly

AAC Drawing Number 1315050 Rev 4

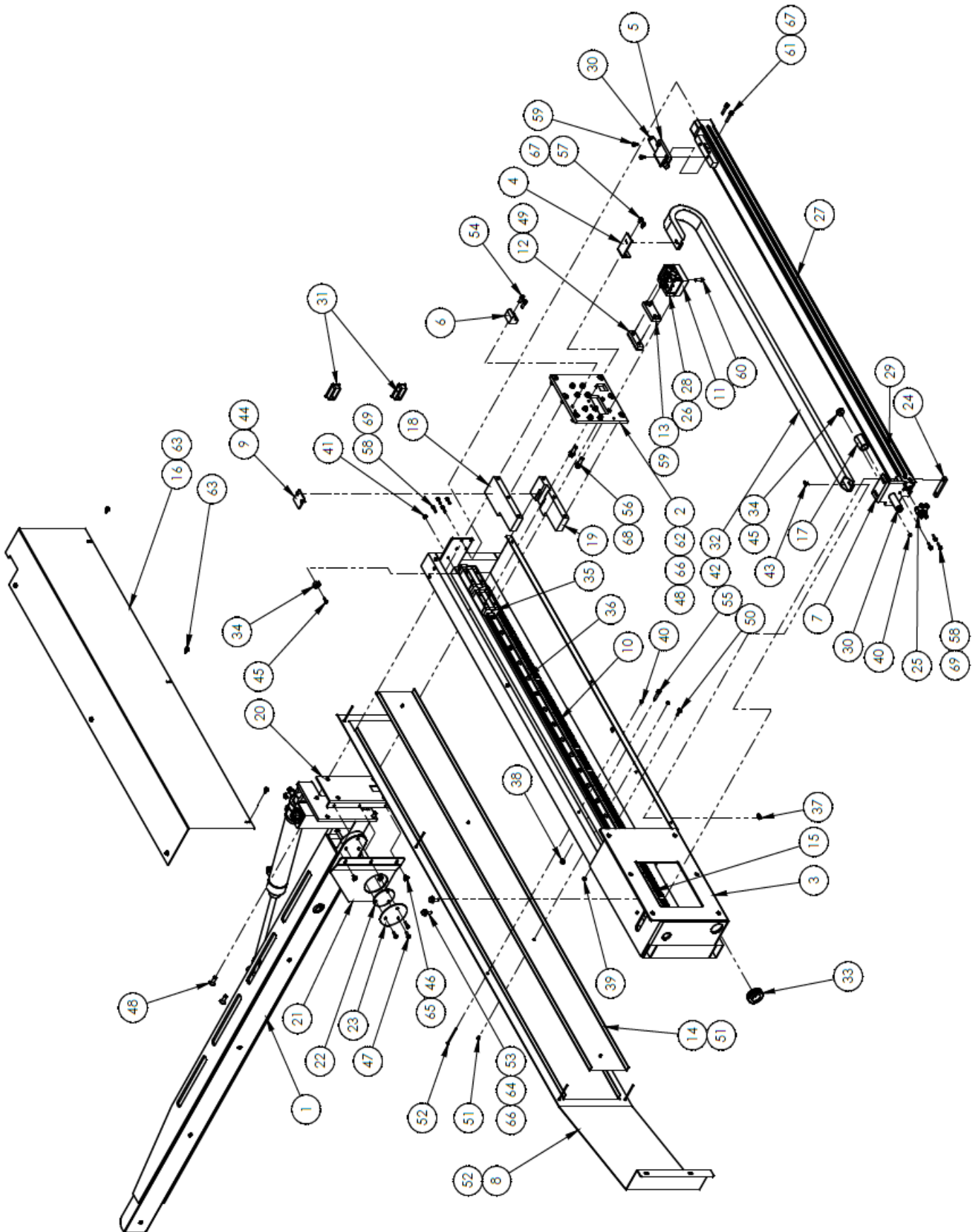

1315050 parts list

ITEM NO.	hardware shown/QTY.	PART NUMBER	DESCRIPTION	ITEM NO.	hardware shown/QTY.	PART NUMBER	DESCRIPTION
1	1	1315030	BACKSTOP ASSEMBLY	35	2	MMEGH25CA	LINEAR BEARING
2	1	1315033	CARRIER, BACK STOP	36	1	MMEGR25R1430C	RAIL,LINEAR ,AG SERIES
3	1	1315035	ARM, WELDMENT	37	2	NNE6-32	NUT,ELASTIC LOCK,6-32
4	1	1315036	MOUNT, CABLETRAK	38	10	NNK1/4-20	KEP NUT, 1/4-20
5	1	1315038	MOUNT, SHOCK	39	9	NNK10-32	KEP NUT, 10-32
6	1	1315039	BLOCK, STOP	40	13	NNK6-32	KEP NUT, 6-32
7	1	1315040	MOUNT, CYLINDER	41	1	NNK8-32	KEP NUT, 8-32
8	1	1315041	COVER, ARM LONG	42	2	SSBC80016	#6-32 X 1/4 BUT HEAD
9	1	1315042	COVER, CABLE	43	2	SSBC80024	#6-32 X 3/8 BUT HEAD
10	1	1315184	RACK, LONG GEAR	44	2	SSBC90024	#8-32 X 3/8 BUT HEAD
11	1	1315186	BLOCK, MOUNT CYL	45	2	SSBC90032	#8-32 X 1/2 BUT HEAD
12	1	1315187	RACK, LOCKING GEAR	46	3	SSBC98024	10-32 X 3/8 BUTON CAP SC
13	1	1315188	MOUNT, GEAR RACK SMALL	47	3	SSBC98040	10-32 X 5/8 BUTON CAP SC
14	1	1315197	COVER, ARM CENTER	48	10	SSFC10056	5/16-18 X 7/8 FLAT ALLEN
15	1	1315199	RACK, SHORT GEAR	49	2	SSFC98032	#10-32 X 1/2 FLAT ALLEN
16	1	1315432	COVER, ARM, FRONT	50	9	SSFC98048	#10-32 X 3/4 FLAT ALLEN
17	1	1315445	COLLAR, STOP	51	4	SSF880016	#6-32 X 1/4 FLAT SLOT
18	1	1315516	SPACER, PIVOT PLATE	52	8	SSF880144	#6-32 X 2-1/4, FLAT SLOT
19	1	1315520	SPACER, PIVOT PLATE	53	2	SSHC01056	1/4-20 X 7/8 HEX HEAD
20	1	1315722	CORNER FILL BRKT	54	2	SSSC01040	1/4-20 X 5/8" SOC. CAP SC
21	1	1315723	CORNER FILL PLATE	55	10	SSSC01064	1/4-20 X 1 SOC CAP
22	1	1315724	BACKSTOP PIVOT SPACER	56	2	SSSC10064	5/16-18 X 1 SOCKET CAP
23	1	1315725	BACKSTOP PIVOT CAP	57	2	SSSC98024	10-32 X 3/8 SOC CAP
24	1	96-5606	PLATE, NUT 2.0 CTC 1/4	58	7	SSSCM4X16	M4-0.7 X 16 SOC CAP
25	2	AA198RA408U	FLOW CONTROL,RC 1/8uX1/4	59	6	SSSCM5X10	M5-0.8 X 10 SOC CAP
26	2	AA198RA510	FL CONT,5/32X10-32	60	4	SSSCM5X20	M5-0.8 X 20 SOC CAP
27	1	AACDGP251220	CYLINDER,AIR,RODLESS	61	2	SSSCM5X30	M5-0.8 X 30 SOC CAP
28	1	AACMGPM1610	CYLINDER, AIR,DUAL ROD	62	8	SSSCM6X20	M6-1.0 X 20 SOC CAP
29	1	AAESME8KLED24M	SENSOR FOR FESTO DNCB CYL	63	6	SSZ93032	SCREW, SHT.METAL 10 ZIP
30	2	AAOEM.5BSA	SHOCK, 3/4-18 X 3.5	64	2	WWF51/4	WASHER FLAT, 1/4
31	2	MM132-1496	PLUG 1 X 2	65	3	WWF510	WASHER, FLAT, #10, SAE
32	1	MM180302848	DUCT,WIRE MIC,ROTRAK	66	10	WWL1/4	1/4 LW
33	1	MM2772	GROMMET,1 ID X 3/16 GR	67	4	WWL10	#10 LW
34	2	MM9405K14	BUMPER,RECESSED,ELASTOMER	68	2	WWL5/16	5/16 LW
35	2	MMEGH25CA	LINEAR BEARING	69	7	WWL8	#8 LW

1315030 Backstop Assembly

AAC Drawing Number 1315030 Rev 2

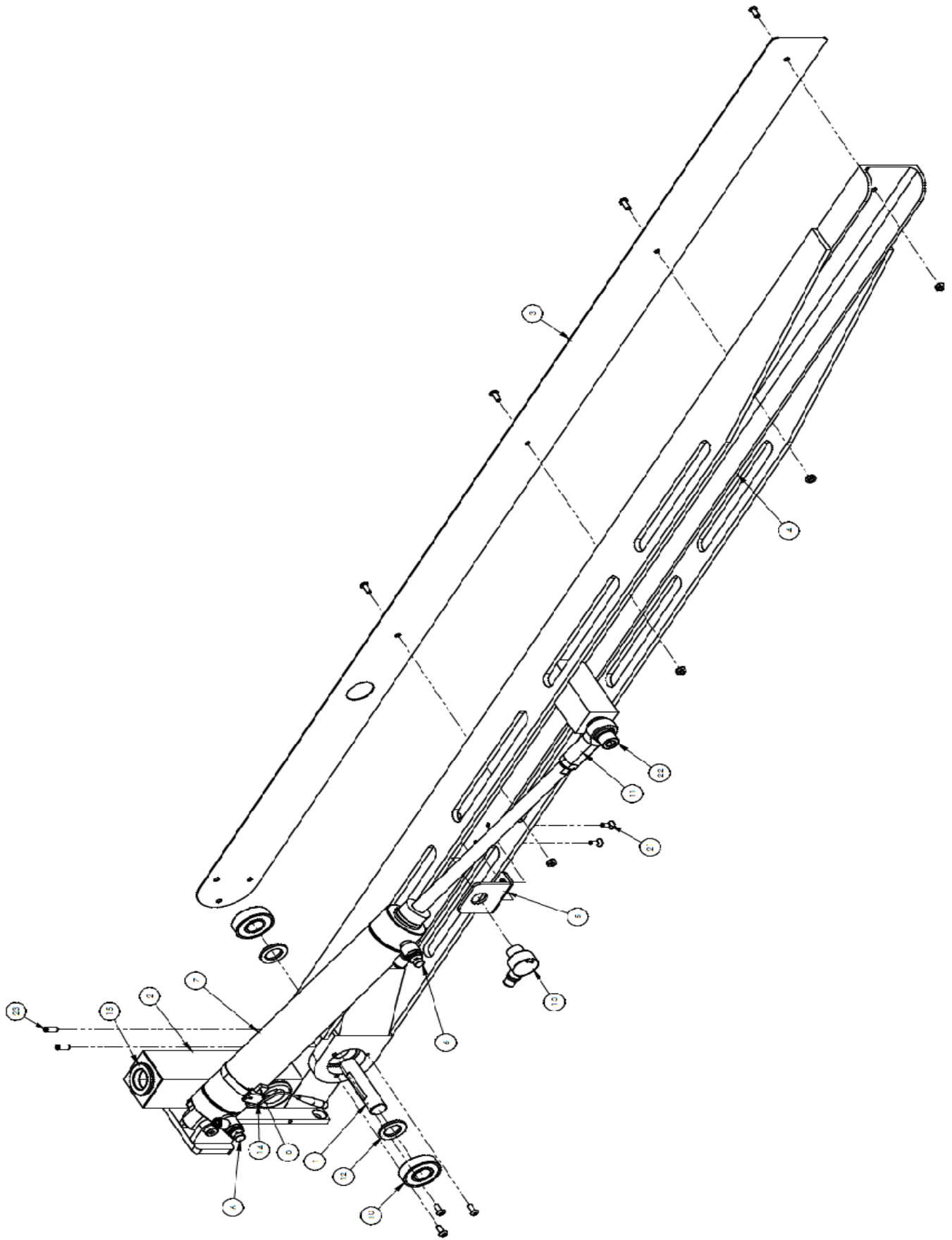

Enlarged view
1315030

ITEM NO.	QTY	PART NUMBER	DESCRIPTION
1	1	1315023	SHAFT, BACK STOP PIVOT
2	1	1315024	WELDMENT, PIVOT BLOCK
3	1	1315029	PLATE, ARM COVER
4	1	1315059	WELDMENT, BACKSTOP
5	1	1315062	BRACKET, BACKSTOP SENSOR
6	2	AA2201-07	FLOW CONTROL, 1/4TX1/4NPT
7	1	AACCM3110DXP	CYLINDER, AIR, D.A. W/MAGNET
8	1	AAEHSKG	SWITCH, HALL EFFECT BIMBA
9	1	AAFD35875-14	BAND, CYLINDER, HSKG HAL
10	2	BB2281288	BEARING, BALL, .75 ID
11	1	BBAW-8Z	BEARING, ROD END, FEMALE
12	2	BBTT5906K518	BEARING, THRUST, .75ID X 1.25
13	1	FFT18FF100Q	EYE, FIXED FIELD, 4IN
14	1	MM9307K74	GROMMET, 3/4ID, 1.38OD, .13GV
15	1	MM9602K14	GROMMET, RUBBER, 1" ID
16	1	NNE5/16-18	NUT, ELASTIC LOCK, 5/16-18
17	1	NINJ1/2-20	1/2-20 HEX JAM NUT
18	4	NINK10-32	KEP NUT, 10-32
19	1	SSAS024096	3/8 X 1-1/2 X 5/16-18 SHLD, BOL
20	7	SSBC98032	#10-32 X 1/2 BUT HEAD
21	2	SSFC98032	#10-32 X 1/2 FLAT ALLEN
22	1	SSSC46096	SOCKET CAP, 1/2-20 X 1 1/2
23	2	SSSS01040	1/4-20 X 5/8 KNURL PT
24	1	WWL1/2	1/2 LW

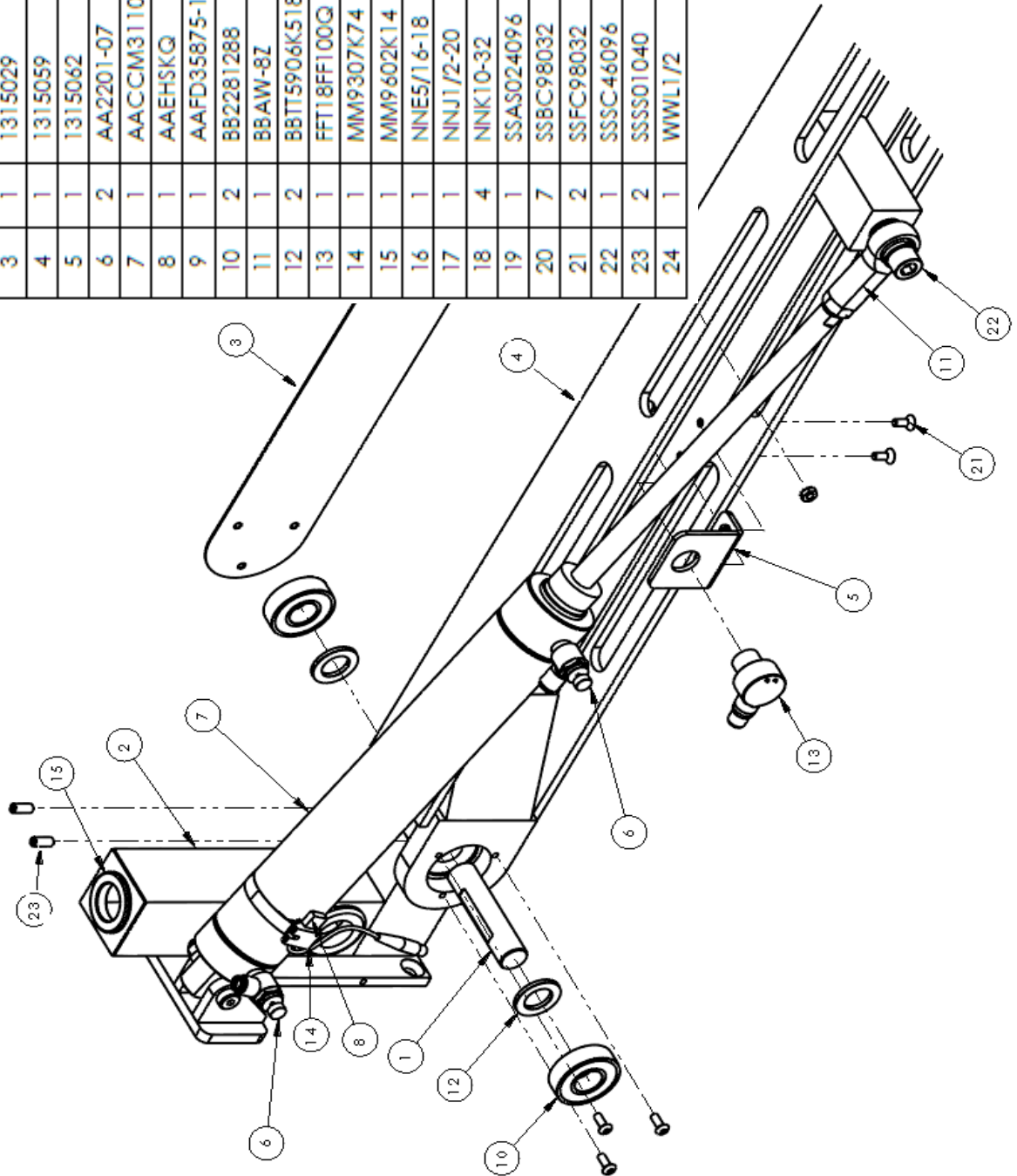

1315100 Sew Head Assembly

AAC Drawing Number 1315100 Rev 9

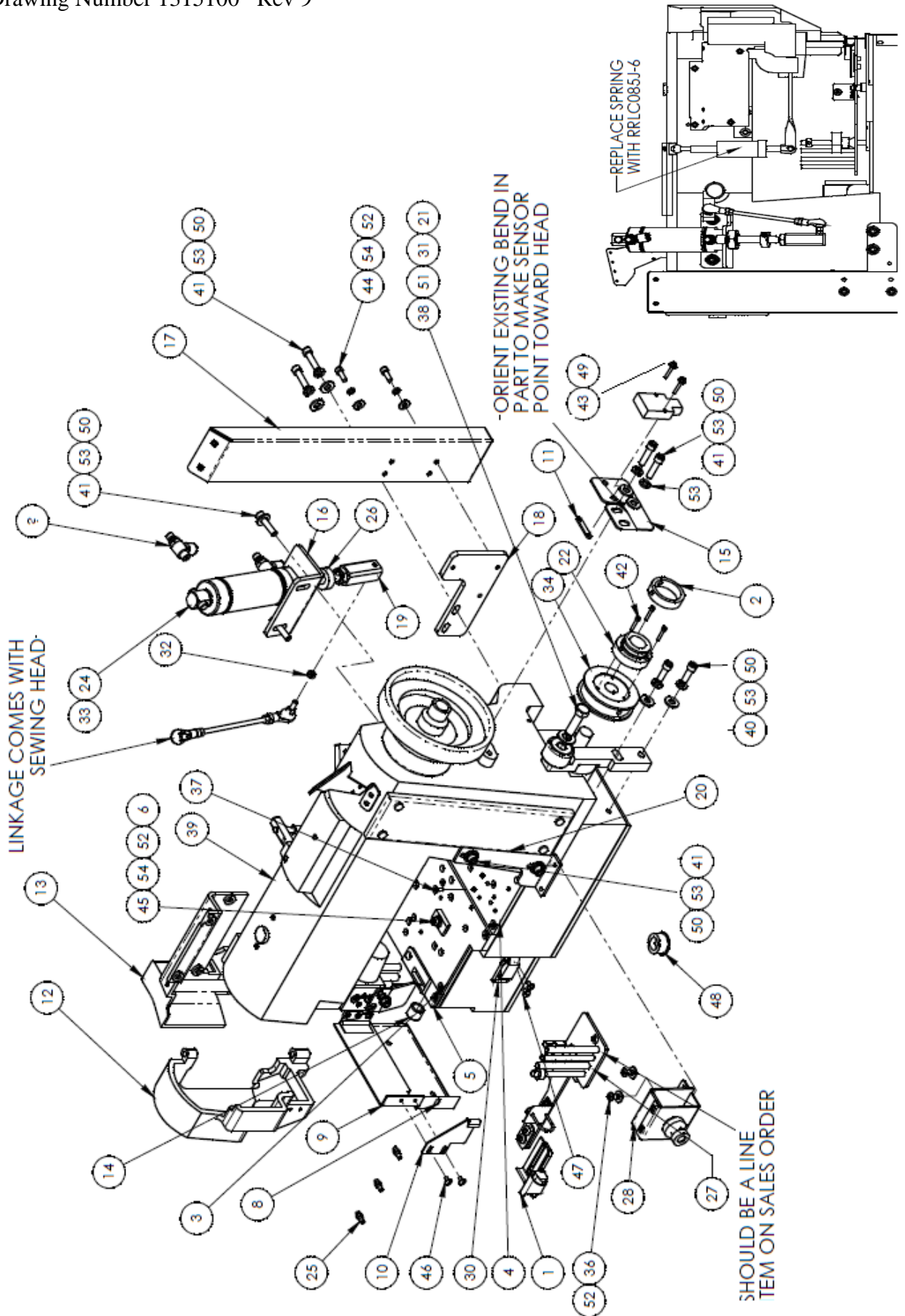

1315100 parts list

NO	QTY	PART #	DESCRIPTION	NO	QTY	PART #	DESCRIPTION
1	1	221-TCBINDER	BINDER BLOCK, SPEC. BYCUST.	28	1	F221-T008	TENSIONER BOX ASSY,2" MAX
2	1	311-129	SLEEVE, TAPE MOUNT ADJUST	29	1	FSM312LVQ	EYE,ELECTRIC,10-30VDC
3	AR	1345-002	PLATE, BED, LEFT MOD	30	AR	MM1590A13	LATCH, DRAW PULL
4	AR	1345-002A	PLATE, BED, RIGHT,MOD	31	AR	MMCYR114S	FOLLOWER, CAM
5	AR	1345-003	MOD. THROAT PLATE STD.	32	1	NNHM5X0.8	NUT,HEX,M5-0.8
6	1	1345-004	BLOCK, STOP FOR BINDER	33	1	NNJ7/16-20	NUT,JAM,7/16-20
7	1	1345-005	SEWING HEAD,MOD	34	1	PP20LB050M2	PULLEY,GEAR,3/8P,.63B,20T
8	AR	1345-011	PLATE, END COVER	35	1	RRLC085J-6	SPRING, COMP. .720OD 2.0
9	AR	1345-012	THREAD ACCESS DOOR ASSY	36	2	SSBC98016	10-32 X 1/4 BUTTON CAP SC
10	AR	1345-014	LATCH, SNAP HOOK	37	1	SSFC90024	8-32 X 3/8 FL ALN CAP
11	1	1975-412A	PLATE,NUT,4-40.,95CTC	38	AR	SSHC25080	3/8-16 X 1-1/4 HHCS
12	AR	160505B	COVER,END, MOD.	39	1	SSIN-300UX6	SEWING HEAD, 300UX6
13	AR	160506B	BACK COVER, UX5 MOD.	40	2	SSCC01048	1/4-20 X 3/4" SOC CAP SC
14	AR	268071	BEARING,NEEDLE LFT RCK SHIFT 300U	41	8	SSCC01064	1/4-20 X 1 SOC CAP
15	1	1315246	BRKT, EYE	42	3	SSCC70040	4-40 X 5/8, SCREW, SOCKET CAP
16	1	1315507	BRACKET, CYLINDER	43	2	SSCC70048	4-40 X 3/4 SOCKET CAP
17	1	1315574	GUIDE, THREAD	44	2	SSCC98032	10-32X1/2, SOC CAP
18	1	1315585	BRKT, MOUNT, THREAD GUIDE	45	1	SSCC98040	10-32 X 5/8 SOC CAP
19	1	1317307	CYLINDER END, FOOTLIFT	46	AR	SSTS80016	# 6-40 X 3/16 TRUSS HD
20	1	1338115	BRKT, TENSION FOLDER	47	2	SSTS85016	# 6-40 X 1/4 TRUSS HEAD
21	AR	13453066	MOUNT,BELT TENSION	48	1	TA2351004-R0	RUBBER PLUG
22	1	13453646	TAPE MOUNT, PULLEY	49	2	WWF4	WASHER, FLAT, #4
23	2	AA198RA508	FLOW CONTROL,5/32 X 1/8"	50	12	WWFS1/4	WASHER,FLAT,SAE,1/4
24	1	AAC5DP-2	AIR CYLINDER, SMC	51	AR	WWFS3/8	WASHER,FLAT,SAE,3/8
25	3	AAF11752-3	BRASS BARB FOR AIRLINE.	52	5	WWFS10	WASHER, FLAT, #10, SAE
26	1	CCSCL7F	CLAMP COLLAR- 7/16	53	12	WWL1/4	WASHER,LOCK, 1/4
27	AR	F221-T006	ASSY,SWING OUT,TAPE EDGE	54	3	WWL10	WASHER,LOCK,#10

1315115 Arm Gearbox Assembly

AAC Drawing Number 1315115 Rev 5

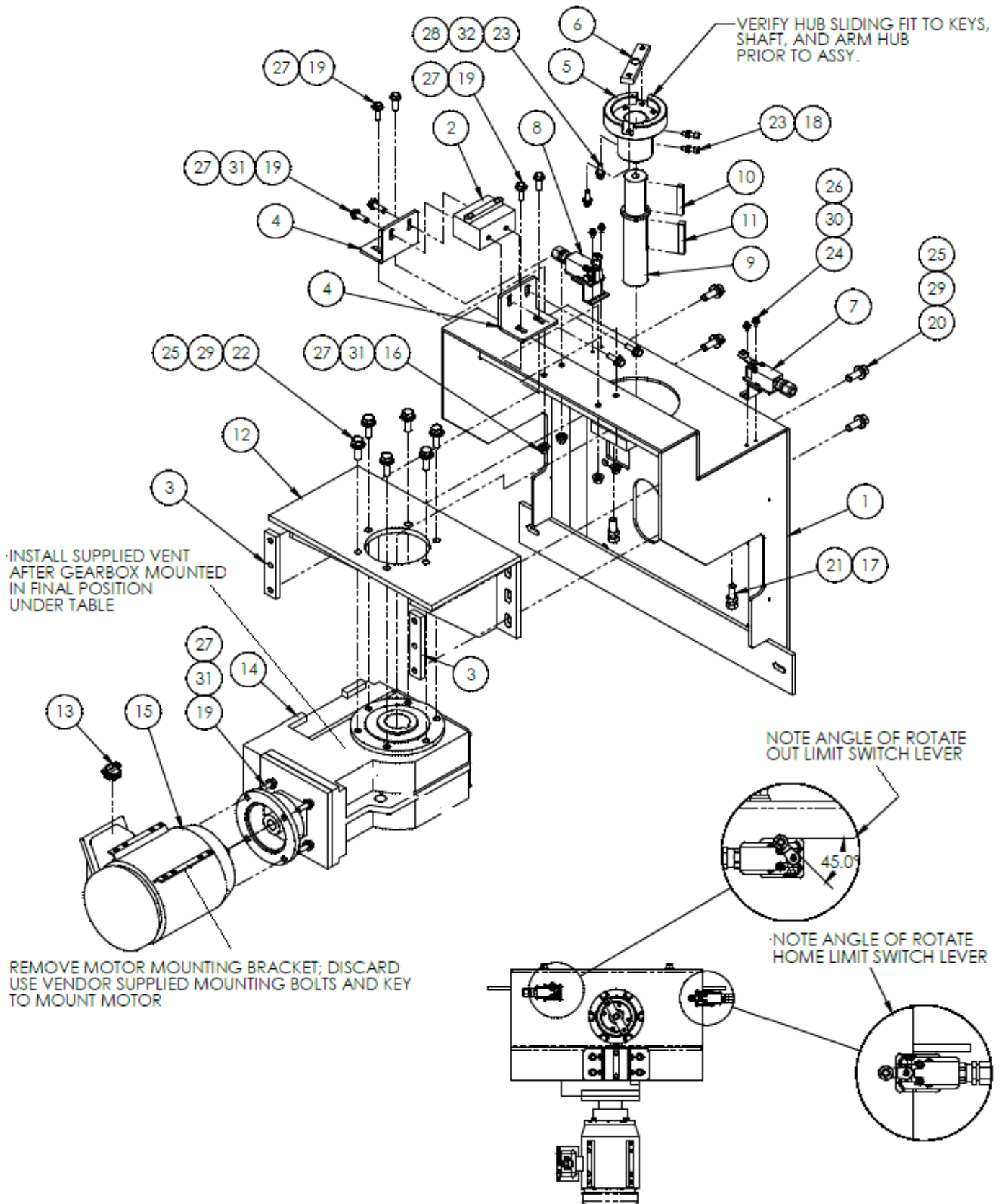

1315115 parts list

ITEM NO.	QTY	PART NUMBER	DESCRIPTION
1	1	1315105	MOUNT, ROTATE ARM MOTOR
2	1	1315111	MOUNT, SLIDE MOTOR
3	2	1315112	PLATE, NUT 1/2-13 2.5 CTC
4	2	1315113	BRACKET, MOTOR MOUNT
5	1	1315283	HUB, ARM MOTOR
6	1	1315372	KEY, ROTATE ARM
7	1	1315435	LIMIT SWITCH ASSEMBLY
8	1	1315435	LIMIT SWITCH ASSEMBLY
9	1	1315717	GEARBOX SHAFT
10	1	1315718	KEY, 3/8X3/8X2.86L
11	1	1315719	KEY, 1/2X1/2X2.94L
12	1	1315720	MOUNT, ARM MOTOR
13	1	K-235A	CONNECTOR,ROMEX,3/4"
14	1	MMBF883CN140TC	REDUCER, GEAR, 193.24:1 RATIO
15	1	MMY368	MOTOR, INVERT DUTY 2 HP
16	4	NNH3/8-16	NUT,HEX,3/8-16
17	2	NNJ1/2-20	NUT, JAM, 1/2-20
18	2	NNJ5/16-24	NUT,JAM,5/16-24
19	12	SSHC25080	3/8-16X1-1/4 HHCS
20	4	SSHC45096	1/2-13X1-1/2 HEX CAP
21	2	SSHC46112F	1/2-20X1-3/4 FULL THD HC
22	6	SSHCM12X40	SCREW,HEX CAP M12-1.75X40
23	4	SSSC20064	5/16-24X1, SOC SAP
24	4	SSSC98032	10-32X1/2, SOC CAP
25	10	WWFS1/2	WASHER,FLAT,1/2, SAE
26	4	WWFS10	WASHER, FLAT, #10, SAE
27	16	WWFS3/8	WASHER,FLAT,SAE,3/8
28	2	WWFS5/16	WASHER,FLAT,SAE,5/16
29	10	WWL1/2	1/2 LOCK WASHER
30	4	WWL10	WASHER,LOCK,#10
31	12	WWL3/8	WASHER,LOCK, 3/8
32	2	WWL5/16	WASHER,LOCK, 5/16

NOTE ANGLE OF ROTATE
OUT LIMIT SWITCH LEVER

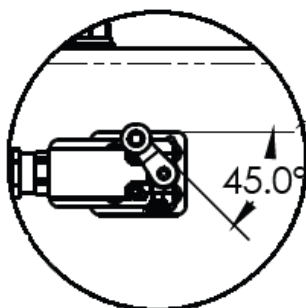

NOTE ANGLE OF ROTATE
HOME LIMIT SWITCH LEVER

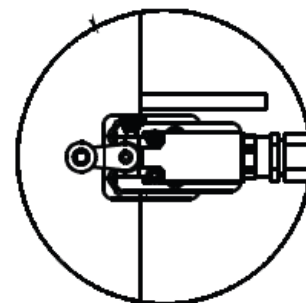

1315435 Limit Switch Assembly

AAC Drawing Number 1315435 Rev 4

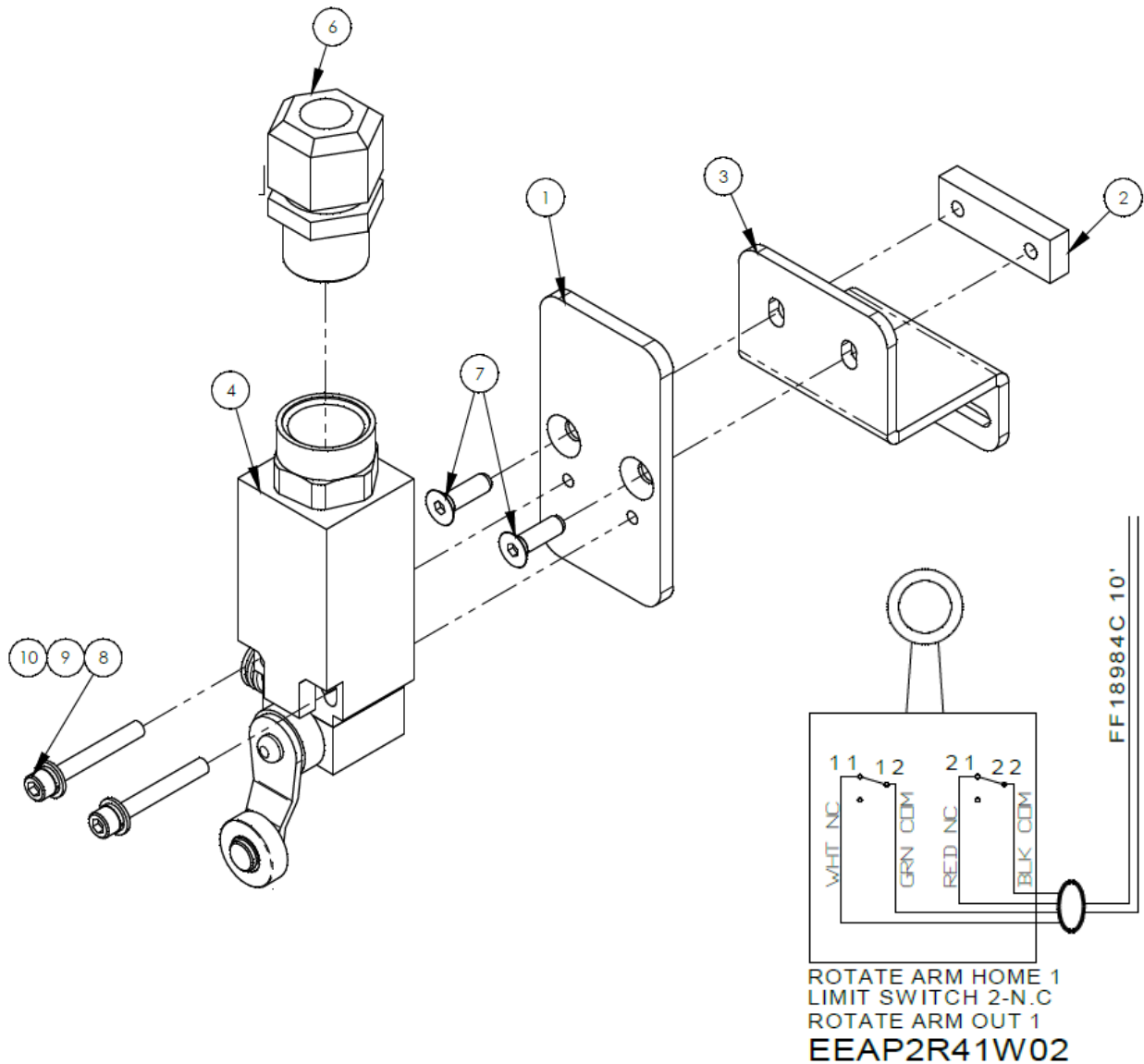

NO	QTY	PART #	DESCRIPTION
1	1	1315157	PLATE, LIMIT SENSOR
2	1	1315428	PLATE,NUT 10-32 25MM CTC
3	1	1315429	MOUNT, SENSOR HORZ.
4	1	EEAP2R41W02	SWITCH, SAFETY, LIMIT,
5	*10'	FF18984C	CABLE,4 COND,18 AWG,300V
6	1	FFM4518	STRAIN RELIEF,LIQ TIGHT
7	2	SSFC98040	#10-32 X 5/8 FLAT ALLEN
8	2	SSSC90080	#8-32 X 1-1/4 SOC CAP SC
9	2	WWF8	WASHER, FLAT, #8
10	2	WWL8	WASHER,LOCK,#8

1315245 Control Box. Electrical Assembly

AAC Drawing Number 1315245 Rev 4

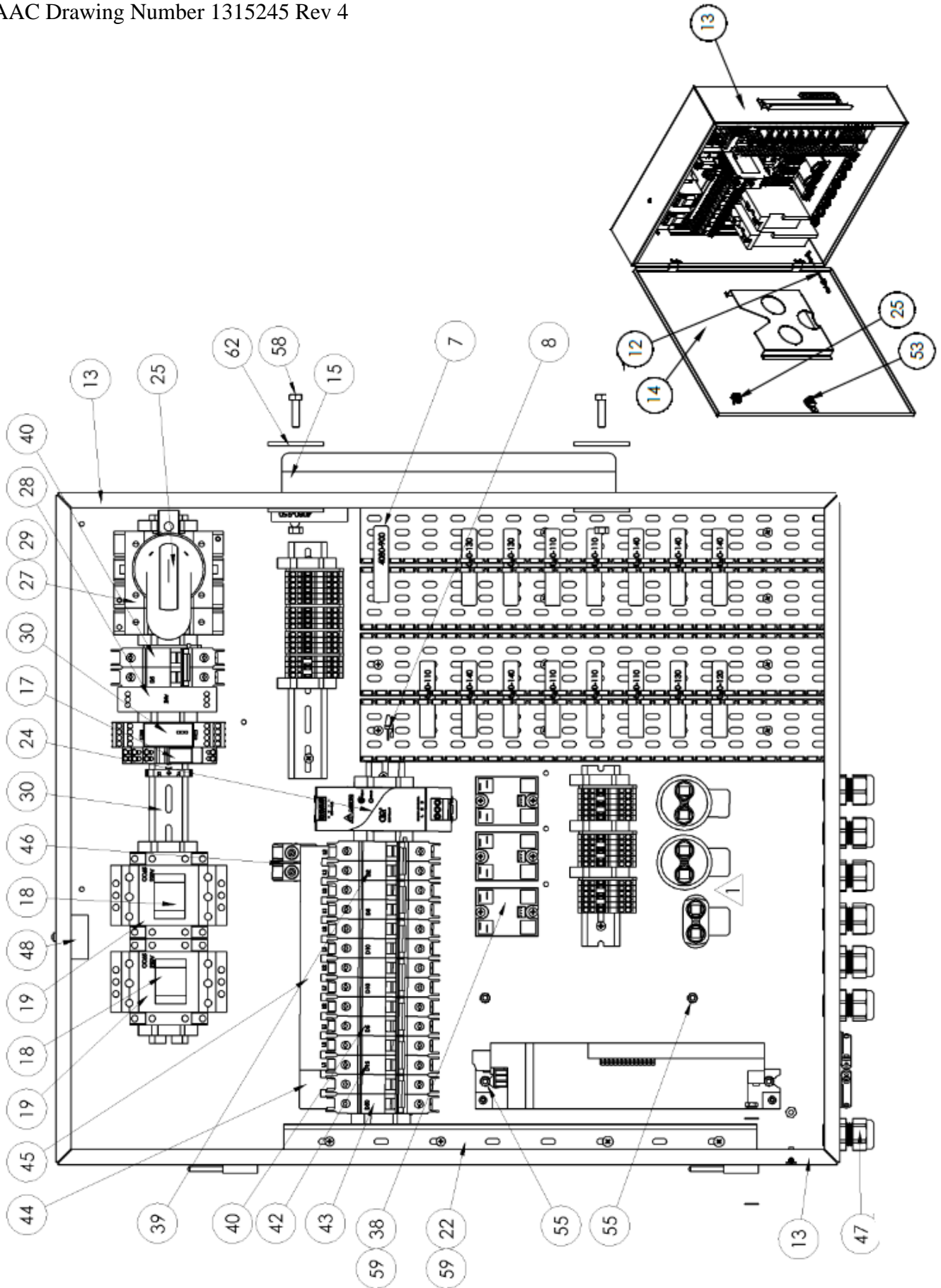

1315245 parts

ITEM	QTY	PART NUMBER	DESCRIPTION	ITEM	QTY	PART NUMBER	DESCRIPTION
1	1	1315B-WD1	DIAGRAM,WIRING, PWR AND SAFETY	33	8	FF280-402	JUMPER,WAGO,TOP,SNGL
2	1	1315B-WD	DIAGRAM,WIRING,SBUS 1315B	34	33	FF280-901	TERMBLK,WAGO,TOP,SNGL,GRY
3	6	4080-110	MODULE,QUAD INPUT	35	3	FF280-907	TERMBLK,WAGO,TOP,SNGL,GRN
4	1	4080-120	MODULE,SBUS, DUAL OPTO-ISO, INPT	36	9	FF8463	NUT,LOCK, 1/2NPT,NYLON,BLK
5	3	4080-130	MODULE,QUAD OPTO-ISO	37	20 FT	FF19511	CABLE, 3 COND, 14 AWG, SJTOW
6	5	4080-140	MODULE,QUAD OUTPUT	38	3	FF84140610M1	RELAY,SSR,600VAC,40A
7	1	4080-900	SBUS MODULE, USB GATEWAY, INTERFACE	39	1	FFFAZD22NA	BREAKER,2P, 2A,UL489,240VT-MAG
8	1	4080-940	MODULE,TERMINATOR	40	3	FFFAZD52NA	BREAKER,2P,5A,UL489,
9	1	4080-950	MODULE,POWER	41	2	FFFAZD102NA	BREAKER,2P,10A,UL489,
10	*1	4080-4250-24	CABLE,SBUS,POWER,PS - PWR MOD,24"	42	1	FFFAZD152NA	BREAKER,2P,15A,UL489,240VT-MAG
11	*3	4080-4260-22	SBUS, 4 COND, 22IN LONG	43	1	FFFAZD302NA	BREAKER,2P,30,UL489,240VT-MAG
12	1	1315083	CONTROL BOX DOOR GROUND	44	1	FFM9XUP206	BREAKER,ACC,UL489,COMB,18MM,2P6
13	1	1315243	BOX, CONTROL, ELECTRICAL	45	1	FFM9XUP212	BREAKER,ACC,UL489,COMB,18MM,2P12
14	1	1315562	DOOR, CONTROL BOX	46	2	FFM9XUPC04	BREAKER,ACC,UL489,COMB,18MM,TOP
15	1	1315588	CATCH, PNEU. PANEL	47	7	FFM3200	STRAIN RELIEF, 1/2NPT, .26-.55, BLK
16	3	13459004	MOUNTING BRACKET, CAPACIT	48	1	FFRAV781BW	MODULE, TVS, 240 VAC
17	1	EE788304	RELAY,24V,SPDT,WAGO	49	2	K-235A	CONNECTOR,ROMEX,3/4"
18	2	EEAP9	COVER,SAFETY, CONTACTOR,65A,	50	2	MM1155LA	HINGE, MALE, LEFT
19	2	EECGC85A220	CONTACTOR,65A,220VAC	51	1	MM510155B1M1	DRIVE, VFD ,I510,75HP, 240V, 1PH, NET,
20	13	EECLIPFIX	ANCHOR,DIN RAIL	52	1	MM510215B1M1	DRIVE, VFD, I510, 2HP, MODBUS
21	7	EEDC2X2	COVER,WIRE DUCT	53	1	MMELH-1	LATCH, 1/4 TURN, SLOTTED
22	1	EEDFIX1	DUCT,WIRE,1X1	54	2	NNE8-32	NUT,ELASTIC LOCK, 8-32
23	4	EEDFX2	DUCT,WIRE,2X2, MOD	55	2	NNK1/4-20	KEP NUT, 1/4-20
24	1	EEDRP24V100W	POWER SUP, SW, 24V 3.8A	56	4	NNK8-32	NUT,KEP,8-32
25	1	EEHR65	DISCONNECT HANDLE,PISTOL	57	4	NNK10-32	KEP NUT, 10-32
26	1	EELG5925-24	RELAY,SAFETY, 2 CHAN, 24V	58	4	SSBC98032	10-32 X 1/2 BUTTON CAP SC
27	1	EEM30U3M	DISCONNECT ASSY, 3PH, 30A	59	2	SSHC01064	1/4-20 X 1 HEX HEAD
28	1	EEMDR2024	POWER SUP,SWITCHER,24V,1.0A,DIN	60	38	SSPP90024	8-32X3/8 PAN PHILPS
29	1	EESPA210-5.10	DISCONNECT SHAFT,MOD	61	7	SSPP98024	10-32 X 3/8 PAN HD PHILIP
30	23	EETS35X7.5A	DIN RAIL-AMERICAN	62	8	WWF10	WASHER, FLAT, #10, COM
31	1	FF209-120	DIN MOUNTING FOOT,SHORT	63	4	WWFS1/4	WASHER FLAT, 1/4
32	8	FF280-308	TERMBLK ENDPLATE,WAGO,280				

1315300 Console Assembly

AAC Drawing Number 1315300 Rev 3

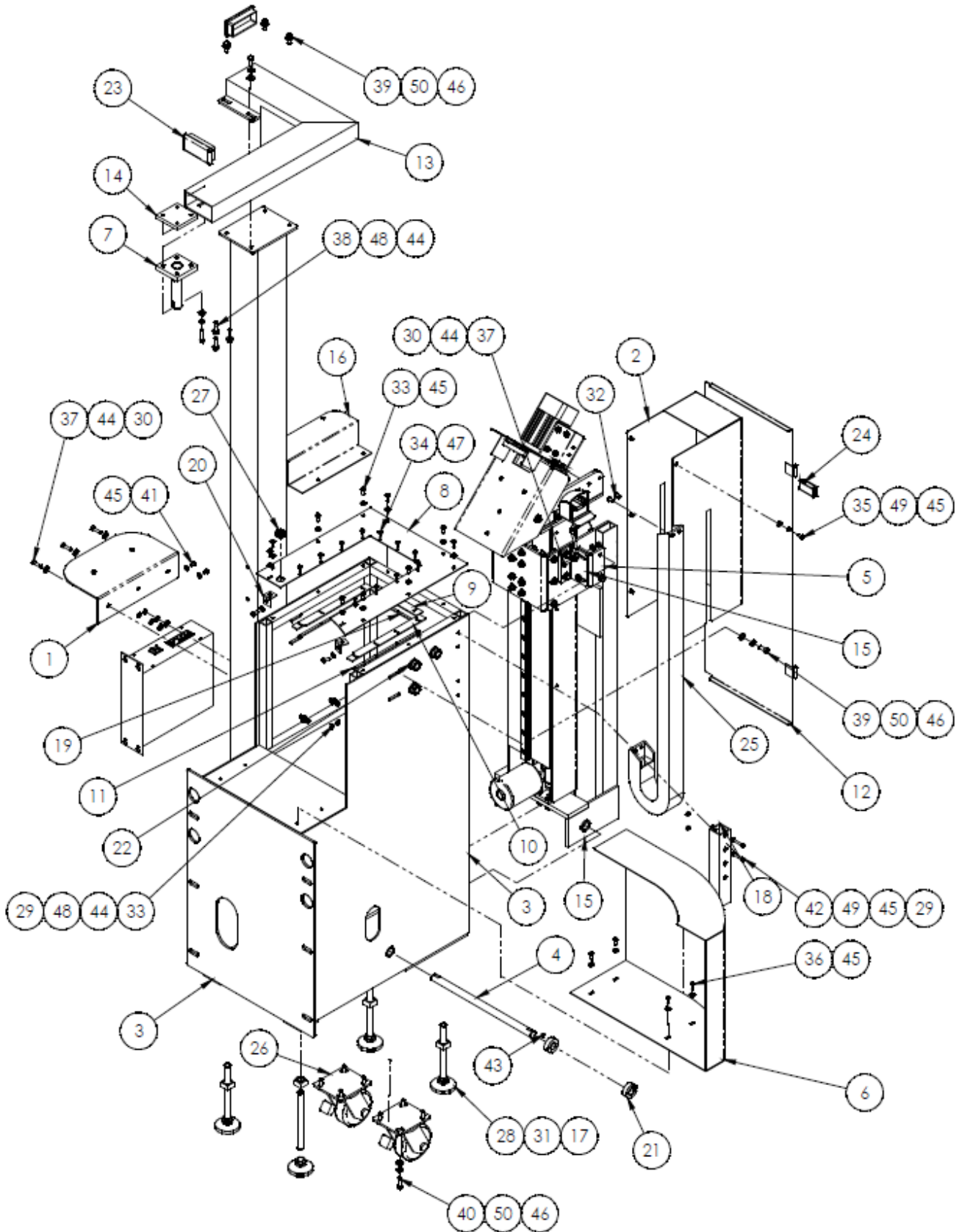

1315300 parts list

NO.	QTY	PART #	DESCRIPTION
1	1	1315123	MOUNT, EFKA
2	1	1315124	COVER, COLUMN
3	1	1315125	CONSOLE BASE, WELDMENT
4	1	1315128	AXLE, COLUMN
5	2	1315130	MOUNT, CONSOLE
6	1	1315138	COVER, WELDMENT
7	1	1315144	AXEL, PIVOT
8	1	1315146	COVER, CONSOLE
9	1	1315148	WIPER, COLUMN SHORT
10	2	1315149	WIPER, COLUMN LONG
11	2	1315150	PLATE, NUT 6-32
12	1	1315151	DOOR, BACK
13	1	1315161	PIVOT WELDMENT, TOP
14	1	1315162	PLATE, NUT TOP PIVOT
15	1	1315200	ASSY, COLUMN
16	1	1315340	BRKT, THREAD GUIDE
17	4	1315661	ROD, THREADED, 5/8-11X7LG
18	1	13453385	HOLDER, SCISSOR
19	1	13453652	PLATE,NUT,6-32,3PL@2.5 OC
20	2	98-6819A	CORNER BKT
21	2	CCCL12F	CLAMP COLLAR- 3/4
22	3	FF274-416	KNOB,SPEED CONTROL
23	2	MM132-2X4	END CAP,RECT,BLACK
24	1	MM40450010	FASTENER,SLIDE LOCK
25	1	MM45021-26	DUCT,WIRE PLASTITRAK
26	2	MM644001PHNTLB	CASTER, 4" SWIVEL W/BRAKE
27	1	MM9600K21	GROMMET,RUBBER,9/16 ID
28	4	MML-2	LEVELING PAD, 5/8-11
29	4	NNH10-32	#10-32 HEX NUT
30	10	NNK1/4-20	KEP NUT, 1/4-20
31	4	NNSH5/8-11	NUT, SQUARE, 5/8-11
32	2	SSBC01032	1/4-20 X 1/2 BUT HEAD
33	18	SSBC01040	1/4-20 X 5/8 BUT HEAD
34	11	SSBC80032	#6-32 X 1/2 BUT HEAD
35	6	SSBC98032	#10-32 X 1/2 BUT HEAD
36	7	SSHC01064	1/4-20 X 1 HEX HEAD
37	4	SSHC01080	1/4-20 X 1-1/4 HEX HEAD
38	8	SSHC10048	5/16-18 X 3/4 HEX HEAD
39	8	SSHC10064	5/16-18 X 1" HEX HEAD
40	4	SSPP98024	#10-32 X 3/8 PAN HD PHIL
41	2	SSSC98048	#10-32 X 3/4 SOC CAP
42	4	SSSS01024	1/4-20 X 3/8 KNURL PT
43	23	WWFS1/4	WASHER FLAT, 1/4
44	28	WWFS10	WASHER, FLAT #10
45	16	WWFS5/16	WASHER, FLAT, 5/16
46	11	WWFS6	WASHER, FLAT, #6
47	6	WWL1/4	1/4 LW
48	8	WWL10	#10 LW
49	16	WWL5/16	5/16 LW

1315200 Column Assembly

AAC Drawing Number 1315200 Rev 6

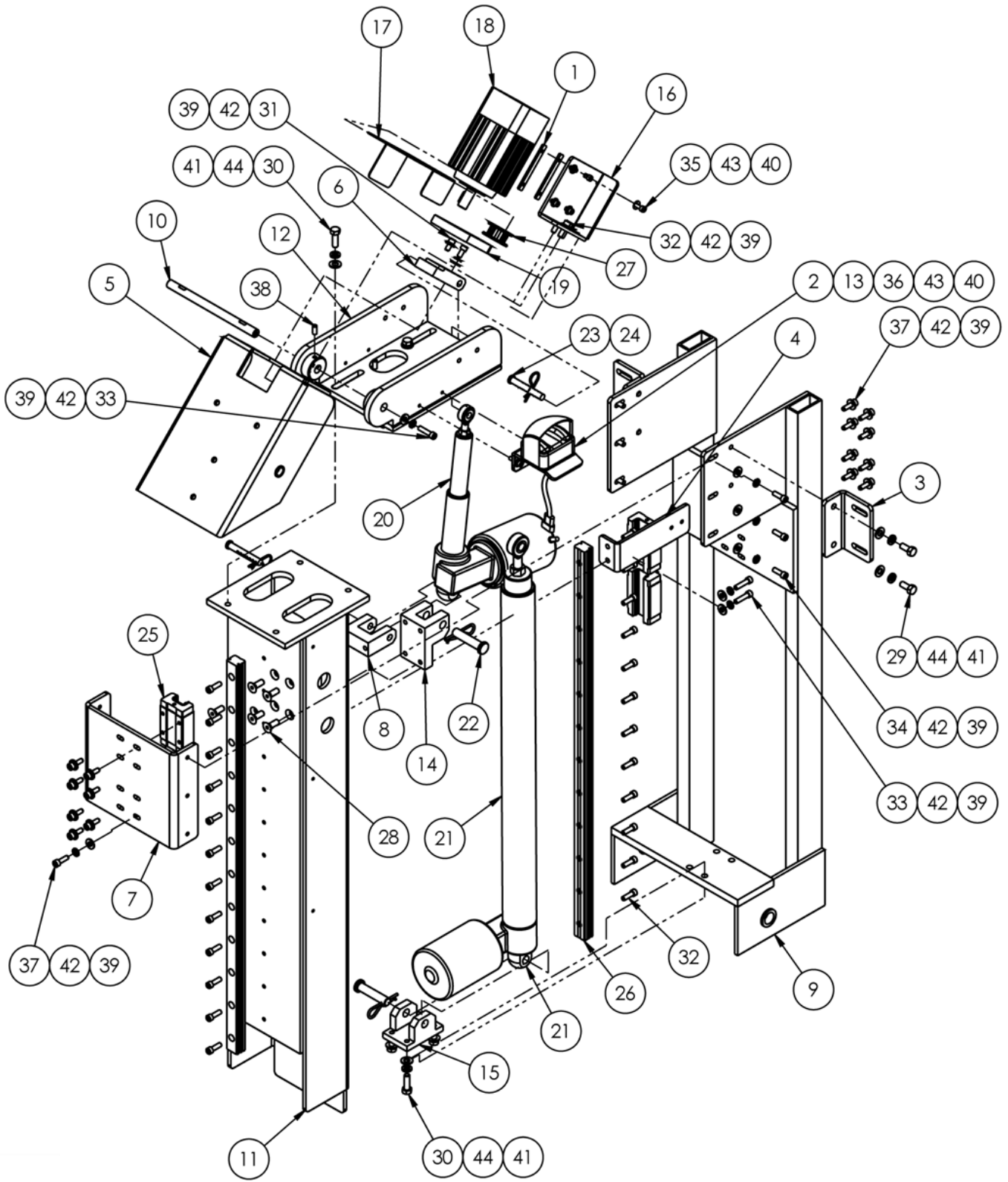

1315200 parts list

ITEM NO.	QTY	PART NUMBER	DESCRIPTION
1	2	0211-209	PLATE,NUT,10-32@2.25 CTC
2	1	1278-6602A	TOUCH SWITCH ASSY W /3 PIN
3	2	1315129	MOUNT, COLUMN
4	1	1315132	MOUNT, CABLETRAK COLUMN
5	1	1315276	PLATE, SEWING HEAD MOUNT
6	1	1315277	MOUNT, ROD END
7	1	1315279	MOUNT, COLUMN FRONT
8	1	1315282	PIVOT, SUPPORT, ACTUATOR
9	1	1315297	ASSY, COLUMN BASE
10	1	1315313	SHAFT, SEW PIVOT
11	1	1315530	COLUMN, SEWING HEAD
12	1	1315536	WELDMENT, SEW HEAD PIVOT
13	1	1315652	BRACKET, TOUCH SWITCH
14	1	1349012	BLOCK, PIVOT UPPER
15	1	1349013	MOUNT, LIFT LOWER
16	1	13453608	BRKT, MOTOR MOUNT
17	1	13453612	BELT, GUARD
18	1	4059-DC1500ABA2	MOTOR & CONTROLLER
19	1	GG124L050	BELT, 3/8P, 33 TH, 1/2 W
20	1	MM85151-2M2	ACTUATOR, MOD
21	1	MM85199-20M1	ACTUATOR, ELEC. LINEAR
22	2	MM97245A718	CLEVIS PIN WITH SPG PIN
23	2	MM98330A245	CLEVIS PIN 2.25LG STL
24	2	MM98335A064	SPRING CLIP
25	4	MMEGH25CA	LINEAR BEARING
26	2	MMAGR25710N	RAIL, LINEAR, AG SERIES
27	1	PP10LF050M3	PULLEY,GEAR,3/8P,10T,14MM
28	6	SSFC10056	5/16-18 X 7/8 FLAT HD CAP
29	4	SSHC10048	5/16-18 X 3/4 HHCS
30	8	SSHC10064	5/16-18 X 1 HHCS
31	2	SSSC01032	1/4-20X1/2 SOC CAP
32	27	SSSC01048	1/4-20 X 3/4" SOC CAP SC
33	4	SSSC01064	1/4-20 X 1 SOC CAP
34	6	SSSC05048	1/4-28 X 3/4, SOC CAP
35	4	SSSC98032	10-32X1/2, SOC CAP
36	2	SSSC98048	10-32 X 3/4 SOC CAP
37	16	SSSCM6X20	M6 X 20, SOC CAP
38	4	SSSS01040	SCREW, SET, 1/4-20 X 5/8
39	31	WWFS1/4	WASHER,FLAT,SAE,1/4
40	6	WWFS10	WASHER, FLAT, # 10, SAE
41	12	WWFS5/16	WASHER,FLAT,SAE,5/16
42	31	WWL1/4	WASHER,LOCK, 1/4
43	6	WWL10	WASHER,LOCK,# 10
44	12	WWL5/16	WASHER,LOCK, 5/16

1315327 parts list

NO	QTY	PART #	DESCRIPTION
1	1	1315060	ASSY,FOOTPEDAL
2	2	1315339	ROLLER, TOP
3	1	1315341	AXLE, TOP ROLLERS
4	1	1315354	COVER, TOWER
5	1	1315355	BLOCK, PIVOT TOWER
6	1	1315380	ASSY, BASE PLATFORM
7	1	1315385	RISER, WELDMENT
8	1	1315386	ASSY, RISER, .5 FRONT
9	1	1315387	RISER, .5 REAR WELDMENT
10	1	1315388	PLATFORM WELDMENT
11	2	1315389	ASSY, ROLLER SMALL
12	1	1315391	SPACER, ROLLER
13	1	1315593	BLOCK, POSITIONING LIFT
14	1	1315617	MAT, PLATFORM, CUT
15	4	1315631	SPACER, PLATFORM LIFT
16	2	BBT706	BEARING,BRONZE,OD.75X.5 .
17	2	CCCL8F	CLAMP COLLAR- 1/2
18	1	MM85199-12	ACTUATOR, ELEC. LINEAR 12
19	2	MM97245A718	CLEVIS PIN WITH SPG PIN
20	4	MMSH62STPA	RING,SNAP,EXTERNAL
21	2	NNE1/2-13	NUT, ELASTIC 1/2-13
22	6	NNE1/4-20	NUT,ELASTIC LOCK,1/4-20
23	2	NNE10-32	NUT,ELASTIC LOCK
24	2	NNK1/4-20	KEP NUT, 1/4-20
25	*1	SI-120-M	CYANOCRYLATE ADHESIVE
26	2	SSAS024096	3/8 X 1-1/2 X 5/16-18 SHLD, BOLT
27	4	SSBC01096	1/4-20 X 1-1/2 BUT HEAD
28	6	SSBC98024	#10-32 X 3/8 BUT HEAD
29	2	SSHC01048	1/4-20 X 3/4 HEX HEAD
30	2	SSPS98096	#10-32 x 1-1/2 LG PHS
31	2	SSSC01064	1/4-20 X 1 SOC CAP
32	4	UUAA628-10	BEARING,BRONZE,.5015ID
33	2	UUAA630-12	BEARING,BRONZE,.5015ID
34	2	UUFF102-6	BEARING,FLG,1.003X1.254
35	4	UUFF703-03	BEARING,BRONZE,.6265 ID
36	2	WWFS1/2	1/2 FLAT WASHER
37	14	WWFS1/4	WASHER FLAT, 1/4
38	2	WWFS5/16	WASHER, FLAT, 5/16
39	8	WWFS10	WASHER, FLAT #10
40	2	WWL1/4	1/4 LW

1315060 Foot Pedal Assembly

AAC Drawing Number 1315060 Rev 0

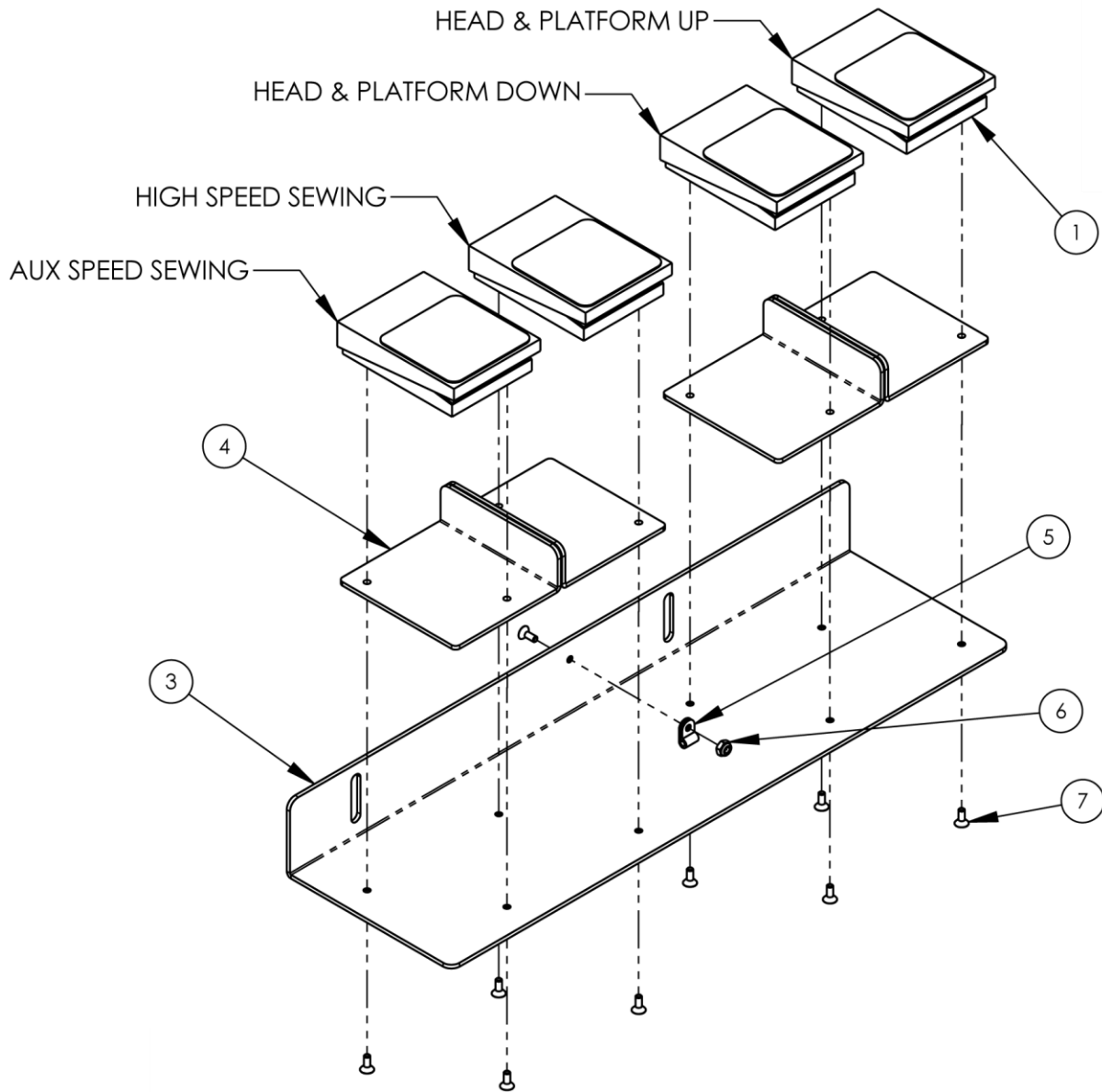

NO.	QTY	PART #	DESCRIPTION
1	4	1278-6161	FOOT SWITCH MODIFICATION
2	1	1315-010	CABLE, FOOT PEDAL
3	1	1315047	PLATE, PEDAL MOUNT
4	4	1315048	GUARD, PEDAL
5	1	AAF1/8	1/8" PLASTIC CLAMP
6	1	NNE6-32	NUT, ELASTIC LOCK, 6-32
7	9	SSFC80024	#6-32 X 3/8 FLAT ALLEN

1315400 Flipper Assembly

AAC Drawing Number 1315400 Rev 7

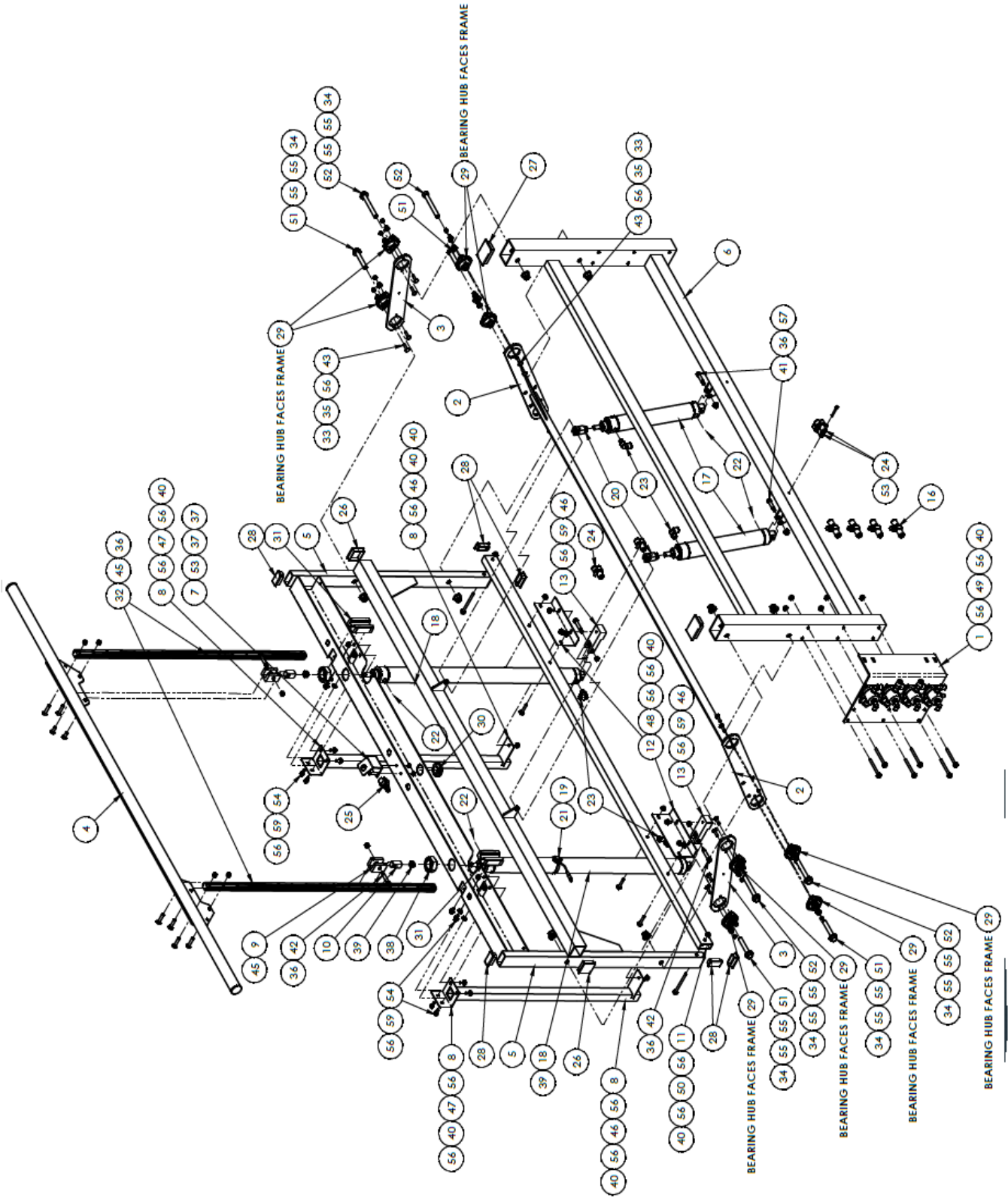

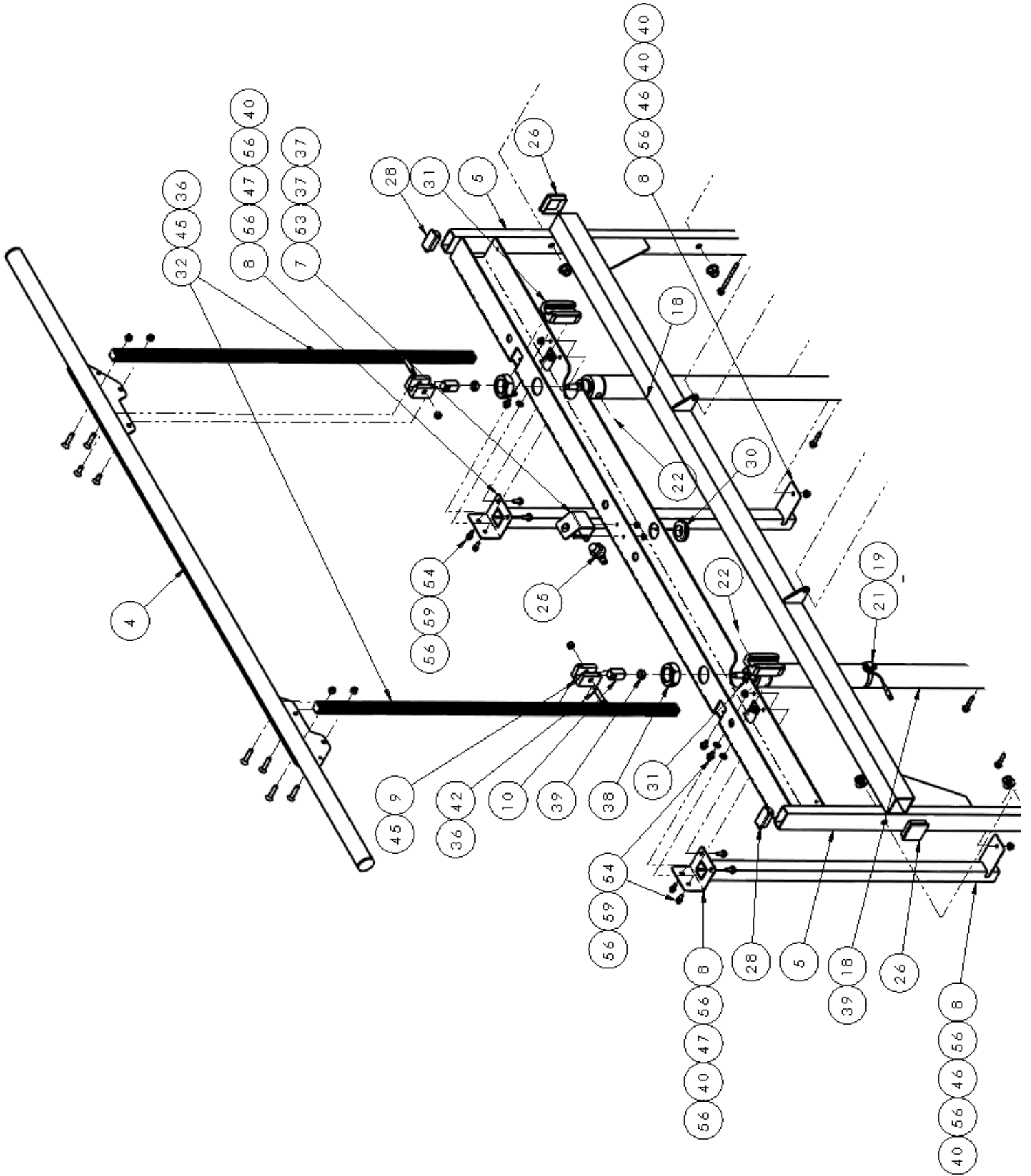

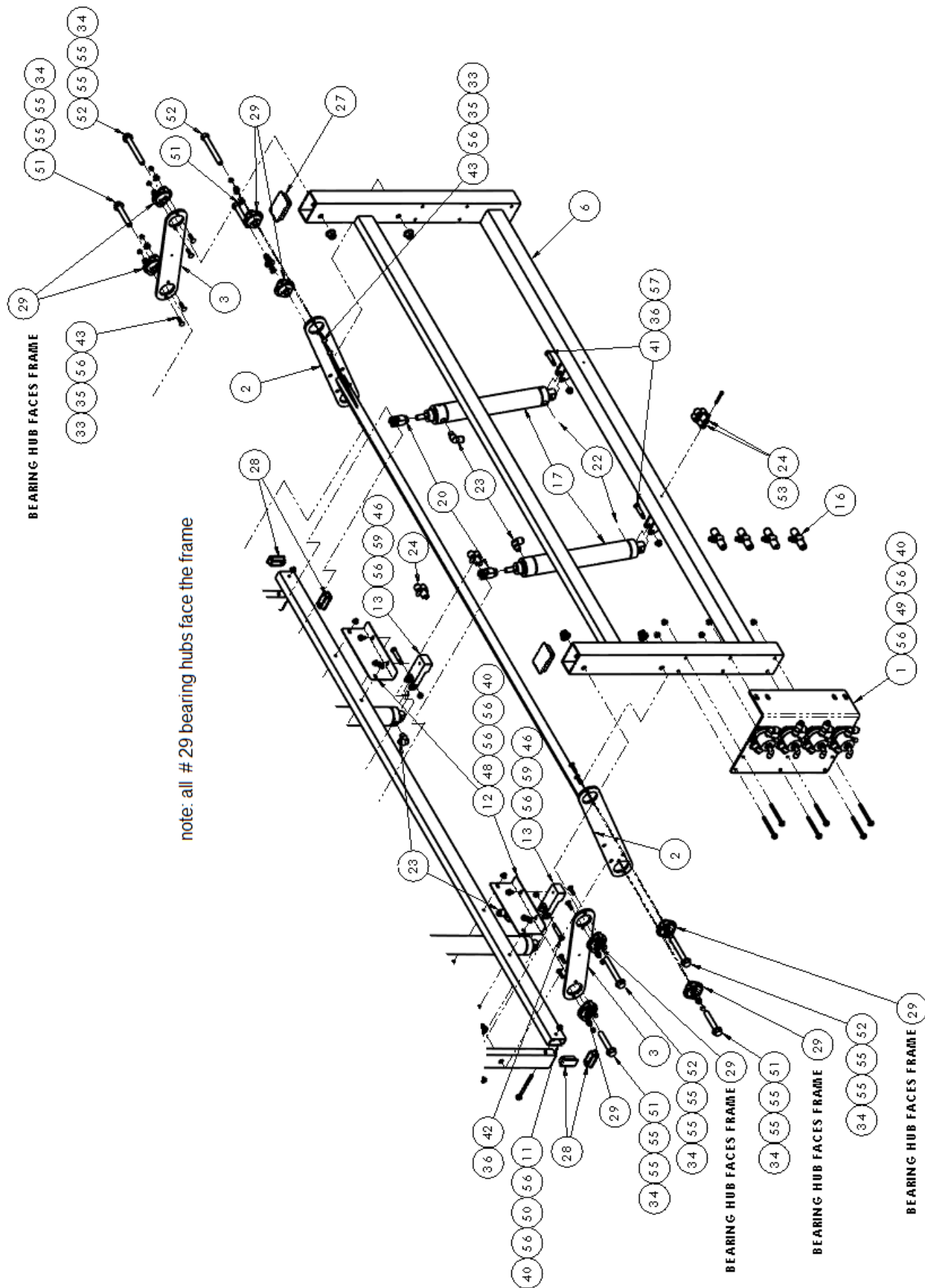

1315400 parts list

ITEM NO.	QTY	PART NUMBER	DESCRIPTION	ITEM NO.	QTY	PART NUMBER	DESCRIPTION
1	1	1315095	PILOT VALVE ASSY MOUNT	31	2	MMEGH25CA	LINEAR BEARING
2	1	1315397	LINK, FLIP LOWER	32	2	MMEGR25R0992CM	RAIL, LINEAR AG SERIES
3	2	1315401	LINK, FLIP UPPER	33	16	NNC1/4-20	NUT, CAP, 1/4-20
4	1	1315408	ASSY, TUBE FLIP	34	8	NNE1/2-13	NUT, ELASTIC 1/2-13
5	1	1315409	ASSY, FLIP	35	16	NNE1/4-20	NUT, ELASTIC LOCK, 1/4-20
6	1	1315410	MOUNT, FLIP TO TABLE	36	10	NNE5/16-18	NUT, ELASTIC LOCK, 5/16-18
7	1	1315434	BRACKET, SENSOR FLIP EDGE	37	2	NNH10-32	#10-32 HEX NUT
8	2	1315452	ASSY, RAIL COVER	38	2	NNJ1-1/4-12	1-1/4-12 HEX JAM NUT
9	2	1315633	BLOCK, FOR CYL	39	2	NNJ1/2-20	1/2-20 HEX JAM NUT
10	2	1315634	COUPLING, CYL FLIPPER	40	18	NNK1/4-20	KEP NUT, 1/4-20
11	1	1315653	TUBE, CYL SUPPORT	41	2	SSAS024080	3/8X1-1/4, 5/16-18SHLDBOLT
12	2	1315654	SUPPORT, RAIL AND CYL	42	4	SSAS024096	3/8 X 1-1/2 X 5/16-18 SHLD, BOLT
13	2	1315655	SUPPORT, CYL	43	16	SSBK01064	1/4-20 X 1 BOLT, CARG
14	1	9900752	SHIPPING BRACKET	44	2	SSFC10056	5/16-18 X 7/8 FLAT ALLEN
15	1	9900753	SHIPPING BRACKET	45	6	SSFC10096	5/16-18 X 1-1/2 FLAT ALLEN
16	4	AA3001F-11	FLOW CONT, INLINE, 3/8 LINE	46	4	SSHC01040	1/4-20 X 5/8 HEX HEAD
17	2	AACCM3110DXP	CYLINDER, AIR, DA, W/MAGNET	47	4	SSHC01048	1/4-20 X 3/4 HEX HEAD
18	2	AACCM3130DXP	CYLINDER, AIR, DA, W/MAGNET	48	4	SSHC01096	1/4-20 X 1-1/2 HEX HEAD
19	1	AAEHSKQ	SWITCH, HALL EFFECT BIMBA	49	6	SSHC01192	1/4-20 X 3 HEX HEAD
20	2	AAFD2313	CLEVIS, AIR CYL 7/16-20	50	2	SSHC01224	1/4-20 X 3-1/2 HEX HEAD
21	1	AAFD35875-14	BAND, CYLINDER, HSKQ HAL	51	4	SSHC45192	1/2-13 X 3 HEX HEAD
22	4	AAQMC-3-4	QUICK MALE CONNECTOR	52	4	SSHC45256	1/2-13 X 4 HEX HEAD
23	4	AAQME-3-4	MALE ELBOW 3/8OD TUBE	53	3	HX-SHCS0.19-	
24	4	AAQUY-3-3	QUICK UNION Y 3/8 X 3/8	54	8	SSSCM6X16	M6-1.0 X 16 SOC CAP
25	1	FFT18FF100Q	EYE, FIXED FIELD, 4IN	55	16	WWFS1/2	WASHER, FLAT, 1/2
26	2	MM132-2X2A	END CAP, SQUARE, BLACK	56	62	WWFS1/4	WASHER FLAT, 1/4
27	2	MM132-2X3	END CAP, RECT, BLACK, 2X3	57	2	WWFS5/16	WASHER, FLAT, 5/16
28	6	MM132-1496	PLUG 1 X 2	58	2	WWFS10	WASHER, FLAT #10
29	8	MM5913K51	BEARING, FLANGE, 1/2 BORE	59	10	WWL1/4	1/4 LW
30	1	MM9307K74	GROMMET, 3/4ID, 1.38OD, .13GV	60	2	WWL10	#10 LW

1315095 Pilot Valve Assembly

AAC Drawing Number 1315095 Rev 0

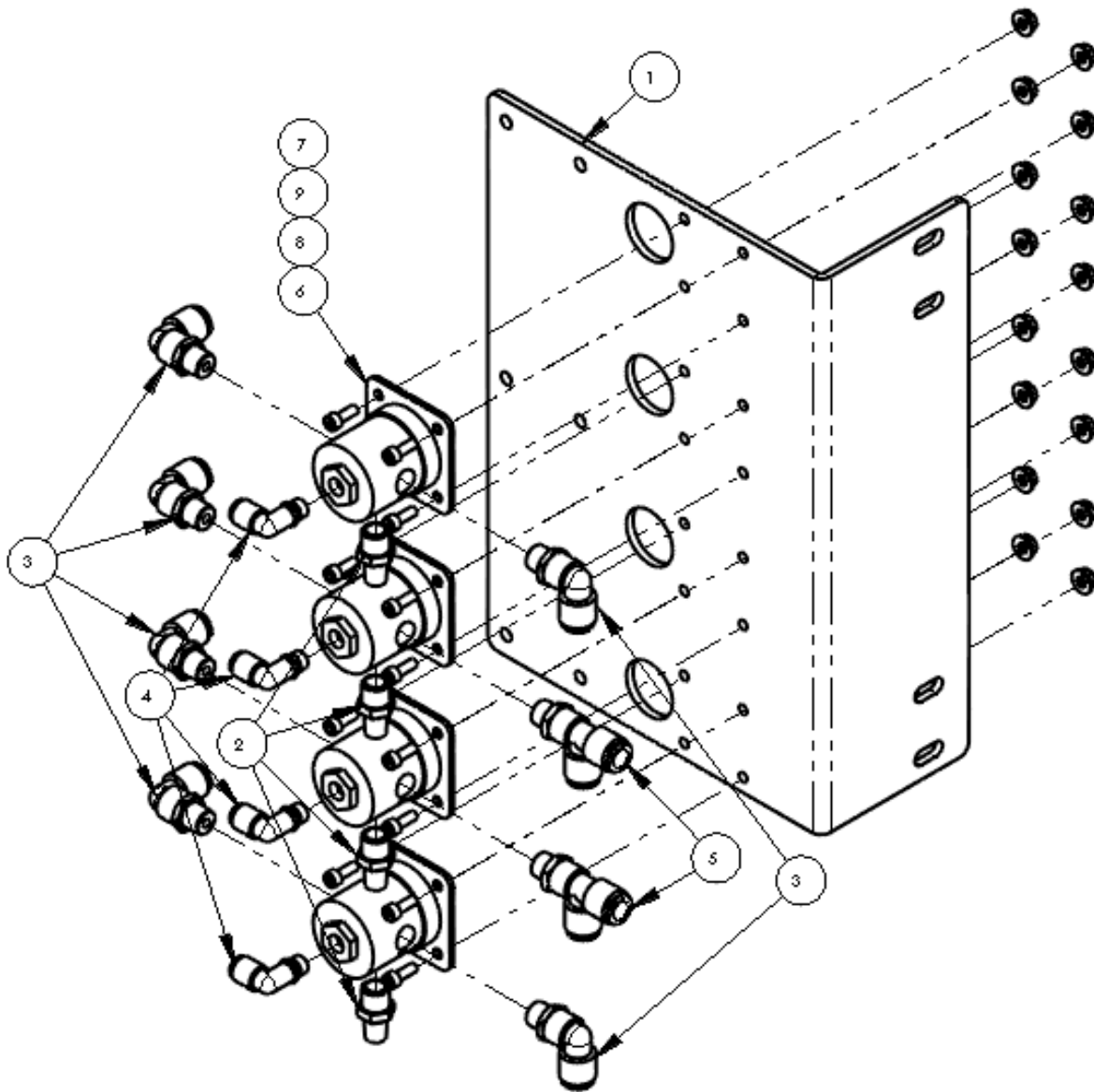

ITEM NO.	QTY.	PART NUMBER	DESCRIPTION
1	1	131 5318	MOUNT, FLIP
2	4	AAFP28	MUFFLER, 1/4 NPT
3	6	AAQME-3-4	MALE ELBOW 3/8OD TUBE
4	4	AAQME-4-8	QUICK MALE ELBOW, 1/4T
5	2	AAQMT-3-4	MALE RUN TEE
6	4	AAV250A	PILOT VALVE
7	16	NNK10-32	KEP NUT, 10-32
8	16	SSSC98032	10-32 X 1/2, SOC CAP
9	16	WWFS10	WASHER, FLAT, #10, SAE

1315430 Pneumatic Panel

AAC Drawing Number 1315430 Rev 4

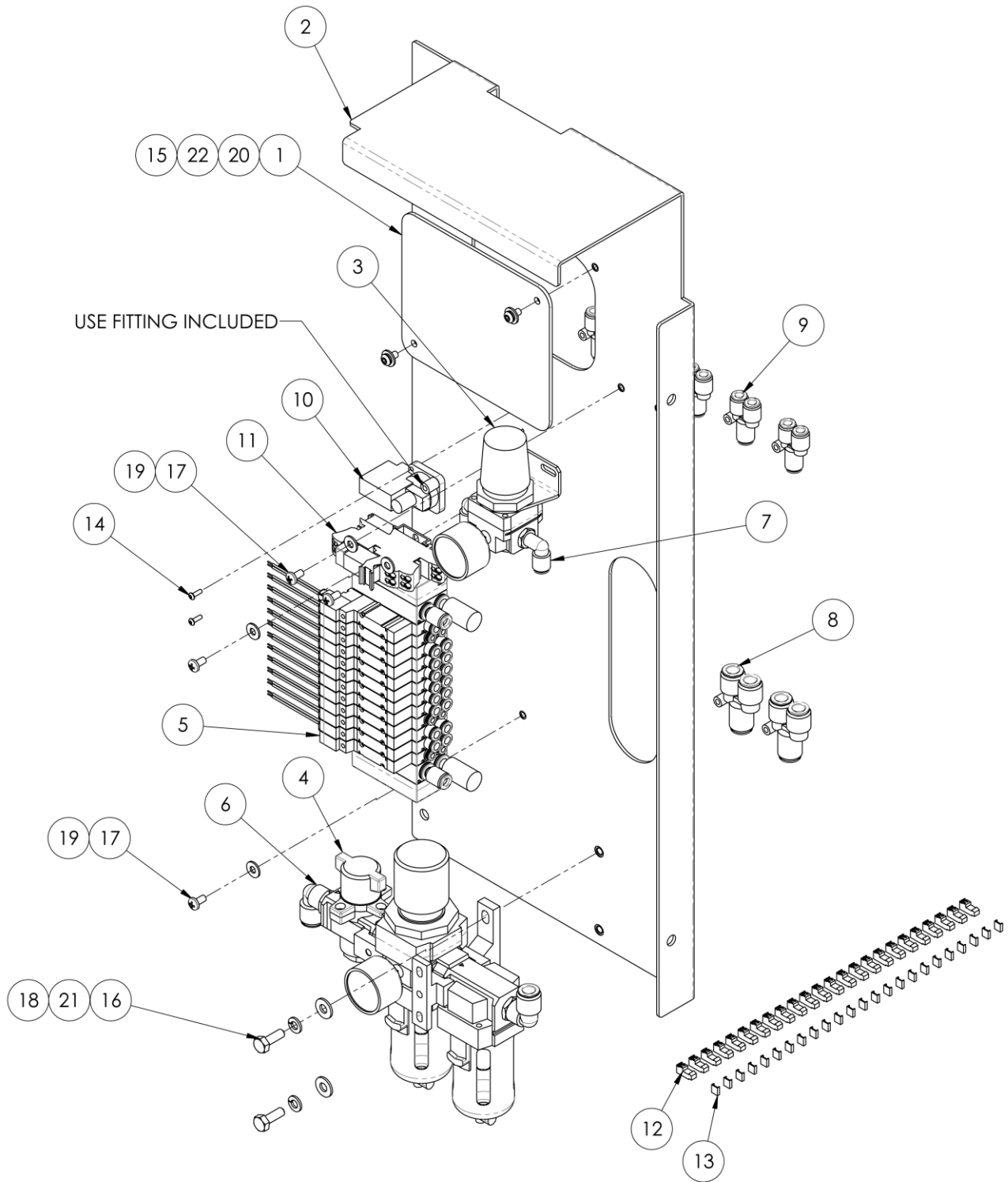

1315430 parts list

NO	QTY	PART #	DESCRIPTION
1	1	1315209	COVER
2	1	1315566	PANEL, PNEUMATIC
3	1	AA198-508	REGULATOR, 0-160 W/GAUGE
4	1	AA198-5110	FILTER/REGULATOR/LOCKOUT
5	1	AAE1315-12	SOLENOID ASSY, 12 STATION
6	2	AAQME-3-4	MALE ELBOW 3/8OD TUBE
7	2	AAQME-4-4	ELBOW, MALE, 1/4X1/4NPT
8	2	AAQUY-3-3	QUICK UNION Y 3/8 X 3/8
9	5	AAQUY-4-4	Y UNION, 1/4X1/4
10	1	AAVF51FM1B	AIR/ELEC PRESSURE SW
11	1	EE788304	RELAY, 24V, SPDT, WAGO
12	24	FF100F2202	CONNECTOR, 2 PIN, RED
13	24	FFSC10002	COVER, STRAIN RELIEF
14	2	SSBC70024	#4-40 X 3/8 BUT HEAD
15	2	SSBC98024	10-32 X 3/8 BUTTON CAP SC
16	2	SSHCO1048	1/4-20 X 3/4 HEX HEAD
17	4	SSPP98024	#10-32 X 3/8 PAN HD PHIL
18	2	WWFS1/4	WASHER FLAT, 1/4
19	4	WWFS10	WASHER, FLAT #10
20	2	WWFS10	WASHER, FLAT, #10, SAE
21	2	WWL1/4	1/4 LW
22	2	WWL10	WASHER, LOCK, #10

1315450 Tape Guide Assembly

AAC Drawing Number 1315450 Rev 2

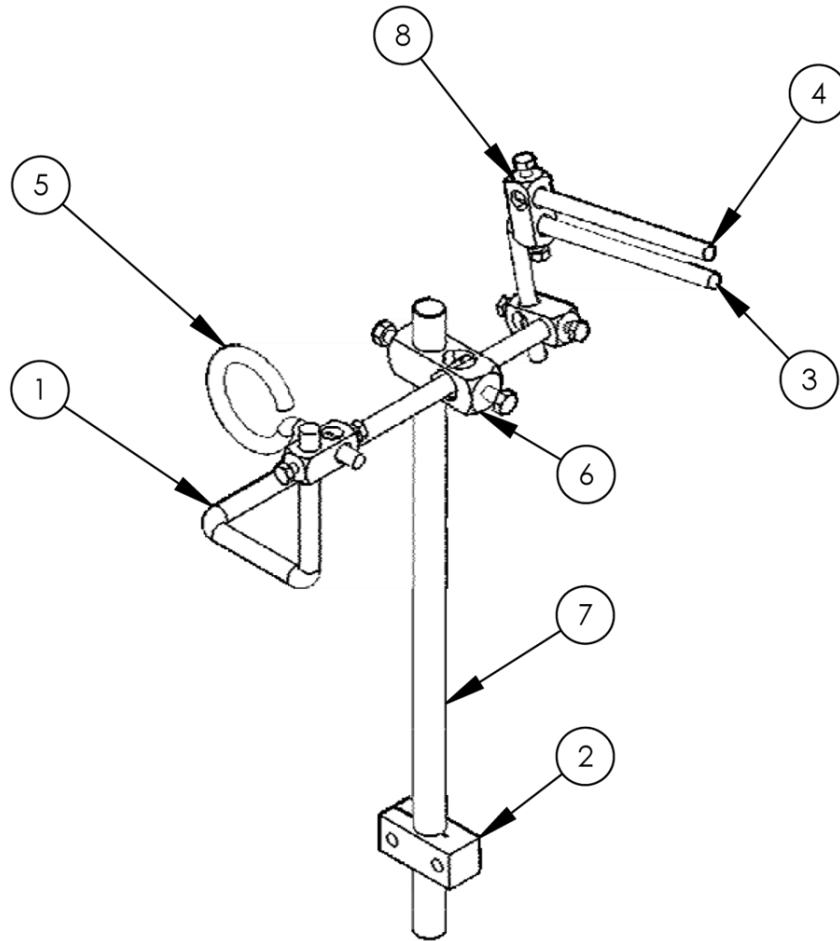

NO.	QTY	PART #	DESCRIPTION
1	1	1315174	ROD, BENT, 1/2 CRS
2	1	1315475	CLAMP, 3/4 ROD
3	1	1335-316	ROD, SS, "L", 3/8, 4.0 X
4	1	1335-320	ROD,S/S,3/8,6.5L
5	1	1338-028	RING,TAPE GUIDE
6	1	28201	BLOCK,CROSS,(LARGE)
7	1	28202	ROD,STRAIGHT,1018
8	3	A-U	ROD CROSS BLOCK

1315479 Air Jet Assembly; (Right Side)

AAC Drawing Number 1315479 Rev 1

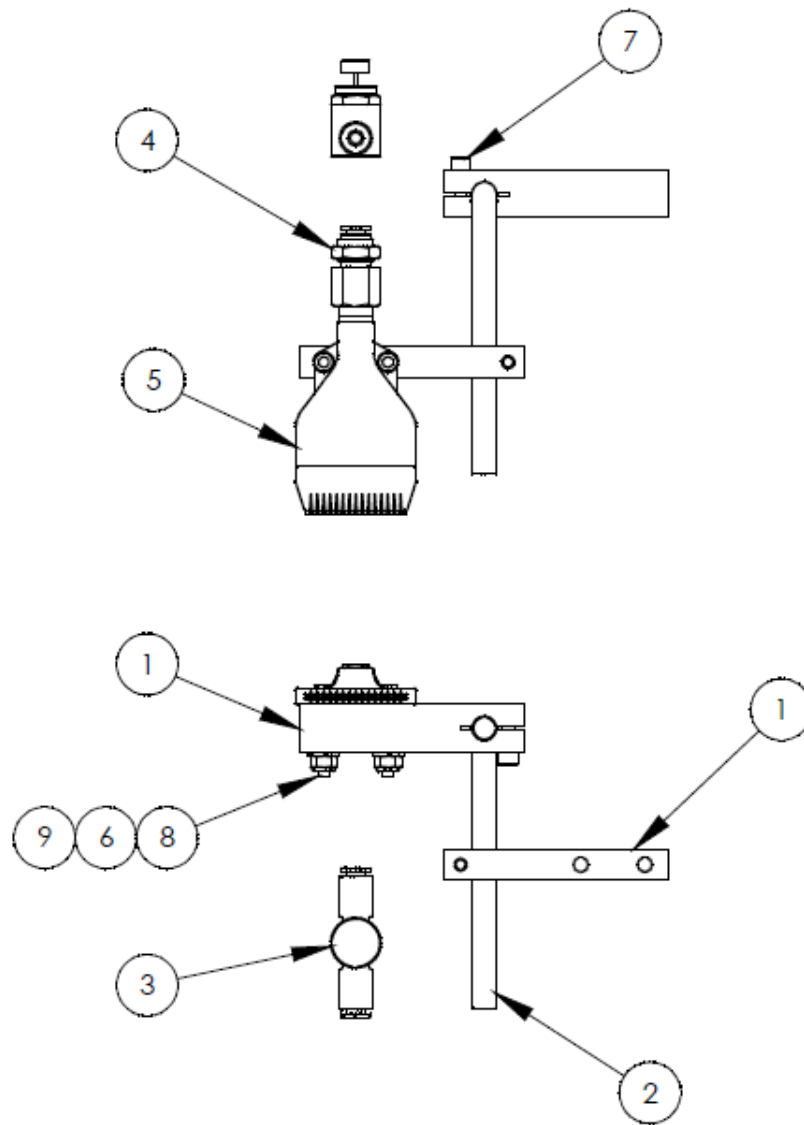

RIGHT SIDE ASSEMBLY

ITEM NO.	QTY	PART NUMBER	DESCRIPTION
1	2	1315477	BLOCK, CLAMP 3/8 ROD
2	1	1315478	ROD, 3/8" AIR JET MOUNT
3	1	AA3001F-03	FLOW CONT,INLINE,1/4 LINE
4	1	AAQBC-4-4	BULKHEAD CONN,1/4QUICK
5	1	MM5329K21	AIR NOZZLE
6	2	NNE10-32	NUT,ELASTIC LOCK
7	2	SSSC98048	10-32 X 3/4 SOC CAP
8	2	SSSC98080	10-32 X 1-1/4 SOC CAP
9	2	WWFS10	WASHER, FLAT, #10, SAE

1315483 Air Jet Assembly; (Left Side)

AAC Drawing Number 1315483 Rev 0

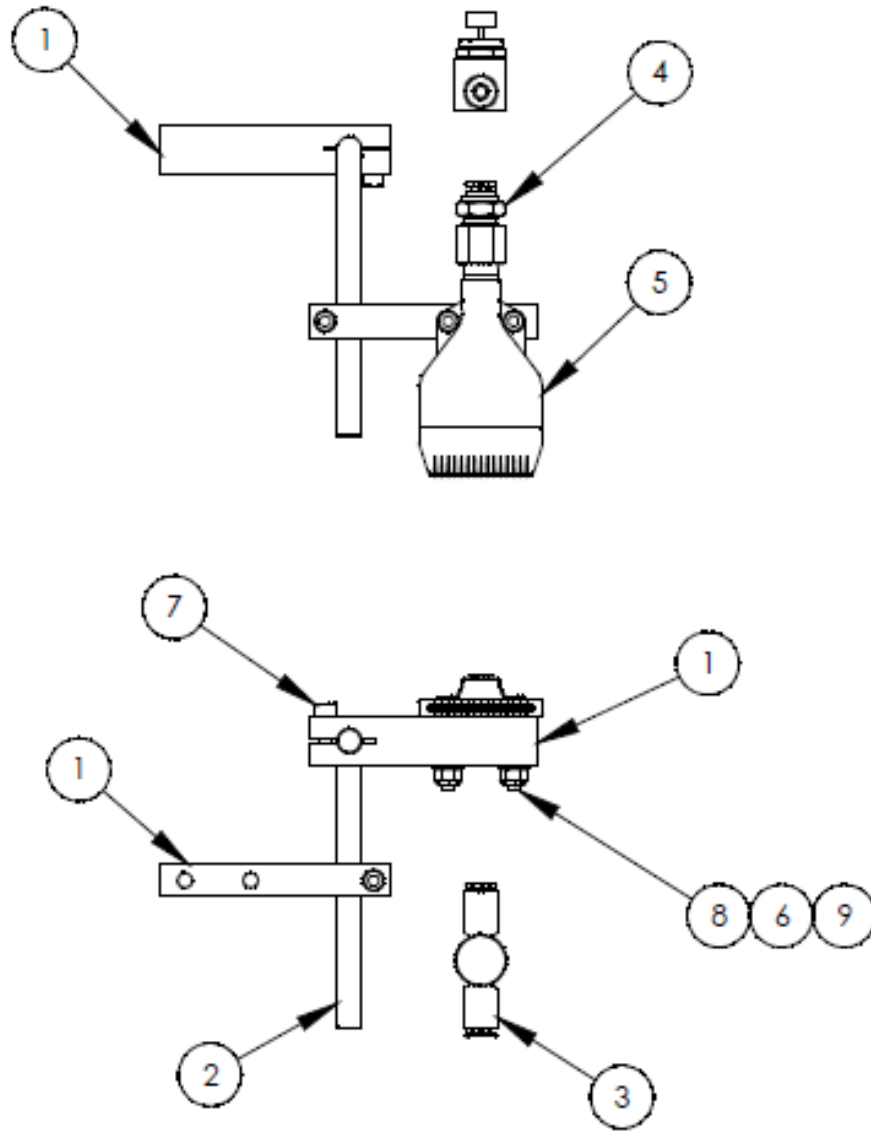

LEFT SIDE ASSEMBLY

ITEM NO.	Hardware Shown/QTY	PART NUMBER	DESCRIPTION
1	2	1315477	BLOCK, CLAMP 3/8 ROD
2	1	1315478	ROD, 3/8" AIR JET MOUNT
3	1	AA3001F-03	FLOW CONT, INLINE, 1/4 LINE
4	1	AAQBC-4-4	BULKHEAD CONN, 1/4 QUICK
5	1	MM5329K21	AIR NOZZLE
6	2	NNE10-32	NUT, ELASTIC LOCK
7	2	SSSC98048	10-32 X 3/4 SOC CAP
8	2	SSSC98080	10-32 X 1-1/4 SOC CAP
9	2	WWFS10	WASHER, FLAT, #10, SAE

1315498 Push Plate Assembly

AAC Drawing Number 1315498 Rev 2

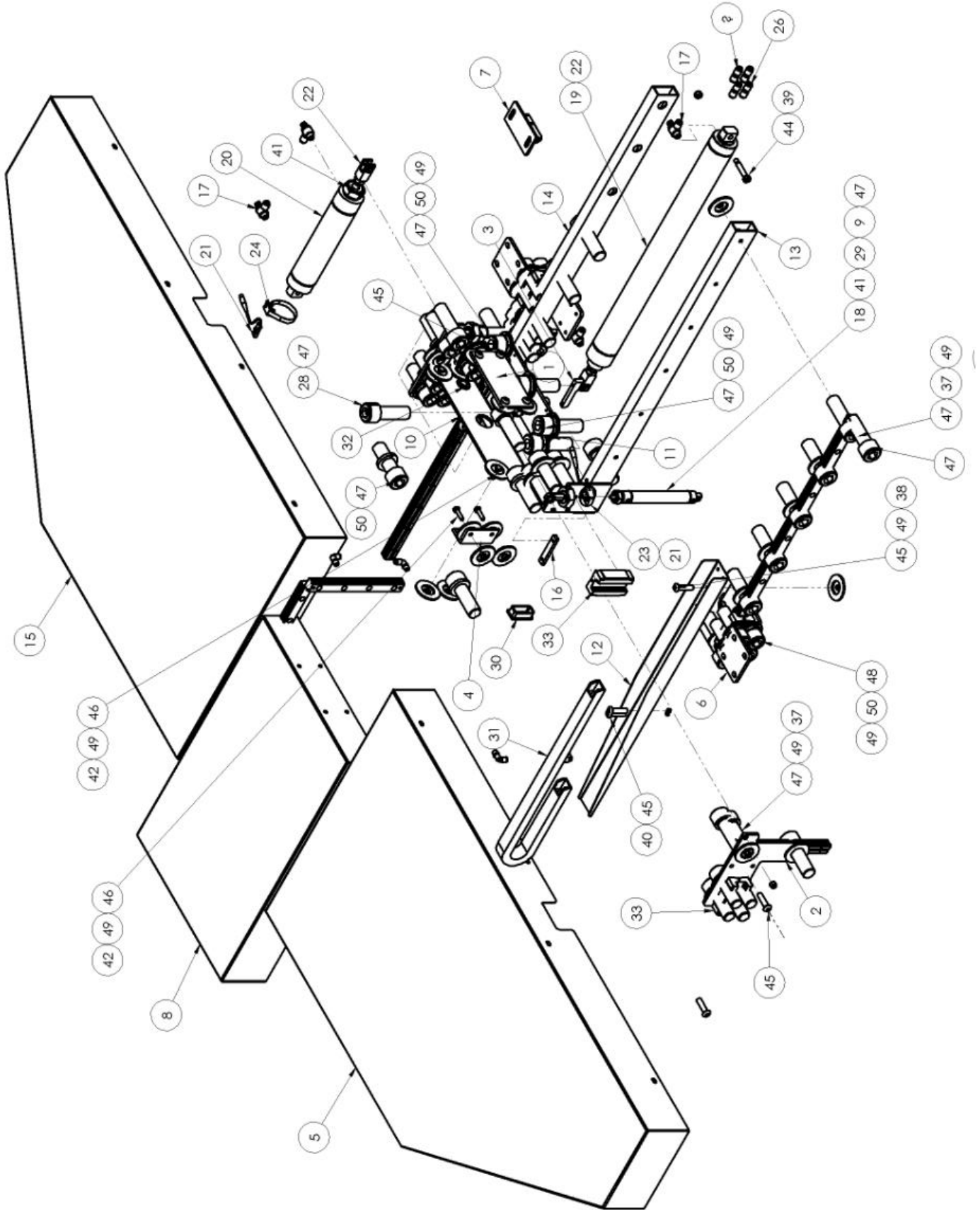

1315498 parts list

NO.	QTY	PART #	DESCRIPTION	NO.	QTY	PART #	DESCRIPTION
1	1	1315465	ASSY, CYL. MOUNT PUSHER	31	1	MM18222837	DUCT, WIRE MICROTRAK
2	2	1315537	MOUNT, BEARING AND RAIL	32	1	MM2761	GROMMET, .50 ID X 3/16 GR
3	1	1315543	MOUNT, CYLINDER HORZ	33	6	MMAGH25CAN	LINEAR BEARING
4	2	1315549	BRACKET, L	34	2	MMAGR25220M	MOD, RAIL 220MM
5	1	1315550	TRAY WELDMENT, RIGHT	35	2	MMAGR25303M	MOD, RAIL BRG 303MM
6	2	1315553	MOUNT, PUSHER TO FRAME	36	2	MMAGR25650M	MOD, RAIL 650MM
7	1	1315554	MOUNT, CYL TO FRAME	37	22	NNE1/4-20	NUT, ELASTIC LOCK, 1/4-20
8	1	1315555	PUSHER TRAY	38	4	NNE10-32	NUT, ELASTIC LOCK
9	2	1315557	SPACER, ROD END	39	1	NNE5/16-18	NUT, ELASTIC LOCK, 5/16-18
10	1	1315565	MOUNT, HORZ. CYL	40	2	NNE6-32	NUT, ELASTIC LOCK, 6-32
11	1	1315567	PLATE, CYL MOUNT	41	1	NNJ1-1/4-12	1-1/4-12 HEX JAM NUT
12	1	1315576	TRAY, SUPPORT WIRE DUCT	42	2	NNJ1/4-28	1/4-28 HEX JAM NUT
13	1	1315578	ASSY, CYL. MOUNT RIGHT	43	7	NNK1/4-20	KEP NUT, 1/4-20
14	1	1315580	ASSY, RAIL MOUNT LEFT	44	1	NNK8-32	KEP NUT, 8-32
15	1	1315582	TRAY WELDMENT, LEFT	45	1	SSAS024096	3/8 X 1-1/2 X 5/16-18 SHLD, BOLT
16	2	96-5606	PLATE, NUT 2.0 CTC 1/4	46	4	SSBC01032	1/4-20 X 1/2 BUT HEAD
17	4	AA2201-07	FLOW CONTROL, 1/4TX1/4NPT	47	4	SSBC01048	1/4-20 X 3/4 BUT HEAD
18	2	AACM064DXP	CYLINDER, AIR, DA W/MAGNET	48	4	SSBC80032	#6-32 X 1/2 BUT HEAD
19	1	AACM3120DXP	CYLINDER, AIR, DA W/MAGNET	49	4	SSBC98040	#10-32 X 5/8 BUT HEAD
20	1	AACM316DXP	CYLINDER, AIR, 2" BORE	50	8	SSHC01064	1/4-20 X 1 HEX HEAD
21	2	AAEHSKQ	SWITCH, HALL EFFECT BIMBA	51	12	SSSC01024	1/4-20 X 3/8 SOC CAP
22	2	AAFD2313	CLEVIS, AIR CYLINDER	52	6	SSSC01048	1/4-20 X 3/4 SOC CAP
23	1	AAFD35456-8	BAND, 09 CYLINDER, HSKQ	53	12	SSSC01064	1/4-20 X 1 SOC CAP
24	1	AAFD35875-14	BAND, CYLINDER, HSKQ HAL	54	6	SSSC01080	1/4-20 X 1-1/4 SOC CAP
25	4	AAQME-5-8	QUICK MALE ELBOW	55	1	SSSC90080	#8-32 X 1-1/4 SOC CAP
26	2	AAQSU-4-4	UNION, QUICK STATION, 1/4X	56	24	SSSCM6X16	M6-1.0 X 16 SOC CAP
27	2	AAQSU-5-5	UNION, QUICK STATION, 5/32	57	66	WWFS1/4	WASHER FLAT, 1/4
28	2	AAQUY-5-5	QUICK UNION Y, 5/32	58	4	WWFS10	WASHER, FLAT #10
29	2	BBAW-4	BEARING, ROD END, FEMALE	59	34	WWL1/4	1/4 LW
30	2	MM132-1496	PLUG 1 X 2				

1315502 Table Assembly

AAC Drawing Number 1315502 Rev 4

PLEASE NOTE:
 OLDER MACHINES USE MAY USE
 GEARBOX SHAFT PART# 1315056
 1315056 HAS SHAFT OD = $\varnothing 1.437$ "
 1315084 HAS SHAFT OD = $\varnothing 1.249$ "

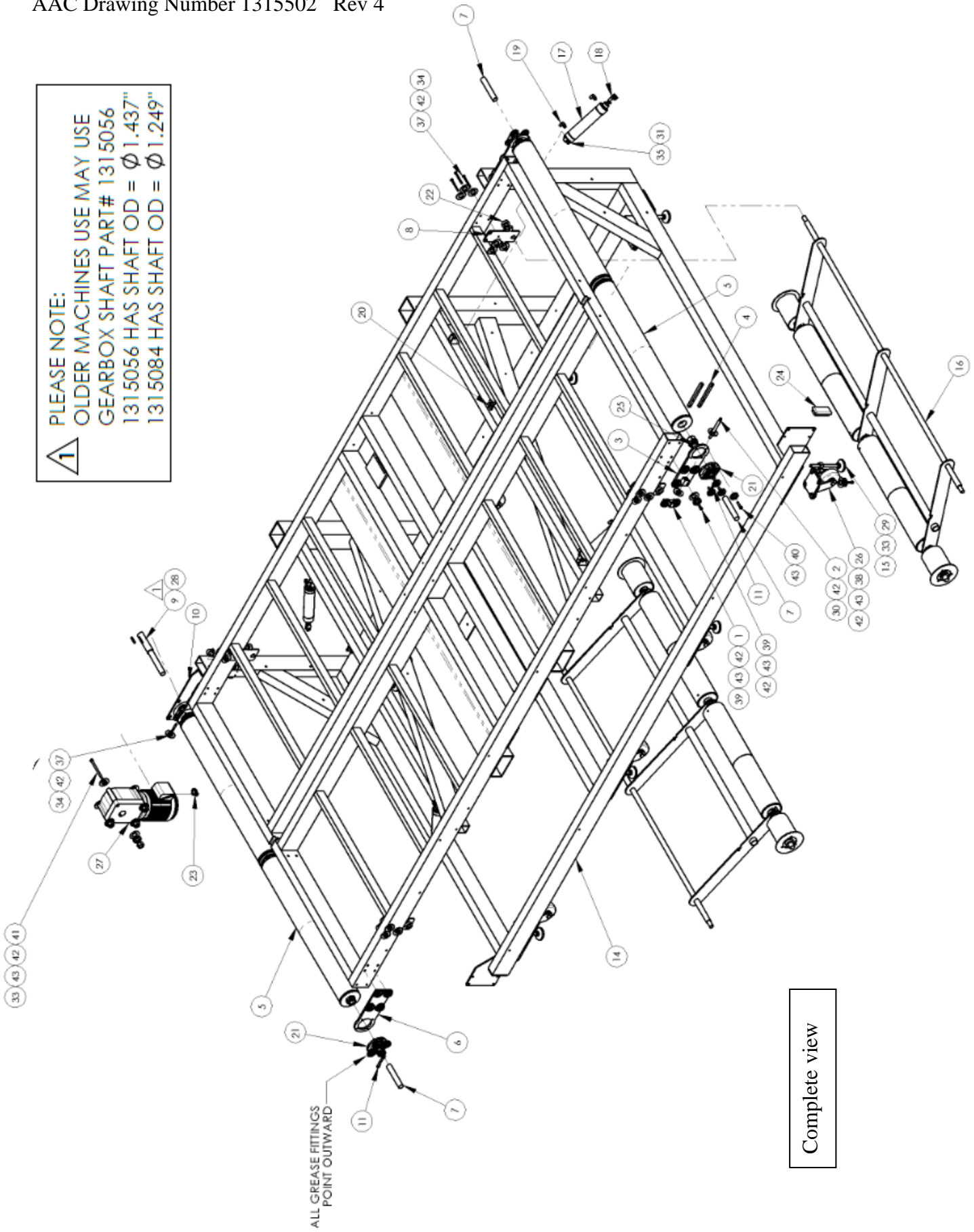

Complete view

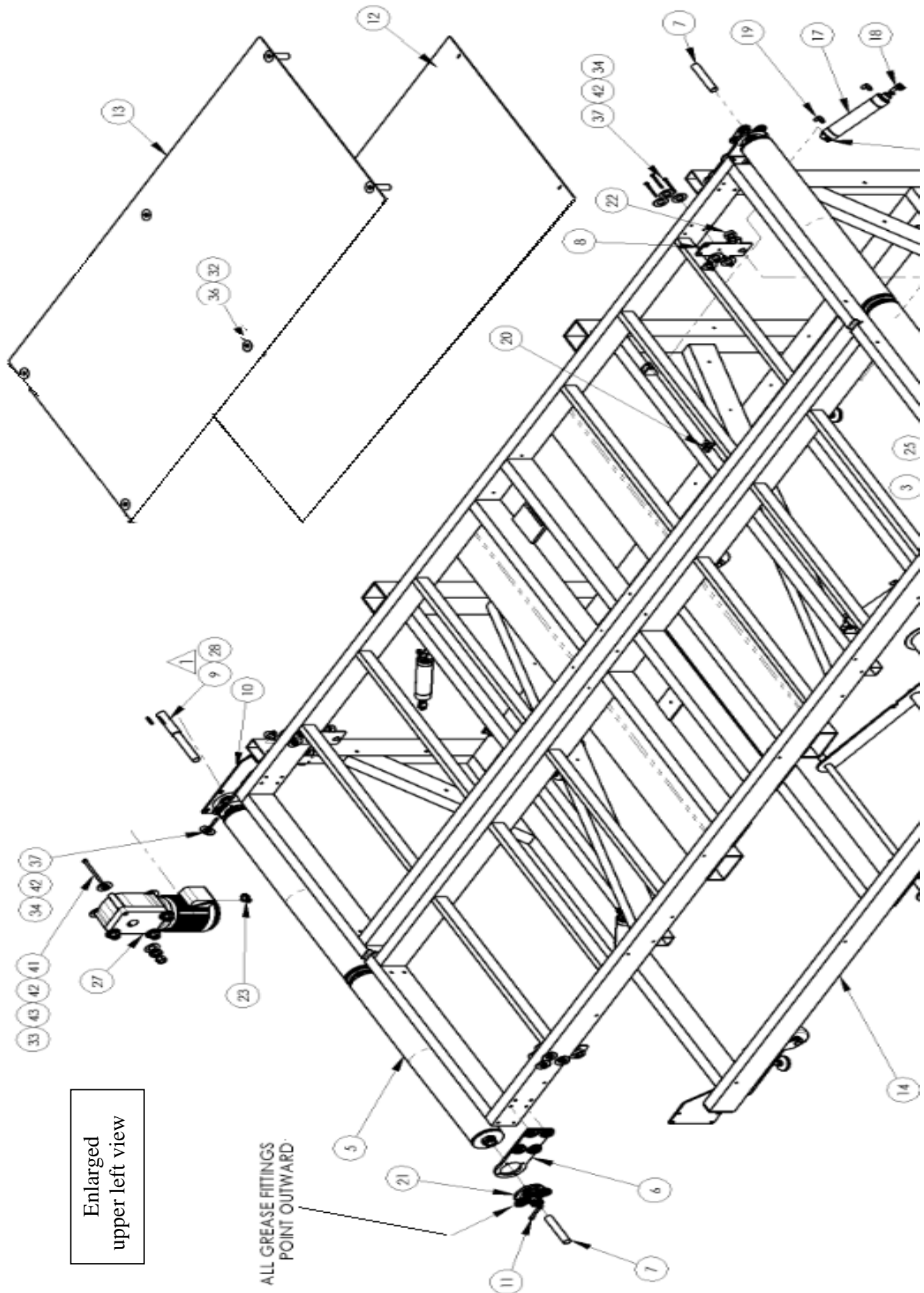

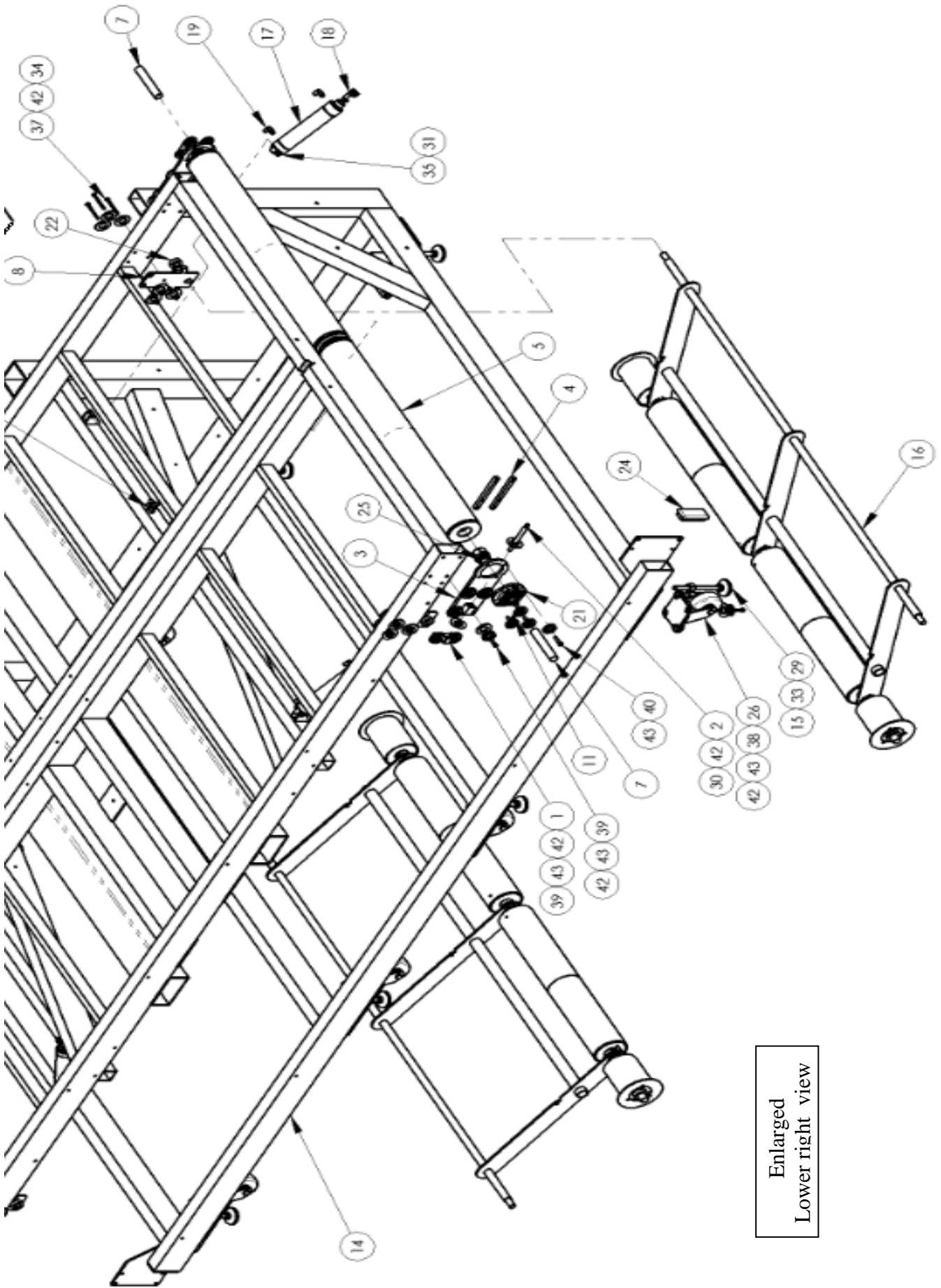

1315502 parts list

ITEM NO.	QTY	PART NUMBER	DESCRIPTION	ITEM NO.	QTY	PART NUMBER	DESCRIPTION
1	2	1315003	BLOCK, ROLLER TAKE-UP	25	4	MM6202240	TRANTORQUE,1" BORE
2	2	1315004	BOLT, BELT ADJUSTER	26	8	MM644001PHNTLB	CASTER, 4" SWIVEL W/BRAKE
3	2	1315007	PLATE, ADJUSTABLE BEARING	27	1	MMBF2SM35-015	GEARMOTOR, HOLLOW BORE
4	8	1315008	BAR, NUT	28	1	MMKEY1/4	KEYSTOCK,1/4 SQ.
5	2	1315010	ROLLER, CONVEYOR	29	8	MML-2	LEVELING PAD, 5/8-11
6	2	1315013	PLATE, BEARING MOUNT	30	2	NNE3/8-16	NUT, ELASTIC 3/8-16
7	3	1315052	SHAFT, IDLE ROLL	31	3	NNE5/16-18	NUT, ELASTIC LOCK, 5/16-18
8	4	1315054	MOUNT, TENSION ROLL	32	24	NNE8-32	NUT, ELASTIC LOCK, 8-32
9	1	1315084	SHAFT, MOTOR DRIVE	33	4	NNH5/16-18	5/16-18 HEX NUT
10	1	1315198	MOUNT, CONV. MOTOR	34	8	NNH5/8-11	5/8-11 HEX NUT
11	4	1315214	TABLE ADJ GAUGE	35	14	NNK1/4-20	KEP NUT, 1/4-20
12	4	1315263	PANEL, TOP	36	3	SSAS024080	3/8X1-1/4,5/16-18SHLDBOLT
13	4	1315369	PANEL, TOP UHMW	37	24	SSFC90032	#8-32 X 1/2 FLAT ALLEN
14	1	1315501	ASSY, FRAME	38	19	SSHC01192	1/4-20 X 3 HEX HEAD
15	8	1315661	ROD, THREADED, 5/8-11X7LG	39	32	SSHC10064	5/16-18 X 1" HEX HEAD
16	2	1315690	ASSY, TENSIONER ROLL, REVISED	40	20	SSHC10080	5/16-18 X 1-1/4 HEX HEAD
17	4	AAC316DXP	CYLINDER, AIR, 2" BORE	41	16	SSHC10096	5/16-18 X 1-1/2 HEX HEAD
18	4	AAFD2313	CLEVIS, AIR CYL 7/16-20	42	4	SSHC25384	3/8-16X6, HEX CAP
19	8	AAQME-4-4	ELBOW, MALE, Q, 1/4 TUBE, 1/4 NPT	43	33	WWFS1/4	WASHER FLAT, 1/4
20	4	AAQUT-4-4	QUICK UNION T 1/4X1/4	44	12	WWFS3/8	WASHER, FLAT, 3/8
21	4	BBMFC-16T	BEARING, 4B PILOTED FLANGE	45	52	WWFS5/16	WASHER, FLAT, 5/16
22	4	CCCL12F	CLAMP COLLAR- 3/4	46	4	WWL3/8	3/8 LW
23	1	K-235A	CONNECTOR, ROMEX, 3/4"	47	68	WWL5/16	5/16 LW
24	2	MM132-2X4	END CAP, RECT, BLACK	48	1400	ZZSH-310	TAPE, DOUBLE SIDED, 3/4"

1315575 Tape Roll Holder

AAC Drawing Number 1315575 Rev 1

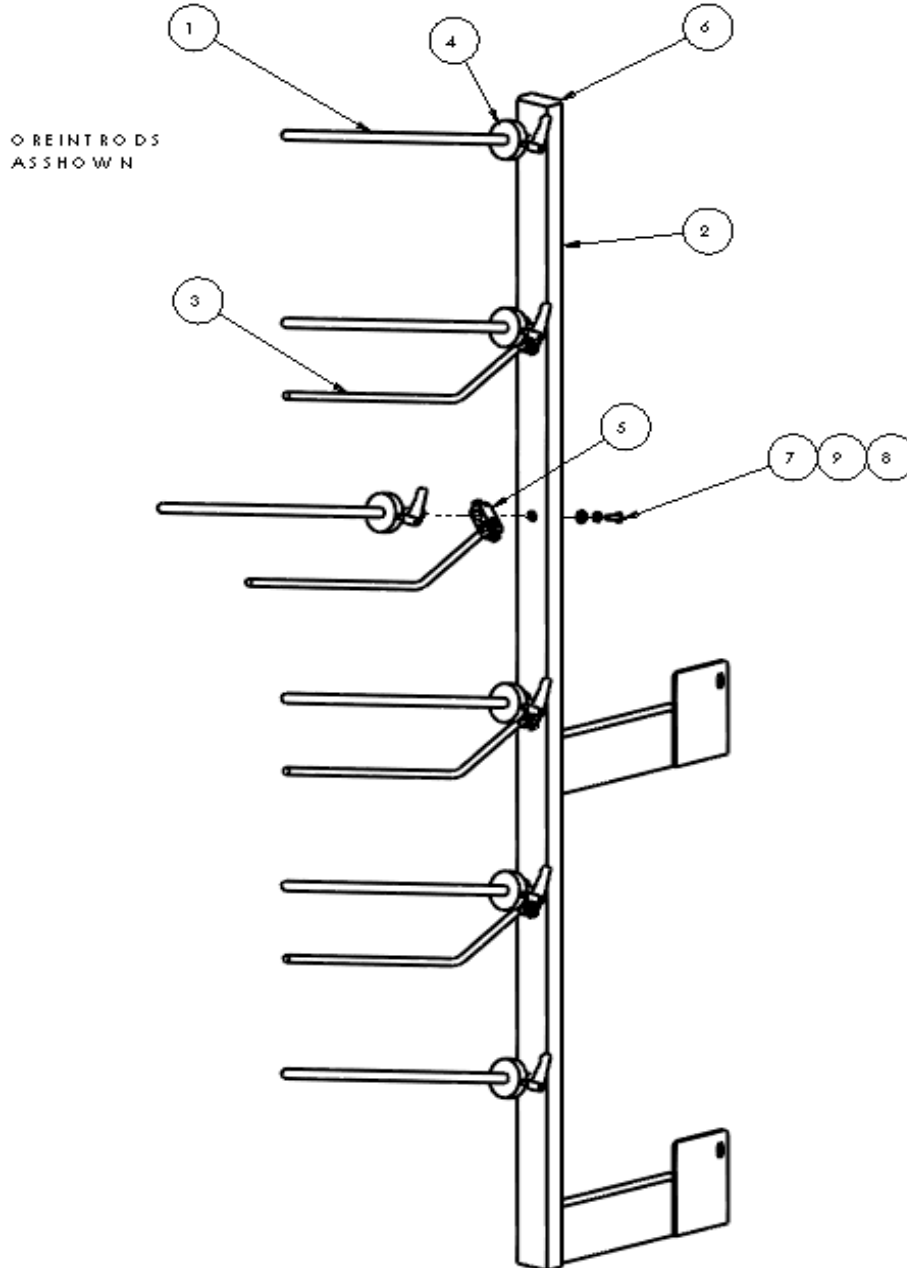

ITEM NO.	QTY	PART NUMBER	DESCRIPTION
1	6	1335-816	ROD,SS, 1/2 X 15.0 L
2	1	1315570	WELDMENT, ROLL HOLDER
3	4	1349127	ROD, SS, "L", 3/8, 6 X 12
4	6	A-4-032	EDGE GUIDE, 2" DIA, 1/2B
5	4	A-U	ROD CROSS BLOCK
6	1	MM132-1496	PLUG 1 X 2
7	6	SSHC01048	1/4-20 X 3/4 HEX CAP
8	6	WWFS1/4	WASHER,FLAT,SAE,1/4
9	6	WWL1/4	1/4 LW

1315595 Head Pusher Assembly

AAC Drawing Number 1315595 Rev 1

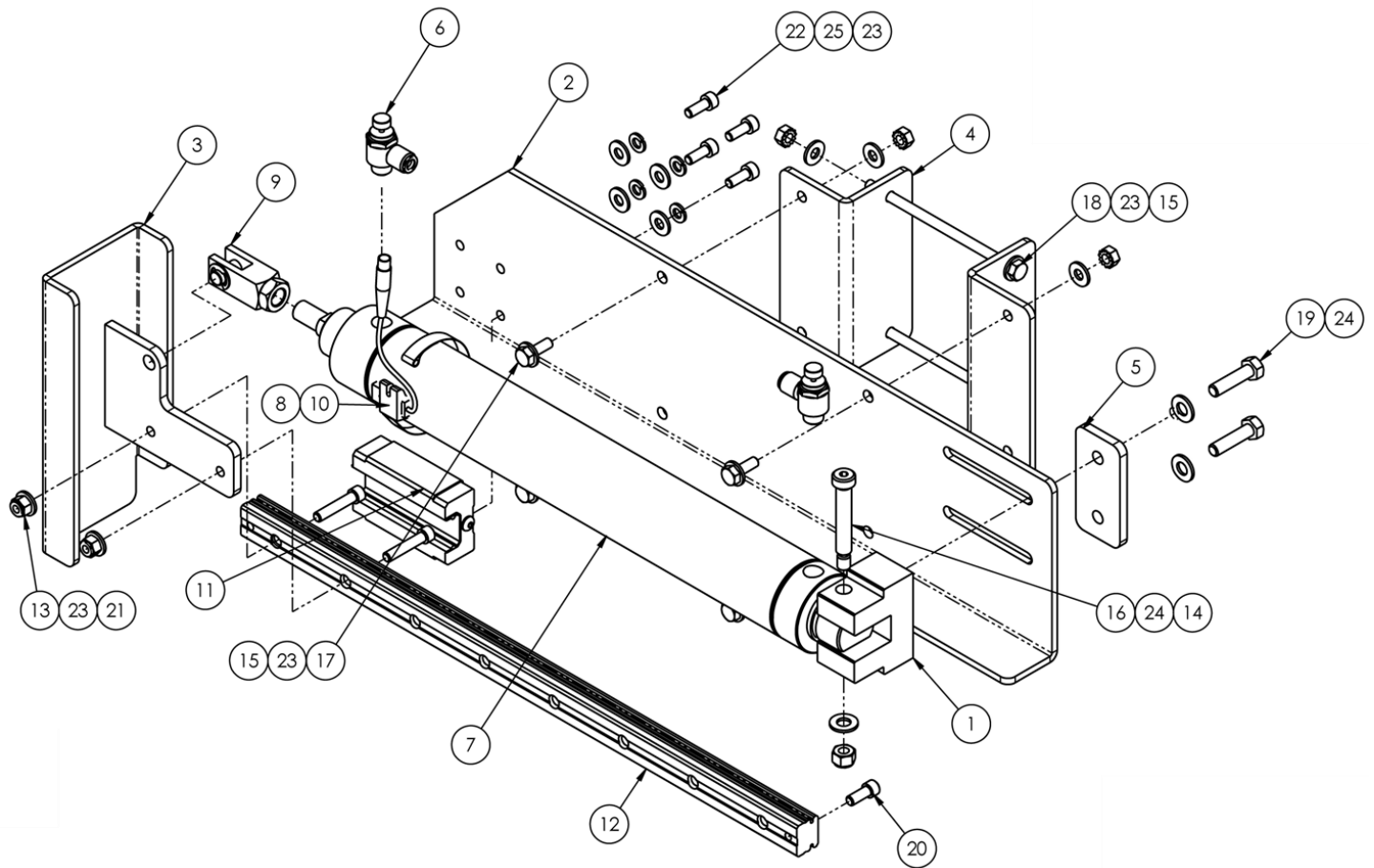

NO.	QTY	PART #	DESCRIPTION	NO.	QTY	PART #	DESCRIPTION
1	1	1315597	MOUNT, CYLINDER BASE	14	1	NNE5/16-18	NUT,ELASTIC LOCK,5/16-18
2	1	1315598	BASE, HEAD PUSHER	15	6	NNK1/4-20	KEP NUT, 1/4-20
3	1	1315600	WELDMENT, HEAD PUSHER RAM	16	1	SSAS024128	3/8 X 2 X 5/16-18 SHLD, BOLT
4	2	1315601	MOUNT, HEAD PUSHER BASE	17	4	SSHC01048	1/4-20 X 3/4 HEX HEAD
5	1	1315604	WASHER PLATE	18	2	SSHC01320	1/4-20 X 5 HEX HEAD
6	2	AA2201-07	FLOW CONTROL,1/4TX1/4NPT	19	2	SSHC10080	5/16-18 X 1-1/4 HEX HEAD
7	1	AACM3112DXP	CYLINDER,AIR,2" BORE	20	1	SSSC01040	1/4-20 X 5/8 SOC CAP
8	1	AAEHSKQ	SWITCH,HALL EFFECT BIMBA	21	2	SSSC01080	1/4-20 X 1-1/4 SOC CAP
9	1	AAFD2313	CLEVIS, AIR CYLINDER	22	4	SSSCM6X16	M6-1.0 X 16 SOC CAP
10	1	AAFD35875-14	BAND, CYLINDER,HSKQ HAL	23	18	WWFS1/4	WASHER FLAT, 1/4
11	1	MMAGH25CAN	LINEAR BEARING	24	3	WWFS5/16	WASHER, FLAT, 5/16
12	1	MMAGR25480M1	RAIL, MOD 480MM	25	4	WWL1/4	1/4 LW
13	2	NNE1/4-20	NUT,ELASTIC LOCK,1/4-20				

1315603 Sensor Bracket Assembly

AAC Drawing Number 1315603 Rev 1

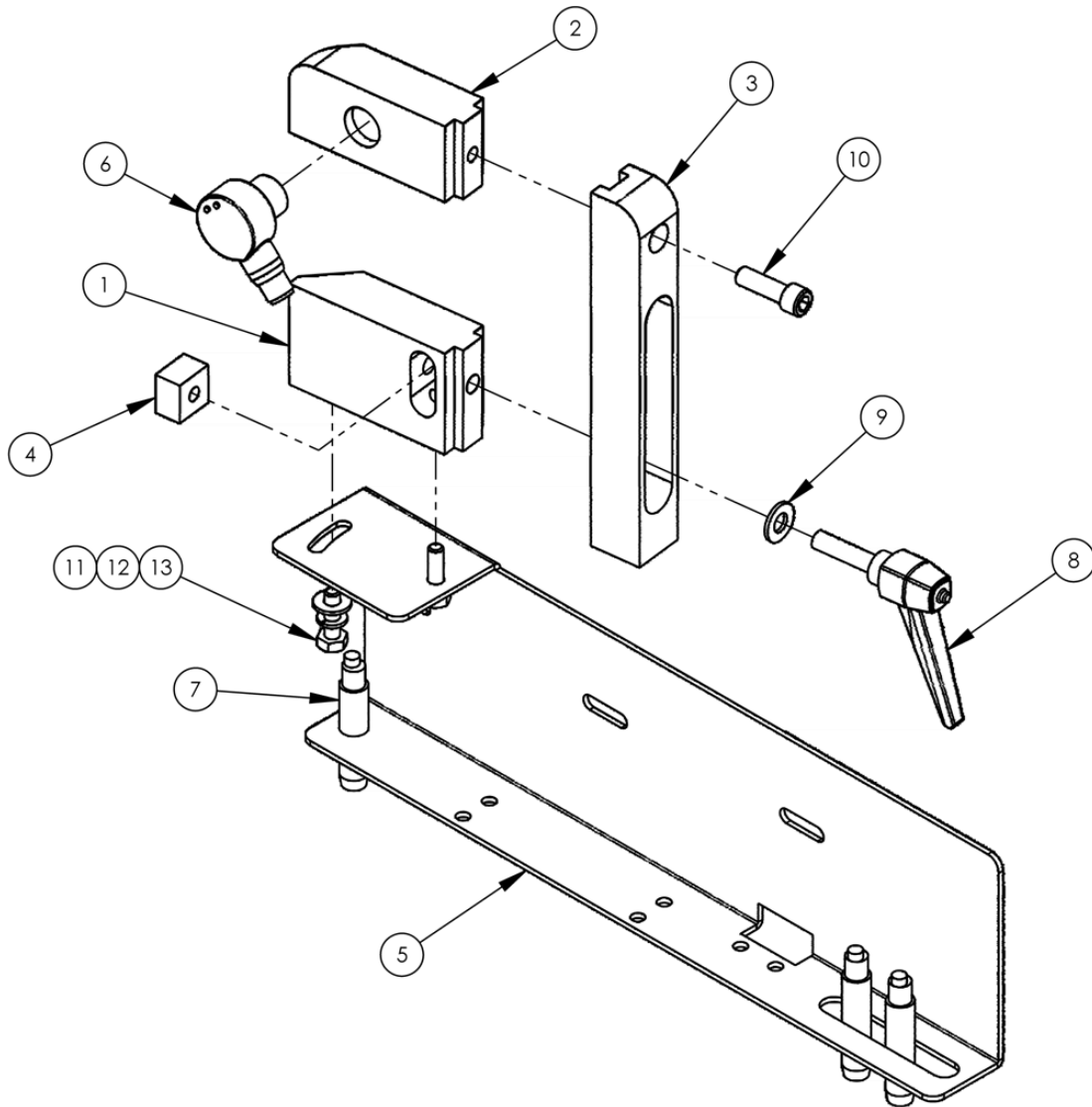

NO.	QTY	PART #	DESCRIPTION
1	1	1315015	BLOCK, EYE MOUNT
2	1	1315016	BLOCK, SENSOR
3	1	1315017	BRACKET, SENSOR MOUNT
4	1	1315020	BLOCK, NUT
5	1	1315605	BRACKET, SENSOR MTG
6	1	FFT18FF100Q	EYE, FIXED FIELD, 4IN
7	3	MMAM1-A0-4AM	PROX SWITCH, 10-30VDC, 12MM
8	1	TTH32426	HANDLE, THRD, 5/16-18X1-1/4
9	1	WWFS5/16	WASHER, FLAT, 5/16
10	1	SSSC10064	5/16-18 X 1 SOC CAP
11	2	WWFS1/4	WASHER FLAT, 1/4
12	2	WWL1/4	1/4 LW
13	2	SSHC01056	1/4-20 X 7/8 HEX HEAD

1315A-PD Pneumatic Diagram

AAC Drawing number 125606A Rev 0

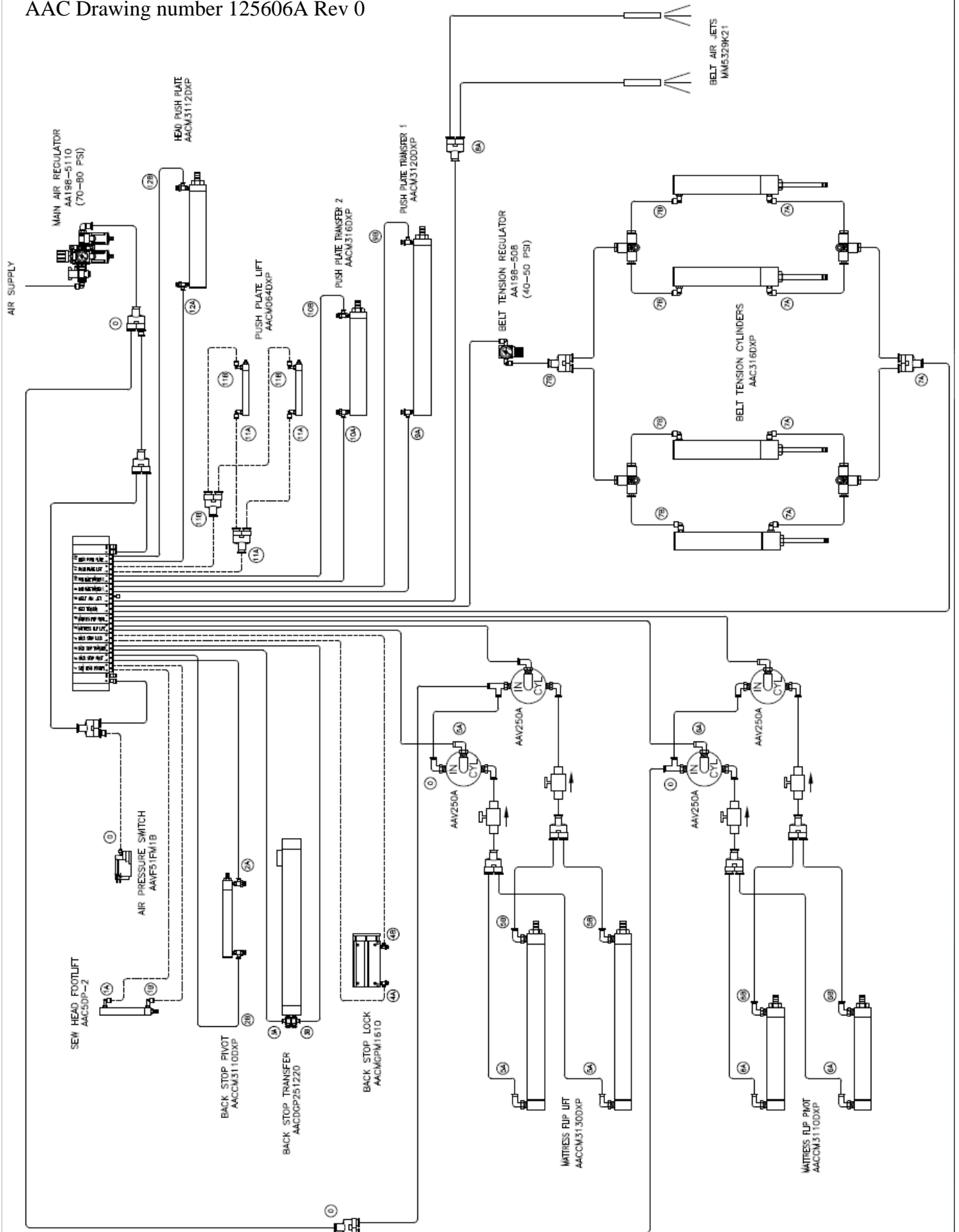

1315B-WD Wiring Diagram

AAC Drawing Number 125692D Rev 12

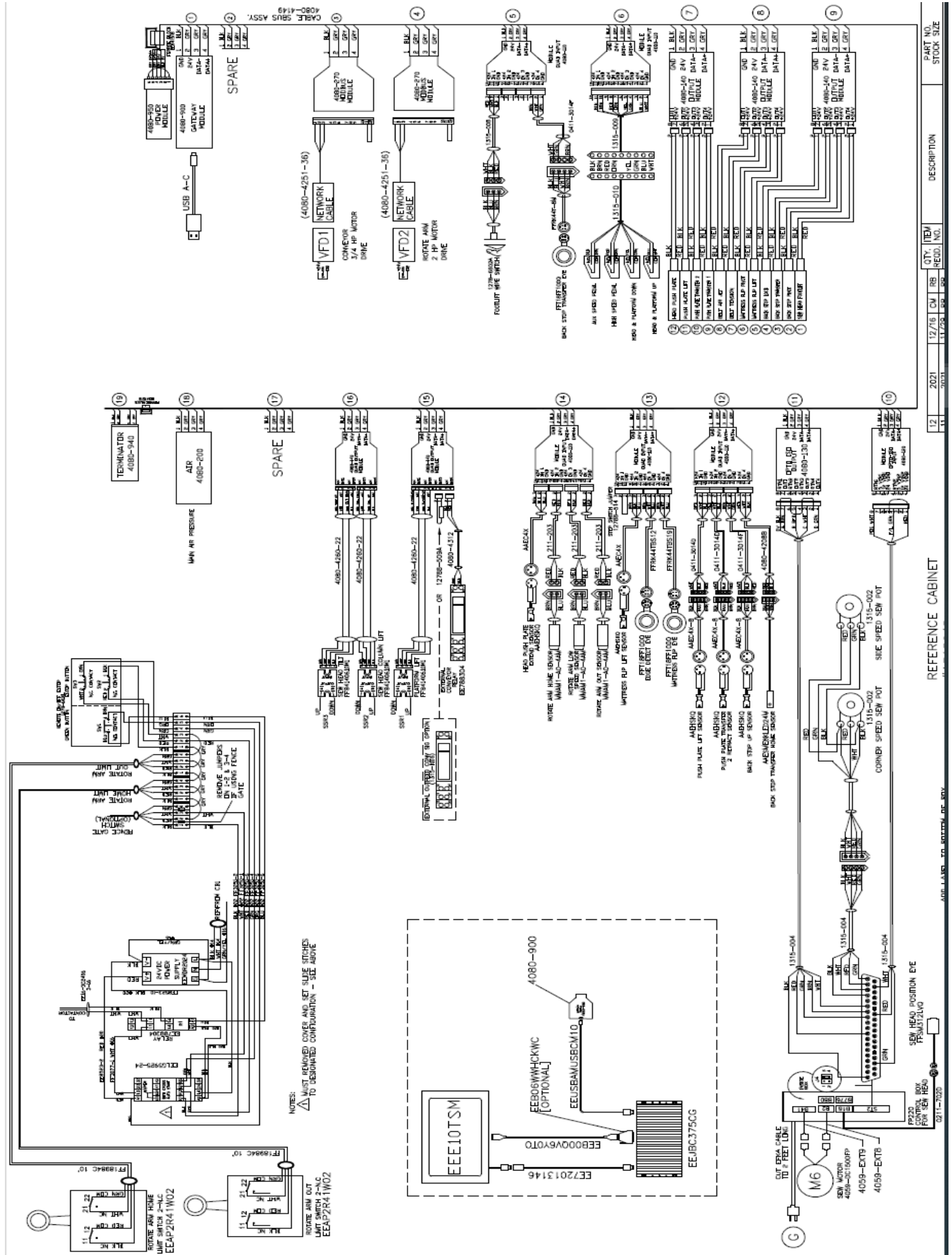

Atlanta Attachment Company (AAC) Statement of Warranty

Manufactured Products

Atlanta Attachment Company warrants manufactured products to be free from defects in material and workmanship for a period of eight hundred (800) hours of operation or one hundred (100) days whichever comes first. Atlanta Attachment Company warrants all electrical components of the Serial Bus System to be free from defects in material or workmanship for a period of thirty six (36) months.

Terms and Conditions:

- AAC Limited Warranty becomes effective on the date of shipment.
- AAC Warranty claims may be made by telephone, letter, fax or e-mail. All verbal claims must be confirmed in writing.
- AAC reserves the right to require the return of all claimed defective parts with a completed warranty claim form.
- AAC will, at its option, repair or replace the defective machine and parts upon return to AAC.
- AAC reserves the right to make the final decision on all warranty coverage questions.
- AAC warranty periods as stated are for eight hundred (800) hours or one hundred (100) days whichever comes first.
- AAC guarantees satisfactory operation of the machines on the basis of generally accepted industry standards, contingent upon proper application, installation and maintenance.
- AAC Limited Warranty may not be changed or modified and is not subject to any other warranty expressed or implied by any other agent, dealer, or distributor unless approved in writing by AAC in advance of any claim being filed.

What Is Covered

- Electrical components that are not included within the Serial Bus System that fail due to defects in material or workmanship, which are manufactured by AAC are covered for a period of eight hundred (800) hours.
- Mechanical parts or components that fail due to defects in material or workmanship, which are manufactured by AAC.
- Purchased items (sewing heads, motors, etc.) will be covered by the manufacturers (OEM) warranty.
- AAC will assist in the procurement and handling of the manufacturers (OEM) claim.

What Is Not Covered

- Parts that fail due to improper usage, lack of proper maintenance, lubrication and/or modification.
- Damages caused by; improper freight handling, accidents, fire and issues resulting from unauthorized service and/or personnel, improper electrical, plumbing connections.
- Normal wear of machine and parts such as Conveyor belts, "O" rings, gauge parts, cutters, needles, etc.
- Machine adjustments related to sewing applications and/or general machine operation.
- Charges for field service.
- Loss of time, potential revenue, and/or profits.
- Personal injury and/or property damage resulting from the operation of this equipment.

Declaración de Garantía

Productos Manufacturados

Atlanta Attachment Company garantiza que los productos de fabricación son libres de defectos de material y de mano de obra durante un periodo de ochocientos (800) horas de operación o cien (100) días cual llegue primero. Atlanta Attachment Company garantiza que todos los componentes del Serial bus son libres de defectos de material y de mano de obra durante un periodo de treinta y seis (36) meses.

Términos y Condiciones:

- La Garantía Limitada de AAC entra en efecto el día de transporte.
- Reclamos de la Garantía de AAC pueden ser realizados por teléfono, carta, fax o correo electrónico. Todo reclamo verbal tiene que ser confirmado vía escrito.
- AAC reserva el derecho para exigir el retorno de cada pieza defectuosa con un formulario de reclamo de garantía.
- AAC va, según su criterio, reparar o reemplazar las máquinas o piezas defectuosas devueltas para AAC.
- AAC reserva el derecho para tomar la decisión final sobre toda cuestión de garantía.
- Las garantías de AAC tiene una validez de ochocientas (800) horas o cien (100) días cual llega primero.
- AAC garantiza la operación satisfactoria de sus máquinas en base de las normas aceptadas de la industria siempre y cuando se instale use y mantenga de forma apropiada.
- La garantía de AAC no puede ser cambiado o modificado y no está sujeto a cualquier otra garantía implicado por otro agente o distribuidor menos al menos que sea autorizado por AAC antes de cualquier reclamo.

Lo Que Está Garantizado

- Componentes eléctricos que no están incluidos dentro del sistema Serial Bus que fallen por defectos de materiales o de fabricación que han sido manufacturados por AAC son garantizados por un periodo de ochocientas (800) horas.
- Componentes mecánicos que fallen por defectos de materiales o de fabricación que han sido manufacturados por AAC son garantizados por un periodo de ochocientas (800) horas.
- Componentes comprados (Motores, Cabezales,) son protegidos debajo de la garantía del fabricante.
- AAC asistirá con el manejo de todo reclamo de garantía bajo la garantía del fabricante.

Lo Que No Está Garantizado

- Falla de repuestos al raíz de uso incorrecto, falta de mantenimiento, lubricación o modificación.
- Daños ocurridos a raíz de mal transporte, accidentes, incendios o cualquier daño como resultado de servicio por personas no autorizados o instalaciones incorrectas de conexiones eléctricas o neumáticas.
- Desgaste normal de piezas como correas, anillos de goma, cuchillas, agujas, etc.
- Ajustes de la máquina en relación a las aplicaciones de costura y/o la operación en general de la máquina.
- Gastos de Reparaciones fuera de las instalaciones de AAC
- Pérdida de tiempo, ingresos potenciales, y/o ganancias.
- Daños personales y/o daños a la propiedad como resultado de la operación de este equipo.



Atlanta Attachment Company
362 Industrial Park Drive
Lawrenceville, GA 30046
770-963-7369
www.atlatt.com

Printed in the USA