



TYPICAL

GK321 *SERIES*

MULTI – NEEDLE CYLINDER BED
DOUBLE CHAIN STITCH MACHINE
INSTRUCTION BOOK / PARTS CATALOGUE

XI' AN TYPICAL INDUSTRIES CO., LTD.

CONTENTS

1. SPECIFICATIONS	1
2. NEEDLES AND THREADING THE MACHINE.....	2
3. MACHINE SPEED.....	7
4. LUBRICATION.....	7
5. SEWING MACHINE INSTALLATION.....	9
6. TIMING OF THE LOOPER TO THE NEEDLES.....	10
7. TIMING OF THE RETAINER LOOPER.....	11
8. ADJUSTING THE NEEDLE GUARD.....	12
9. ADJUSTING THE FEED DOG AND STITCH LENGTH.....	12
10. ADJUSTING THE PRESSER FOOT.....	14
11. ADJUSTING THE REAR PULLER DEVICE.....	15
12. ADJUSTING THE STITCH FORMATION.....	16
13. CLEANING THE MACHINE.....	17

Thank you for your purchasing our company's machine.

Read and study this instruction manual carefully before beginning any of the procedures and save it for later use.

1. This instruction manual describes adjustments and maintenance procedures on this machine.
2. Before starting the machine, check to make sure the pulley cover, safety cover, etc. are secured.
3. Before adjusting, cleaning, threading the machine or replacing the needle, be sure to turn off the power.
4. Never start the machine with no oil in the reservoir.
5. Refer to the parts list as well as this instruction manual before maintenance.
6. The contents described in this instruction manual are subject to change without notice.

1. SPECIFICATIONS

1 – 1 STITCH TYPE

401 double chainstitch machines

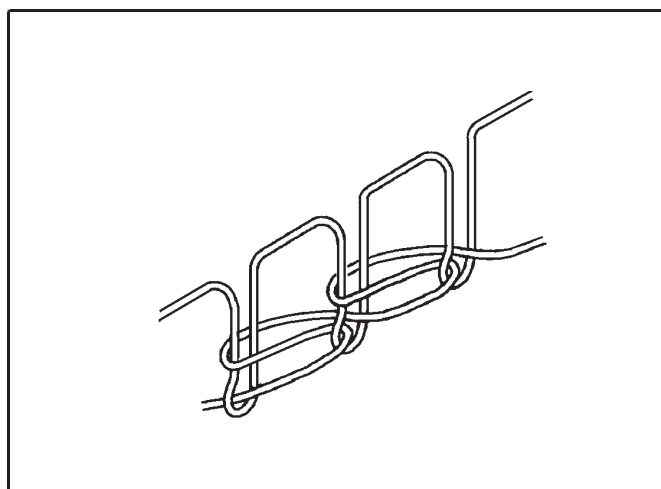

1 – 2 MODELS

Model		321 – 4	321 – 6	321 – 12
No. of needles		2 – 4	5 – 6	7 – 12
No. of threads	Needle thread	2 – 4	5 – 6	7 – 12
	Looper thread	2 – 4	5 – 6	7 – 12
Puller width		55mm	88mm	
Min. gauge width		4.76mm (3/16 inch)		
Max. gauge width		50mm	70mm (without thread trimmer) 76.2mm (with thread trimmer)	

1 - 3 DIAGRAMMATIC SKETCH OF THE SERIES

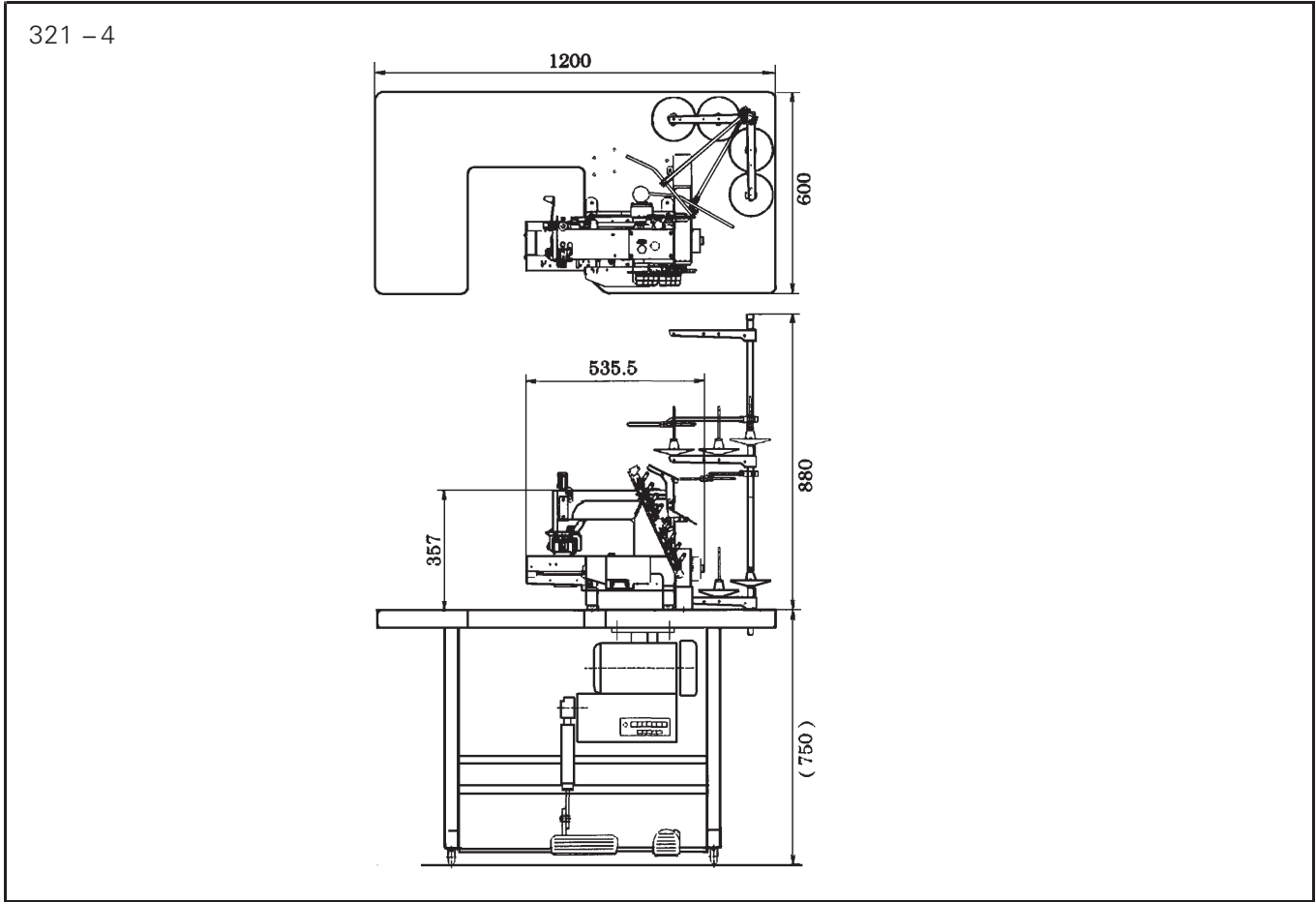

2. NEEDLE AND THREADING THE MACHINE

2 - 1 NEEDLES

DV x57 of Schmetz or organ

Select the proper needle for the fabric and thread to be used.

<Needle count comparison table>

Schmetz DVX57	Nm75	Nm80	Nm90	Nm100
Organ DVX57	#11	#12	#14	#16

2 - 2 REPLACING THE NEEDLE

When replacing the needle, check the needle carefully to see that the scarf is turned to the left (see the illustration.)

NOTE:

Be sure to turn off the machine before replacing the needle. A clutch motor continues running for a while after the machine is turned off. Therefore keep on pressing the pedal until the machine stops.

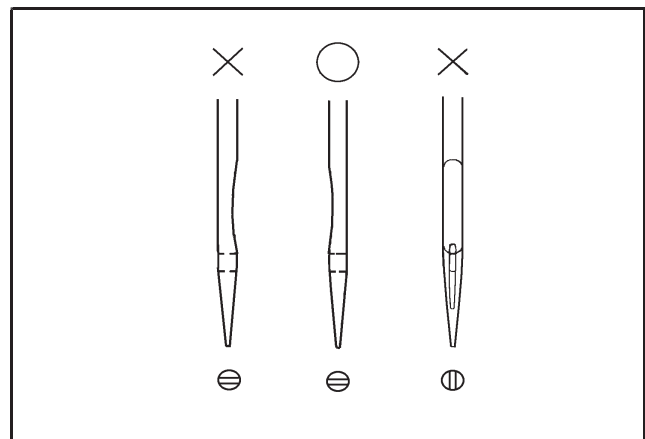

2 – 3 TO THREAD THE MACHINE

Thread the machine correctly by referring to the fig. Incorrect threading may cause skip stitching, thread breakage and uneven stitch formation. When threading the looper, tilt the looper holder toward the front of the machine using the looper drawing bar.

To tilt the looper toward the front

1. Bring needle bar A to the top of its stroke.
2. Pay out the needle thread from the spool by pressing a finger down on needle threads B.
3. Pull looper drawing bar knob C out to the left so that the looper holder is tilted toward the front of the machine.
4. After the machine is threaded, replace the looper by pressing looper holder D into the machine until it clicks.

Note:

The looper pops out of the machine as soon as knob C is pulled, so do not bring your fingers close to the looper.

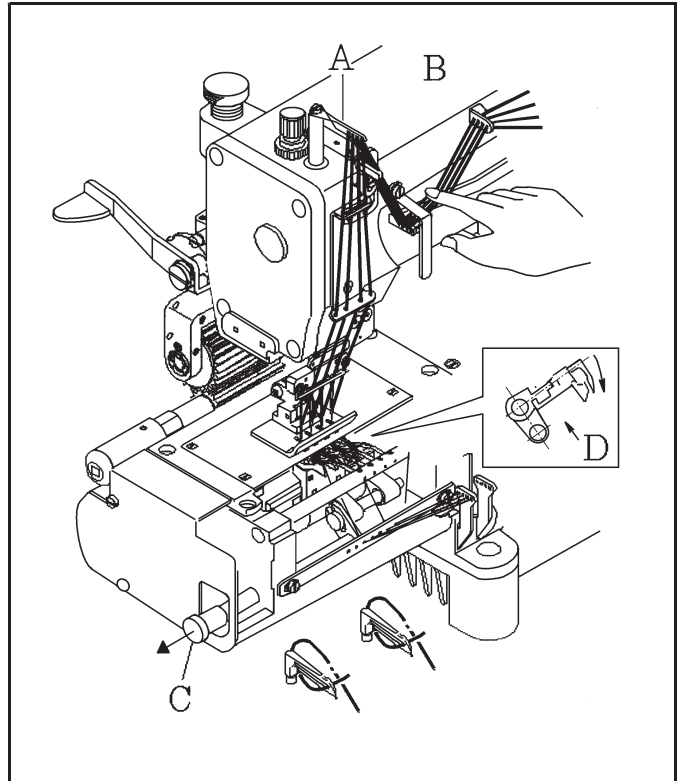

Threading diagram for 321 -4

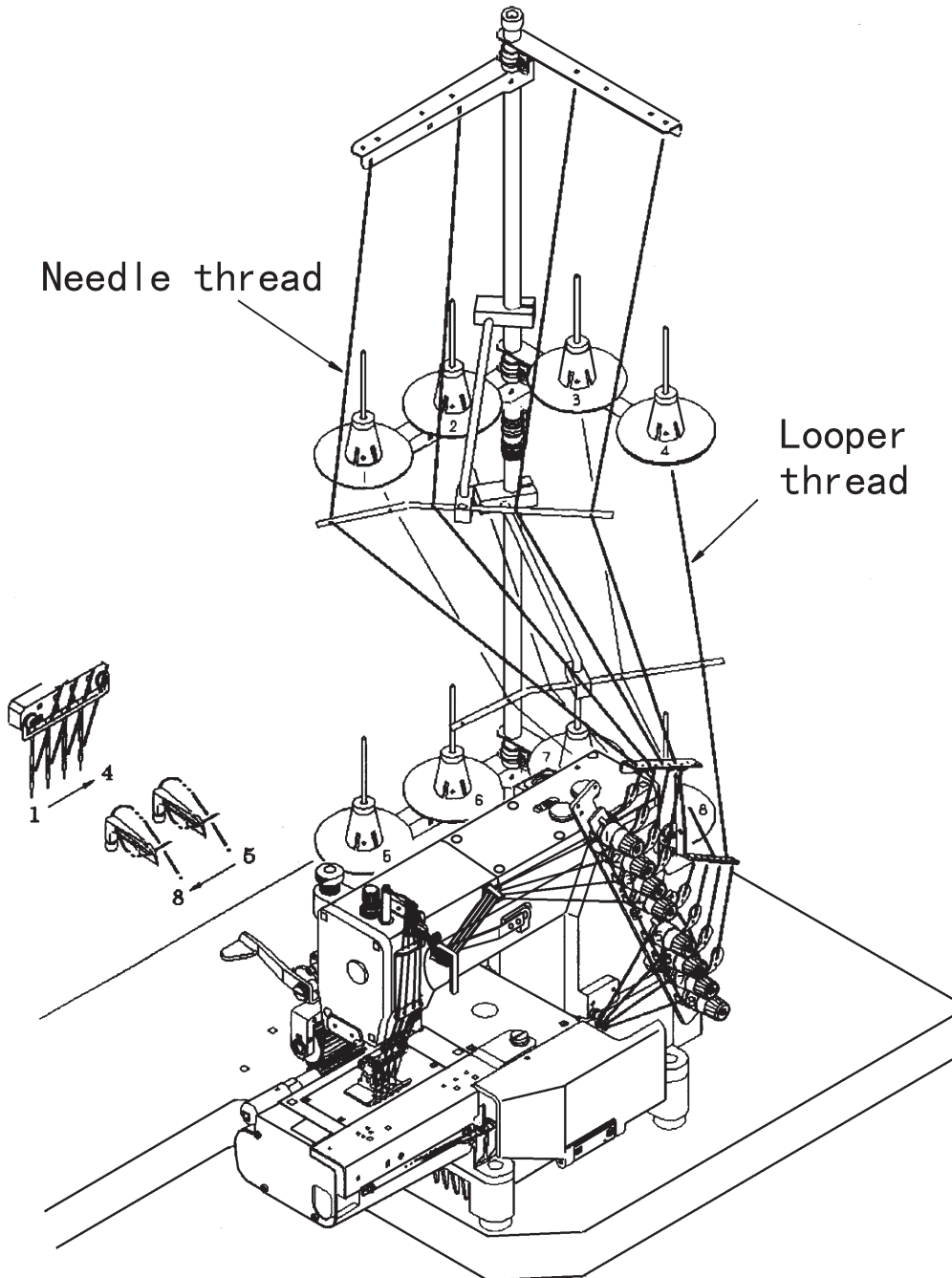

3. MACHINE SPEED

3 – 1 MACHINE SPEED AND DIRECTION IN WHICH THE MACHINE PULLEY RUNS

Refer to the table below for max. and standard speeds of the series.

To extend machine life, run the machine approximately 15 – 20% below the max. . speed for the first 200 hours of operation (approx. 1 month).

Then run the machine at the standard speed.

The machine pulley turns clockwise as seen from the end of the machine pulley.

Model	Max speed	Standard speed
321 – 4	4000	3500
321 – 12	3500	3000

3 – 2 MOTOR AND BELT

Motor: 3 – phase, 2 – pole, 400W clutch motor

Belt: M type V belt

Select the proper motor pulley according to the machine speed (refer to the motor pulley outer diameter on the table below).

Motor pulley outer diametermm	Machine speed SPM	
	50Hz	60Hz
60	2450	2950
70	2850	3450
80	3300	3900
90	3700	4400
100	4100	(4900)
110	4500	(5400)

Adjust the position of the motor by pressing the finger onto the middle of the belt so that 1 – 2cm deflection can be achieved

(see the illustration on the right).

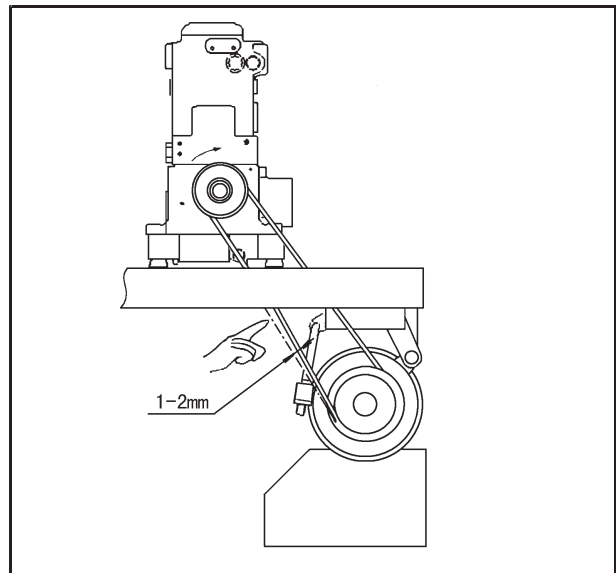

4. LUBRICATION

4 – 1 OIL

Use 18# industrial sewing machine oil

4 – 2 TO FILL THE MACHINE WITH OIL

Remove rubber plug A from the oil hole. Fill the machine with oil until the oil level is at the top line (see H in the illustration) on oil gauge C. After the first lubrication, add oil so that the oil level will be between H and L. After filling the machine with oil, run the machine to check the oil is splashing onto oil pot A.

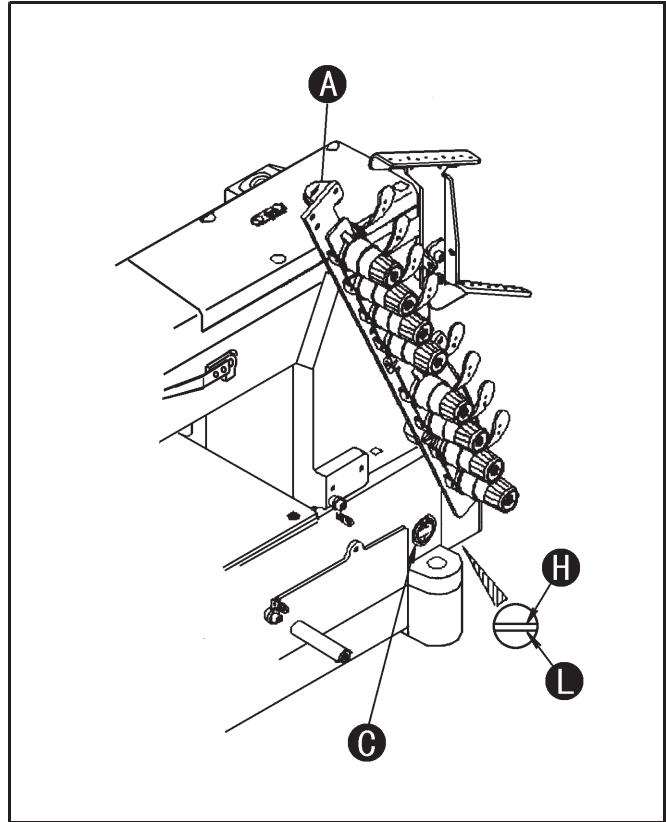

4 – 3 REPLACING THE OIL AND THE OIL ELEMENT

To extend machine life, be sure to replace the oil after the first 250 hours of operation.

To replace the oil, follow the procedures below.

1. Remove the V belt from the motor pulley and then remove the machine from the table.
2. Remove screw D and then drain the oil.
3. After draining the oil, be sure to tighten screw D.
4. Fill the machine with oil by referring to 4 – 2 shown above.

If element E is contaminated, proper oiling may not be performed. Clean the filter element every six months. If just a little or no oil flows out from the nozzle with the proper amount of oil in the machine, check the element. To do so, remove oil filter cap F.

Replacing the element if necessary.

Note:

When the oil filter cap is removed, the oil collected on the element drips. Be careful.

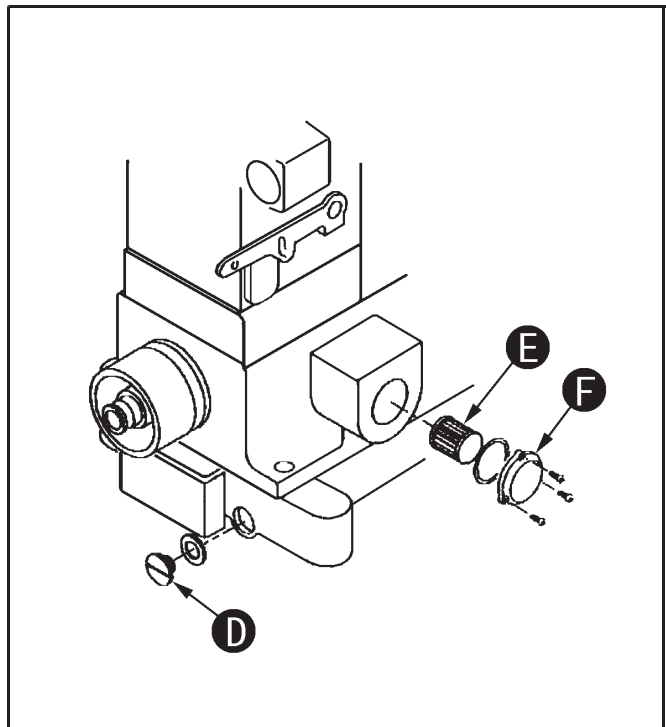

6. SINCRONIZACIÓN DEL LOOPER A LA AGUJA

6-1 COLOCACIÓN DEL LOOPER Y LOOPER ROCKE

Inserte el enlazador en el soporte del enlazador hasta que la parte inferior A del enlazador toque el balancín B del enlazador. Luego apriete el tornillo C.

Instale el looper de la máquina en un ángulo de 2° . La diferencia de nivel dentro de 15 mm es aproximadamente 0,5 mm. La holgura entre el looper y la aguja cuando la punta del enlazador pasa la bufanda en la aguja debe ser 0 a 0.1 mm

El ajuste se realiza aflojando los tornillos D y moviendo el balancín del looper hacia la izquierda o hacia la derecha según sea necesario.

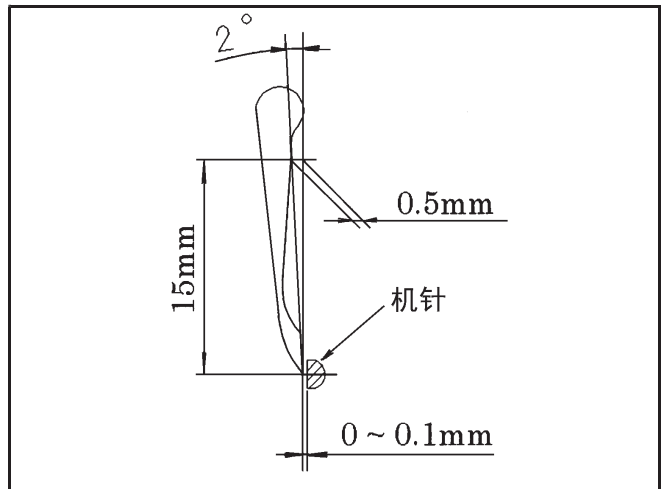
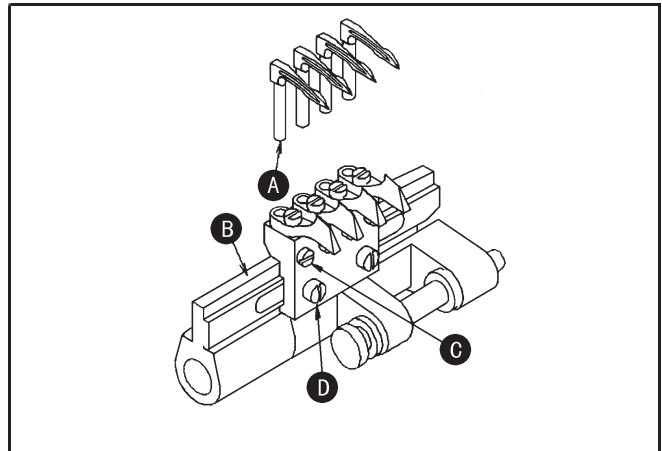

6-16 -2 MOVIMIENTO LOOPER DE IZQUIERDA A DERECHA

El tiempo del enlazador a la aguja es el siguiente.

Cuando la punta del garfio, moviéndose hacia la derecha, haya alcanzado el centro de la aguja, la punta del garfio debe estar 1,5 mm por encima de la parte superior del ojo de la aguja. Cuando la punta del garfio, moviéndose hacia la izquierda, haya alcanzado el centro de la aguja, la punta del garfio debe estar 2,3 mm sobre la parte superior del ojo de la aguja.

Para realizar este ajuste, retire primero la cubierta superior. Afloje el tornillo D. Luego mueva la excéntrica A. Para los estándares, la marca C se gira hacia arriba cuando la aguja está en la parte superior de su carrera (en la misma posición que la excéntrica B)

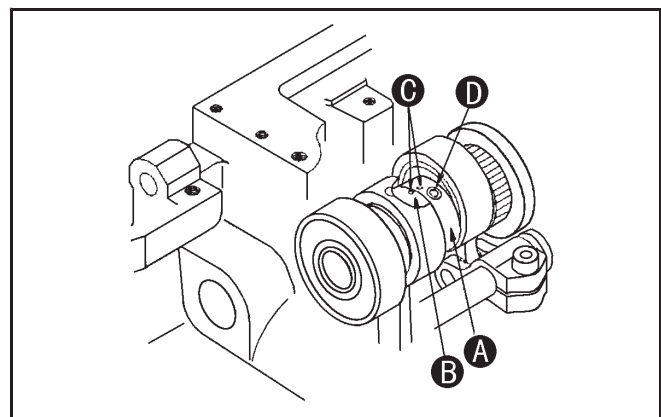
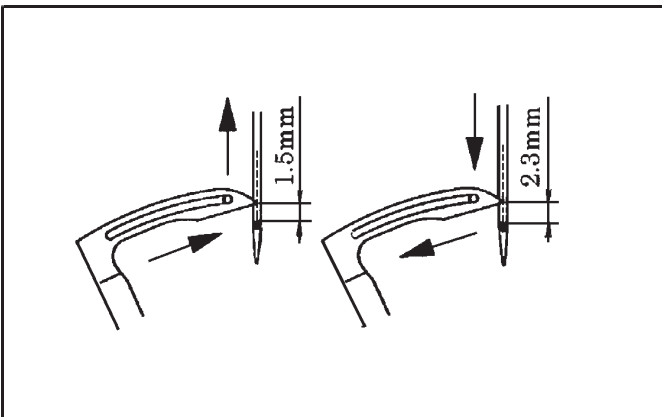

6 -3 DISTANCIA DE AJUSTE DEL LOOPER

Cuando la barra de agujas está en la parte inferior de su recorrido, debe haber una distancia de 3 mm desde la punta del enlazador hasta el centro de la barra de agujas.

El ajuste se realiza retirando la cubierta superior y aflojando el tornillo B de la palanca A..

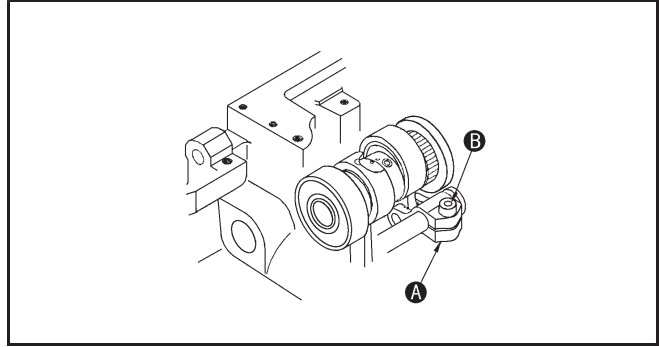
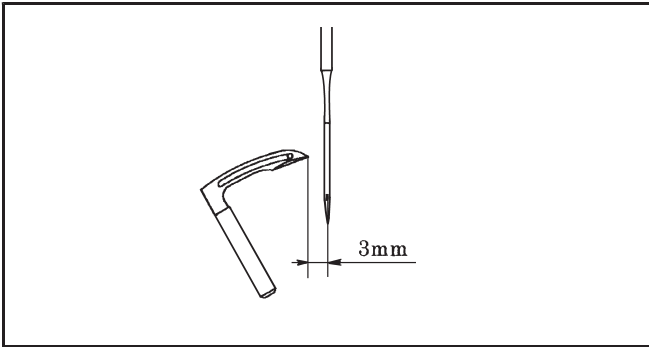

6 4E ALTURA BARRA DE AGUJAS

Cuando la barra de agujas esté en la parte superior de su carrera, retire el tapón A en la placa de cabeza, B con una llave hexagonal y luego mueva la barra de agujas hacia arriba o hacia abajo.

<fAltura de aguja estándar (distancia D)>

Recorrido	Modelo Estandar
34.5mm	14.5 - 14.9mm

Nota:

No afloje el tornillo de la guía de la barra de agujas C. Si este tornillo está flojo, asegúrese de que cada aguja caiga en el centro del orificio de caída de la aguja y luego vuelva a apretar el tornillo.

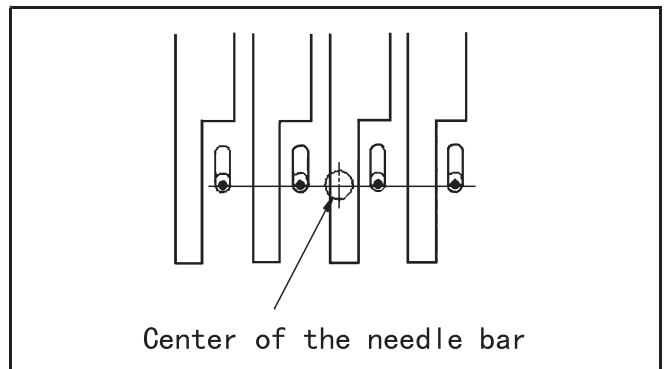
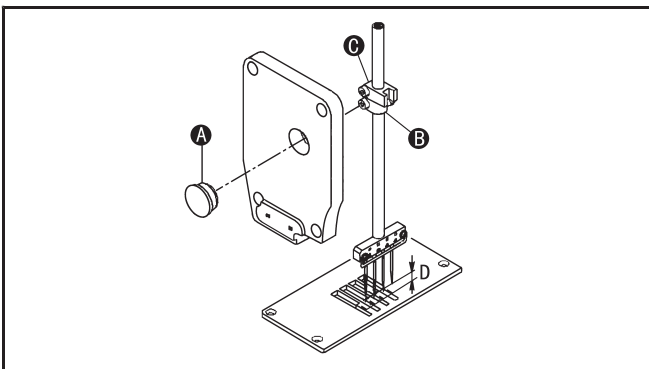

7. SINCRONIZACIÓN DEL LOOPER DE RETENCIÓN

7 -1 INSTALAR EL LOOPER DE RETENCION

Instale el gancho de retención A con su superficie plana hacia arriba. Debe haber una holgura de 0.6 -0.7 mm entre la aguja y la punta del garfio retenedor. Después de este ajuste, apriete el tornillo B.

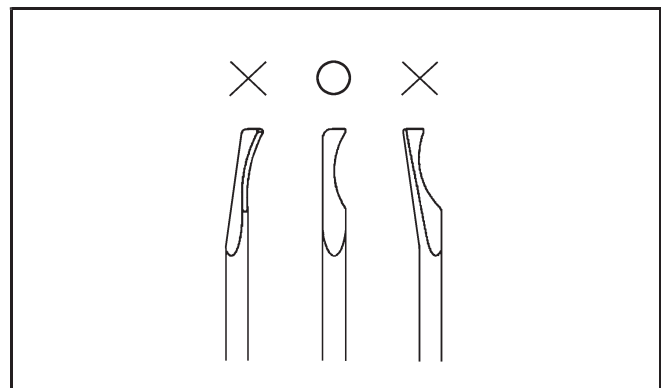
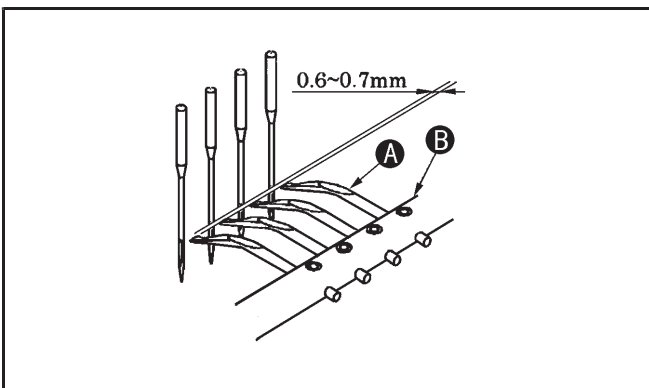

7 - 2 SINCRONIZACIÓN DEL ENLACE DE RETENCIÓN A LA AGUJAN

Cuando la punta de la aguja, descendiendo desde la parte superior a la inferior de su recorrido y entrando en el triángulo formado por el hilo del garfio, ha alcanzado aproximadamente 4,5 mm por debajo de la punta del garfio, el garfio de retención debe estar en el extremo derecho. final de su recorrido. Cuando el ojo de la persiana está cerca de la punta de la lanzadera de retención mientras la barra de aguja asciende hasta la parte superior de su recorrido, debe haber una separación de 0,3 mm entre el lado derecho de la lanzadera de retención y el de la lanzadera. el looper Cuando la barra de agujas está en la parte superior de su carrera, debe haber una separación de 0 mm entre el lado derecho del retenedor del garfio y el de la superficie superior (talón) de la hoja del garfio..

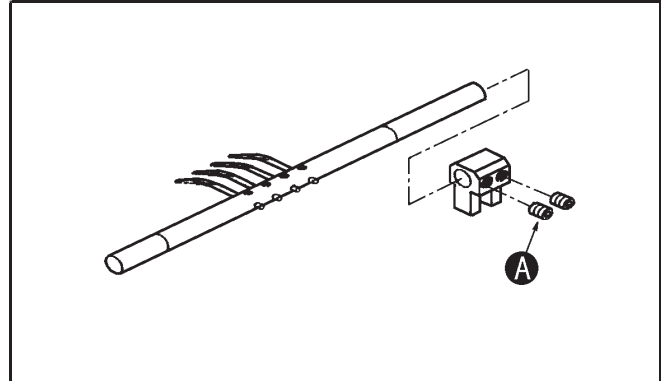
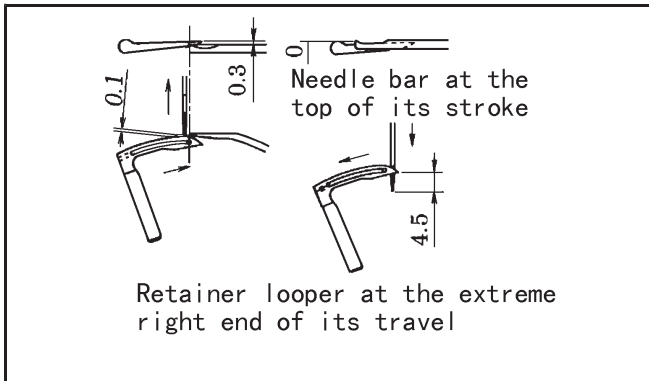

8. AJUSTE DEL PROTECTOR DE LA AGUJA

8 - 1 POSICIÓN DEL PROTECTOR DE LA AGUJA

Cuando el lado derecho de la aguja es el más cercano al protector de aguja A, debe haber una holgura de 0 - 0,1 mm entre ellos. El ajuste se realiza aflojando el tornillo B.

Nota:

Para un protector de aguja de tipo estándar, afloje el tornillo de fijación del garfio después de colocar el balancín del garfio, ajuste el protector de la aguja y luego apriete el tornillo B.

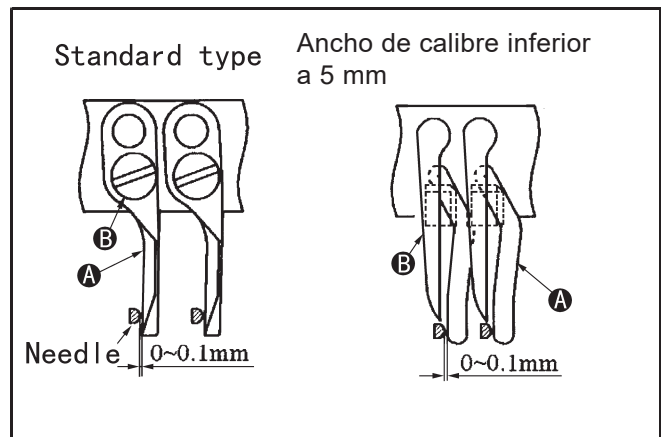

9. AJUSTE DEL TRANSPORTE Y LA LONGITUD DE LA PUNTADA

9 - 1 ALTURA E INCLINACIÓN DEL DIENTE DE ALIMENTACIÓN

Cuando la barra de agujas está en la parte superior de su carrera, los dientes del transportador deben estar 1 -1. 2 mm por encima de la superficie superior de la placa de la aguja. El ajuste se realiza aflojando el tornillo A. El ajuste de inclinación se realiza insertando una herramienta desde D y ajustando los tornillos B y C.

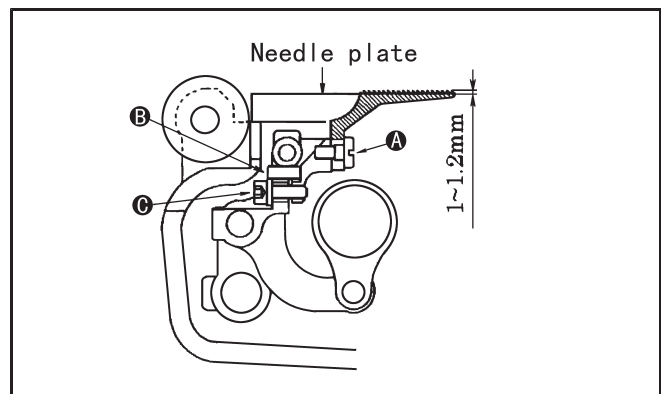

Después de marcar este ajuste, asegúrese de que el alimentador esté paralelo a la superficie superior de la placa de la aguja.

Nota:

Antes de ajustar la altura de los dientes de arrastre, incline el soporte del enlazador.

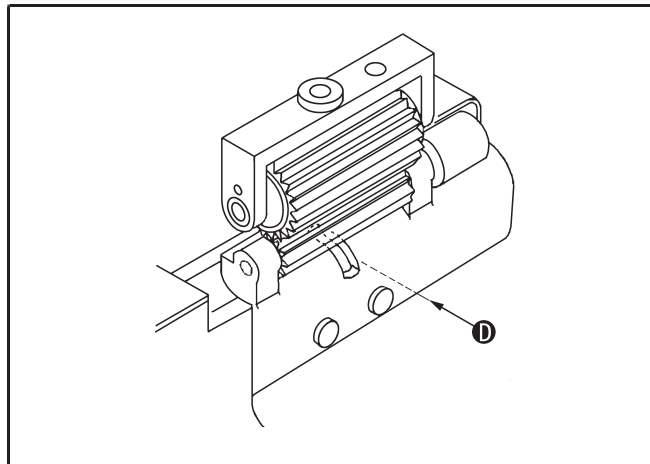

9 – 2 LARGO DE PUNTADA

El largo de la puntada se puede ajustar de 2 a 5 mm sin escalones.

La siguiente tabla muestra la longitud de la puntada con el número de puntadas dentro de 1 pulgada (25,4 mm) y 30 mm.

Stitch length (mm)	No. of stitches	
	Within 1"	Within 30mm
2	13	15
3	8.5	10
5	5	6

Para cambiar el laargo de puntadat

1. Presione el botón A ligeramente con la mano izquierda hasta que el extremo del botón A toque una parte interior y haga clic.
2. Con el pulsador A presionado, gire el volante con la mano derecha hasta que el pulsador se sumerja más en la profundidad.
3. Vuelva a pulsar con fuerza el pulsador. Luego gire la polea de la máquina para seleccionar la longitud de puntada según sea necesario
4. Alinee la longitud de puntada deseada con la marca de alineación, B. luego suelte la mano izquierda.

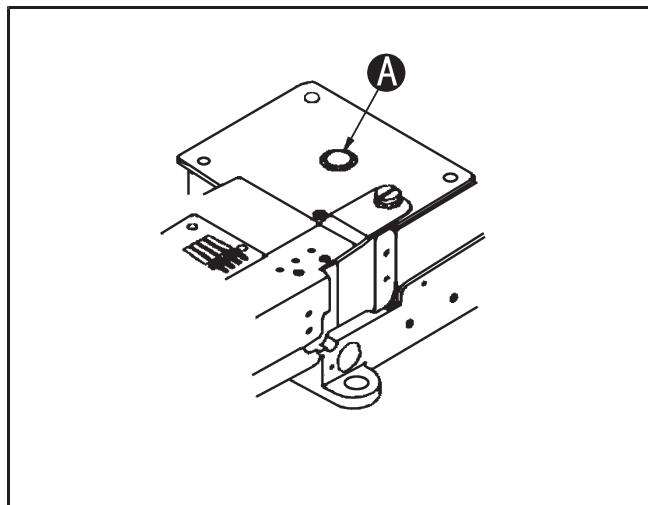

Nota:

Antes de cambiar la longitud de la puntada, asegúrese de apagar el motor.

10. ADJUSTING THE PRESSER FOOT

10 – 1 PRESSER FOOT PRESSURE

The presser foot pressure should be as light as possible, yet be sufficient to feed the fabric and produce uniform stitches. To increase the presser foot pressure, turn the adjusting knob clockwise (see the illustration).

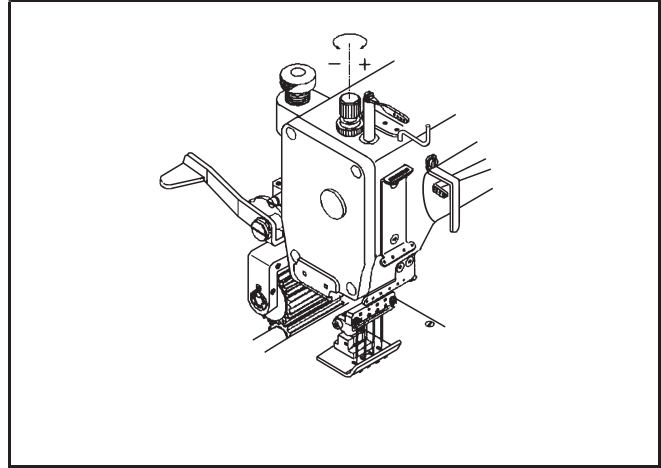

10 – 2 POSITION OF THE PRESSER FOOT AND FOOT LIFT

Fit the presser foot properly onto the presser bar.

Make sure the needle is centered left to right in the needle drop hole on the presser foot when the needle is descending. Adjustment is made by loosening screw A. There should be a clearance of 0.5 mm on both sides as shown in the illustration.

Adjustment is made by loosening nuts B.

Foot lift position stopper C with the presser foot approximately 10 mm above the top surface of the needle plate and then tighten nut D.

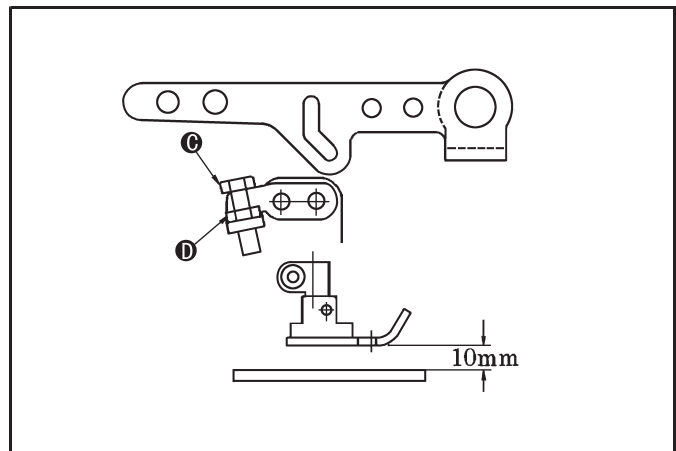
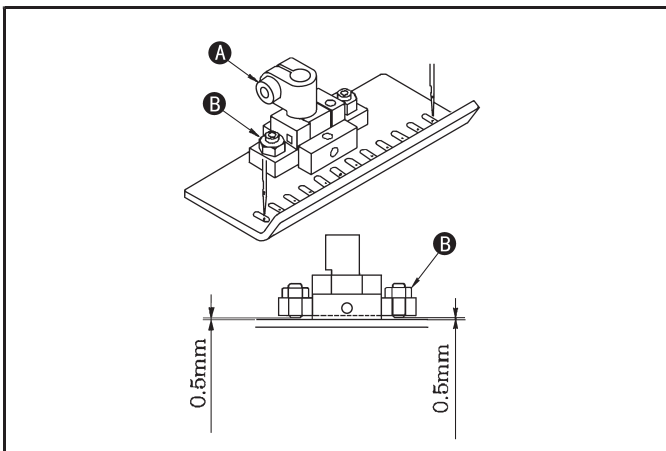

11. ADJUSTING THE REAR PULLEY DEVICE

11 - 1 MANUAL LEVER AND POSITION OF THE STOPPER

To position or remove the fabric, raise manual lever A. with the manual lever lowered, hold stopper B so that the clearance between the upper and lower pullers is 0.5 mm. Then tighten nut C.

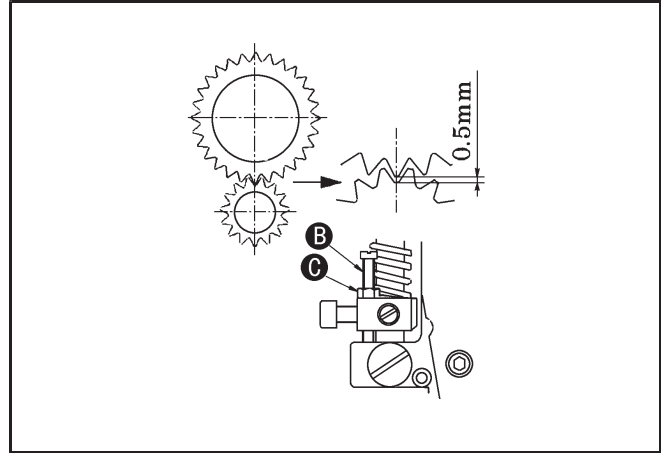

11 - 2 TO ADJUST THE PULLER PRESSURE

The puller pressure should be as light as possible, yet be sufficient to feed the fabric smoothly.

To increase the pressure, turn adjusting knob D clockwise. to decrease the pressure, turn adjusting knob D counterclockwise.

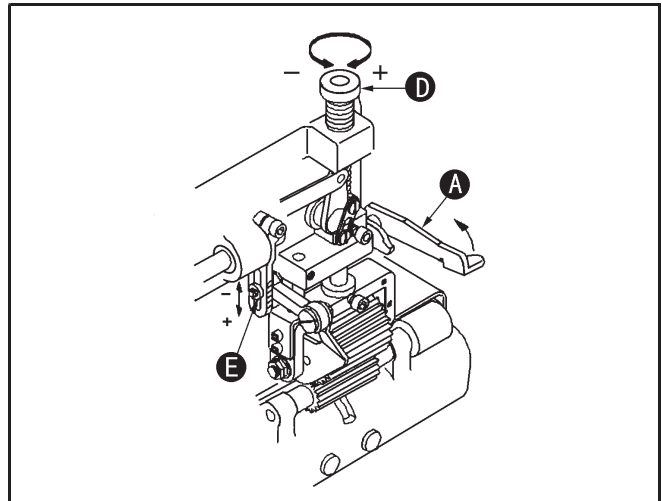

11 - 3 TO ADJUST THE FEEDING AMOUNT OF THE REAR PULLER

Adjust the feeding amount of the rear puller according to that of the feed dog.

To increase the amount, loosen nut E and move it down.

To decrease the amount, loosen nut E and move it up.

If the feeding amount is too large or small, remove rubber plug F, loosen screw G with a hex wrench and move screw G to the left or right.

To increase the amount, move screw G to the right.

To decrease the amount, move screw G to the left.

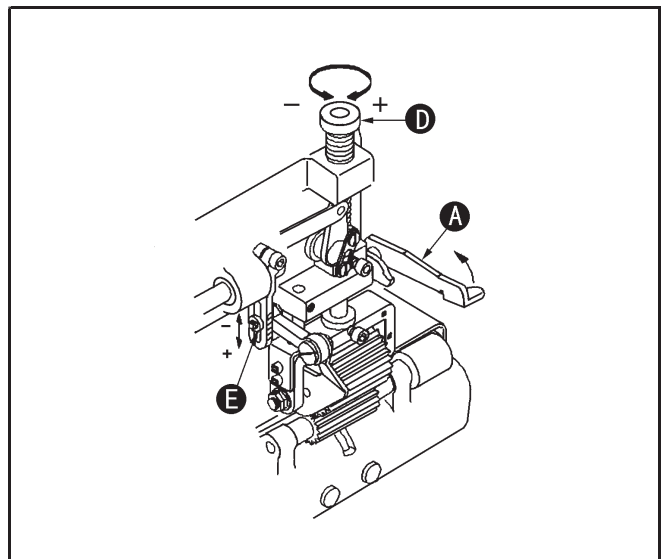

12. ADJUSTING THE STITCH FORMATION

12 – 1 THREAD TENSION ADJUSTMENT

Thread tension varies according to sewing conditions such as the fabric, thread and stitch length to be used.

Tension on the needle thread can be adjusted with nut A. Tension on the looper thread can be adjusted with nuts B. To increase the tension, turn the nuts clockwise.

Note:

The tension should be as light as possible, yet be sufficient to produce uniform stitches.

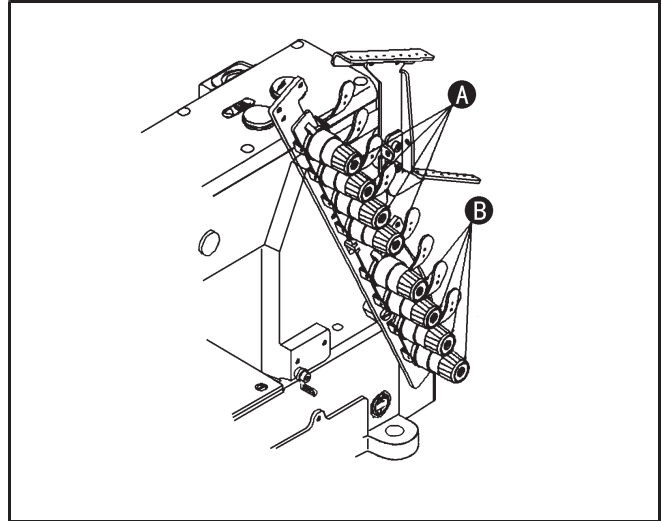

12 – 2 POSITION OF THE NEEDLE THREAD EYELET

Position needle thread eyelet C so that the distance from the center of the screw to the eyes of C is approximately 40 mm.

Note:

Adjust the needle thread eyelet according to the thread to be used. To tighten the needle thread, raise the needle thread eyelet.

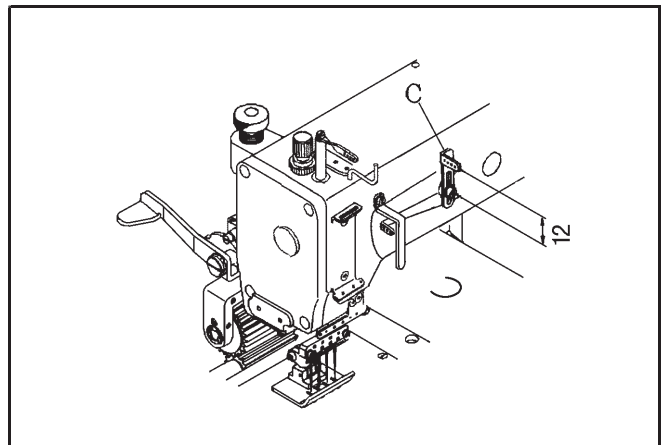

12 – 3 TO ADJUST THE NEEDLE THREAD GUARD

With the needle bar at the bottom of its stroke, the centers of the eyes on needle bar eyelet B should be level and parallel with the top surface of needle thread guard A.

Note:

Raising needle thread guard A increases the size of the needle thread loop.

Lowering needle thread guard A decreases the size of the needle thread loop.

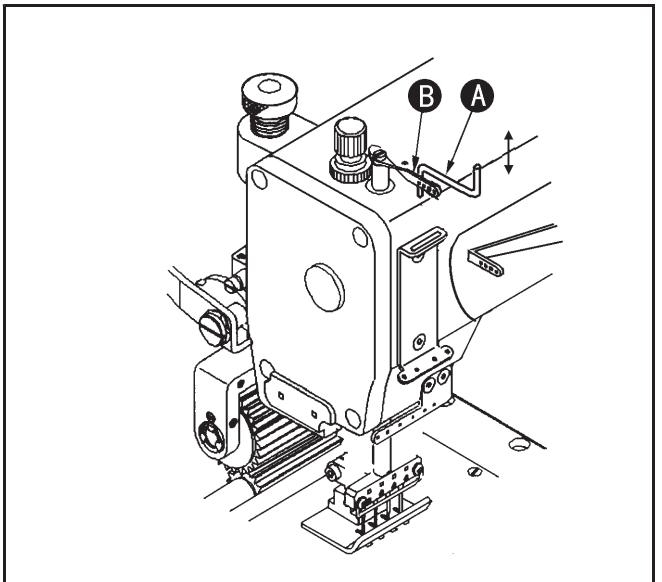

12 – 4 POSITION AND TIMING OF THE LOOPER THREAD TAKE – UP EYELET

When the point of the needle is level with the top surface of the looper while the needle bar is descending from the top to bottom of its stroke on the back side of the looper, the looper thread take – up bar should start ascending.

Adjusting is made by loosening the screw and aligning the mark on the eccentric with that on the main shaft. Then the looper thread take – up bar is at the bottom of its stroke, adjust distance A from the eyes on the thread eyelet to the looper thread take – up bar by referring to the table below.

Thread type	Distance A
polyester	8mm
Spun	10mm
Woolly	15mm

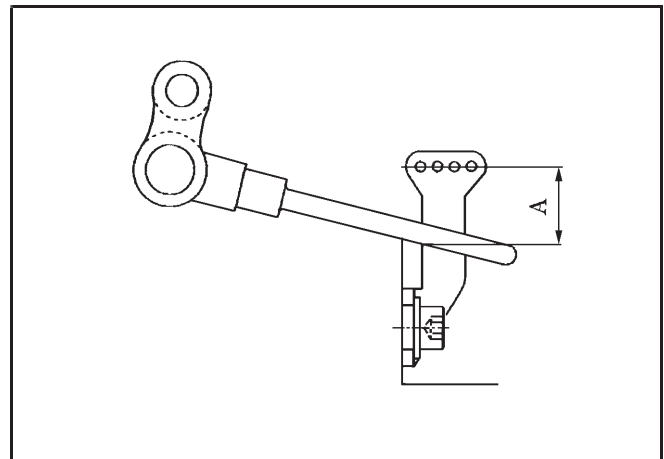
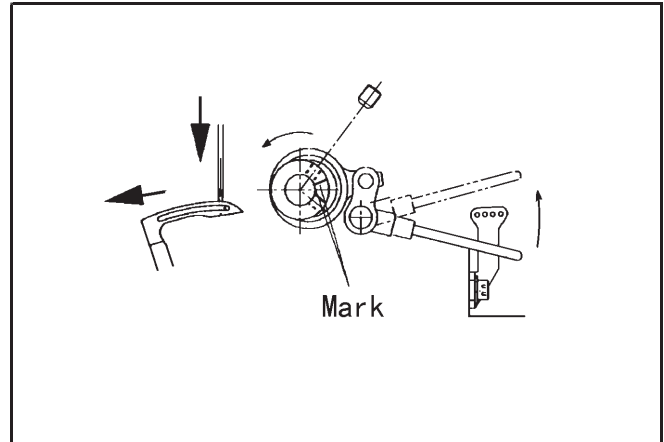

13. CLEANING THE MACHINE

At the end of each day, remove the presser foot and the needle plate and then clean the slots of the needle plate and the area around the feed dogs.

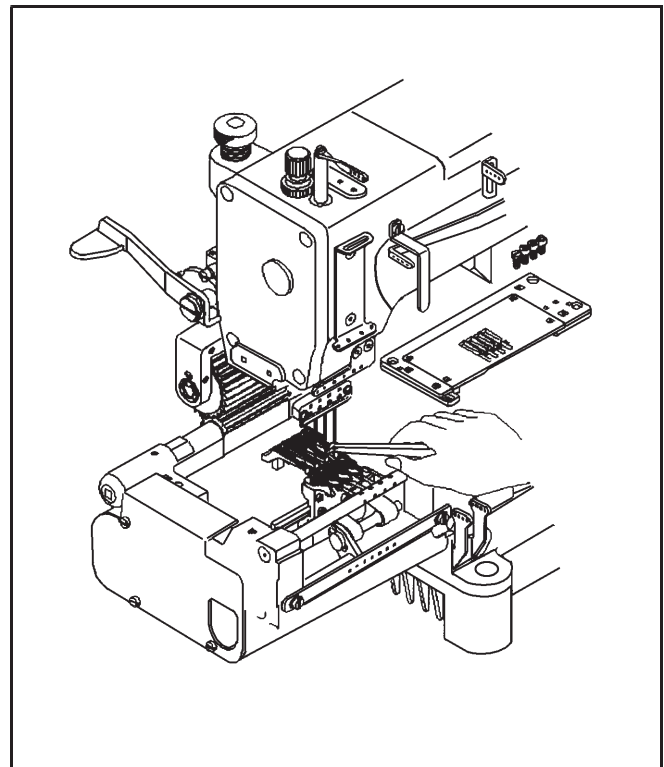

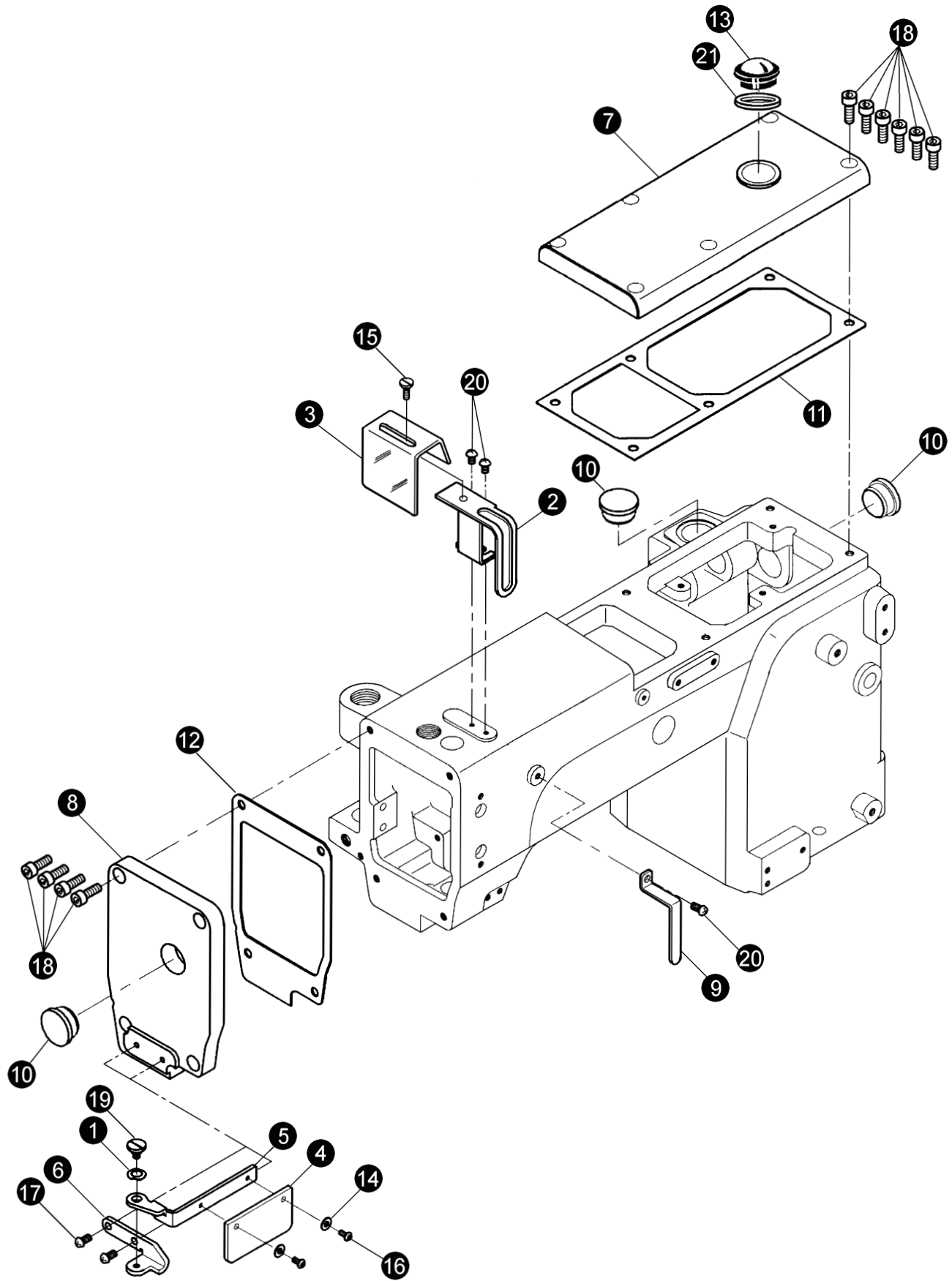

1. FRAME ASSEMBLY (1)

No.	Ref. No.	Description	Qt.
1	S150643002	Washer	1
2	197120001	Needle bar guard	1
3	197120002	Needle bar cover	1
4	197130001	Eye guard	1
5	197130002	Eye guard support	1
6	197130003	Eye guard bracket	1
7	197140001	Top cover	1
8	197100001	Face plate	1
9	197100003	Thread take-up lever guard	1
10	197100004	Rubber plug	2
11	197100005	Gasket	1
12	197100002	Gasket	1
13	043120002	Oil sight window	1
14	008230003	Washer 4	2
15	197120003	Screw	1
16	S120203033	Screw M4 x 6	2
17	B62400812	Screw M4 x 8	2
18	S150220004	Screw M5 x 14	10
19	197130004	Screw	1
20	B62400812	Screw M4 x 8	1
21	S150656025	O-type ring 25.8 x 1.8	1

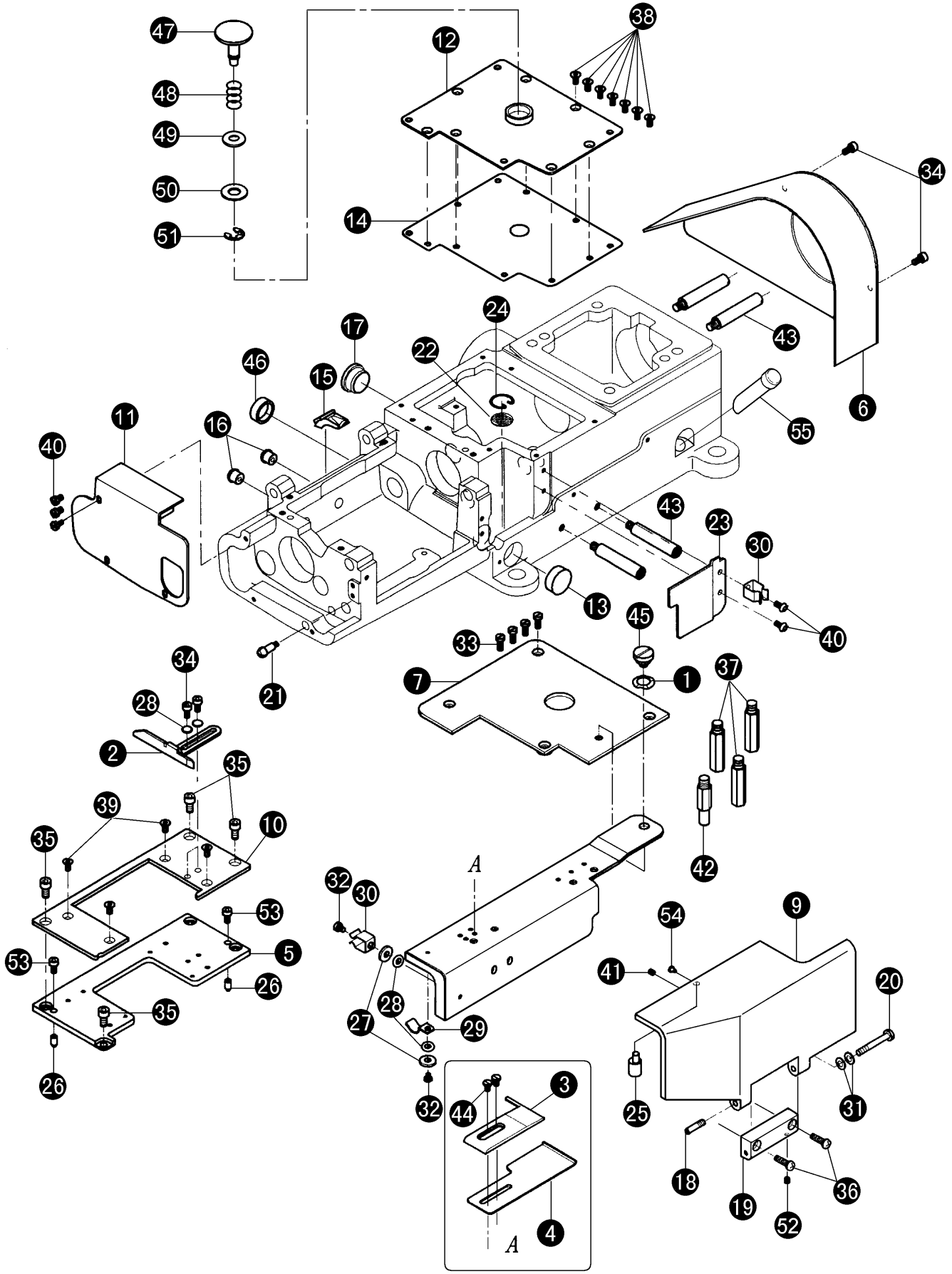

2. FRAME ASSEMBLY (2)

No.	Ref. No.	Description	Qt.
1	197150002	Washer12	1
2	197100006	Material guide	1
3	197100007	Tape guide, left	1
4	197100008	Tape guide, right	1
5	197100009	Needle plate support bracket	1
6	197F01001	Pulley cover	1
7	197151000	Upper cover	1
8	197152001	Front plate cover	1
9	197160001	Front cover	1
10	197100011	Cover	1
11	197100012	Left cover	1
12	197171000	Upper cover	1
13	197100013	Rubber plug	4
14	197100014	Gasket	1
15	197100015	Rubber plug	1
16	197100025	Rubber plug	2
17	197100004	Rubber plug	1
18	197160003	Screw	1
19	110150002	Hinge	1
20	197160002	Screw	1
21	197100017	Pin	1
22	110300005	Oil filter screen	1
23	197100018	Oil fence	1
24	110300006	Clamp	1
25	197160004	Pin	1
26	182100045	Pin	2
27	110200005	Washer	2
28	008230003	Washer 4	3
29	197152002	Spring	1
30	197100016	Spring	2
31	S150643001	Washer 5	2
32	S120203031	Screw M4 x 5	2
33	B62401012	Screw M4 x 10	4
34	S150220041	Screw	2
35	S150220007	Screw M5 x 10	4
36	S150237004	Screw M4 x 12	2
37	197100020	Support pole	3
38	S120205003	Screw M4 x 8	7
39	S120205003	Screw	4
40	B62400812	Screw M4 x 8	2
41	B12400432	Screw M4 x 4	1
42	197100021	Support pole (S)	1
43	197100022	Screw	4
44	S120203033	Screw M4 x 6	2
45	197150001	Screw	1
46	197400012	Rubber plug	1
47	197170001	Push button	1
48	197170002	Spring	1
49	S150656012	O-type ring 5 x 1.8G	1
50	110440009	Washer	1
51	S4B1202008	C-type ring 4	1
52	S150224001	Screw M3 x 3	1
53	S150220041	Screw M4 x 10	2
54	110150005	Rubber plug	1
55	110300002	Oil sight gauge	1

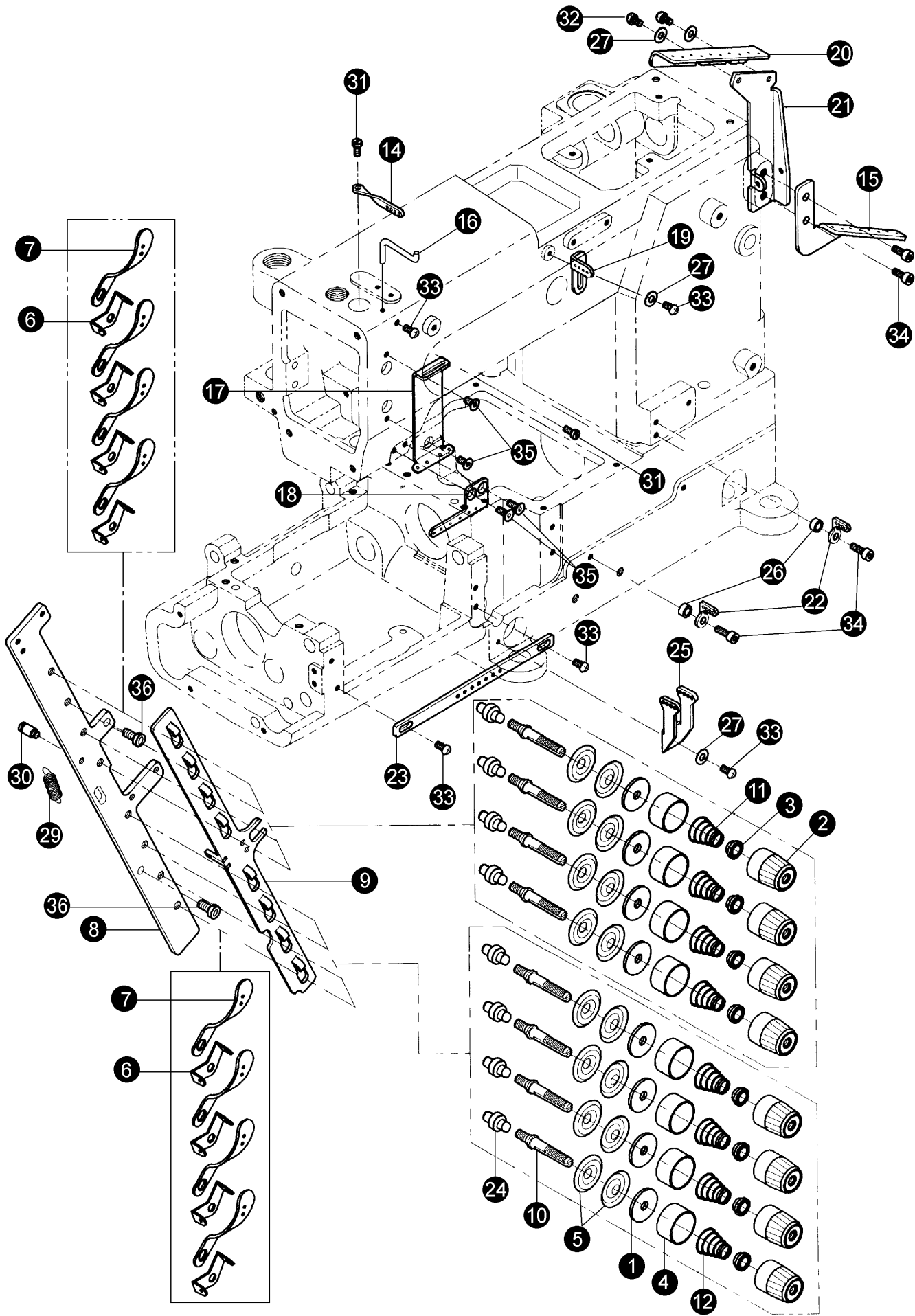

7

6

30

29

36

8

7

6

31

14

16

17

18

23

33

9

32

27

20

21

15

19

27

33

34

35

31

35

26

22

34

25

27

33

11

3

2

24

10

5

1

4

12

3. THREAD TENSION MECHANISM

No.	Ref. No.	Description	Qt.
1	028283007	Felt	8
2	155A10009	Thread tension nut	8
3	155A10007	Spring post	8
4	1102h0005	Thread tension spring retainer	8
5	022160005	Tension disc	16
6	116200015	Tension disc eyelet	8
7	116200016	Tension disc eyelet	8
8	197210001	Tension post support	1
9	197210002	Thread releaser	1
10	1102h0003	Tension post	8
11	155A10004	Spring	4
12	155A10005	Spring	4
13	S150220041	Screw M4 x 10	2
14	197200001	Thread eyelet	1
15	197200002	Looper thread eyelet	1
16	110200026	Thread take-up eyelet	1
17	197200004	Thread eyelet	1
18	197200005	Thread eyelet	1
19	197200006	Thread eyelet	1
20	197220001	Thread guide	1
21	197220002	Thread guide support	1
22	197200007	Thread eyelet	2
23	197200009	Thread eyelet	1
24	197210005	Roller	8
25	197200010	Tension disc separator	1
26	197200008	Collar	2
27	008230003	Washer 4	4
29	197210004	Spring	1
30	197210003	Screw	1
31	058600005	Screw SM9/64" (3.57) x 40 x 7	1
32	S150237002	Screw M4 x 5	2
33	B62400812	Screw M4 x 8	5
34	S150220041	Screw M4 x 10	4
35	S120205003	Screw	4
36	S150220007	Screw M5 x 10	2

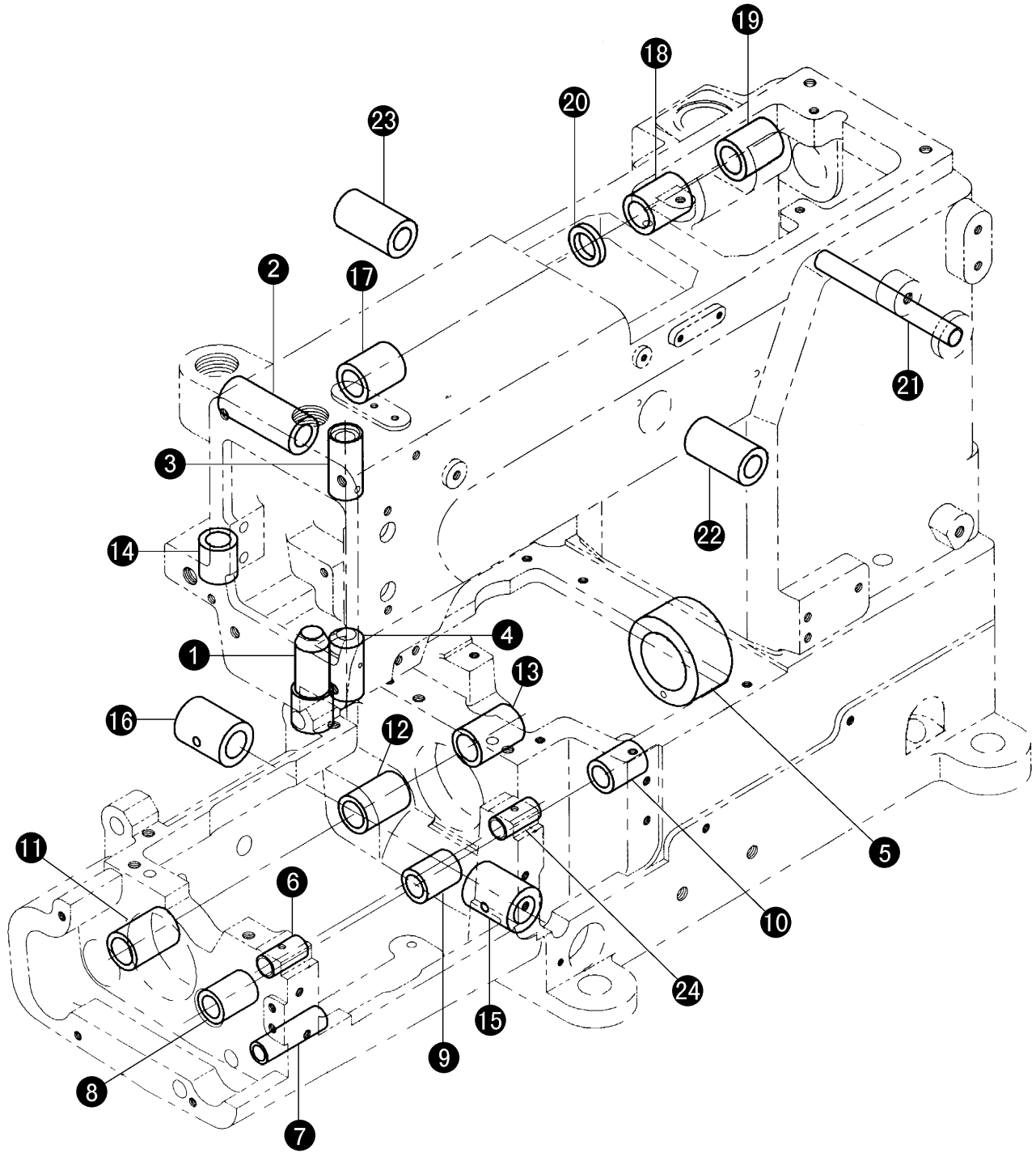

4. BUSHING

No.	Ref. No.	Description	Qt.
1	110600007	Bushing	1
2	197800003	Bushing	1
3	197800001	Bushing	1
4	197800002	Bushing	1
5	197800008	Bushing	1
6	197800012	Bushing	1
7	197800009	Bushing	1
8	197800017	Bushing	1
9	197800018	Bushing	1
10	197800019	Bushing	1
11	197800014	Bushing	1
12	197800015	Bushing	1
13	197800016	Bushing	1
14	197800004	Bushing	1
15	197800010	Bushing	1
16	197800011	Bushing	1
17	197800005	Bushing	1
18	197800006	Bushing	1
19	197800007	Bushing	1
20	197800020	Oil seal	1
21	197600007	Bushing	1
22	197300007	Bushing	1
23	197300008	Bushing	1
24	197800013	Bushing	1

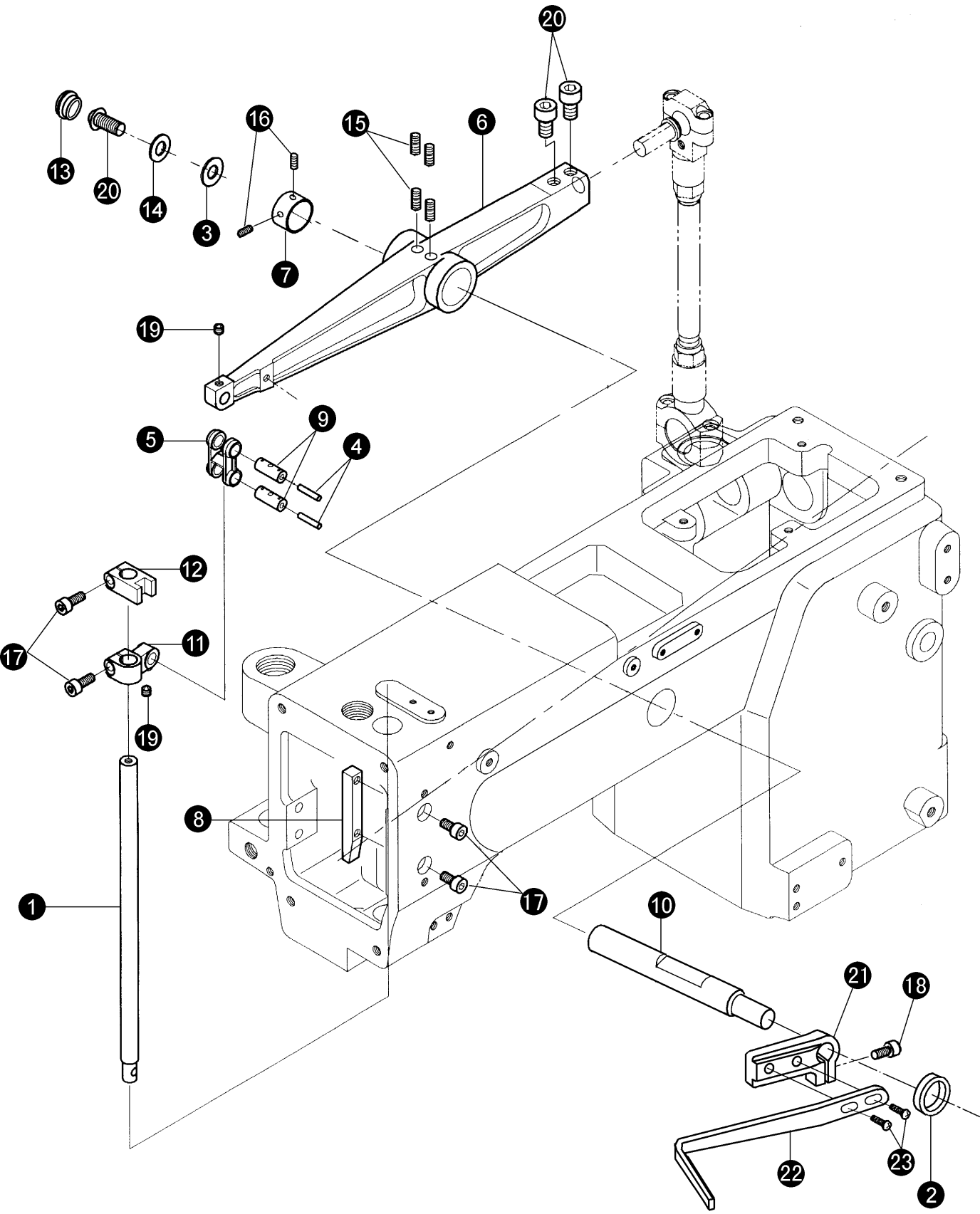

5. NEEDLE BAR MECHANISM

No.	Ref. No.	Description	Qt.
1	197300001	Needle bar	1
2	110280000	Oil seal	1
3	197300005	Washer	1
4		Wool	2
5	197310002	Link	1
6	197310001	Needle lever	1
7	197300006	Collar	1
8	197300003	Needle bar guide	1
9	197310003	Pin	2
10	197300004	Needle lever stud	1
11	197310004	Needle bar clamp	1
12	197300002	Slide block	1
13	197300009	Rubber plug	1
14	S8A3103013	Washer 6	1
15	B12060632	Screw M6 x 6	4
16	B12500532	Screw M5 x 5	2
17	S150220041	Screw M4 x 10	4
18	S150220004	Screw M5 x 14	1
19	S150225002	Screw M4 x 4	2
20	S150220042	Screw M6 x 10	3
21	197230001	Thread take-up crank	1
22	197230002	Thread take-up lever	1
23	B62400812	Screw M4 x 8	2

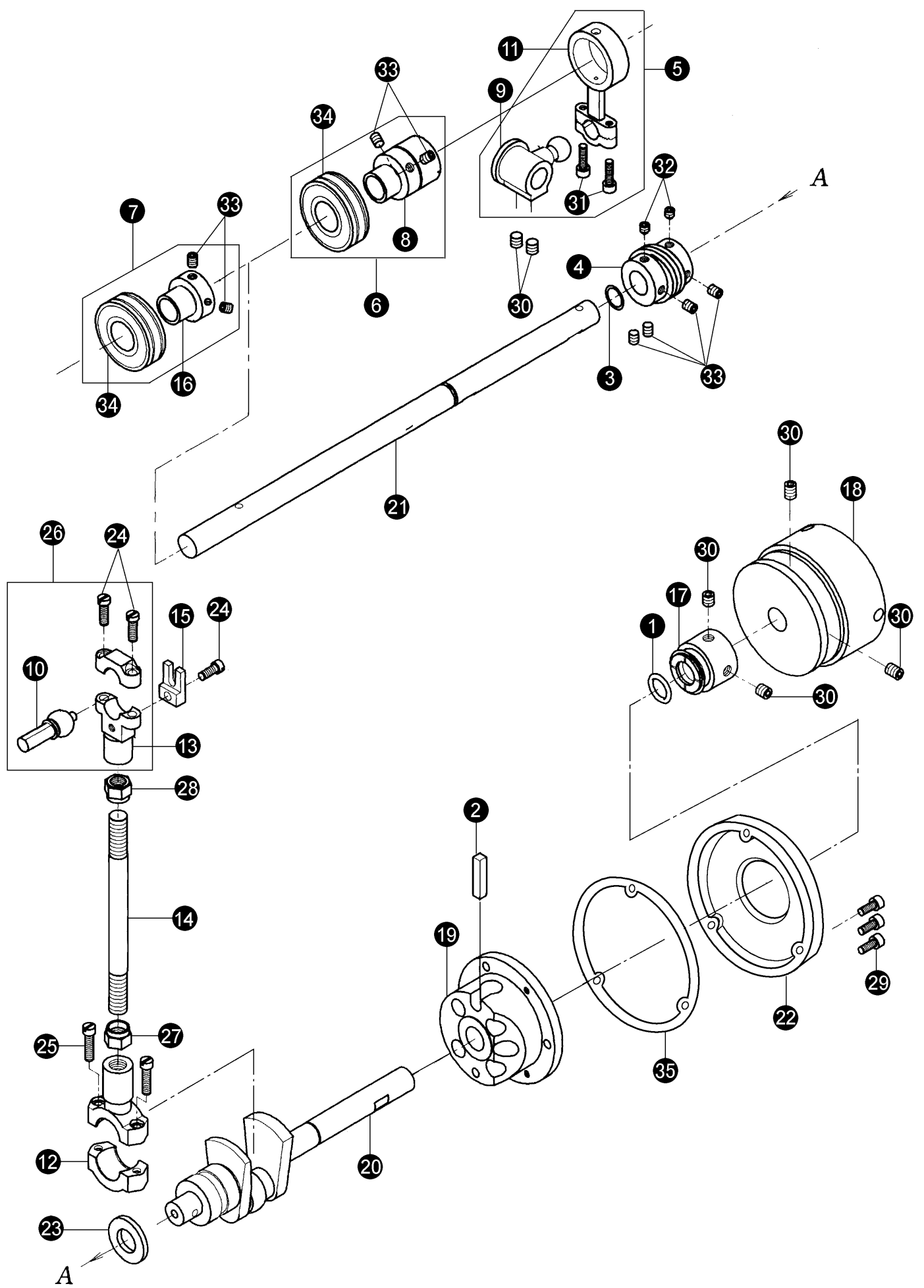

6. CRANK SHAFT MECHANISM

No.	Ref. No.	Description	Qt.
1	S150656026	O-type ring 13.2 x 1.8G	1
2		Wick	1
3	S150656013	O-type ring 9.5 x 1.8	1
4	197450001	Worm	1
5	197410000	Connecting rod asm.	(1)
6	197440000	Bearing asm. (right)	(1)
7	197430000	Bearing asm. (left)	(1)
8	197440001	Eccentric wheel	1
9	197410001	Crank rod	1
10	197422003	Connecting rod ball	1
11	197410002	Connecting rod	1
12	197421002	Ball joint	1
13	197422001	Ball joint	2
14	197420001	Connecting bar	1
15	197422002	Stopper	1
16	197430001	Sleeve	1
17	197460001	Collar	1
18	197470001	Pulley	1
19	197400003	Flange	1
20	197421001	Crank shaft	1
21	197400001	Shaft	1
22	197400002	Cover	1
23	197400005	Washer	1
24	197422004	Screw SM11/64"(4.37) x 40 x 14	3
25	197421003	Screw SM11/64"(4.37) x 40 x 18	2
26	197422000	Connecting rod asm.	(1)
27	190550002	Nut (down) SM3/8"(9.53) x 28	1
28	190550004	Nut (up) SM3/8"(9.53) x 28	1
29	S150220041	Screw M4 x 10	3
30	B12060632	Screw M6 x 6	6
31	S150220038	Screw M4 x 14	2
32	S150225006	Screw M5 x 6	2
33	B12500532	Screw M5 x 5	8
34	058530004	Bearing 6203	2
35	197400004	Washer	1

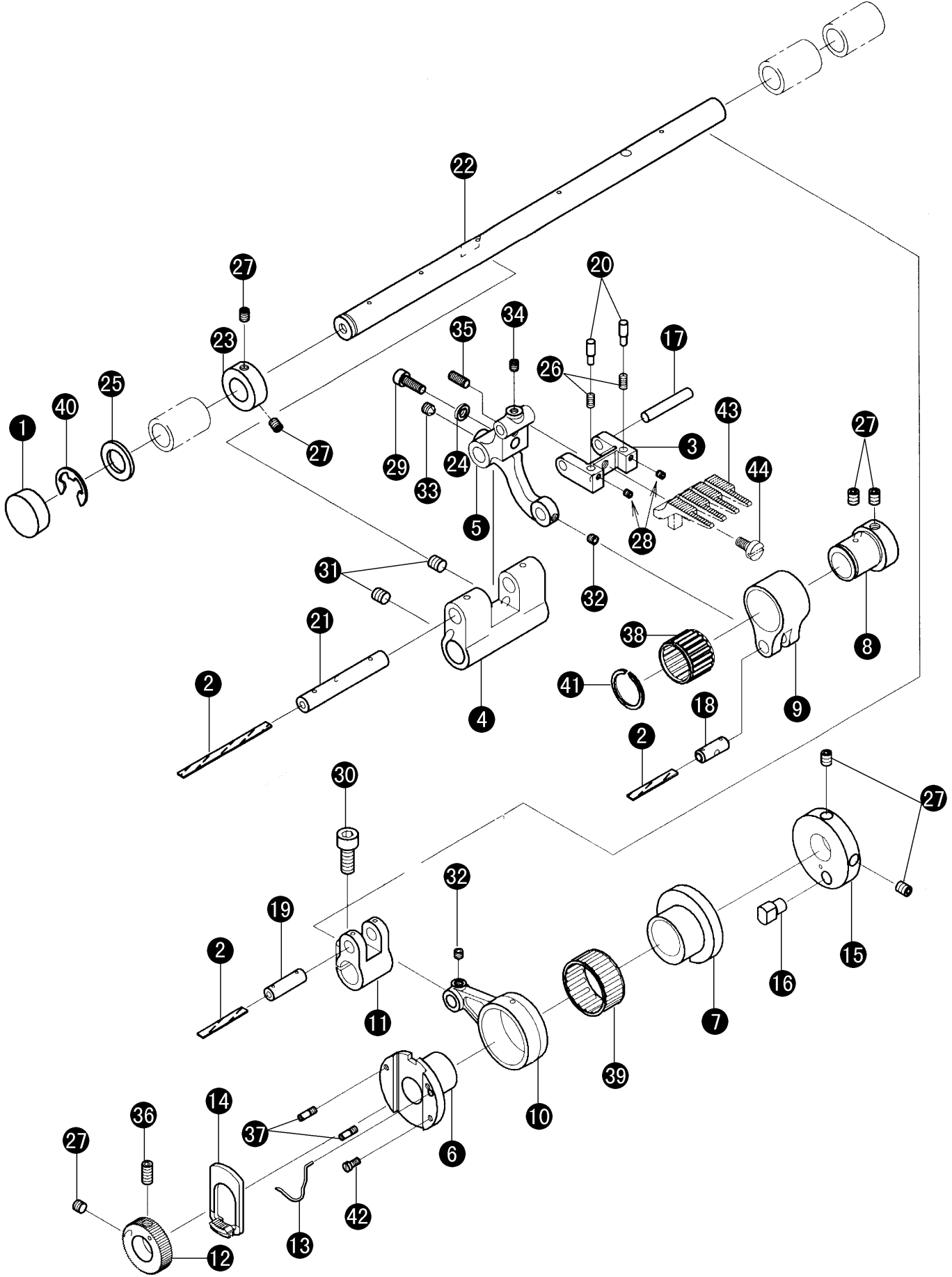

7. FEED MECHANISM

No.	Ref. No.	Description	Qt.
1	197100013	Rubber plug	(1)
2		Wool	2
3	197510002	Feed dog holder	1
4	197510001	Feed rocker	1
5	197510003	Feed bar	1
6	197520007	Feed regulating eccentric	1
7	197520005	Feed eccentric	1
8	197510004	Eccentric	1
9	197510005	Rocker link	1
10	197520006	Feed link	1
11	197520003	Feed crank	1
12	197520010	Sprocket wheel	1
13	197520008	Spring	1
14	197520009	Regulating plate	1
15	197520001	Eccentric collar	1
16	197520002	Eccentric block	1
17	197510006	Feed bar shaft	1
18	008400017	Rocker link shaft	1
19	197520004	Feed link shaft	1
20	197510008	Pin	2
21	197510007	Feed link shaft	1
22	197500002	Feed shaft	1
23	197500003	Collar	1
24	008230003	Washer 4	1
25	197500004	Washer	1
26	197510009	Spring	2
27	B12500532	Screw M5 x 5	7
28	S150224001	Screw M3 x 3	2
29	S150220041	Screw M4 x 10	1
30	B18061432	Screw M6 x 14	1
31	B12060632	Screw M6 x 6	2
32	S150225002	Screw M4 x 4	1
33	S150225006	Screw M5 x 6	1
34	B12400432	Screw M4 x 4	1
35	S150224019	Screw M4 x 10	1
36	110460013	Screw	1
37	110460011	Screw	1
38	008400016	Needle bearing asm.	1
39	S150866019	Needle bearing K25 x 29 x 13	1
40	S4A1002010	E-type ring 9	1
41	197510010	C-type ring	1
42	S120203015	Screw M3 x 5	1
43	197510011	Feed dog	1
44	022400015	Screw SM11/64"(4.37) x 40 x 10	1

8. LOOPER MECHANISM

No.	Ref. No.	Description	Qt.
1	197400009	Looper rocker guide plate	1
2	197400007	Looper rocker stopper	1
3	197400010	Shaft	1
4	197400011	Stud	1
5	197480001	Looper rocker	1
6		Wick	2
7	197400012	Rubber plug	1
8		Wick	1
9	197490001	Tack-up lever	1
10	197490002	Eccentric	2
11	197490003	Link	2
12	197490005	Take-up drive lever	1
13	1974a0001	Looper drive lever	1
14	197400015	Lever	1
15	008400017	Pin	2
16	197400013	Shaft	1
17	197400016	Pin	1
18	197400018	Looper shaft	1
19	197480002	Set shaft	1
20	197400017	Retainer bar holder	1
21	197480003	Washer	2
22	008230003	Washer 4	2
23	197400019	Collar	1
24	197400022	Washer	1
25	197400014	Washer	1
26	S8A3103013	Washer 6	1
27	197400020	Collar	1
28	197400021	Washer	1
29	197480000	Looper holder	(1)
30	197400008	Spring	1
31	197480004	Spring	1
32	197480005	Spring	1
33	197480006	Bushing	1
34	197480007	Bushing	1
35	S150220019	Screw M4 x 8	1
36	B18061432	Screw M6 x 14	1
37	S150220019	Screw M4 x 8	2
38	B18061432	Screw M6 x 14	1
39	S150220004	Screw M5 x 14	2
40	B12400432	Screw M4 x 4	2
41	B12500532	Screw M5 x 5	7
42	197400025	O-type ring 6 x 1	1
43	S150866019	Needle bearing K25 x 29 x 13	2
44	S150866008	Bearing 81101 (AXK12 x 26 x 8)	1
45	016500015	E-type ring 5	1
46	S150649003	E-type ring 8	1
47	197490004	C-type ring	2

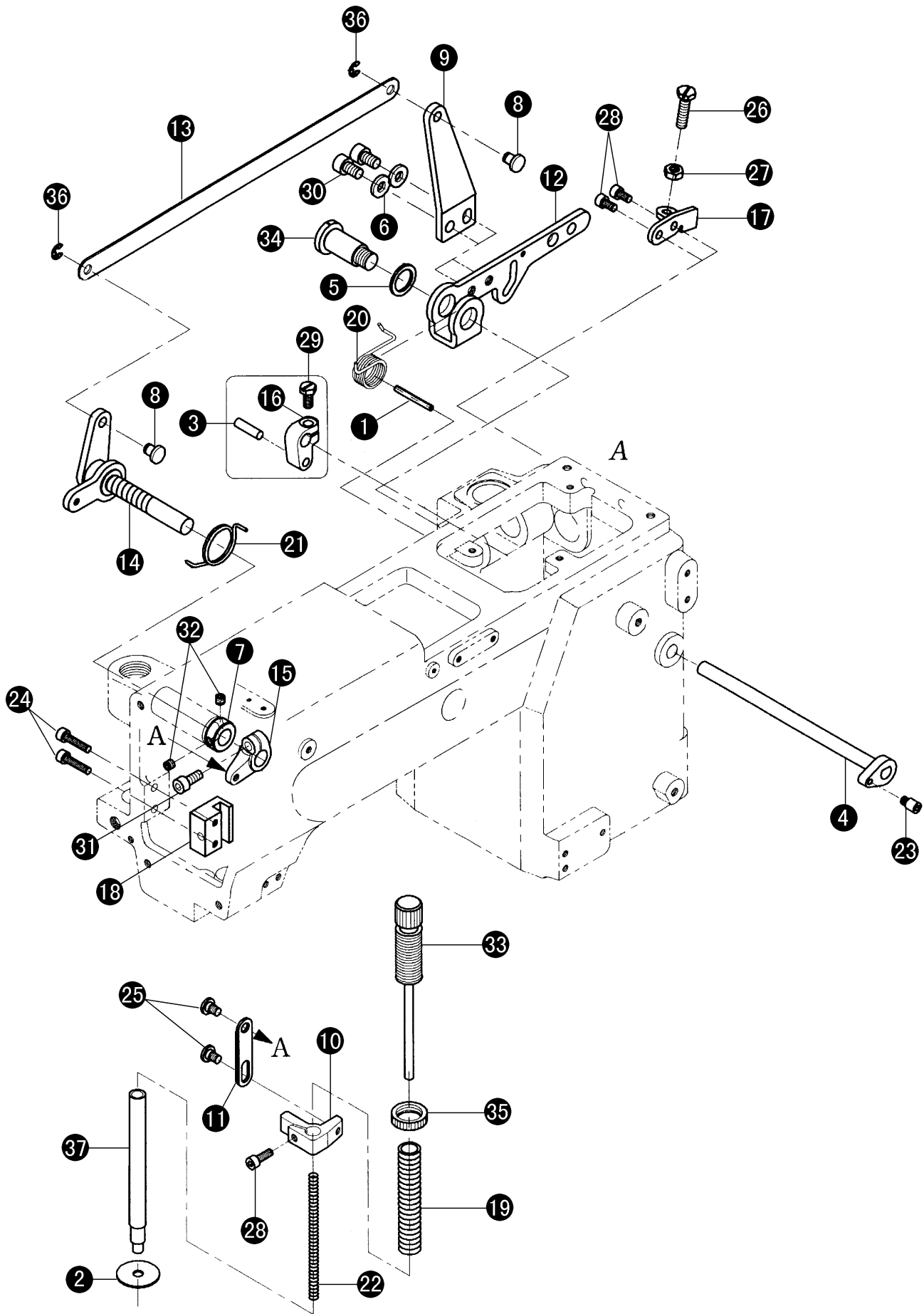

9. PRESSER FOOT MECHANISM

No.	Ref. No.	Description	Qt.
1	S150446023	Pin 3 x 28	1
2	043600005	Oil fence	1
3	008600018	Pin	1
4	197620002	Shaft	1
5	197600003	Washer	1
6	008310001	Washer 6	2
7	110400006	Collar	1
8	197630002	Pin	2
9	197630001	Lever	1
10	197640001	Presser bar slide block	1
11	197640002	Plate	1
12	197600001	Presser bar lever	1
13	197630003	Lever	1
14	197631000	Crank asm.	1
15	197640003	Crank, front	1
16	197610001	Crank, rear	1
17	197600006	Stopper	1
18	197600008	Slide block guide	1
19	197600011	Spring	1
20	197600004	Spring	1
21	197600005	Spring	1
22	197600010	Spring	1
23	197620001	Shaft	1
24	B18401622	Screw M4 x 16	2
25	197630005	Screw	2
26	197730005	Screw	1
27	197730008	Nut	1
28	S150220041	Screw M4 x 10	3
29	S150204002	Screw M5 x 10	1
30	S150220042	Screw M6 x 10	2
31	S150220007	Screw M5 x 10	1
32	B12400432	Screw M4 x 4	2
33	197650001	Screw	1
34	197600002	Shaft	1
35	110610002	Nut	1
36	S4B1202008	E-type ring 4	2
37	197600009	Presser bar	1

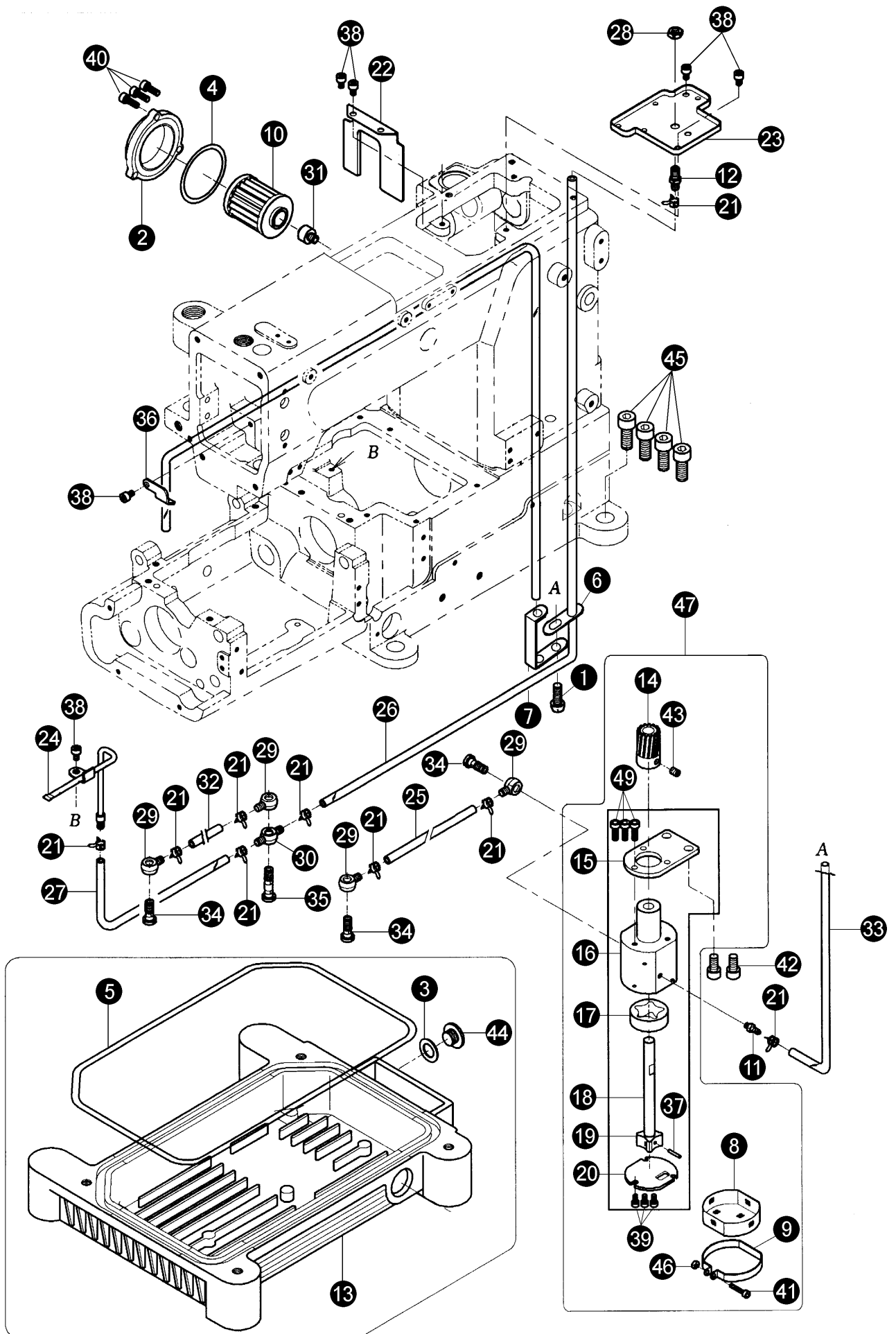

10. LUBRICATION MECHANISM

No.	Ref. No.	Description	Qt.
1	S120203033	Screw M4 x 6	1
2	028700023	Oil filter cover	1
3	110310004	Seal ring	1
4	S8A3107004	O-type ring (GB1235-85)	1
5	197900002	Seal ring	1
6	110300014	Oil tube clamp	1
7	116300015	Oil tube clamp	1
8	197910006	Oil filter mesh	1
9	197910007	Collar	1
10	028770001	Oil filter asm.	(1)
11	197900009	Nozzle	1
12	197900004	Nozzle	1
13	197900001	Oil reservoir	1
14	197910001	Pump gear	1
15	197910003	Set plate	1
16	197910002	Pump	1
17	197910004	Outer gear	1
18	197911001	Pump shaft	1
19	197911002	Inner gear	2
20	197910005	Cover	1
21	110300012	Oil tube clamp	9
22	197900015	Oil fence	1
23	197900003	Oil releaser	1
24	197920000	Oil tube	(1)
25	197900005	Oil tube	1
26	197900005	Oil tube	1
27	197900005	Oil tube	1
28	S120501011	Nut M6	1
29	110340002	Joint	4
30	110340001	Joint	1
31	028700022	Screw	1
32	197900005	Oil tube	1
33	197900005	Oil tube	1
34	197900008	Screw	3
35	197900007	Screw	1
36	197900006	Tube holder	1
37	S150446024	Pin 2 x 11.8	1
38	S120203031	Screw M4 x 5	6
39	B60300612	Screw M3 x 6	3
40	B60401412	Screw (GB818-85)	3
41	S15022029	Screw M3 x 15	1
42	B18061432	Screw M6 x 14	2
43	B12500532	Screw M5 x 5	2
44	028700026	Screw	1
45	S150220043	Screw M8 x 16	4
46	S120501001	Nut M3	1
47	197910000	Oil pump asm.	(1)
49	S150220002	Screw M4 x 12	3

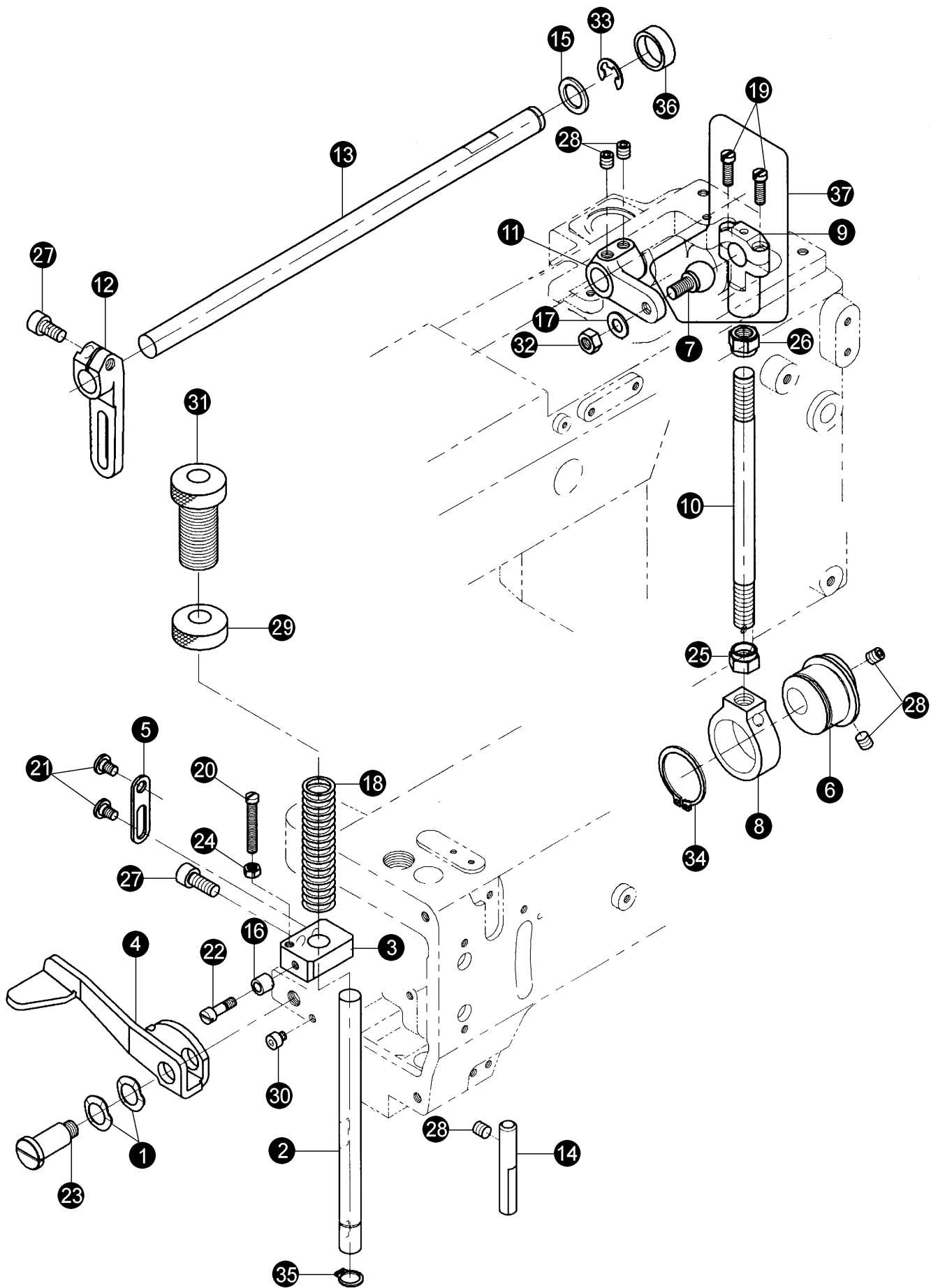

11. REAR PULLEY MECHANISM (1)

No.	Ref. No.	Description	Qt.
1	197150002	Washer 12	2
2	197700001	Presser bar	1
3	197710001	Lifter block	1
4	197700004	Lever	1
5	197630004	Lifter plate	1
6	197740003	Puller driving eccentric	1
7	197741001	Ball joint	1
8	197740004	Connecting bar	1
9	197422001	Ball joint	(1)
10	197740002	Connecting bar	1
11	197740001	Crank, right	1
12	197730001	Crank, left	1
13	197700011	Shaft	1
14	197700006	Stopper	1
15	197700012	Washer	1
16	197710002	Roll pole	1
17	1102a0006	Washer	1
18	197700003	Spring	1
19	197422004	Screw SM11/64"(4.37) x 40 x 14	2
20	197710004	Screw SM11/64" x 40 x 30	1
21	197630005	Screw	2
22	197710003	Screw	1
23	197700005	Pin	1
24	028100035	Nut SM11/64"(4.37) x 40	1
25	190550002	Nut	1
26	190550004	Nut	1
27	B18061432	Screw M6 x 14	2
28	B12060632	Screw M6 x 6	5
29	197700013	Nut	1
30	B18401622	Screw M4 x 16	1
31	197700002	Nut	1
32	S120501011	Nut M6	1
33	S4A1002010	E-type ring 9	1
34	S150649007	Collar 28	1
35	S150649002	E-type ring 10	1
36	197100013	Rubber plug	(1)
37	197741000	Ball joint asm.	1

12. REAR PULLY MECHANISM (2)

No.	Ref. No.	Description	Qt.
1	197720006	Sleeve	2
2	197720012	Stopper	1
3	197720005	Sleeve	1
4	197730007	Screw	1
5	197720001	Rear pulley Holder	1
6	197720003	Rear pulley	1
7	197720014	Stopper	1
8	197720011	Connecting plate	1
9	197720000	Rear pulley bracket asm.	(1)
10	197700007	Rear pulley gear	1
11	197720002	Shaft	1
12	197700009	Shaft	1
13	197730004	Washer	2
14	197720015	Washer	1
15	197700010	Guide collar	1
16	197700008	Sleeve	2
17	110E10003	Washer	1
18	197720010	Pulley plate spring	1
19	197720007	Bushing	1
20	197720008	Bushing	1
21	197720009	Bushing	1
22	197720016	Screw SM1/8"(3.18) x 44 x 6	6
23	197720004	Screw	3
24	197720013	Pin	1
25	197730005	Screw	1
26	197730008	Nut SM7/32"(5.56) x 32	2
27	197730006	Slide block	1
28	S150220002	Screw M4 x 12	3
29	S150866049	Needle bearing K9.65 x 14.3 x 8	2
30	B12400432	Screw M4 x 4	1
31	S15022042	Screw M6 x 10	1
32	B12400432	Screw M4 x 4	3
33	S150560005	Nut M8	2
34	S150866045	Bearing HFL2026	2
35	S8A3103018	E-type ring 6	1
36	197730002	Lever	1
37	197730003	Bearing sleeve	2

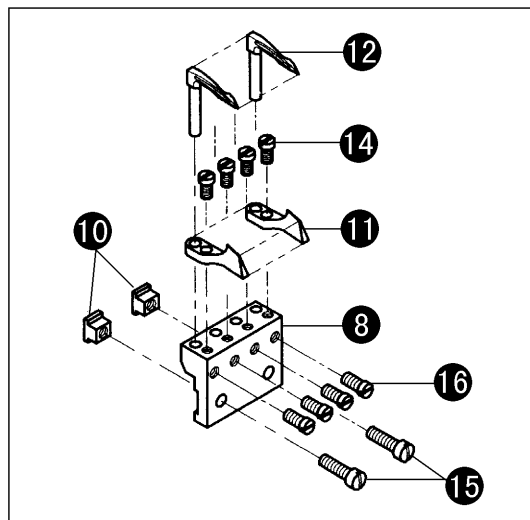
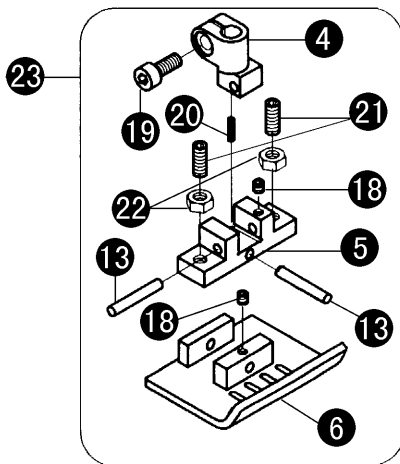
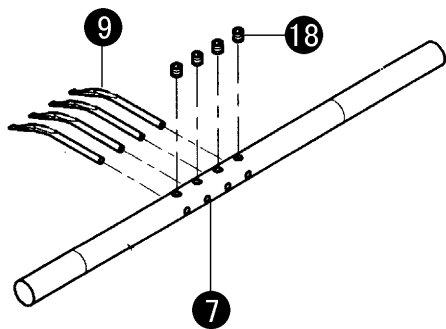
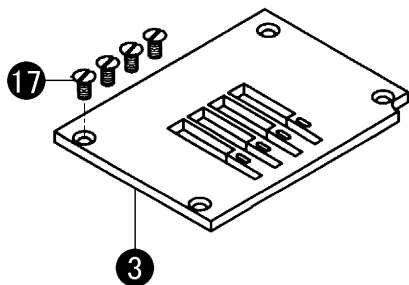
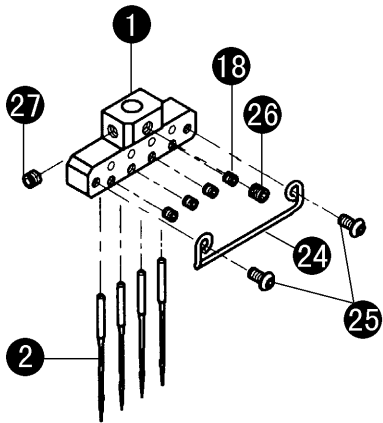

13. GAUGE PARTS

No.	Ref. No.	Description	Qt.
1	197320002	Needle clamp	1
2	S150901005	Needle DV x 57 14	4
3	197100024	Throat plate	1
4	197660001	Presser foot connector	1
5	197660003	Presser foot connecting plate	1
6	197661000	Presser foot bottom	1
7	197400024	Retainer holder	1
8	197480009	Looper holder	1
9	197400026	Retainer looper	4
10	197480008	Bracket	2
11	197480010	Needle guard	4
12	197480011	Looper	4
13	19766004	Pin	2
14	197480014	Screw SM1/8"(3.18) x 44 x 6	4
15	197480013	Screw SM9/64"(3.57) x 40 x 11.5	2
16	197480012	Screw SM9/64"(3.57) x 40 x 7	4
17	110400023	Screw	4
18	S150224001	Screw M3 x 3	10
19	S150220041	Screw M4 x 10	1
20	197660002	Spring	1
21	S150224019	Screw M4 x 10	2
22	S120501003	Nut M4	2
23	197660000	Presser foot asm.	1
24	197320001	Thread guide	1
25	B60300612	Screw M3 x 6	2
26	S150225002	Screw M4 x 4	1
27	B12400432	Screw M4 x 4	1

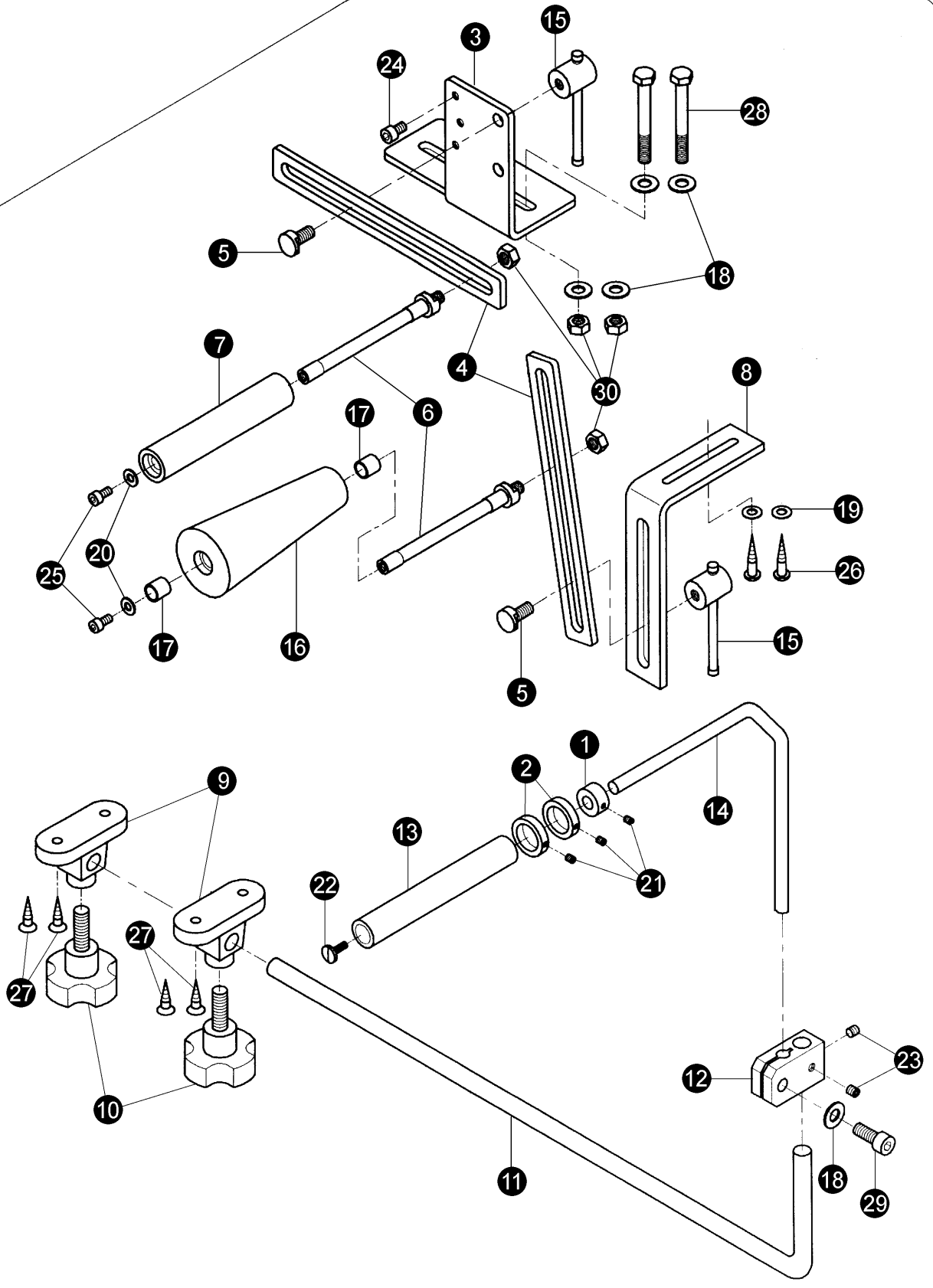

14. GUIDE ROLLER MECHANISM

No.	Ref. No.	Description	Qt.
1	197F01303	Collar	1
2	197F01302	Collar	2
3	197F01006	Rear roller bracket	1
4	197F01103	Slide plate	2
5	197F01009	Screw	2
6	197F01102	Shaft	2
7	197F01101	Rear guide roller	1
8	197F01007	Bracket	1
9	197F01401	Bracket	2
10	197F01402	Knob	2
11	197F01008	Support pole	1
12	197F01010	Connecting	1
13	197F01301	Roller	1
14	197F01304	Shaft	1
15	197F01500	Handle asm.	2
16	197F01211	Tape roller	1
17	197F01212	Bushing	2
18	S150632003	Washer 8	5
19	S150632002	Washer 6	2
20	S8A3103006	Washer 5	2
21	S150224009	Screw M4 x 6	3
22	110150007	Screw	1
23	S150224003	Screw M6 x 8	2
24	S150220032	Screw M6 x 10	1
25	S150220015	Screw M5 x 12	2
26	S150241007	Wood screw 6 x 30	2
27	W050101020	Wood screw 6 x 30	4
28	S150274004	Screw M8 x 65	2
29	S150220006	Screw M8 x 20	1
30	W120501017	Nut M8	4

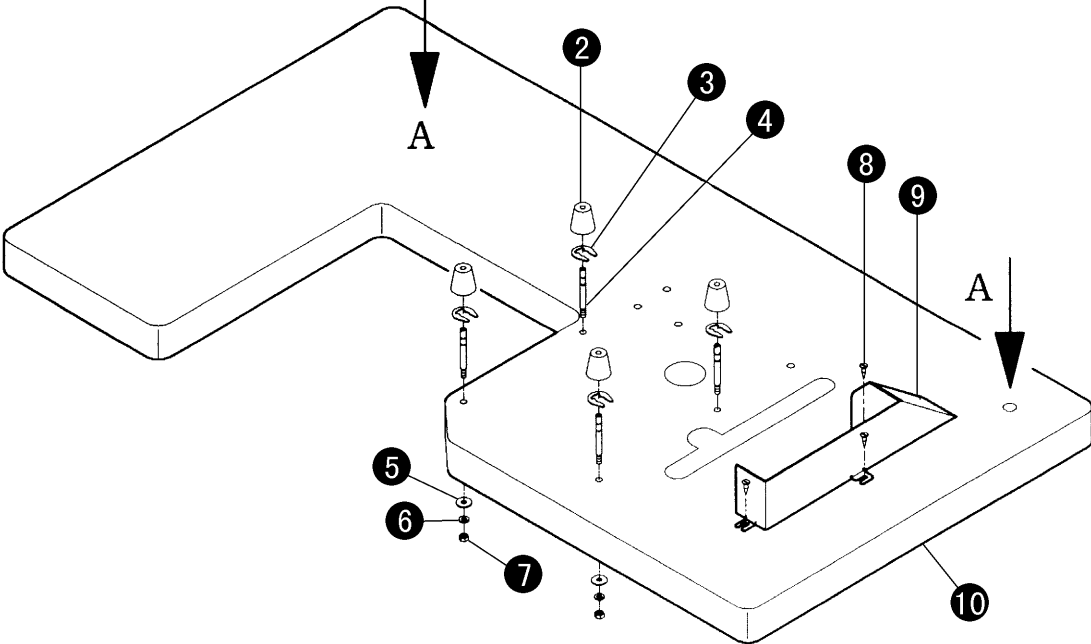
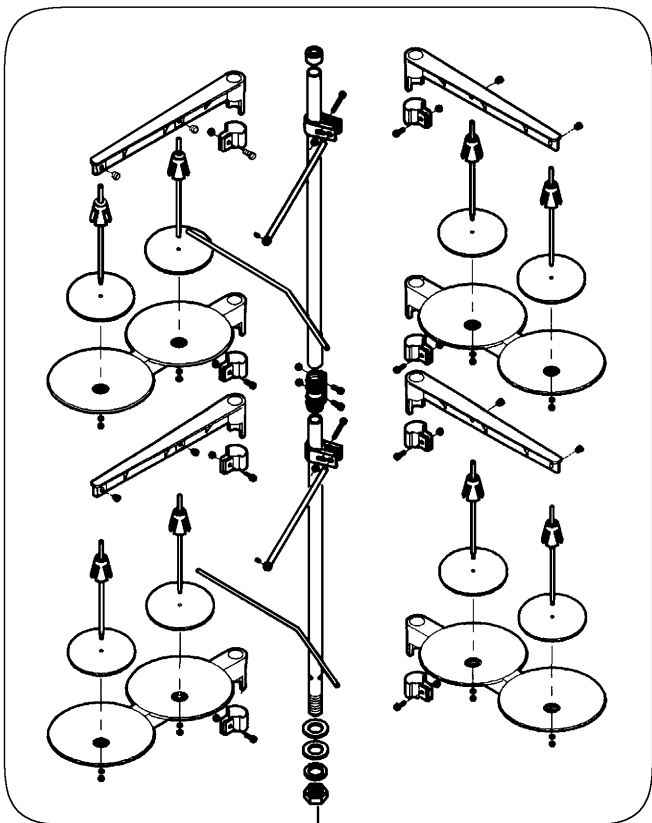

15. THREAD STAND AND TABLE

No.	Ref. No.	Description	Qt.
1	197X0000	GXJ-8 Thread stand asm.	1
2	110F01002	Cushion rubber	4
3	S8A3103018	E-type ring 6	4
4	197F01003	Bolt	4
5	S150632002	Washer 6	4
6	S4A0400011	Washer 6	4
7	S120501011	Nut 6	4
8	W050101015	Wood screw 5 x 18	3
9	197F01002	Lower Belt cover	1
10	197F01005	Table	1

321-12/-9W assembly diagram of main thread guide assy

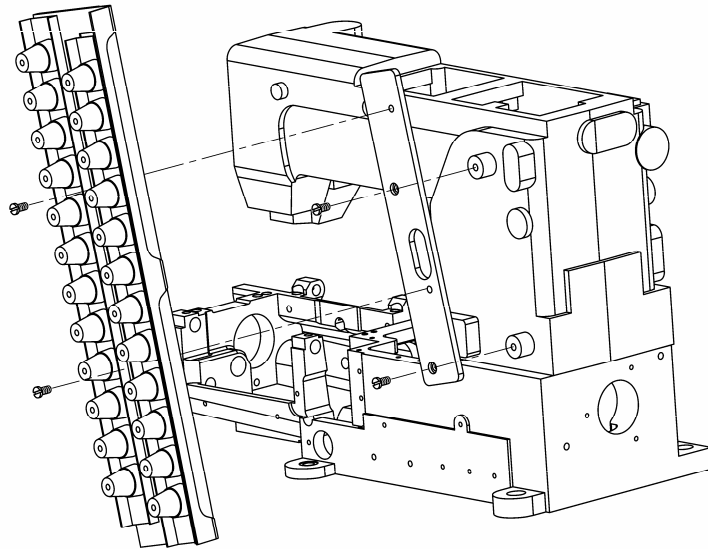

321 series of instructions to adjust the length of needle

321 series of adjustments of the length of needles used during the 321 series, there will be two common sizes of needle, the differences between them are: the length of the difference of 2mm. So, for the convenience of customers, will be attached to a length of needles to adjust pads to adjust to customers on their own needle exchange. As follows

First, the factory is set to: the early positioning in the assembly (standard SCHMETZ Needle DVX57, 14 #), the use of 3mm-thick pads to adjust the length of needle positioning the needle bar connector (197310004) and the needle bar and slider (197300002) of the distance between, as shown

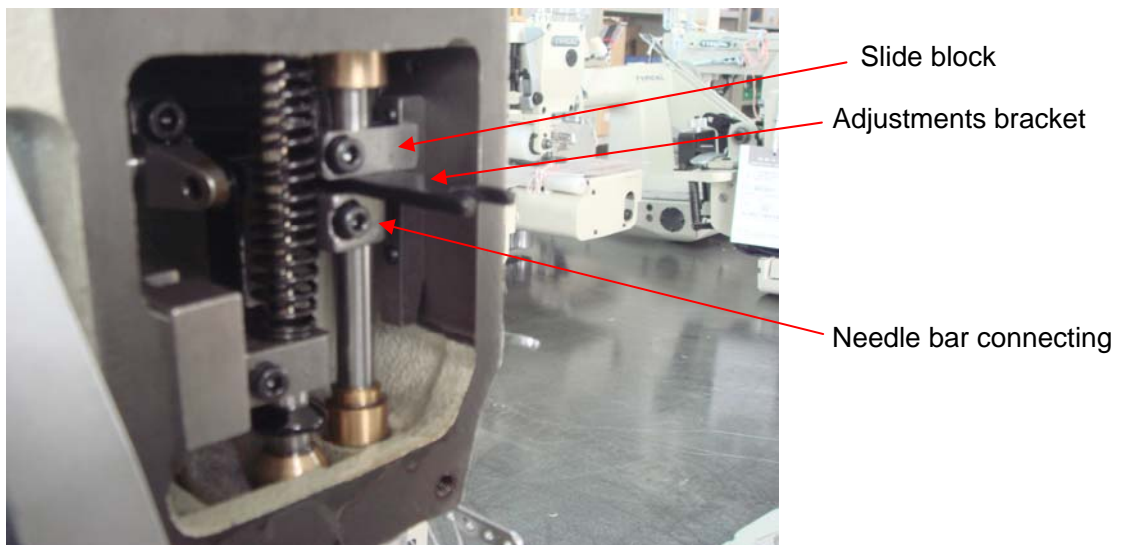

Second, the customers changed to a shorter course, with a larger needle (recommended SCHMETZ Needle UY113 GS, 16 #), change is: Loosen the needle bar connector screw, the needle bar down, with 1mm thick pads to adjust the length of needle positioning the needle bar connector (197310004) and the needle bar and slider (197300002) the distance between the can.

Note: You can not use more than 16 # machine needle, if the need to install more than 16 needle, please adjust the machine or replace other models.

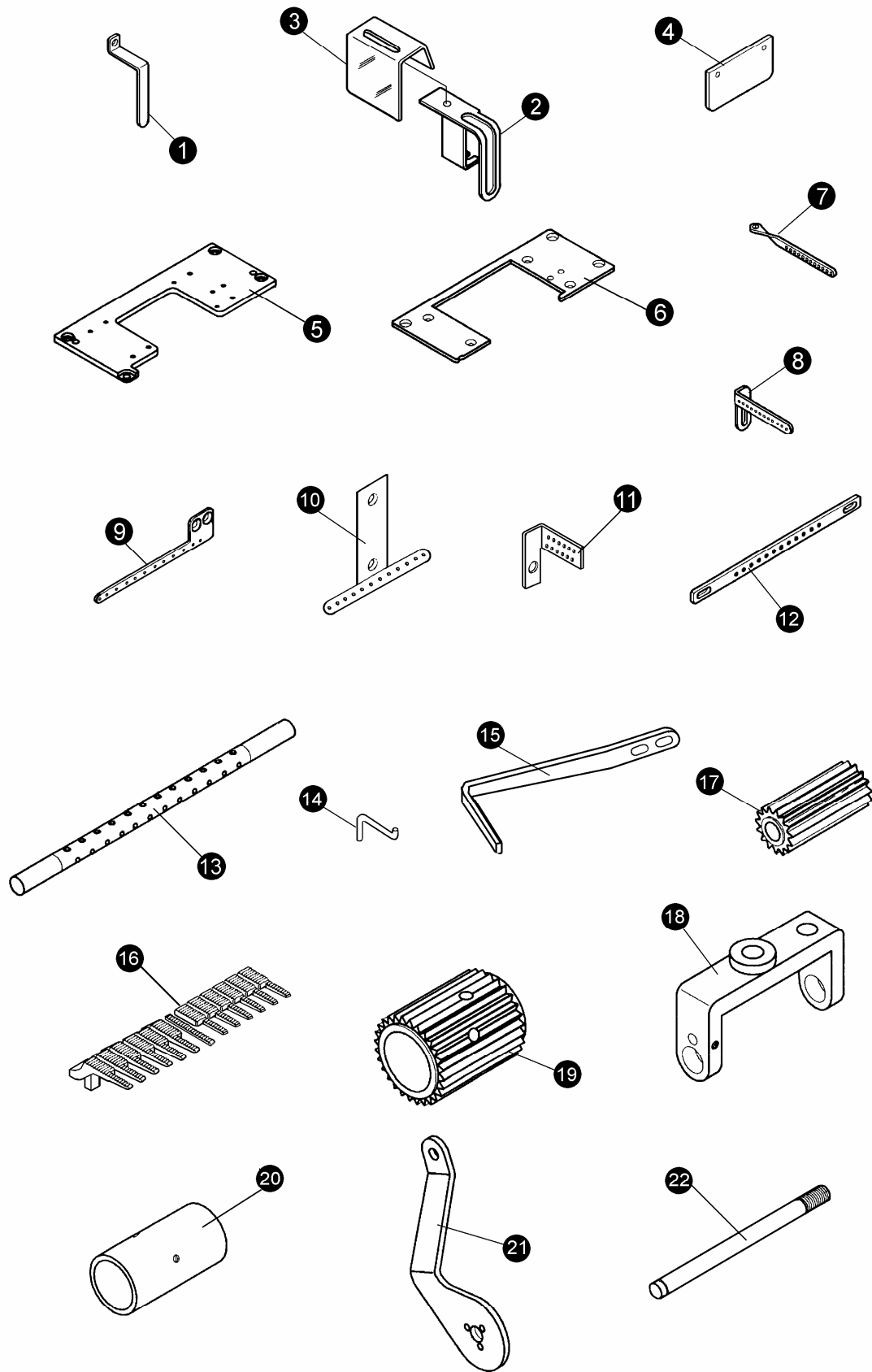

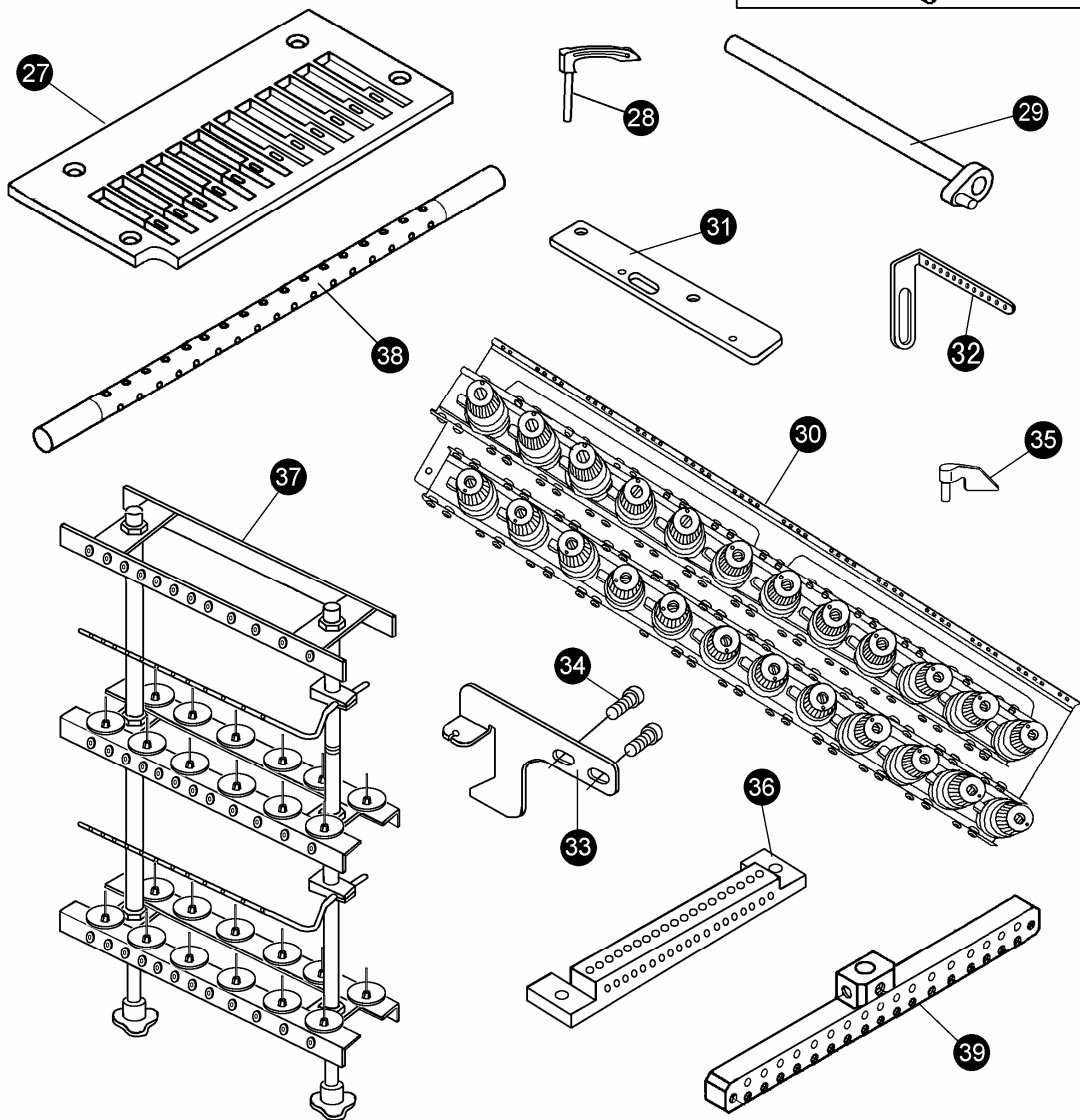
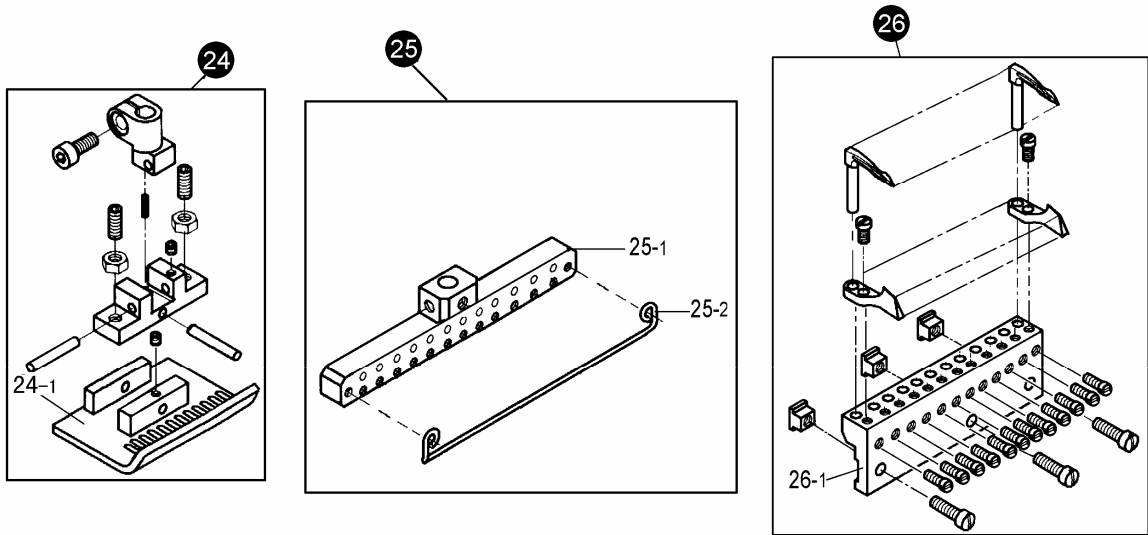

Special-use parts for 321-12 / 321-9W

No.	Ref.No.	Description	Qt.	
			321-12	321-9W
1	197C00001	Thread take-up lever guard	1	1
2	197C10001	Needle bar guard	1	1
3	197C10002	Needle bar cover	1	1
4	197C00002	Eye guard	1	1
5	197C00003	Needle plate support bracket	1	
6	197C00004	Cover	1	
7	197C00005	Thread eyelet	1	1
8	197C00006	Thread eyelet	1	1
9	197C00007	Thread eyelet	1	1
10	197C00008	Thread eyelet	1	1
11	197C00010	Thread eyelet	2	2
12	197C00011	Thread eyelet	1	1
13	197C00013	Thread take-up lever	1	
14	197C00017	Thread take-up clasper	1	1
15	197C00009	Thread take-up lever	1	1
16	197C00012	Feed dog	1	
	197K00004	Feed dog		1
17	197C00014	Rear pulley gear	1	1
18	197C50001	Rear pulley bracket	1	1
19	197C50002	Rear pulley	1	1
20	197C50003	Rear pulley bushing	1	1
21	197C50004	Connecting plate	1	1
22	197C50005	Rear pulley Shaft	1	1
24	197C20000	Presser foot asm	1	
24-1	197C20001	Presser foot plate	1	
	197K20000	Presser foot plate		1
25	197C40000	Needle clamp asm	1	
25-1	197C40001	Needle clamp	1	
25-2	197C40002	Thread guide	1	1
26	197C30000	Looper holder asm	1	
26-1	197C30001	Looper holder	1	
	197K30001	Looper holder		1
27	197C00016	Needle plate	1	
	197K00005	Needle plate		1
28	197K30002	Looper		9
29	197C61000	Thread release front crank assy	1	1
30	197C60002	Main thread guide assy	1	1
31	197C60001	Connection plate	1	1
32	197C00019	Thread guide	1	1
33	197C00027	Presser foot positioning plate	1	1
34	S150220014	Screw M6X12	2	2
35	197K30003	Needle guard plate		9
36	197K30004	Needle guard plate bracket		1
37	197CX0000	Thread stand GXJ-24	1	1
38	197K00002	Thread take-up lever (1/8")		1
39	197K10002	Needle holder (1/8")		1

Besides adjusting stitch, please laypeople don't debug or maintain.

Parts are subject to changes in design without prior notice.

XI'AN TYPICAL INDUSTRIES CO., LTD.

Add: No. 1 Taibai South Road,
Xi'an, P. R. China - 710068
Tel : +86 -29 -88279091 88279150
Fax : +86 -29 -88249715 88245215
E-mail: typical@chinatypical.com
Http: www.chinatypical.com
Http: www.globalsources.com

2005. 04. 21