



Model

# 1345-2C

Revision 0 Preliminary Copy February 28, 2023

## Technical Manual & Part List



Atlanta Attachment Co.

362 Industrial Park Drive

Lawrenceville, GA 30046

+1 (770-963) 7369

[www.atlatt.com](http://www.atlatt.com)

# Atlanta Attachment Company

## Confidential and Proprietary Information

The materials contained herein are confidential and proprietary information of Atlanta Attachment Company. In addition to any confidentiality and non-disclosure obligations that currently exist between you and Atlanta Attachment Company, your use of these materials serves as an acknowledgment of the confidential and proprietary nature of these materials and your duty not to make any unauthorized use or disclosure of these materials.

All materials contained herein are additionally protected by United States Copyright law and may not be used, disclosed, reproduced, distributed, published or sold without the express written consent of Atlanta Attachment Company, which consent may be withheld in Atlanta Attachment Company's sole discretion. You may not alter or remove any copyright, trademark or other notice from copies of these materials.

This equipment may be protected by one or more US and foreign patents.

For a complete list visit  
[atlatt.com/patents.php](http://atlatt.com/patents.php)

### IMPORTANT

**It is important to read and understand the information contained within this manual before attempting to operate the machine. Atlanta Attachment Co., Inc. shall not be held liable for damage resulting from misuse of the information presented within, and reserves the right to change the information contained within, without prior notification.**

Atlanta Attachment Company  
362 Industrial Park Drive  
Lawrenceville, Georgia 30045  
Phone:(770) 963-7369  
Fax:(770) 963-7641  
Email:sales@atlatt.com

## Table of Contents

Important Safety Instruction .....	5
Safety Equipment on the Machines .....	7
Protective Eyewear.....	8
Important Notices .....	9
Maintenance .....	11
Repair .....	12
A Word to the End User .....	13
Safety Precautions.....	13
1.1. Parts & Components .....	14
1.2. Technical Data .....	15
1.3. Footprint.....	15
1.4. Machine Identification Tag.....	16
1.5. Accessories .....	16
1.6. Types of Machines & Subclasses .....	17
1.7. Assembly.....	18
1.8. Switched On .....	19
1.9. Provisional Storage.....	19
2.    OPERATION .....	20
2.1. Individual Components.....	20
1. Sewing Head .....	20
2. Control Panel .....	21
3. Release Clutch Button .....	21
4. Knee Switch .....	21
5. Carriage .....	21
6. Car Blocker.....	22
7. Table .....	22
8. Roll Holder .....	22
9. Turn Off Button .....	22
10. Power Button.....	22
11. Stop Button.....	22
12. Clutch Button.....	22
13. Start Button .....	23
14. Head Tilt .....	23
15. Elevation Table .....	23

2.2. Preparation for Sewing.....	24
1. Change of Needle .....	24
2. Upper Threading.....	24
3. Lower Threading.....	24
4. Thread Tension Adjustment .....	25
5. Threading the Tape.....	26
2.3. Sewing .....	27
2.4. Maintenance.....	27
1. General Security Instructions .....	28
2. Preparation.....	28
3. Preventive Maintenance Schedules Day – Week – Monthly --Annually .....	28
4. Lubrication Sewing Head Daily .....	29
3. SERVICE .....	30
3.1. Lockout / Tag out Program.....	31
3.2. Mechanical Adjustments .....	32
1. Table Adjustment .....	32
2. Carriage Adjustment.....	34
3. Sewing Head Adjustments.....	34
4. Tape Edge Folders .....	44
3.3. Electrical Adjustments.....	44
1. Ground.....	45
2. Master Switch.....	45
3. Table Motor Contactor .....	45
4. Electric Transmission Ring .....	45
5. Main Distribution Box.....	47
6. Motors .....	49
7. Knee Pad.....	52
8. Electronic Clutch.....	54
3.4. Maintenance.....	55
Maintenance of the Carriage Drive Reduction Box.....	55
Preventative Maintenance Schedule Daily (8 Hours).....	56
Preventative Maintenance Schedule Weekly (40 Hours).....	57
Preventative Maintenance Schedule Monthly (160 Hours).....	58
1. General Security Instructions .....	60
2. Preparation.....	60

3.5. Troubleshooting .....	61
3.6. High Mortality Kit. ....	63
3.7. Training.....	64
Singer® 300UX6 Assembly Drawings & Parts Lists .....	65
Upper Shaft Assembly .....	66
Front Assembly Sewing Arm.....	68
External Parts Sewing Arm #1 .....	70
Lower Shaft Assembly .....	72
Front Assembly Sewing Bed .....	74
Cross Shaft in Sewing Bed .....	76
External Parts Sewing Arm #2 .....	78
External Parts Sewing Arm #3 .....	80
External Parts Sewing Arm #4 .....	82
External Parts Sewing Arm #5 .....	84
Accessories .....	86
COLUMN ASSEMBLY / ADJUSTMENT INSTRUCTIONS .....	87
Assembly Drawings & Parts Lists.....	88
11345-2C Tape Edge Workstation.....	89
SIN-300UX6A Tape Edge Head (11345-2B and 2C) .....	90
SSIN-300UX6M Modified Sewing Head Assembly.....	91
1345-025 Tape Roll Holder.....	94
11345-2CP Tape Edge Workstation.....	95
1345170 Sewing Head, Top Carriage Assembly .....	96
11345-2CQSJ Lock Stitch, Queen, Tape Edge Workstation .....	97
1345440 Tape Edge Head, Juki LS1341 Lock stitch .....	98
13453000SA Carriage Assembly, Short, Lock Stitch .....	100
13453500F Gear Box Assembly .....	102
13453300S Top Carriage Assembly .....	104
13459300 Control Button Panel .....	106
11345-2CTSJ Lock Stitch, Twin. Tape Edge Workstation.....	107
13452500TA Frame Lift Table, Twin,.....	108
13451000TA Base Lift Table, Twin .....	109
Obsolete, Revisions or Replacement Assemblies.....	110
13452500A Frame Lift Tablet – Revision 11.....	111
13451000 Lift Table Base Assembly .....	112

13459500 Control Box.....	113
1345-2AWD Wiring Diagram .....	114
1345485 Frame Lift Table – Revision 11 .....	115
1345490 Base, Lift Table .....	116
13452500A Frame Lift Table – Revision 12 .....	117
13451000A Lift Table Base Assembly.....	118
13452000D Column Lift Assembly.....	119
1345495 Control Box.....	121
1345-2CWD Wiring Diagram .....	122
1345474 Carriage Assembly .....	123
1345475 Carriage Control Box .....	125
1345480 Electrical Panel .....	127
1345482 Control Button Panel.....	128
13453300A Top Carriage Assembly.....	129
13453400A Carriage Guide Assembly .....	131
13453390A Motor Assembly.....	136
13453500E Gear Box Assembly.....	137
13453800 Gear Lock Assembly.....	139
Attachment Company (AAC) Statement of Warranty.....	140
Notes: .....	142
3.8. INDEX.....	143

## Important Safety Instruction



This part of the Instruction Material is provided for the safe use of your equipment. It contains important information to help work safely with the unit and describes the dangers inherent in machinery. Some of these dangers are obvious, while others are less evident.

## Mandatory Information

All persons operating and/or working on the 1345-2B Tape Edge Machine should read and understand all parts of the Safety Instructions. This applies, in particular, for persons who only operate and/or work on the unit occasionally (e.g. for maintenance and repair). Persons who have difficulty reading must receive particularly thorough instruction.

## Scope of the Instruction Material

- The Instruction Material comprises:
- Safety information
- Operator Instructions
- Electrical and Pneumatic diagrams

And may also include.

- A list of recommended spare parts
- Instruction Manual(s) for components made by other manufacturers.
- The layout and installation diagram containing information for installation.

## Intended Use

Our machines are designed and built in line with the state of the art and the accepted safety rules. However, all machines may endanger the life and limb of their users and/or third parties and be damaged or cause damage to other property, particularly if they are operated incorrectly or used for purposes other than those specified in the Instruction Manual.

## Exclusion of Misuse

The machine and non-conforming uses include, for example, using the equipment for something other than it was designed for, as well as operation without duly installed safety equipment. The risk rests exclusively with the end user.



Conforming use of the machine includes compliance with the technical data, information and regulations in all parts of the complete Instruction Material, as well as compliance with the maintenance regulations. All local safety and accident prevention regulations must also be observed.

## Liability

## Service Instructions

---

The machine should only be operated when in perfect working order, with due regard for safety and the potential dangers, as well as in accordance with the Instruction Material. Faults and malfunctions capable of impairing safety should be remedied immediately. We cannot accept any liability for personal injury or property damage due to operator errors or non-compliance with the safety instructions contained in this booklet. The risk rests exclusively with the end user.

The Instruction Material should always be kept near the machine so that it is accessible to all concerned.

The local, general, statutory, and other binding regulations on accident prevention and environmental protection must also be observed in addition to the Instruction Material. The operating staff must be instructed accordingly. This obligation also includes the handling of dangerous substances and provision/use of personal protective equipment.

The Instruction Material should be supplemented by instructions, including supervisory and notification duties with due regard for special operational features, such as the organization of work, work sequences, the personnel deployed, etc.

The personnel's awareness of the dangers and compliance with the safety regulations should be checked at irregular intervals.

## Choice and Qualification of Personnel

Ensure that work on the machine is only carried out by reliable persons who have been appropriately trained for such work - either within the company, by our field staff or at our office - and who have not only been duly appointed and authorized but are also fully familiar with the local regulations. Work on the machine should only be carried out by skilled personnel, under the management and supervision of a duly qualified engineer.

This not only applies when the machine is used for production, but also for special work associated with its operation (start-up and maintenance), especially when it concerns work on the hydraulic or electrical systems, as well as on the software/serial bus system.

## Training

Everyone working on or with the machine should be duly trained and informed about the correct use of the safety equipment, the foreseeable dangers which may arise during operation of the machine and the safety precautions to be taken. In addition, the personnel should be instructed to check all safety mechanisms at regular intervals.

## Responsibilities

Clearly define exactly who is responsible for operating, setting-up, servicing and repairing the machine. Define the responsibilities of the machine operator and authorize him to refuse any instructions by third parties if they run contrary to the machine's safety. This applies for the operators of machines linked to other equipment. Persons receiving training of any kind may only work on or with the machine under the constant supervision of an experienced operator. Note the minimum age limits permitted by law.

## A Word to the Operator

## Service Instructions

---

The greatest danger inherent in our machines is that of fingers, hands or loose clothing being drawn into a machine by live, coasting or rotating tools or assemblies or of being cut by sharp tools or burned by hot elements.

### **ALWAYS BE CONSCIOUS OF THESE DANGERS!**

## Safety Equipment on the Machines

All machines are delivered with safety equipment, which shall not be removed or bypassed during operation.

The correct functioning of safety equipment on machines and systems should be checked every day and before every new shift starts, after maintenance and repair work, when starting up for the first time and when restarting (e.g. after prolonged shutdowns).

If safety equipment must be dismantled for setting-up, maintenance or repair work, such safety equipment shall be replaced and checked immediately upon completing the maintenance or repair work. All protective mechanisms shall be fitted and fully operational whenever the machine is at a standstill or if it has been shut down for a longer period.

## Damage

If any changes capable of impairing safety are observed in the machine or its mode of operation, such as malfunctions, faults or changes in the machine or tools, appropriate steps must be taken immediately, the machine switched off and a proper lockout tagout procedure followed. The machine should be examined for obvious damage and defects at least once per shift. Damage found shall be immediately remedied by a duly authorized person before resuming operation of machine.

The machine should only be operated when in perfect working order and when all protective mechanisms and safety equipment, such as detachable protective mechanisms, emergency STOP systems, etc. are in place and operational.

## Faults or Errors

The machine must be switched off and all moving or rotating parts allowed to come to a standstill and secured against accidental restart before starting to remedy any faults or errors.



### **Signs on the Machine**

Safety and danger signs on the machine should be observed and checked at regular intervals to ensure that they are complete and undamaged. They should be always clearly visible and legible.

#### **Clothing, Jewelry, Protective Equipment**

Long loose hair, loose-fitting clothes, gloves, and jewelry, including rings, should be avoided in order to avoid injuries due to being caught, drawn in and wound up inside the machine.

## Protective Eyewear

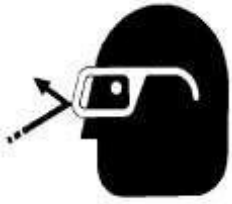

Protective eyewear that has been tested by the local authorities should be worn whenever there is a possibility of loose or flying objects or particles such as when cleaning the machine with compressed air.

## Tools

Always count the number of tools in your possession before starting work on the machine. This will allow you to check that no tools have been left behind inside the machine. Never leave a tool in the machine while working.

## Oils, Lubricants, Chemicals

Note the applicable safety regulations for the product used.

## No Smoking, Fire, Explosion Hazard

Smoking and open flame (e.g. welding work) should be prohibited in the production area due to the risk of fire and explosions.

## Workplace

A clear working area without any obstructions whatsoever is essential for safe operation of the machine. The floor should be level and clean, without any waste.

The workplace should be well lit, either by the general lighting or by local lights.

## Emergency STOP

The emergency STOP buttons bring all machine movements to a standstill. Make sure you know exactly where they are located and how they work. Try them out. Always ensure easy access to the nearest emergency STOP button while working on the machine.

## First Aid

1. From the danger zone. The decision of what to do and whether keep calm even when injured.
2. Clear the operator to seek additional assistance rests entirely with you, particularly if someone has been trapped.
3. Give First Aid. Special courses are offered by such organizations as the employers' liability insurance association. Your colleagues should be able to rely on you and vice versa.
4. Call an ambulance. Do you know the telephone numbers for the ambulance service, police and fire service?

## Important Notices

### Reporting and Fighting Fires

Read the instructions posted in the factory about reporting fires and the emergency exits. Make sure you know exactly where the fire extinguishers and sprinkler systems are located and how they are operated. Pass on the corresponding information to the firemen when they arrive. Ensure there are enough signs to avoid fire hazards.

The following fire extinguishers may be used:

- Dry powder extinguishers, ABC fire-extinguishing powder.
- Carbon dioxide fire extinguishers to DIN 14461 for electronic components. Great care must be exercised when using carbon dioxide fire extinguishers in confined, badly ventilated rooms (see DIN 14406 and 14270).

Isolate the machine from the power supply if a fire breaks out. Do not use water on burning electrical parts until it is certain that they have been completely disconnected from the power supply. Burning oils, lubricants, plastics, and coatings on the machine can give off gases and vapors that may be harmful to your health.

A qualified person should be consulted to repair the damage after a fire.

### Electrical Power Supply



Before undertaking any maintenance or repair work on the machine, switch off the electrical power to the machine at the main source and secure it with a padlock so that it cannot be switched on again without authorization.

In practice, this may mean that the technician, electrician, and operator all attach their own padlock to the master switch simultaneously so that they can carry out their work safely. Locking extension plates should be available for multiple locks if required. The primary purpose for a lockout/tagout procedure is to protect

workers from injury caused by unexpected energizing or start-up of equipment.

Energy sources (electrical/pneumatic/hydraulic, etc.) for the equipment shall be turned off or disconnected and the switches locked or labeled with a warning tag. It is the responsibility of the employer to establish control procedures. Follow lockout/tagout procedures before, setup and/or any service or maintenance work is performed, including lubrication, cleaning, or clearance of jams.

**Caution: The machine is still not completely de-energized even when the master switch is off.**

- Electricity - The machine is always isolated from the electrical power supply whenever the master switch has been switched off. However, this does not apply for the power supply in the control cabinet, nor for equipment that does not draw its power via the master switch.
- Pneumatic / hydraulic energy - Almost all our machines carry compressed air. In addition to switching off the master switch, the air supply must also be disconnected, and the machine checked to ensure it is

## Service Instructions

---

depressurized before starting any work on the machine; otherwise the machine may execute uncontrolled movements.

- Kinetic energy - Note that some motors or spindles, for example, may continue to run or coast run on after being switched off.
- Potential energy - Individual assemblies may need to be secured if necessary for repair work.

## Delivery of the Machine/Packaging

Note any markings on the packaging, such as weights, lifting points and special information. Avoid temperature fluctuations. Condensation may damage the machine.

## Transport Damage

The packaging and machine must immediately be examined for signs of damage in transit. Such damage must be reported to the shipper/transporter within the applicable time limits. Contact Atlanta Attachment Company and/or your transport insurer immediately, if signs of damage are visible. Never operate a damaged machine.

## Interim Storage

If the machine must be stored temporarily, it must be oiled or greased and stored in a dry place where it is protected from the weather to avoid damage. A corrosion-inhibiting coating should be applied if the machine must be stored for a longer period and additional precautions taken to avoid corrosion.

## Transporting the Machine

Disconnect the machine from all external connections and secure any loose assemblies or parts. Never step under a suspended load. When transporting the machine or assemblies in a crate, ensure that the ropes or arms of a forklift truck are positioned as close to the edge of the crate as possible. The center of gravity is not necessarily in the middle of the crate. Note the accident prevention regulations, safety instructions and local regulations governing transport of the machine and its assemblies.

Only use suitable transport vehicles, hoisting gear and load suspension devices that are in perfect working order and of adequate carrying capacity. Transport should only be entrusted to duly qualified personnel.

Never allow the straps to rest against the machine enclosure and never push or pull sensitive parts of the machine. Ensure that the load is always properly secured. Before or immediately after loading the machine, secure it properly and affix corresponding warnings.

All transport guards and lifting devices must be removed before the machine is started up again. Any parts that are to be removed for transport must be carefully refitted and secured before the machine is started up again.

## Workplace Environment

Our machines are designed for use in enclosed rooms: Permissible ambient temperature approx. 5 - 40 °C (40 - 104 °F). Malfunctions of the control systems and uncontrolled machine movements may occur at temperatures outside this range.

## Service Instructions

---

Protect against climatic influences, such as electrostatic charges, lightning strikes, hail, storm damage, high humidity, salinity of the air in coastal regions.

Protect against influences from the surroundings: no structure-borne vibrations, no grinding dust, or chemical vapors.

Protect against unauthorized access.

Ensure that the machine and accessories are set up in a stable position.

Ensure easy access for operation and maintenance (Instruction Manual and layout diagram); also verify that the floor is strong enough to carry the weight of the machine.

## Local Regulations

Particular attention must be paid to local and statutory regulations, etc. when installing machines and the plant (e.g. with regard to the specified escape routes). Note the safety zones in relation to adjacent machines.

## Maintenance

### General Safety Instructions

The machine shall be switched off, come to a standstill, and be secured so that it cannot be switched on again inadvertently before starting any maintenance work whatsoever. Use proper lockout/tagout procedures to secure the machine against inadvertent startup.

Remove any oil, grease, dirt and waste from the machine, particularly from the connections and screws, when starting the maintenance and/or repair work. Do not use any corrosive-cleaning agents. Use lint free rags.

Retighten all screw connections that must be loosened for the maintenance and repair work. Any safety mechanisms that must be dismantled for setting-up, maintenance or repair purposes must be refitted and checked immediately after completing the work.

### Maintenance, Care, Adjustment

The activities and intervals specified in the Instruction Manual for carrying out adjustments, maintenance and inspections must be observed, and parts replaced as specified.

All hydraulic and pneumatic lines should be examined for leaks, loose connections, rubbing and damage whenever the machine is serviced. Any defects found must be remedied immediately.

### Waste, Disassembly, Disposal

Waste products should be cleared from the machine as soon as possible as not to create a fire hazard. Ensure that fuels and operating lubricants, as well as replacement parts are disposed of in a safe and ecologically acceptable manner. Note the local regulations on pollution control.

When scrapping (disassembling) the machine and its assemblies, ensure that these materials are disposed of safely. Either commission a specialist company familiar with the local regulations or note the local regulations when disposing of these materials yourself. Materials should be sorted properly.

.

.

## Repair

### Replacement Parts

We cannot accept any liability whatsoever for damage due to the use of parts made by other manufacturers or due to unqualified repair or modification of the machine.

### Repair, Electrical

The power supply must be switched off (master switch off) and secured so that it cannot be switched on again inadvertently before starting any work on live parts.

Those parts of the machine and plant on which inspection, maintenance or repair work is to be carried out must be isolated from the power supply, if specified. The isolated parts must first be checked to determine that they are truly de-energized before being grounded and short-circuited. Adjacent live parts must also be isolated.

The protective measures implemented (e.g. grounding resistance) must be tested before restarting the machine after all assembly or repair work on electric parts.

Signal generators (limit switches) and other electrical parts on the safety mechanisms must not be removed or bypassed. Only use original fuses or circuit overloads with the specified current rating. The machine must be switched off immediately if a fault develops in the electrical power supply.

The electrical equipment of our machines must be checked at regular intervals and any defects found must be remedied immediately.

If it is necessary to carry out work on live parts, a second person should be on hand to operate the emergency OFF switch or master switch with voltage release in the event of an emergency. The working area should be cordoned off and marked by a warning sign. Only use electrically insulated tools.

### Ventilation/Hazardous Gases

It is the end user's responsibility to ensure adequate ventilation is provided to exhaust any and all noxious or hazardous gases that may be present in the working environment.

### Hydraulic and Pneumatic Systems

Work on hydraulic or pneumatic equipment shall only be carried out by persons with training, knowledge, and experience of hydraulic systems. Pressure lines shall be depressurized before starting any repair work.

### General Liability

## Service Instructions

---

Liability for machine damage and personal injury is extinguished completely if any unauthorized conversions or modifications are undertaken. The machine must not be modified, enlarged, or converted in any way capable of affecting safety without the manufacturer's prior approval.

## Starting Machine Movements

Read the Instruction Manual carefully to establish which keys and functions start machine movements.

## A Word to the End User

The end user has sole responsibility to enforce the use of safety procedures and guards on the machine. Any other safety devices or procedures due to local regulations should be retrofitted in accordance to these regulations and/or the EC Directive on the safety of machines.

Operator's position must always be readily accessible. Escape routes must always be kept clear and safety areas should be identified.

## Safety Precautions

Safety should be a constant concern for everyone. Always be careful when working with this equipment. While normal safety precautions were taken in the design and manufacture of this equipment, there are some potential safety hazards.

**Everyone involved with the operation and maintenance of this equipment should read and follow the instructions in this manual.**

**Operate the equipment only as stated in this manual. Incorrect use could cause damage to the equipment or personal injury.**

**It is the owner's responsibility to make certain that the operator reads and understands this manual before operating this equipment. It is also the owner's responsibility to make certain that the operator is a qualified and physically able individual, properly trained in the operation of this equipment.**

Specific safety warning decals are located on the equipment near the immediate areas of potential hazards. These decals should not be removed or obliterated. Replace them if they become non-readable.

- ALWAYS keep safety shields and covers in place, except for servicing.
- ALWAYS operate equipment in daylight or with adequate working lights.
- Follow daily and weekly checklists, making sure hoses are tightly secured and bolts are tightened.
- ALWAYS watch and avoid holes or deep depressions.
- ALWAYS wear adequate eye protection when servicing the hydraulic system and battery.
- NEVER operate a poorly maintained machine.
- NEVER allow persons to operate this machine without proper instruction.
- NEVER put hands or feet under any part of the machine while it is running.
- NEVER attempt to make any adjustments or repairs to the machine while running. Repairs or maintenance should be performed by trained personnel only.

## Service Instructions

- NEVER work under the machine unless it is safely supported with adequate mechanical stands, blocks or a hoist and blocks.
- NEVER touch hot parts of machine.

## 1. INSTALLATION

**NOTE:** It is important that the machine technician read this manual and be familiar with all the safety functions and concerns of the unit before installing and operating.

### 1.1. Parts & Components

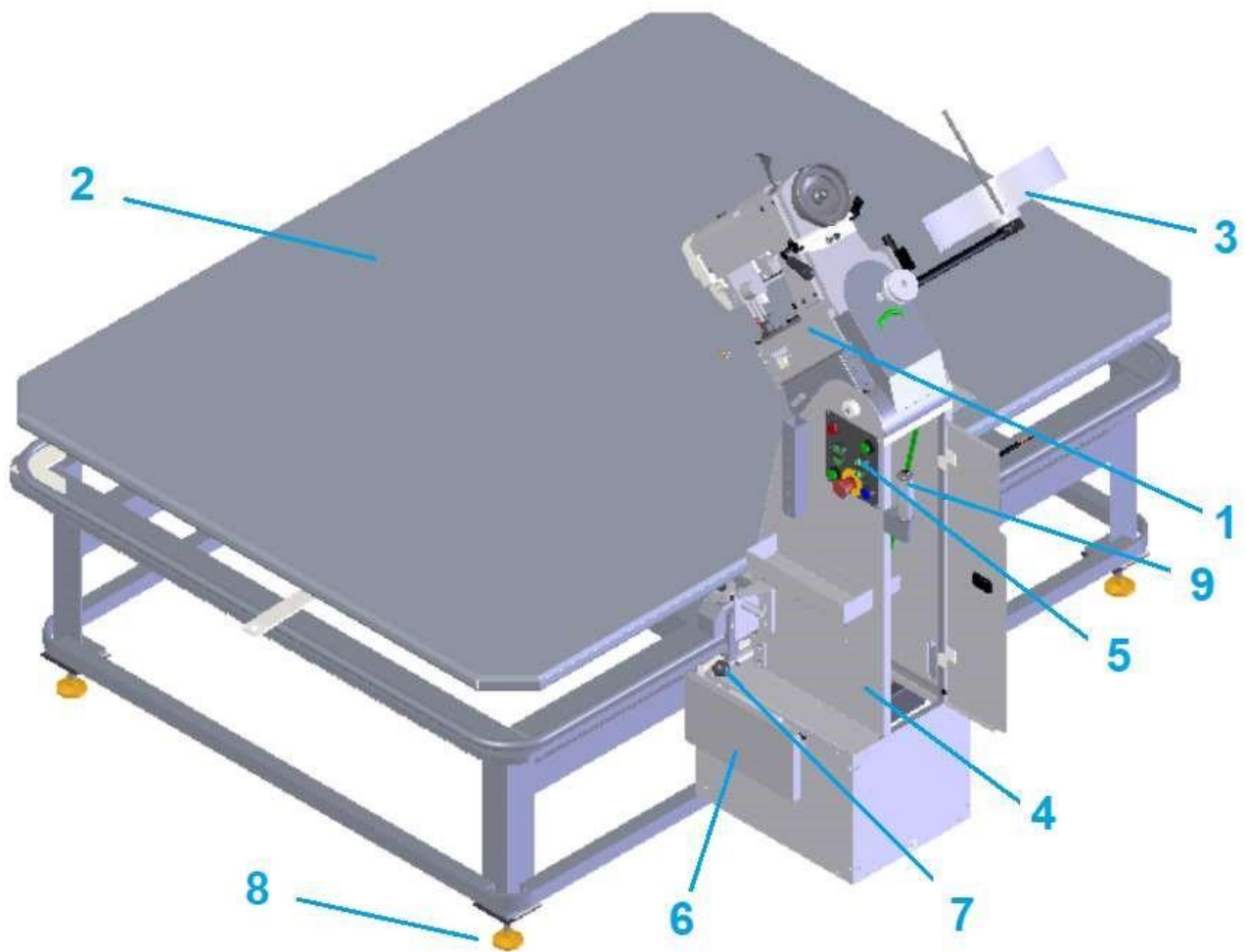

1.- Sewing Head	6.- Speed Control
2.- Table	7.- Locking Lever
3.- Roll Holder	8.- Leg
4.- Carriage	9.- Activating Lever
5.- Control Panel	

## 1.2. Technical Data



Description	Unit	Cost
Max Sewing Speed	Rpm	3.000
Sewing Head Model		Singer 300UX6
Factory Preset Speed	Rpm	2.700
Maximum Stitch Length	PPP	4
Needle System		SN62X5924
Needle Size		24/180
Weight of the Material		MEDIUM/ HEAVY
Max Presser Foot lift	Inches	7/16
Voltage	V/Ph/Hz	220HZ 3PH 60HZ
Current	Amps	5
Height Range of Beds	Inches	4 to 22
Table Travel	Inches	25 to 38
Actuator Model		Motion 85200
Actuator Capacity	Lbs	1.000
Frictional Load		25%
Board and Frame Weight	Lbs	175
Weight of the Column	Lbs	25
Friction of the Table	Lbs	500-600
Shipping Weight	Lbs	2.100
Shipping Dimensions (w / l / h)	Inches	65 x 106 x 65
Pieces per Hour		15 (2 Cintas)

## 1.3. Footprint

The footprint of the machine is 102 "x 120" (258 x 304 cm)

Leave enough free space around to be able to open all doors and have access for maintenance.

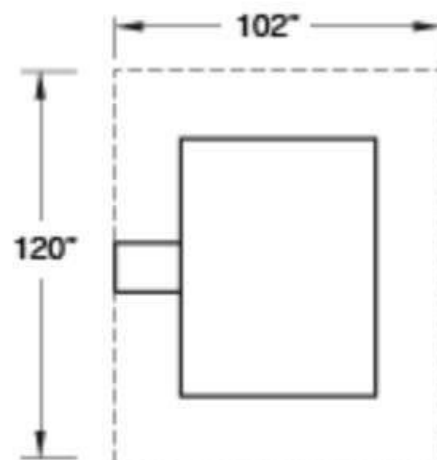

### 1.4. Machine Identification Tag

The identification of the machine is located on the top of the table behind the sewing head. Its content is the machine class and the Serial Number.

Ex: 218427031707

The serial number is divided as follows:

The first number identifies the order number, 218427

The next number the month of manufacture, (03)

The next number the year of manufacture, (17)

Following a correlative number, 07



### 1.5. Accessories

Part Number	Description	Drawing
1345-KIT12	Double Tape Kit	
11345-KIT15	Adjustable Corner Radio Kit	
1375S88N	Vibrating Binder	

## 1.6. Types of Machines & Subclasses

Numero de Parte	Description	TYPE		INCLINATION		ELECTRICAL		MOTOR		LEVER		BEDS		TABLE				SEWING HEAD		
		Standard	Personalizadas	Manual	Electrica	Simple	Dual	Manual	Electrica	4" to 22"	4" to 30"	Twin	Full	Queen	King	300UX6	Pfaff 5625	Typical	Juki B1341	C1300
11345-2B	Tape Edge Workstation, Singer 300UX6, Clutch Carriage	X			X	X				X		X				X				
11345-2BP	Tape Edge Workstation, Pfaff 5625 WF	X			X	X				X		X				X				
11345-3P	TAPE EDGE WORKSTATION, PFAFF 5625, DUAL SPEED, POWER GLIDE	X			X	X			X		X					X				
11345-3C	Tape Edge Workstation. 300UX6 Singer, Servo drive, Power Glide Carriage	X			X	X			X		X					X				
11345-4C	Tape Edge Workstation, 300UX6 Singer, Servo Drive, Power Glide Carriage & Power Sew	X			X	X			X		X					X				
11345-4P	Tape Edge Workstation, Pfaff 5625, Dual Speed, Column Lift	X			X	X			X		X					X				
11345-5A	Tape Edge Workstation. 300UX6 Singer, Servo drive, Clutch Carriage	X			X	X			X		X					X				
11345-5P	Tape Edge Workstation, Pfaff 5625, Servo Drive, Clutch Carriage	X			X	X			X		X					X				
11345-6A	Tape Edge Workstation. 300UX6 Singer chain stitch walking foot Sewing Head Sewing	X			X	X			X		X					X				
11345-6P	Tape Edge Workstation. SPF5625-657-02M chain stitch walking foot Sewing Head Sew	X			X	X			X		X					X				
<b>Personalizadas</b>																				
11345-2BF	TAPE EDGE MACHINE, FULL VARI SPEED, POWER TILT	X			X	X			X		X					X				
11345-2BPK	Tape Edge Workstation, King Size, Pfaff 5625 WF	X			X	X			X		X					X				
11345-2BQSJ	TAPE EDGE MACHINE, QUEEN, SHORT, JUKI LOCKSTITCH	X			X	X			X		X					X				
11345-2BT	TAPE EDGE MACHINE, TWIN VARI SPEED, POWER TILT	X			X	X			X		X					X				
11345-2BTSJ	TAPE EDGE MACHINE, TWIN, SHORT, JUKI LOCKSTITCH	X			X	X			X		X					X				
11345-2ET	TAPE EDGE MACHINE, ECO VARI SPEED, POWER TILT	X			X	X			X		X					X				
11345-3BK	TAPE EDGE MACHINE, KING DUAL SPEED, POWER GLIDE	X			X	X			X		X					X				
11345-3ET	TAPE EDGE MACHINE DUAL SPEED, PWR GLIDE, TYP	X			X	X			X		X					X				
11345-5AK	Tape Edge Workstation. King size, 300UX6 Singer, Servo drive, Clutch Carriage	X			X	X			X		X					X				
11345-5PK	Tape Edge Workstation, King Size, Pfaff 5625, Servo Drive, Clutch Carriage	X			X	X			X		X					X				
11345-6S	TAPE EDGE SHORT CARRIAGE	X			X	X			X		X					X				
11345-6SP	TAPE EDGE MACHINE, PFAFF, SHORT CARRIAGE	X			X	X			X		X					X				
<b>Sin Cabezal</b>																				
11345-2BNH	Tape Edge Machine, No Head. Powered sewing head tilt, Variable Speed				X	X			X		X					X				
11345-3BNH	TAPE EDGE MACHINE, NO HEAD DUAL SPEED, POWER GLIDE				X	X			X		X					X				
11345-5ANH	TAPE EDGE MACHINE, NO HEAD DUAL SPEED CLUTCH				X	X			X		X					X				

## Service Instructions

### 1.7. Assembly

- Remove all shipping belts from the machine.
- Inspect the machine for any damage that may have occurred during shipment. If damage is found, report this immediately to your supervisor. Document the damage and provide details and photographs.
  
- Place the machine in the desired location on a reasonably level and stable floor. To transport it use the forklift supports # 1.
- Make sure there is sufficient lighting over the machine. Remove all packing material.
- Aplique con una toalla limpia una capa ligera de aceite a todas las partes metálicas para evitar la corrosión futura.



#### 1. Sewing Head

The sewing head (1) has been removed for shipment. Install the sewing head and attach the green tension belt (2) taking care that it moves inside the two upper guide pulleys (3).

The belt will need to be turned 90 degrees (4) clockwise to reach the lower engine. If the rotation is inverse the head will rotate in the opposite direction.

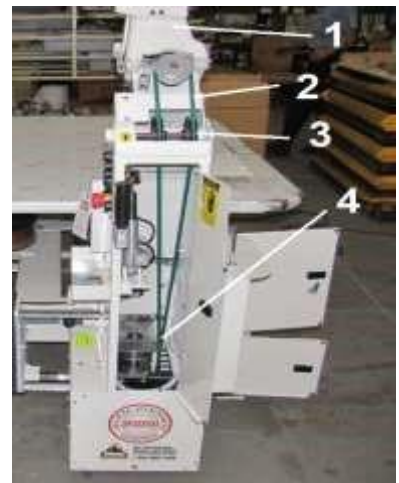

#### 2. V Belt

Check the tension of the motor belts. If it is too loose the car can stop on its way.



#### 3. Sewing Head Lubrication

Follow the lubrication procedures of the sewing head. (ISO Viscosity Grade 22 part #SO)

Turn the Hand wheel head wheel manually and check the freedom of movement.



## Service Instructions

### 4. Tape Roll Holder

Install the tape roll holder



### 5. Power Connection

Connect the power cord to 208-230 Vac, single-phase. 5 Amps. Lower table wiring meets UL standards.

**NOTE:** It is important that the green wire is connected to ground



### 6. Control Box

Make sure that the protection switch 1 is in the on position



### 1.8. Switched On

Turn half a turn to the big red Shutdown button on the control panel. Press the Green Power button located in the lower left. A light on the red stop button located on the top left will turn on.



### 1.9. Provisional Storage

If the machine must be stored temporarily, it must be oiled or greased and stored in a dry place where it is protected from the weather to prevent damage. A corrosion inhibitor coating should be applied if the machine should be stored for a longer period and additional precautions should be taken to prevent corrosion. Do not place anything on the table.

## 2. OPERATION

Note: It is important that the operator of the machine read this manual and be familiar with all the functions and safety concerns of the unit before operating.

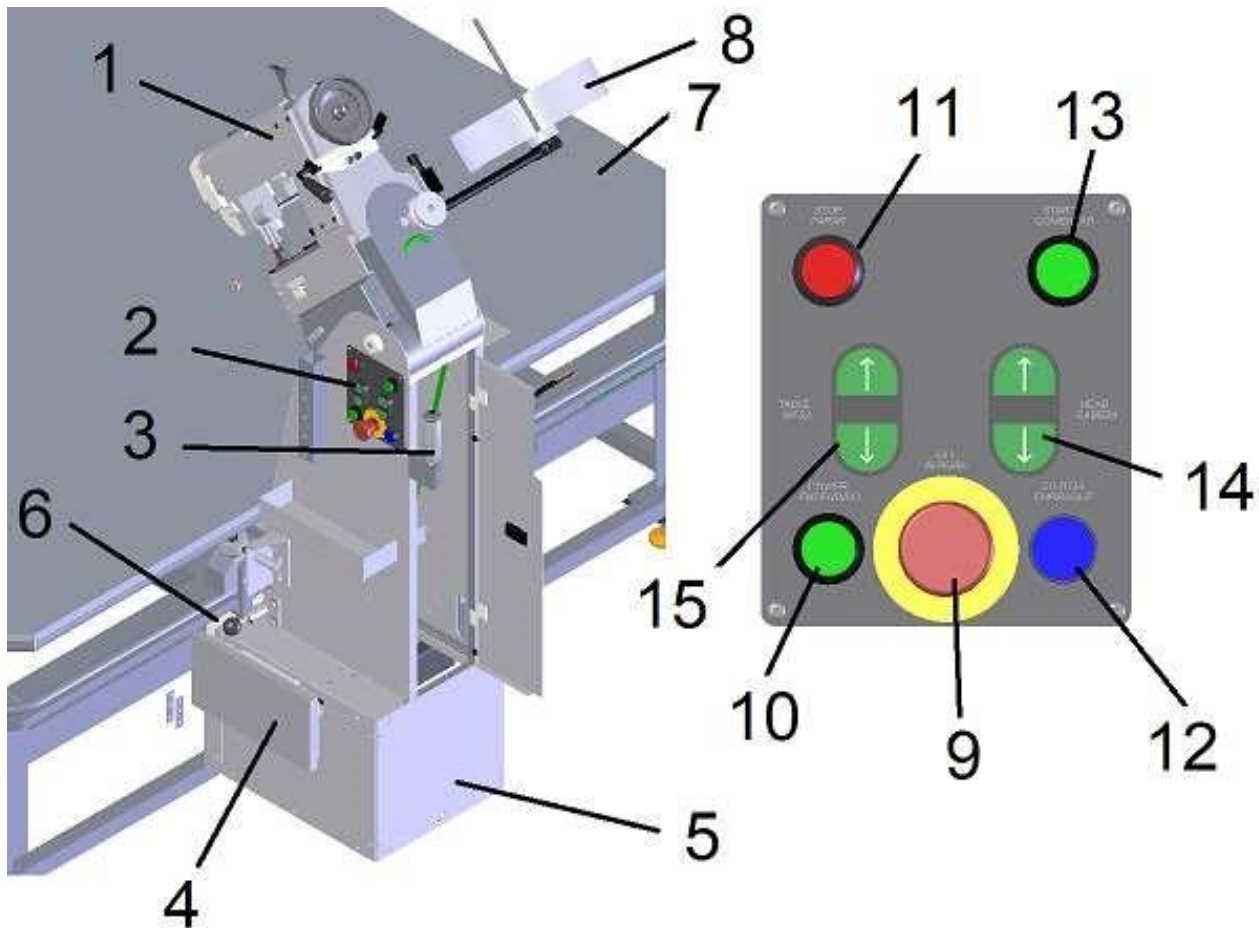

1.- Sewing Head	7.- Table	13.- Start Button
2.- Control Panel	8.- Roll Holder	14 – Head Tilt
3.- Disengage Button	9.- Turn Off Button	15.- Table Elevation
4.- Knee Switch	10.- Turn On Button	
5.- Carriage	11.- Stop Button	
6.- Carriage Blocker	12.- Clutch Button	

### 2.1. Individual Components

#### 1. Sewing Head

The 1345-2B unit designed for tape edge borders is supplied with a sewing head Model SSIN330UX6. Threading, curb, needles, etc. is explained later in this manual.



## Service Instructions

### 2. Control Panel

It is located on the transport carriage easily accessible to the operator. From it all the electrical operations of the machine are controlled. Details of the buttons and functions are on the bottom.

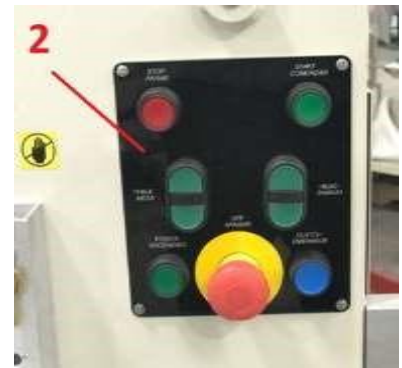

### 3. Release Clutch Button

This button has the function of deactivating the clutch, releasing the sewing carriage. With the button pressed it is possible to manually move the carriage to the desired position.

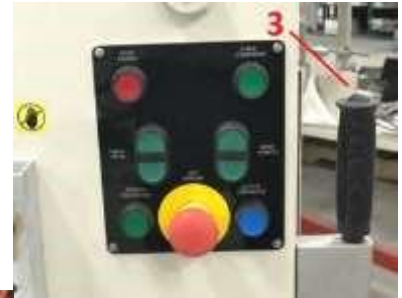

### 4. Knee Switch

The function of this switch is to control sewing mode. When touching with the advance. When releasing it, the car



the carriage feed in knee the car stops its continues its movement.

### 5. Carriage

It is the column that contains the sewing head and the main motor. It is mounted on two pulleys that run around the table completely.



## Service Instructions

### 6. Car Blocker

This lever has the function of locking the carriage in a fixed position. It is used for transport and to sew in a static way. In normal operation you must keep the car released.



### 7. Table

It is responsible for supporting the mattress during the binding operation. There are several measures available. Normally the measure is for Queen Mattresses. It is adjustable in height electronically through a button on the control panel.



### 8. Roll Holder

It is used to place the rolls of tapes. It has a pre-tensioning system that facilitates the sewing of the tape on the mattress. There is a double roll option to facilitate the use of two different types of tapes.



### 9. Turn Off Button

Its function is to energize the control panel. When pressed it locks and it will be necessary to turn it a quarter of a turn so that it is released. In the blocking position, the control panel cannot be energized.

**Caution: Unlocking the red button and pressing the green button will turn on the machine**

### 10. Power Button

Pressing it energizes the machine. The red button (11) lights up indicating that the machine is on. If the Off button (9) is blocked the red button (11) will not light up.

### 11. Stop Button

When powering the machine through the button (10), this button lights up. Pressing it disconnects the Start button and de-energizes the car.

### 12. Clutch Button

Its function is to deactivate the clutch. This will free the car to facilitate its movement.

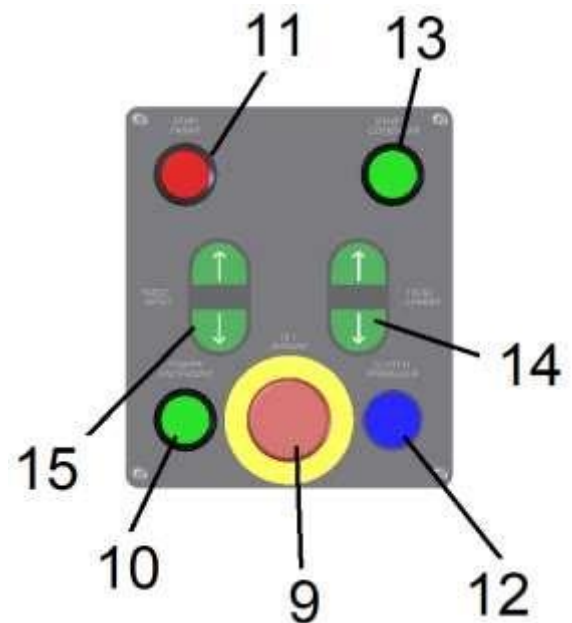

## Service Instructions

---

### 13. Start Button

Pressing the green light of the button turns on and the car engine energizes, starting the sewing cycle.

### 14. Head Tilt

Its function is to tilt the sewing head to facilitate the stitching of the mattress.

### 15. Elevation Table

Its function is to raise or lower the table at the height of the sewing needle. The table is adjustable from 25 "to 38" giving the operator a comfortable height of operation to work mattresses from 4 "to 22" (10cm to 56 cm)



## 2.2. Preparation for Sewing

**NOTE:** Please follow all safety procedures; it is recommended to turn off the machine.

### 1. Change of Needle

Turn the pulley of the machine towards the operator until the needle bar is at its highest point. Loosen the needle pressure screw.

Insert the needle into the bar and the needle clamp; make sure that the recesses of the needles are facing to the left. Refer to fig. Annex

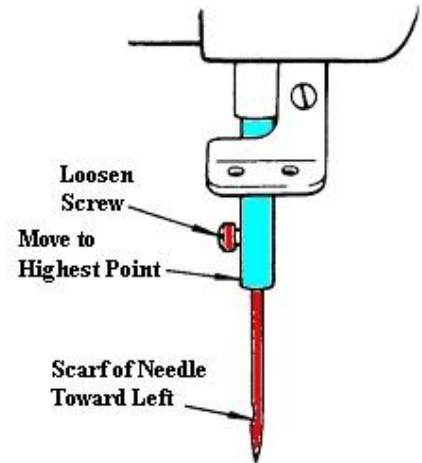

### Needle System SN62X8524

### 2. Upper Threading

Either left twist or right twist thread may be used in the needles and Loopers. Rough or uneven thread or thread which passes through the needle eye with difficulty will interfere with successful operation of the machine.



Turn the machine pulley over toward the operator until the needle bar is at its highest point. Pass the thread from the unwinder through the threading points indicated in Fig. 7. Draw approximately two inches of thread through the needle eye with which to start sewing. Make certain that each thread passes through the thread tension device.

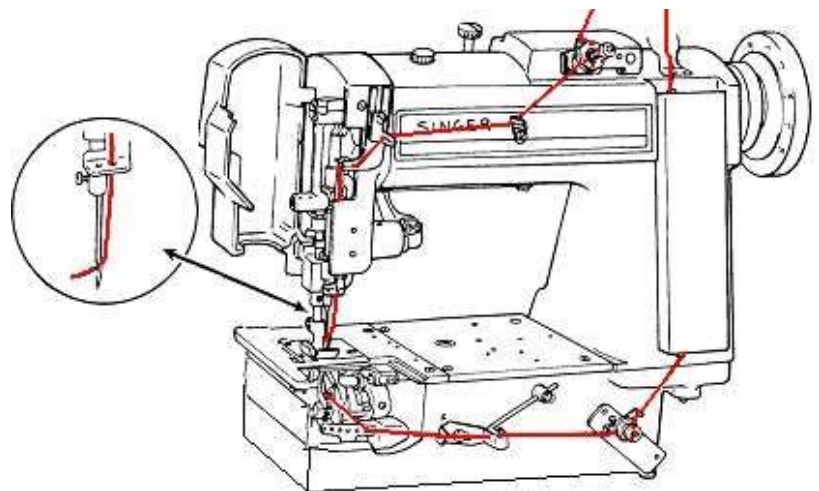

Fig. 7

### 3. Lower Threading

Open the front table section, remove the bed slide and turn the machine pulley over toward the operator until the needle bar is at its highest point.

## Service Instructions

Move the looper throw-out gear locking plunger rod and looper throw-out rack rod, Fig.7, out as far as possible. This will place Loopers in position for easier threading and prevent accidental operation of machine until Loopers are returned to sewing position.

Pass the thread from the unwinder through the threading points as indicated. Draw approximately two inches of thread through the looper eye with which to start sewing.

### 4. Thread Tension Adjustment

Tension on the thread should be as light as possible while still sufficient to set the stitch correctly in material.

#### Needle Thread Tension

To regulate the needle thread tension, turn the thumb screw indicated in Fig. 8 as may be required

**Note:** Regulate the needle thread tension only when the presser foot is down.

#### Looper Thread Tension

To regulate the looper thread tension, turn the thumb screws as indicated in Fig. 9 as may be required.

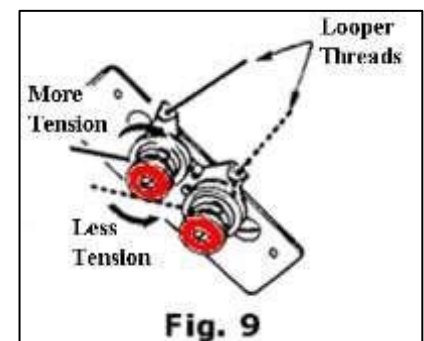
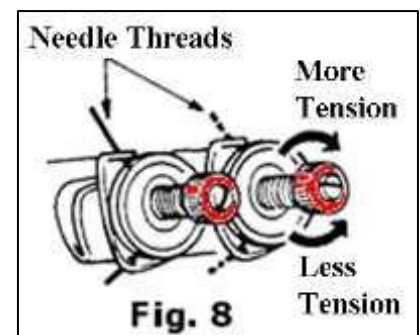
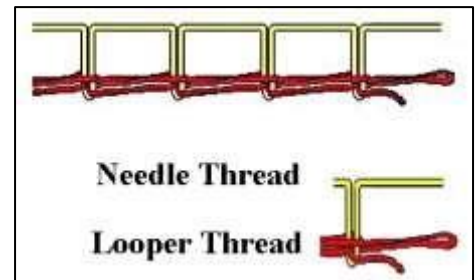
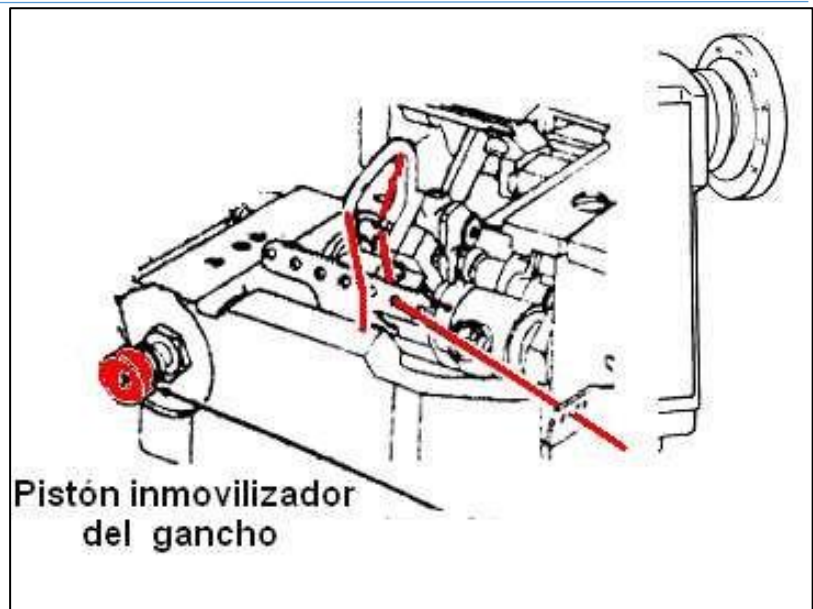

## Service Instructions

### 5. Threading the Tape.

- a. Place the roll of tape in the roll holder.
- b. Thread the tape through the tape tensioner.
- c. Use the pre-tensioning fingers if necessary.
- d. Cut the end of the tape at an angle and thread the fabric folder.
- e. Lift the fabric presser using the lever lift presser foot.
- f. Place the tape under the presser foot and lower the lever. The machine is ready to sew.



## 2.3. Sewing

- a. Place a mattress on the table. Press the table height button (15) until the needle is level with the edge of the mattress. Tilt the head if necessary, with the head tilt button (14)



- b. Move the mattress closer to the sewing machine. Lift the presser foot and place the mattress cover and the edge inside the edging tape.



- c. Lower the presser foot. Turn the Turn off button. (9) Press the power button (10). Press the knee activator (4). Press the start button (13). Slowly release the knee activator, the carriage will begin to move, and the machine will begin to sew.



- d. To stop the movement of the head presses the knee activator. Continue sewing through the perimeter of the mattress.



- e. Once the seam start has been reached, stop the machine with the knee brace and remove the fabric folder. Cut the tape and fold it manually. Release the knee activator and continue sewing to secure the remaining tape. Press the Stop button (11), move the needle to its upper position, lift the presser foot, cut the threads, and finally remove the mattress.



## 2.4. Maintenance

It is important that the operator of the machine read this manual and be familiar with all the functions and safety concerns of the unit before operating.

## Service Instructions

---

### 1. General Security Instructions

Maintenance should only be carried out by trained and qualified personnel. Turn off power, pneumatics, etc. before carrying out any maintenance or repair work, of the machine from the main source and secure it with a padlock so that it cannot be turned on again without authorization. See Lockout / Tag out Procedures.

- Always use the appropriate safety equipment when operating or performing maintenance on any equipment.
- All recommended maintenance is for a single shift schedule; adjust as needed for a multishift operation.
- The equipment must not be used for purposes other than those designed or specified.
- The machine must be switched off, stopped, and secured so that it cannot be switched on again inadvertently before starting any maintenance work.
- Use proper locking / labeling procedures to ensure the machine is inadvertently started.
- Remove any oil, grease, dirt, and waste from the machine, especially the connections and screws, when starting the maintenance and / or repair work.
- Do not use corrosive cleaning agents.
- Use lint-free cloths.
- Retighten all screw connections that must be loosened for maintenance and repair work.
- All safety mechanisms that must be disassembled for installation, maintenance or repair must be repaired and verified immediately after completion of work.

### 2. Preparation

- Turn off the machine.
- Open all the covers of the machine and the car.



### 3. Preventive Maintenance Schedules Day – Week – Monthly --Annually

See Printable sheets in Service Section shown as 3.4 Maintenance of this Manual

#### 4. Lubrication Sewing Head Daily

The 300U class machines have a semi-automatic lubrication system consisting of a hollow shaft in the arm and a hollow shaft in the bed that act as oil reservoirs. The oil is distributed to all the main bearings by centrifugal force through the small channels in the shafts when the machine is in operation.

Manual lubrication is also necessary to lubricate other moving parts that do not lubricate in the tanks.

The user must turn off the unit and lubricate all the red spots of the machine using SAE220 nondetergent type oil, frequently once a day before starting the operation.

See the following figures to verify the position of the holes and points to be lubricated in the fusion.

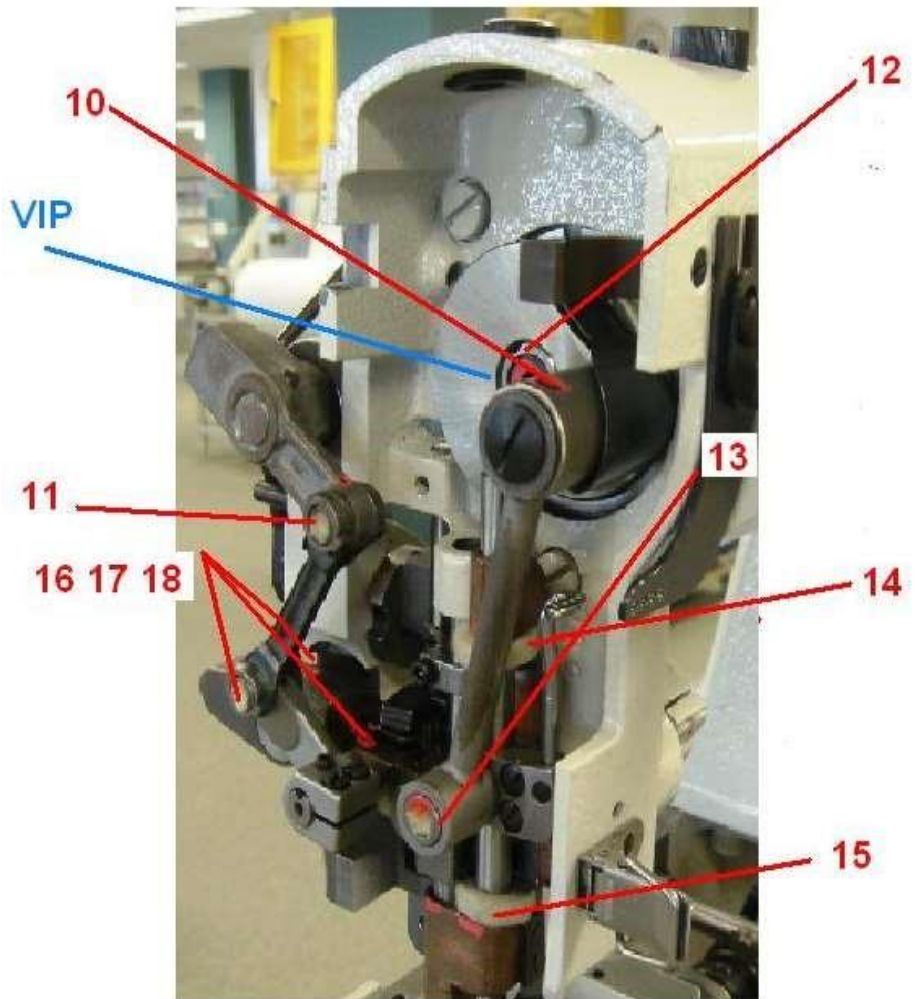
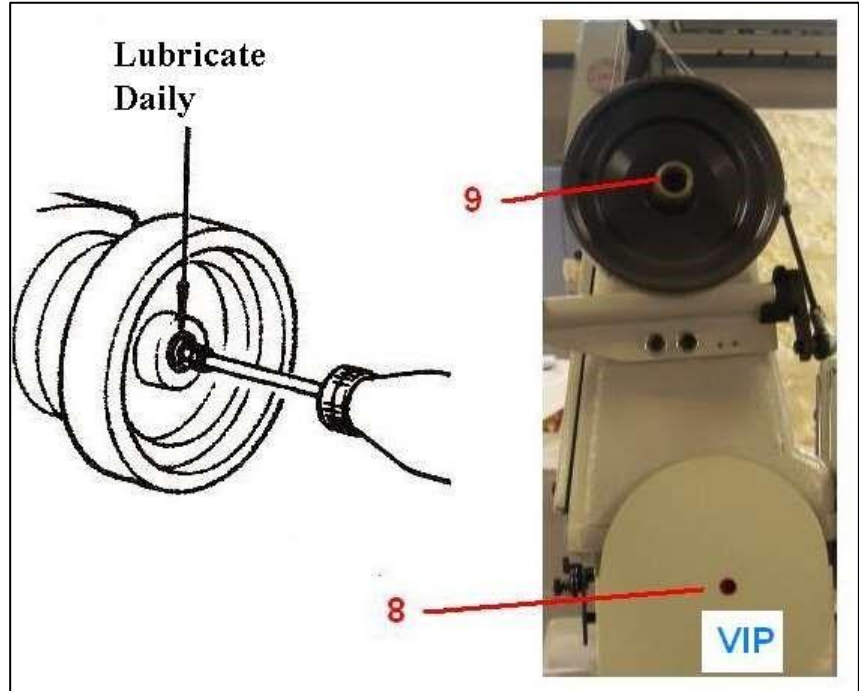

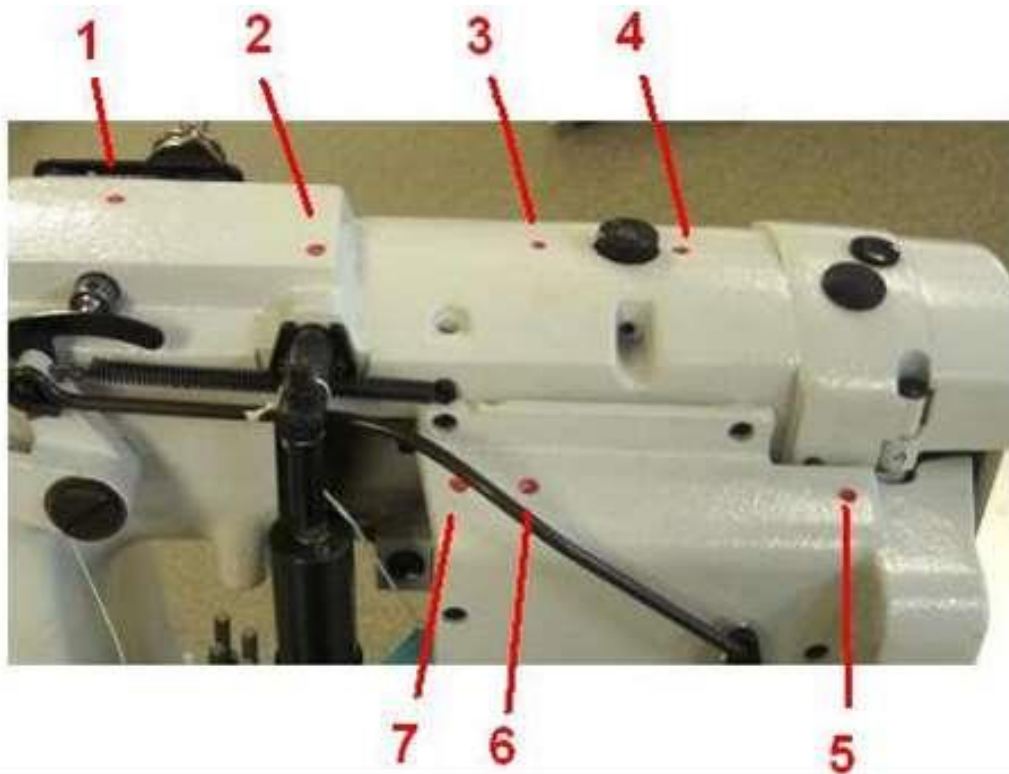
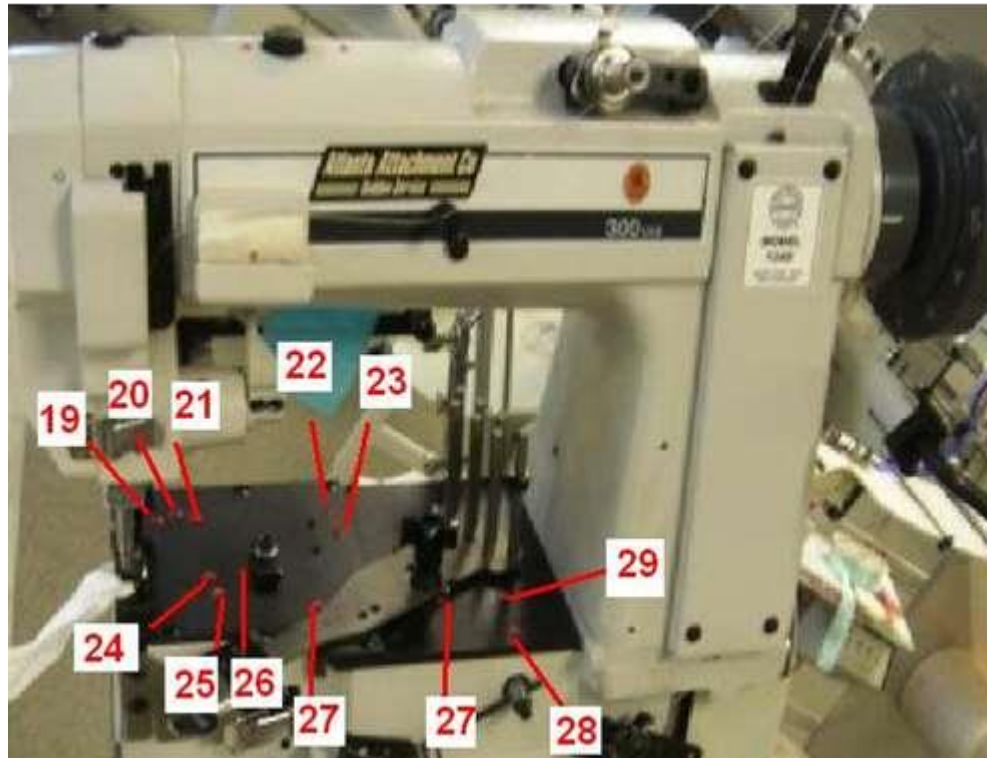

### 3. SERVICE

**NOTE:** Maintenance should only be performed by trained and qualified personnel.

**Practice all safety precautions, including, but not limited to Lockout / Tagout Program.**

### 3.1. Lockout / Tag out Program

"Lockout/Tag out (LOTO)" refers to specific practices and procedures to safeguard employees from the unexpected energization or startup of machinery and equipment, or the release of hazardous energy during service or maintenance activities. This requires that a designated individual turns off and disconnects the machinery or equipment from its energy source(s) before performing service or maintenance and that the authorized employee(s) either lock or tag the energy-isolating device(s) to prevent the release of hazardous energy and take steps to verify that the energy has been isolated effectively. The following references provide information about the LOTO process.

Equipment Energy Control Procedure Lockout/Tag out Program				
Description:		<b>Tape Edge</b>	Model:	<b>1345-2C</b>
Manufacturer:		<b>Atlanta Attachment Co.</b>	Location	
Energy		Location	Magnitude	Control Method
Electrical	X	Control Box	220V	Lockout & Tag
Pneumatic	X	N/D	N/A	
Gravity:	X	Belts		
<b>Remember to Release All Stored Energy!</b>				
<b>Shutdown Procedure:</b>				
<ol style="list-style-type: none"> <li>1. Inform all affected personnel that the machine will be in Lockout status.</li> <li>2. Turn the power and pneumatic disconnects to the OFF position.</li> <li>3. Fill out the tag with necessary information of the Lockout.</li> <li>4. Install the Lockout device.</li> <li>5. Verify all stored electrical energy has been released by pressing the power on button. . Also, use meter to test circuits in the electrical panel to insure stored energy is released there as well.</li> </ol>				
Perform necessary maintenance, services and/or repairs.				
<b>Startup Procedure:</b>				
<ol style="list-style-type: none"> <li>1. Inform all affected personnel that the Lockout of this machine is being removed.</li> <li>2. Replace any guards or safety devices which may have been removed during maintenance.</li> <li>3. Remove the Lockout device and tag.</li> <li>4. Turn the power and pneumatic disconnects to the ON position.</li> <li>5. Push the green button on the back of the control panel to turn the machine on.</li> <li>6. Inform all affected personnel that the Lockout has been removed and that the machine is ready for normal production operation.</li> </ol>				

Approved by: \_\_\_\_\_

Date: \_\_\_\_\_

## 3.2. Mechanical Adjustments

**NOTE:** All maintenance must be carried out by a qualified service technician.

It is important that the operator read this manual and become familiar with all the safety features and functions of the unit before using it.

### 1. Table Adjustment

#### 1. Movement of the Central Column

The square column of the table has a maximum displacement of 6 inches (15.24 centimeters). With the use they will present wear in the internal guides of Teflon "A" that support it and can cause irregularity in the seam and the operator would need to make constant adjustments of height during the seam.

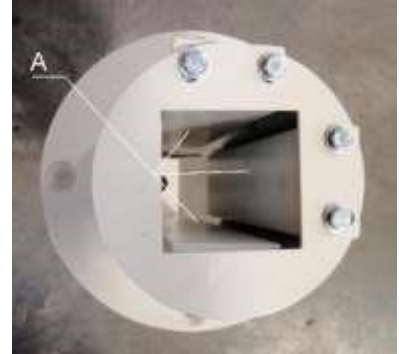

To verify the steadiness of the table, take a corner of it and try to turn it. If you notice excessive play, the following adjustment is necessary.



- a. Lift the table to its maximum position and loosen the four screws "C" of the upper dust cover. Loosen the four lock nuts "B" of the two upper adjustment screws "D".
- b. Loosen the four screws "F" of the covers of the lower dust cover. Loosen the four lock nuts "E" of the lower adjustment screws "G".

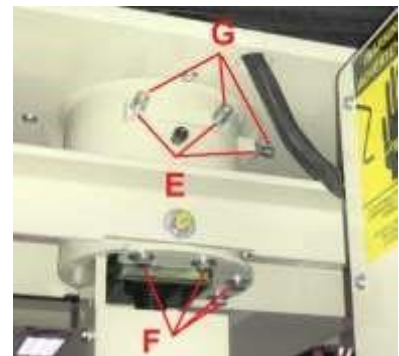

## Service Instructions

- c. Lower the table until the bottom of the table is visible at the bottom of the column guide (a)
- d. Slightly tighten the two upper adjustment screws "D" to move the pads to the inner side. Raise and lower the table with the corresponding switch verifying that it moves freely.
- e. Slightly tighten the lower adjustment knobs "G" to move the pads to the inner side. Go up and lower the table with the corresponding switch verifying that it moves freely.
- f. Tighten the lock nuts "B" and "E" of the adjustment screws "D" and "G".
- g. Replace the dust caps with screws "C" and "F" and check that the table is stable and free to move freely without forcing the motor.

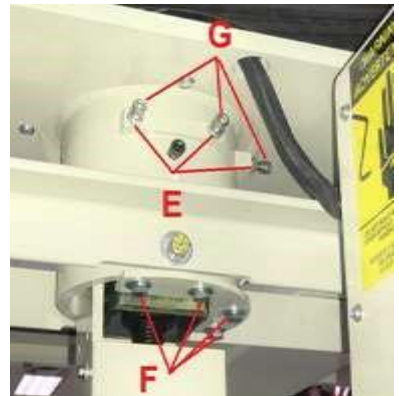

## 2. Alignment and Level

The table must be square and level with respect to the structure of the machine.



- a. Loosen the four screws that support the table to the tower "A" and turn it so that it is square with the structure of the machine.
- b. Check the distance between the four corners of the table and the four corners of the base of the machine are equal. If not, insert shims under them "B" until the best possible alignment is achieved.



## 2. Carriage Adjustment

### 1. Locking Lever

To transport the machine, it is recommended to block the car using the locking knob. In case of sewing mattresses or very light mattresses it is common to block the car and disconnect the clutch using the button 12 of the control panel.

To block, pull the lever out and rotate it 90 degrees.



### 2. Axial Guides.

With the time of use the car can acquire axial play producing irregularity in the seam. To verify take the car and try to rotate it manually as described in the photo. If you feel an excessive play and a slight hit of bearings proceed to make the following adjustment



Before starting the adjustment make sure that the two secondary bearings (a) are in good condition and the support screws are tight.



1. Place the carriage in the straight path of the table and loosen the nut (a) of the main guide bearing (d).
2. Slightly loosen the nut (b) securing the adjusting screw (c). Turn the screw (c) until it contacts the bearing shaft. Slowly tighten the screw (c) until the axial carriage clearance is eliminated. Tighten all the nuts again and check that the carriage moves smoothly across the entire table.

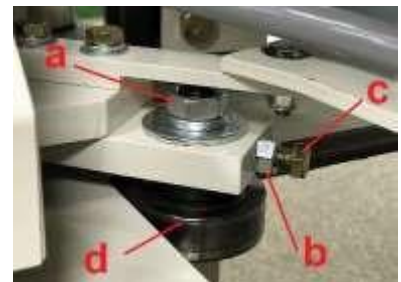

### 3. Corner Shock Absorber,

Its function is to reduce the impact at the end of the turn in the corners.

To adjust, loosen the two nuts (a) and move the shock absorber body outwards or inwards until the car stops hitting at the end of the curve. Tighten the nuts again and check the setting.



## 3. Sewing Head Adjustments

### 1. Pressure of the Presser Foot

**The pressure on the material should be as light as possible but it is still sufficient to ensure correct feeding.**

#### Alternating Pressure

To decrease the pressure, loosen the lower fixing nut and loosen the locking screw, then tighten the upper fixing nut, see fig. 11. When the correct pressure is achieved, tighten the lower fixing nut.

## Service Instructions

To increase the pressure, loosen the upper locking nut and tighten the locking screw, then tighten the lower locking nut. When the correct pressure is achieved, tighten the upper fixing nut.

### 2. Stich Length

To adjust the length of the stitch, press the plunger, fig. 14, located above the arm. Continue holding the plunger down and turning the machine pulley towards the operator until the plunger enters the notch in the eccentric of the arm shaft. Then turn the plunger to lock it in that position. Press the button located on the bed of the machine. Hold and turn the machine pulley towards the operator at the length of the stitch increase, or away from the operator to decrease the length of the stitch.

The letter "A" will have the longest stitch.

Once the correct stitch is obtained, release the button on the bed and return the plunger of the arm to its original position.

**CAUTION: Never return to the machine pulley with the plunger in the locked position until the button on the bed of the machine is decompressed.**

### 3. Synchronization of the Upper Shaft and the Lower Shaft.

**Rule:** When the needle bar is at its top dead center (between the letters K and L on the flywheel) the mark on the lower gear pulley must be pointing upwards

#### Adjustment:

Turn the wheel to place the needle bar in the top dead center. In this position check that the arrow on the pulley of the lower shaft is perfectly vertical, with the pointed tip pointing upwards.

If it needs to be adjusted, remove the toothed belt from the lower toothed pulley and take it back to the required point.

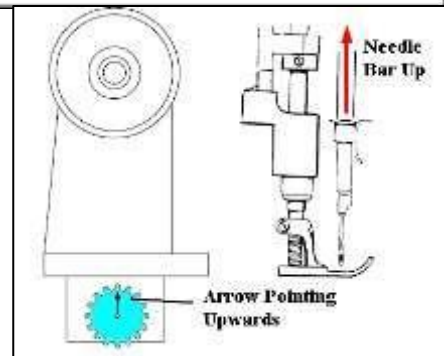
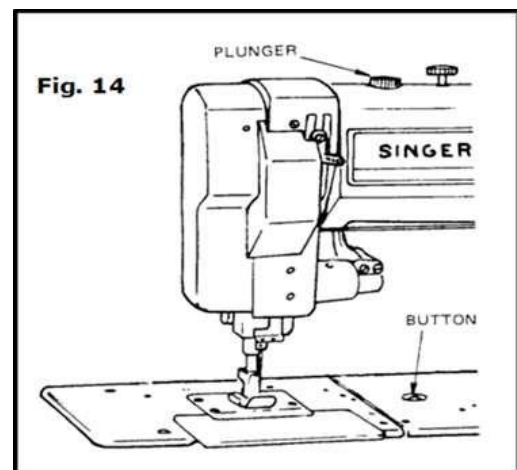
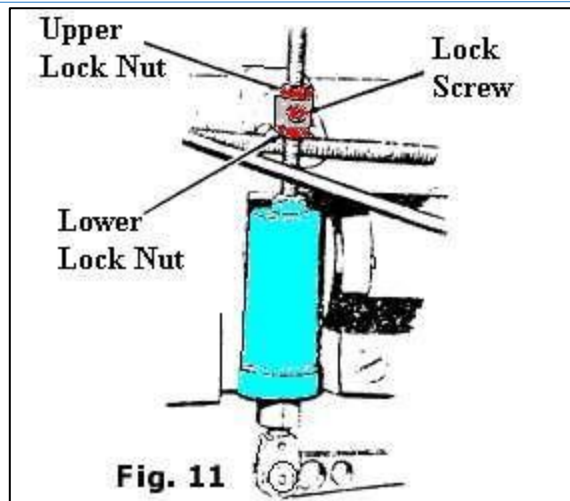

## Service Instructions

### 4. Alternating Presser Adjustment

**Rule:** The height and elevation of the pressers is controlled by an adjustable eccentric. For coarse material a greater movement is necessary, for light materials a minor movement is recommended. Limiting the elevation of the presser foot to a minimum required for the job allows higher speeds.

**Adjustment:** To adjust, remove the arm cover on the back of the machine. Turn the machine pulley towards the operator until the feed press is down. Insert a screwdriver into the notch of the adjusting eccentric and turn the machine pulley as shown in fig. 17.

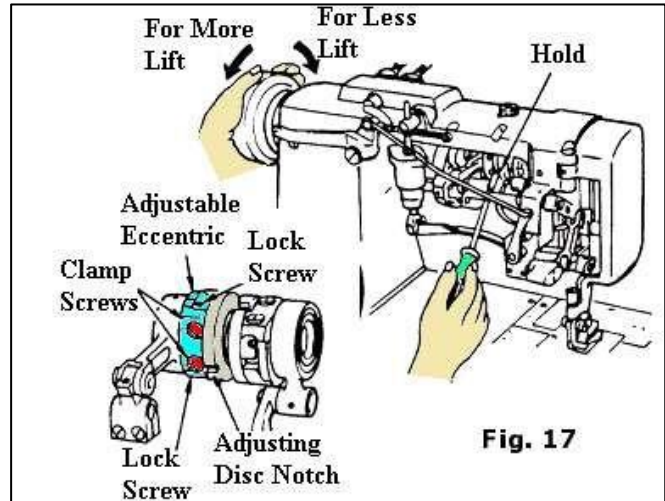

### 5. Balance the Movement of the Presser Foot and the Accompanying Foot.

**Rule:** The presser foot and the accompanying foot should rise to the same height.

**Adjustment:** Turn the machine pulley in the direction of rotation until the lifting foot is in its highest position. Loosen the tightening bolts of the tug, fig. 18, and turn the crank lift shaft up or down until the desired lift of each presser foot is achieved. Tighten the two screws.

### 6. Timing of Accompanying Foot

**Rule:** The vibrating presser should be timed so that under normal sewing conditions, the presser foot will seat on the material at approximately the same time the needle enters the material. This timing can be advanced or retarded slightly depending on the type of operation being performed, such as sewing over seams.

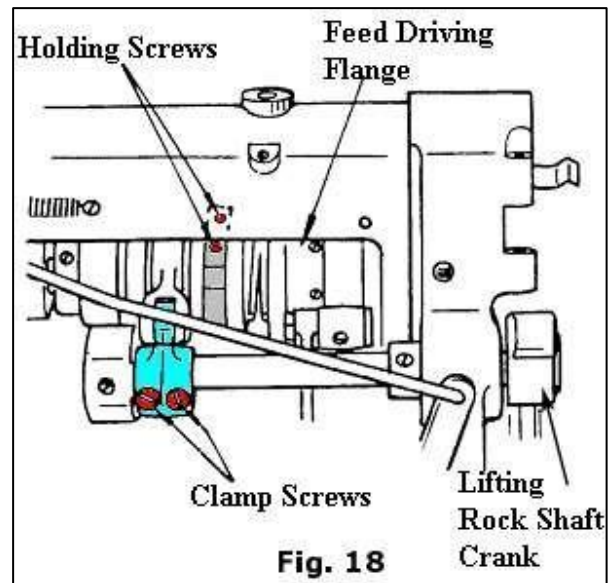

**Adjustment:** To adjust, loosen the two holding screws, Fig. 18, not more than one half turn. Then turn the adjustable eccentric, Fig. 17, until the vibrating presser seats at the correct time. Securely tighten the two holding screws after the adjustment is made.

### 7. Adjustment of the Feed Dog

#### Centralizing the Feed Dog

#### Sidewise Setting

**Rule:** The feeding tooth must have the same opening distance with respect to the needle plate at both ends of the feed path.

## Service Instructions

**Adjustment:** To adjust, set the feed to the desired length of the stitch. Loosen the two screws for tightening the drive shaft, fig. 20. Move feeder shaft forward or backward until correct positioning is achieved. Tighten the two clamp screws.

### Setting the Height of the Feed Dog

**Rule:** When the height of the lower tooth is set correctly,  $\frac{3}{4}$  will be raised to a full tooth above the level of the needle plate.

**Adjustment:** To adjust, loosen the lock nuts, Fig. 21, and slightly loosen the feed dog clamping screw. To raise the feed dog, turn the jack screw clockwise; to lower, turn the jack screw counterclockwise and tap the feed dog down. When the correct setting is attained, tighten the clamping screws and lock the nuts.

### Timing the Feed Lift Eccentric

**Rule:** When the feed dog is at its highest position, the top of the teeth should be parallel with, and project full depth of the teeth above the upper surface of the throat plate.

**Adjustment:** To adjust, insert screwdriver in the hole in the feed strap and loosen the two set screws, Fig. 22. Move the feed lift eccentric forward for earlier rise of the feed dog, or backwards for later rise. Then tighten the two set screws.

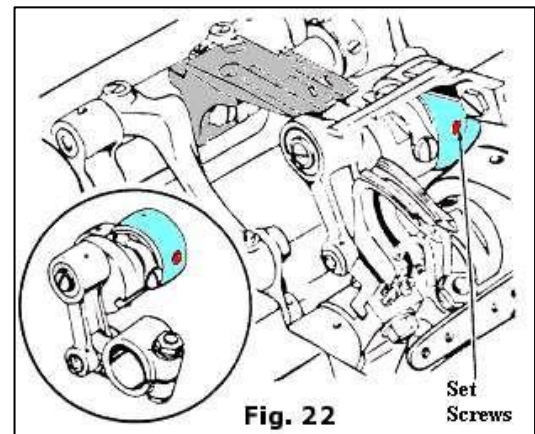
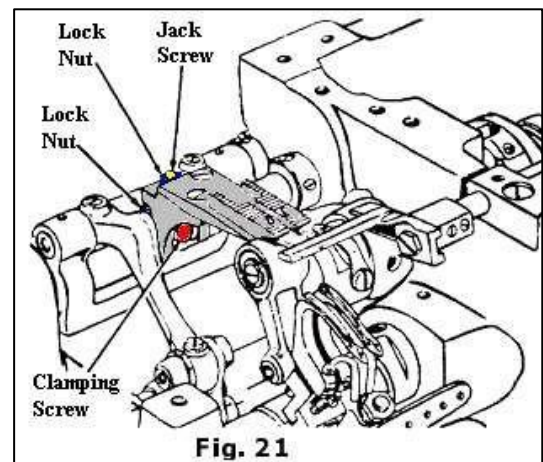
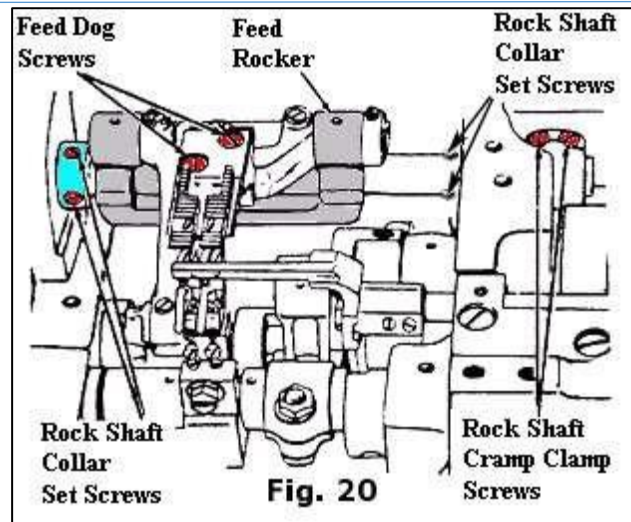

## 8. Needle Bar Adjustment

### Needle Bar Positioning

**Rule:** The needle should enter the needle hole of the feed dog with equal distance to the front as towards the lateral sides of the feed dog ( $a = b = c$ ).

**Adjustment:** To adjust, press the needle bar rock frame, Fig. 23, against the drive arm clamp screws. Continue holding the rock frame against the drive arm, move the needle bar to correct the position and tighten the two clamp screws.

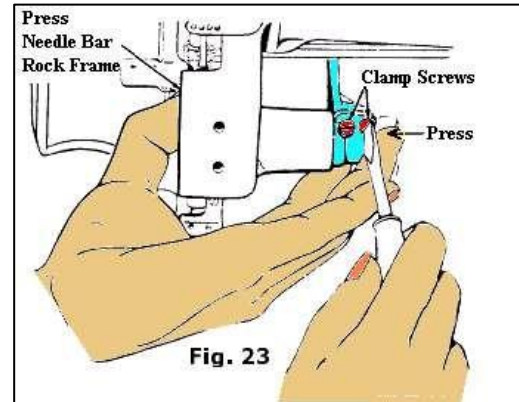
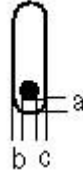

## 9. Adjusting the Loop Deflectors

### Positioning the Loop Deflectors

**Rule:** When the loop deflector, located on the underside of the feed dog, is positioned correctly, there should be a clearance of approximately  $1/32''$  between the right side of the needle and loop deflector.

**Adjustment:** To adjust, move the looper out of sewing position and tilt the machine back on its hinges. Loosen the loop deflector screws, Fig. 24. Move the deflectors toward the rear of the feed dog as far as the screw slots allow. Tighten slightly to allow for further adjustment. Return the looper to the sewing position and turn the machine pulley until the needle bar has descended to the bottom of the needle bar stroke. Tap the deflector to the left or right until the correct clearance is attained. Move the looper out of the sewing position and tighten the loop deflector screws.

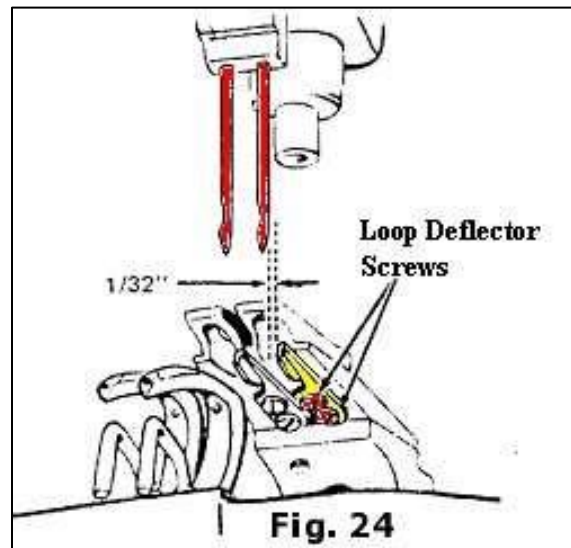

## 10. Adjusting the Loopers

### Setting the Distance from the Looper to the Needle

**Rule:** When the needle is at its bottom dead center and the looper at its rear dead center the distance between the looper tip and the center of the needle (2) should be around 4.8 mm or  $3/16$  inch.

**Adjustment:** Turn the steering wheel in the direction of the seam and align the letter "F" on the steering wheel with the ">" symbol on the helmet of the machine.

Keeping this position, loosen the clamping nut holder support of the looper carrier fig. 27. Move the looper forward or backward until the looper point is about 4 millimeters or 3/16 "(4.8mm). Tighten the clamping nut.



### Looper Inclination

**Rule:** The looper must be set so that it must have an inclination of 90 to 91 degrees with respect to its base. Your tip should be .00 to .05 millimeter separated from the needle while passing through its recess.

**Adjustment:** To adjust, loosen the two adjusting screws of the looper. Turn the looper to the left or right until the correct angle is achieved. Hold in position and tighten the two set screws securely.

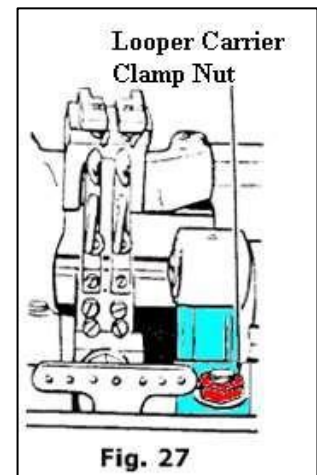

### Sidewise Setting

**Rule:** When correctly set: the point of the looper should be directly opposite of the center of the needle, and at the center of the clearance above the eye of the needle when the looper timing mark LT on the machine pulley is opposite of the timing arrow on the arm.

**Adjustment:** To adjust, turn the machine pulley until the point of the looper is in the center of the needle. Loosen the screw of the locker holder fig. 25, and move the holder slightly to the left or right until the correct separation is achieved. Securely tighten the looper bracket screw.

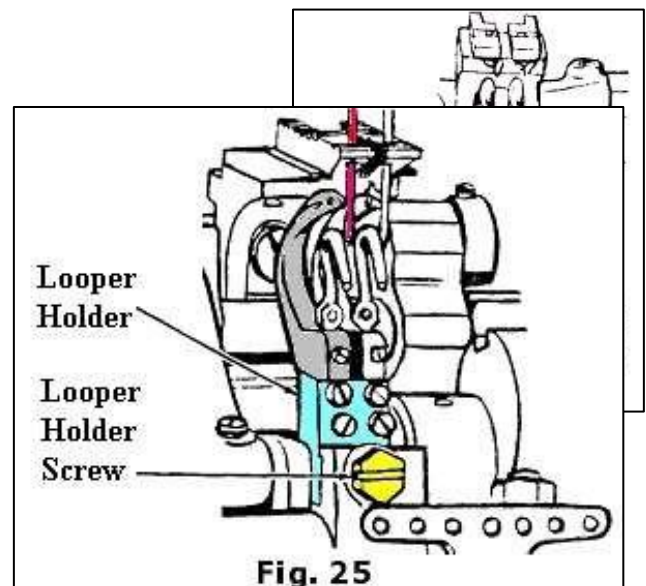

### Timing Looper Driving Crank

**Rule:** When positioning the machine's steering wheel in the DLT position and returning it to position G, the looper tip will pass through the needle at the same height in the two front and rear positions of the looper.

**Adjustment:** When the tip of the looper passes higher in the forward movement, loosen the clamping screw of the looper eccentric fig. 29. Loosen the loop screw of the looper (left) approximately 1/8 "(3.2mm) turn and tighten the timing screw of the looper crank (right). Continue adjusting until the correct adjustment is made.

Securely tighten the pressure screw.

When the looper tip passes higher in the recoil movement, reverse the adjustment by loosening the time screw (right) and tightening the time screw (left).

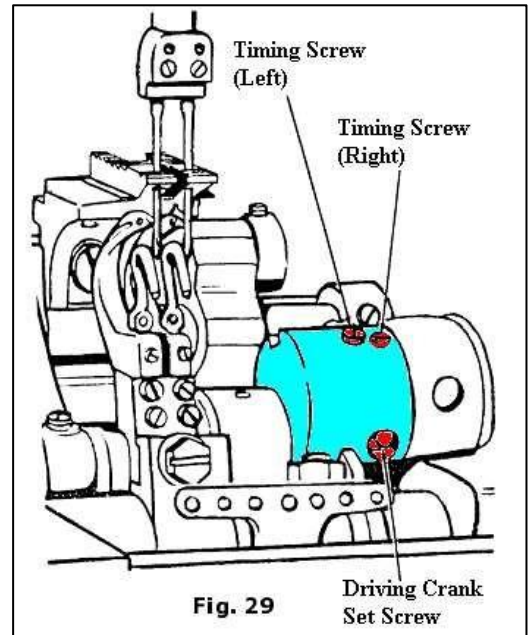

### Longitudinal Fine Adjustment and Adjustment of the Height of the Needle Bar

**Rule:** When properly fixed, when rotating the machine in the direction of rotation and aligning the DLT mark on the Handwheel with the chassis mark of the machine, the point of the locker must be at the front end of the needle, 2 millimeters high with regarding the upper part of the eye of the needle.

**Adjustment:** To adjust the looper, loosen the clamping nut of the looper bracket fig. 27. Move the support forward or backward until the point of the looper is aligned with the front end of the needle. Tighten the clamping nut.

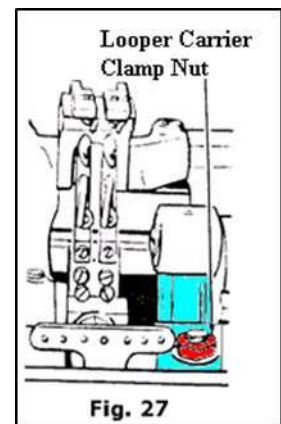

## Service Instructions

To adjust the needle bar, first make sure that the needle is inserted as high up on the bar or the needle clamp as deep as possible. Loosen the two fixing screws of the needle bar, fig. 28, and raise or lower the needle bar to correct the position. Tighten the fixing screws. Fig. 27 fig. 28

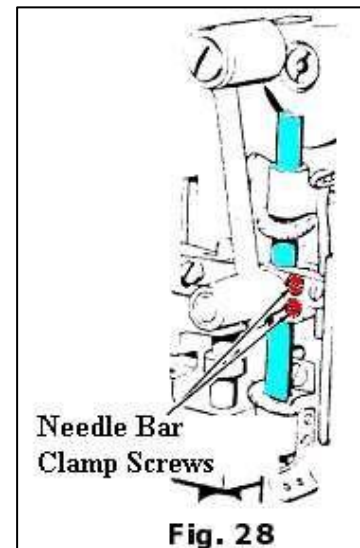

**Adjustment:** To adjust the needle bar, first make sure that the needle is inserted as high up on the bar or the needle clamp as deep as possible. Loosen the two fixing screws of the needle bar, fig. 28, and raise or lower the needle bar to correct the position. Tighten the fixing screws. Fig. 27 fig. 28

## Setting the Needle Guards

**Rule:** When the needle guards are properly set, they should pass as close as possible to the needles without touching and the thread should never be pressed by them.

**Adjustment:** When the needle guards are properly set, they should pass as close as possible to the needles without touching. To adjust the guard, turn the machine pulley over toward the operator until the points of the Loopers are about to pass the needles on their forward strokes. At this point, the looper timing mark DLT on the machine pulley should be approximately 1/8" above the arrow on the machine arm.

Loosen the needle guard set screws, Fig. 30. Turn the needle guards as close to the needles as possible without touching. Tighten the set screws. Check by springing the needles to the left and turning the machine pulley to make certain that the looper points do not stroke the needles.

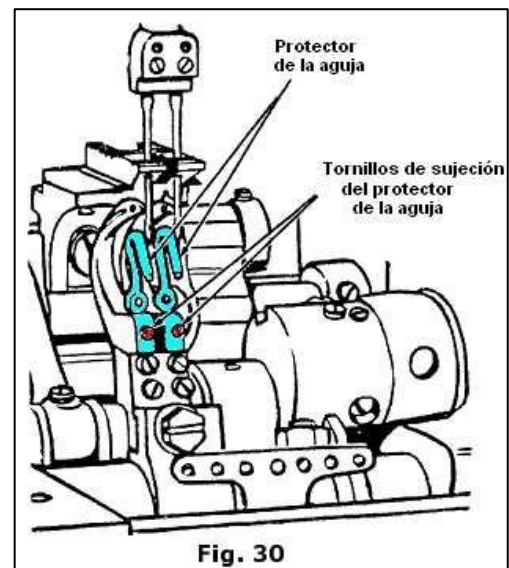

## 11. Thread Controls

### Positioning Spreader

#### Sidewise and Height Setting

**Rule:** When the looper on its forward stroke is passing the spreader

- The point of the spreader should be exactly opposite the top of the thread groove at the left side of the looper.
- The clearance between the spreader point and the looper should be approximately the double thickness of ordinary paper.

**Adjustment:** To adjust, loosen the two-spreader holder set screw, Fig. 31. Move the spreader and holder to the correct position. Hold in position and tighten the set screws.

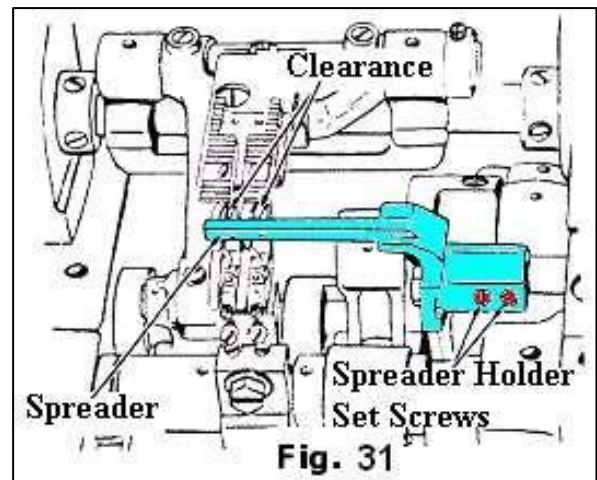

## Longitudinal Adjustment

**Rule:** When the tip of the needle in its downward movement is level with the tip of the spreader, the separation between the two points should be approximately 1/16". (1.6mm).

**Adjustment:** To adjust, loosen the spreader screw, fig. 32, and move the spreader forward or back to the correct position. Then tighten the spreader screw.

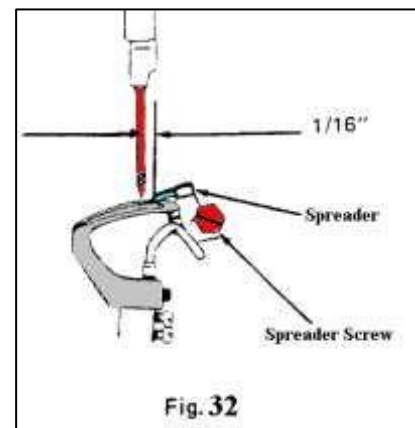

## Changing Movement of Spreader

**Rule:** The sidewise movement of the spreader may be adjusted for sewing under abnormal conditions. Under normal conditions, maximum spreader movement is generally used.

**Adjustment:** To adjust, tilt the machine back on its hinges, loosen the two-spreader driving eccentric screws, Fig. 33, and the two-spreader driving eccentric flange screws. Move eccentric to the left to increase movement, or to the right to decrease movement.

When correctly positioned, tighten the two-spreader driving eccentric screws first, hold flange against strap and tighten flange screws. Then refer to preceding information regarding positioning of spreader.

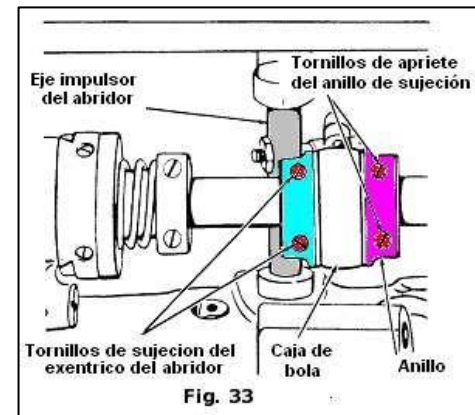

## Adjusting Needle Thread Take-Up

**Rule:** The needle thread take-up and thread guide may be adjusted to increase or decrease the amount of thread drawn at the top of the needle bar stroke

**Adjustment:** To increase the amount, loosen the thread take-up screw, Fig. 34, and raise the take-up or loosen the guide screw and lower the guide. To decrease the amount, reverse the adjustment by lowering the take-up or raising the guide.

For average sewing conditions, the guide should be set with upper end 5/8" above the guide screw. The thread take-up should be set with the lower end 1.378" below the bottom of its holder.

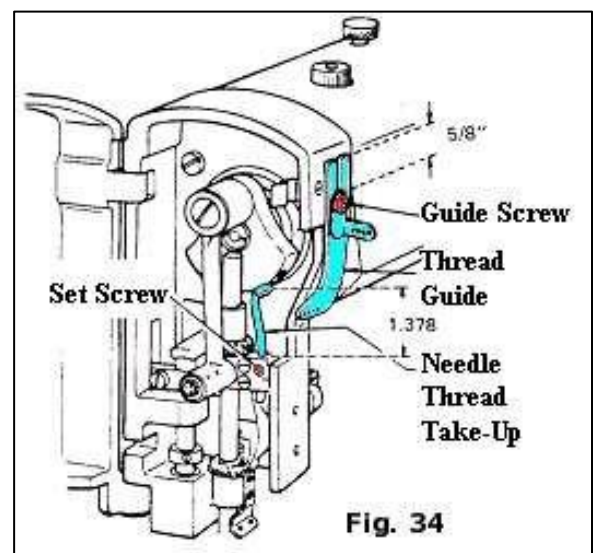

## Service Instructions

### Adjusting the needle thread tension spreader

**Rule:** When correctly adjusted, the tension releaser should release tension on the needle thread when the presser foot is raised and allows full adjusted tension when presser foot is down.

**Adjustment:** To adjust, loosen the set screw, Fig. 35, and move tension releaser cap out for earlier release of tension or in for later release. Hold in position and tighten the set screw. Should the tension releaser not release tension at the correct time after making the above adjustments, loosen the tension sidewise to correct position. Then tighten the screw releaser plate screw and move plate.

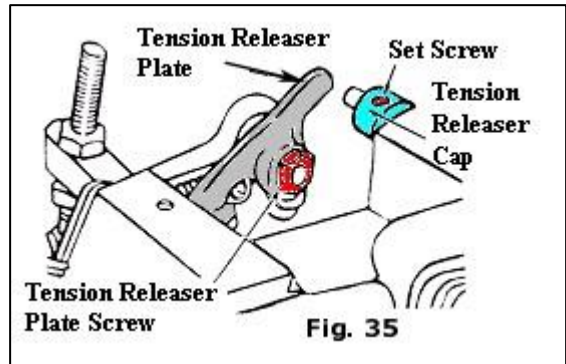

### Adjusting Looper Thread Take-Up

**Rule:** The looper thread take-up and guide may be adjusted for handling a more or lesser amount of thread, according to the thickness of material and length of stitch, and to change the ratio of looper thread in finished stitch.

**Adjustment:** To change the amount of thread handled, loosen the looper thread guide screw, Fig. 36, and looper thread take-up rod screw. Move the thread guide and take-up rod to the left for more thread or to the right for less thread. Tighten the two screws making certain that the take-up rod passes through the center of the guide yoke. To change the ratio of looper thread in finished stitch, loosen the thread guide screw, Fig. 36, and lower the yoke or right end of the thread guide for more thread. For less thread, raise the end of the guide. Hold in position and tighten the guide screw.

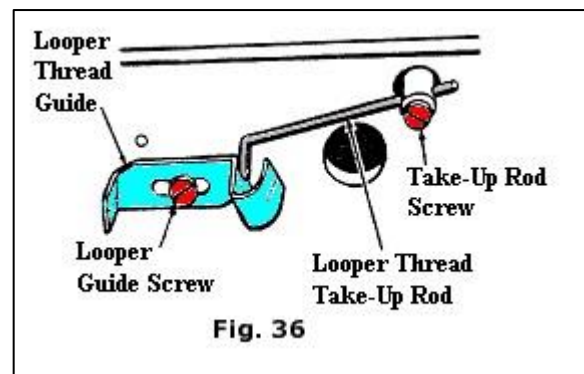

#### 4. Tape Edge Folders

There is a wide variety of fabric folders. It is recommended that the folders match the width of the tape. The folder has a stamped marking that corresponds to the measurement of the tape and the opening of the mouth.



Example: 1-7 / 16 - 3/8 AAC The tape must be 1 7/16 inch wide. The opening of the mouth of the folder is 3/8.

When the measures of the folder and of the tape correspond the finished of border should be even as shown in the figure.

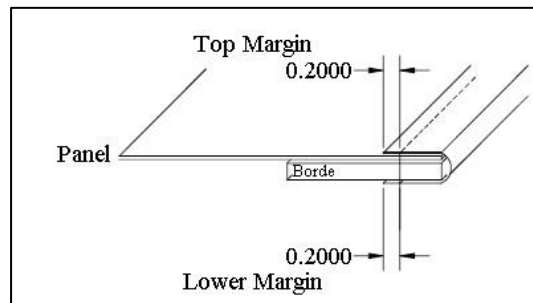

There is a wide variety of fabric folders. These two graphics show examples of folders with special measurements where the amount of tape is extended up or down depending on the client's needs.

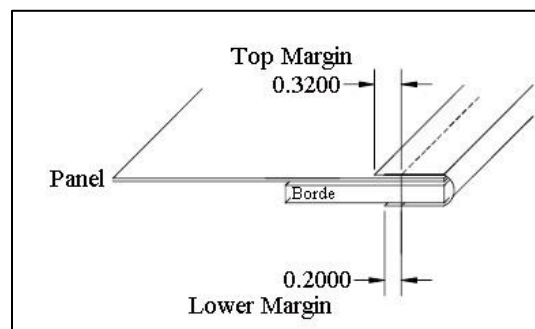
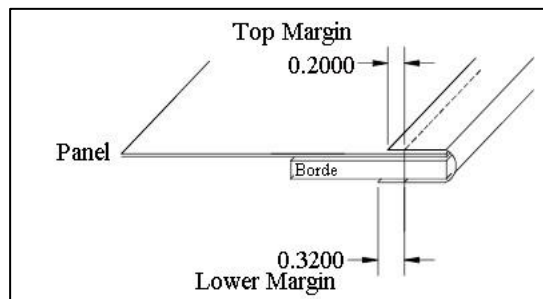

### 3.3. Electrical Adjustments

**NOTE:** All maintenance must be performed by a qualified service technician.

## Service Instructions

### 1. Ground

This unit needs to be grounded for several reasons. In equipment powered by the network, exposed metal parts are connected to ground to prevent user contact with dangerous voltage when electrical insulation fails. In power distribution systems, a protective earth conductor is an essential part of the Earthing safety system. The ground connection also limits the accumulation of static electricity.



### 2. Master Switch.

There is the electrical box on the bottom of the table. It must remain on all the time on its front part has a mechanism that serves as a lock to disable the machine if required.



### 3. Table Motor Contactor

It is located inside the electrical box located under the table. Its function is to protect the motor of the table.



### 4. Electric Transmission Ring

Located at the bottom of the table. It transmits the energy from the electrical input box to the main electrical box.

It has 8 contact tracks as well as 8 brushes.

#### a. Lubrication

All bearings are lubricated for life in the Factory.

#### b. Inspections

Perform the first inspection shortly after installation and before operation. Perform continuous inspections regularly after every 200-400 hours of operation under normal conditions.

## Service Instructions

### 1. Brush Holder

Inspect the brush holders for proper alignment. Locate the brush holders so that the entire contact surface of the brush rests squarely on the ring with the carbon moving freely in the brush holder. Place the brushes slides so that the brush contacts the driver's medium and is not displaced.

Check the tightness of the brush holder clamps. Attach the retaining bolts to 10 in-lb. Max.

Inspeccione las terminaciones de la escobilla en el soporte para asegurarse de que no se imponga ninguna fuerza externa sobre el soporte. Recomendamos cables flexibles o blandos para estas terminaciones. Use abrazaderas externas para soportar todo el peso de los cables.

### 2. Brushes

Inspection for wear. If the distance between the top of the insulator and the bottom of the brush spring is 0.093 "or less, replace the brush blade.

Inspect the contact surface of the brush by removing it. Remove surface dirt, oxidation, pitting or other contaminants (with a wire brush).

To remove and replace the brush:

- 1) Remove the holder screw from the brush holder.
- 2) Remove the brush cable screw.
- 3) Remove the brush holder.
- 4) Replace the brush.
- 5) Re-assemble.

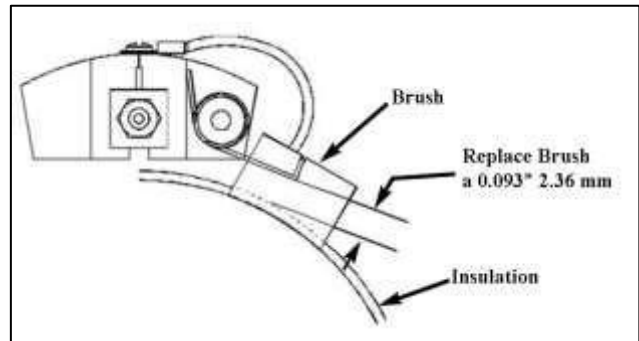

**NOTE: Do not apply any lubricant or solvent cleaning agent to any part of the collector ring.**

### Adjustment of the Brush

The brushes should run at 90 degrees +/- 3% square on the rings. If the brush is not square, adjust the position of the brush holder on the brush post.

It is not necessary that the brushes run in the center of the rings, but there must be no forced friction against the insulators.

The crossbar of the brush spring must be seated in the brush groove.

## Service Instructions

### Brush Springs

Inspect and test the brush springs to ensure even pressure on the brush. If the brush springs fall below the recommended pressure, replace the entire brush holder.

### Rings

Inspect the surface of the ring for dirt, oxidation, or other contaminants. A ring that works properly will have a film that appears burnished in color with a darker background color where the brushes follow. If the ring requires cleaning, order the slip ring polishing kit.

Piece No. 41286

### Electrical Connections

Inspect all electrical connections for corrosion and tightness. Loose and / or corroded terminations will cause excessive heat concentration.

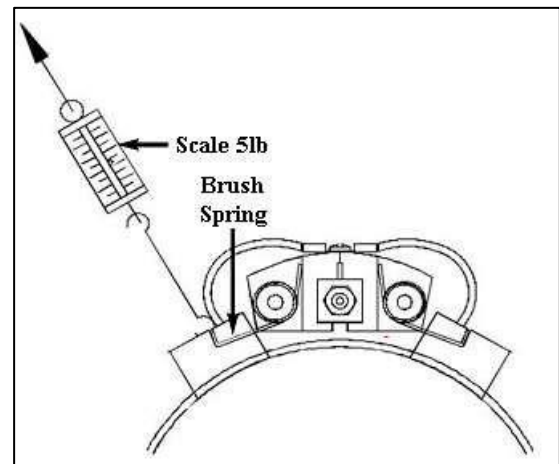
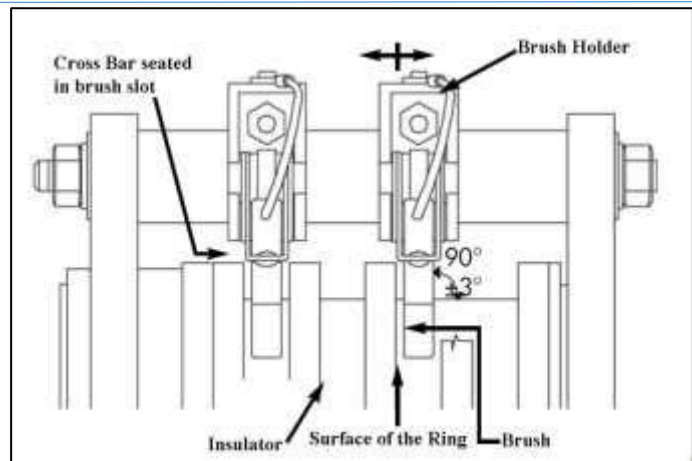

## 5. Main Distribution Box

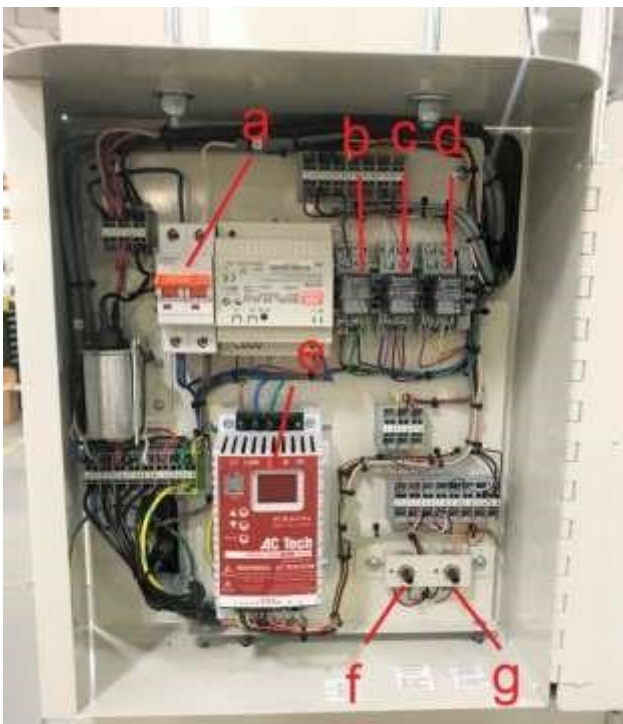

It is in the back of the car. To access the panel an access key is required.

### a. Secondary Switch.

It serves as protection to the distribution box. It should always be on.

### b. Sewing Relay

It is activated during the sewing cycle. Send signals to speed controller to reach sewing speed.

### c. Manual Displacement Relay

It is activated when you press the car release button. Send signal to the speed controller to stop the engine and release the clutch system.

### d. Corner Relay

It is activated when you reach the corners. Send signal to speed controller to reduce sewing speed in corners.

**Note:** The three relays are similar and can be interchanged if necessary.

## e. Variable Speed Drive

Controla las velocidades del motor. Su funcionamiento depende de las señales que le envían los relés b, c y d. There is a list of parameters which is well programmed at the Factory.

## f. Programming of the ACTECH SCL/SCM Unit

The unit is already reprogrammed \*\* with specific configurations for Unit 1345 of Atlanta Attachment Co. These configurations are listed in the table on the next page. Password protection is currently disabled so that the control of the parameters is immediately available to the user. The buttons and the screen on the front of the motor controller can be used to change any specific parameter. Pressing the mode button will access the last parameter displayed. The parameters are designated with a "P" as the first character on the screen. The up arrow and down arrow buttons will move to the desired parameter. Pressing "Mode" displays the current configuration of the parameter (the "up" point of the decimal point flashes). This configuration can be changed using the up arrow and down arrow buttons. When the desired configuration is found, press the mode button to store the new value. This will store the new value and exit the program mode. To change another parameter value, press the "Mode" key again and repeat the procedure.

In the case that the controller has not been preprogrammed by AAC, the factory default password is 225.

Each unit of the SCL / SCM Series has an Electronic Programming Module (EPM) installed on the main control board. The EPM stores the user's parameter settings and the OEM's special default configuration (if programmed). The EPM is removable, which allows its installation in another unit for a quick configuration. For example, if a unit is being replaced with a new one, the EPM can be removed from the first unit and installed in the new unit. Downtime is minimized because the new disk does not require programming; It is ready to work when the EPM is installed.

**NOTE:** The unit will not work without EPM installed. The unit will show "F1" if the EPM is missing or damaged.

### **WARNING!**

Do not remove the EPM while applying power to the unit. Damage to the EPM and / or unit may result. Parameter menu of the sewing motor

### SET PARAMETERS:

P01=02     P19=0.8  
P02=04     P20=0.8  
P04=03     P29=02.5  
P05=02     P46=74.0  
P10=02  
P11=04

ALL OTHERS  
AT DEFAULTS

#### **g. Speed Potentiometer**

Controls the speed in the seam corners. It must be adjusted so that the carriage does not hit the corners and it is possible to control the seam on the part of the operator.

There is a list of parameters which must be programmed each time it is replaced. For a list of parameters, contact Atlanta Attachment.

#### **h. Speed Potentiometer**

Controls the speed of the car in the straight parts of the table travel.

### **6. Motors**

The 1345-2 unit has 3 motor

#### **a. Sewing and Car**

Located at the bottom of the car. The speed of the motor is controlled by the speed controller in the control box. It has two pulleys. The first transmits the rotation movement to the sewing head and the second to the clutch system.



## Service Instructions

### b. Head Tilt

It is located inside the car's cabinet. It is responsible for the inclination of the head. Its travel is mechanically limited by the head. It has a pair of pins (a.b) easy disconnection, if necessary, maintenance, disassemble. Internally has a clutch that holds the head in its position. In case of losing the head position during sewing we must replace the clutch



### c. Table Lift

It is located at the bottom of the table. It is responsible for the elevation of the table. Its route is 12 Inches.

	IN	CM	Maximum Mattress
Floor to Table Down	26.0	66	18.9
Floor to Table Top	38.2	97	6.7
Floor to Needle Top	48.8	124	
Floor to Needle 45 degrees	44.9	114	
Floor to Needle Down	43.3	110	



Internally it has a clutch that holds the table in position. In case of losing the table the position during sewing we must replace the clutch.

### d. Clutch Replacement

#### 1. Disarmament

- Remove the 4 screws according to illustration:
- Separate components

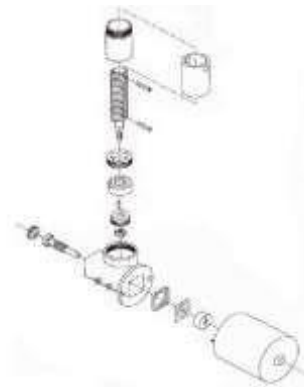

## Service Instructions

- Check that the brake system is free of grease. There must be friction between the fiber discs and the bronze plate. If necessary, replace the brake. Part #: MM14245-002 BRAKE F/MOTION SYSTEM



## 2. Armed

Place the brake in its cavity

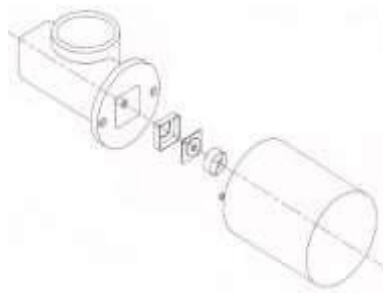

- Place the coupler

- Re-install the motor

## 7. Knee Pad

The operator controls the movement of the carriage using the Knee Pad. The contact plate is adjustable in height after loosening the four screws (a).

If a lower height is necessary, you can move the plate to position “b”

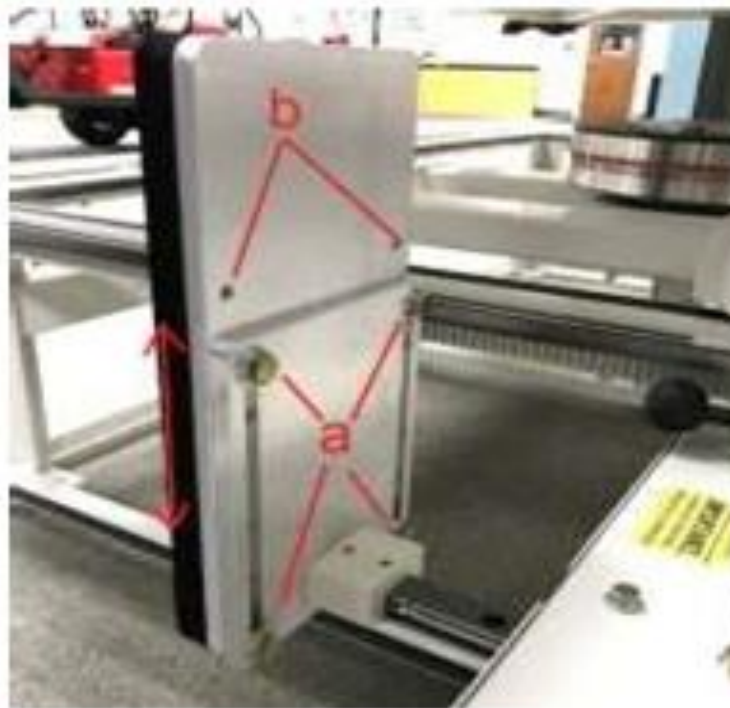

The kneepad connects to the speed controller or actuator.

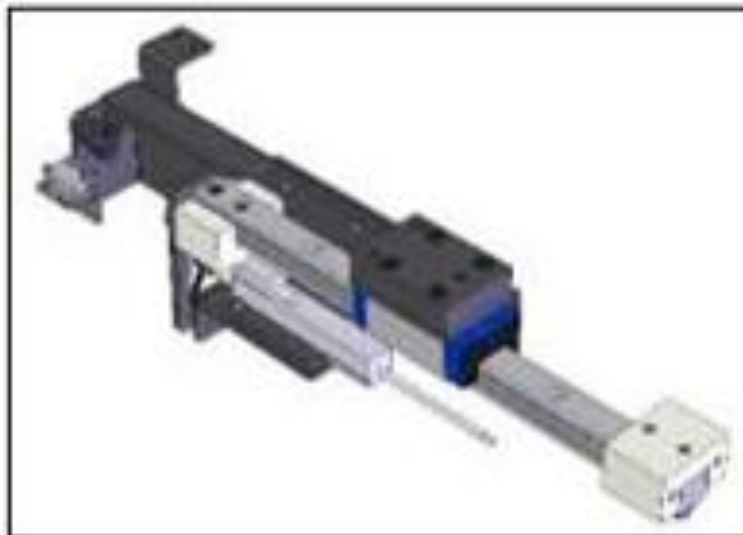

Verification / Testing of actuator switch

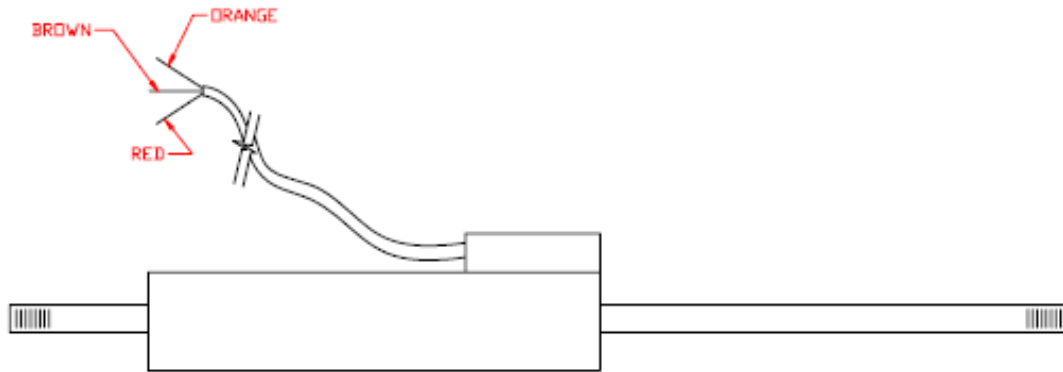

**Rod Extended on the Cable Connector Side**

With meter set on OHMS ( $\Omega$ ) check resistance between the Orange and Red wire and then between the Brown and Red wire.

**ORG - RED = 5 K OHMS (APPROXIMATELY)**

**BRN - RED = 150 - 300 OHMS (APPROXIMATELY)**

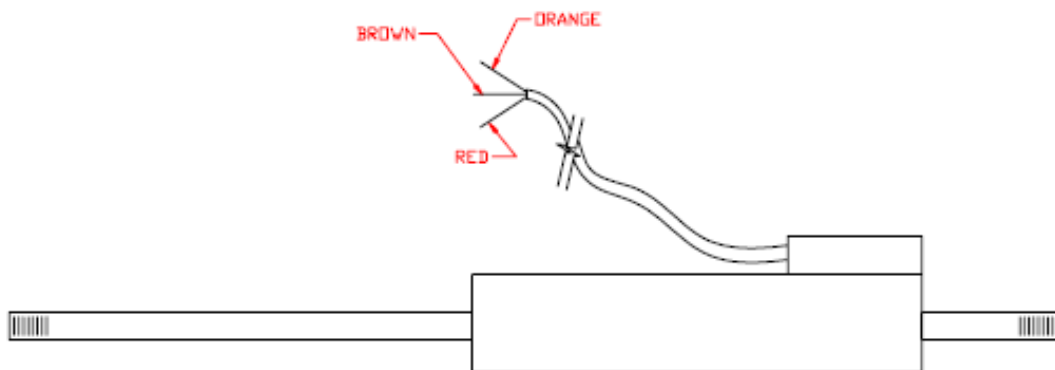

**Rod Retracted on the Cable Connector Side**

With meter set on OHMS ( $\Omega$ ) check resistance between the Orange and Red wire and then between the Brown and Red wire.

**ORG - RED = 150 - 300 OHMS (APPROXIMATELY)**

**BRN - RED = 5 K OHMS (APPROXIMATELY)**

Service Instructions

**8. Electronic Clutch**

Located in the lower part of the cart cabinet. It is an electronic brake free of maintenance. It does not require lubrication, avoid the dropping of oil on it from the sewing head or any liquid inside it.

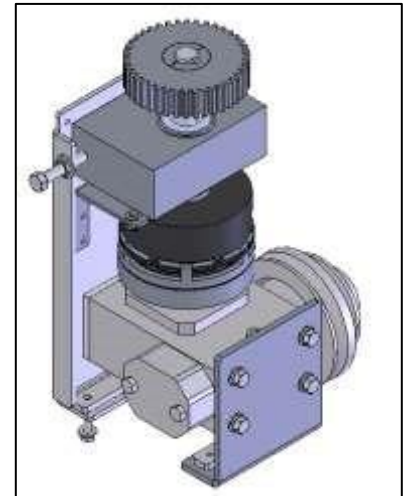

It has three movable plates and six friction surfaces. In case it is necessary to replace the clutches the replacement kit is:

**Part number IMM231631-KIT1**

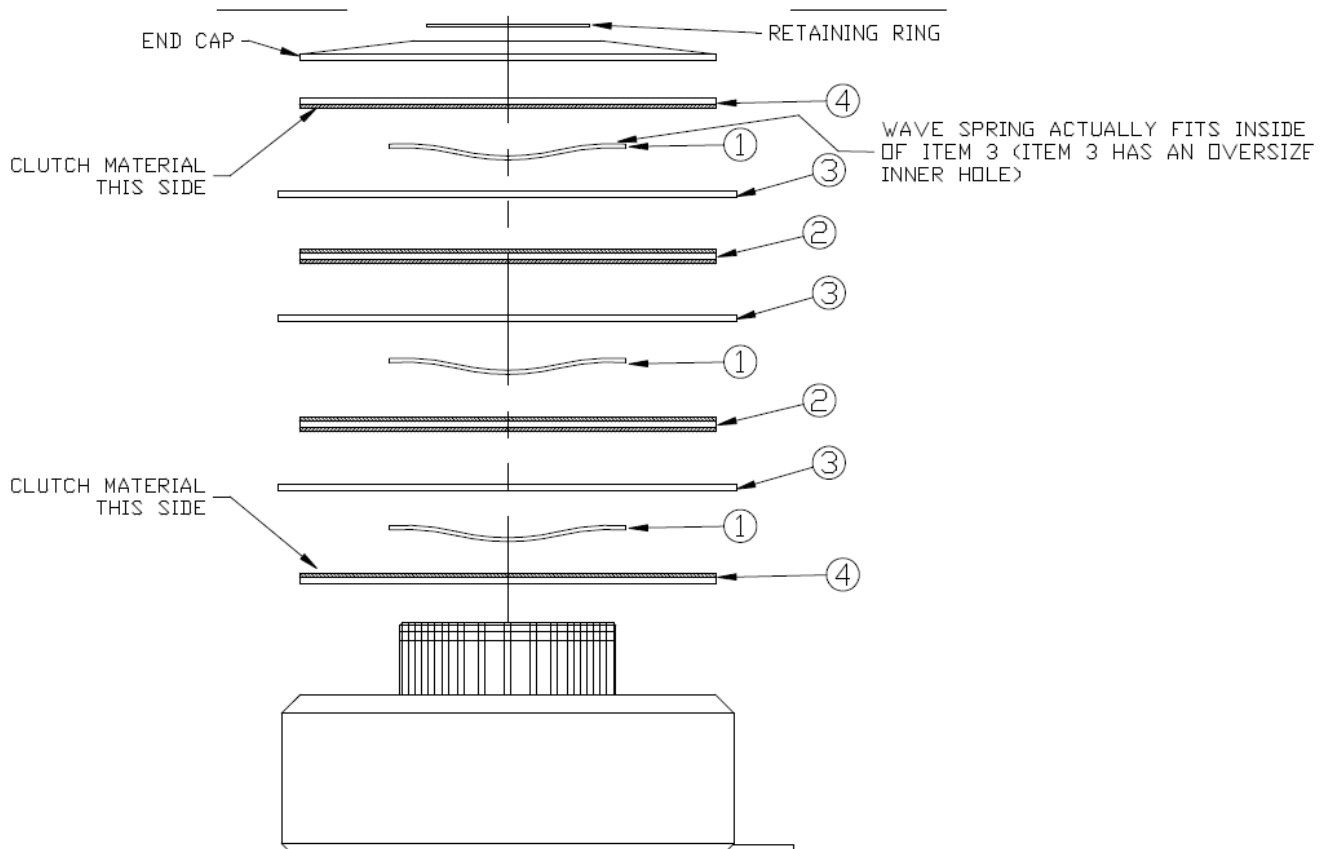

**Individual parts list for clutch**

2	4	SINGLE SIDE CLUTCH DISC	23387900
3	3	OUTER DISC (PLAIN STEEL)	23386400
2	2	DOUBLE SIDE CLUTCH DISC	23388000
3	1	SPRING, WAVE	23055700
QTY. REQD.	ITEM NO.	DESCRIPTION	PART NO. STOCK SIZE

### 3.4. Maintenance

It is important that the operator of the machine read this manual and be familiar with all the functions and safety concerns of the unit before operating.





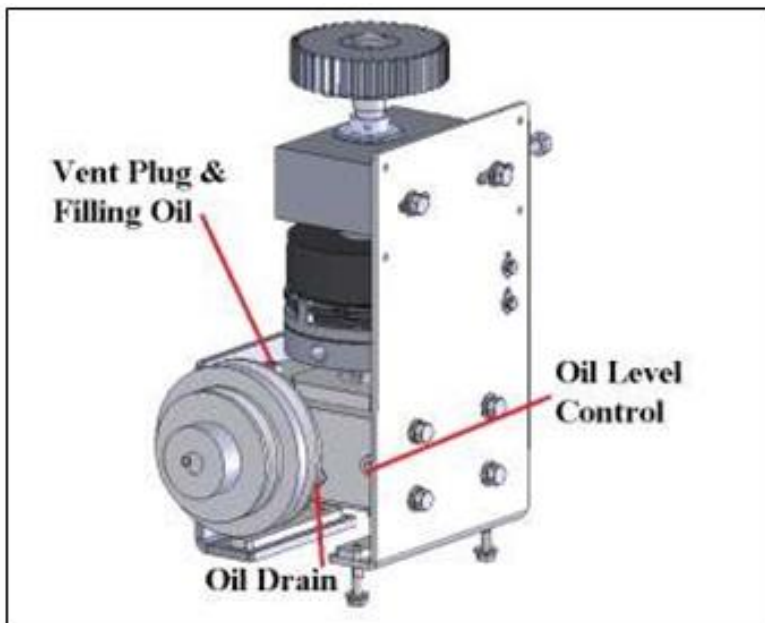

#### Maintenance of the Carriage Drive Reduction Box

- Check the oil level of the gearbox frequently. If the oil level is low, add the proper lubrication until the oil level control goes out.
- Inspect the vent plug frequently to make sure it is clean and functioning.
- Always check the proper oil level. Not filling too much or insufficiently may result in damage
- Use only Mobil Glygoyle 460 polyglycol lubricant. Do not mix the oil.





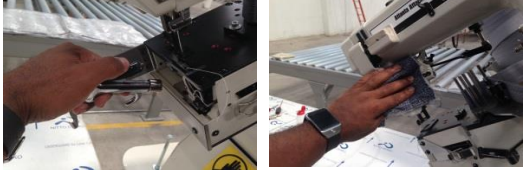

**Preventative Maintenance Schedule    Daily (8 Hours)**

<b>Model:</b>	11345-2 Models	<b>Materials Required</b>
<b>Serial #:</b>		Oilcan with metal tip
<b>Operation:</b>	Tape Edge	Sewing machine Oil
<b>Sew Head:</b>	Singer 300UX6	Lubricant Mobil Glygoyle 460
<b>Serial #:</b>		Clean cloth, Compressed air
<b>Needle:</b>	SN 62x59 180/24	Silicon-based grease

<b>Daily ( 8 Hrs )</b>	<b>Before starting the day's shift with "The Machine Off"</b>	
	.- Open the lids and apply two drops of oil in each of the red lubrication dots and remove excess	
	.- Apply two drops of oil in each of the outer red lubrication dots and remove excess	
	.- Apply a small stream of oil on the top shaft and one on the lower shaft	
	.- Wipe with a clean cloth the table and the machine for any accumulated dirt or excess oil	
	<b>After a day's shift with "The Machine Off"</b>	
	.- Open the top cover and blow out the front area of the needle bar. Remove any tangled thread	
	.- Open the lower front cover and clean the area of the looper. Remove any tangled thread. Wipe with a clean machine.	
	.- Cover the machine and notify the supervisor of any unusual noise or abnormality that is present during the day	

**Preventative Maintenance Schedule      Weekly (40 Hours)**



<b>Model:</b>	11345-2 Models	<b>Materials Required</b>
<b>Serial #:</b>		
<b>Operation:</b>	Tape Edge	
<b>Sew Head:</b>	Singer 300UX6	
<b>Serial #:</b>		
<b>Needle:</b>	SN 62x59 180/24	

<b>Weekly ( 40 Hrs )</b>	<p>.- Unscrew the covers and with an air gun blow out all the accumulated dirt or particles in the hard to reach areas.</p>	
	<p>.- Lubricate the mechanical parts located under the covers</p>	
	<p>.- Lubricate the mechanical parts located at the top rear of the machine</p>	
	<p>.- Lubricate the mechanical parts located at the bottom of the table</p>	
	<p>.- Open the bottom covers and blow the motors area</p>	
	<p><b>.- Perform Daily Maintenance</b></p>	

**Preventative Maintenance Schedule Monthly (160 Hours)**



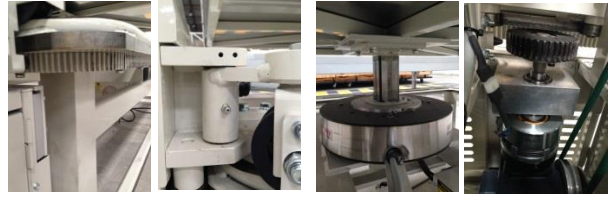

<b>Model:</b>	11345-2 Models	<b>Materials Required</b>
<b>Serial #:</b>		
<b>Operation:</b>	Tape Edge	
<b>Sew Head:</b>	Singer 300UX6	
<b>Serial #:</b>		
<b>Needle:</b>	SN 62x59 180/24	

--	--

<b>Monthly (160 Hrs)</b>	<p>.- Check the tension and condition of the belt on the bottom motor.</p>	
	<p>.- Clean and place two drops of oil on the pivot points between the arm bracket and the electrical cable and on the knee actuator rail</p>	
	<p>.- Clean and lubricate the rail carriage travel guides and bearings</p>	
	<p>.- Place Silicon based grease in the gear of the carriage, grease points of the transport arm and the tower of the central table</p>	
	<p><b>.- Perform Weekly Maintenance</b></p>	

**Preventative Maintenance Schedule Annually (1,920 Hours)**

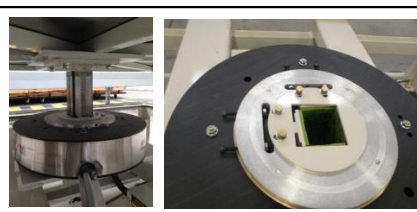
<b>Model:</b>	11345-2 Models	<b>Materials Required</b> Oilcan with metal tip Sewing machine Oil Lubricant Mobil Glygoyle 460 Clean cloth, Compressed air Silicon-based grease
<b>Serial #:</b>		
<b>Operation:</b>	Tape Edge	
<b>Sew Head:</b>	Singer 300UX6	
<b>Serial #:</b>		
<b>Needle:</b>	SN 62x59 180/24	

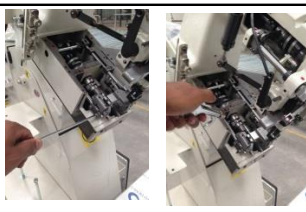
<b>Annually ( 1.920 Hrs )</b>	.- Check if there is any play in the carriage against the table and recalibrate if necessary	
	.- If required recalibrate the damper corners	
	.- If required readjust the column of the worktable	
	.- Check the oil level in the gearbox and add if necessary: Use lubricant Mobil Glygoyle 460 polyglycol	
	.- Tighten all the screws on the lower and upper transport system	
	.- Check any wear and replace parts if necessary	
	.- <b>Perform Monthly Maintenance</b>	

## Service Instructions

---

### 1. General Security Instructions

Maintenance should only be carried out by trained and qualified personnel. Turn off power, pneumatics, etc. before carrying out any maintenance or repair work. of the machine in the main source and secure it with a padlock so that it cannot be turned on again without authorization. See Lockout / Tagout Procedures

- Always use the appropriate safety equipment when operating or performing maintenance on any equipment.
- All recommended maintenance is for a single shift schedule; adjust as necessary for a multishift operation.
- The equipment must not be used for other purposes that are not designed or specified.
- The machine must be switched off, stopped, and secured so that it cannot be switched on again inadvertently before starting any maintenance work.
- Use proper lockout / tag out procedures to ensure the machine prevents inadvertent starting.
- Remove any oil, grease, dirt and waste from the machine, especially the connections and screws, when starting the maintenance and / or repair work □ Do not use corrosive cleaning agents.
- Use lint-free cloths.
- Retighten all screw connections that must be loosened for maintenance and repair work.
- All safety mechanisms that must be disassembled for installation, maintenance or repair must be repaired and verified immediately after completing the work.

### 2. Preparation

- Turn off the machine.
- Open all the covers of the machine and the car.

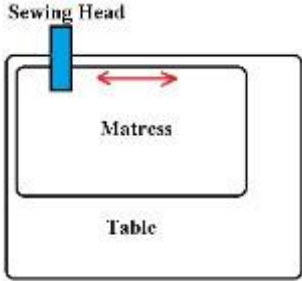

### 3.5. Troubleshooting

Problem	Cause:	Corrective Action
Machine does not turn on	<ul style="list-style-type: none"> <li>□ Electrical fault</li> </ul>	<ul style="list-style-type: none"> <li>• Check that the green light on the electrical box under the table is on</li> <li>• Check that the switch inside the main box is activated</li> </ul>
Stich Jump	<ul style="list-style-type: none"> <li>• Thread Tensions</li> <li>• Trimmer adjustment</li> <li>• Needle position.</li> <li>• Feeding Dog</li> </ul>	<ul style="list-style-type: none"> <li>• Check the threading of the threads and then correct their tension.</li> <li>• Check all settings of the Loopers and the Spreaders. Use the manual as reference.</li> <li>• Check the state of the needle and control its position.</li> <li>• Check that the feeding dog is not worn as shown in the red area in the graf</li> </ul>  <p>The diagram shows a side view of a feeding dog mechanism. It consists of a series of vertical bars on the left and a curved, hook-like shape on the right. A red highlight is applied to the curved portion, indicating the area of wear.</p>
Mattress moves on the table during sewing	Stitch length adjustment in relation to carriage movement	<p>Refer to stitch length in the sewing head manual. If the stitch is too long, the mattress moves in the direction of the sewing head. If the stitch is too short the mattress moves in the direction of the operator.</p>  <p>The diagram illustrates the relationship between the sewing head, the mattress, and the table. A blue vertical bar labeled 'Sewing Head' is positioned at the top edge of a rectangular 'Matress' which sits on a 'Table'. A red double-headed arrow is drawn horizontally across the top of the mattress, indicating the direction of movement.</p>

## Service Instructions

<b>Problem</b>	<b>Cause:</b>	<b>Corrective Action</b>
You have to constantly adjust the table height while sewing	<input type="checkbox"/> Table is not well leveled with reference to its structure	<input type="checkbox"/> Refer to the table setting in the manual
Table loses height during sewing	<input type="checkbox"/> The table motor brake is defective	<input type="checkbox"/> Check the brake plate of the clutch motor. Refer to the manual for motor disassembly
Table loses speed during the sewing run	<input type="checkbox"/> The car slows down on its way	<input type="checkbox"/> Check the carriage settings. This must run free throughout its journey
Machine produces gear noise in the corners	<input type="checkbox"/> The gear that moves the car loses contact with the toothed bar	<input type="checkbox"/> Check the clutch system setting and the distance between the gear and the teeth of the toothed bar

## Service Instructions

### 3.6. High Mortality Kit.

The machine is offered as an option with a set of high mortality parts recommended for the natural consumption of the machine. . The content of the kit is as follows:

Kit de Parts #: **SP13452A1**  
 Station **1345-2 TAPE EDGE WORKSTATION**  
 Head **AAC 300UX5**

Item	Part Number	Description	Qty	Item	Part Number	Description	Qty
1	10148	SPRG,LPR THD TNSN	1	30	559059	FOOT, LFTNG PRSR	1
2	13451021	GEAR RACK,CORNER 10 DP,84 TEETH, 1" THK	1	31	559060	PLATE,THROAT,STD	1
3	13453211A	BELT,HEAD DRIVE, 10MMX108" 1345-2	1	32	559061	FEED DOG,SN 300UX5 SINGER	1
4	13459007	CABLE,POT,5K,5FT 11345	1	33	AAOEM.5BSA	SHOCK ABSORBER	1
5	13459008	CABLE,POT,5K, 6IN	1	34	BB305702C	BEARING,CAM ROLLER 1.575 OD, .5906ID,.626THK	2
6	229	SCREW,LOOP DEFL	1	35	BB305705C	BEARING,CAM ROLLER 2.4409 OD,.9843ID,.881THK	1
7	267665	LOOP DEFLECTOR	1	36	BB6204-2Z	BEARING,BALL,P GROOVE 1.850D,.7874ID,.551THK	1
8	267718	RETAINER,PRESSER BAR SPRING ARM BEARING	1	37	EE3X01	BLOCK,PUSH BUTTON CONTACT N.C. F/3 ACROSS MOUNTING	
9	268032	SPRG,FACE PLT LOCK	1	38	EE3X10	BLOCK,PUSH BUTTON CONTACT N.O. F/2 ACROSS MOUNTING	1
10	268052	ROD,LPT THD TKUP	1	39	EECA491024	CONTACTOR,MINI,240V	1
11	268512	GDE,NDL THD, NDL BAR STD	1	40	EED5N157	LAMP,INC,BAYONET,24V,1.4W	1
12	276025	BALL,PRSR BAR SPRNG ARM	2	41	E EK10P11D1	RELAY,24VDC,DPDT 15A-AC,PLUG-IN	2
13	281208	LOOPER,300UX5	2	42	EERHU02800	HOLDER,BRUSH	1
14	281912	BAR,NDL	1	43	EERHU45066C	BRUSH FOR SLIP RING ASSY EERHU-B08	2
15	281929	LEVER,FOOT LIFTER 300UX05	1	44	FF002304A	LINEAR TRANSDUCER ASSY 1345	2
16	281975	SPREADER,300UX5	2	45	FF2938947	POWER SUP,SWITCHER,24 V 1.5A, 85- 265 VAC,DIN RAIL	1
17	374107-001	SCREW,THRT PLAT BACK	2	46	FFL722C	CIRCUIT BREAKER,THERM-MAG 2 POLE,2A,DIN RAIL	1
18	414518	SCREW, THRT PLT FRNT	2	47	FFUZP111	PROX. SENSOR, SUNX,10-30VDC LEAVE- ON,ROBOTIC CABLE	1
19	414519	SCREW,NDL SET	5	48	IISO16X112	SPRING PIN 1/4 X 1-3/4 STEEL	1
20	414552	SCREW,SPRDR	2	49	MM9540K53	BUMPER,RUBBER 3/8" WITH WASHER	2
21	414638	SCREW,FOOT,OUTER (VIBRATING AND LIFTING)	4	50	MM98335A064	PIN,COTTER TO FIT 3/8-7/16 SHAFT	1
22	415291	STUD,THSN,LPR THD	1	51	MMN5S1040M1	GEAR,DRIVE,40TH,10P,W/KEY 11345	2
23	415292	STUD,CLAMPING 300UX5	1	52	MMVPS-112	BEARING, PILLOW BLOCK, 3/4 BORE	1
24	50326	STUD, NDL THD TNSN	1	53	PPM644M	PULLEY,V BELT,MOTOR 5.125OD,.875B,.188K,11345	1
25	541198	NUT,LPR CAR CRNK CLMP	1	54	RRLE055E10	SPRING,EXT,.055X.5X4	1
26	541452	NUT,THUMB,LPR THD TNSN	1	55	SN62X5924	62X59, Needle SCHMETZ,BX/100	1
27	547670	WASHER SINGER 300UX5	1	56	SSSCM5X16	SCREW,SOCKET CAP M5-0.80X16	100
28	548459	WASHER,STUD	1	57	ZX3825	V BELT, 3/8 X 25"	2
29	559057	FOOT,VIB PRSR	1				1

**3.7. Training**

<b>Activity</b>	<b>Time</b>
<b>Safety Instructions</b>	5 min
<b>Use of the Manual</b>	5 min
<b>INSTALATION</b>	3 Horas.
<b>OPERATION</b> Control Panel	30 min
<b>PREPARATION</b> Thread Threading Tape Threading Tension Adjustment	2 Hr.
Preventive Maintenance 8hrs	15 min
<b>SERVICE</b> <b>Lockout/Tag out Program</b>	5 min
<b>MECANIC</b> General alignment of the table Car Adjustment Head Adjustment	4 Horas
<b>ELECTRIC</b> Ground Main Switch Control Box Electric Transmission Ring Motors Knee Switch Electronic Clutch	3 Horas.
<b>MAINTENANCE</b> Lubrication Preventive Maintenance 8hrs Preventive Maintenance 40 hrs. Preventive Maintenance 160 hrs.	1 Min
Troubleshooting	1 Hora
<b>Total:</b>	<b>15:00</b>

**Participants:**

\_\_\_\_\_

\_\_\_\_\_

\_\_\_\_\_

\_\_\_\_\_

**Instructor:** \_\_\_\_\_ **Date:** \_\_\_\_\_

## Singer® 300UX6 Assembly Drawings & Parts Lists



Atlanta Attachment Company is the exclusive stocking distributor for Singer Tape Edge Sewing Heads and recommended spare parts for Singer Tape Edge machines.

We can also supply proprietary parts in most cases for Cash\*, Spuhl\*, Porter, United\* Tape Edge workstations.

Orders may be placed by:

Phone: 770-963-7369

Fax: 770-963-7641

Email: sales@atlatt.com

® A registered trademark of The Singer Company  
Limited Copyright © 2000 the Singer Company Limited  
All rights reserved through the world.

\*Cash, Spuhl, Porter, and United are the trademarks of their respective companies.

# Upper Shaft Assembly

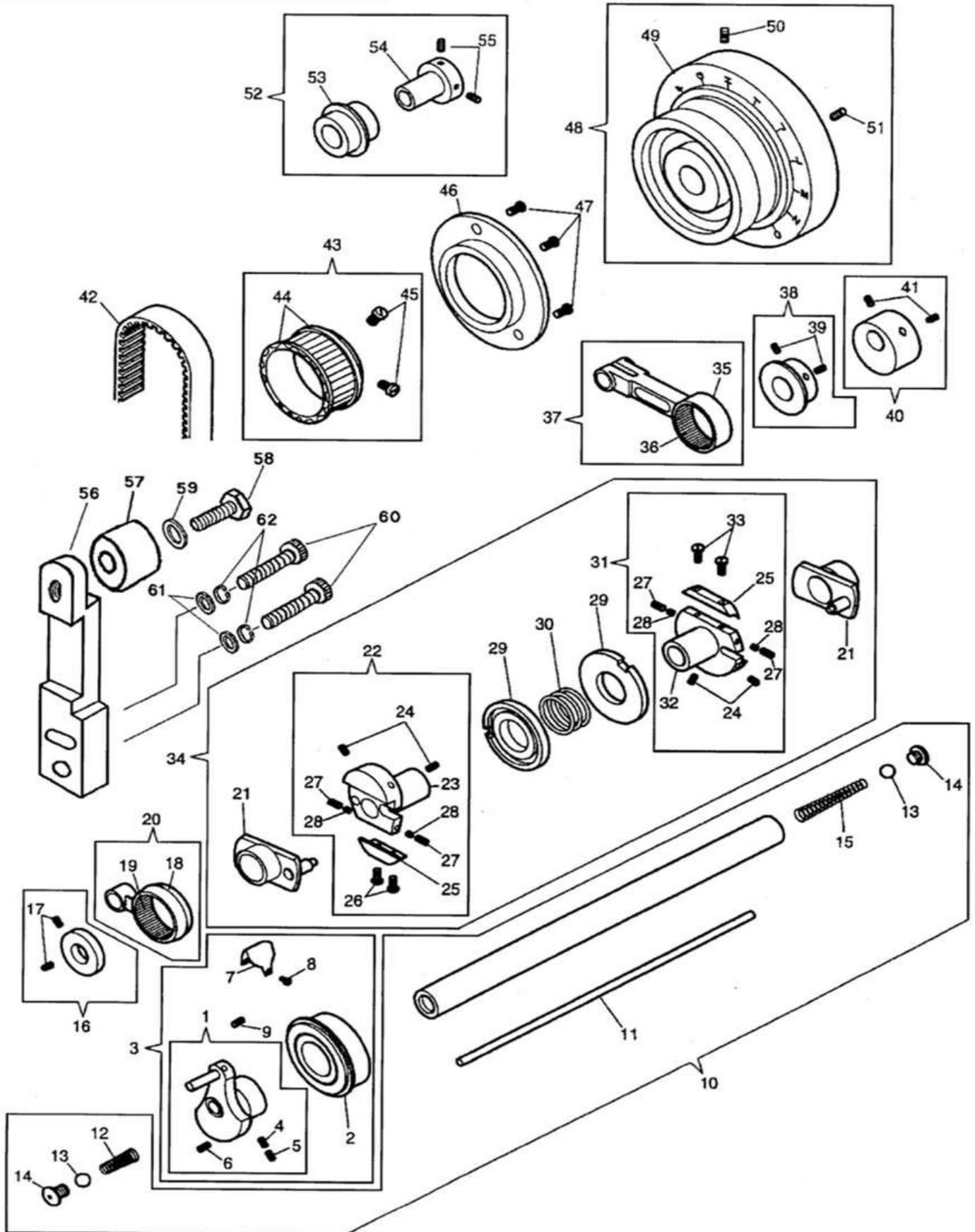

Service Instructions

NO.	PART #	DESCRIPTION	NO.	PART #	DESCRIPTION
1	415138	CRANK, NEEDLE BAR	32	415077	LIFTING ECC FLANGE
2	32848	BEARING	33	374098	SCREW
3	2812239	NEEDLE BAR CRANK COMPLETE	34	415081	ECCENTRIC COMP
4	549024	SCREW	35	268491	LIFTING ECCENTRIC
5	544358	SET SCREW	36	271055	FEED DRIVING CONNECTION NEEDLE
6	500272	NEEDLE BAR CRANK SCREW	37	268491	LIFTING ECC CONN
7	281206	CRANK COVER	38	415086	SPACE COLLAR
8	545205451	SCREW, WHITE	39	414529	SCREW
9	281258	NEEDLE BAR CRANK OIL PACKING	40	281256	BALANCE WEIGHT CPL
10	415128	ARM SHAFT	41	544208005	SCREW
11	268264	ROD, OIL CONTROL	42	268270	CONNECTION BELT
12	415200	SPRING	43	281290	PULLEY
13	268214	BALL, OIL STOP	44	202253	SPRING FLANGE
14	414578	BALL SCREW	45	414546	SCREW
15	268044	SPRING, OIL STOP BALL	46	268004451	HOUSING
16	415308	SPACING COLLAR	47	544336	STUD SCREW
17	414529	SCREW	48	281296467	MACHINE PULLEY (W/414525 & 414
18	271055	FD DRIVE CONN	49	281297467	MACHINE PULLEY
19	271055	FEED DRIVING CONNECTION NEEDLE	50	414525	SCREW
20	267609	FEED DRIVING CONN	51	414526	SCREW
21	267610	FEED DRIVE ECC	52	281294	ARM SHAFT THRUST COLLAR
22	415078	ECCEN FLANGE CPL	53	272142	BALL BEARING
23	415078	ECCENTRIC FRANGE	54	281295001	BED SHAFT THRUST COLLAR
24	414555	SCREW	55	544209005	SET SCREW
25	267623	FRICTION PLATE	56	KE0022	BELT TENSION BRACKET
26	374098	SCREW	57	KE0023	CAM FOLLOWER
27	414557	SCREW	58	KE0074	CAM FOLLOE SCREW
28	241763	PACKING FIBRE	59	KE0082	CAM FOLLOWER SCREW WASHER
29	268065	ECC ADJUSTING DISC	60	414753004	BELT TENSION BRACKET SET SCREW
30	267618	ADJUSTING DISC SPR	61	270 543803005	WASHER
31	415076	LIFT ECC FLANGE CPL	62	270 543805005	WASHER

# Front Assembly Sewing Arm

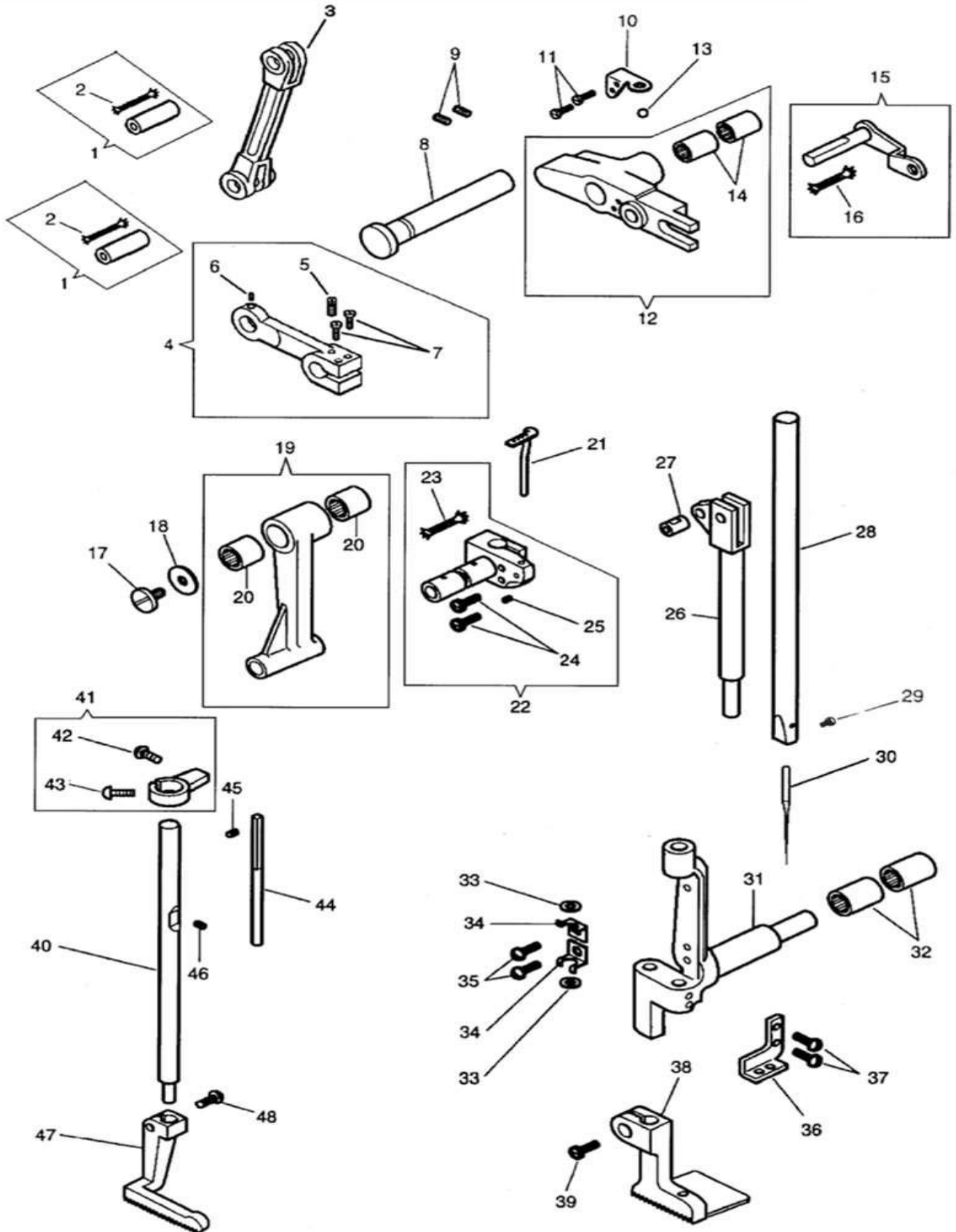

Service Instructions

NO.	PART #	DESCRIPTION	NO.	PART #	DESCRIPTION
1	267617	LINK HINGE PIN	25	414545	SET SCREW
2	268258	PACKING WICK	26	267657	VIB PRESSER BAR
3	267627	LIFTING LINK	27	267658	VIBRATING PRESSER BAR HINGE ST
4	415061	LIFTING CRANK	28	281912	NEEDLE BAR
5	141338	SCREW	29	414519	SCREW
6	141424	SCREW	30		SINGER NEEDLE 62x59 size 23
7	414511	SCREW	31	415045	FRAME, NEEDLE BAR
8	267626	HINGE STUD	32	268029	NEEDLE BEARING
9	544322	SET SCREW	33	268144	N BAR OILING FELT
10	267718	PRESSER BAR SPRING ARM BALL RE	34	268278	OILING FELT HOLDER
11	414548	RETAINER SCREW	35	414522	SCREW
12	415067	Lifting lever	36	268219	THREAD GUIDE
13	276025	BALL, PRESSER BAR SPRING ARM	37	414539	SCREW
14	KE0008	LIFTING LEVER BUSHING	38	KE0069	VIBRATING PRESSER FOOT
15	267631	PR BAR LIFT CRANK	39	414638	SCREW
16	268258	PACKING WICK	40	267628	LIFTING PR BAR
17	414517	SCREW	41	415059	GUIDE BLOCK
18	268139	WASHER	42	414516	SCREW
19	281916	NEEDLE BAR CONNECTING LINK (30	43	414512	SCREW
20	270266	NEEDLE BEARING (GBH68)	44	267907	GUIDE ROD
21	268512	THREAD GUIDE	45	544301	SCREW
22	281914	NEEDLE BAR CONNECTING STUD CPL	46	414530	SCREW
23	202330	OIL WICK	47	559059	LIFTING PRESSER FOOT
24	414511	SCREW	48	414638	SCREW

# External Parts Sewing Arm #1

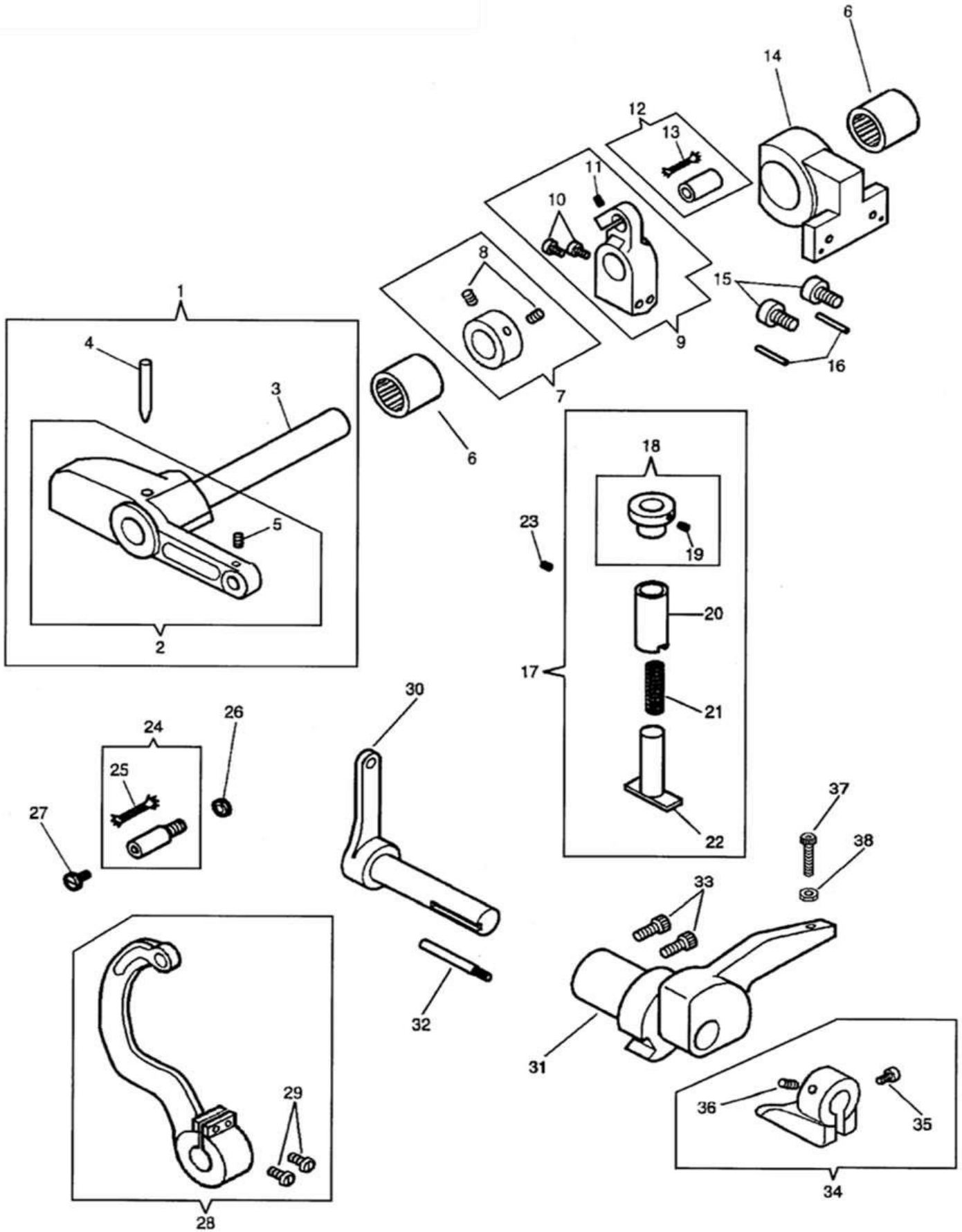

NO.	PART #	DESCRIPTION	NO.	PART #	DESCRIPTION
1	32788	ROCK SHAFT	20	268149	ROCK SHAFT SLEEVE (300UX5)
2	32788	ROCK SHAFT	21	214529	SPRING
3	32789	ROCK SHAFT	22	268148	STUD
4	548035	PIN	23	414527	SCREW
5	141424	SCREW	24	415091	HINGE STUD
6	267110	NEEDLE BEARING, GBH-78	25	268258	PACKING WICK
7	415065	COLLAR COMP	26	541197	NUT
8	504020	SCREW (300UX5)	27	545297	SCREW
9	415069	CONN CRANK	28	415094451	NEEDLE BAR ROCK FRAM DRIVING ARM
10	414509	SCREW	29	414790	SCREW
11	374362	SUBSTITUTION REQUIRED	30	267612	CRANK, FOOT LIFT
12	267617	LINK HINGE PIN	31	267719452	ARM FULCRUM (WHITE)(HIGH LIFT)
13	268258	PACKING WICK	32	414566	SCREW STUD
14	415071451	LIFTING ROCK SHAFT BRACKET	33	350604	SCREW
15	414504	SCREW	34	415122	FT L ARM COMP
16	543841001	PIN	35	414509	SCREW
17	415098	STUD COMP	36	545213	SET SCREW
18	415099	STUD CAP	37	414750004	PRESSER BAR SPRING ARM FULCRUM
19	414528	SCREW	38	541166001	NUT

# Lower Shaft Assembly

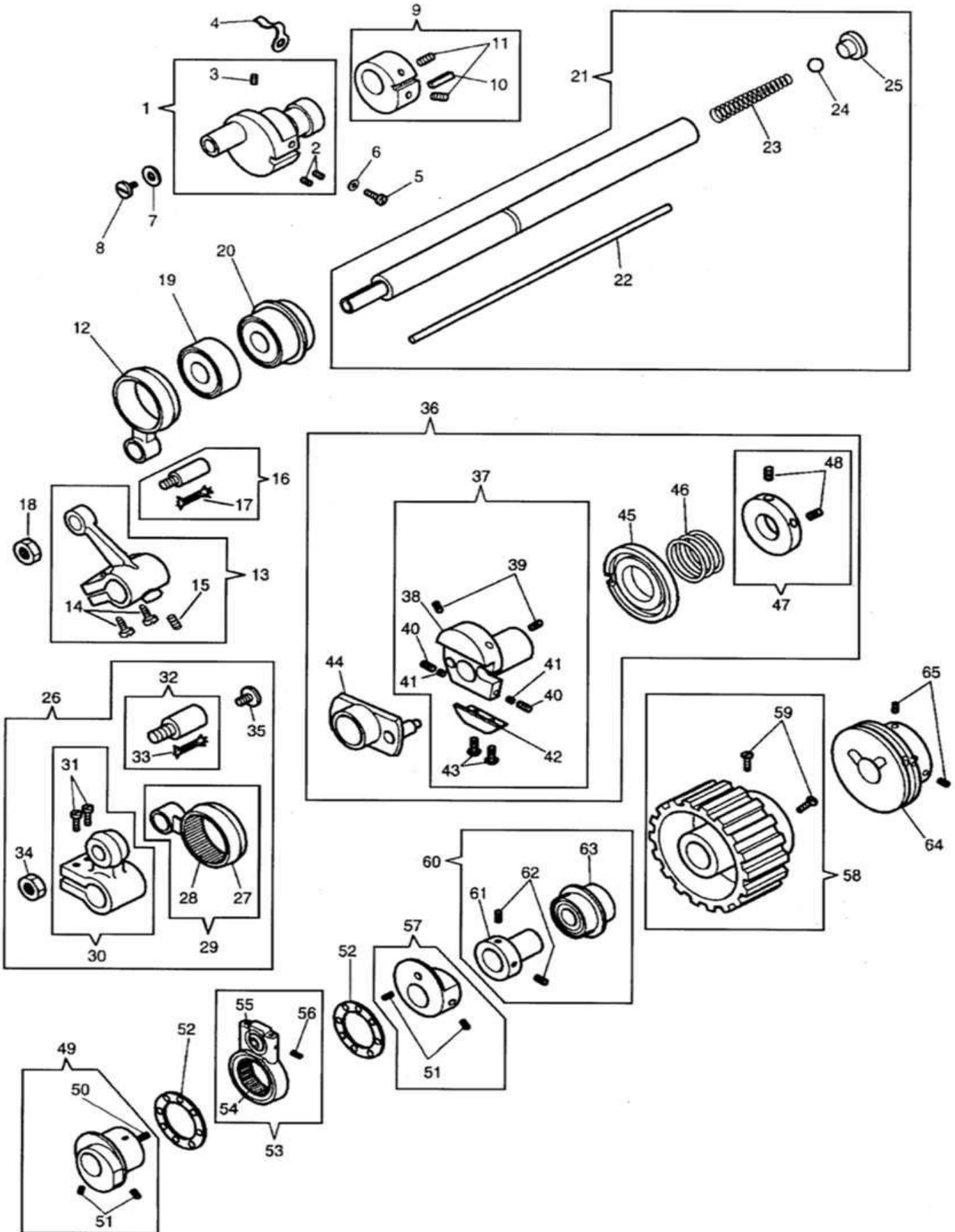

## Service Instructions

NO.	PART #	DESCRIPTION	NO.	PART #	DESCRIPTION
1	415176	DRIVE CRANK	34	541197	NUT
2	374099	SCREW	35	545297	SCREW
3	500264833	LOOPER DRIVING CRANK SET SCREW	36	415082	ECCENTRIC COMP
4	268102	COVER, OIL HOLE	37	415073	FEED DRIVING ECC FLANGE
5	414563	SCREW	38	415073	SUBSTITUTION REQUIRED
6	204925	SPRING STUD WASHER(5)	39	414555	SCREW
7	268139	WASHER	40	414557	SCREW
8	200100	SCREW	41	241763	PACKING FIBRE
9	415210	FEED LIFT ECCEN	42	267623	FRICTION PLATE
10	268077	LUBRICATING PAD	43	374098	SCREW
11	544208005	SCREW	44	267610	FEED DRIVE ECC
12	268074	FD LIFT CONNECTION	45	268065	ECC ADJUSTING DISC
13	415206	ROCK SHAFT CRANK	46	268066	ADJUSTING DISC SPR
14	414511	SCREW	47	412011	SPRING COLLAR
15	414549	SCREW	48	544325	SET SCREW
16	415091	HINGE STUD	49	415187	SPREADER DRIVING ECCENTRIC
17	268258	PACKING WICK	50	543808002	PIN
18	541197	NUT	51	414528	SCREW
19	281216	BED SHAFT BALL BEARING	52	268220	THRUST WASHER
20	281224	BED SHAFT BALL BEARING	53	281246001	SPREADER DRIVING ECC CPL
21	559038	BED SHAFT CPL	54	415368	NEEDLE BEARING (300UX5)
22	268265	CONTROL ROD	55	281248	SPRD DR RCK SHFT SCR STD BALL
23	268044	SPRING, OIL STOP BALL	56	544203001	SCREW
24	268214	BALL, OIL STOP	57	415190	COUNTER BALANCE (300UX5)
25	414578	BALL SCREW	58	281292	BED SHAFT CONNECTION BELT PULL
26	415215	DRIVE SHAFT COMP	59	414546	SCREW
27	271055	FD DRIVE CONN	60	281294	ARM SHAFT THRUST COLLAR
28	271055	FEED DRIVING CONNECTION NEEDLE	61	281295001	BED SHAFT THRUST COLLAR
29	267609	FEED DRIVING CONN	62	544209005	SET SCREW
30	415213	SHAFT CRANK	63	272142	BALL BEARING
31	414511	SCREW	64	KE0038	BED SHAFT PULLEY
32	415091	HINGE STUD	65	544209005	SET SCREW
33	268258	PACKING WICK			

# Front Assembly Sewing Bed

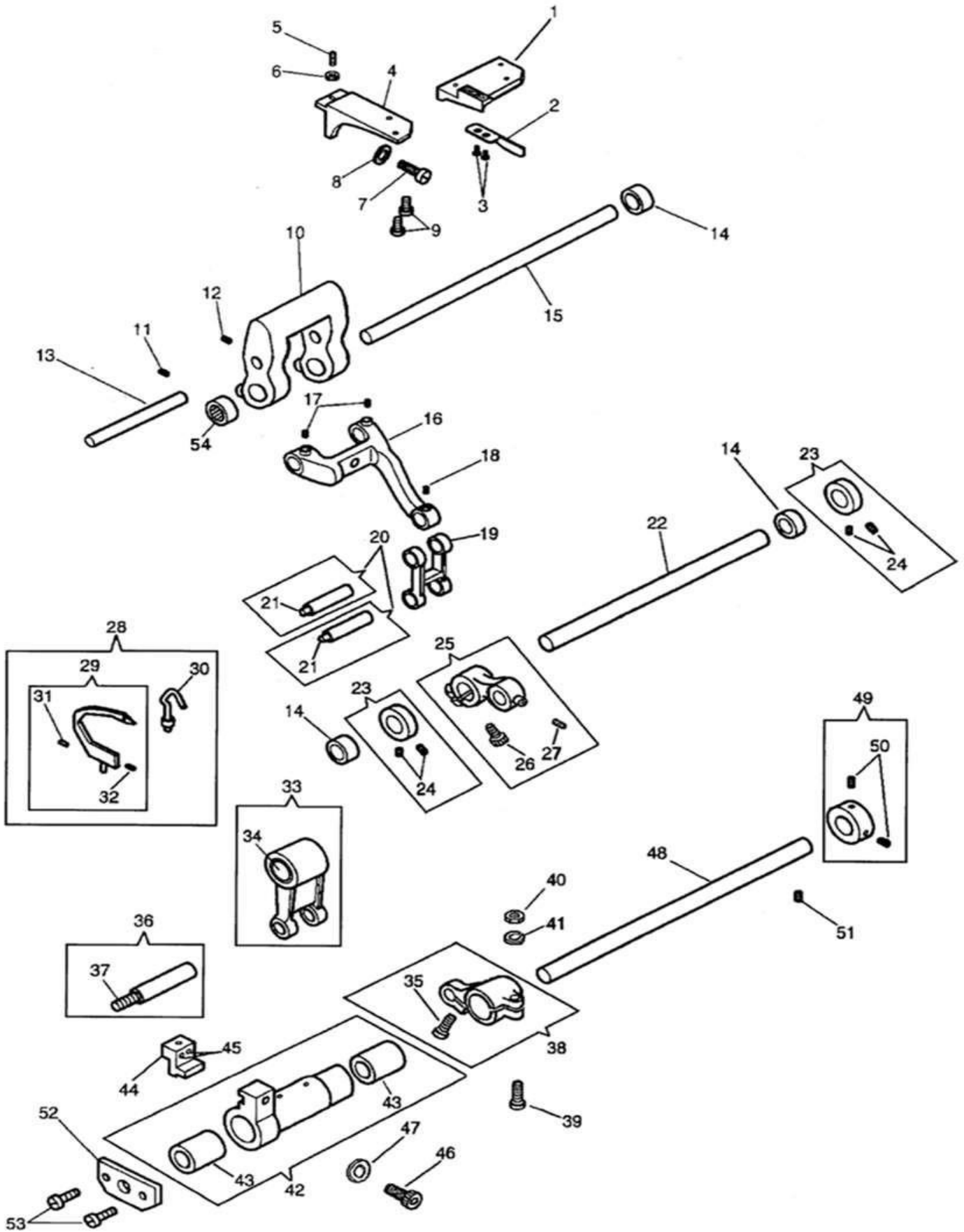

Service Instructions

NO.	PART #	DESCRIPTION	NO.	PART #	DESCRIPTION
1	559061	FEED DOG	28	281208	LOOPER COMPLETE WITH GUARD
2	267665	LOOP DEFLECTOR	29	268382	LOOPER ONLY (ORDER 281207 FOR
3	412176	LINK, CONN CRANK	30	281207	NEEDLE GUARD
4	559064	FEED DOG SHANK	31	141478	SCREW
5	414559	SCREW	32	141494	SCREW
6	541200	LOCK NUT	33	281223	LOOPER DRIVING CONNECTION CPL
7	414750002	SCREW	34	415500	BUSHING
8	543804004	WASHER	35	414516	SCREW
9	374107003	SCREW	36	268208	CRANK HINGE PIN
10	559049	FEED DRIVE ROCK FRAME	37	268258	PACKING WICK
11	549024	SCREW	38	415174	LOOPER CARR CR CPL
12	500264833	FEED DRIVING ROCK FRAME SET SCREW	39	415292	CLAMPING STUD
13	559051	FEED BAR HINGE PIN	40	541198	NUT
14	415297	BUSHING	41	548459	WASHER
15	268070	SHAFT, DRIVE ROCK	42	559041	LOOPER CARRIER
16	559045	FEED BAR	43	415500	BUSHING
17	270 544204001	SCREW	44	559055	LOOPER HOLDER CPL
18	545213	SET SCREW	45	414558	SCREW
19	268078	FEED LIFTING LINK	46	414750002	SCREW
20	268079	LINK HINGE PIN	47	543804004	WASHER
21	268258	PACKING WICK	48	269617	CARRIER SHAFT
22	559052	FEED LIFTING ROCK SHAFT	49	415172	SHAFT COLLAR
23	415065	COLLAR COMP	50	270 544204001	SCREW
24	504020	SCREW (300UX5)	51	544209003	SCREW
25	415204	CRANK	52	559044	LOOPER CARRIER SHAFT SUPPORTIN
26	414501	SCREW	53	200100	SCREW
27	545213	SET SCREW	54	415297	NEEDLE BEARING

# Cross Shaft in Sewing Bed

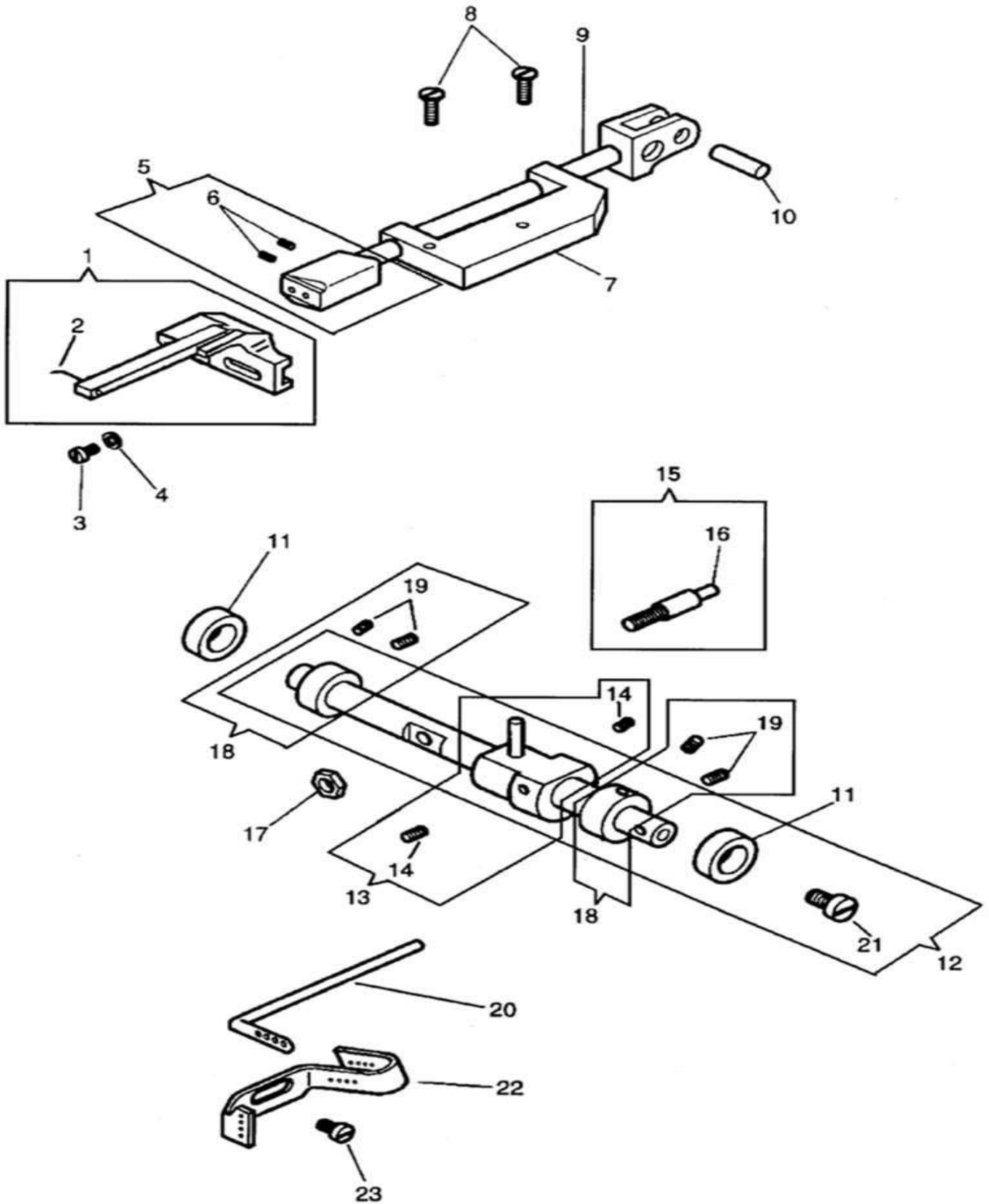

<b>NO.</b>	<b>PART #</b>	<b>DESCRIPTION</b>
1	281975	SPREADER
2	268162	SPREADER POINT
3	414552	SCREW
4	547670	WASHER
5	415196	SPREADER HOLDER
6	414529	SCREW
7	268184	SPREADER BAR BRACKET
8	414524	SCREW
9	559065	SPREADER BAR
10	268190	SPREADER DRIVE PIN
11	415297	BUSHING
12	415389	ROCK SHAFT
13	415194	CRANK COMP
14	270 544204001	SCREW
15	281249	SPREADER DRIVING ROCK SHAFT SC
16	32825	OIL WICK
17	545424	NUT
18	415065	COLLAR COMP
19	504020	SCREW (300UX5)
20	268052	LOOPER TAKE UP ROD
21	545385	SCREW
22	269619	THREAD GUIDE
23	414510	SCREW

# External Parts Sewing Arm #2

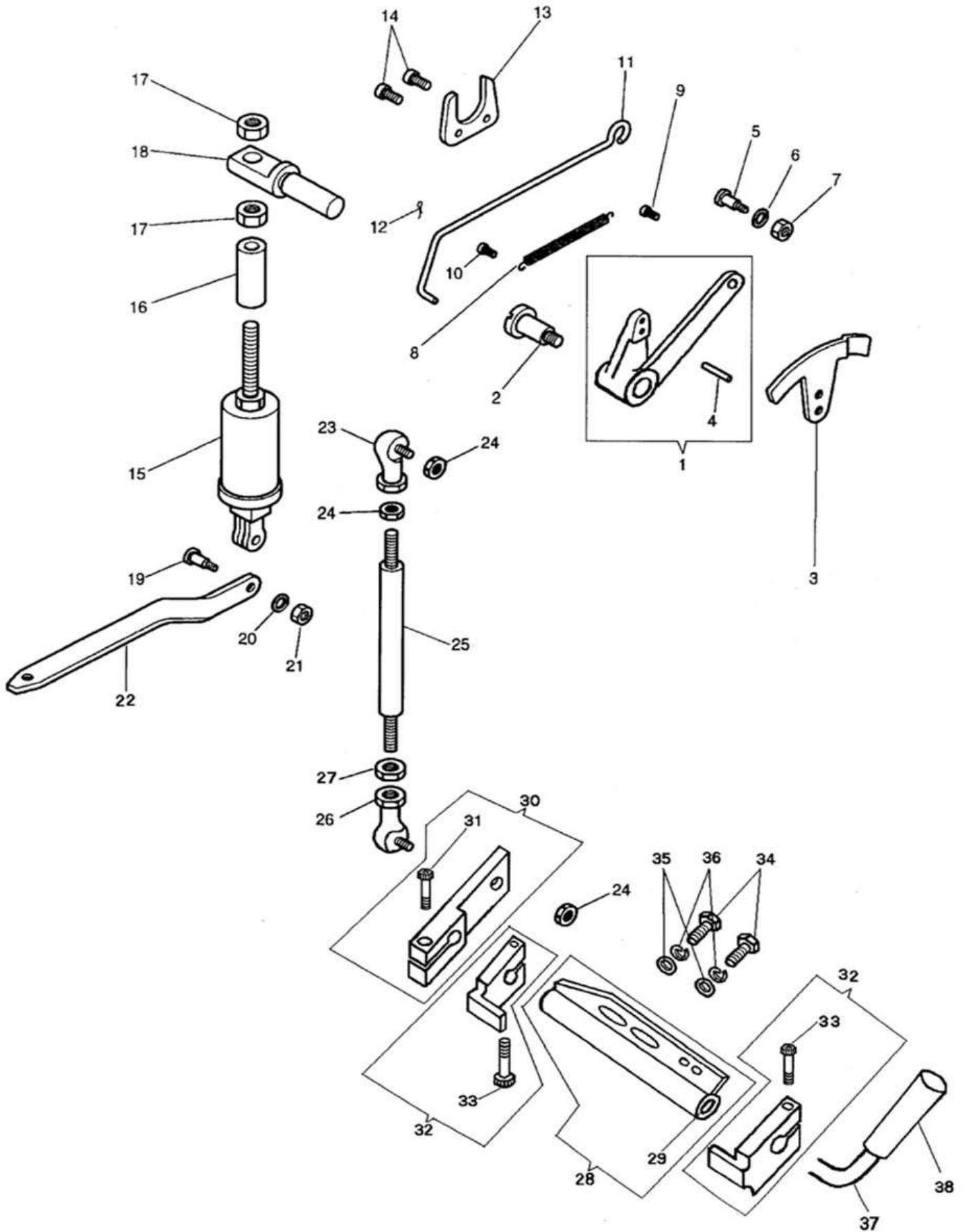

NO.	PART #	DESCRIPTION	NO.	PART #	DESCRIPTION
1	KE0085	FOOT LIFTER LEVER	20	548154	SCREW WASHER
2	201363	SCREW 300W	21	545405	NUT
3	267707	RELEASING PLATE	22	267738	PR BAR SPR ARM
4	543850001	PLATE PIN	23	412373	CONNECTION (UPPER)
5	414577	HINGE SCREW	24	541166001	NUT
6	543804004	WASHER	25	559068	LIFTING ROD
7	541166003	NUT	26	559067	LIFTING ROD CONNECTION (LOWER)
8	204348	SWITCH SPRING	27	414774	NUT
9	414570	SCREW	28	KE0026	FOOT LIFT PIVOT COMPLETE
10	544336	STUD SCREW	29	KE0030	BUSHING
11	267704	LIFTER LEVER ROD	30	KE0083	FOOT LIFT LEVER COMPLETE
12	248423	COTTER PIN	31	414753004	BELT TENSION BRACKET SET SCREW
13	267650	RETAINER	32	KE0084	STOP COLLAR COMPLETE
14	545205451	SCREW, WHITE	33	414750004	PRESSER BAR SPRING ARM FULCRUM
15	415106	PRESSER BAR SPRING HOUSING ASS	34	544499072	SCREW
16	559077	PRESSER BAR SPRING HOUSING COL	35	270 543803005	WASHER
17	541198	NUT	36	270 543805005	WASHER
18	267714	HOUSING SUPPORT	37	KE0034	PIVOT ARM
19	414567	HINGE SCREW	38	KE0035	HANDLE

# External Parts Sewing Arm #3

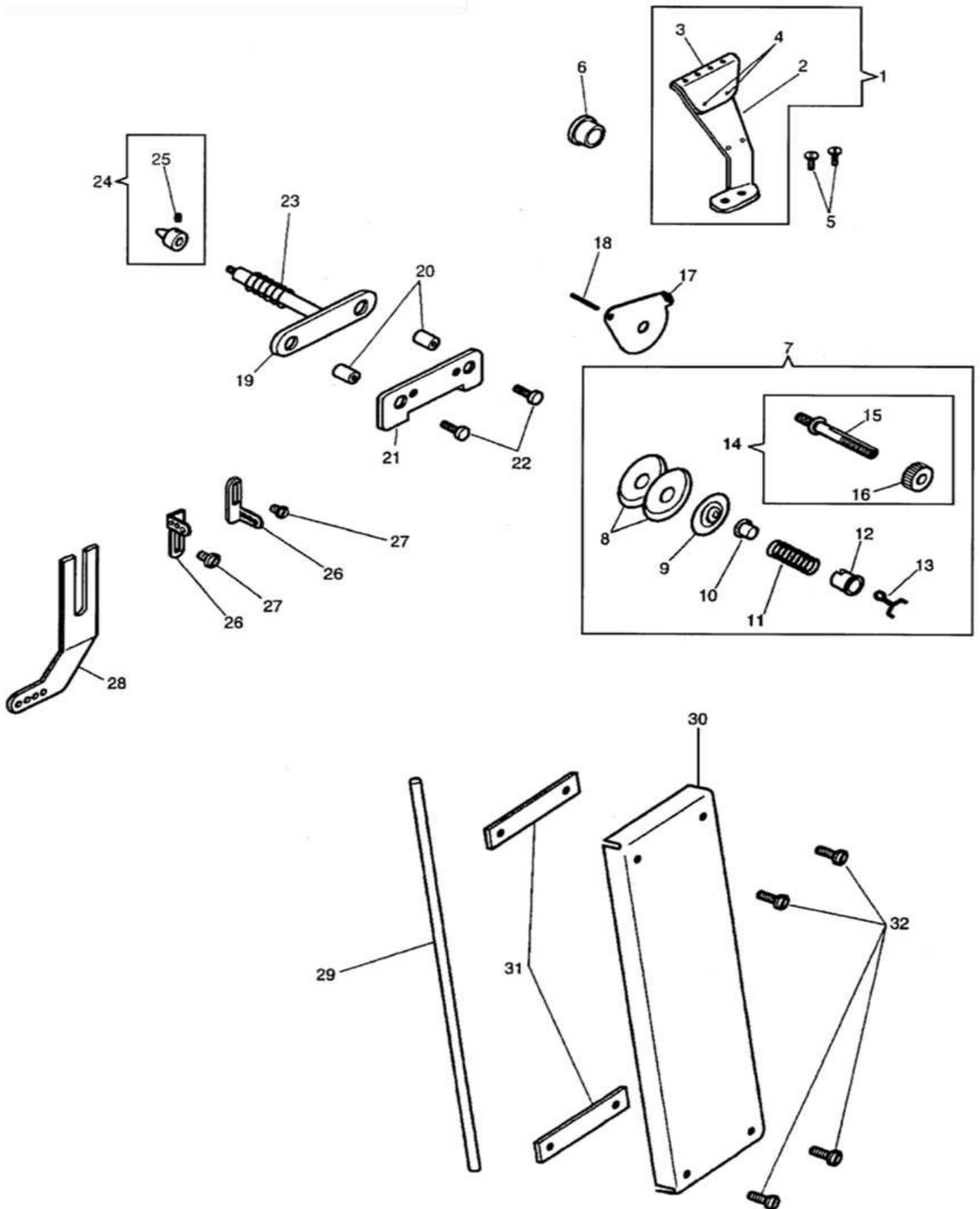

NO.	PART #	DESCRIPTION
1	268506	TH GUIDE BRACKET
2	268111	LOOPER BRACKET
3	268505	LOOPER TH GUIDE
4	50169	SCREW (5)
5	414537	SCREW
6	544875	PLUG
7	267971	THREAD TENSION
8	HA046072	TENSION DICS
9	32572	TENSION DISC (5)
10	59538	SPRING BUSHING
11	131741	TENSION SPRING
12	143657	BUSHING
13	143658	LOCKING SPRING
14	59539	TENSION SCREW STUD
15	59539	TENSION SCREW STUD
16	51570	NUT
17	54279	THREAD GUIDE
18	226206	LATCH SPRING PIN
19	415357	TENSION RELEASER
20	543853003	NEEDLE THREAD TENSION BRACKET
21	268167	TENSION BRACKET
22	544336	STUD SCREW
23	204365	SPRING
24	415252	RELEASER CAP
25	504048	SCREW
26	268513	N THREAD GUIDE
27	414514	SCREW
28	268312	THREAD GUIDE
29	268123	THREAD TUBE
30	415342451	LOOPER THREAD TUBE COVER
31	268500	GASKET
32	414639	GUIDE SCREW

# External Parts Sewing Arm #4

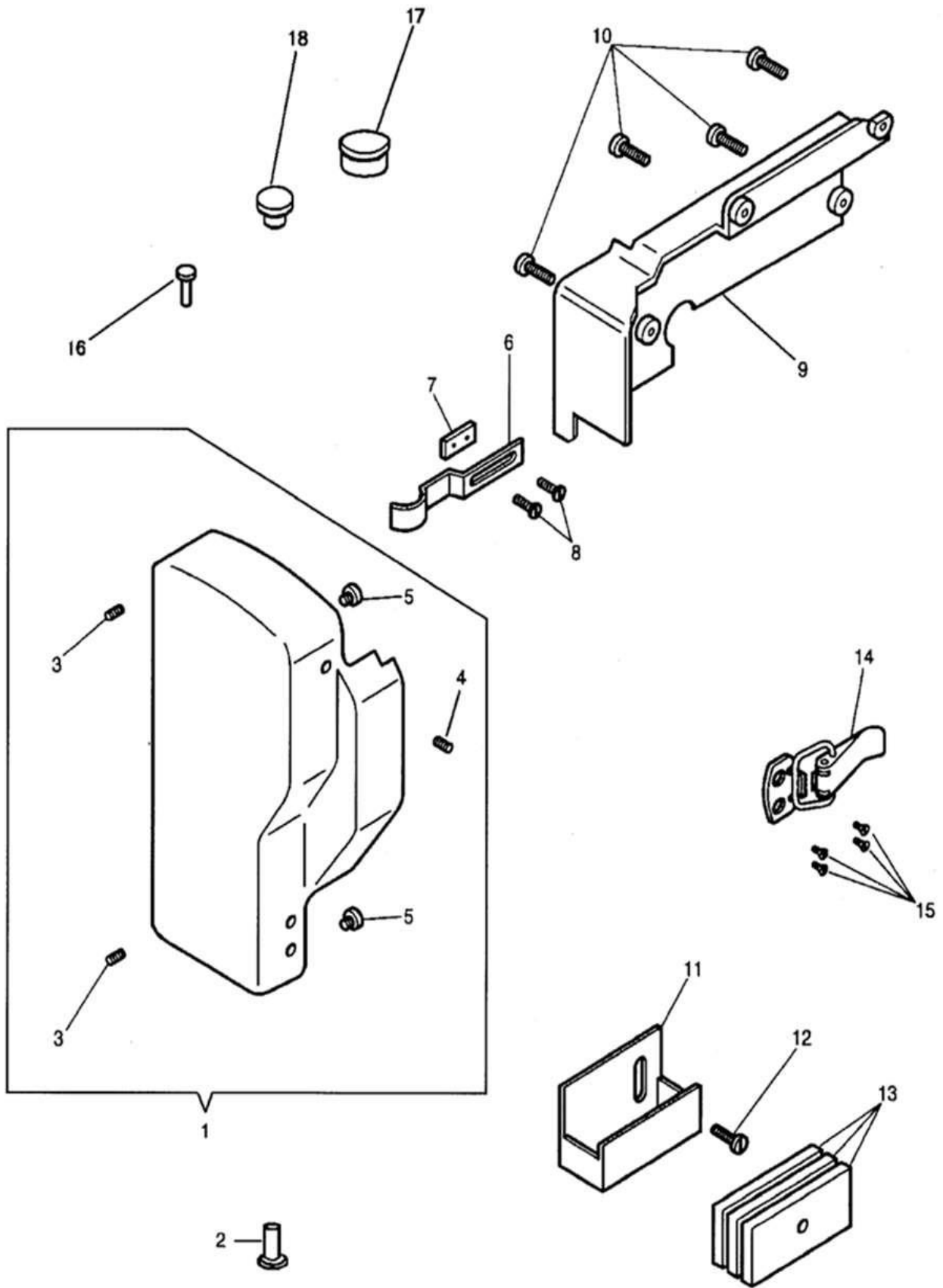

NO.	PART #	DESCRIPTION
1	KE0021	FACE PLATE (WITH 268033)
2	268330	FACE PLATE HINGE STUD
3	544053	SET SCREW
4	268033	LOCK STUD
5	228661	COVER CUSHION
6	268032	LOCK SPRING
7	415016	SPRING PLATE
8	414534	SCREW
9	KE0072	ARM SIDE COVER
10	545295	SCREW
11	267656452	THREAD LUBRICATOR
12	545385	SCREW
13	236957	OIL PAD, THREAD LUBRICATOR (FEL
14	559032	FACE PLATE LOCKER
15	374397002	FACE PLATE LOCKER SCREW
16	KE0007	FACE PLATE HINGE STUD
17	544875	PLUG
18	502986	PLUG

# External Parts Sewing Arm #5

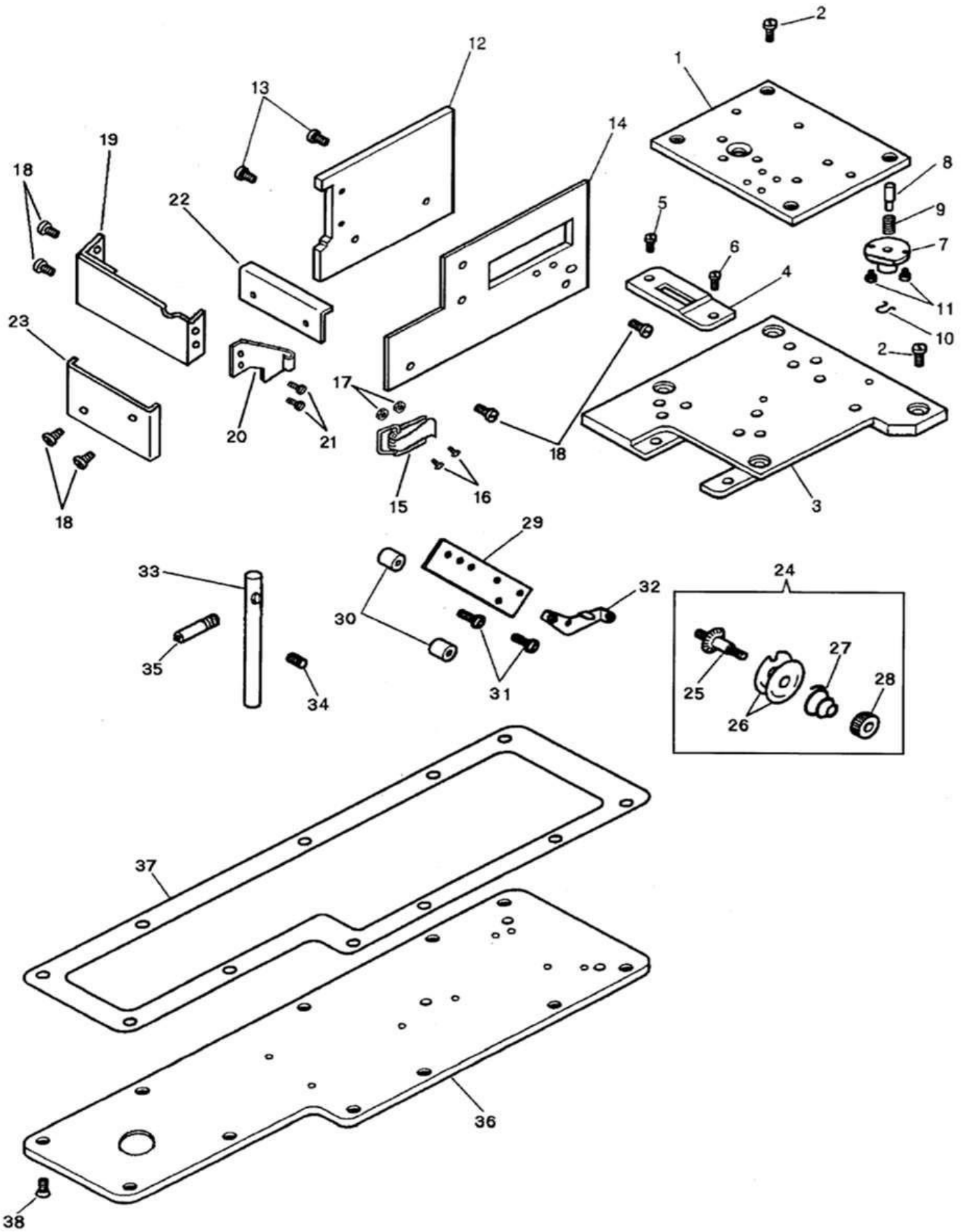

Service Instructions

NO.	PART #	DESCRIPTION
1	KE0073	BED PLATE (RIGHT)
2	414508	SCREW
3	KE0037	BED PLATE (LEFT)
4	559060	THROAT PLATE
5	374107001	THROAT PLATE SCREW (BACK)
6	200100	SCREW
7	KE0075	FEED REGULATING STUD SOCKET
8	268081	STUD, FEED REG
9	270026	FEED REG STUD SPR
10	240245	RETAINING SPRING, (5PK)
11	545249452	FEED REGULATING STUD SOCKET SC
12	559075	BED COVER (BACK)
13	414520	SCREW
14	KE0068	BED COVER (FRONT)
15	KE0044	BED COVER (FRONT) LOCKER
16	270 544211051	STRIKER SCREW
17	541164001	NUT
18	544252	SET SCREW (300UX5)
19	KE0039	LOOPER COVER
20	KE0042	SNAP HOOK LATCH
21	544252	SET SCREW (300UX5)
22	559074	BED COVER (LEFT)
23	KE0043	END COVER
24	415294	TENSION COMP
25	415291	TENSION STUD
26	412203	TENSION DISC
27	10148	SPRING
28	541452	NUT
29	415255	TENSION BRACKET
30	543853003	NEEDLE THREAD TENSION BRACKET
31	414532	SCREW
32	268333	THREAD GUIDE
33	52239	LOOPER THREAD GUIDE
34	270 544211052	SCREW
35	559078	LOOPER THREAD GUIDE (PIPE)
36	KE0005	BOTTOM PLATE
37	559034	BOTTOM PLATE GASKET
38	414533	SCREW

## Accessories

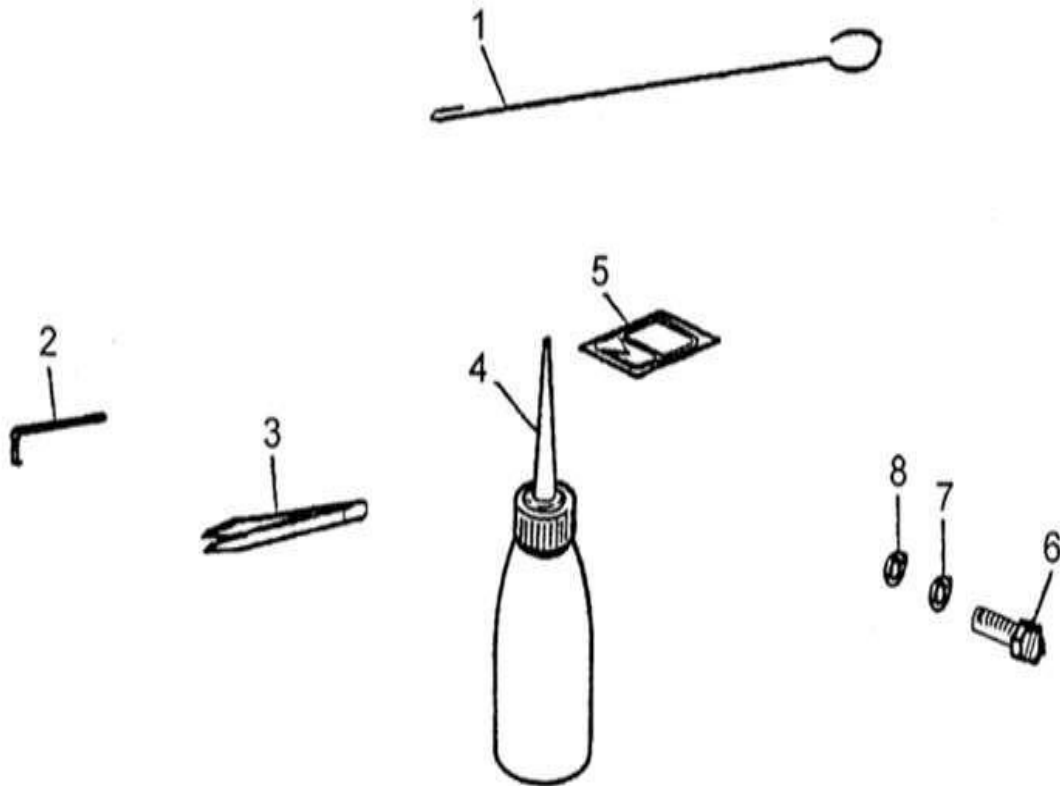

NO.	PART NO.	DESCRIPTION
1	170 415377	THREADER WIRE
2	170 021887	WRENCH
3	270 BENTTWEEZER	BENT TWEEZERS, METAL
4	170 413448001	OILER
5	160 411201120	NEEDLE, 62X59
6	170 KE0015	BOLT
7	170 KE0016	WASHER
8	170 KE0017	SPRING WASHER

## COLUMN ASSEMBLY / ADJUSTMENT INSTRUCTIONS

- 1) Position the column assembly (item A) with the lower edge below the bottom of the slide support bracket (item B). DO NOT ADJUST WITH THE COLUMN OR TABLE IN THE "UP" POSITION.
- 2) Loosen the (8) screws (item C) holding the slide support bracket (item B) and the jam nuts (item D) for the top and bottom adjustment screws (item E).
- 3) Tighten or loosen the (4) upper and (4) lower adjustment screws (item E) as required to put pressure on the column assembly (item A) and align it in the support column. NOTE: EXCESSIVE PRESSURE WILL CAUSE BINDING AND PREMATURE FAILURE OR WEARING OF PARTS. Apply only the minimum amount of pressure required to reduce the rotational movement of the table to an acceptable level.
- 4) Tighten the (8) top and (8) bottom support screws (item C).
- 5) Bolt the tabletop to the column and add shims if necessary to level the table parallel to the frame.

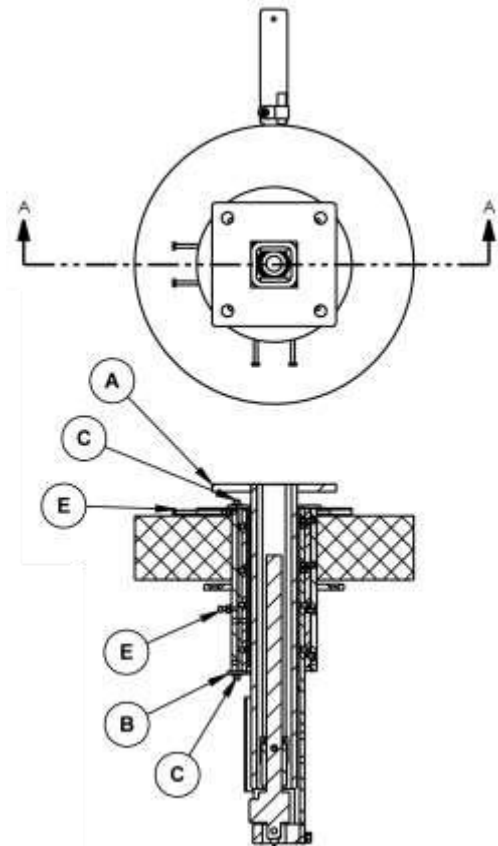
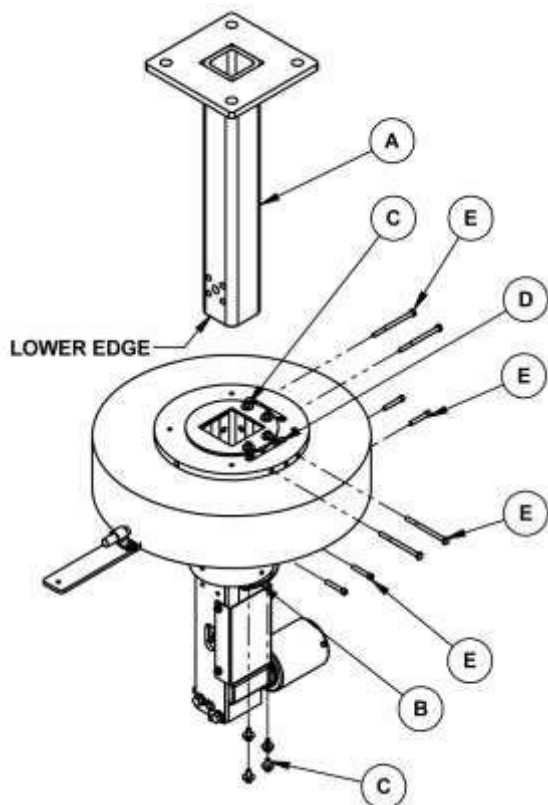

## Assembly Drawings & Parts Lists

The materials contained herein are confidential and proprietary information of Atlanta Attachment Company. In addition to any confidentiality and non-disclosure obligations that currently exist between you and Atlanta Attachment Company, your use of these materials serves as an acknowledgment of the confidential and proprietary nature of these materials and your duty not to make any unauthorized use or disclosure of these materials.



**One-Stop Shopping**  
For Expendable Replacement Parts for AAC & Other Bedding Equipment Suppliers  
Toll Free: **1-866-885-5100**  
[www.atlantapartsdepot.com](http://www.atlantapartsdepot.com) • [sales@atlantapartsdepot.com](mailto:sales@atlantapartsdepot.com)

# 11345-2C Tape Edge Workstation

AAC Drawing Number 9008850 Rev 2

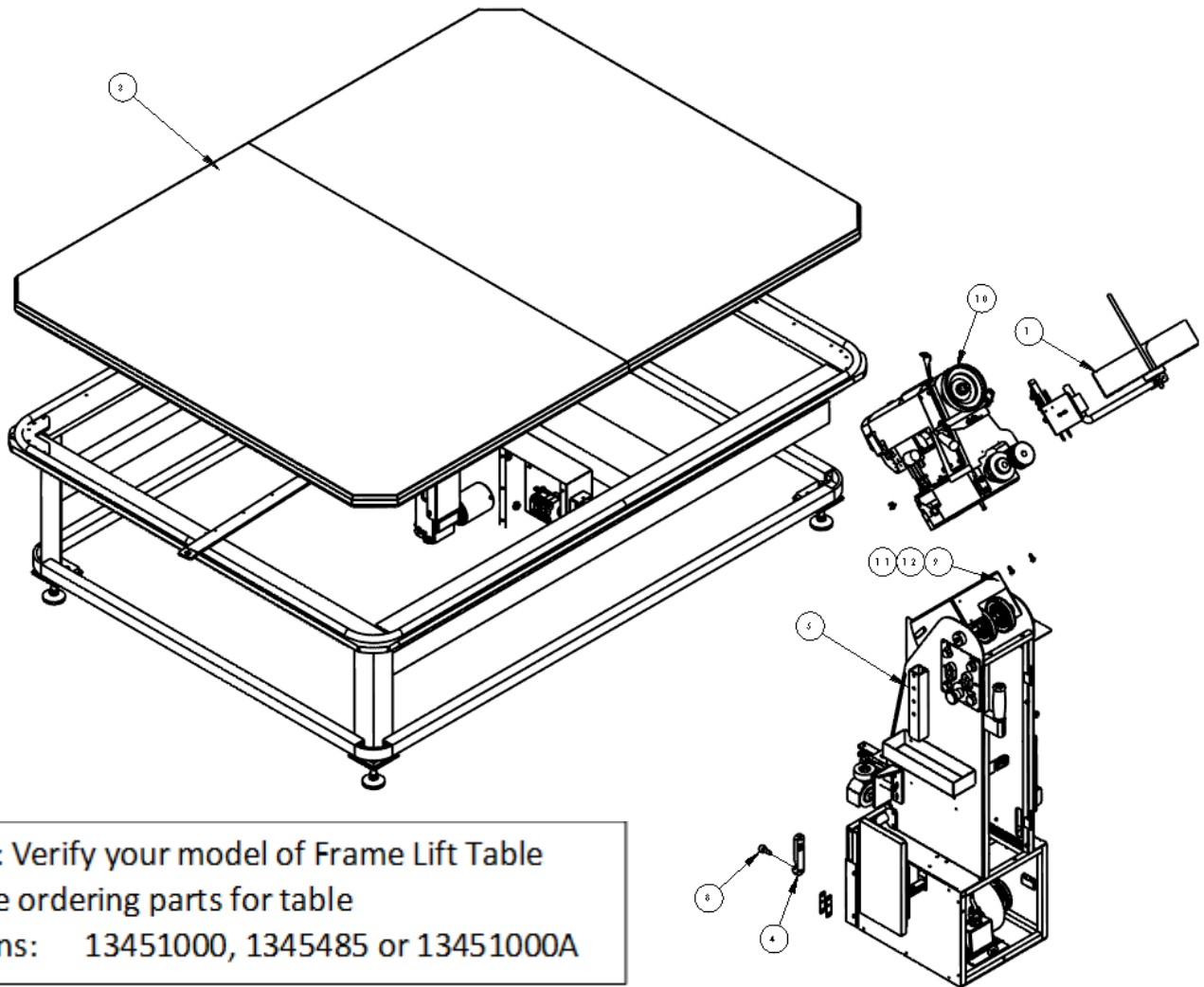

**Note :** Verify your model of Frame Lift Table before ordering parts for table  
**Options:** 13451000, 1345485 or 13451000A

ITEM NO.	QTY.	PART NUMBER	DESCRIPTION
1	1	1345-025	TAPE ROLL HOLDER ASSY
2	1	1345-2CWD	WIRING DIAGRAM
3	1	13452500A	TABLE ASSY, COMPLETE
4	1	13453428	MOUNT, CAM FOLLOWER
5	1	1345474	CARRIAGE ASSEMBLY
6	1	1345LAB1	LABEL
7	1	1345LAB2	LABEL, TABLE, DONT SIT/STAND
8	1	MMCCF3/4SB	CAM FOLLOWER, 3/4 DIA
9	3	SSHCO1048GR8	1/4-20 X 3/4 HEX CAP
10	1	SSIN-300UX6A	HEAD, ACME&CASH, TAPE EDGE
11	3	WWFS1/4	WASHER, FLAT, SAE, 1/4
12	3	WWL1/4	WASHER, LOCK, 1/4
13	1	13453060	DOOR, CARRIAGE, REAR

Service Instructions

SIN-300UX6A Tape Edge Head (11345-2B and 2C)

AAC Drawing Number 9001121 Rev 1

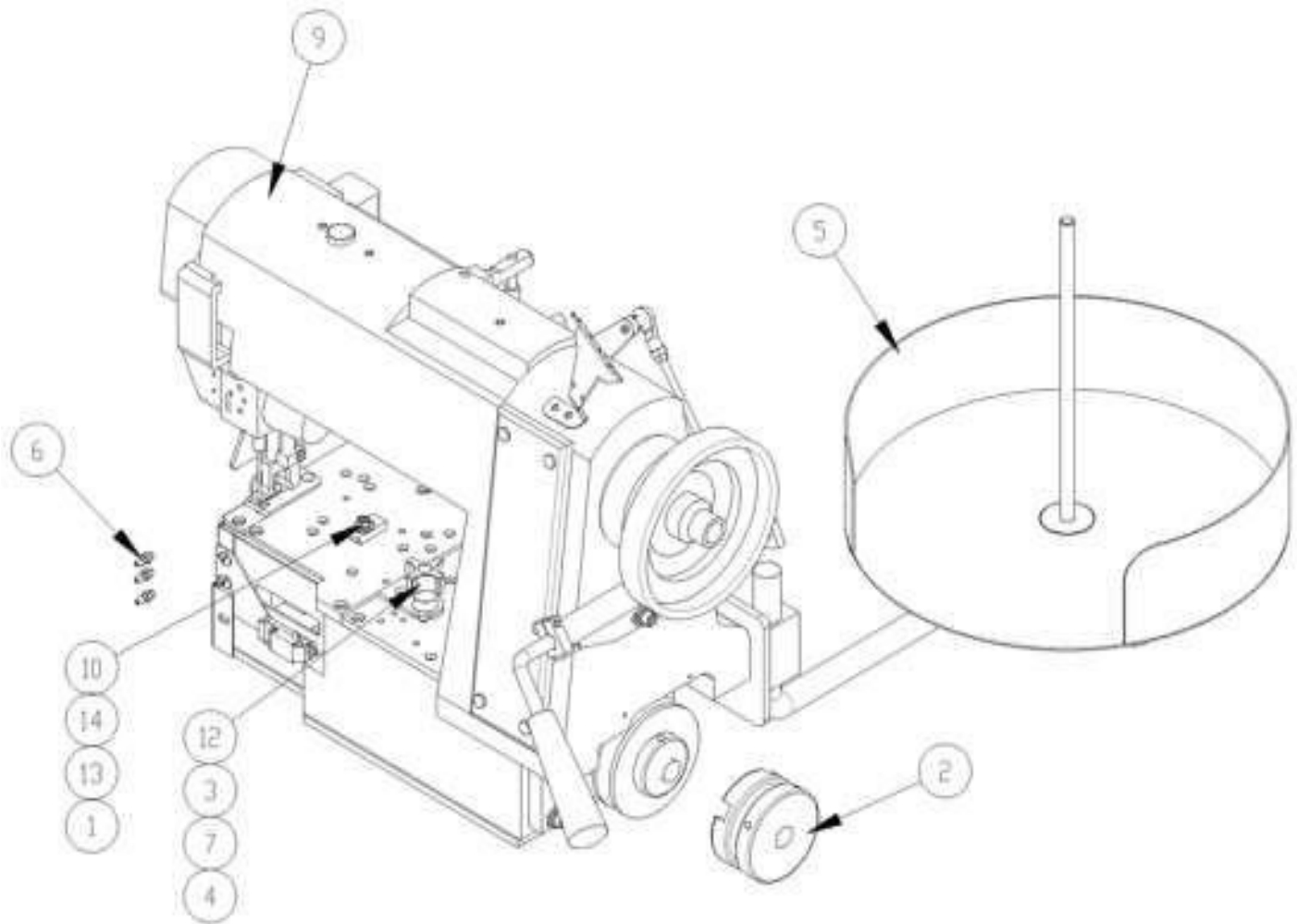

NO.	QTY.	PART#	DESCRIPTION
1	1	1345-004	BLOCK, STOP FOR
2	AR	1345-006S	PULLEY,300UX5,SPUHL
3	1	1345-009A	SPACER,1/8X1X1.8L
4	1	1345-009B	SLEEVE,.25 ODX.19
5	1	1345-025	TAPE ROLL HOLDER
6	3	AAF11752-3	BRASS BARB FOR
7	1	RRBEEHIVEH	SPRING,HEAVY
8	1	SSAS020048	SCREW,ALLEN
9	1	SSIN-300UX6	HEAD,MOD,GEN,TAPE
10	1	SSSC95040	10-24 X1, SOC CAP
11	1	TA2351004-R0	RUBBER PLUG
12	1	TTCL1APPK1	PLASTIC KNOB, #10-32
13	1	WWFS10	WASHER, FLAT, #10,
14	1	WWL10	WASHER,LOCK,#10

Service Instructions

**SSIN-300UX6M Modified Sewing Head Assembly**

AAC Drawing Number 9002945 Rev4

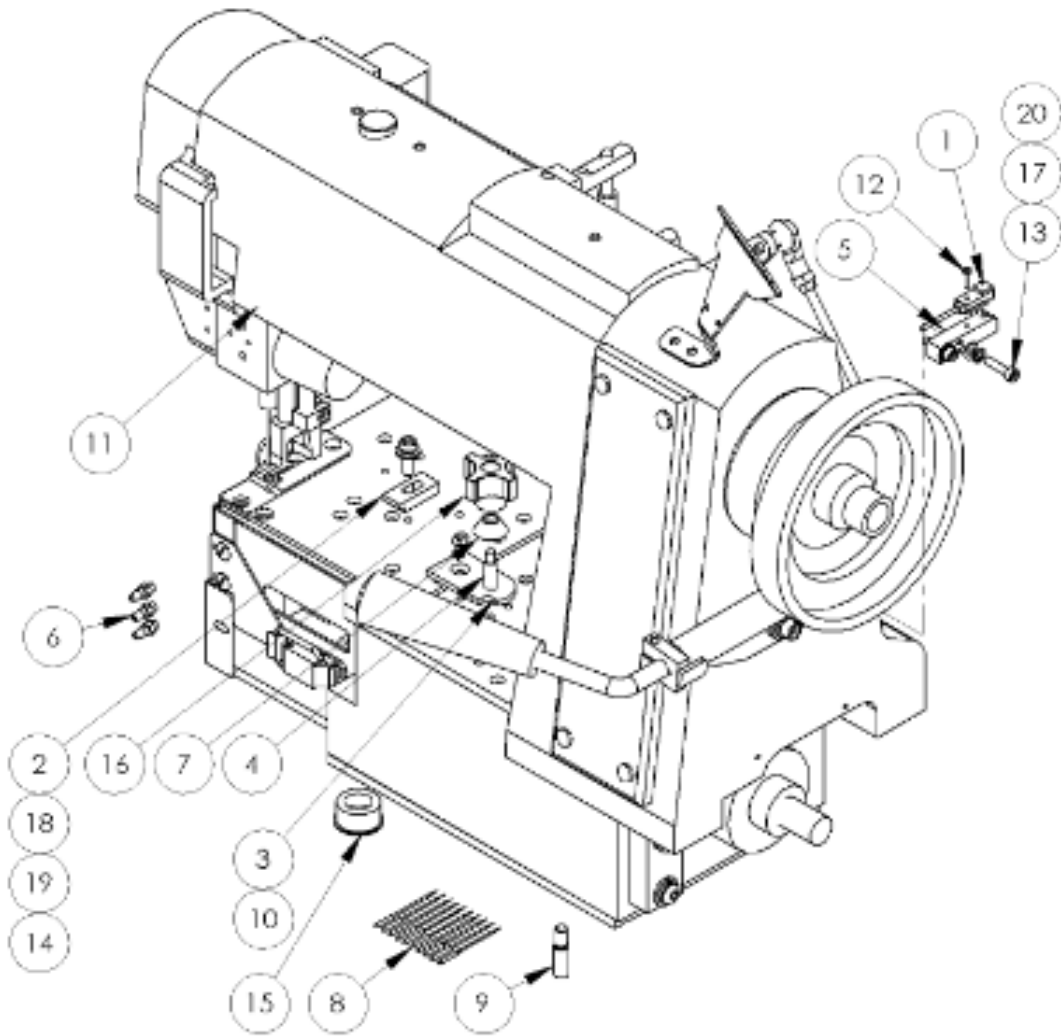

ITEM	QTY.	PART NUMBER	DESCRIPTION	ITEM	QTY.	PART NUMBER	DESCRIPTION
1	1	1278-7055D	PROX SWITCH W/PLUG,12"	11	1	SSIN-300UX6	HEAD,MOD,GEN,TAPE EDGE
2	1	1345-004	BLOCK, STOP FOR BINDER	12	1	SSPS50024	2-56 X 3/8 PAN HD SC
3	1	1345-009A	SPACER,1/8X1X1.8L	13	2	S SSC90040	8-32 X 5/8 SOC CAP SC
4	1	1345-009B	SLEEVE,.25 ODX.19 IDX.5LS	14	1	S SSC95040	10-24 X5/8, SOC CAP
5	1	1345-505	BLOCK, FOOT UP SENSOR	15	1	TA2351004-R0	RUBBER PLUG
6	3	AAF11752-3	BRASS BARB FOR AIRLINE.	16	1	TTCL1APPK1	PLASTIC KNOB, #10-32
7	1	RRBEEHIVEH	SPRING,HEAVY BEEHIVE	17	2	WWB5/32	WASHER, FLAT, 5/32", BRAS
8	10	SN62X59	NEEDLE,SIZE 24/180	18	1	WWFS10	WASHER, FLAT, #10, SAE
9	1	SSAS020048	SCREW,ALLEN SHOULDER	19	1	WWL10	WASHER,LOCK,#10
10	1	S SFC90024	8-32 X 3/8 FL ALN CAP	20	2	WWSI8	WASHER,INT. TOOTH, #8

**1345-500 Foot lift Pivot Link Assembly**

AAC Drawing Number 192500B Rev 7

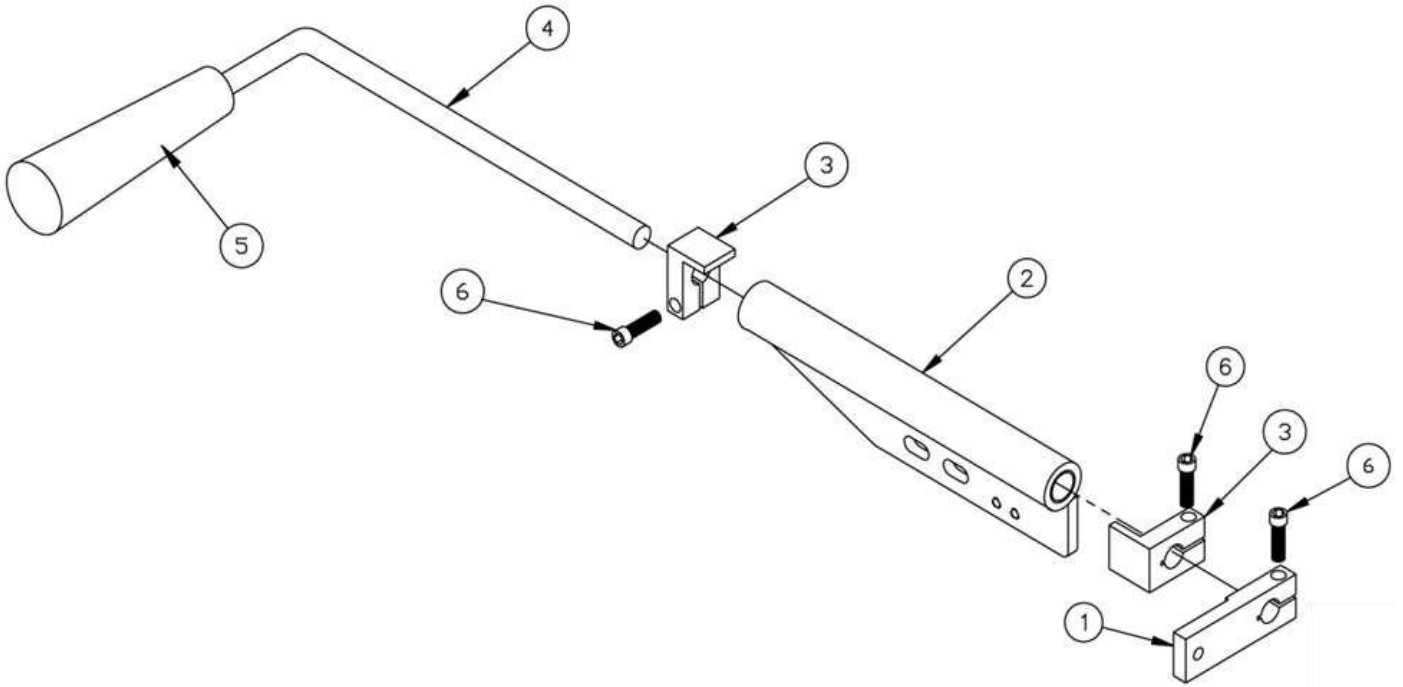

NO.	QTY	PART #	DESCRIPTION
1	1	1349518	Foot Lift Lever
2	1	1345-503	Pivot Bracket
3	2	1345077	Stop Clamp
4	1	1345-504	Pivot Arm
5	1	MMBTH-2	Handle
6	3	SSSC98048	Screw, Socket Cap
7	AR	1345-500INS	Instructions

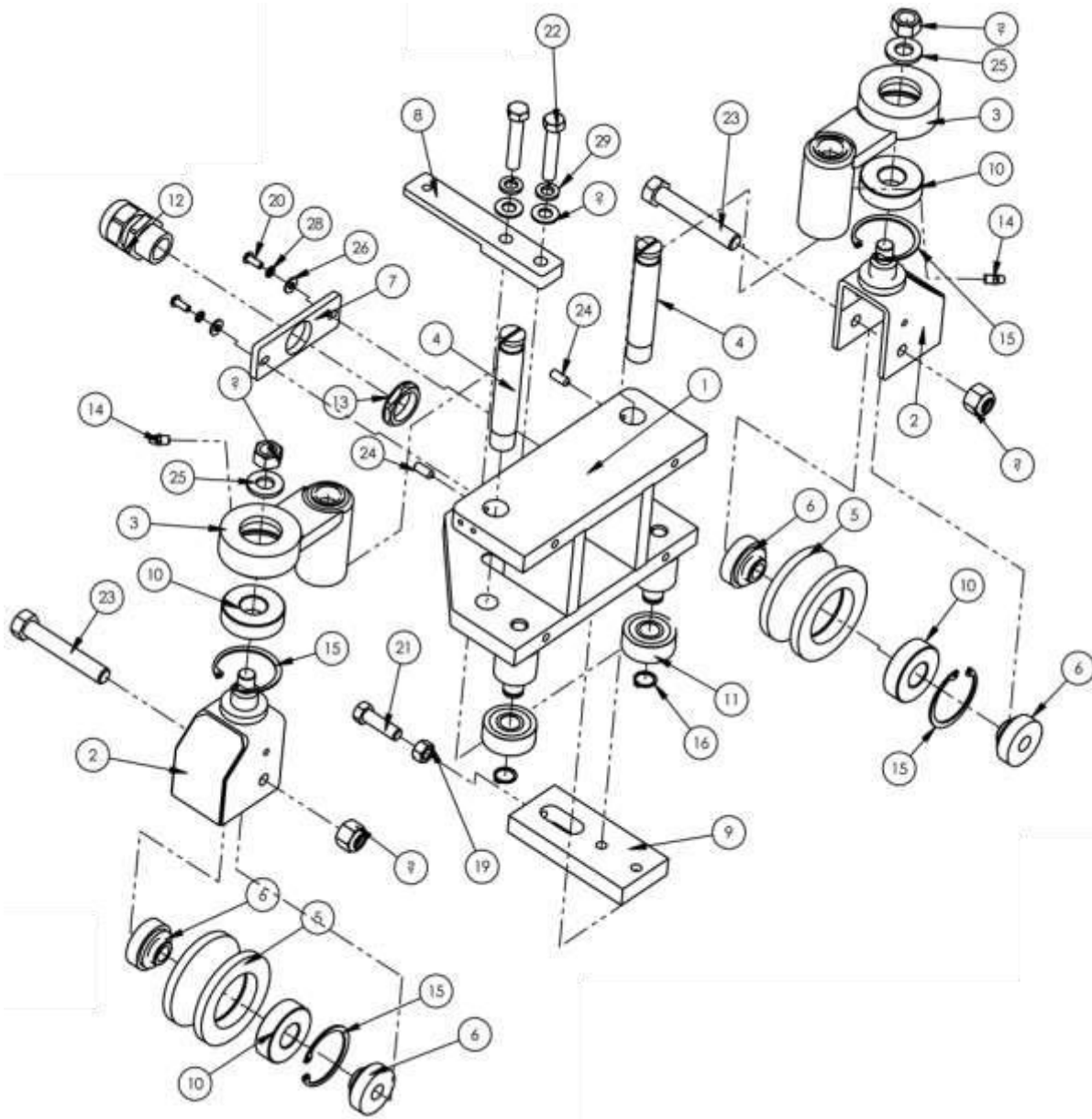

# 1345-025 Tape Roll Holder

AAC Drawing Number 9001100 Rev 7

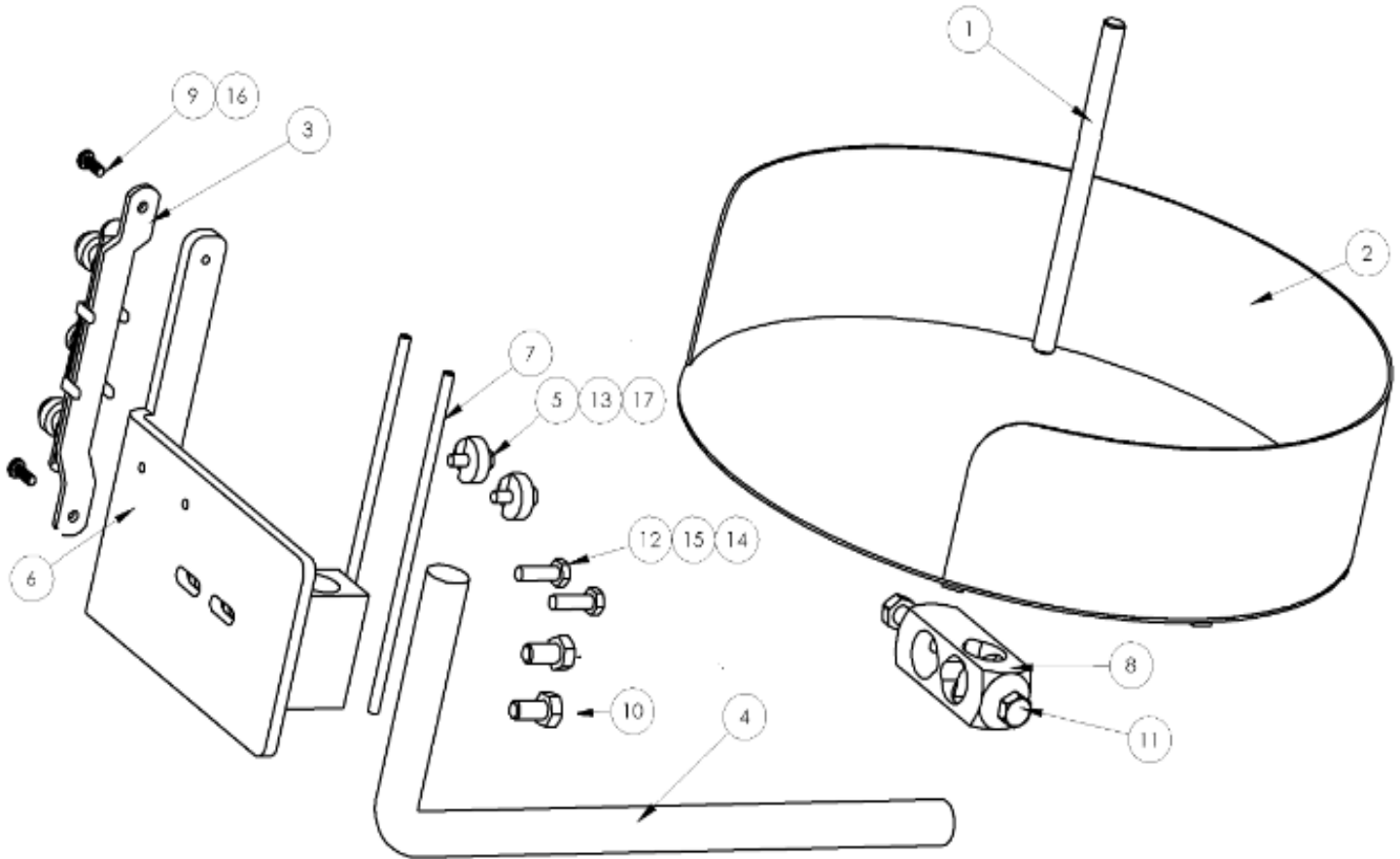

ITEM NO.	QTY.	PART NUMBER	DESCRIPTION	ITEM NO.	QTY.	PART NUMBER	DESCRIPTION
1	1	780-101	ROD, STRAIGHT, CRS	10	2	SSHC10040	5/16-18 X 5/8 HHCS
2	1	785-A9-12B	STATIONARY CRS DISC WITH	11	2	SSHCM8X30	SCREW, HEX CAP M8X30
3	1	1000	TABLE TOP TENSION	12	2	SSHCM6X20S	SCREW, HEX M6X20L SST
4	1	1278-6207B	L-ROD, 3/4	13	2	SSSC98040	10-32 X 5/8 SOC CAP
5	2	1278-7154A	CLAMP, 1/8 TUBE, .75 DIA, .203 ID	14	2	WWFS1/4	WASHER, FLAT, SAE, 1/4
6	1	1345-021	MOUNT, TAPE SPOOL	15	2	WWL1/4	WASHER, LOCK, 1/4
7	2	1345-022	TUBE, THREAD	16	2	WWL8	WASHER, LOCK, #8
8	1	28201	CONNECTOR, ROD, LARGE	17	2	WWL10	WASHER, LOCK, #10
9	2	SSBC90032	8-32X1/2 BUTTON CAP				

# 11345-2CP Tape Edge Workstation

AAC Drawing Number 9009055 Rev 2

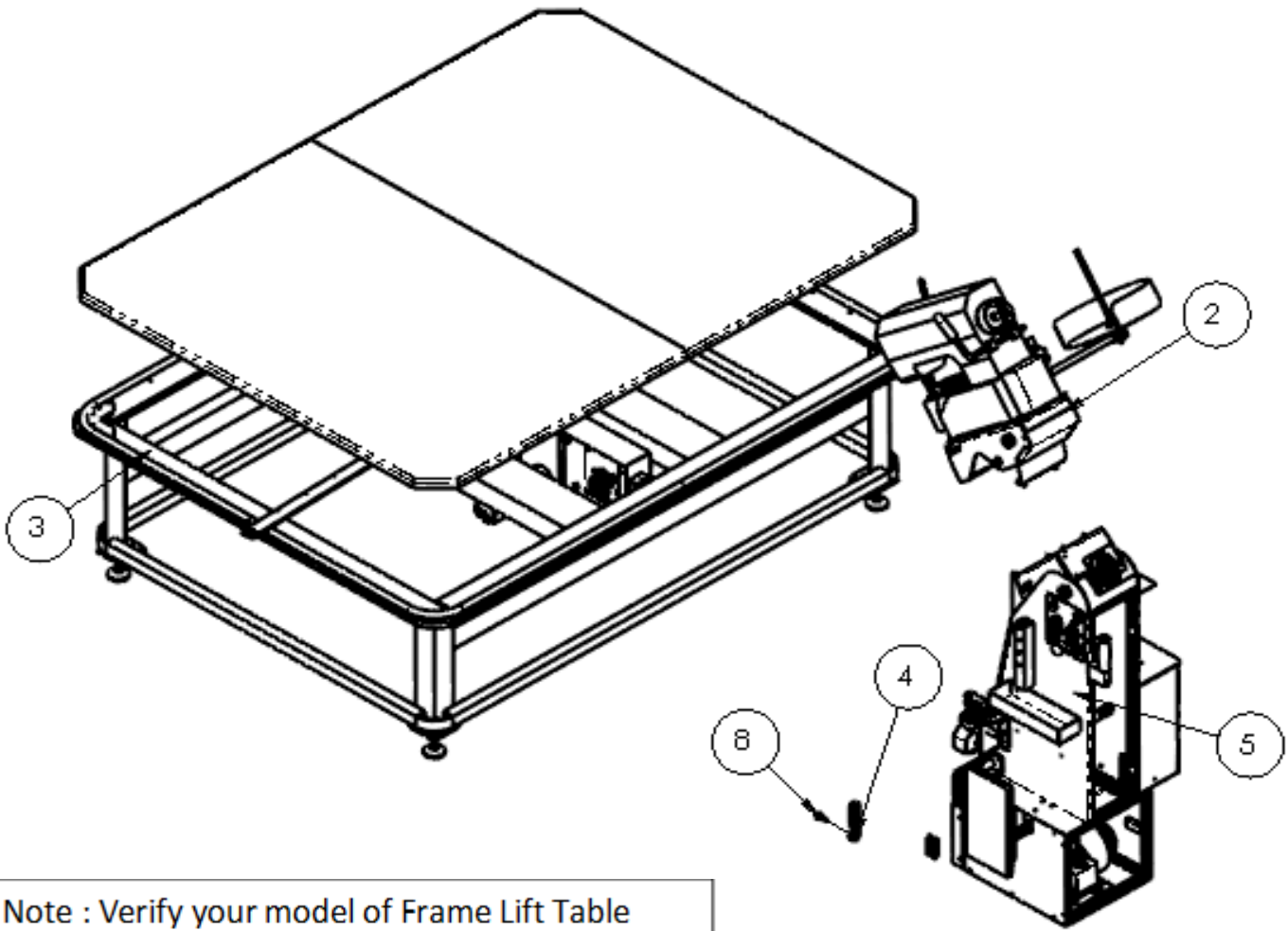

**Note :** Verify your model of Frame Lift Table before ordering parts for table  
 Options: 13451000, 1345485 or 13451000A

ITEM NO.	QTY.	PART NUMBER	DESCRIPTION
1	1	1345-2CWD	WIRING DIAGRAM
2	1	1345170	TOP CARRIAGE ASSY. PFAFF, SPF5625
3	1	13452500A	TABLE ASSY, COMPLETE
4	1	13453428	MOUNT, CAM FOLLOWER
5	1	1345474	CARRIAGE ASSEMBLY
6	1	1345LAB1	LABEL
7	1	1345LAB2	LABEL, TABLE, DON'T SIT/STAND
8	1	MMCCF3/4SB	CAM FOLLOWER, 3/4 DIA
9	3	SSHCO1048GR8	1/4-20 X 3/4 HEX CAP
10	3	WWFS1/4	WASHER, FLAT, SAE, 1/4
11	3	WWL1/4	WASHER, LOCK, 1/4

Service Instructions

**1345170 Sewing Head, Top Carriage Assembly**

AAC Drawing Number 1345170 Rev 1

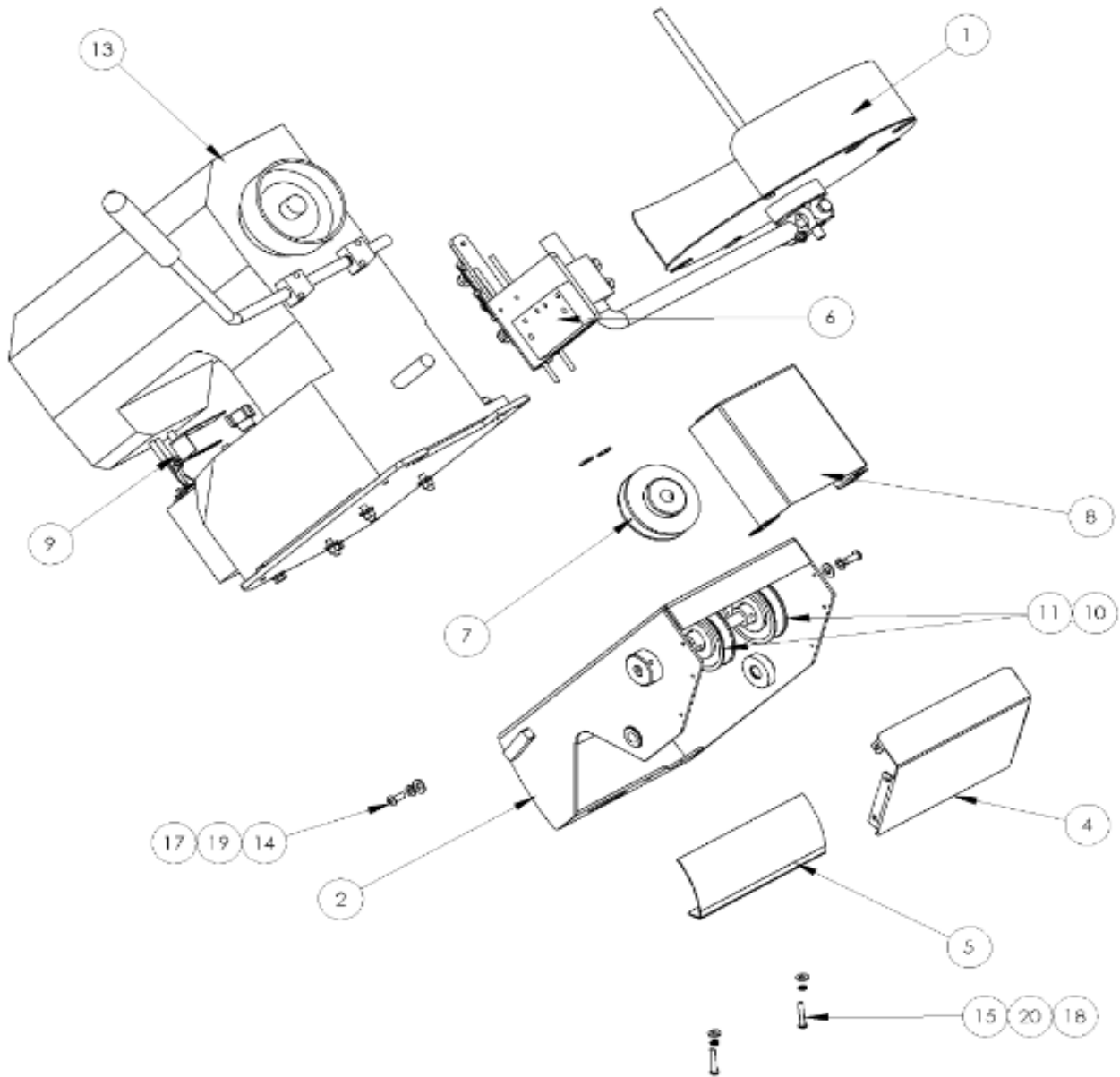

ITEM	QTY	PART NUMBER	DESCRIPTION	ITEM	QTY	PART NUMBER	DESCRIPTION
1	1	1345-025	TAPE ROLL HOLDER ASSY	11	4	MMVA3001	PULLEY
2	1	1345099	MOUNT,SEW HEAD,PIVOTING	12	1	NNE1/4-20	NUT,ELASTIC LOCK,1/4-20
3	1	1345108	SHAFT 60C 1/2 X 8.625 L	13	1	SPF5625-65702M2	HEAD,MOD,GEN,TAPE EDGE
4	1	1345109	COVER,HUB PIVOT	14	2	SSBC01040	1/4-20 X 3/4 BUT CAP SC
5	1	1345112	COVER, CARRIAGE,BACK	15	2	SSBC98072	SCREW,BUTTON CAP
6	1	1345141	PLATE,ADAPTER	16	1	SSSC98032	10-32X1/2, SOC CAP
7	1	1345174	PULLEY,SPAF5625	17	4	WWFS1/4	WASHER,FLAT,SAE,1/4
8	1	1345175	BELT, GUARD, PFAFF 5625	18	3	WWFS10	WASHER, FLAT, #10, SAE
9	1	1345412	TAKE-UP GUARD, PFAFF	19	2	WWL1/4	WASHER,LOCK, 1/4
10	2	13453205	HUB, IDLER PULLEY	20	3	WWL10	WASHER,LOCK,#10

# 11345-2CQSJ Lock Stitch, Queen, Tape Edge Workstation

AAC Drawing Number 90061002 Rev 1

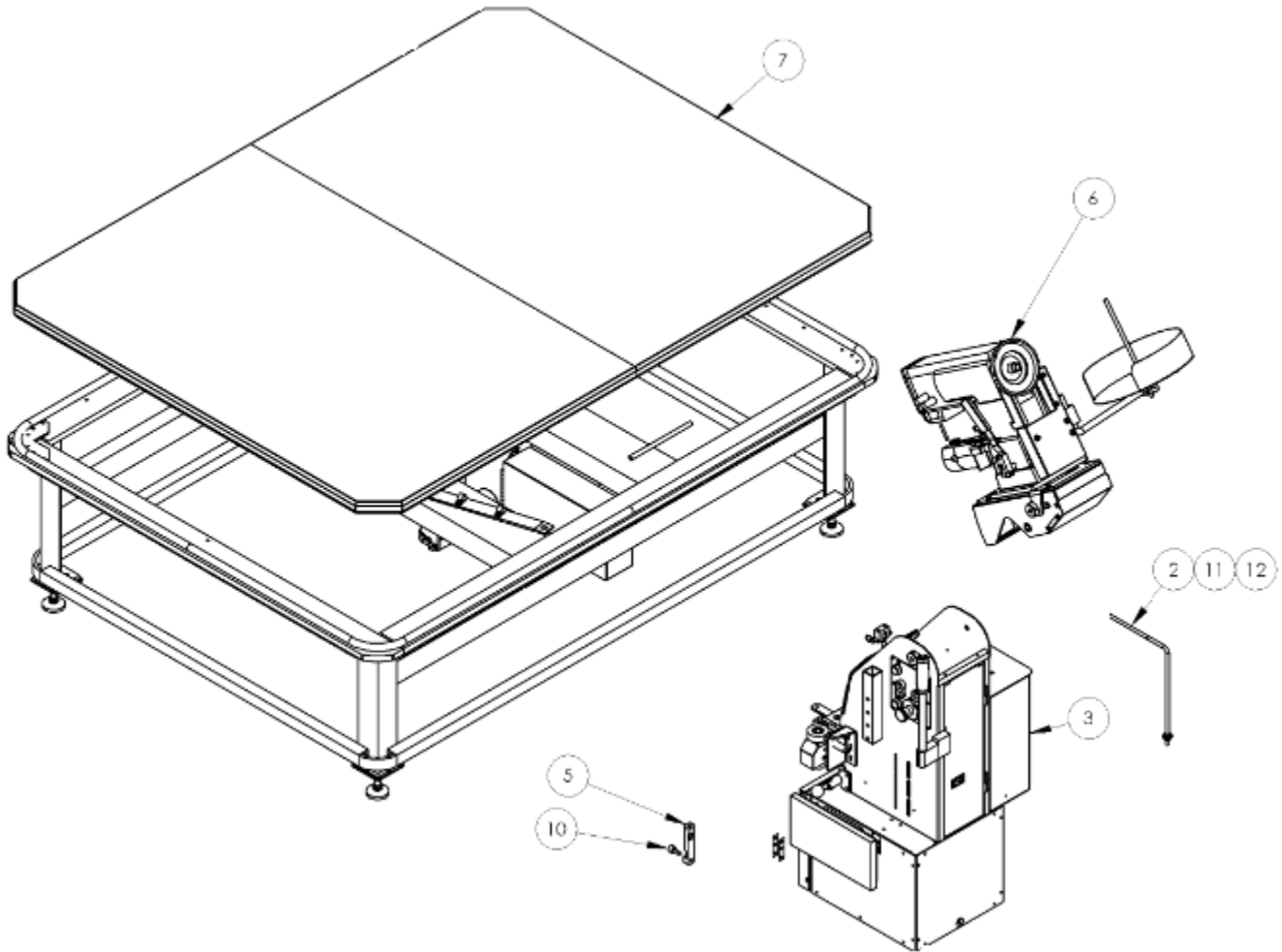

ITEM NO.	QTY.	PART NUMBER	DESCRIPTION
1	1	1345-2CWD	WIRING DIAGRAM
2	1	1345237	THREAD GUIDE ROD
3	1	13453000SA	CARRIAGE ASSEMBLY, SHORT, i510
4	1	13453204	SHAFT 60C 1/2 X 9.10 L
5	1	13453428	MOUNT, CAM FOLLOWER
6	1	1345440	LOCKSTITCH HEAD ASBLY
7	1	13452500A	TABLE ASSY, COMPLETE
8	1	1345LAB1	LABEL
9	1	1345LAB2	LABEL, TABLE, DON'T SIT/STAND
10	1	MMCCF3/4SB	CAM FOLLOWER, 3/4 DIA
11	2	NNH3/8-16	NUT, HEX, 3/8-16
12	2	WWF3/8	WASHER, FLAT, 3/8 OR 10MM

Service Instructions

**1345440 Tape Edge Head, Juki LS1341 Lock stitch**

AAC Drawing Number 1345440 Rev 0

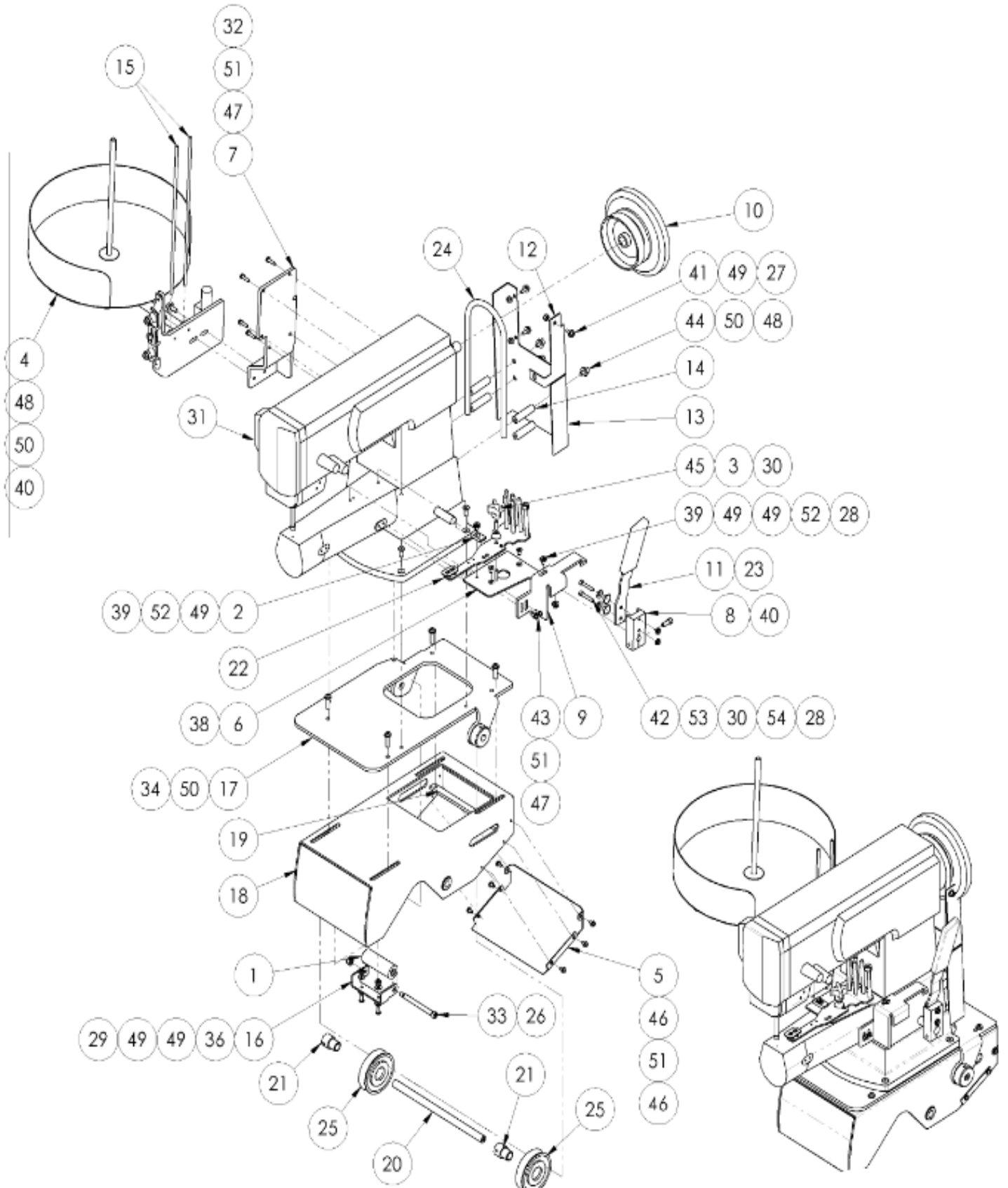

Service Instructions

1345440 parts list

ITEM NO.	QTY.	PART NUMBER	DESCRIPTION	ITEM NO.	QTY.	PART NUMBER	DESCRIPTION
1	1	1278-8301A	PLASTIC IDLER ROLLER	28	3	NNH10-32	HEX-NUT 10-32 REG.
2	1	1345-004	BLOCK, STOP FOR BINDER	29	2	NNK10-32	KEP NUT, 10-32
3	1	1345-009B	SLEEVE,..25 ODX.19 IDX.5LS	30	3	RRBEEHIVEH	SPRING,HEAVY BEEHIVE
4	1	1345-025	TAPE ROLL HOLDER ASSY	31	1	SJUKI-LS1341	SEW HEAD
5	1	1345109	COVER,HUB PIVOT	32	5	SS7111810TP	SCREW,11/64-40X18MM
6	1	1345113	PLATE,BED	33	1	SSAS020192	5/16 X 3,1/4-20 SHLD BOLT
7	1	1345114	BRKT, TAPE HOLDER	34	4	SSBC01064	1/4-20 X 1 BUT CAP SC
8	1	1345115	CLAMP, FOOTLIFT	35	6	SSBC90024	8-32X3/8 BUTTON CAP
9	1	1345116	BRKT, FOOTLIFT LOCKING	36	2	SSBC98032	10-32 X 1/2 BUTTON CAP SC
10	1	1345117	HANDWHEEL,MOD.	37	4	SSFC01040	1/4-20 X 5/8 FLAT ALN CAP
11	1	1345118	HANDLE, FOOTLIFT	38	2	SSFCM5X10	SCREW,FLAT ALLEN CAP
12	1	1345120	BRKT, BELT GUARD	39	2	SSM84-566	SCREW,PAN HD,SLOTTED
13	1	1345121	BRKT,BELT,GUARD,LOWER	40	3	SSSC01040	1/4-20 X 5/8" SOC CAP SC
14	4	1345122	STANDOFF, M6 X 1.75L	41	3	SSSC98032	10-32X1/2, SOC CAP
15	2	1345124	TUBE, THREAD	42	2	SSSC98072	10-32 X 1-1/8 SOC CAP
16	1	1345128	YOKE,ROLLER	43	2	SSSCM4X12	SCREW,SOC CAP,M4-0.7X12
17	1	1345441	PLATE, HEAD MOUNT	44	3	SSSCM6X12	M6X12 SOC CAP SCREW
18	1	1345448	MOUNT,SEW HEAD,PIVOTING	45	1	TTCL1APPK1	PLASTIC KNOB, #10-32
19	2	1345451	NUT PLATE, SEW HEAD SLIDE	46	6	WWF8	WASHER, FLAT, #8
20	1	13453204	SHAFT 60C 1/2 X 9.10 L	47	7	WWFM4.3	WASHER, FLAT, M4
21	2	13453205	HUB, IDLER PULLEY	48	5	WWFS1/4	WASHER,FLAT,SAE,1/4
22	1	F221-T004	SWING OUT MNT,W/ TENSION	49	10	WWFS10	WASHER, FLAT, #10, SAE
23	1	MM9692K36	GRIP,FLAT,3/16X1,SMOOTH	50	9	WWL1/4	WASHER,LOCK, 1/4
24	1	MMGREEN 9010	BELT,URETHANE,10MM OD	51	13	WWL8	WASHER,LOCK,#8
25	2	MMVA3001	PULLEY	52	2	WWL10	WASHER,LOCK,#10
26	1	NNE1/4-20	NUT,ELASTIC LOCK,1/4-20	53	2	WWS307-1	WASHER,SPRING,BELVEL
27	3	NNE10-32	NUT,ELASTIC LOCK	54	2	WWSI10	WASHER,INTERNAL TOOTH,10

# 13453000SA Carriage Assembly, Short, Lock Stitch

AAC Drawing Number 90061001 Rev 0

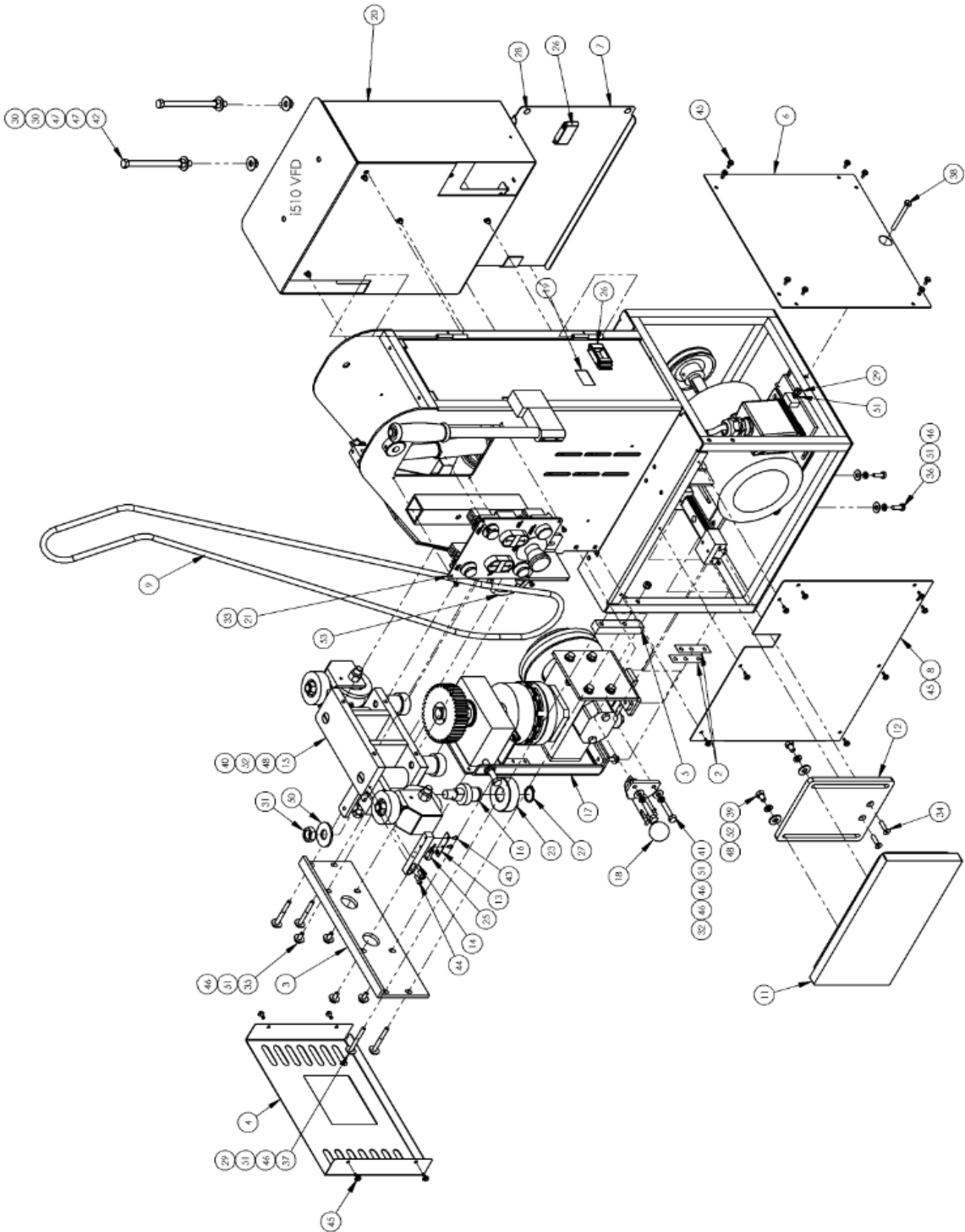

13453000SA parts list

ITEM NO.	QTY.	PART NUMBER	DESCRIPTION	ITEM NO.	QTY.	PART NUMBER	DESCRIPTION
1	*AR	1345-2AWD	WIRING DIAGRAM	28	2	MMSLD-ECH	1/2" DIA RUBBER BUMPER
2	AR	1345049	SHIM. .015 S/S	29	5	NNH1/4-20	NUT,HEX,1/4-20
3	1	1345162	PLATE, MOUNTING, GEARBOX	30	4	NNH3/8-16	NUT,HEX,3/8-16
4	1	1345163	COVER,CARRIAGE,FRONT	31	1	NNH5/8-18	NUT,HEX,5/8-18
5	2	1345168	SPACER, GEARBOX MOUNT	32	2	NNK1/4-20	NUT,KEP,1/4-20
6	1	13453003	COVER,CARRIAGE, REAR	33	4	SSBC90016	8-32 X 1/4 BUTTON CAP
7	1	13453061	DOOR,CARRIAGE, RH	34	2	SSFC01064	1/4-20 X 1 FLAT CAP
8	1	13453062	COVER,CARRIAGE LH	35	4	SSHC01040	1/4-20 X 5/8 HHCS
9	1	13453211B	BELT,DRIVE,10MMX110 IN	36	2	SSHC01048	1/4-20 X 3/4 HEX CAP
10	1	13453300S	TOP CARRIAGE ASSY	37	4	SSHC01144	HEX HEAD, 1/4-20 X 2-1/4
11	1	13453303	KNEE PAD ASSY.	38	1	SSHC01160T	SCREW,HEX CAP
12	1	13453304	BRKT ,MNT, KNEE PAD	39	2	SSHC10032	5/16-18 X 1/2 HHCS
13	1	13453379	HOLDER, PROX SWITCH, BTM	40	4	SSHC10064	5/16-18 X 1 HHCS
14	1	13453380	HOLDER, PROX. SWITCH	41	2	SSHC10096	5/16-18 X 1-1/2 HHCS
15	1	13453400A	CARRIAGE GUIDE ASSY.	42	2	SSHC25352	3/8-16X5-1/2,HEX CAP
16	1	13453420A	BEARING STUD,INNER	43	2	SSPS80016	#6-32 X 1/4 LG PAN HD
17	1	13453500F	GEAR BOX ASSEMBLY	44	2	SSSC98032	10-32X1/2, SOC CAP
18	1	13453800	GEAR LOCK ASSY.	45	20	SSZS93032	SCREW , SHT.METAL 10 ZIP
19	1	1345445	DOOR, CARRIAGE, REAR, SHORT	46	16	WWF1/4	WASHER, FLAT, 1/4", COM
20	1	1345475	CARRIAGE CONTROL BOX ASSY	47	4	WWF3/8	WASHER,FLAT,3/8 OR 10MM
21	1	13459300	CONTROL, BUTTON PANEL	48	5	WWF5/16	WASHER,FLAT,5/16
22	1	13459400	CABLE PACKAGE	49	1	WWF5/16S	WASHER,FLAT,5/16 NARROW
23	1	BB305705C	BEARING,CAM ROLLER	50	1	WWF5/8	WASHER,FLAT,5/8
24	1	FF2226	EDGING,GROMMET	51	15	WWL1/4	WASHER,LOCK, 1/4
25	1	FFUZP111	PROX SENSOR, SUNX	52	6	WWL5/16	WASHER,LOCK, 5/16
26	2	MM40450010	FASTENER,SLIDE LOCK	53	1	ZX3824	V-BELT, 3/8 X 24"
27	1	MMSH-98	RING,SNAP,EXTERNAL				

# Service Instructions

## 13453500F Gear Box Assembly

AAC Drawing Number 9007118 Rev0

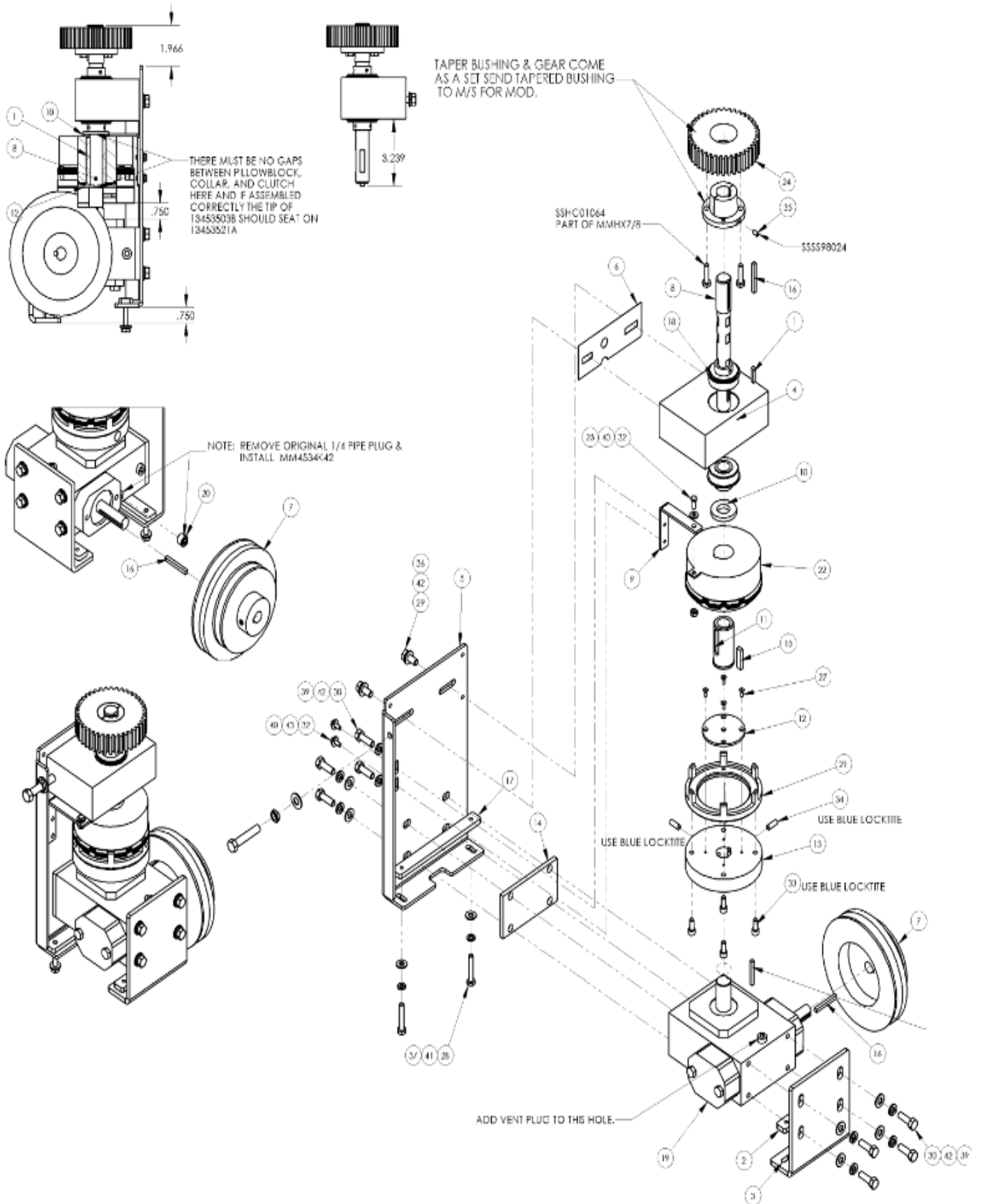

## 13453500F parts list

ITEM NO.	Default/QTY.	PART NUMBER	DESCRIPTION
1	1	132556-258	KEY, 3/16 X .813 L
2	1	1345041	NUT PLATE,1/4-20X3.25
3	1	1345167	BRKT, GEAR BOX, LOWER
4	1	1345176	BLOCK, BEARING MOUNTING
5	1	1345178	PLATE,GEAR BOX
6	AR	1345359	SHIM, BEARING MOUNTING
7	1	13453521	PULLEY,DRIVE
8	1	13453503B	SHAFT, GEAR DRIVE
9	1	13453512A	BRKT, ANTI ROTATE, CLUTCH
10	1	13453514	SPACER, CLUTCH
11	1	13453516	SLEEVE, CLUTCH
12	1	13453519A	PLATE,CLUTCH, LOWER
13	1	13453501	PLATE, CLUTCH ADAPTER
14	1	13453522	SPACER, GEAR BOX
15	1	13453523	KEY,5MM X8MM X 1 1/4
16	2	13453524	KEY,3/16 X 1.68L
17	1	13453532	NUT PLATE,1/4-20X5.75
18	2	BBS8703-88	BEARING,BALL,.75IDX1.75OD
19	1	MM20UM1	GEAR BOX, MOD.
20	1	MM4534K42	PLUG, FLUSH, 1/4" PIPE
21	1	MM231572	COUPLING
22	1	MM231631M1	CLUTCH, MOD, 1345
24	1	MMS1040	GEAR, 40T, 10P
25	1	NNE10-32	NUT,ELASTIC LOCK
26	1	NNJ3/8-24	3/8-24 JAM NUT
27	4	SSFC80024	6-32 X 3/8 FLAT CAP
28	2	SSHHC01096	1/4-20 X 1-1/2 HHCS
29	2	SSHHC10048	5/16-18 X 3/4 HHCS
30	8	SSHHC10064	5/16-18 X 1 HHCS
31	1	SSHHC35128F	3/8-24 X 2.0 FULL THD
32	3	SSHHC98032	10-32X1/2 HEX HD
33	4	SSSCM6X15	M6X15 SOC CAP SCREW
34	2	SSSS01048	1/4-20 X 3/4
35	AR	SSSS98024	10-32X 3/8 SOC SET SC
36	2	WWF5/16S	WASHER,FLAT,5/16 NARROW
37	2	WWFS1/4	WASHER,FLAT,SAE,1/4
38	1	WWFS3/8	WASHER,FLAT,SAE,3/8
39	8	WWFS5/16	WASHER,FLAT,SAE,5/16
40	3	WWFS10	WASHER, FLAT, #10, SAE
41	2	WWL1/4	WASHER,LOCK, 1/4
42	10	WWL5/16	WASHER,LOCK, 5/16
43	2	WWL10	WASHER,LOCK,#10

**13453300S Top Carriage Assembly**

AAC Drawing Number 9006801 Rev 0

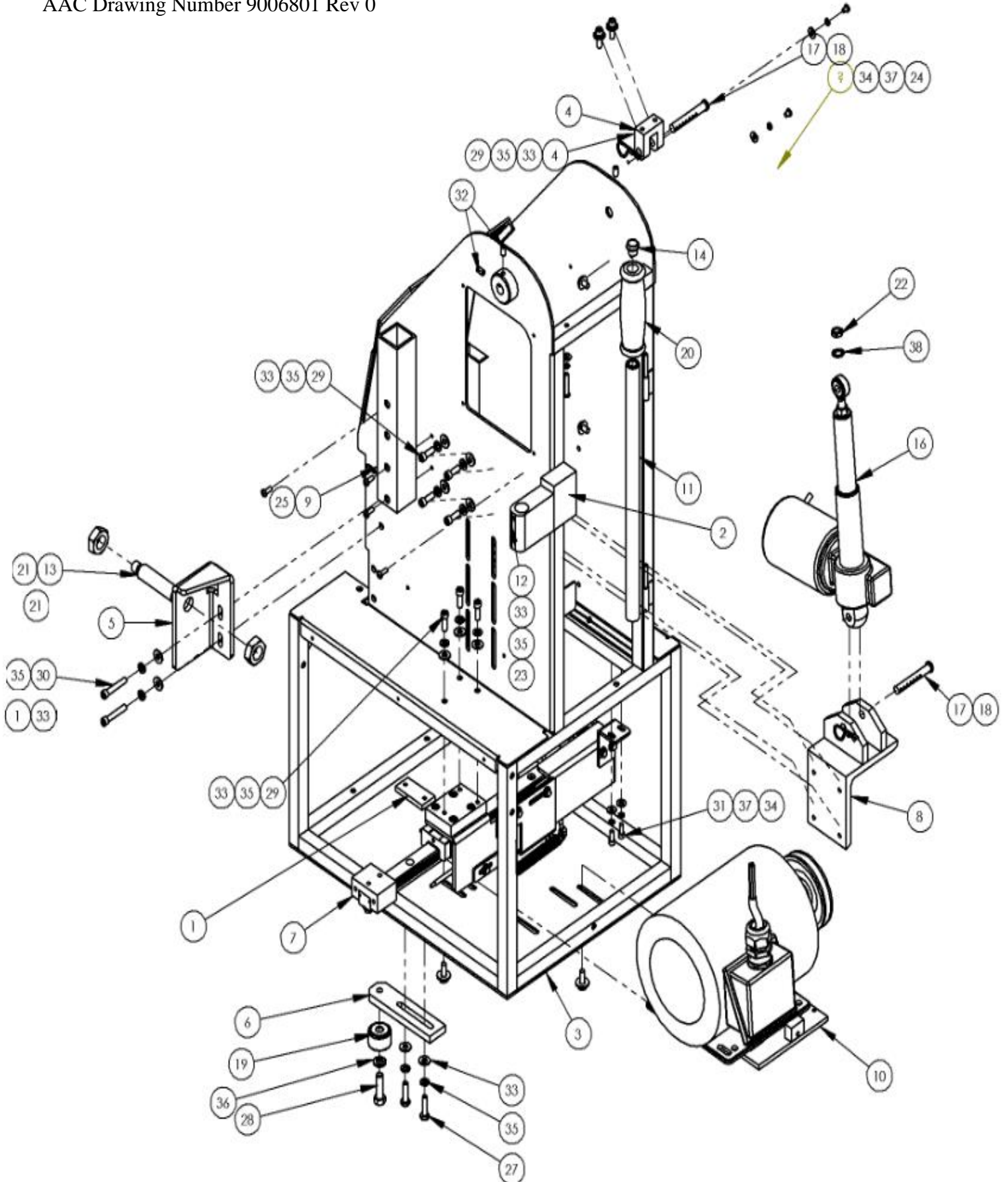

## 13453300S parts list

ITEM NO.	Hardware Shown/QTY.	PART NUMBER	DESCRIPTION
1	2	029-003A	PLATE, NUT, 1/4-20 @ 1.50
2	1	1345238	HANDLE MOUNT ADAPTOR
3	1	13453100S	CARRIAGE, FRAME ASSY,
4	1	13453202	CLEVIS, ACTUATOR
5	1	13453301	MOUNT, SHOCK ABSORBER
6	1	13453313	MOUNT, CARRIAGE GUIDE, LO
7	1	13453370	KNEE SWITCH ASSY.
8	1	13453378	WELDMENT,PIVOT SUPPORT
9	1	13453385	HOLDER, SCISSOR
10	1	13453390A	MOTOR ASSEMBLY
11	1	33005110B	HANDLE 14L
12	1	33005116	SPACER, HANDLE MOUNT
13	1	AAOEM.5BSAL	SHOCK, 3/4-18 X 3.5
14	1	EE49111AS	PUSH BUTTON SWITCH ASSY
15	1	MM9307K69	GROMMET,5/8,1.125,.125GV
16	1	MM85151-2M1	ACTUATOR, MOD
17	2	MM98330A245	CLEVIS PIN 2.25LG STL
18	2	MM98335A064	SPRING CLIP
19	1	MMCYR114S	FOLLOWER, CAM
20	1	MMGP-105	GRIP HANDLE-FOAM 3/4 ID
21	2	NNJ3/4-16	3/4-10 JAM NUT
22	1	NNJ3/8-24	3/8-24 JAM NUT
23	2	SSBC01032	1/4-20 X 1/2 BUT CAP SC
24	2	SSBC98016	10-32 X 1/4 BUTTON CAP SC
25	4	SSBC98032	10-32 X 1/2 BUTTON CAP SC
26	2	SSBC98072	SCREW ,BUTTON CAP
27	2	SSH001064	1/4-20 X 1 HHCS
28	1	SSH025080	3/8-16X1-1/4 HHCS
29	9	SSSC01048	1/4-20 X 3/4" SOC CAP SC
30	2	SSSC01096	1/4-20 X 1-1/2 SOC CAP
31	2	SSSC98032	10-32X1/2, SOC CAP
32	4	SSSS01032	SCREW , SET, 1/4-20 X 1/2
33	15	WWFS1/4	WASHER,FLAT,SAE,1/4
34	6	WWFS10	WASHER, FLAT, #10, SAE
35	15	WWL1/4	WASHER,LOCK, 1/4
36	1	WWL3/8	WASHER,LOCK, 3/8
37	6	WWL10	WASHER,LOCK,#10
38	1	WWSI3/8	WASHER,INTERNAL TOOTH,3/8

Service Instructions

**13459300 Control Button Panel**

AAC Drawing Number 9001107 Rev 2

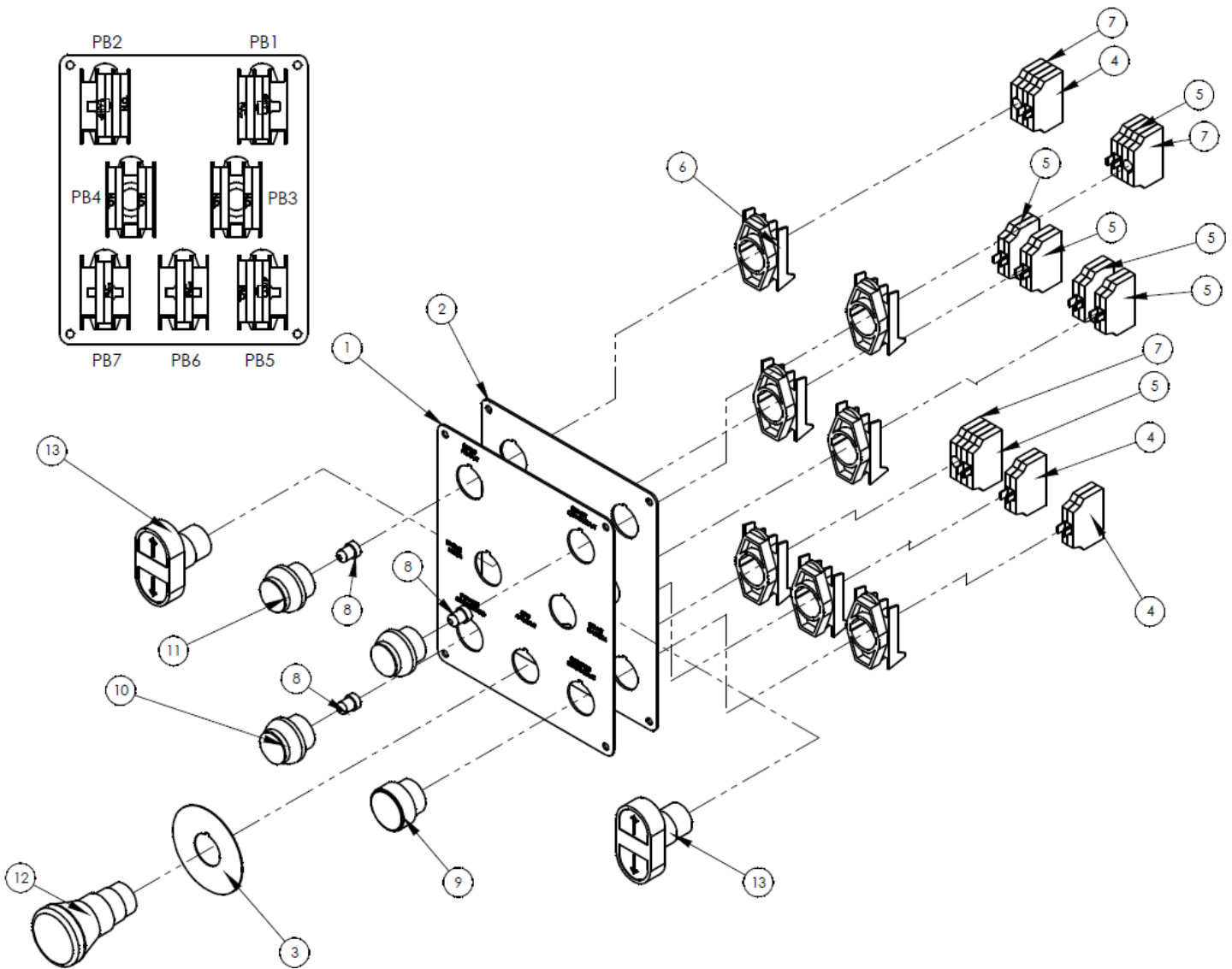

NO.	QTY	PART #	DESCRIPTION	NO.	QTY	PART #	DESCRIPTION
1	1	13452LAB	LABEL,SWITCH PANEL	9	1	EEPFA6	BUTTON, PUSH, BLU, FLUSH
2	1	13459301	PANEL, SWITCH	10	2	EEPLE3	BUTTON, PUSH, GRN, ILLUM
3	1	EE15Y	PLATE, LEGEND, YELLOW	11	1	EEPLE4	BUTTON, PUSH, RED, ILLUM
4	3	EE3X01	BLOCK,P.B. CONTACT, N.C.	12	1	EEPMTS44	E-STOP BUTTON, TWIST REL.
5	6	EE3X10	BLOCK,P.B. CONTACT, N.O.	13	2	EEPU2A3	BUTTON, PUSH 22MM, 2X,G MOM FLUSH
6	7	EEA3L	LATCH,PUSH BUTTON	14	6'	FF18988C	CABLE, 8 COND, 18GA
7	3	EED53D0	BLOCK, LAMP, 22MM P.B.	15	18'	FF19511	CABLE, 3 COND, 14GA
8	3	EED5N157	LAMP, INCONDECENT, BAYONET				

# 11345-2CTSJ Lock Stitch, Twin. Tape Edge Workstation

AAC Drawing Number Rev 1

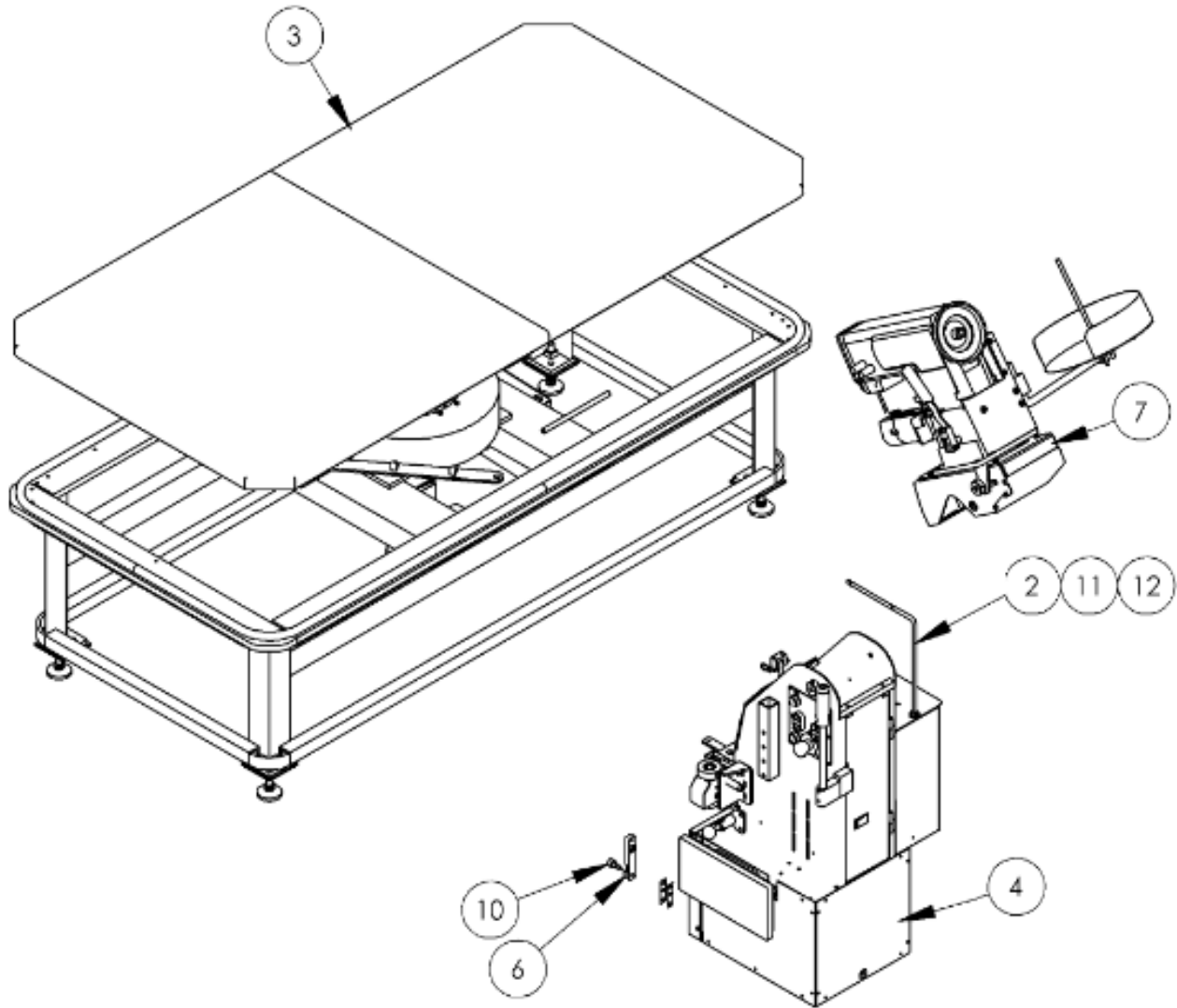

ITEM NO.	QTY.	PART NUMBER	DESCRIPTION
1	1	1345-2CWD	WIRING DIAGRAM
2	1	1345237	THREAD GUIDE ROD
3	1	13452500TA	FRAME & TABLE, TWIN
4	1	13453000SA	CARRIAGE ASSEMBLY, SHORT, i510
5	1	13453204	SHAFT 60C 1/2 X 9.10 L
6	1	13453428	MOUNT, CAM FOLLOWER
7	1	1345440	LOCKSTITCH HEAD ASBLY
8	1	1345LAB1	LABEL
9	1	1345LAB2	LABEL, TABLE, DON'T SIT/STAND
10	1	MMCCF3/4SB	CAM FOLLOWER, 3/4 DIA
11	2	NNH3/8-16	NUT, HEX, 3/8-16
12	2	WWF3/8	WASHER, FLAT, 3/8 OR 10MM

Service Instructions

**13452500TA Frame Lift Table, Twin,**

AAC Drawing Number 9009185 Rev 0

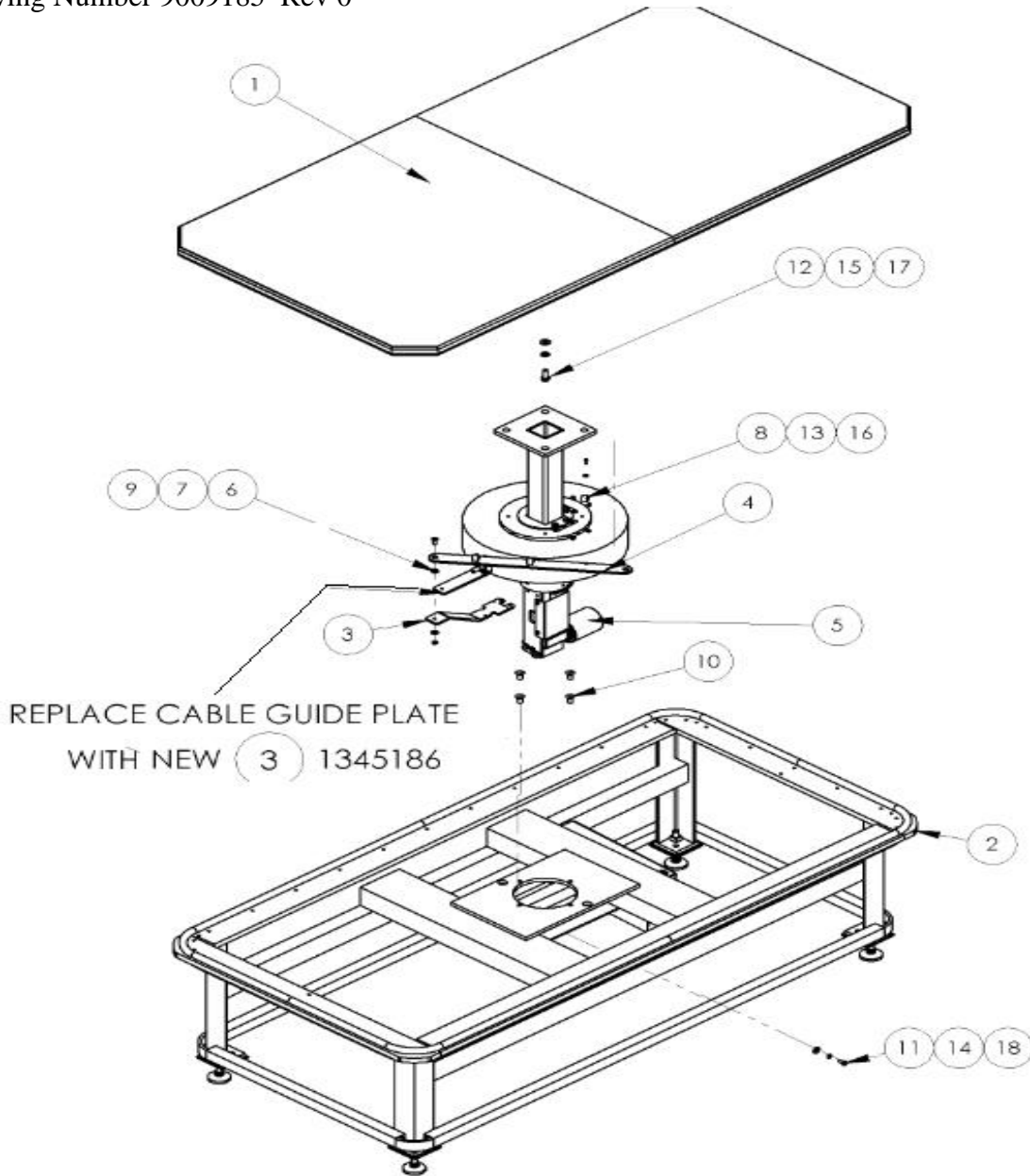

ITEM	QTY.	PART NUMBER	DESCRIPTION	ITEM	QTY.	PART NUMBER	DESCRIPTION
1	1	1345091	TABLE TOP FRAME ASSY, TWI	10	4	SSFC45064	1/2-13 X 1 SOC FLAT CAP
2	1	13451000TA	BASE ASSY LIFT TABLE,TWIN	11	2	SSHC10048	5/16-18 X 3/4 HHCS
3	1	1345186	PLATE, CABLE GUIDE, TWIN	12	4	SSHC45080	1/2-13X1-1/4 HEX CAP
4	1	1345187	LINK, CABLE ASSY,TWIN	13	3	SSSC98032	10-32X1/2, SOC CAP
5	1	13452000D	COLUMN, LIFT ASSY	14	2	WWF5/16	WASHER,FLAT,5/16
6	2	BBTRA613	WASHER,THRUST,STL, .375B	15	4	WWFS1/2	WASHER,FLAT,1/2, SAE
7	1	NNJ5/16-18	NUT,JAM,5/16-18	16	3	WWFS10	WASHER, FLAT, #10, SAE
8	3	PPP2217	WIRE CLAMP, .337I.D.	17	4	WWL1/2	1/2 LOCK WASHER
9	1	SSFC10056S	10-32 x 2 FLAT ALLEN	18	2	WWL5/16	WASHER,LOCK, 5/16

Service Instructions

**13451000TA Base Lift Table, Twin**

AAC Drawing Number 9009184 Rev 0

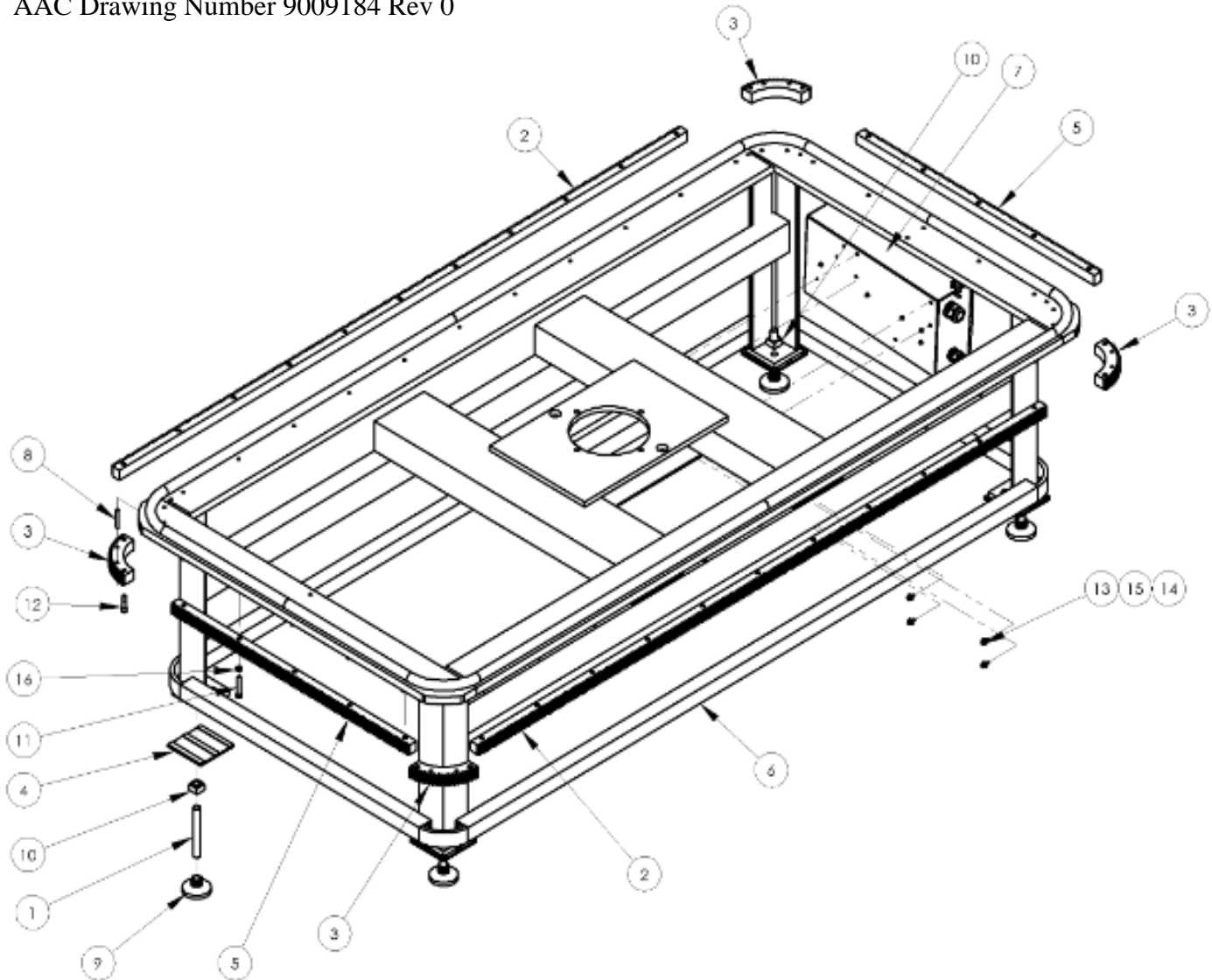

ITEM	QTY.	PART NUMBER	DESCRIPTION	ITEM	QTY.	PART NUMBER	DESCRIPTION
1	4	0411-1063	ROD, THREADED, 5/8-11 X 5	9	4	MML-2	LEVELING PAD, 5/8-11
2	2	13451020	GEAR RACK, LONG	10	8	NNSH5/8-11	NUT, SQUARE, 5/8-11
3	4	13451021	GEAR RACK, CORNER, 10 DP, 84 TEETH, 1" THK	11	32	SSHC10112	SCREW, HEX, 5/16-18X1-3/4
4	(*)	13451029	PAD, RUBBER	12	8	SSSC10080	5/16-18 X 1-1/4 SOC CAP
5	2	1345179	GEAR RACK, TWIN	13	4	SSSC98032	10-32X1/2, SOC CAP
6	1	1345182	FRAME, WELDMENT, TWIN	14	4	WWFS10	WASHER, FLAT, #10, SAE
7	1	1345495	CONTROL BOX, HIGH VOLTAGE	15	4	WWL10	WASHER, LOCK, #10
8	8	IIS016X112	ROLL PIN 1/8 DIA X 1 1/2 SS	16	32	WWL5/16	WASHER, LOCK, 5/16

## **Obsolete, Revisions or Replacement Assemblies.**

Special Note: please verify your Model of Frame Lift Table, before ordering parts.

Version 1 see 13452500A Revision 11 for table model 1345100

Version 2 see 1345485 Revision 11 for table model 1345485

Version 3 see 13452500A Revision 12 for table model 13451000A as of March 2022

# 13452500A Frame Lift Tablet - Revision 11

AAC Drawing Number 9001366 Rev 11

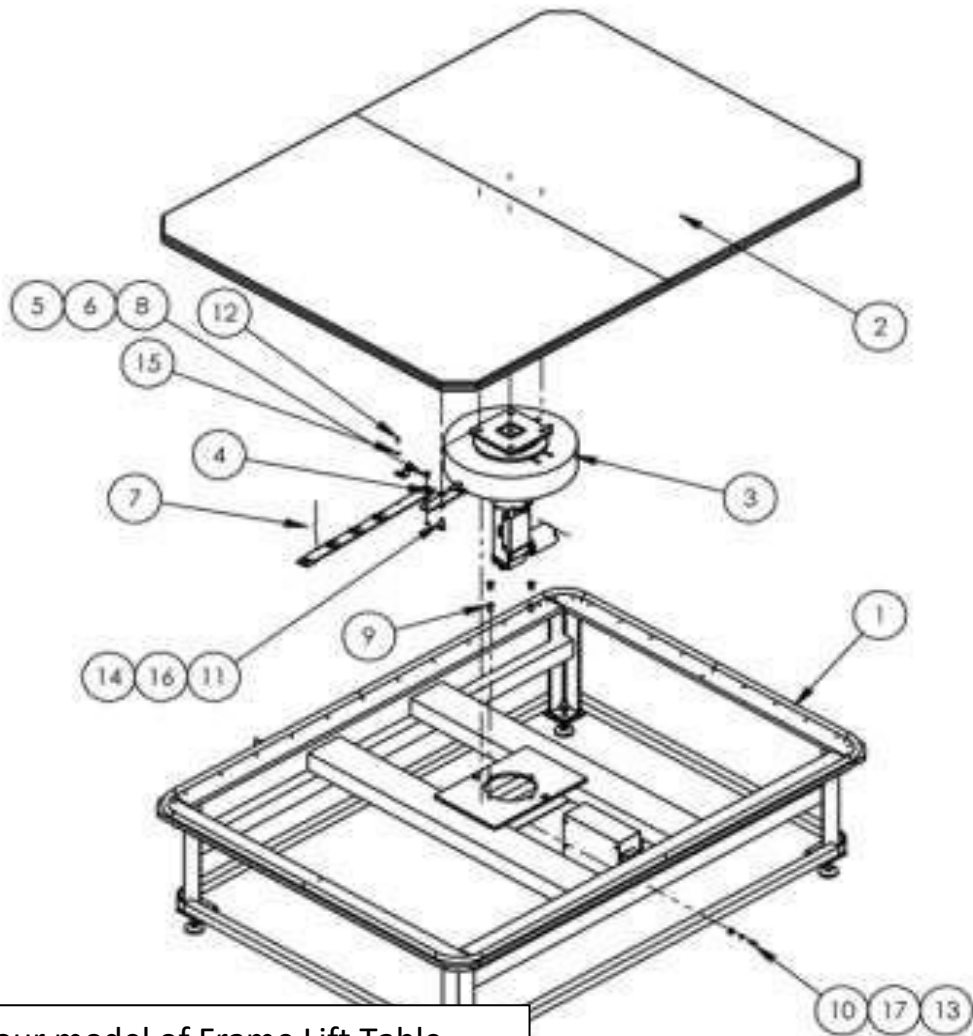

Note : Verify your model of Frame Lift Table before ordering parts for table  
 Options: 13451000, 1345485 or 13451000A

NO.	QTY	PART #	DESCRIPTION	NO.	QTY	PART #	DESCRIPTION
1	1	13451000	BASE ASSY LIFT TABLE TAPE	10	2	SSHC10048	5/16-18 X 3/4 HHCS
2	1	13451200	TABLE TOP ASSY,QUEEN	11	4	SSHC45080	1/2-13X1-1/4 HEX CAP
3	1	13452000D	COLUMN, LIFT ASSY	12	4	SSSC98032	10-32X1/2, SOC CAP
4	1	13452027	LINK, CABLE ASSY,TWIN	13	2	WWF5/16	WASHER,FLAT,5/16
5	2	BBTRA613	WASHER,THRUST,STL, .375B	14	4	WWFS1/2	WASHER,FLAT,SAE,1/2
6	1	NNJ5/16-18	NUT,JAM,5/16-18	15	4	WWFS10	WASHER, FLAT, #10, SAE
7	4	PPP2217	WIRE CLAMP, .337I.D.	16	4	WWL1/2	1/2 LOCK WASHER
8	1	SSFC10056S	10-32 x 2 FLAT ALLEN	17	2	WWL5/16	WASHER, LOCK, 5/16
9	4	SSFC45064	1/2-13 X 1 SOC FLAT CAP				

**13451000 Lift Table Base Assembly**

AAC Drawing Number 9001365 Rev 7

**OBSOLETE REPLACED BY  
13451000A - March 2022**

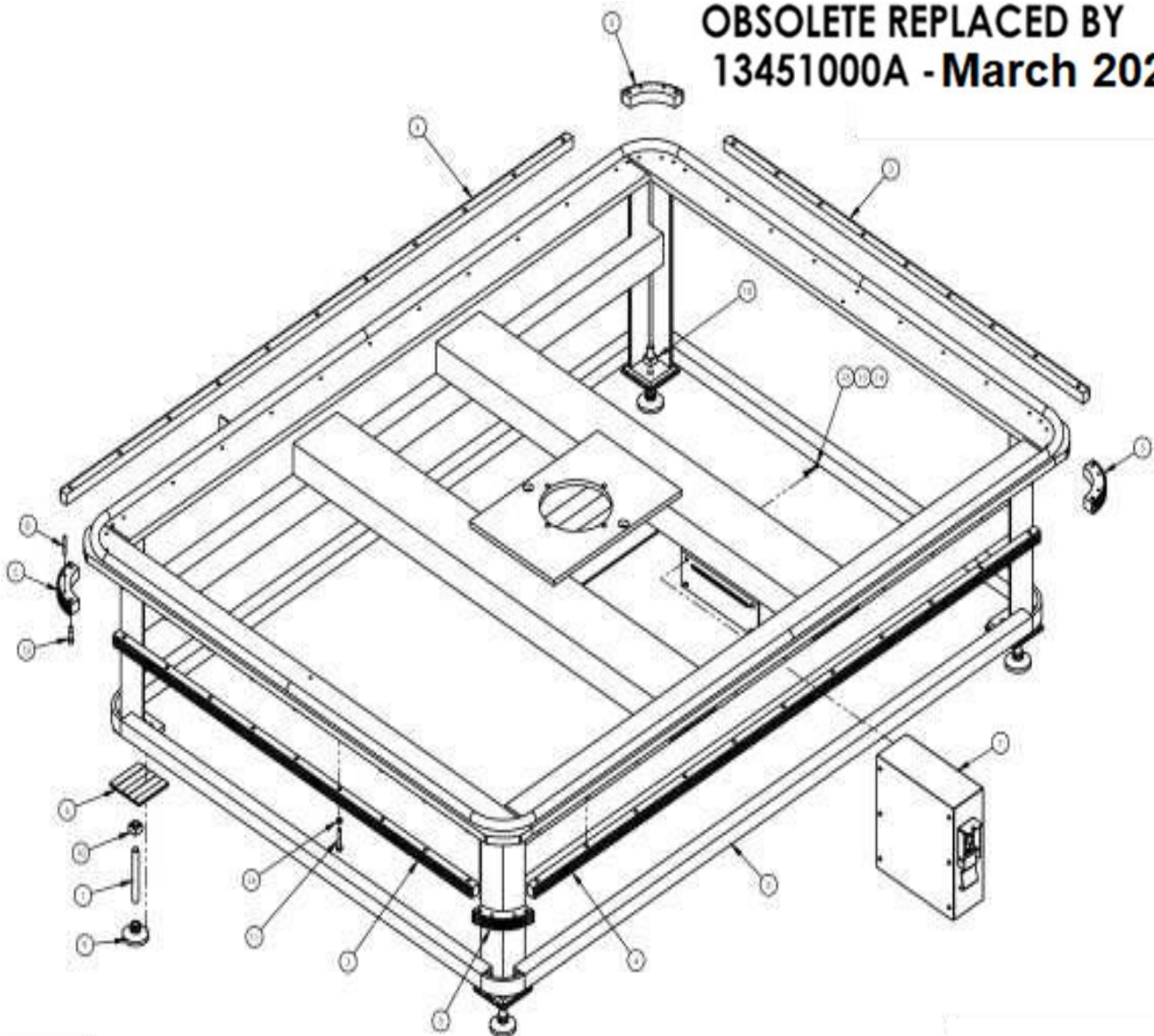

ITEM	QTY.	PART NUMBER	DESCRIPTION	ITEM	QTY.	PART NUMBER	DESCRIPTION
1	4	0411-1063	ROD, THREADED, 5/8-11 X 5	9	4	MML-2	LEVELING PAD, 5/8-11
2	1	1345027	FRAME, WELDMENT	10	8	NNSH5/8-11	NUT, SQUARE, 5/8-11
3	2	13451019	GEAR RACK, SHORT	11	40	SSHC10112	SCREW, HEX, 5/16-18X1-3/4
4	2	13451020	GEAR RACK, LONG	12	4	SSHC98032	10-32X1/2 HEX HD
5	4	13451021	GEAR RACK, CORNER	13	8	SSSC10080	5/16-18 X 1-1/4 SOC CAP
6	4	13451029	PAD, RUBBER	14	4	WWFS10	WASHER, FLAT, #10
7	1	13459500	CONTROL BOX	15	4	WWL10	WASHER, LOCK, #10
8	8	IIS016X112	ROLL PIN 1/8 DIA X 1 1/2 SS	16	40	WWL5/16	WASHER, LOCK, 5/16

Service Instructions

**13459500 Control Box**

AAC Drawing Number 9001947 Rev 1

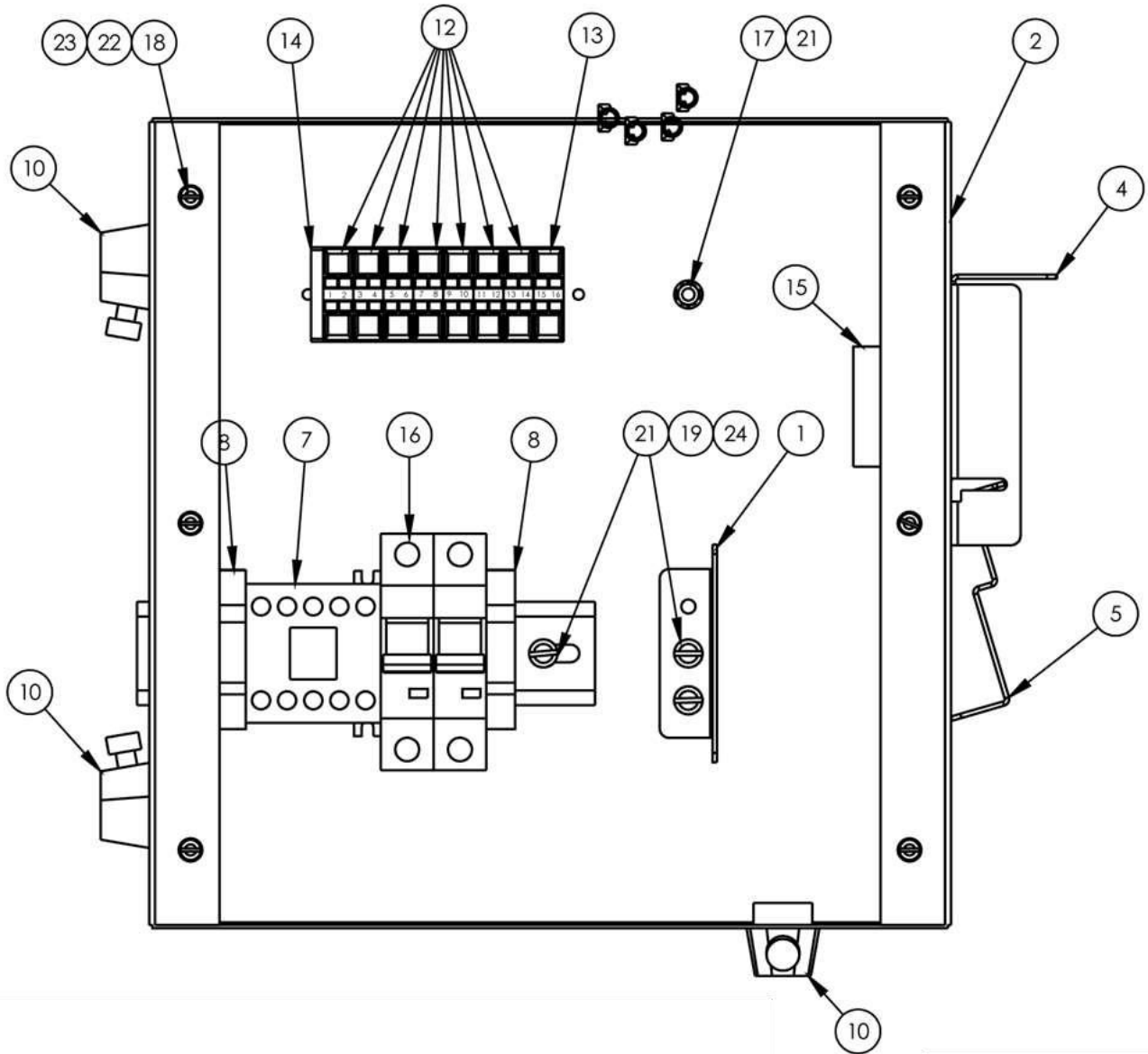

NO.	QTY	PART #	DESCRIPTION	NO.	QTY	PART #	DESCRIPTION
1	1	13459004A	MOUNTING BRACKET, CAPACITOR	13	1	FF264-347	TERMBLK,WAGO,TOP,DUAL,GRN
2	1	13459501	PANEL,HIGH VOLTAGE	14	1	FF264-371	TERMBLK,WAGO,TOP,END
3	1	13459503	COVER, ELECTRICAL PANEL	15	1	FF3120L420A	CIRCUIT BREAKER, THERMAL
4	1	40-322	BOTTOM, AC POWER LOCKOUT	16	1	FFL722C	BREAKER, CIRCT. THERM-MAG
5	1	40-323	TOP, AC POWER LOCKOUT	17	1	NNK8-32	NUT,KEP,8-32
6	2	EEAK42BS	RIVET,BLIND 1/8 DIA ALUM.	18	6	SSPS80016	#6-32 X 1/4 LG PAN HD
7	1	EECA491024	CONTACTOR, MINI, 240V	19	4	SSPS98024	10-32X3/8 PAN HD SLOT
8	2	EECLIPFIX	ANCHOR,DIN RAIL	20	4	TTBB5263	TERMINAL,.25 FULLY INSUL
9	1	EETS35X7.5A	DIN RAIL-EURO	21	5	WWF8	WASHER, FLAT, #8
10	4	FF1724	STRAIN RELIEF	22	6	WWFS6	WASHER, FLAT, #6
11	15	FF19511	CABLE, 3 COND, 14GA	23	6	WWL6	WASHER,LOCK,#6
12	7	FF264-341	TERMBLK,WAGO,TOP,DUAL,GRY	24	4	WWL8	WASHER,LOCK,#8

# Service Instructions

## 1345-2AWD Wiring Diagram

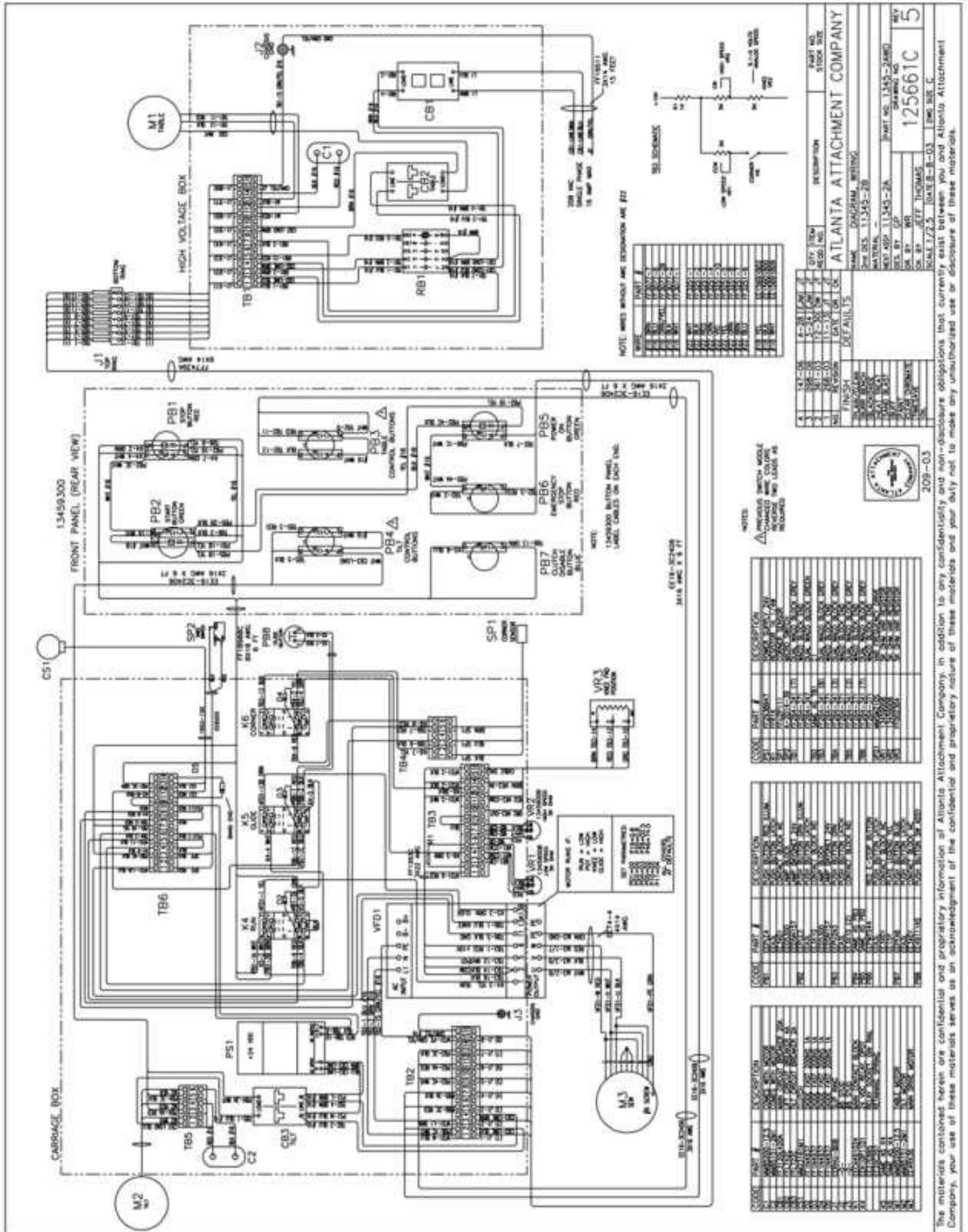

# 1345485 Frame Lift Table - Revision 11

AAC Drawing Number 1345485 Rev 11

**OBSOLETE REPLACED BY  
13452500A - March 2022**

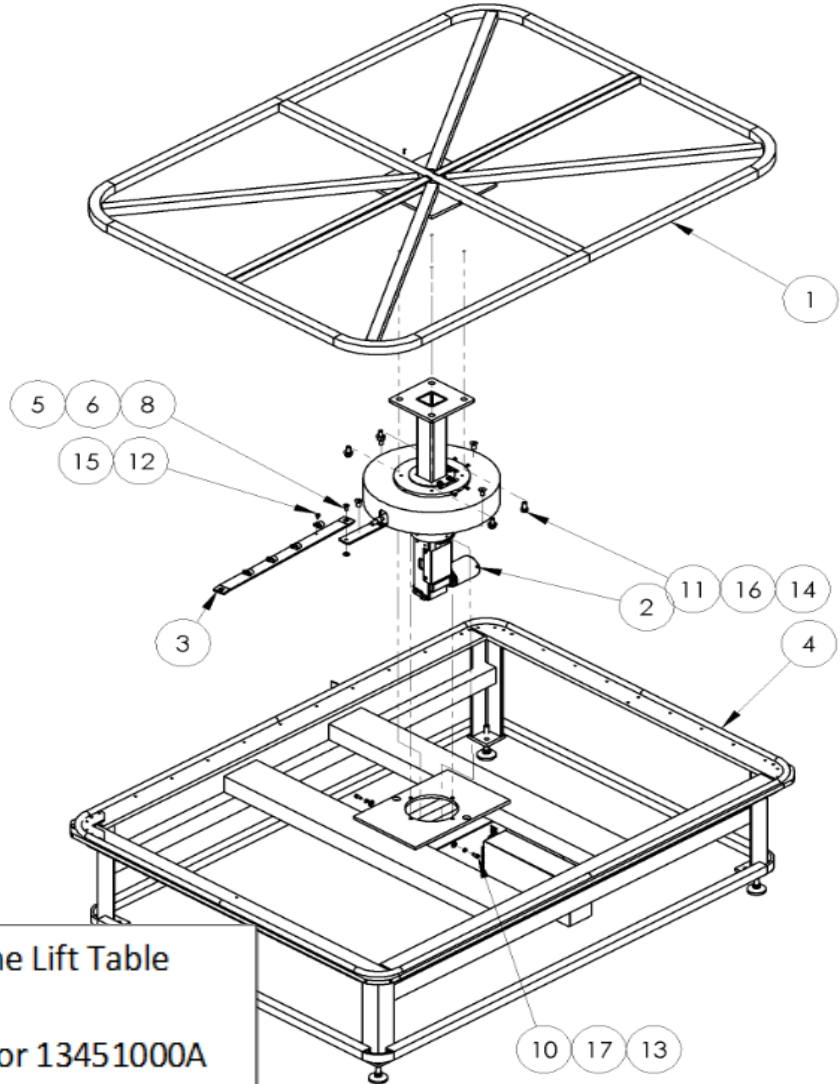

**Note :** Verify your model of Frame Lift Table before ordering parts for table  
Options: 13451000, 1345485 or 13451000A

ITEM	QTY	PART NUMBER	DESCRIPTION	ITEM	QTY	PART NUMBER	DESCRIPTION
1	1	13451200	TABLE TOP ASSY,QUEEN	10	2	SSHHC10048	5/16-18 X 3/4 HHCS
2	1	13452000D	COLUMN, LIFT ASSY	11	4	SSHHC45080	1/2-13X1-1/4 HEX CAP
3	1	13452027	LINK, CABLE ASSY,TWIN	12	4	SSSC98032	10-32X1/2, SOC CAP
4	1	1345490	BASE ASSY LIFT TABLE TAPE,	13	2	WWF5/16	WASHER,FLAT,5/16
5	2	BBTRA613	WASHER,THRUST,STL, .375B	14	4	WWFS1/2	WASHER,FLAT,1/2, SAE
6	1	NNJ5/16-18	NUT,JAM,5/16-18	15	4	WWFS10	WASHER, FLAT, #10, SAE
7	4	PPP2217	WIRE CLAMP, .337I.D.	16	4	WWL1/2	1/2 LOCK WASHER
8	1	SSFC10056S	10-32 x 2 FLAT ALLEN	17	2	WWL5/16	WASHER,LOCK, 5/16
9	4	SSFC45064	1/2-13 X 1 SOC FLAT CAP				

**1345490 Base, Lift Table**

AAC Drawing Number 1345490 Rev 1

**OBSOLETE REPLACED BY  
13451000A - March 2022**

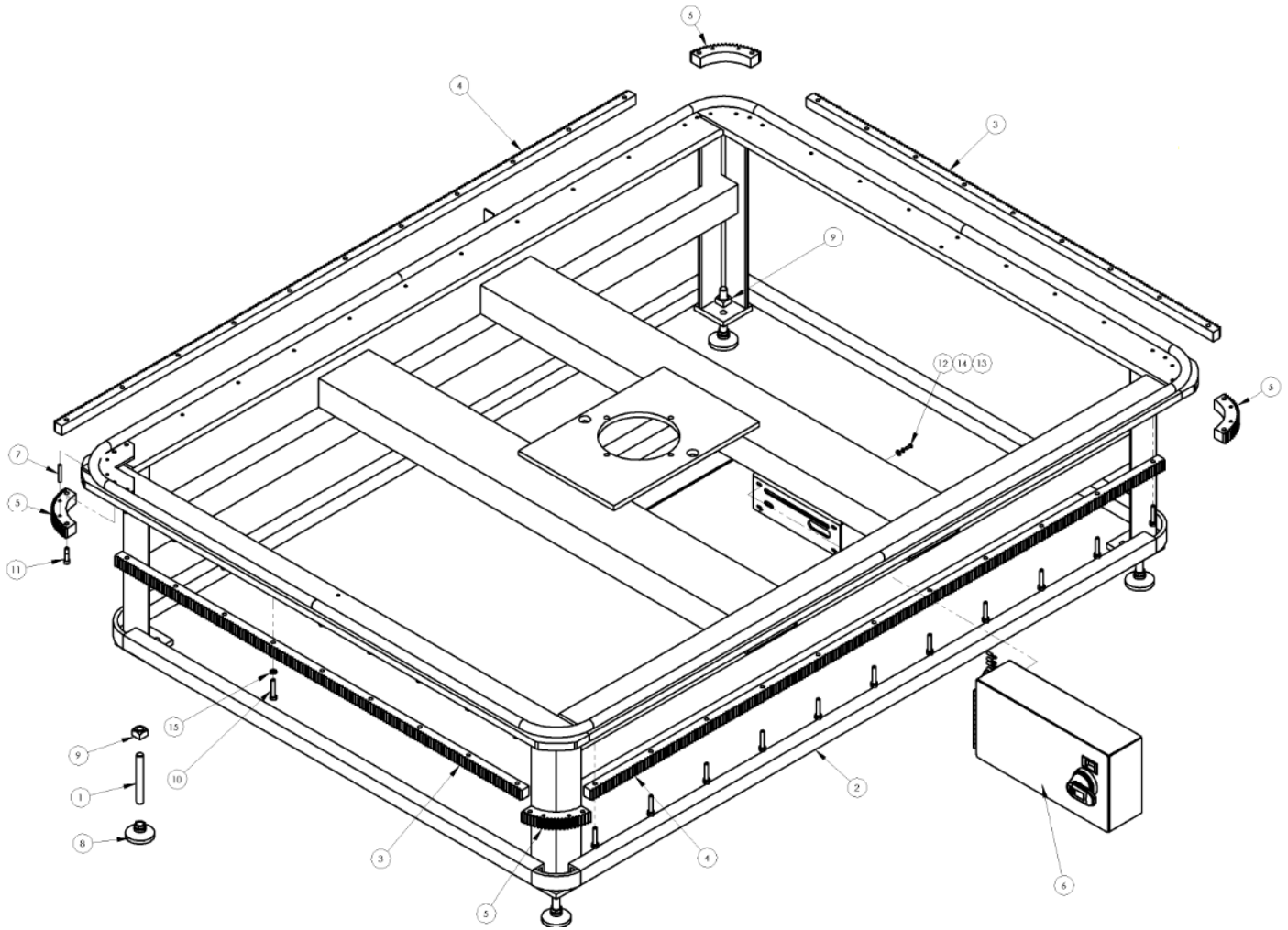

ITEM	QTY	PART NUMBER	DESCRIPTION	ITEM	QTY	PART NUMBER	DESCRIPTION
1	4	0411-1063	ROD, THREADED, 5/8-11 X 5	9	8	NNSH5/8-11	NUT, SQUARE, 5/8-11
2	1	1345027	FRAME, WELDMENT TAPE EDGE "Q"	10	40	SSHC10112	SCREW, HEX, 5/16-18 X 1-3/4
3	2	13451019	GEAR RACK, SHORT	11	8	SSSC10080	5/16-18 X 1-1/4 SOC CAP
4	2	13451020	GEAR RACK, LONG	12	4	SSHC98032	10-32 X 1/2 HEX HD
5	4	13451021	GEAR RACK, CORNER, 10 DP, 84 TEETH, 1" THK	13	4	WWFS10	WASHER, FLAT, #10, SAE
6	1	1345495	CONTROL BOX, HIGH VOLTAGE	14	4	WWL10	WASHER, LOCK, #10
7	8	IIS016X112	ROLL PIN 1/8 DIA X 1 1/2 SS	15	40	WWL5/16	WASHER, LOCK, 5/16
8	4	MML-2	LEVELING PAD, 5/8-11				

# 13452500A Frame Lift Table – Revision 12

AAC Drawing Number 9001366 Rev 1?

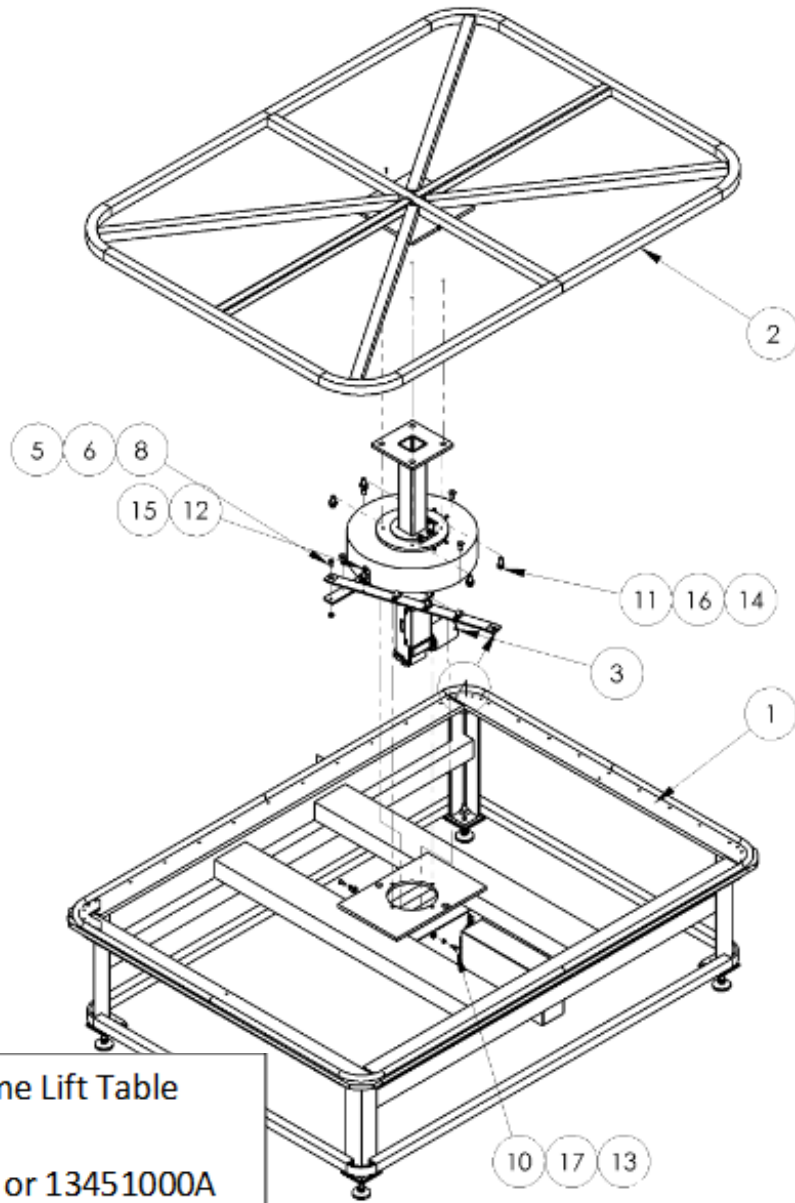

**Note :** Verify your model of Frame Lift Table before ordering parts for table  
**Options:** 13451000, 1345485 or 13451000A

ITEM	QTY	PART NUMBER	DESCRIPTION	ITEM	QTY	PART NUMBER	DESCRIPTION
1	1	13451000A	BASE ASSY LIFT TABLE TAPE	10	2	SSHC10048	5/16-18 X 3/4 HHCS
2	1	13451200	TABLE TOP ASSY,QUEEN	11	4	SSHC45080	1/2-13X1-1/4 HEX CAP
3	1	13452000D	COLUMN, LIFT ASSY	12	4	SSSC98032	10-32X1/2, SOC CAP
4	1	13452027	LINK, CABLE ASSY,TWIN	13	2	WWF5/16	WASHER,FLAT,5/16
5	2	BBTRA613	WASHER,THRUST,STL, .375B	14	4	WWFS1/2	WASHER,FLAT,1/2, SAE
6	1	NNJ5/16-18	NUT,JAM,5/16-18	15	4	WWFS10	WASHER, FLAT, #10, SAE
7	4	PPP2217	WIRE CLAMP, .337I.D.	16	4	WWL1/2	1/2 LOCK WASHER
8	1	SSFC10056S	10-32 x 2 FLAT ALLEN	17	2	WWL5/16	WASHER,LOCK, 5/16
9	4	SSFC45064	1/2-13 X 1 SOC FLAT CAP				

Service Instructions

**13451000A Lift Table Base Assembly**

AAC Drawing Number 9009186 Rev 0

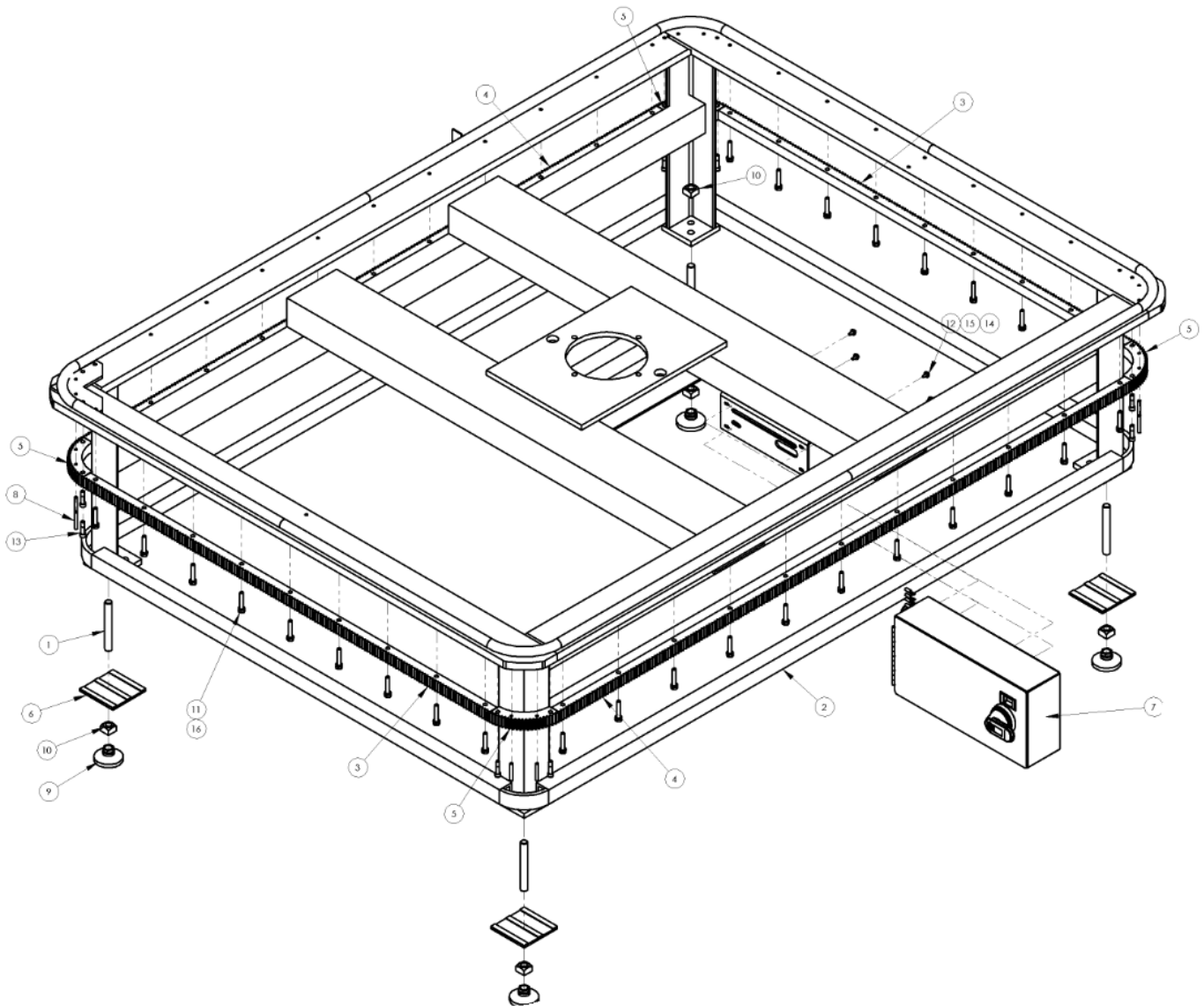

ITEM	QTY.	PART NUMBER	DESCRIPTION	ITEM	QTY.	PART NUMBER	DESCRIPTION
1	4	0411-1063	ROD, THREADED, 5/8-11 X 5	9	4	MML-2	LEVELING PAD, 5/8-11
2	1	1345027	FRAME, WELDMENT	10	8	NNSH5/8-11	NUT, SQUARE, 5/8-11
3	2	13451019	GEAR RACK, SHORT	11	40	SSHC10112	SCREW, HEX, 5/16-18X1-3/4
4	2	13451020	GEAR RACK, LONG	12	4	SSHC98032	10-32X1/2 HEX HD
5	4	13451021	GEAR RACK, CORNER	13	8	SSSC10080	5/16-18 X 1-1/4 SOC CAP
6	4	13451029	PAD, RUBBER	14	4	WWFS10	WASHER, FLAT, #10
7	1	<b>1345495</b>	CONTROL BOX	15	4	WWL10	WASHER, LOCK, #10
8	8	IIS016X112	ROLLPIN 1/8 DIA X 1 1/2 SS	16	40	WWL5/16	WASHER, LOCK, 5/16

# 13452000D Column Lift Assembly

AAC Drawing Number 9002809 Rev 4

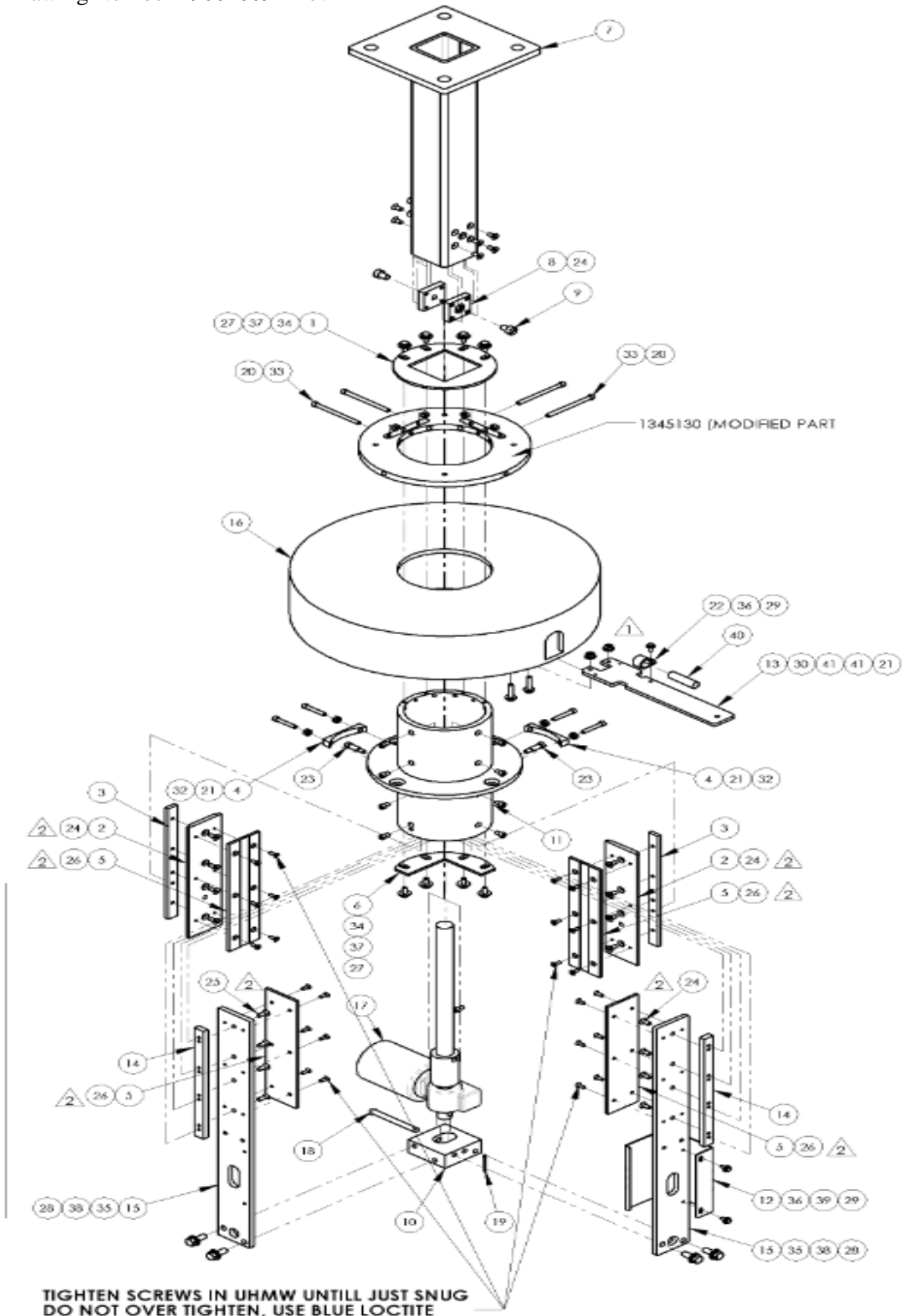

Service Instructions

13452000D parts list

ITEM	QTY.	PART NUMBER	DESCRIPTION	ITEM	QTY.	PART NUMBER	DESCRIPTION
1	1	1345093	BKT,EDGE GUIDE	22	4	NNK1/4-20	NUT,KEP,1/4-20
2	1	1345130	MODIFICATION ONLY SLIP RING	23	2	NNK10-32	KEP NUT, 10-32
3	2	1345131	PLATE,SLIDE, ADJ	24	1	PPP2217	WIRE CLAMP, .337I.D.
4	2	1345132	BAR, BRACE,.25 THK	25	2	SSAS020048	SCREW,ALLEN SHOULDER
5	2	1345134	SPACER,COLUMN	26	20	SSFC01032	1/4-20 X 1/2 FLAT ALN CAP
6	4	1345135	PLATE, SLIDE	27	4	SSFC01040	1/4-20 X 5/8 FLAT ALN CAP
7	1	1345136	BKT,LOWER GIB STOP	28	24	SSFC98032	10-32 X 1/2 FLAT ALLEN CAP
8	1	1345231	COLUMN ASSY	29	8	SSHC01040	1/4-20 X 5/8 HHCS
9	2	1345234	PLATE,ACTUATOR MNTNG,UPR	30	4	SSHC25064	3/8-16 X 1 HHCS
10	2	13452004A	PIN, COLUMN	31	3	SSHC98032	10-32X1/2 HEX HD
11	1	13452006B	PLATE, ACTUATOR	32	2	SSHC98080	#10-32 X 1-1/4 HEX CAP
12	1	13452020B	COLUMN, HUB ASSY.	33	9	SSSC01024	1/4-20 X 3/8 SOC CAP SC
13	1	13452023A	COVER, ACTUATOR	34	4	SSSC01096F	1/4-20 X 1-1/2 SOC CAP
14	1	13452024	GUIDE ASSY,CABLE, SLIP RING 11345	35	4	SSSC01224T	SCR,HEX CAP 1/4-20X3-1/2
15	2	13452040	BAR, BRACE	36	8	WWF1/4	WASHER, FLAT, 1/4", COM
16	2	13452044A	PLATE,SLIDE SUPPORT	37	4	WWFS3/8	WASHER,FLAT,SAE,3/8
17	1	EERHU-B08	SLIP RING ASSY,15A,8 COND	38	7	WWFS10	WASHER, FLAT, #10, SAE
18	1	MM85200-12.5	ACTUATOR,ELEC,220V,12.5"	39	8	WWL1/4	WASHER,LOCK,1/4
19	1	MM98306A289	PIN,CLEVIS,3/8X3-1/2	40	4	WWL3/8	WASHER,LOCK, 3/8
20	1	MM98338A445	COTTER PIN, 1/8 X 2 1/2	41	2	WWL10	WASHER,LOCK,#10
21	4	NNH1/4-20	NUT,HEX,1/4-20	42	1	ZTH1/2B	HEAT SHRINK TUBE,1/2"DIA

Service Instructions

1345495 Control Box

AAC Drawing Number 1345495 Rev 2

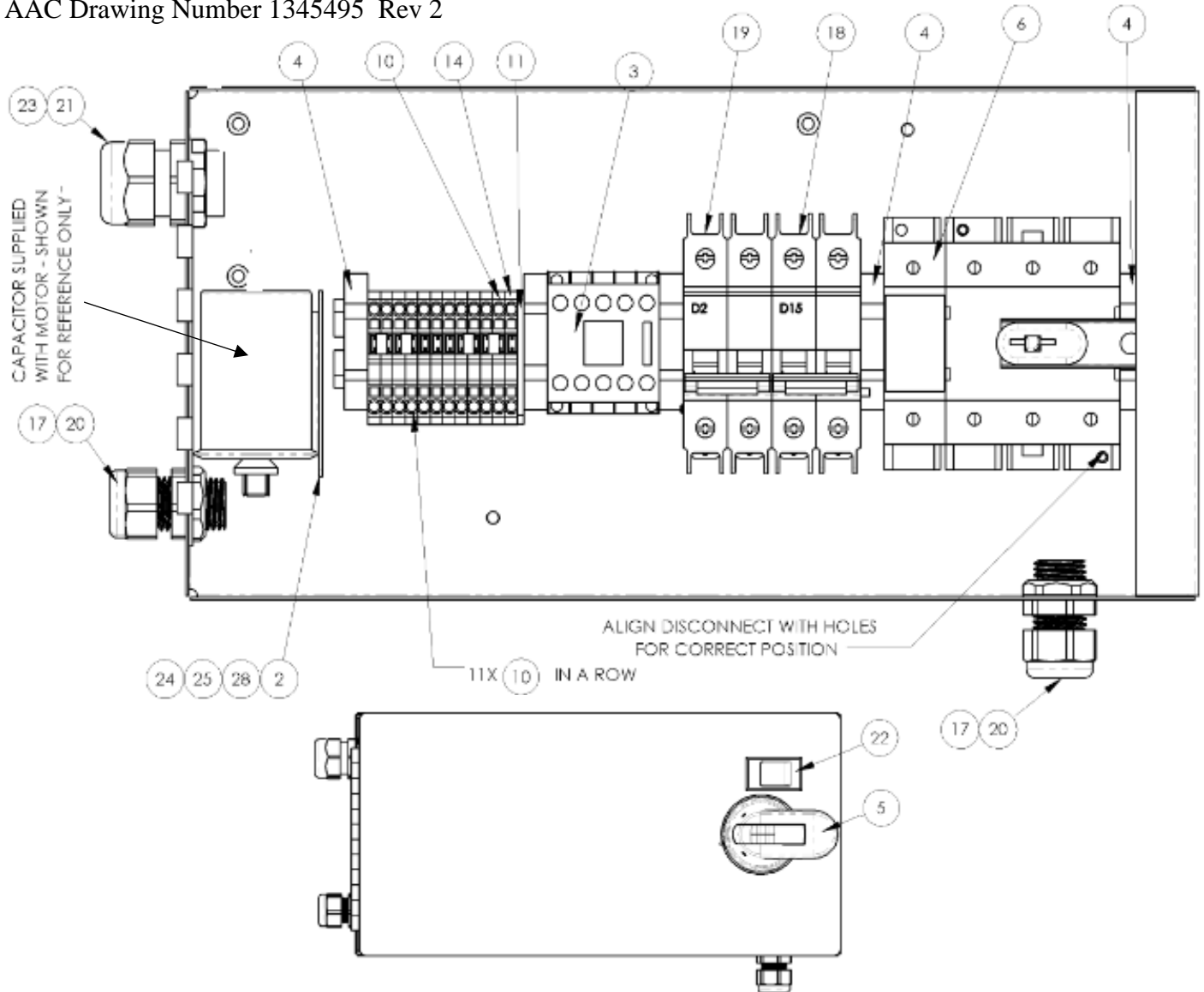

ITEM	QTY	PART NUMBER	DESCRIPTION	ITEM	QTY	PART NUMBER	DESCRIPTION
1	1	1345483	BOX, HIGH VOLTAGE CONTROL	15	15'	FF19511	CABLE, 3 COND, 14 AWG, SJTOW
2	1	13459004A	MOUNTING BRACKET, CAPACIT				
3	1	EECA491024	CONTACTOR, MINI, 240V	17	2	FF8463	NUT,LOCK, 1/2NPT,NYLON,BLK
4	5	EECLIPFIX	ANCHOR,DIN RAIL	18	1	FFFAZD152NA	BREAKER,2P,15A,UL489,240VT-MAG
5	1	EEHR65	DISCONNECT HANDLE,PISTOL	19	1	FFFAZD22NA	BREAKER,2P, 2A,UL489,240VT-MAG
6	1	EEM30U3M	DISCONNECT ASSY, 3PH, 30A	20	2	FFM3200	STRAIN RELIEF, 1/2NPT, .26-.55, BLK
7	1	EESPA210-2.85	DISCONNECT SHAFT,MOD	21	1	FFM3234	STRAIN RELIEF, 3/4NPT, .44-.71 BLK
8	13"	EETS35X7.5A	DIN RAIL-AMERICAN	22	1	MM40450010	FASTENER,SLIDE LOCK
9	1	FF209-502	MARKER, WAGO, TOP, #1-10	23	1	RB8465	LOCK-NUT,NYLON,3/4NPT
10	1	FF209-503	MARKER,WAGO, TOP, 11-20	24	5	SSPP90020	SCREW, #8-32 X 5/16, PAN HD PHIL
11	1	FF280-308	TERMBLK ENDPLATE,WAGO,280	25	3	SSPS98024	10-32X3/8 PAN HD SLOT
12	4	FF280-402	JUMPER,WAGO, TOP, SNGL	26	4	TT5811	TERMINAL,RING, #10 STUD
10	11	FF280-901	TERMBLK,WAGO, TOP, SNGL, GRY	27	3	WWF8	WASHER, FLAT, #8
14	1	FF280-907	TERMBLK,WAGO, TOP, SNGL, GRN	28	3	WWL8	WASHER, LOCK, #8



# 1345474 Carriage Assembly

AAC Drawing Number 1345474 Rev 1

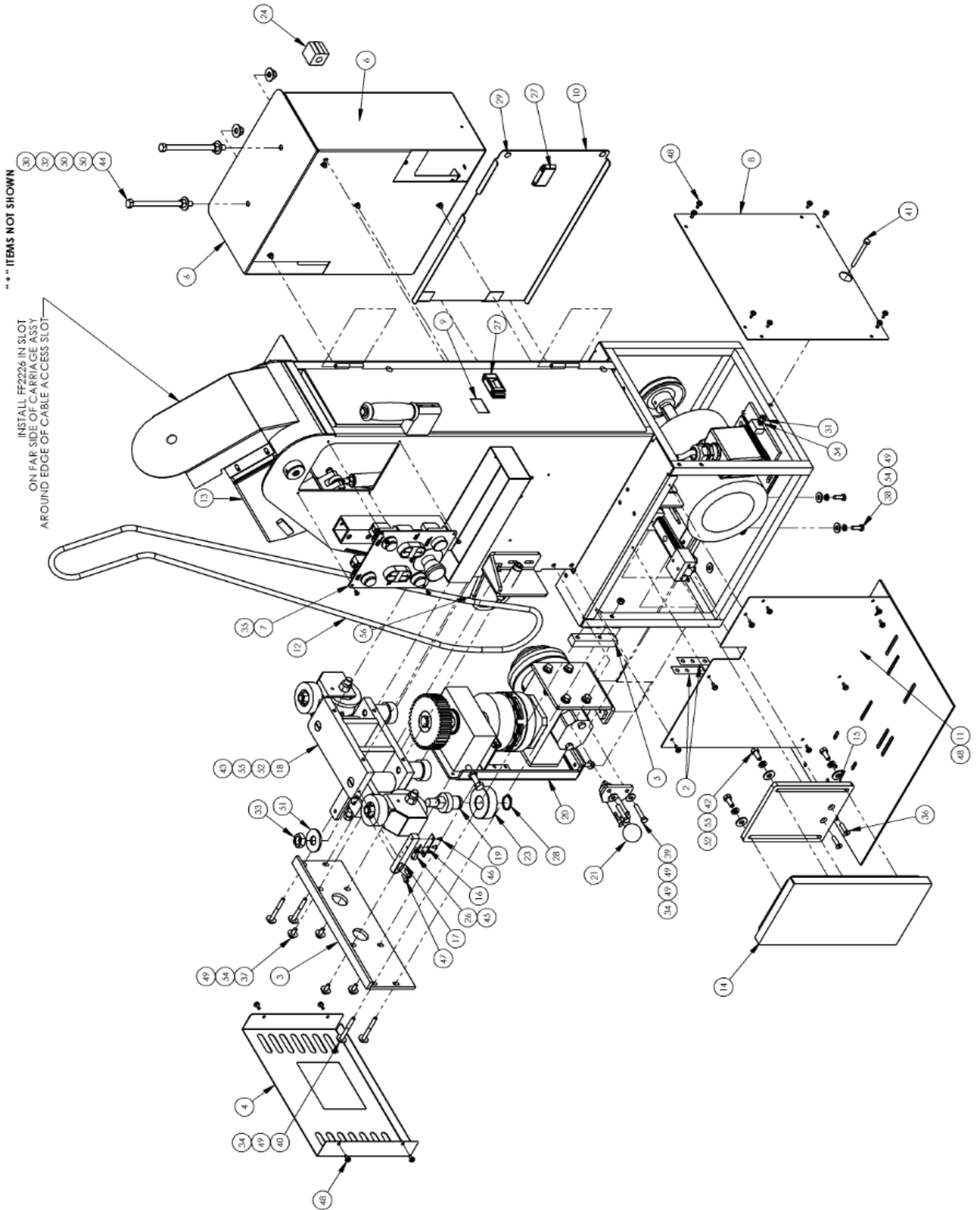

1345474 parts list

ITEM	QTY	PART NUMBER	DESCRIPTION	ITEM	QTY	PART NUMBER	DESCRIPTION
1	1	1345-2CWD	WIRING DIAGRAM	29	4	MMSLD-ECH	1/2" DIA RUBBER BUMPER
2	1	1345049	SHIM. .015 S/S	30	2	NNE3/8-16	NUT, ELASTIC 3/8-16
3	1	1345162	PLATE, MOUNTING, GEARBOX	31	1	NNH1/4-20	NUT, HEX, 1/4-20
4	1	1345163	COVER, CARRIAGE, FRONT	32	2	NNH3/8-16	NUT, HEX, 3/8-16
5	2	1345168	SPACER, GEARBOX MOUNT	33	1	NNH5/8-18	NUT, HEX, 5/8-18
6	1	1345475	CARRIAGE CONTROL BOX ASSY	34	6	NNK1/4-20	NUT, KEP, 1/4-20
7	1	1345482	CONTROL, BUTTON PANEL	35	4	SSBC90016	8-32 X 1/4 BUTTON CAP
8	1	13453003	COVER, CARRIAGE, REAR	36	2	SSFC01064	1/4-20 X 1 FLAT CAP
9	1	13453060	DOOR, CARRIAGE, REAR	37	4	SSHC01040	1/4-20 X 5/8 HHCS
10	1	13453061	DOOR, CARRIAGE, RH	38	2	SSHC01048	1/4-20 X 3/4 HEX CAP
11	1	13453062	COVER, CARRIAGE LH	39	2	SSHC01096	1/4-20 X 1-1/2 HHCS
12	1	13453211A	BELT, DRIVE, 10MMX107 IN	40	4	SSHC01144	HEX HEAD, 1/4-20 X 2-1/4
13	1	13453300A	TOP CARRIAGE ASSY.	41	1	SSHC01160T	SCREW, HEX CAP
14	1	13453303	KNEE PAD ASSY.	42	4	SSHC10048	5/16-18 X 3/4 HHCS
15	1	13453304	BRKT ,MNT, KNEE PAD	43	4	SSHC10064	5/16-18 X 1 HHCS
16	1	13453379	HOLDER, PROX SWITCH, BTM	44	2	SSHC25352	3/8-16X5-1/2, HEX CAP
17	1	13453380	HOLDER, PROX. SWITCH	45	1	SSPS50024	2-56 X 3/8 PAN HD SC
18	1	13453400A	CARRAGE GUIDE ASSY.	46	2	SSPS80016	#6-32 X 1/4 LG PAN HD
19	1	13453420A	BEARING STUD, INNER	47	2	SSSC98032	10-32X1/2, SOC CAP
20	1	13453500E	GEAR BOX ASSEMBLY	48	20	SSZS93032	SCREW, SHT. METAL 10 ZIP
21	1	13453800	GEAR LOCK ASSY.	49	16	WWF1/4	WASHER, FLAT, 1/4", COM
22	1	13459400	CABLE PACKAGE	50	4	WWF3/8	WASHER, FLAT, 3/8 OR 10MM
23	1	BB305705C	BEARING, CAM ROLLER	51	1	WWF5/8	WASHER, FLAT, 5/8
24	1	EE64151B	FERRITE CORE, SPLIT, CABLE	52	7	WWF5/16	WASHER, FLAT, 5/16
25	1	FF2226	EDGING, GROMMET	53	1	WWF5/16S	WASHER, FLAT, 5/16 NARROW
26	1	FFUZP111	PROX SENSOR, SUNX	54	9	WWL1/4	WASHER, LOCK, 1/4
27	2	MM40450010	FASTENER, SLIDE LOCK	55	8	WWL5/16	WASHER, LOCK, 5/16
28	1	MMSH-98	RING, SNAP, EXTERNAL	56	1	ZX3824	V-BELT, 3/8 X 24"

# 1345475 Carriage Control Box

AAC Drawing Number 1345475 Rev 0

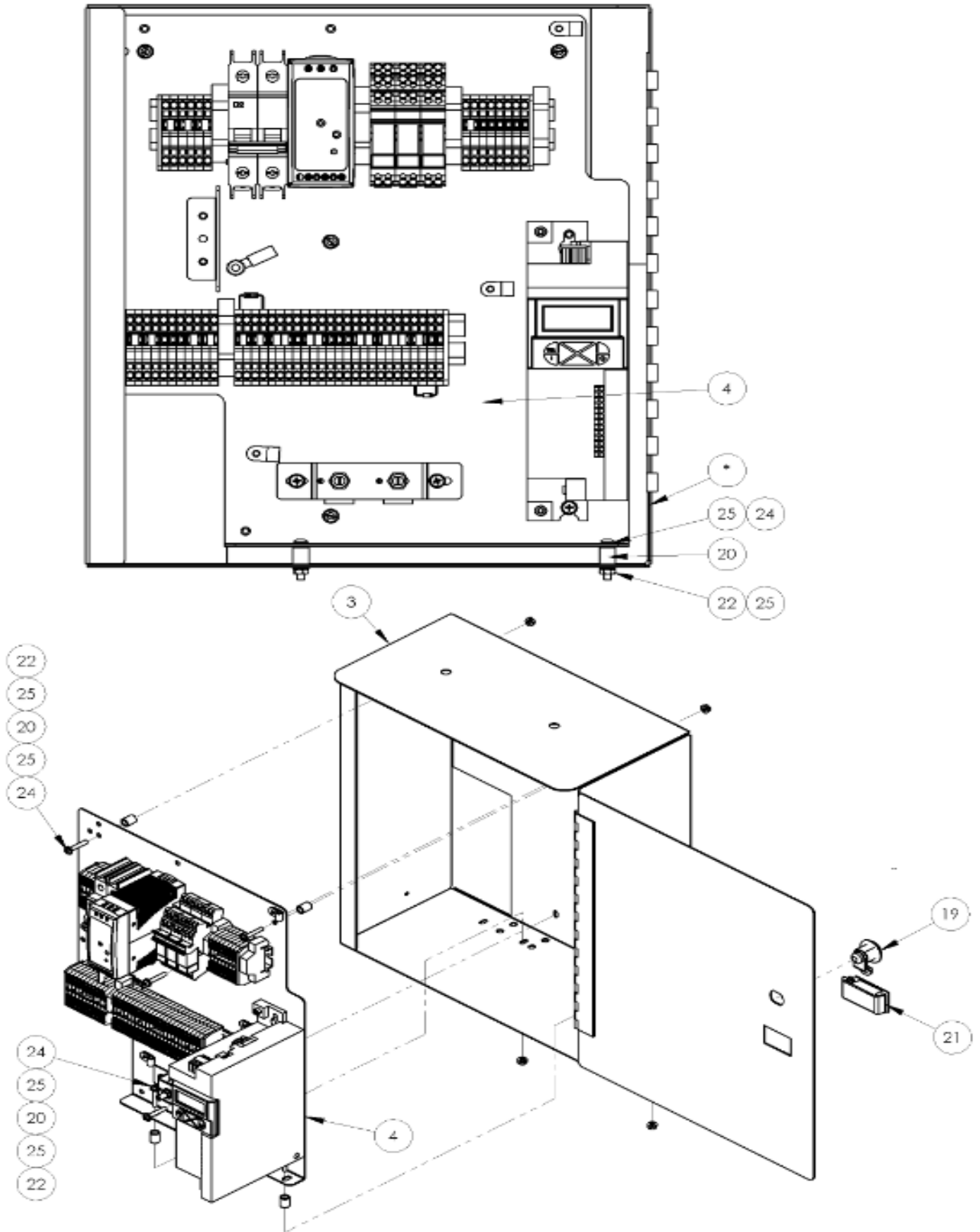

## 1345475 parts list

ITEM NO.	QTY	PART NUMBER	DESCRIPTION
1	*1	1345-2CWD	WIRING DIAGRAM
2	*1	1345LAB1	LABEL
3	1	1345476	CONTROL BOX 11345
4	1	1345480	PANEL, ELECTRICAL CONT 11345-2C
5	*1	EE14-4	CABLE,4 COND,14 AWG,SJOOW
6	*1	FF1293C	CABLE, 22X3 AWG
7	*1	FF3077-2	WIRE, STR, #16, PVC, BLK UL1015
8	*1	FF3077-3	WIRE, STR, #16, PVC, RED UL1015
9	*1	FF3077-6	WIRE, STR, #16, PVC, BLU UL1015
10	*1	FF3077-7	WIRE, STR, #16, PVC, BRN UL1015
11	*1	FF3077-28	WIRE, STR, #16, PVC,GRN/YEL
12	*1	FF3251-1	WIRE,STR,#22,SRPVC,WHT
13	*1	FF3251-2	WIRE,STR,#22,SRPVC,BLK
14	*1	FF3251-3	WIRE,STR,#22,SRPVC,RED
15	*1	FF3251-5	WIRE,STR,#22,SRPVC,YEL
16	*1	FF3251-6	WIRE,STR,#22,SRPVC,BLU
17	*1	FF3251-8	WIRE,STR,#22,SRPVC,ORN
18	*1	FF7439A	CABLE, 9 COND, 14AWG, HI FLEX PVC
19	1	MM1770A12	DOOR LATCH, CAM, KEYED
20	6	MM9376K141	ISOLATOR, URETHANE
21	1	MM40450010	FASTENER,SLIDE LOCK
22	6	NNK8-32	NUT,KEP,8-32
23	1	SSPP90032	SCREW,#8-32 X 1/2, PAN HD, PHIL
24	6	SSPS90064	8-32 X 1 PAN HD
25	13	WWF8	WASHER, FLAT, #8

Service Instructions

**1345480 Electrical Panel**

AAC Drawing Number 1345480 Rev 0

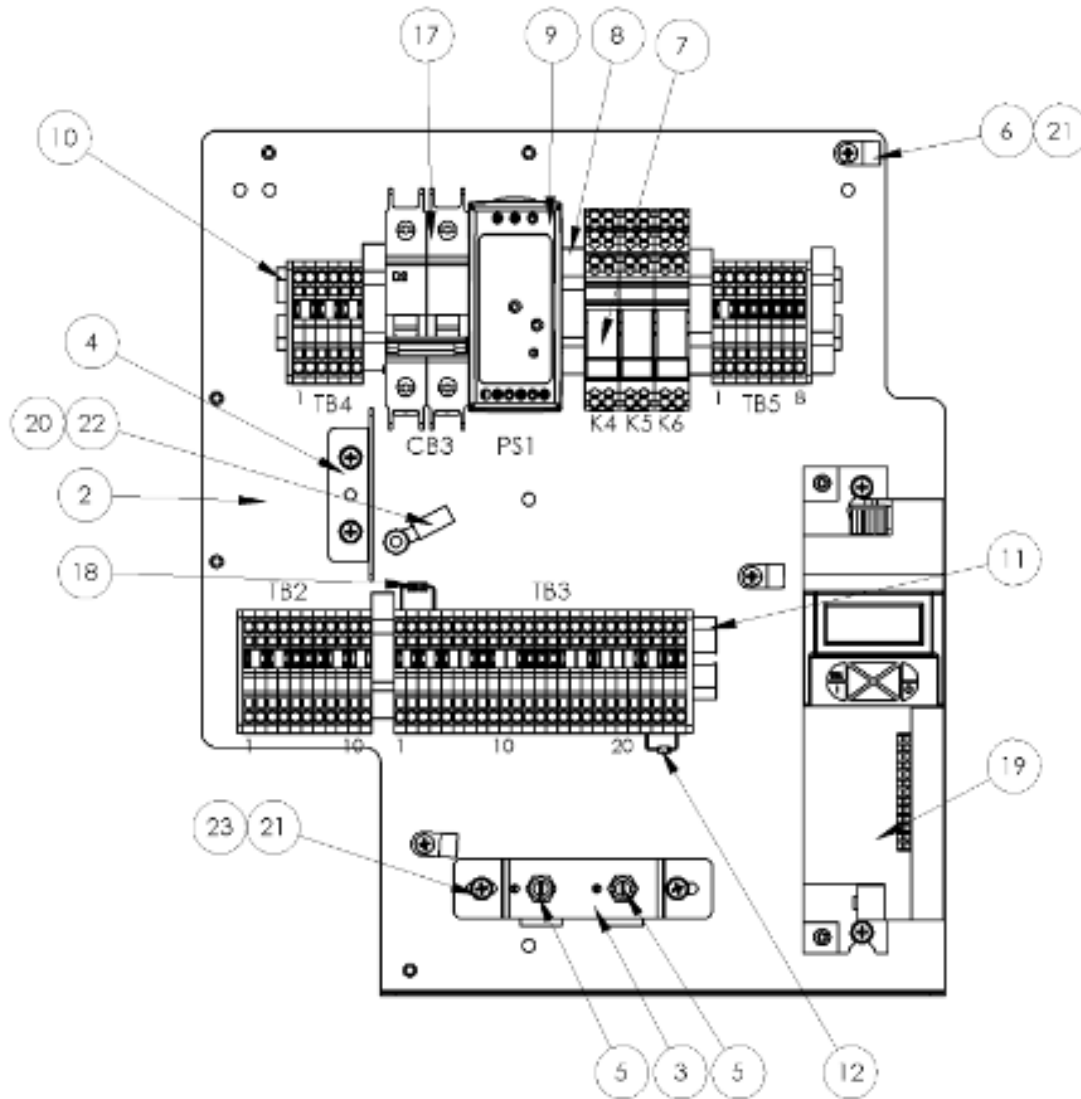

ITEM NO.	QTY.	PART NUMBER	DESCRIPTION	ITEM NO.	QTY.	PART NUMBER	DESCRIPTION
1	1	1345-2CWD	WIRING DIAGRAM	13	4	FF280-308	TERMBLK ENDPLATE,WAGO,280
2	1	1345478	SUB PANEL,CARRIAGE	14	20	FF280-402	JUMPER,WAGO,TOP,SNGL
3	1	13459003A	BRKT, MOUNTING, 2 POT, -2	15	51	FF280-901	TERMBLK,WAGO,TOP,SNGL,GRY
4	1	13459004A	MOUNTING BRACKET, CAPACIT	16	2	FF280-907	TERMBLK,WAGO,TOP,SNGL,GRN
5	2	13459008	POT,5K,1 TURN,PNL.,.5W	17	1	FFFAZD22NA	BREAKER,2P, 2A,UL489,240VT-MAG
6	3	AAF3/16	CLAMP, BLACK PLASTIC, 3/16 DIA	18	1	FFR1K	RESISTOR, 1K, 1/4W
7	3	EE788312	RELAY,24V,DPDT,WAGO	19	1	MM510175B1M2	DRIVE,VFD,I510,1HP
8	5	EECLIPFIX	ANCHOR,DIN RAIL	20	1	NNK10-32	KEP NUT, 10-32
9	1	EEMDR6024	PWR SUPPLY, SWTR, 24V, 2.5A, DIN	21	3	SSPP90020	SCREW,#8-32 X 5/16, PAN HD PHIL
10	1	EETS35X7.5A	DIN RAIL-AMERICAN	22	1	TI5828	TERMINAL,RING,#10STUD
11	1	EETS35X7.5A	DIN RAIL-AMERICAN	23	4	WWF8	WASHER, FLAT, #8
12	1	FFIN4937	DIODE,FAST 200NS,1A				

Service Instructions

**1345482 Control Button Panel**

AAC Drawing Number 1345482 Rev1

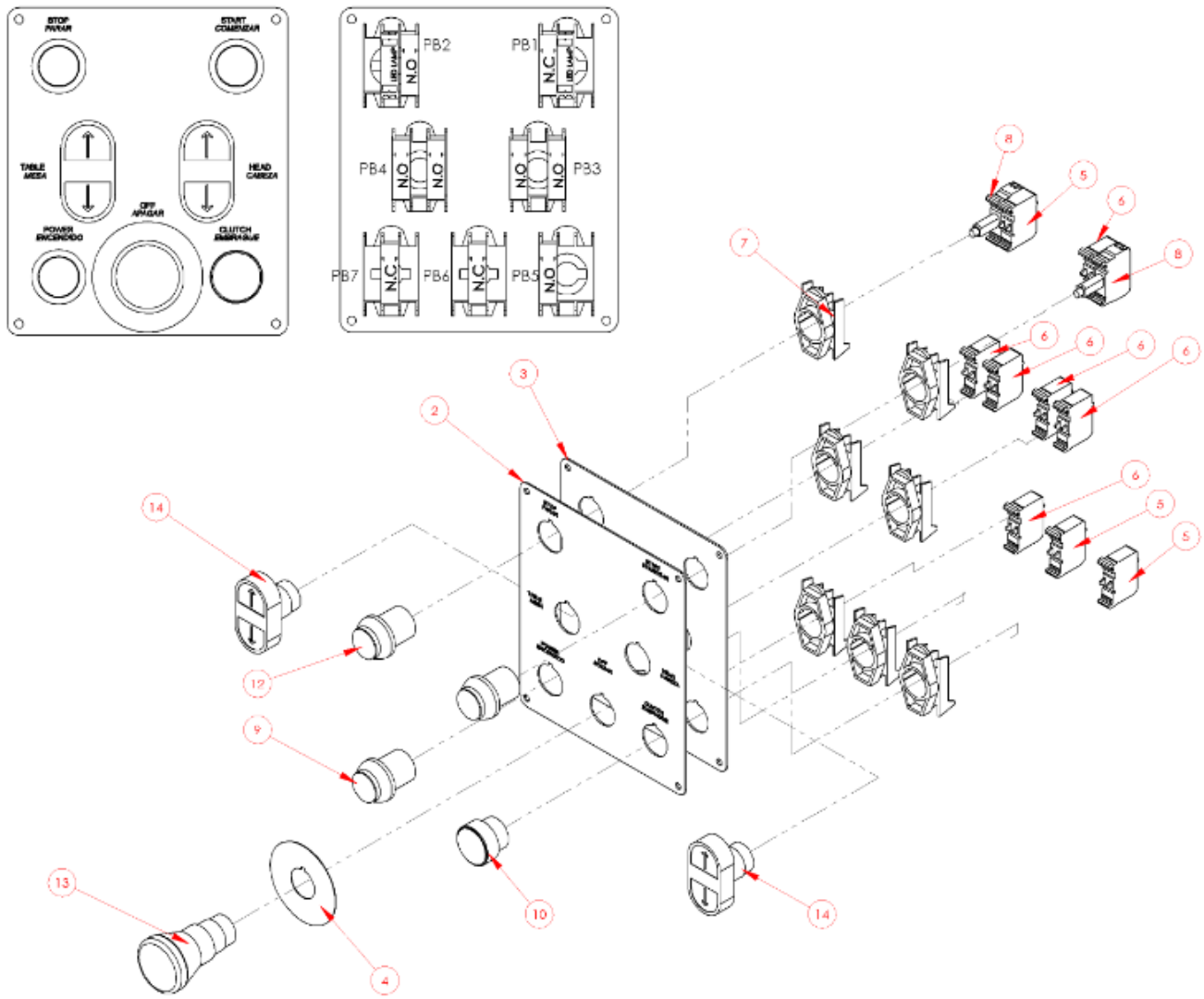

ITEM	QTY	PART NUMBER	DESCRIPTION	ITEM	QTY	PART NUMBER	DESCRIPTION
1	1	1345-2CWD	WIRING DIAGRAM	10	1	EEPFA6	BUTTON, PUSH, BLU, FLUSH
2	1	13452LAB	LABEL, SWITCH PANEL	11	1	EEPLE3	BUTTON, PUSH, GRN, ILLUM
3	1	13459301	PANEL, SWITCH	12	1	EEPLE4	BUTTON, PUSH, RED, ILLUM
4	1	EE15Y	PLATE, LEGEND, YELLOW	13	1	EEPMTS44	E-STOP BUTTON, TWIST REL.
5	3	EE3Q01	CNTK BLOCK, N.C. (RED) SPNG TERM	14	2	EEPU2A3	BUTTON, PUSH 22MM, 2X,G MOM FLUSH
6	6	EE3Q10	CNTK BLOCK, N.O. (GRN) SPNG TERM	15	3'	FF18988C	CABLE, 8 COND, 18GA
7	7	EEA3L	LATCH, PUSH BUTTON	18'		FF19511	CABLE, 3 COND, 14 AWG, S JTOW
8	2	EED7-Q3W	LED BLOCK, 22MM, 24V LAMP	17	8	TTDBNYDS218	TERM, FLAT BLADE, INS, 14 AWG, BLUE
9	1	EEPE3	BUTTON, PUSH, GRN, NON-ILLUM				



Service Instructions

13453300A parts list

NO.	QTY	PART #	DESCRIPTION	NO.	QTY	PART #	DESCRIPTION
1	2	029-003A	PLATE, NUT, 1/4-20 @ 1.50	24	2	MM98335A064	SPRING CLIP
2	1	13453064	COVER, BELT, UPPER	25	1	MMCYR114S	FOLLOWER, CAM
3	1	13453065	COVER, BELT, LOWER	26	1	MMGP-105	GRIP HANDLE-FOAM 3/4 ID
4	1	13453100A	CARRIAGE, FRAME ASSY.	27	2	MMVA4001	PULLEY
5	1	13453202	CLEVIS, ACTUATOR	28	1	NNJ3/8-24	3/8-24 JAM NUT
6	1	13453204	SHAFT 60C 1/2 X 9.10 L	29	2	NNJ3_4-16	3/4-10 JAM NUT
7	2	13453205	HUB, IDLER PULLEY	30	2	SSBC01032	1/4-20 X 1/2 BUT CAP SC
8	1	13453210	MOUNT, SEW HEAD, PIVOTING	31	2	SSBC01040	1/4-20 X 3/4 BUT CAP SC
9	1	13453301	MOUNT, SHOCK ABSORBER	32	2	SSBC98016	10-32 X 1/4 BUTTON CAP SC
10	1	13453313	MOUNT, CARRIAGE GUIDE, LO	33	4	SSBC98032	10-32 X 1/2 BUTTON CAP SC
11	1	13453341	TOOL TRAY, 2 X 3.38 X 11	34	2	SSBC98072	SCREW,BUTTON CAP
12	1	13453354	BRKT, THREAD GUIDE	35	2	SSHC01064	1/4-20 X 1 HHCS
13	1	13453370	KNEE SWITCH ASSY.	36	1	SSHC25080	3/8-16 X 1-1/4 HEX CAP
14	1	13453378	WELDMENT,PIVOT SUPPORT	37	9	SSSC01048	1/4-20 X 3/4" SOC CAP SC
15	1	13453385	HOLDER, SCISSOR	38	2	SSSC01096	1/4-20 X 1-1/2 SOC CAP
16	1	13453390A	MOTOR ASSEMBLY	39	6	SSSC98032	10-32X1/2, SOC CAP
17	1	33005110	HANDLE 6.5 L	40	4	SSSS01032	1/4-20 X 3/8 NYLON PT
18	1	33005116	SPACER, HANDLE MOUNT	41	17	WWFS1/4	WASHER,FLAT,SAE,1/4
19	1	AAOEM.5BSAL	SHOCK, 3/4-18 X 3.5	42	10	WWFS10	WASHER, FLAT, #10, SAE
20	1	EE49111AS	PUSH BUTTON SWITCH ASSY	43	17	WWL1/4	WASHER,LOCK,1/4
21	1	MM85151-2M1	ACTUATOR, MOD	44	10	WWL10	WASHER,LOCK,#10
22	1	MM9307K69	GROMMET,5/8,1.125,.125GV	45	1	WWL3/8	WASHER, LOCK, 3/8
23	2	MM98330A245	CLEVIS PIN 2.25LG STL	46	1	WWSI3/8	WASHER,INTERNAL TOOTH,3/8

**13453400A Carriage Guide Assembly**

AAC Drawing Number Rev 6

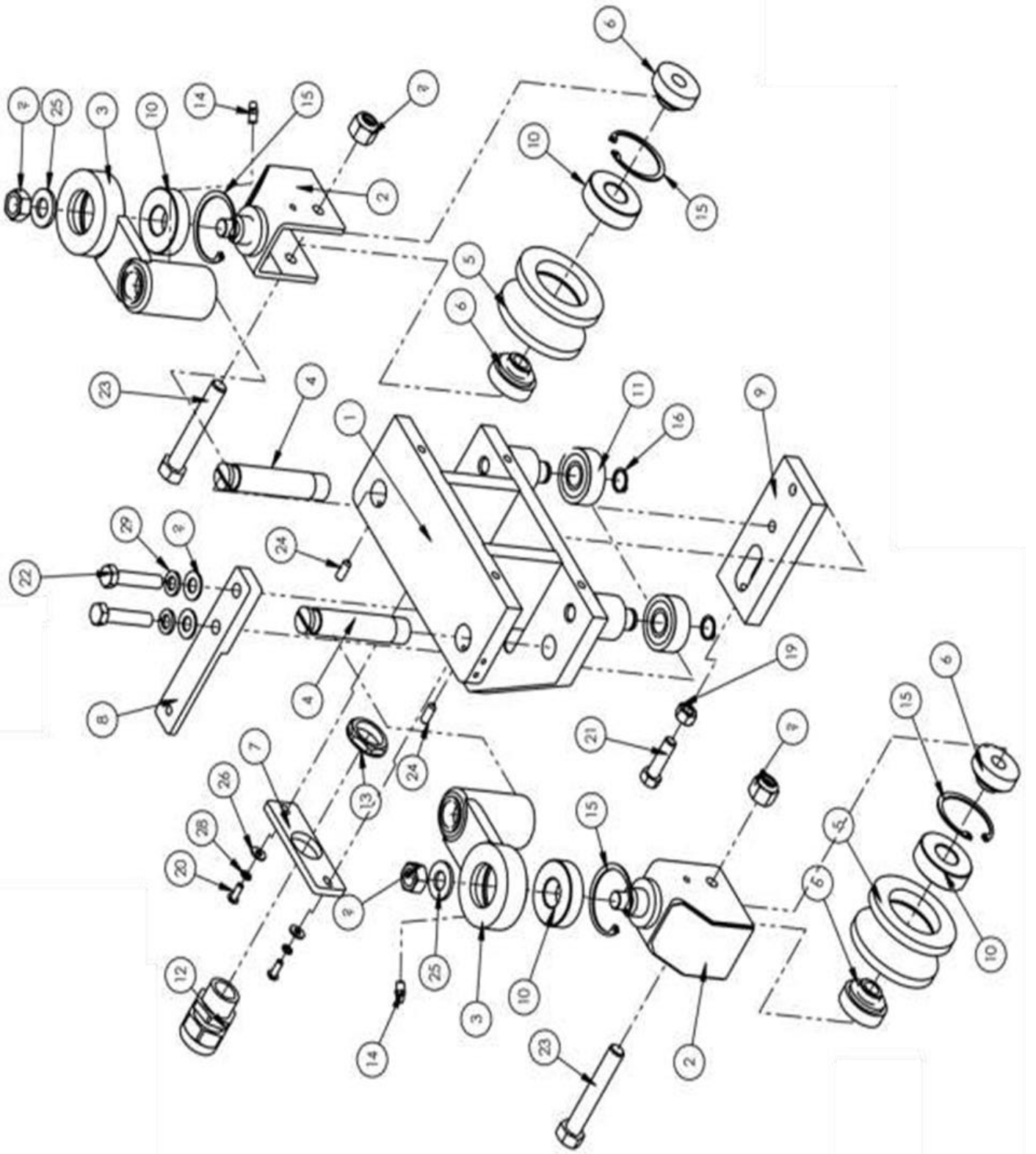

## 13453400A parts list

NO.	QTY	PART #	DESCRIPTION	NO.	QTY	PART #	DESCRIPTION
1	1	13453401A	CARRIAGE GUIDE FRAME ASSY	16	2	MMSH-59	CLIP RING EXT, .546 ID
2	2	13453404	ROLLER YOKE ASSY	17	2	NNE1/2-13	NUT,NYLOCK,1/2-13
3	2	13453408	GUIDE ARM ASSY.	18	2	NNH1/2-13	NUT,HEX,1/2-13
4	2	13453411	STUD, ROLLER BEARING	19	1	NNH3/8-16	3/8-16 HEX NUT
5	2	13453413	ROLLER, GUIDE	20	2	SSBC98032	#10-32 X 1/2 BUT HEAD
6	4	13453414	HUB, ROLLER GUIDE	21	1	SSHC25080	3/8-16 X 1-1/4 HEX HEAD
7	1	13453415	PLATE, CABLE HOLDER	22	2	SSHC25128	3/8-16 X 2 HEX HEAD
8	1	13453416	MOUNT, CABLE GUIDE	23	2	SSHC45192	1/2-13 X 3 HEX HEAD
9	1	13453418	MOUNT, BEARING BLOCK, REA	24	2	SSSS01040	SCREW, SET, 1/4-20 X 5/8
10	4	BB11017	BEARING,BALL,.787B	25	2	WWFS1/2	WASHER,FLAT,SAE,1/2
11	2	BB305702C	BEARING,CAMROLLER	26	2	WWFS10	WASHER, FLAT, #10, SAE
12	1	FF3460	STRAIN RELIEF, LIQ TIGHT	27	2	WWFS3/8	WASHER,FLAT,SAE,3/8
13	1	FF8465	NUT,LOCK,3/4NPT,NYLON,BLK	28	2	WWL10	#10 LW
14	2	MM1095K44	GREASE FITTING, 1/4-28	29	2	WWL3/8	WASHER, LOCK, 3/8
15	4	MMH0-185	CLIP RING INT,1.962 OD				

**13453370 Knee Switch Assembly**

AAC Drawing Number 9000382 Rev 5

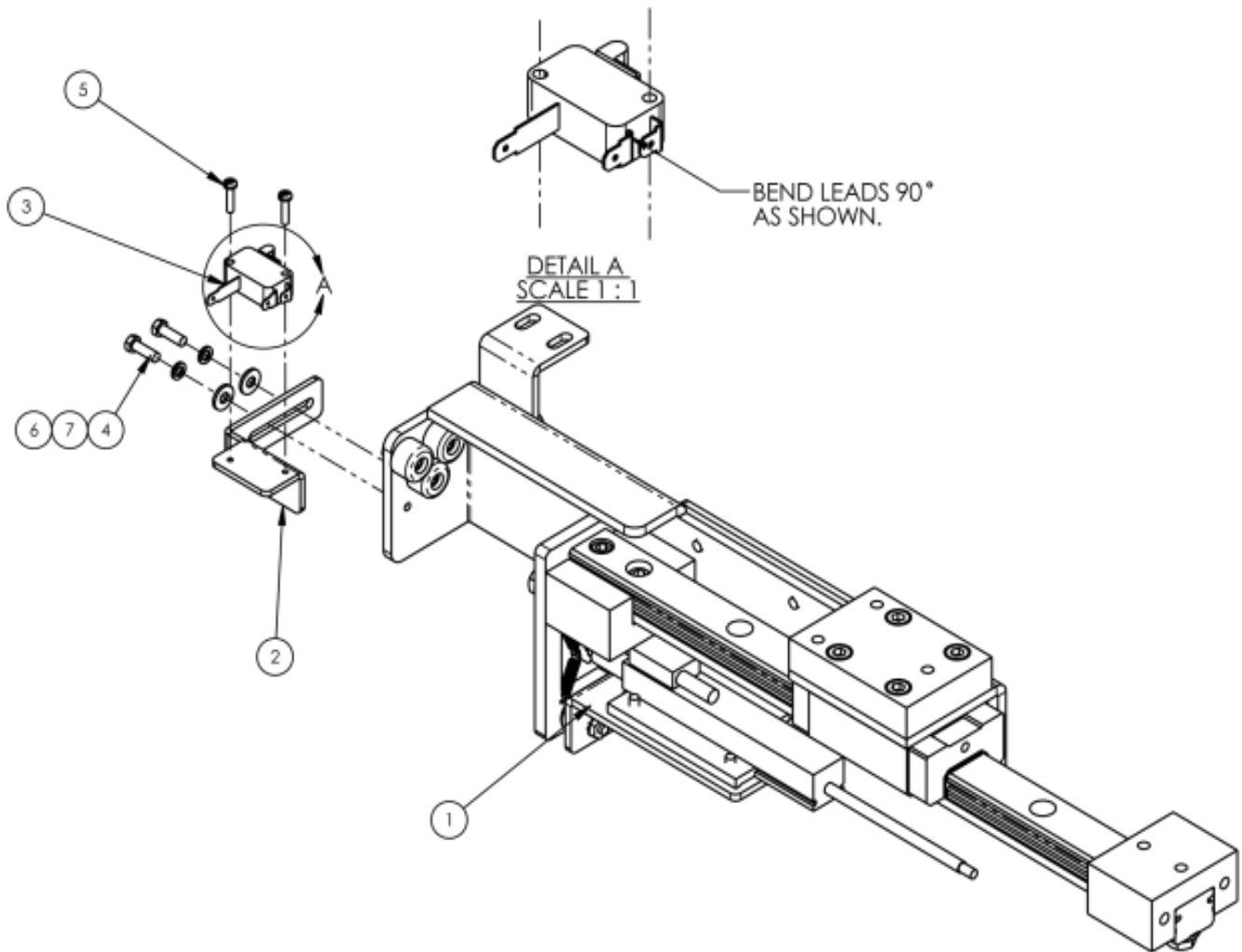

NO.	QTY	PART #	DESCRIPTION
1	1	1345100	KNEE SWITCH ASSEMBLY
2	1	13453332A	BRKT.,KNEE SENSOR
3	1	A-2014-39	MICRO SWITCH MODIFIED
4	2	SSHC90032S	#8-32 X 1/2 HEX CAP
5	2	SSPS70032	#4-40 X 1/2 PAN HD SLOT
6	2	WWF8	WASHER, FLAT #8
7	2	WWL8	WASHER, LOCK #8

**1345100 KNEW SWITCH ASSEMBLY**

AAC Drawing Number 1345100

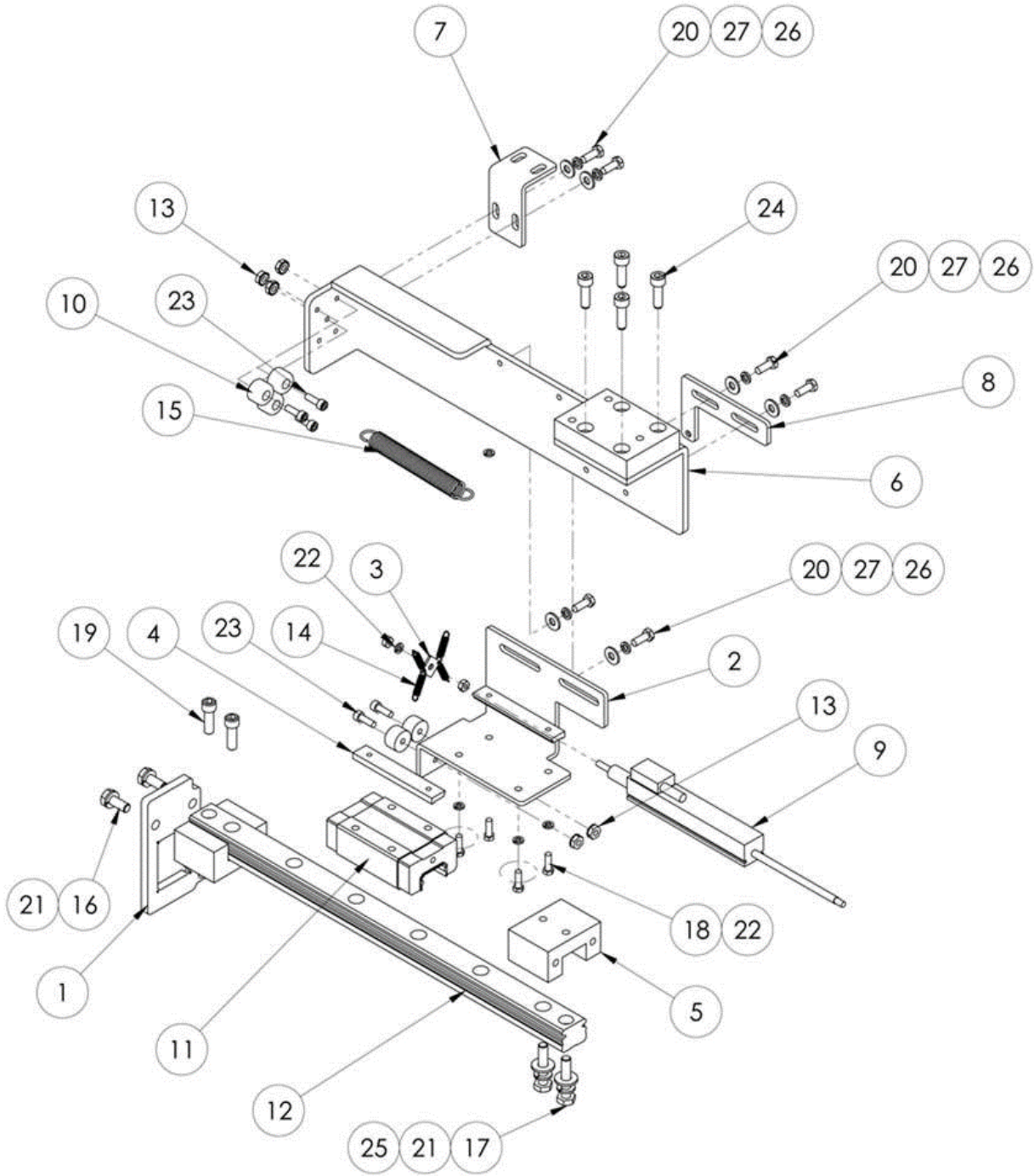

## 1345100 parts list

NO	QTY	PART #	DESCRIPTION
1	1	1345101	PLATE,TRANSDUCER END
2	1	1345102	MOUNT, TRANSDUCER
3	1	1345103	PLATE,SPRING,TRANSDUCER
4	2	1345104	CLAMP,TRANSDUCER
5	2	13453306	BLOCK,RAIL STOP
6	1	13453309	RAIL BKT ASBLY
7	1	13453337	BRACKET,RAIL SUPPORT
8	1	13453361	BRKT, SPRING TENSION
9	1	FF002304A	LINEAR TRANSDUCER ASBY
10	5	MM9540K53	BUMPER, 3/4 DIA
11	1	MMAGH25CAN	LINEAR BEARING
12	1	MMAGR25360M 1	RAIL,LINEAR,MODIFIED
13	5	NNK8-32	KEP NUT, 8-32
14	4	RRLE018B1	SPRING,EXT .020X.19X1.5
15	1	RRLE055E10	SPRING,EXT .020X.19X1.5
16	2	SSHC01040	1/4-20 X 5/8 HHCS
17	2	SSHC01080	1/4-20 X 1-1/4 HHCS
18	4	SSHC90032S	#8-32 X 1/2 HEX CAP
19	2	SSSC01048	1/4-20 X 3/4" SOC CAP SC
20	6	SSHC98032	10-32X1/2 HEX HD
21	4	WWL1/4	WASHER,LOCK, 1/4
22	5	WWL8	WASHER,LOCK,#8
23	5	SSSC90032	#8-32 X 1/2 SOC CAP SC
24	4	SSSCM6X20	M6 X 20, SOC CAP
25	2	WWFS1/4	WASHER,FLAT,SAE,1/4
26	6	WWFS10	WASHER, FLAT, #10, SAE
27	6	WWL10	WASHER,LOCK,#10

Service Instructions

**13453390A Motor Assembly**

AAC Drawing Number 9001194 Rev 5

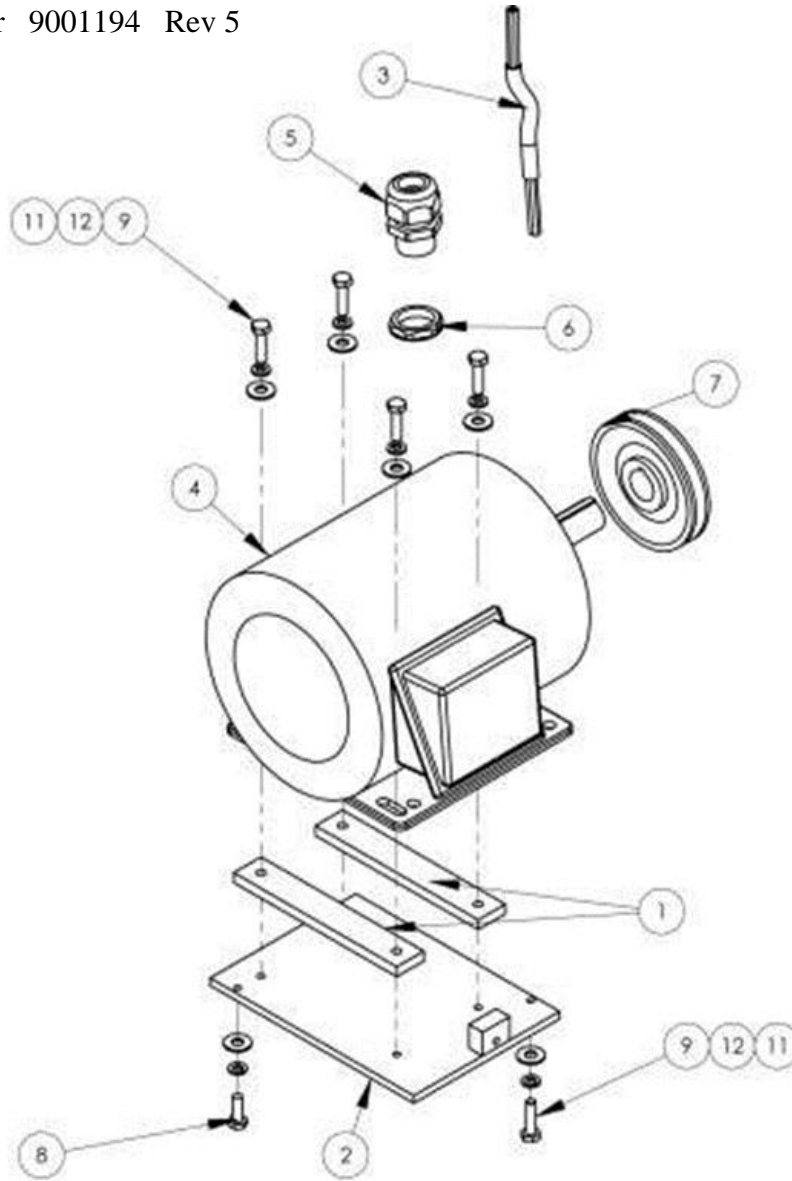

NO	QTY	PART #	DESCRIPTION
1	2	1345156	SPACER
2	1	13453328	PLATE, MOTOR MOUNT
3	1	EE14-4	CABLE,4 COND,14 AWG,SJOOW
4	1	EE4RX36	MOTOR,INVERT DUTY,1HP
5	1	FF3460	STRAIN RELIEF,LIQ TIGHT
6	1	FF8465	NUT,LOCK,3/4NPT,NYLON,BLK
7	1	PPM631M1	PULLEY, V BELT, MOTOR, 3.75 OD, MOD
8	1	SSHC01048	1/4-20 X 3/4 HEX CAP
9	5	SSHC01064	1/4-20 X 1 HHCS
10	4	W1061-3	NUT, WIRE
11	6	WWF1/4	WASHER, FLAT, 1/4", COM
12	6	WWL1/4	WASHER,LOCK, 1/4



## 13453500E parts list

NO	QTY	PART #	DESCRIPTION
1	1	132556-258	KEY, 3/16 X .813 L
2	1	1345041	NUT PLATE,1/4-20X3.25
3	1	1345167	BRKT, GEAR BOX, LOWER
4	1	1345176	BLOCK, BEARING MOUNTING
5	1	1345178	PLATE,GEAR BOX
6	AR	1345359	SHIM, BEARING MOUNTING
7	1	13453501	PLATE, CLUTCH ADAPTER
8	1	13453503B	SHAFT, GEAR DRIVE
9	1	13453512A	BRKT, ANTI ROTATE, CLUTCH
10	1	13453514	SPACER, CLUTCH
11	1	13453516	SLEEVE, CLUTCH
12	1	13453519A	PLATE,CLUTCH, LOWER
13	1	13453521A	PULLEY,DRIVE
14	1	13453522	SPACER, GEAR BOX
15	1	13453523	KEY,5MM X8MM X 1 1/4
16	2	13453524	KEY,3/16 X 1.68L
17	1	13453532	NUT PLATE,1/4-20X5.75
18	2	BBS8703-88	BEARING,BALL,.75IDX1.75OD
19	1	MM20UM1	GEAR BOX, MOD.
20	1	MM4534K42	PLUG, FLUSH, 1/4" PIPE
21	1	MM231572	COUPLING
22	1	MM231631M1	CLUTCH
24	1	MMS1040	GEAR, 40T, 10P
25	1	NNE10-32	NUT,ELASTIC LOCK
26	1	NNJ3/8-24	3/8-24 JAM NUT
27	4	SSFC80024	6-32 X 3/8 FLAT CAP
28	2	SSHCO1096	1/4-20 X 1-1/2 HHCS
29	2	SSHC10048	5/16-18 X 3/4 HHCS
30	8	SSHC10064	5/16-18 X 1 HHCS
31	1	SSHC35128F	3/8-24 X 2.0 FULL THD
32	3	SSHC98032	10-32X1/2 HEX HD
33	4	SSSCM6X15	M6X15 SOC CAP SCREW
34	2	SSSS01048	1/4-20 X 3/4
35	AR	SSSS98024	10-32X 3/8 SOC SET SC
36	2	WWF5/16S	WASHER,FLAT,5/16 NARROW
37	2	WWFS1/4	WASHER,FLAT,SAE,1/4
38	1	WWFS3/8	WASHER,FLAT,SAE,3/8
39	8	WWFS5/16	WASHER,FLAT,SAE,5/16
40	3	WWFS10	WASHER, FLAT, #10, SAE
41	2	WWL1/4	WASHER,LOCK, 1/4
42	10	WWL5/16	WASHER,LOCK, 5/16
43	2	WWL10	WASHER,LOCK,#10

**13453800 Gear Lock Assembly**

AAC Drawing Number 9001130 Rev 1

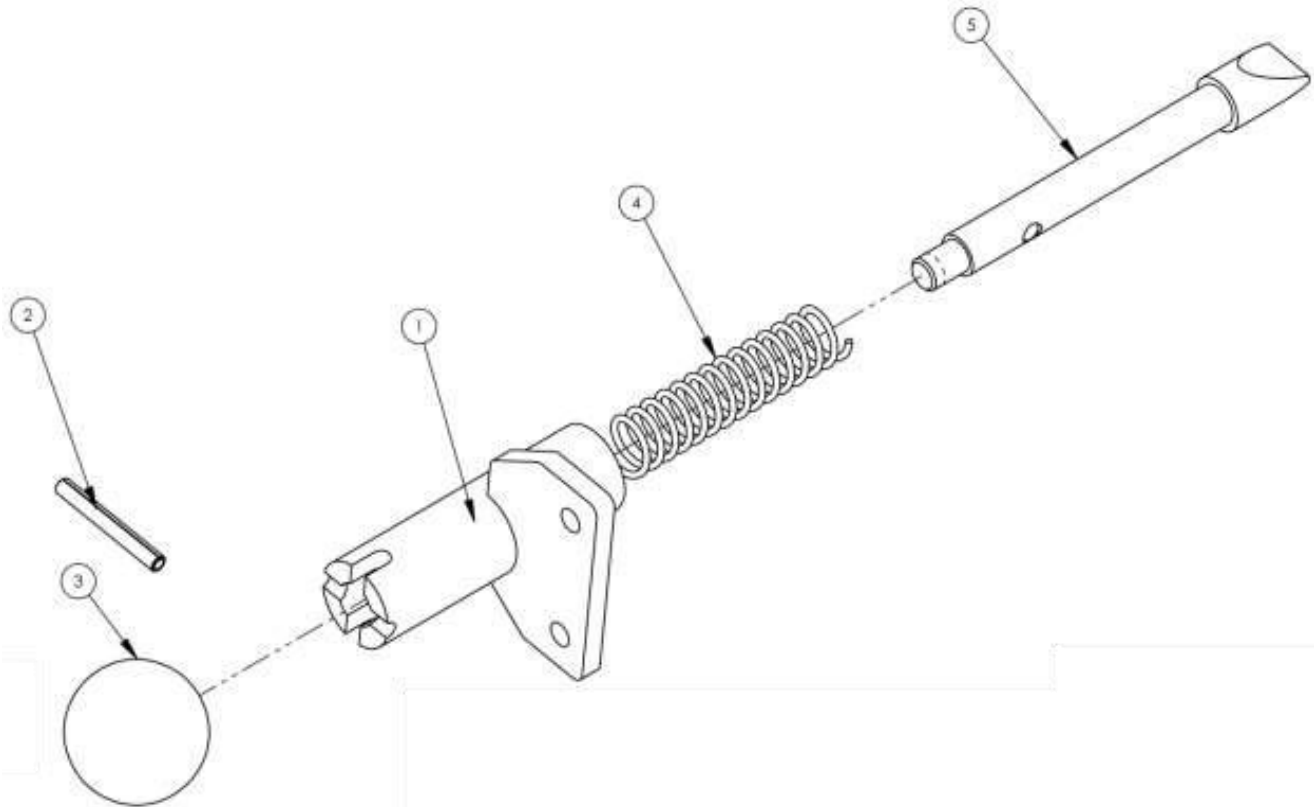

NO.	QTY	PART #	DESCRIPTION
1	1	13453801	SUPPORT GEAR LOCK ASSY.
2	1	IIS012X096	SPRING PIN, 3/16X1.5
3	1	MM61095K53	KNOB, BALL, 3/8-16 TAP
4	1	RRLC0742HJ	SPRING, COMP. .072X.66X3
5	1	13453804	MANDREL, GEAR LOCK

## Attachment Company (AAC) Statement of Warranty

### Manufactured Products

Atlanta Attachment Company warrants manufactured products to be free from defects in material and workmanship for a period of eight hundred (800) hours of operation or one hundred (100) days whichever comes first. Atlanta Attachment Company warrants all electrical components of the Serial Bus System to be free from defects in material or workmanship for a period of thirty six (36) months.

#### Terms and Conditions:

- AAC Limited Warranty becomes effective on the date of shipment.
- AAC Warranty claims may be made by telephone, letter, fax or e-mail. All verbal claims must be confirmed in writing.
- AAC reserves the right to require the return of all claimed defective parts with a completed warranty claim form.
- AAC will, at its option, repair or replace the defective machine and parts upon return to AAC.
- AAC reserves the right to make the final decision on all warranty coverage questions.
- AAC warranty periods as stated are for eight hundred (800) hours or one hundred (100) days whichever comes first.
- AAC guarantees satisfactory operation of the machines on the basis of generally accepted industry standards, contingent upon proper application, installation and maintenance.
- AAC Limited Warranty may not be changed or modified and is not subject to any other warranty expressed or implied by any other agent, dealer, or distributor unless approved in writing by AAC in advance of any claim being filed.

#### What Is Covered

- Electrical components that are not included within the Serial Bus System that fail due to defects in material or workmanship, which are manufactured by AAC are covered for a period of eight hundred (800) hours.
- Mechanical parts or components that fail due to defects in material or workmanship, which are manufactured by AAC.
- Purchased items (sewing heads, motors, etc.) will be covered by the manufacturers (OEM) warranty.
- AAC will assist in the procurement and handling of the manufacturers (OEM) claim.

#### What Is Not Covered

- Parts that fail due to improper usage, lack of proper maintenance, lubrication and/or modification.
- Damages caused by; improper freight handling, accidents, fire and issues resulting from unauthorized service and/or personnel, improper electrical, plumbing connections.
- Normal wear of machine and parts such as Conveyor belts, "O" rings, gauge parts, cutters, needles, etc.
- Machine adjustments related to sewing applications and/or general machine operation.
- Charges for field service.
- Loss of time, potential revenue, and/or profits.
- Personal injury and/or property damage resulting from the operation of this equipment.

## Declaración de Garantía

### Productos Manufacturados

Atlanta Attachment Company garantiza que los productos de fabricación son libres de defectos de material y de mano de obra durante un periodo de ochocientos (800) horas de operación o cien (100) días cual llegue primero. Atlanta Attachment Company garantiza que todos los componentes del Serial bus son libres de defectos de material y de mano de obra durante un periodo de treinta y seis (36) meses.

#### Términos y Condiciones:

- La Garantía Limitada de AAC entra en efecto el día de transporte.
- Reclamos de la Garantía de AAC pueden ser realizados por teléfono, carta, fax o correo electrónico. Todo reclamo verbal tiene que ser confirmado vía escrito.
- AAC reserva el derecho para exigir el retorno de cada pieza defectuosa con un formulario de reclamo de garantía.
- AAC va, según su criterio, reparar o reemplazar las máquinas o piezas defectuosas devueltas para AAC.
- AAC reserva el derecho para tomar la decisión final sobre toda cuestión de garantía.
- Las garantías de AAC tiene una validez de ochocientas (800) horas o cien (100) días cual llega primero.
- AAC garantiza la operación satisfactoria de sus máquinas en base de las normas aceptadas de la industria siempre y cuando se instale use y mantenga de forma apropiada.
- La garantía de AAC no puede ser cambiado o modificado y no está sujeto a cualquier otra garantía implicada por otro agente o distribuidor menos al menos que sea autorizado por AAC antes de cualquier reclamo.

#### Lo Que Está Garantizado

- Componentes eléctricos que no están incluidos dentro del sistema Serial Bus que fallen por defectos de materiales o de fabricación que han sido manufacturados por AAC son garantizados por un periodo de ochocientas (800) horas.
- Componentes mecánicos que fallen por defectos de materiales o de fabricación que han sido manufacturados por AAC son garantizados por un periodo de ochocientas (800) horas.
- Componentes comprados (Motores, Cabezales, ) son protegidos debajo de la garantía del fabricante.
- AAC asistirá con el manejo de todo reclamo de garantía bajo la garantía del fabricante.

#### Lo Que No Está Garantizado

- Falla de repuestos al raíz de uso incorrecto, falta de mantenimiento, lubricación o modificación.
- Daños ocurridos a raíz de mal transporte, accidentes, incendios o cualquier daño como resultado de servicio por personas no autorizados o instalaciones incorrectas de conexiones eléctricas o neumáticas.
- Desgaste normal de piezas como correas, anillos de goma, cuchillas, agujas, etc.
- Ajustes de la máquina en relación a las aplicaciones de costura y/o la operación en general de la máquina.
- Gastos de Reparaciones fuera de las instalaciones de AAC □ Pérdida de tiempo, ingresos potenciales, y/o ganancias.
- Daños personales y/o daños a la propiedad como resultado de la operación de este equipo.

**Notes:**

## 3.8. INDEX

### 1

1. General Security Instructions	60
<b>1. INSTALLATION</b>	14
1.4. Machine Identification Tag	16
1.7. Assembly	18

### 2

<b>2. OPERATION</b>	20
2.2. Preparation for Sewing	24

### 3

3.1. Lockout / Tag out Program	31
3.2. Mechanical Adjustments	32
3.3. Electrical Adjustments	44
3.4. Maintenance	55
3.5. Troubleshooting	61
3.6. High Mortality Kit.	63
3.7. Training	64

### 4

4. Tape Edge Folders	44
----------------------	----

### 6

6. Motors	49
-----------	----

### 7

7. Knee Pad	52
-------------	----

### 8

8. Electronic Clutch	54
----------------------	----

### A

Assembly Drawings & Parts Lists	88
---------------------------------	----

### I

Important Notices	9
Important Safety Instruction	5

### M

Maintenance	11
-------------	----



Atlanta Attachment Company Inc.  
362 Industrial Park Drive  
Lawrenceville, GA 30046 Phone: +1 (770)  
963-7369 [www.atlatt.com](http://www.atlatt.com)

**Printed in USA**  
Digital Version of this Manual Available at:  
[http://atlatt.com/tech\\_manuals.php](http://atlatt.com/tech_manuals.php)