

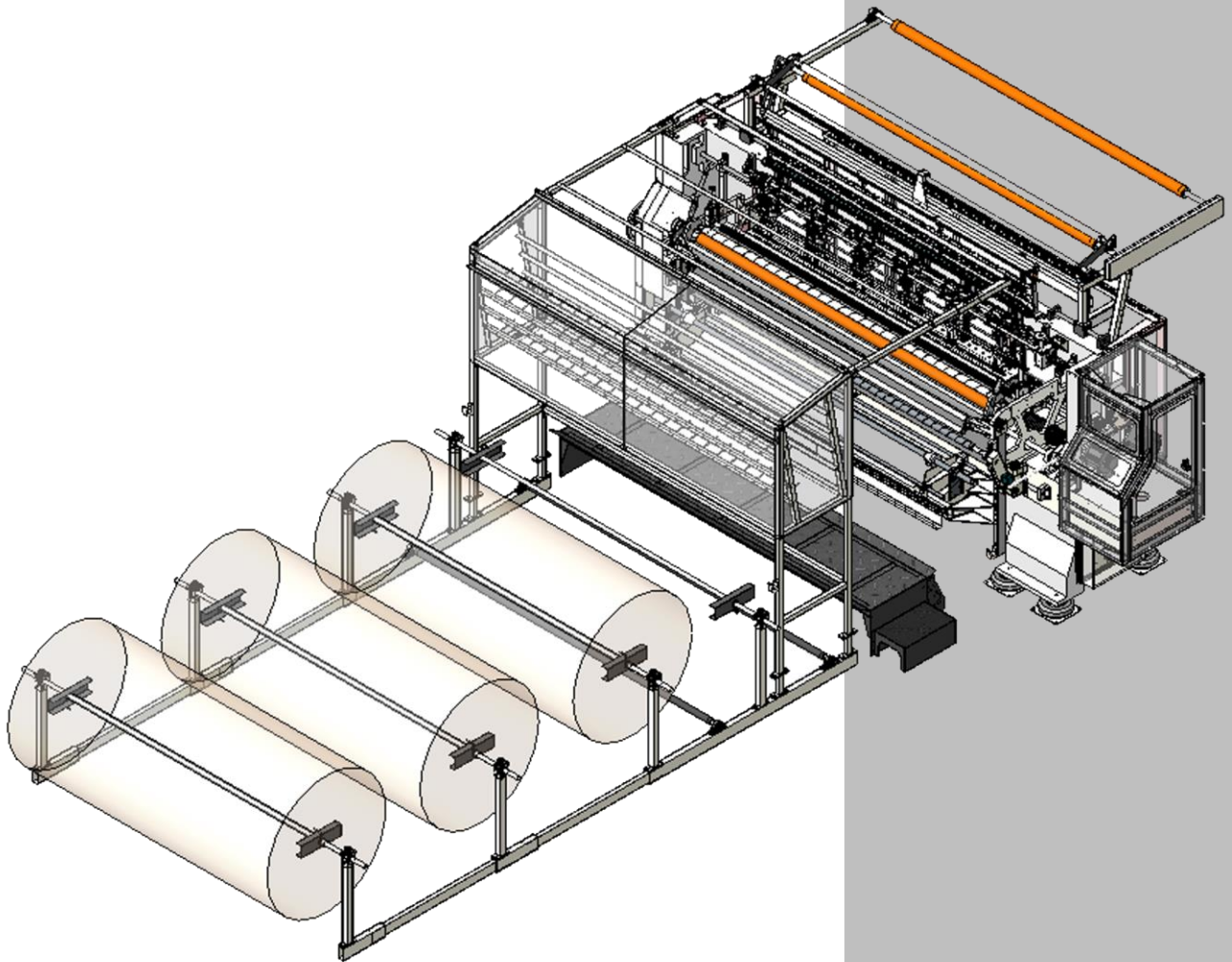

Model **1392D**

Revision 5.7 Updated Feb 22, 2018

Technical Manual & Parts Lists



Atlanta Attachment Company

362 Industrial Park Drive

Lawrenceville, GA 30046

770-963-7369 • www.atlatt.com

ATLANTA ATTACHMENT COMPANY, INC.

Confidential and Proprietary Information

The materials contained herein are confidential and proprietary information of Atlanta Attachment Company. In addition to any confidentiality and non-disclosure obligations that currently exist between you and Atlanta Attachment Company, your use of these materials serves as an acknowledgment of the confidential and proprietary nature of these materials and your duty not to make any unauthorized use or disclosure of these materials.

All materials contained herein are additionally protected by United States Copyright law and may not be used, disclosed, reproduced, distributed, published or sold without the express written consent of Atlanta Attachment Company, which consent may be withheld in Atlanta Attachment Company's sole discretion. You may not alter or remove any copyright, trademark or other notice from copies of these materials.

IMPORTANT
It is important to read and understand the information contained within this manual before attempting to operate the machine. Atlanta Attachment Co., Inc. shall not be held liable for damage resulting from misuse of the information presented within, and reserves the right to change the information contained within, without prior notification.

Contents

Important Safety Instruction	1
Liability	2
Safety Equipment on the Machines	3
Protective Eyewear	4
Important Notices.....	5
Maintenance	7
Repair	8
A Word to the End User.....	9
Safety Precautions.....	9
Setup Specifications.....	10
Power Requirements	11
Physical Specifications	11
Pressure Gauge Settings.....	11
Computer Connections.....	12
Quilter Setup & Training	13
Adjusting the Hand-Wheel	13
Adjusting the Eccentrics	13
Setting Eccentric Top Center	13
Fine tuning Eccentric Top Center	14
Adjust Pittman rod length.	14
Adjust Pittman rod length (Needle bar).....	14
Adjusting cams for presser-foot.....	15
Loosen up the needle-bar clamps.....	15
Turn hand-wheel to 180°.	15
Tighten needle lever on shaft.....	16
Set lowest needle position 1.....	16
Set lowest needle position 2.....	16
Set lowest needle position 3.....	17
Set lowest needle position 4.....	17
Set lowest presser-foot height.....	17
Lock down the presser-foot height.	18
Assemble springs on presser-foot.	18
Set front butterfly.....	18
Lock down the presser-foot height.	19
Assemble springs on presser-foot.	19
Operation.....	20

Definitions.....	20
Power Off.....	21
Main Run Screen.....	21
Machine Speed.....	22
Miscellaneous Information	23
Presser Foot adjustment procedure for 1392D.....	24
Foot Height	25
Pattern Selection	26
Size Adjustments	27
Pattern List.....	28
Pattern (Full View)	29
Needle Array.....	30
How-To Guide for Threading the 1392	31
From Thread Stand:	31
Looper Thread Routing:.....	35
Run History	39
Command Buttons	40
Pendant Operations	45
Utilities.....	47
Log Files	48
Copy Pattern Files.....	49
System Information.....	50
Security	51
Settings.....	52
Efficiency Statistics	57
Assembly Drawings & Parts Lists	58
11392D Quilter, Golden Eagle, HD.....	59
1389234 Panel Eye Cutter Assembly	60
1389353 Motor Guard Assembly.....	61
1389384 Left Guard Assembly.....	62
1389533 Front End Assembly	63
1389534 Bridge Assembly.....	64
1389566 Throat Plate Assembly.....	66
1389556 Base Assembly w/ Motors	67
1389238 Transfer Carriage Rail.....	68
1389697 Transfer Carriage Assembly	70
1392185 Rear Closure Assembly.....	72

1389740 Isolator Base Assembly.....	73
1392193 Operator Platform Assembly	74
1392195 Thread Stand Frame Assembly	76
1386740 Rear Feed Roll Dry Assembly	78
1392415 Lubrication Assembly	79
1392505 Remote Electrical Panel.....	80
1392744 Limit Switch Assembly.....	82
1392898 Y Axis Drive Idler Assembly	83
AAE1392 6 Station Solenoid Assembly.....	84
1393854 Filter Regulator Lockout Assembly.....	85
1392367 Backplane Assembly, Back Side	87
1388560 Front Guard Assembly.....	89
1392087 Front Tray Assembly	91
1393940 Regulator Valve Assembly	92
1392306 Roller Lift Assembly.....	93
1392448 Tension Roller Assembly.....	95
1392580 Bag Closing Mount Assembly	96
1392897 Pleat Prevention Assembly	97
1392978 Front Feed Assembly	98
1392935 Front Left Roller Sub-Assembly.....	99
1392936 Front Right Roller Sub-Assembly	100
1392937 Front Feed Roller Sub-Assembly.....	101
1392938 Left Sprocket Idler Assembly	102
1393922 Tensioner Assembly.....	103
1389023 Center Insert Mount Bearing	104
1389509 Presser Feet and Needle Bars.....	105
1392124 Needle Thread Mount Assembly	106
1393864 Foot Adjustment Assembly.....	107
1389199 Right Hand Bearing	108
1389200 Left Hand Bearing.....	109
1393986 Tie-Rod Assembly	110
1393994 LH Insert Mount Bearing Assembly.....	111
1388673 12in Leadscrew Drive	112
1389495 Retainer Drive Assembly.....	113
1389383 Oldham Offset Coupling.....	114
1392991 U-Joint, Retainer Assembly	115
1393998 Right Needle and Presser Foot Drive Assembly.....	117

Technical Manual & Parts Lists

1393999 Left Needle and Presser Foot Drive Assembly	119
1389815 Main Drive Shaft Assembly	121
1392070 Roll Servo Drive Assembly	122
1392071 Carriage Servo Drive Assembly	123
1392082 Needle Bar Drive Assembly	124
1392125 Rear Thread Tension Assembly	125
1392196 Take-up Looper Assembly	126
1389575 Torque Limit Assembly	127
1392230 Guard Assembly	128
1389183 Regulator Assembly	129
1392366 Front Side Backplane Assembly	131
1392545 Material Tension Rack	132
1392972 LH Small Tension Clamp Assembly	133
1392973 RH Small Tension Clamp Assembly	134
1392959 Closer Assembly	135
1392151 B Pole Assembly	136
1389274 Dual Thread Break Detector Assembly	137
1393875 Footlift Adjusting Knob Assembly	139
1392291 Thread Tension Guide Assembly	140
1392304 Bearing Butterfly Assembly	141
1392846 Butterfly Drive Assembly	142
1389024 Large Eccentric Assembly	143
1389025 Small Eccentric Assembly	144
1388222 Front Linear Slide, 35MM	145
1388227 Right Linear Slide, 35MM	146
1392329 Looper Holder, LH	147
1392347 Looper Holder Assembly, RH	148
1392364 Control Cabinet Assembly	151
1392C-PD Pneumatic Diagram	152
1392-WD1 Cabinet Wiring Diagram	153
1392-WD2 Quilter Panel Wiring Diagram	154

Important Safety Instruction



This part of the Instruction Material is provided for the safe use of your equipment. It contains important information to help work safely with the unit and describes the dangers inherent in machinery. Some of these dangers are obvious, while others are less evident.

Mandatory Information

All persons operating and/or working on the 1392D Golden Eagle Quilter, HD should read and understand all parts of the Safety Instructions. This applies, in particular, for persons who only operate and/or work on the unit occasionally (e.g. for maintenance and repair). Persons who have difficulty reading must receive particularly thorough instruction.

Scope of the Instruction Material

- The Instruction Material comprises:
- Safety information
- Operator Instructions
- Electrical and Pneumatic diagrams

And may also include;

- A list of recommended spare parts
- Instruction Manual(s) for components made by other manufacturers
- The layout and installation diagram containing information for installation

Intended Use

Our machines are designed and built in line with the state of the art and the accepted safety rules. However, all machines may endanger the life and limb of their users and/or third parties and be damaged or cause damage to other property, particularly if they are operated incorrectly or used for purposes other than those specified in the Instruction Manual.

Exclusion of Misuse



Non-conforming uses include, for example, using the equipment for something other than it was designed for, as well as operation without duly installed safety equipment. The risk rests exclusively with the end user.

Conforming use of the machine includes compliance with the technical data, information and regulations in all parts of the complete Instruction Material, as well as compliance with the maintenance regulations. All local safety and accident prevention regulations must also be observed.

Liability

The machine should only be operated when in perfect working order, with due regard for safety and the potential dangers, as well as in accordance with the Instruction Material. Faults and malfunctions capable of impairing safety should be remedied immediately. We cannot accept any liability for personal injury or property damage due to operator errors or non-compliance with the safety instructions contained in this booklet. The risk rests exclusively with the end user.

The Instruction Material should always be kept near the machine so that it is accessible to all concerned.

The local, general, statutory and other binding regulations on accident prevention and environmental protection must also be observed in addition to the Instruction Material. The operating staff must be instructed accordingly. This obligation also includes the handling of dangerous substances and provision/use of personal protective equipment.

The Instruction Material should be supplemented by instructions, including supervisory and notification duties with due regard for special operational features, such as the organization of work, work sequences, the personnel deployed, etc.

The personnel's awareness of the dangers and compliance with the safety regulations should be checked at irregular intervals.

Choice and Qualification of Personnel

Ensure that work on the machine is only carried out by reliable persons who have been appropriately trained for such work - either within the company, by our field staff or at our office - and who have not only been duly appointed and authorized, but are also fully familiar with the local regulations. Work on the machine should only be carried out by skilled personnel, under the management and supervision of a duly qualified engineer.

This not only applies when the machine is used for production, but also for special work associated with its operation (start-up and maintenance), especially when it concerns work on the hydraulic or electrical systems, as well as on the software/serial bus system.

Training

Everyone working on or with the machine should be duly trained and informed with regard to correct use of the safety equipment, the foreseeable dangers which may arise during operation of the machine and the safety precautions to be taken. In addition, the personnel should be instructed to check all safety mechanisms at regular intervals.

Responsibilities

Clearly define exactly who is responsible for operating, setting-up, servicing and repairing the machine. Define the responsibilities of the machine operator and authorize him to refuse any instructions by third parties if they run contrary to the machine's safety. This applies in particular for the operators of machines linked to other equipment. Persons receiving training of any kind may only work on or with the machine under the constant supervision of an experienced operator. Note the minimum age limits permitted by law.

A Word to the Operator

The greatest danger inherent in our machines: is that of fingers, hands or loose clothing being drawn into a machine by live, coasting or rotating tools or assemblies or of being cut by sharp tools or burned by hot elements.

ALWAYS BE CONSCIOUS OF THESE DANGERS!

Safety Equipment on the Machines



All machines are delivered with safety equipment, which shall not be removed or bypassed during operation.

The correct functioning of safety equipment on machines and systems should be checked every day and before every new shift starts, after maintenance and repair work, when starting up for the first time and when restarting (e.g. after prolonged shutdowns).

If safety equipment has to be dismantled for setting-up, maintenance or repair work, such safety equipment shall be replaced and checked immediately upon completing the maintenance or repair work. All protective mechanisms shall be fitted and fully operational whenever the machine is at a standstill or if it has been shut down for a longer period of time.

Damage

If any changes capable of impairing safety are observed in the machine or its mode of operation, such as malfunctions, faults or changes in the machine or tools, appropriate steps must be taken immediately, the machine switched off and a proper lockout tagout procedure followed. The machine should be examined for obvious damage and defects at least once per shift. Damage found shall be immediately remedied by a duly authorized person before resuming operation of machine.

The machine should only be operated when in perfect working order and when all protective mechanisms and safety equipment, such as detachable protective mechanisms, emergency STOP systems, etc. are in place and operational.

Faults or Errors

The machine must be switched off and all moving or rotating parts allowed to come to a standstill and secured against accidental restart before starting to remedy any faults or errors.

Signs on the Machine

Safety and danger signs on the machine should be observed and checked at regular intervals to ensure that they are complete and undamaged. They should be clearly visible and legible at all times.

Clothing, Jewelry, Protective Equipment

Long loose hair, loose-fitting clothes, gloves and jewelry, including rings, should be avoided in order to avoid injuries due to being caught, drawn in and wound up inside the machine.

Protective Eyewear

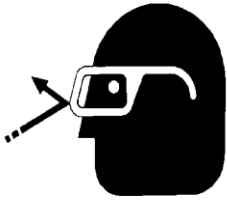

Protective eyewear that has been tested by the local authorities should be worn whenever there is a possibility of loose or flying objects or particles such as when cleaning the machine with compressed air.

Tools

Always count the number of tools in your possession before starting work on the machine. This will allow you to check that no tools have been left behind inside the machine. Never leave a tool in the machine while working.

Oils, Lubricants, Chemicals

Note the applicable safety regulations for the product used.

No Smoking, Fire, Explosion Hazard

Smoking and open flame (e.g. welding work) should be prohibited in the production area due to the risk of fire and explosions.

Workplace

A clear working area without any obstructions whatsoever is essential for safe operation of the machine. The floor should be level and clean, without any waste.

The workplace should be well lit, either by the general lighting or by local lights.

Emergency STOP

The emergency STOP buttons bring all machine movements to a standstill. Make sure you know exactly where they are located and how they work. Try them out. Always ensure easy access to the nearest emergency STOP button while working on the machine.

First Aid

1. Keep calm even when injured.
2. Clear the operator from the danger zone. The decision of what to do and whether to seek additional assistance rests entirely with you, particularly if someone has been trapped.
3. Give First Aid. Special courses are offered by such organizations as the employers' liability insurance association. Your colleagues should be able to rely on you and vice versa.
4. Call an ambulance. Do you know the telephone numbers for the ambulance service, police and fire service?

Important Notices

Reporting and Fighting Fires

Read the instructions posted in the factory with regard to reporting fires and the emergency exits. Make sure you know exactly where the fire extinguishers and sprinkler systems are located and how they are operated. Pass on the corresponding information to the firemen when they arrive. Ensure there are enough signs to avoid fire hazards.

The following fire extinguishers may be used:

- Dry powder extinguishers, ABC fire-extinguishing powder.
- Carbon dioxide fire extinguishers to DIN 14461 for electronic components. Great care must be exercised when using carbon dioxide fire extinguishers in confined, badly ventilated rooms (see DIN 14406 and 14270).

Isolate the machine from the power supply if a fire breaks out. Do not use water on burning electrical parts until it is absolutely certain that they have been completely disconnected from the power supply. Burning oils, lubricants, plastics and coatings on the machine can give off gases and vapors that may be harmful to your health.

A qualified person should be consulted to repair the damage after a fire.

Electrical Power Supply

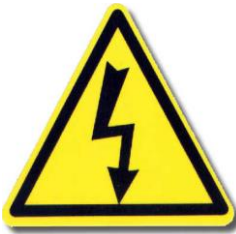

Before undertaking any maintenance or repair work on the machine, switch off the electrical power to the machine at the main source and secure it with a padlock so that it cannot be switched on again without authorization.

In practice, this may mean that the technician, electrician and operator all attach their own padlock to the master switch simultaneously so that they can carry out their work safely. Locking extension plates should be available for multiple locks if required. The primary purpose for a lockout/tagout procedure is to protect workers from injury caused by unexpected energizing or start-up of equipment.

Energy sources (electrical/pneumatic/hydraulic, etc.) for the equipment shall be turned off or disconnected and the switches locked or labeled with a warning tag. It is the responsibility of the employer to establish control procedures. Follow lockout/tagout procedures before, setup and/or any service or maintenance work is performed, including lubrication, cleaning or clearance of jams.

Caution: The machine is still not completely de-energized even when the master switch is off.

- Electricity - The machine is always isolated from the electrical power supply whenever the master switch has been switched off. However, this does not apply for the power supply in the control cabinet, nor for equipment that does not draw its power via the master switch.
- Pneumatic / hydraulic energy - Almost all our machines carry compressed air. In addition to switching off the master switch, the air supply must also be disconnected and the machine checked to ensure it is depressurized before starting any work on the machine; otherwise the machine may execute uncontrolled movements.

- Kinetic energy - Note that some motors or spindles, for example, may continue to run or coast run on after being switched off.
- Potential energy - Individual assemblies may need to be secured if necessary for repair work.

Delivery of the Machine/Packaging

Note any markings on the packaging, such as weights, lifting points and special information. Avoid temperature fluctuations. Condensation may damage the machine.

Transport Damage

The packaging and machine must immediately be examined for signs of damage in transit. Such damage must be reported to the shipper/transporter within the applicable time limits. Contact Atlanta Attachment Company and/or your transport insurer immediately, if signs of damage are visible. Never operate a damaged machine.

Interim Storage

If the machine has to be stored temporarily, it must be oiled or greased and stored in a dry place where it is protected from the weather in order to avoid damage. A corrosion-inhibiting coating should be applied if the machine has to be stored for a longer period of time and additional precautions taken to avoid corrosion.

Transporting the Machine

Disconnect the machine from all external connections and secure any loose assemblies or parts. Never step under a suspended load. When transporting the machine or assemblies in a crate, ensure that the ropes or arms of a forklift truck are positioned as close to the edge of the crate as possible. The center of gravity is not necessarily in the middle of the crate. Note the accident prevention regulations, safety instructions and local regulations governing transport of the machine and its assemblies.

Only use suitable transport vehicles, hoisting gear and load suspension devices that are in perfect working order and of adequate carrying capacity. Transport should only be entrusted to duly qualified personnel.

Never allow the straps to rest against the machine enclosure and never push or pull sensitive parts of the machine. Ensure that the load is always properly secured. Before or immediately after loading the machine, secure it properly and affix corresponding warnings.

All transport guards and lifting devices must be removed before the machine is started up again. Any parts that are to be removed for transport must be carefully refitted and secured before the machine is started up again.

Workplace Environment

Our machines are designed for use in enclosed rooms: Permissible ambient temperature approx. 5 - 40 °C (40 - 104 °F). Malfunctions of the control systems and uncontrolled machine movements may occur at temperatures outside this range.

Protect against climatic influences, such as electrostatic charges, lightning strikes, hail, storm damage, high humidity, salinity of the air in coastal regions.

Protect against influences from the surroundings: no structure-borne vibrations, no grinding dust, or chemical vapors.

Protect against unauthorized access.

Ensure that the machine and accessories are set up in a stable position.

Ensure easy access for operation and maintenance (Instruction Manual and layout diagram); also verify that the floor is strong enough to carry the weight of the machine.

Local Regulations

Particular attention must be paid to local and statutory regulations, etc. when installing machines and the plant (e.g. with regard to the specified escape routes). Note the safety zones in relation to adjacent machines.

Maintenance

General Safety Instructions

The machine shall be switched off, come to a standstill and be secured so that it cannot be switched on again inadvertently before starting any maintenance work whatsoever. Use proper lockout/tagout procedures to secure the machine against inadvertent startup.

Remove any oil, grease, dirt and waste from the machine, particularly from the connections and screws, when starting the maintenance and/or repair work. Do not use any corrosive-cleaning agents. Use lint-free rags.

Retighten all screw connections that have to be loosened for the maintenance and repair work. Any safety mechanisms that have to be dismantled for setting-up, maintenance or repair purposes must be refitted and checked immediately after completing the work.

Maintenance, Care, Adjustment

The activities and intervals specified in the Instruction Manual for carrying out adjustments, maintenance and inspections must be observed and parts replaced as specified.

All hydraulic and pneumatic lines should be examined for leaks, loose connections, rubbing and damage whenever the machine is serviced. Any defects found must be remedied immediately.

Waste, Disassembly, Disposal

Waste products should be cleared from the machine as soon as possible as not to create a fire hazard. Ensure that fuels and operating lubricants, as well as replacement parts are disposed of in a safe and ecologically acceptable manner. Note the local regulations on pollution control.

When scrapping (disassembling) the machine and its assemblies, ensure that these materials are disposed of safely. Either commission a specialist company familiar with the local regulations or note the local regulations when disposing of these materials yourself. Materials should be sorted properly.

Repair

Replacement Parts

We cannot accept any liability whatsoever for damage due to the use of parts made by other manufacturers or due to unqualified repair or modification of the machine.

Repair, Electrical

The power supply must be switched off (master switch off) and secured so that it cannot be switched on again inadvertently before starting any work on live parts.

Those parts of the machine and plant on which inspection, maintenance or repair work is to be carried out must be isolated from the power supply, if specified. The isolated parts must first be checked to determine that they are truly de-energized before being grounded and short-circuited. Adjacent live parts must also be isolated.

The protective measures implemented (e.g. grounding resistance) must be tested before restarting the machine after all assembly or repair work on electric parts.

Signal generators (limit switches) and other electrical parts on the safety mechanisms must not be removed or bypassed. Only use original fuses or circuit overloads with the specified current rating. The machine must be switched off immediately if a fault develops in the electrical power supply.

The electrical equipment of our machines must be checked at regular intervals and any defects found must be remedied immediately.

If it is necessary to carry out work on live parts, a second person should be on hand to operate the emergency OFF switch or master switch with voltage release in the event of an emergency. The working area should be cordoned off and marked by a warning sign. Only use electrically insulated tools.

Ventilation/Hazardous Gases

It is the end users responsibility to ensure adequate ventilation is provided to exhaust any and all noxious or hazardous gases that may be present in the working environment.

Hydraulic and Pneumatic Systems

Work on hydraulic or pneumatic equipment shall only be carried out by persons with training, knowledge and experience of hydraulic systems. Pressure lines shall be depressurized before starting any repair work.

General Liability

Liability for machine damage and personal injury is extinguished completely if any unauthorized conversions or modifications are undertaken. The machine must not be modified, enlarged or converted in any way capable of affecting safety without the manufacturer's prior approval.

Starting Machine Movements

Read the Instruction Manual carefully to establish which keys and functions start machine movements.

A Word to the End User

The end user has sole responsibility to enforce the use of safety procedures and guards on the machine. Any other safety devices or procedures due to local regulations should be should be retrofitted in accordance to these regulations and/or the EC Directive on the safety of machines.

Operator's position must always be readily accessible. Escape routes must always be kept clear and safety areas should be identified.

Safety Precautions

Safety should be a constant concern for everyone. Always be careful when working with this equipment. While normal safety precautions were taken in the design and manufacture of this equipment, there are some potential safety hazards.

Everyone involved with the operation and maintenance of this equipment should read and follow the instructions in this manual.

Operate the equipment only as stated in this manual. Incorrect use could cause damage to the equipment or personal injury.

It is the owner's responsibility to make certain that the operator reads and understands this manual before operating this equipment. It is also the owner's responsibility to make certain that the operator is a qualified and physically able individual, properly trained in the operation of this equipment.

Specific safety warning decals are located on the equipment near the immediate areas of potential hazards. These decals should not be removed or obliterated. Replace them if they become non-readable.

- ALWAYS keep safety shields and covers in place, except for servicing.
- ALWAYS operate equipment in daylight or with adequate working lights.
- Follow daily and weekly checklists, making sure hoses are tightly secured and bolts are tightened.
- ALWAYS watch and avoid holes or deep depressions.
- ALWAYS wear adequate eye protection when servicing the hydraulic system and battery.
- NEVER operate a poorly maintained machine.
- NEVER allow persons to operate this machine without proper instruction.
- NEVER put hands or feet under any part of the machine while it is running.
- NEVER attempt to make any adjustments or repairs to the machine while running. Repairs or maintenance should be performed by trained personnel only.
- NEVER work under the machine unless it is safely supported with stands, blocks or a hoist and blocks.
- NEVER touch hot parts of machine.

Setup Specifications

	2" Stroke (Gauge)
1. NEEDLE BAR DRIVE LEVER (SHOULDER TO SHAFT C/L)	35 MM ("A")
2. NEEDLE BAR PITMAN ROD... (18.1")	460MM.....
3. NEEDLE BAR TRAVEL (2.00")	51 MM.....
4. PRESSER FOOT PITTMAN ROD (22.2")	565MM.....
5. NEEDLE BAR (MODIFIED) HEIGHT ABOVE T/P @ BDC...180°	37 MM ("B")
6. POINT OF NEEDLE BELOW NEEDLE PLATE @ BDC...180°	28 MM ("D")
7. POINT OF NEEDLE BELOW NEEDLE PLATE @ TAKE TIME...232°	19 MM ("C")
8. TIMING	NEEDLE BAR DOWN = LOOPERS BACK.....
9. LOOPER PITMAN ROD LENGTH	85 MM.....
10. LOOPER DRIVE ARM SPACER OD TO AXIS CENTER	47 MM.....
11. RETAINERS REARWARD	64°
12. REAR RETAINER BAR BACK TO BACK OF NEEDLE PLATE @ 64°	89MM.....
13. POINT OF RETAINER TO NEEDLE @ 154°	1-2 MM.....
14. LOOP TAKE TIME (PT OF LPR @ FT OF NDL)	232°
15. LOOPER TRAVEL	29 MM.....
16. REAR BUTTERFLY ECCENTRIC FORWARD	148°
17. BUTTERFLY STROKE	RODEND CENTERED IN SLOT ("E")
18. BUTTERFLY PITMAN ROD LENGTH	265MM.....
19. REAR BUTTERFLY ROD TO FRAME @ LOWEST POSITION (148°)	38 MM ("F")
20. REAR BUTTERFLY ROD TO FRAME @ HIGHEST POSITION (328°)	58 MM.....
21. FRONT BUTTERFLY TIMING	LEVEL @ 90°.....
22. NEEDLE THREAD TAKE-UP ROD	DOWN 15°.....
(LOWER ROD FOR THICKER MAT'L)	
23. PRESSER FOOT HEIGHT, NDL DOWN @ LOWEST SETTING	3 MM.....
24. PRESSER FOOT CAMS	LEVEL @ 0 DEG.....
25. LOOPER TIMING ADJUSTMENT	LOW MOVING FORWARD?= ADV ECCENTRIC.....

Power Requirements

Volts	208-240 VDC
Amps	40 Amps / 3 Phase
Air Pressure	90 PSI

Physical Specifications

Overall Dimensions:	15' X 25'
Weight:	25000 lbs.
Recommended Needle:	SN794FR-180
Stitch Length:	4-8 SPI

Pressure Gauge Settings

Main Pressure Regulator:	70 PSI
Pressure Roller Regulator:	50-80 PSI
Dancer Bar Regulator:	5-20 PSI

Computer Connections

The 1392D control panel may require the unpacking and setup of the computer. The following pictures show front and rear connections for hooking up the control system computer.



PLEASE NOTE: DO NOT REMOVE THE TWO GREEN USB SECURITY DONGLES FROM THE COMPUTER. IF ANY OF THESE DONGLES ARE REMOVED, THE EZ-QUILTER SOFTWARE WILL NOT LONGER FUNCTION.

ONE DONGLE IS FOR THE EZ PATTERN DESIGN SOFTWARE (LABELED "P") AND THE OTHER IS FOR THE EZ QUILT SOFTWARE (LABELED "Q").

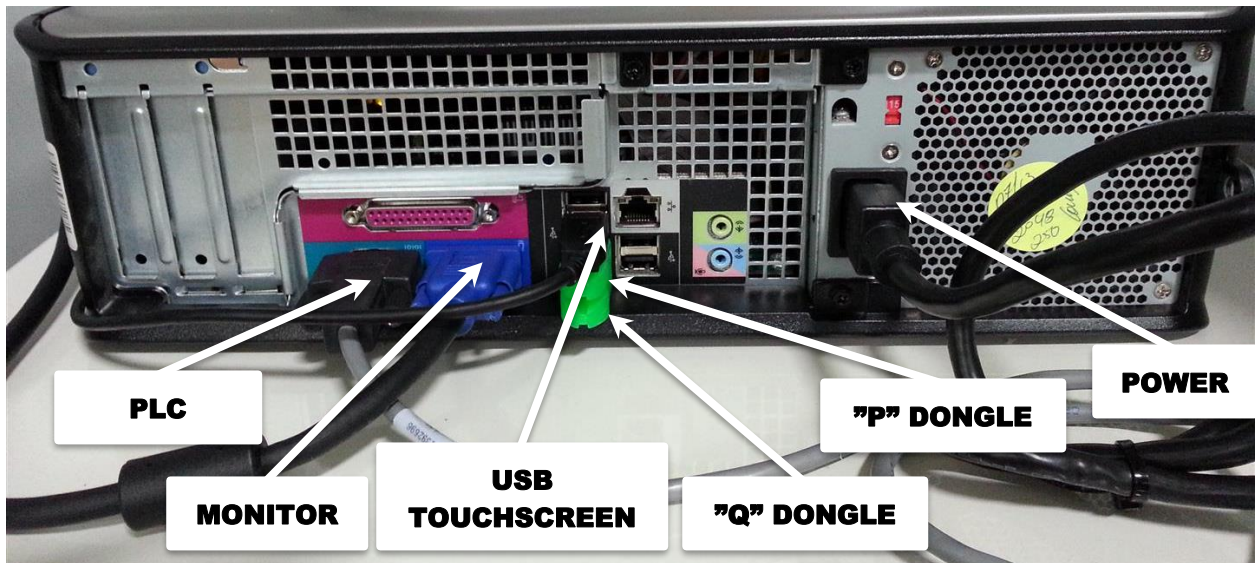

BACK SIDE COMPUTER CONNECTIONS

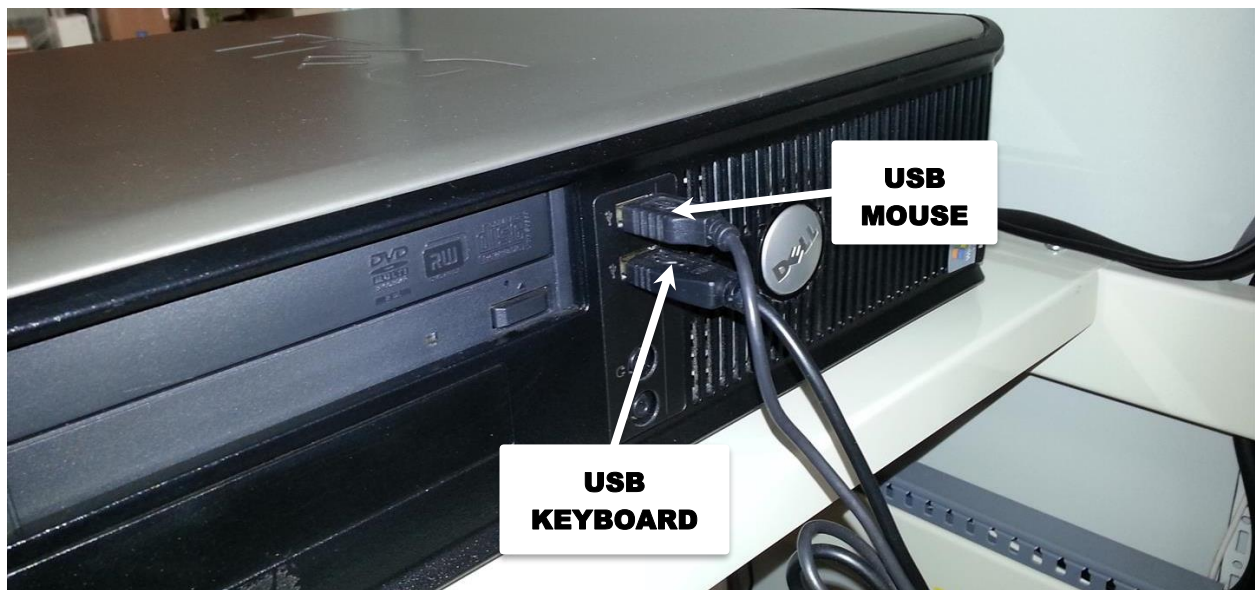

FRONT SIDE COMPUTER CONNECTIONS

Quilter Setup & Training

Adjusting the Hand-Wheel

- Tighten hand-wheel bolt
- Move hand-wheel to Zero degrees
- Clamp Main Shaft, To Prevent Movement

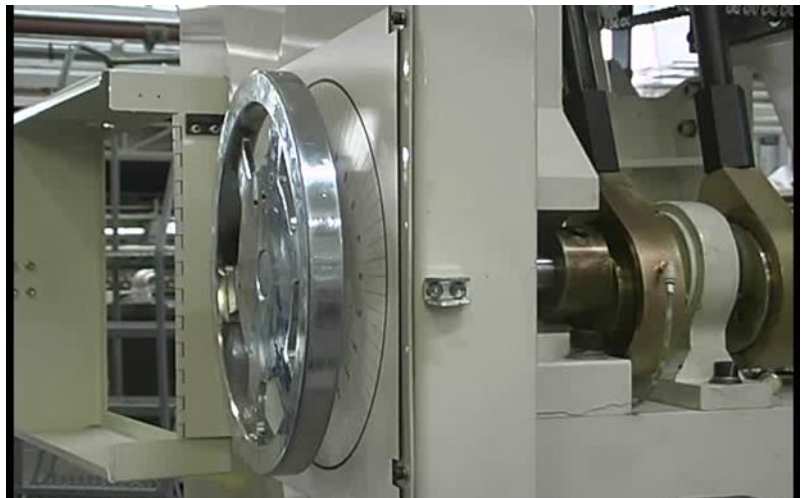

Adjusting the Eccentrics

- Move presser foot eccentric to the highest position
- Tighten one bolt of eccentric



Setting Eccentric Top Center

Place dial indicator magnetic base on flat surface

Place dial indicator tip on top of presser foot rod end bearing

Rotate presser foot eccentric until the pointer of the dial indicator doesn't move anymore.

Tighten one bolt of the eccentric

To check turn hand-wheel between 345° and 15°. The dial indicator needs to point at the same number at 345° and 15°



Fine tuning Eccentric Top Center

- To check turn hand-wheel between 345° and 15° . The dial indicator needs to point at the same number at 345° and 15°
- Change eccentric position
- Check the top center by moving hand wheel between 345° and 15°



Adjust Pittman rod length.

- Loosen up the 2 nuts
- Turn the rod until you have the right length.
- Tighten the 2 nuts
- Check the final length (570mm)



Adjust Pittman rod length (Needle bar).

- Do the same as the presser-foot Pittman-rod with the Pitman-rod for the needle bar
- Find “top dead center”
- Test “top dead center” with turning hand-wheel from 245° up to 15°
- Length of Pitman-rod need to be 460mm
- Repeat this step on the other side of the machine so the Pitman-rod for the presser-foot and the needle bar are the same on both side of the machine

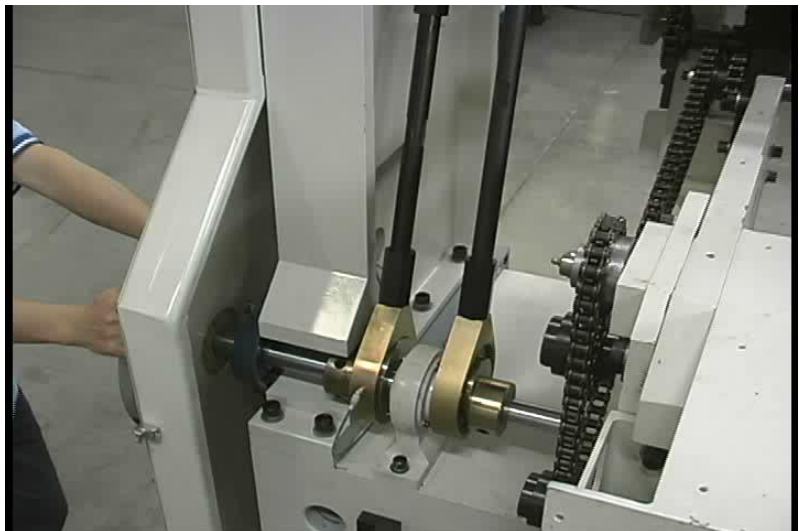

Adjusting cams for presser-foot.

- Turn the hand-wheel to 0°
- Push needle bar clamps down then tighten the bolts
- Bring all the cams down so they hit the cam-follower then tighten the bolts
- Turn the shaft up so all the cams are level then tighten the bolts
- Tighten the levers on both sides

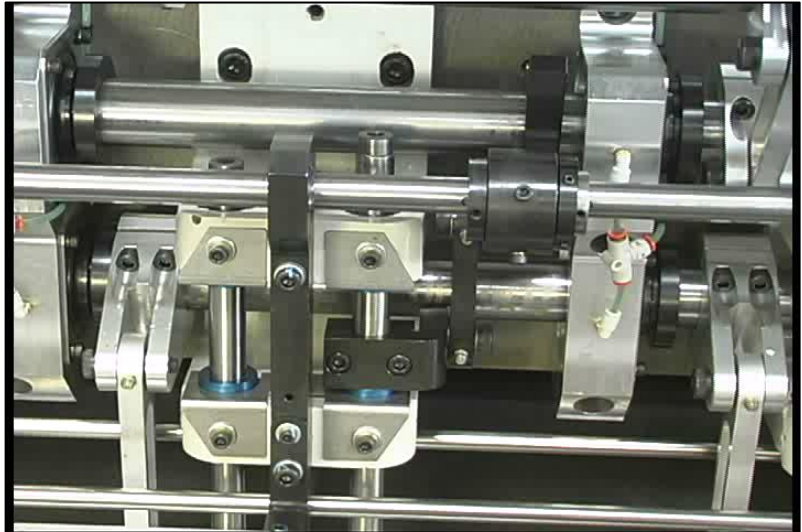

Loosen up the needle-bar clamps.

- **After adjusting the** cams and followers loosen up the clamps of the needle bars.

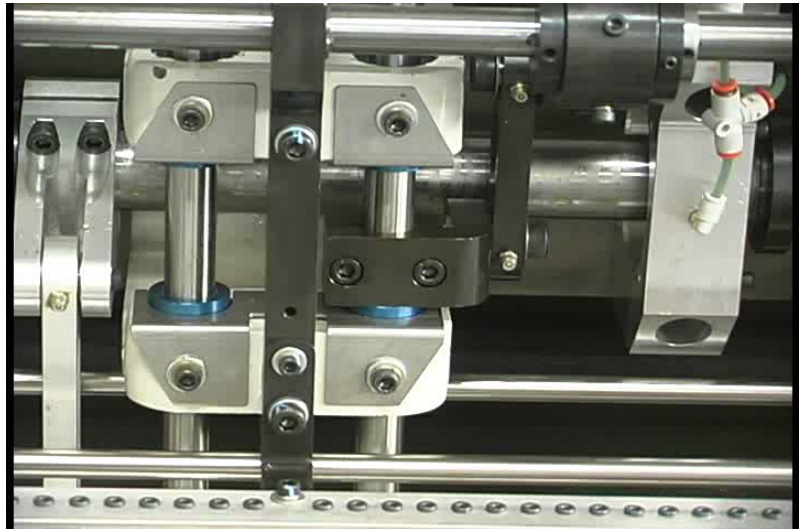

Turn hand-wheel to 180°.



Tighten needle lever on shaft.

- Tighten the 2 needle lever on the shaft. (6 bolts every lever)

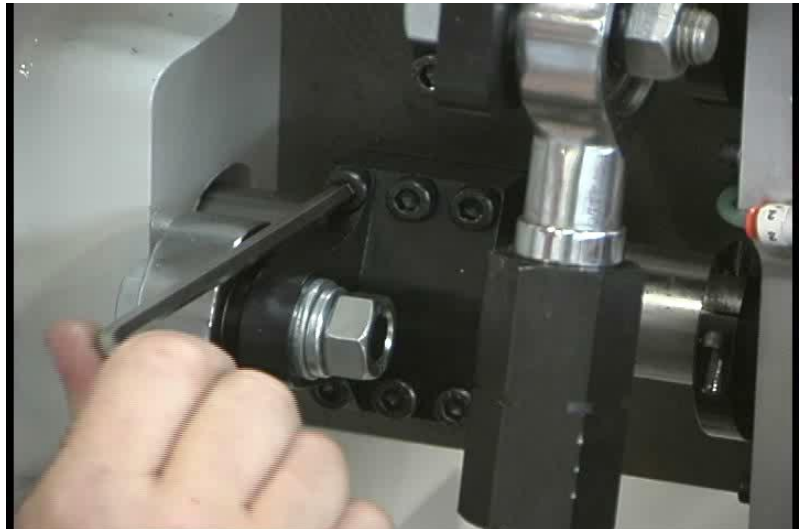

Set lowest needle position 1.

- If not already so, put the 3mm spacer under the presser-foot.
- Place the 14.3mm spacers between the presser-foot and the needle bars



Set lowest needle position 2.

- The tip of the needle should be 28mm under the throat-plate when the machine is at 180°
- We can test this with the special gauge

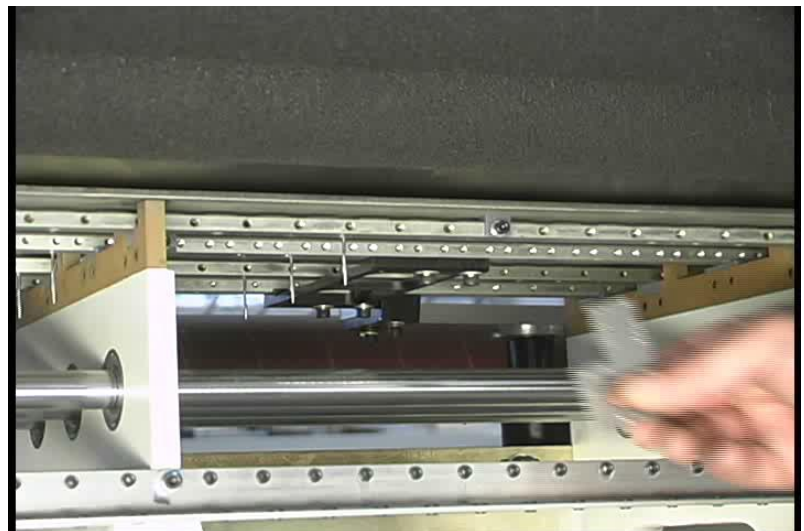

Set lowest needle position 3.

- Use the presser-foot adjustment to set the right needle height.
- Check the needle height after foot-lift adjustment.



Set lowest needle position 4.

- When the needle height is 28mm under the throat-plate tighten bolts of the link between needle-bar and shaft.

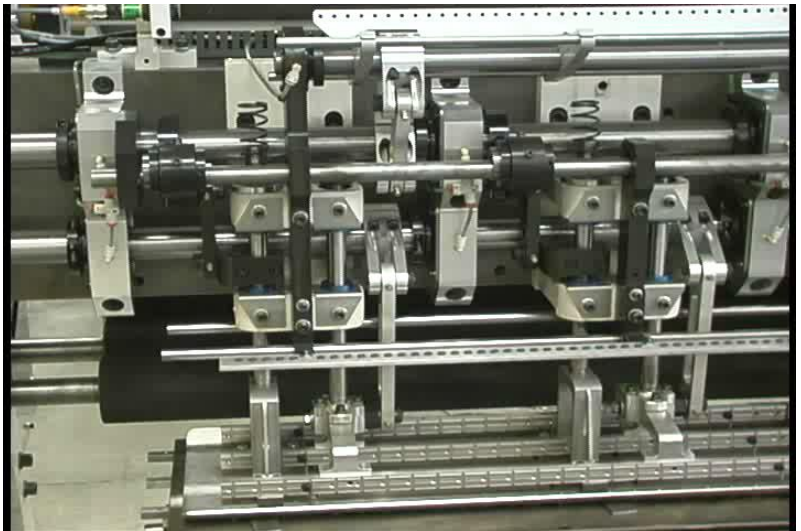

Set lowest presser-foot height.

- Raise the foot up with spacers of 3mm thick.
- Adjust the foot to its lowest position (use little hand wheel)
- The foot is at his lowest position when the key of the shaft is facing out.



Lock down the presser-foot height.

- Use bolt to extent presser-foot bar
- Press the presser-foot down on the 3mm spacers
- Lift up clamp on presser-foot bar so the cam-followers or op against the cams
- Tighten bolts from clamp (make sure the clams are not twisted)

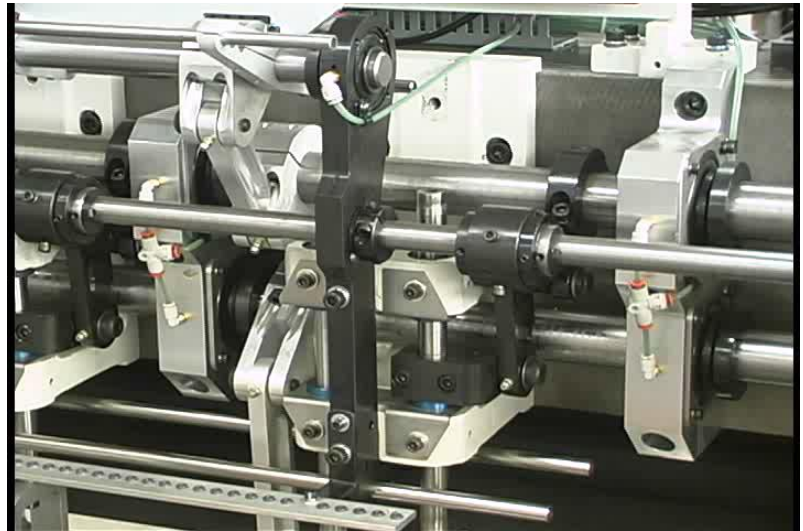

Assemble springs on presser-foot.

- Place spring disk
- Place spring
- Place spring cap
- Use special tool to compress the spring and tighten spring with bolt.
- Repeat this with all 8 presser bars

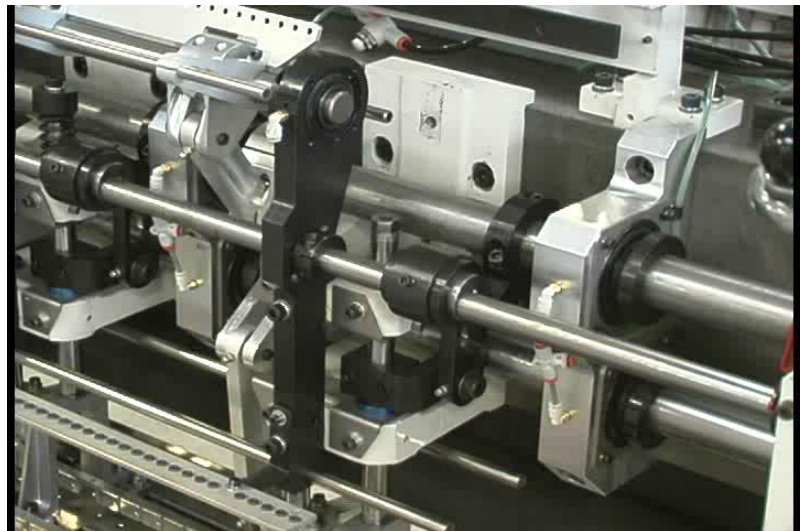

Set front butterfly.

- Turn hand-wheel to 90°
- Level the butterfly
- Tighten the 3 links from shaft to butterfly shaft
- Turn the machine with the hand-wheel. The machine should turn smoothly



Lock down the presser-foot height.

- Use bolt to extent presser-foot bar
- Press the presser-foot down on the 3mm spacers
- Lift up clamp on presser-foot bar so the cam-followers or op against the cams
- Tighten bolts from clamp (make sure the clams are not twisted)

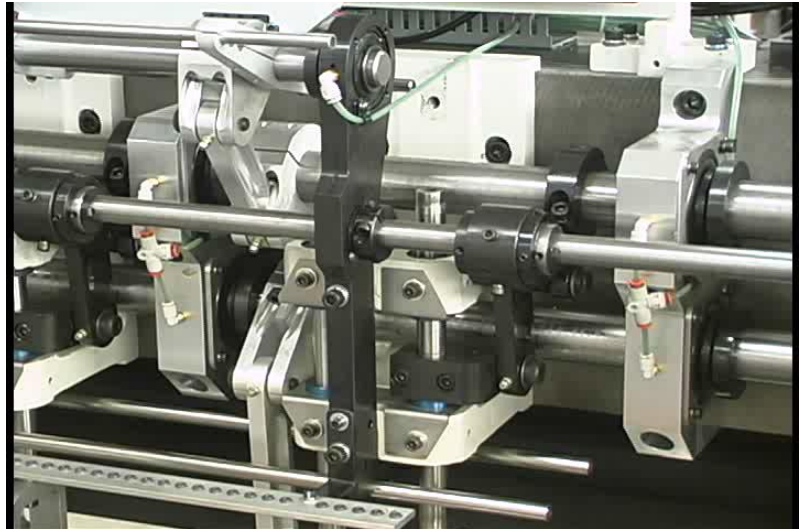

Assemble springs on presser-foot.

- Place spring disk
- Place spring
- Place spring cap
- Use special tool to compress the spring and tighten spring with bolt.
- Repeat this with all 8 presser bars

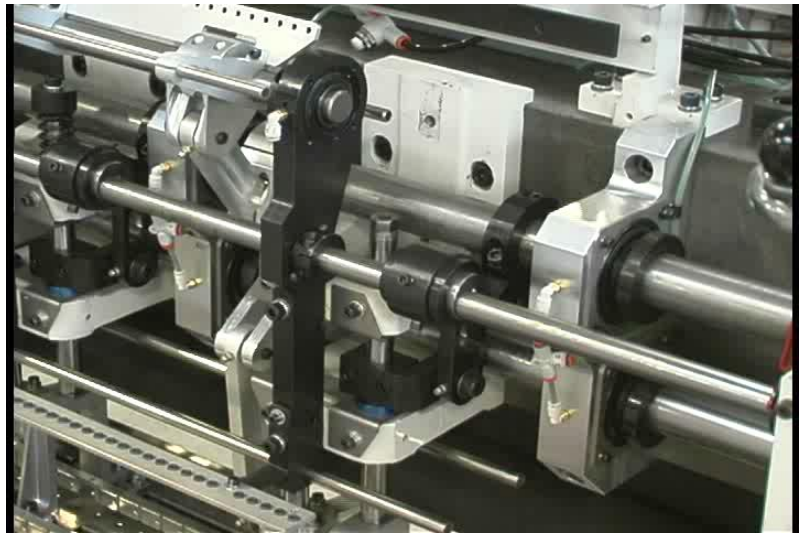

Operation

Definitions

Machine Axis -The machine has three Servo motors. One for each Axis of movement.

X-Axis is the left and right movement of the carriage.

Y-Axis is the Roller movement or front to back.

Z-Axis is the Needle up and down movement.

Machine Homing - Homing (or Home-Out) is the process of moving the X and Z axis to a known physical location in order to establish a zero point for these axes.

Machine Modes - Modes are used to control how the machine behaves under certain conditions. The modes are as follows:

1. *Stopped* - The machine is on but the servo motor controllers are off. No machine movement can occur in this mode.
2. *Running* - The machine is operating normally and is quilting.
3. *Paused* - The machine is operating normally and is NOT quilting.
4. *Manual* - The user has accessed the Manual Operations Screen and can move the machine manually. NOTE: When leaving the Manual Operations Screen the machine will automatically Home-Out.
5. *Pendant* - This mode occurs when the user moves the selector switch on the pendant to any setting other than Auto or the Pendant button on the Main Run Screen is clicked.

Message Boxes -These boxes (shown below) are used any time the machine needs to convey information to the user.

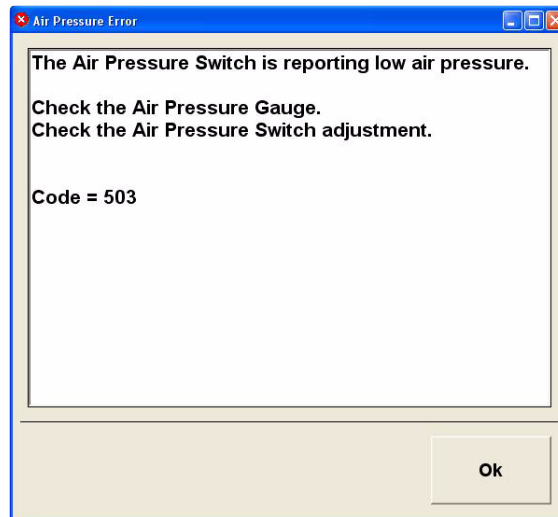

Power Off

The E-Z Quilter software accesses the hard drive of the PC during operation. It is highly recommended to close the software before turning the Main power off to the machine which also turns off the power to the PC. Do this by clicking the red "X" at the extreme top right of the E-Z Quilter software window.

For the purposes of this manual the terms *Click* and *Double-click* using a mouse also refers to "Pressing" a button using the touch screen.

Main Run Screen

The Main Run Screen is displayed the entire time the E-Z Quilter software is active. It is divided into 5 areas Machine Speed, Miscellaneous Information, Pattern Selection, Run History, and a row of Command Buttons.

E-Z Quilter - H:\EZQuilt\Patterns\AAC-II-001B.thb

Date: 03/19/07 **1392C GOLDEN EAGLE** Time: 08:13:57

Machine Speed

0 167 333 500 667 833 1000

Set RPM = 1000

Actual RPM = 1000

Adjustment Increment x 100

Miscellaneous Information

Yardage Counter **5.03** **Reset**

Yards per Run Minute 2.34

Current Mode **Normal** **Batch Information** Yards To Go **N/A**

Currently set for Normal Mode

Foot Height **Low** Current Status **Running**

Pattern - H:\EZQuilt\Patterns\AAC-II-001B.thb

Change Pattern

Needle Array
NA00002, 6 SPI

Size Adjustment

Pinch Roller

Run History Information

Machine Started	03/19/07 - 08:12
Machine Paused	03/19/07 - 08:11
Machine Started	03/19/07 - 08:11
Machine Paused	03/19/07 - 08:11
Machine Started	03/19/07 - 08:11
Batch Material Change	03/19/07 - 08:11
Machine Paused	03/19/07 - 08:10
Homing Machine	03/19/07 - 08:10
Servos have been turned on	03/19/07 - 08:10

Command Buttons: Turn Servos Off, Input/Output, Utilities, Pendant Manual, Finish Pattern, Help Language, **Pause**

Machine Speed

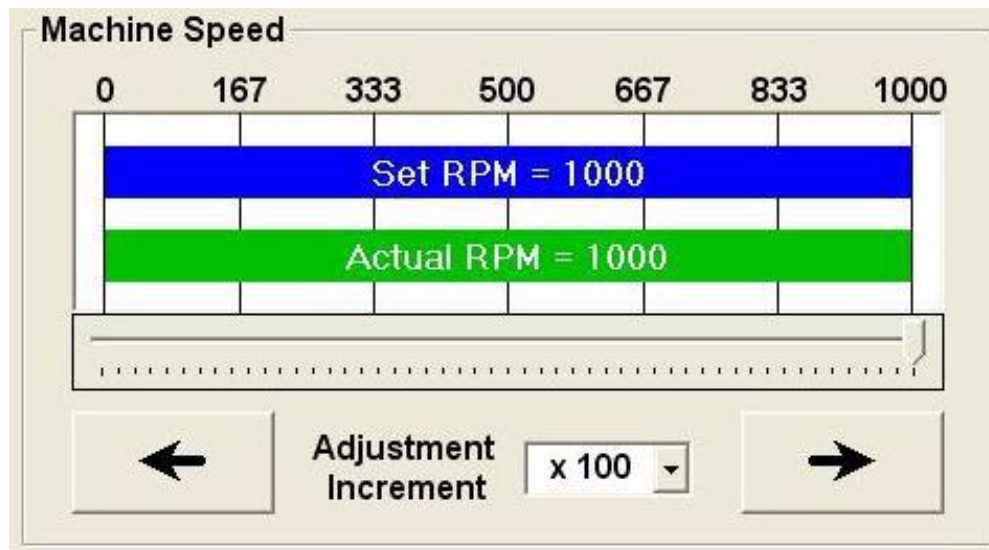

The Machine Speed display shows the Set RPM, Actual RPM, and various ways to adjust the Set RPM.

Set RPM is the RPM the machine will run once it accelerates to full speed.

Actual RPM is the RPM the machine is currently running.

The Set RPM can be adjusted two different ways:

1. There is a slider bar adjustment just below the Actual RPM display. Click and hold the horizontal bar then slide back and forth to make changes.
2. The two arrow buttons adjust the RPM up or down based on the increment shown in the box between the 2 buttons. The increment can be set to 1, 10, or 100 (default is 10).

The maximum RPM the machine can be set to is controlled by the Foot Height sensors.

Miscellaneous Information

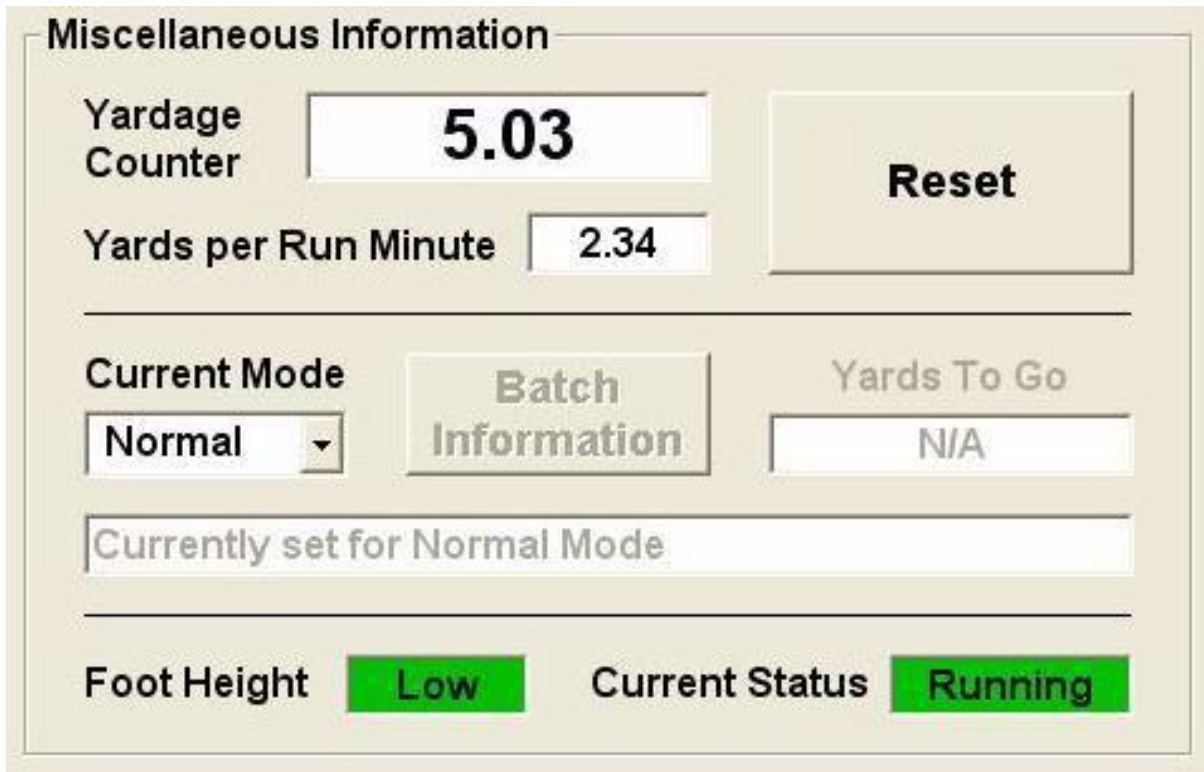

The screenshot shows a control panel titled "Miscellaneous Information". It contains several fields and buttons:

- Yardage Counter:** A digital display showing "5.03".
- Yards per Run Minute:** A digital display showing "2.34".
- Reset:** A large rectangular button.
- Current Mode:** A dropdown menu currently set to "Normal".
- Batch Information:** A button that is currently disabled (greyed out).
- Yards To Go:** A digital display showing "N/A".
- Foot Height:** A green button labeled "Low".
- Current Status:** A green button labeled "Running".

Below the "Current Mode" dropdown, there is a text field containing the text "Currently set for Normal Mode".

The Miscellaneous Information display shows current Yardage Information, Type of run mode, Foot Height, and Current Status.

1. **Yardage Information:** The Yardage Counter displays the current thru-put yards since the last time the Reset button was clicked. Yards per Run Minute displays current thru-put yards per minute. The machine needs to run for at least 1-2 minutes to get an accurate reading. When pausing the machine, changing patterns, and changing RPMs will temporarily affect this number.
2. **Current Mode and Batch Information:** For Future Use
3. **Foot Height:** Displays the current height of the foot.
4. **Current Status:** Refers to the mode the machine is currently operating in.

Here is a step by step on how to adjust the presser foot on your Quilter. You can adjust the presser foot height easily without disturbing any other timing adjustments.

Presser Foot adjustment procedure for 1392D

- Using the touch screen or pendant, place the quilter at 180 degrees.
 - Turn the presser foot adjustment wheel to lowest position.
 - Loosen the 8mm bolts on spring retaining cups at top of presser foot rods. Be cautious as these may be under a great deal of pressure. May require rod to be held by wrench.
 - Place 8 shims (typically half of desired material thickness) between throat plate and presser foot directly under presser foot rods. Shims should be same length as presser foot front to rear.
 - Loosen the 16 8mm bolts that hold the cam followers on the presser foot rods. Notice that the bearings on the cam followers will fall away from the cams.
 - Your presser foot is now sitting freely on the shims and that will become your lowest position upon completion.
 - From left to right begin re-tightening as follows.
 - With one hand pull the cam follower bearing up firmly against the cam and tighten the 8mm bolts so that the cam follower holds place on the presser foot rod. If done correctly you will not be able to spin the bearing with your fingers as they are snug against the lower surface of the cams. Do not apply excessive pressure or you will damage these bearings under a load. Repeat 8X
 - Again from left to right. Place the retaining cups on the springs and tighten 8mm bolt at top of presser foot rod. This may require you to hold the rod with a wrench as not to put lateral pressure on the cam followers. If you cannot collapse the spring enough by hand you can place the tip of a long screw driver on the head of the bolt directly behind the top of the rod and carefully pry down until the bolt is started.
 - Now you can turn the presser foot adjustment wheel to highest position. It should turn as easily as before, if not you have something in a bind., go back and double check that the spaces between the cam follower clamp and the bottom of the rod sleeve bearing (usually blue) are all identical. As well as vertical distance between the bottom of the needle bar and the top surface of the presser foot across the entire length of the presser foot. (This is a good reference point to assure you have properly aligned everything). If this varies just adjust as needed by loosening the 8mm bolt on the cam follower clamps.
 - Double check that the cam follower bearings are still all snug against the cams. And you are ready for operation again. I recommend starting the machine at a low rpm (200-300) and doing a final look over just to be certain everything is tight and adjusted properly as not to interrupt production once you start running material.

Foot Height

The image shows a control panel titled "Miscellaneous Information". It contains several fields and buttons:

- Yardage Counter:** A digital display showing "5.03".
- Yards per Run Minute:** A digital display showing "2.34".
- Reset:** A large button to the right of the yardage counter.
- Current Mode:** A dropdown menu currently set to "Normal".
- Batch Information:** A button located between the Current Mode dropdown and the Yards To Go field.
- Yards To Go:** A digital display showing "N/A".
- Foot Height:** A label with a green button set to "Low".
- Current Status:** A label with a green button set to "Running".
- Text Field:** A text area below the Current Mode dropdown containing the text "Currently set for Normal Mode".

Foot Height is defined as the distance between the bottom of the presser foot to the top of the needle plate. This distance is physically set on the machine with the use of a manual crank. Sensors mounted to the mechanism tell the controller the current height of the foot. Foot Height adjustment is necessary based on the thickness of the materials being quilted. Maximum RPM of the machine is related to the Foot Height.

The importance of the Foot Height is the closer the bottom of the foot is to the needle plate the higher the maximum RPM can be.

There are three heights associated with the foot.

1. Low - Maximum RPM at this height is 1275.
2. Medium - Maximum RPM at this height is 800.
3. High - Maximum RPM at this height is 500.

Pattern Selection

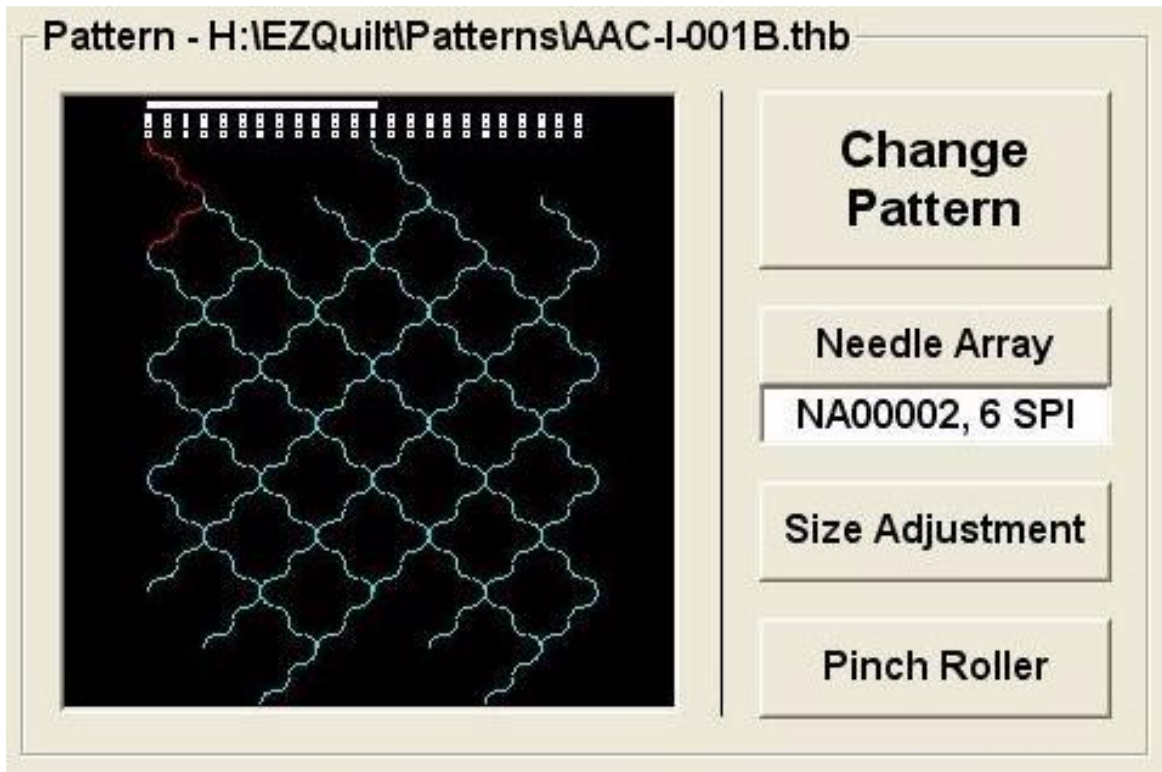

The Pattern Selection area displays the currently selected pattern, Needle Array Information, and Stitch Information.

The heading at the top of the frame displays the path and filename of the current pattern.

Clicking the Change Pattern button brings up the Pattern List screen to allow you to view and/or select a different pattern. The servos must be turned off before a pattern change is allowed.

The graphics area displays a visual representation of the current pattern. Double-clicking here will bring up the E-Z Pattern Design software with the current pattern loaded.

 **NOTE: If any changes are made, the pattern has to be re-loaded in the E-Z Quilter software.**

Clicking the Needle Array button displays the needle arrangement needed in the machine to achieve the displayed pattern. The Needle Array Code and Stitches per Inch are displayed in the box below the Needle Array button.

The Pinch Roller button opens and closes the Front Pinch Roller. When a Sew & Jump pattern is loaded, the Pinch Roller closes automatically. When a continuous pattern is loaded, the roller automatically opens. The Pinch Roller assists in feeding the foam and/or fill backwards. Anytime a pattern sews in the reverse direction, the roller should be closed.

Size Adjustments

When the Change Adjustment button on the Main Run Screen is clicked the Size adjustment screen is activated.

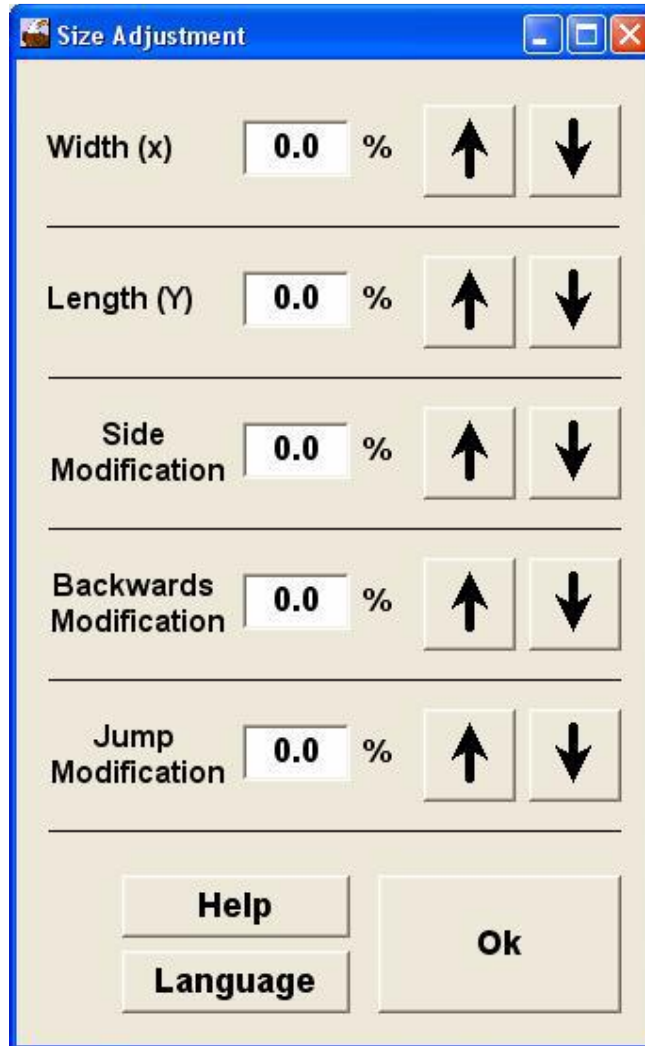

1. Width (X Axis) - Clicking the Arrow buttons increases or decreases the percentage in which the pattern will be stretched in that axis.
2. Length (Y Axis) - Clicking the Arrow buttons increases or decreases the percentage in which the pattern will be stretched in that axis.
3. Side Modification - Clicking the Arrow buttons increases or decreases the percentage in which the pattern is altered when the carriage (X Axis) moves toward Home. This is used to adjust the “roundness” of a circle.
4. Backwards Modification - Clicking the Arrow buttons increases or decreases the percentage in which the pattern is altered when the rollers (Y Axis) move in reverse. This is used to adjust the "roundness" of a circle.
5. Jump Modification - Clicking the Arrow buttons increases or decreases the percentage in which the Jump Move will be altered in the Y axis.

NOTE: Changes to these adjustments do not take effect while the machine is running. The machine must be reset and servos homed for the changes to take effect on the current pattern.

Pattern List

The Pattern List Screen displays all the patterns in a particular directory or folder. Patterns may be viewed but not loaded while the machine is running.

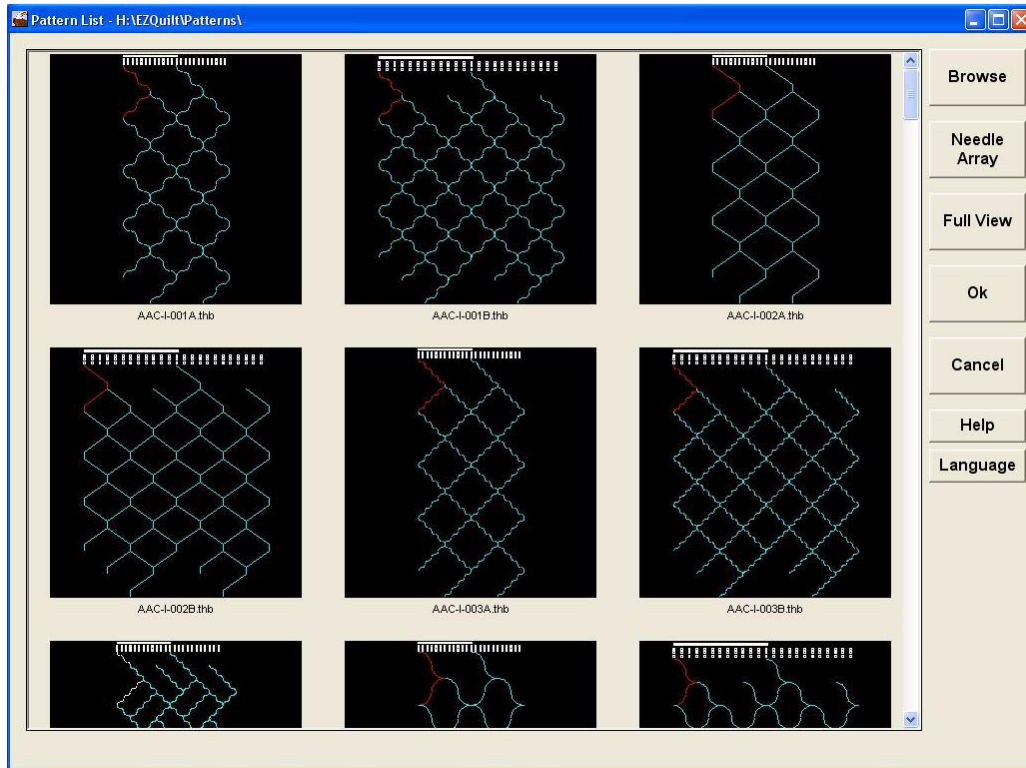

In order to see more patterns in the selected directory use the vertical slide bar to the right of the graphics display area.

Single-clicking a pattern selects or highlights the pattern.

Clicking the Needle Array button displays the needle arrangement needed in the machine to achieve the selected pattern. If no pattern is selected it displays the Needle Array for the first pattern in the list.

Clicking the Full View button will bring up the Pattern (Full View) screen displaying a larger view of the pattern.

Clicking the OK button loads the selected pattern into the machine. If no pattern is selected it loads the first pattern in the list. If the servos were not turned off prior to selecting the Change Pattern button, a message will appear to allow you to turn them off. Then the new pattern must be reselected prior to pressing the Ok button.

Clicking the Cancel button returns you to the Main Run Screen.

Clicking the Browse button allows you to navigate to a different directory containing patterns.

Pattern (Full View)

The Pattern (Full View) Screen displays a larger more detailed view of the selected pattern. Clicking anywhere on the screen will return you to the previous screen.

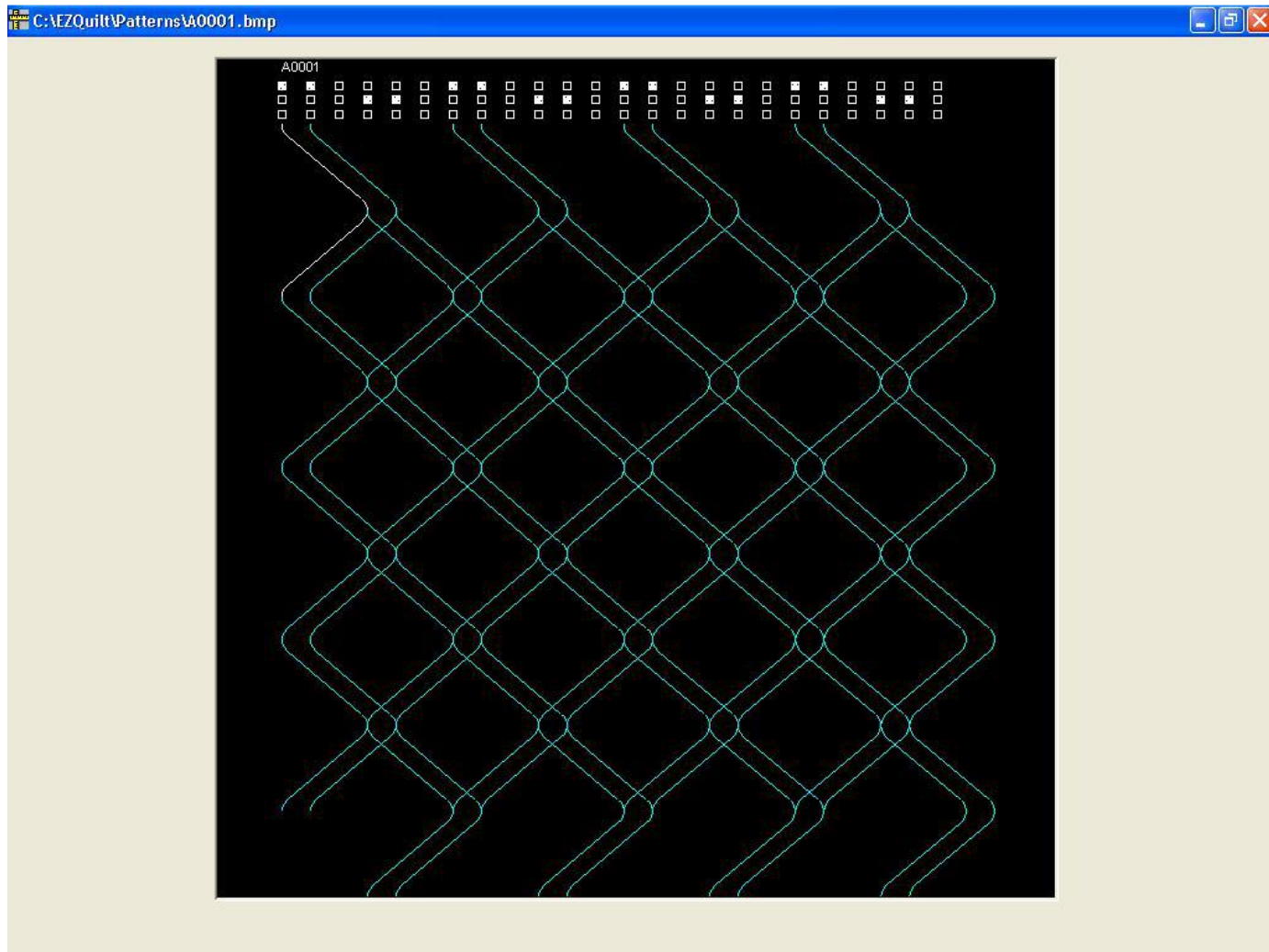

Needle Array

The Needle Array Screen displays the actual needle arrangement necessary to achieve the selected pattern. It only shows 24 Out of the 97 needles in each row which is enough to display a recurring pattern. If the pattern is a “Sew & Jump”, the Starting and Ending back tack is shown

Needle Array Codes are sequential numbers from NA00001 to NA99999. Each number represents a unique needle array. The needle array cannot be ascertained from the number only. Once a code is assigned that particular arrangement will always be associated with that code.

Stitches per Inch, Starting Back tack, and Ending Back tack values can be changed resulting in a permanent change to the pattern files and an automatic re-load of the pattern.

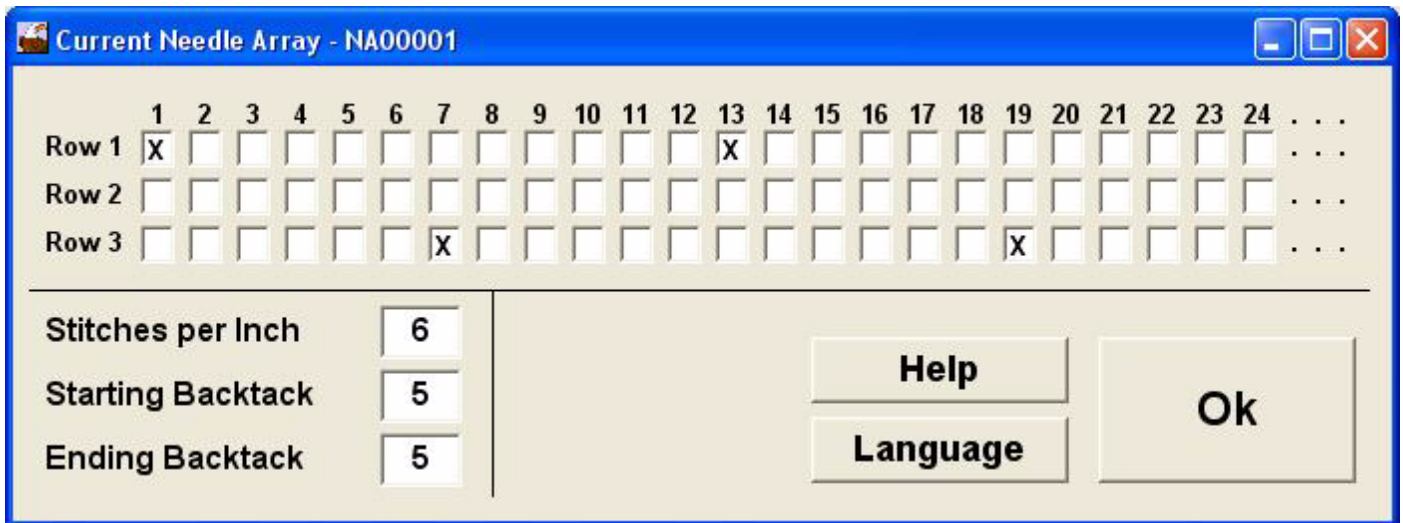

How-To Guide for Threading the 1392

From Thread Stand:

1. Take the thread behind the rod, through the eyelet, through the thread tensioner, through another eyelet, then inside the slotted thread break detector and pull down towards the needles.

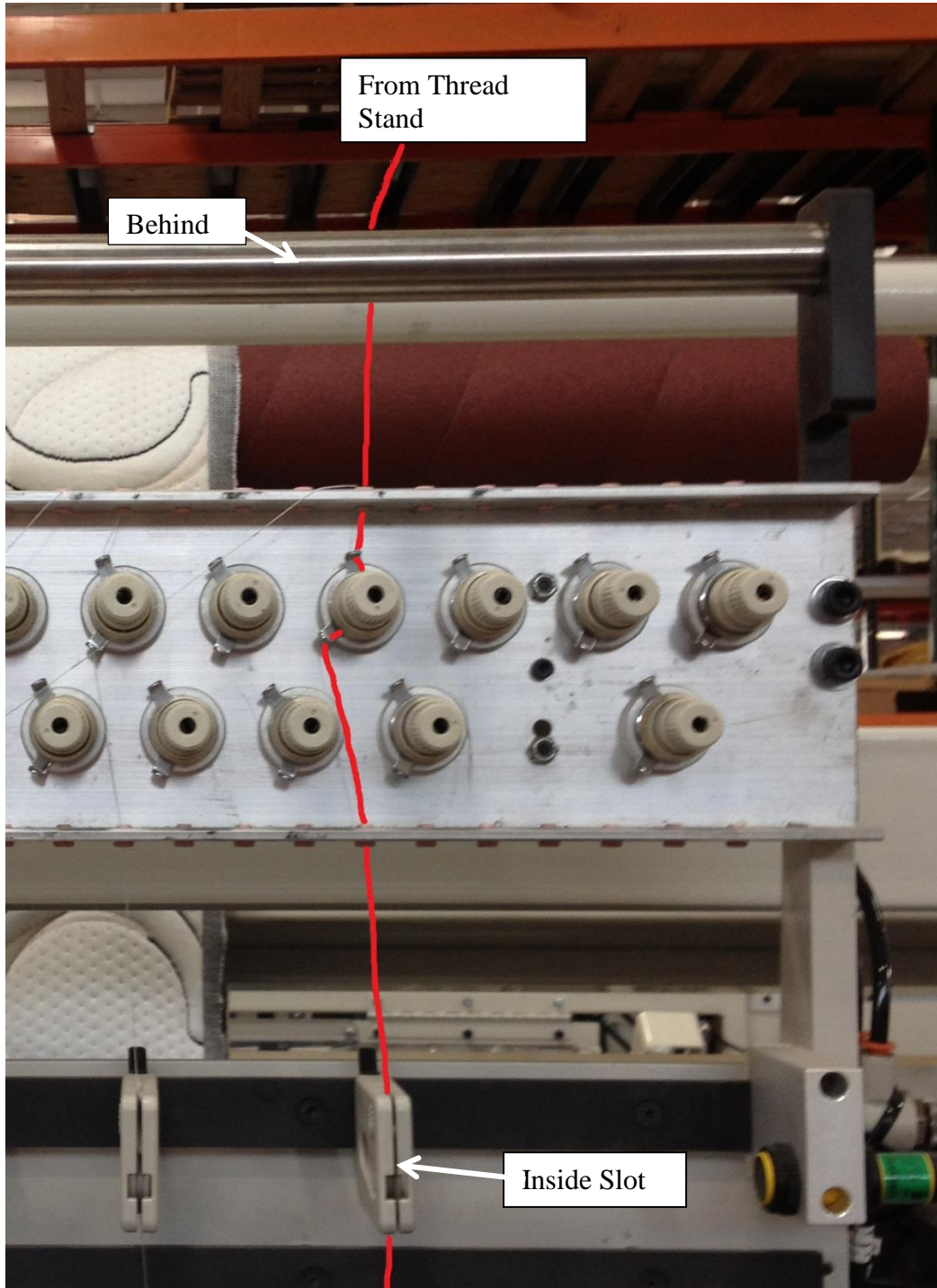

2. Route the thread under the farthest rod, under the second rod, under the butterfly tube, through the guides, then over another butterfly tube and then down through the guides and towards the needles.

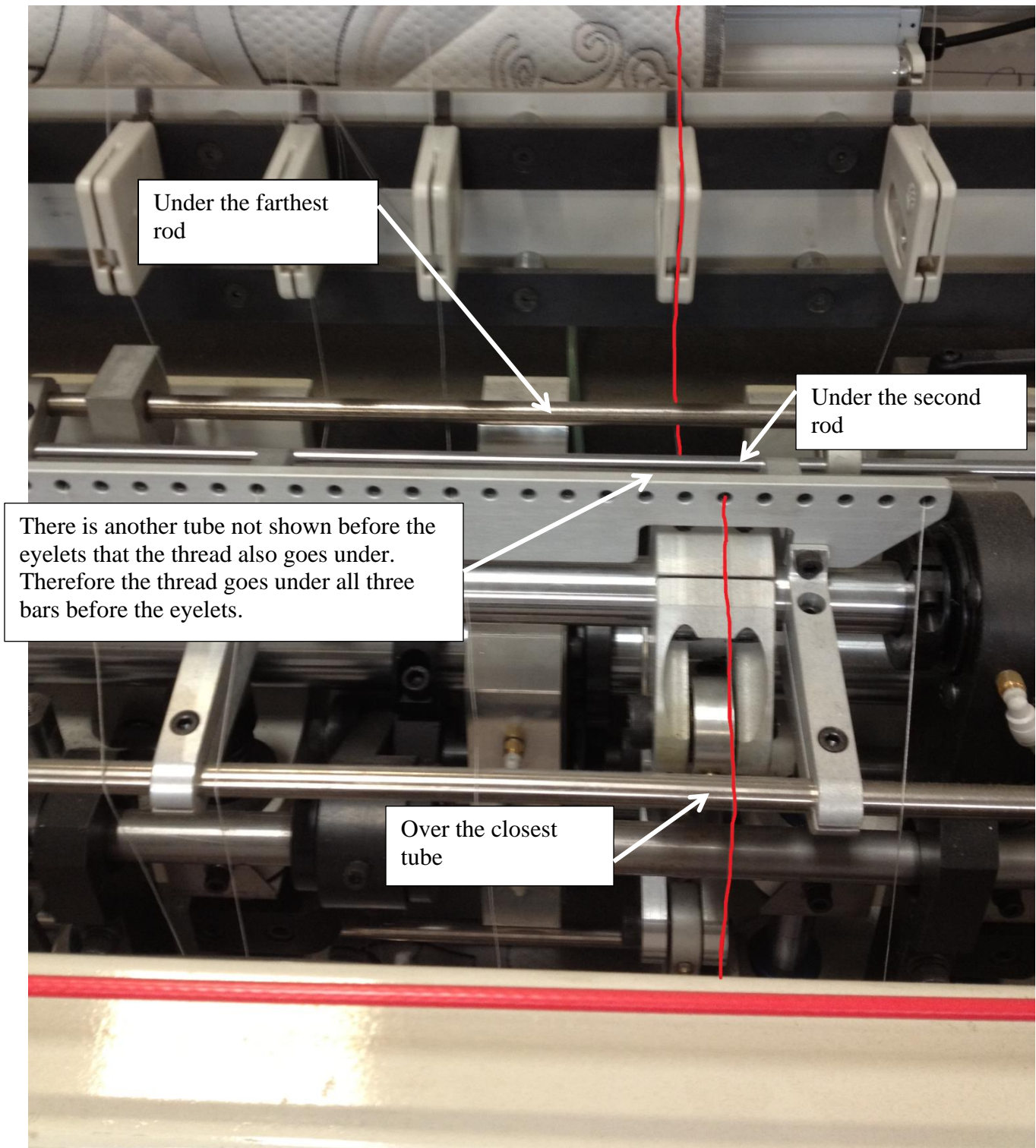

3. Route the thread from the rod down to the eyelets below.

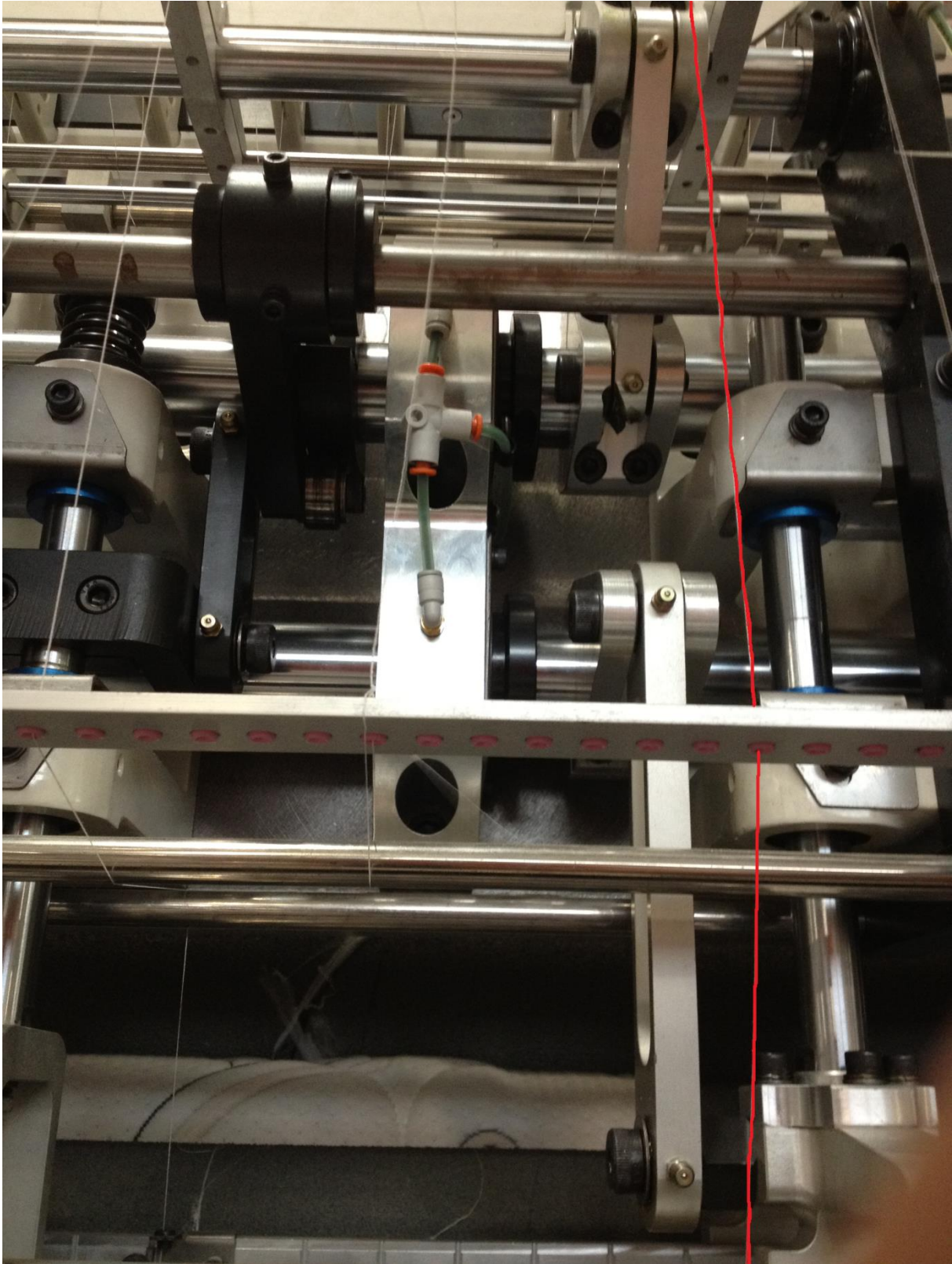

4. Thread the needles. The front needles are threaded straight down from the eyelets. The rear needles are threaded by routing the thread under the middle bar and over the rear bar and down to the needles. The middle needles are threaded similar to the rear needles but the thread only goes over the middle bar then down to the needles.

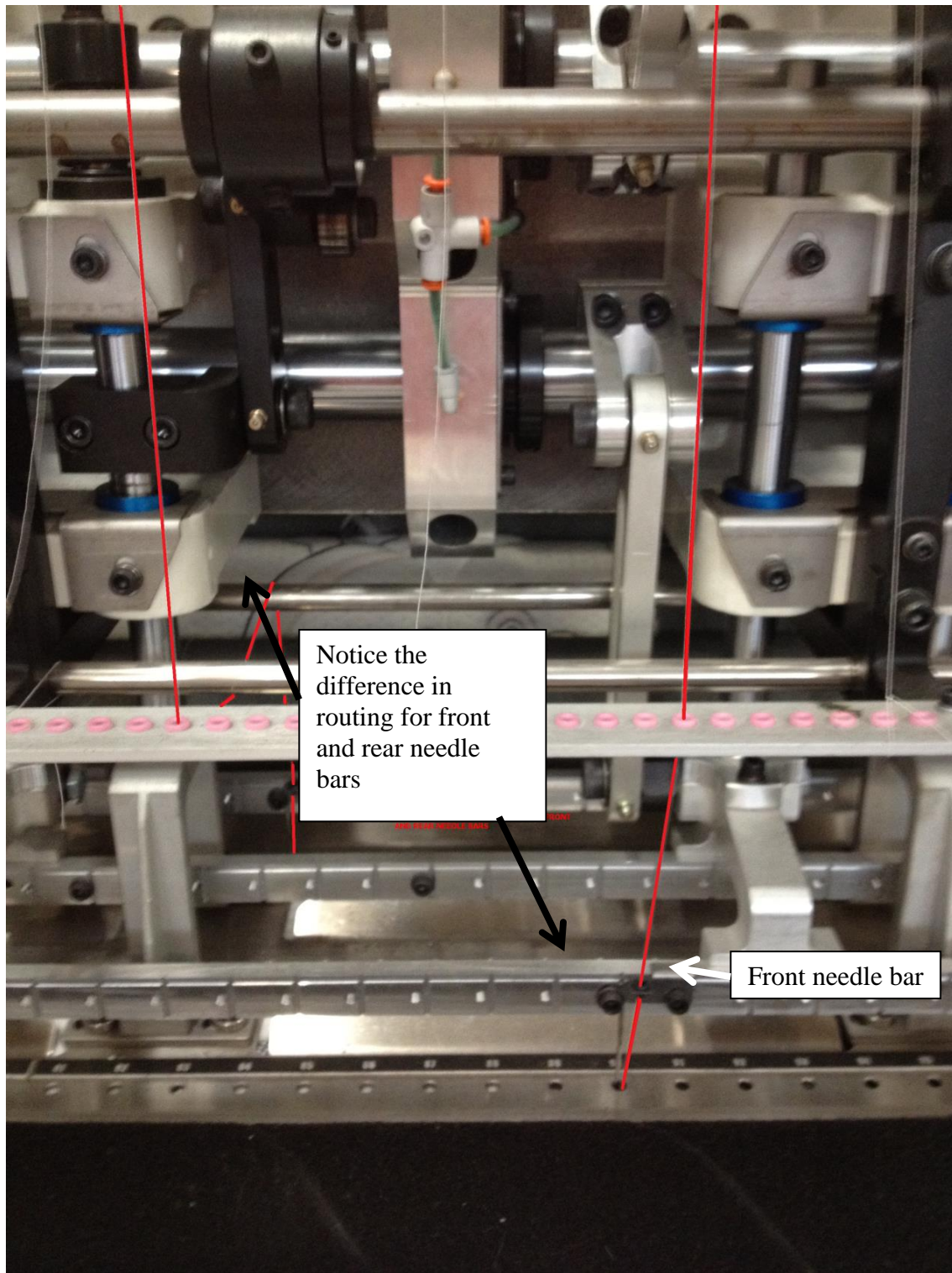

Looper Thread Routing:

1. Run the thread through the eyelet and thread tensioner. Then take the thread over the first bar.

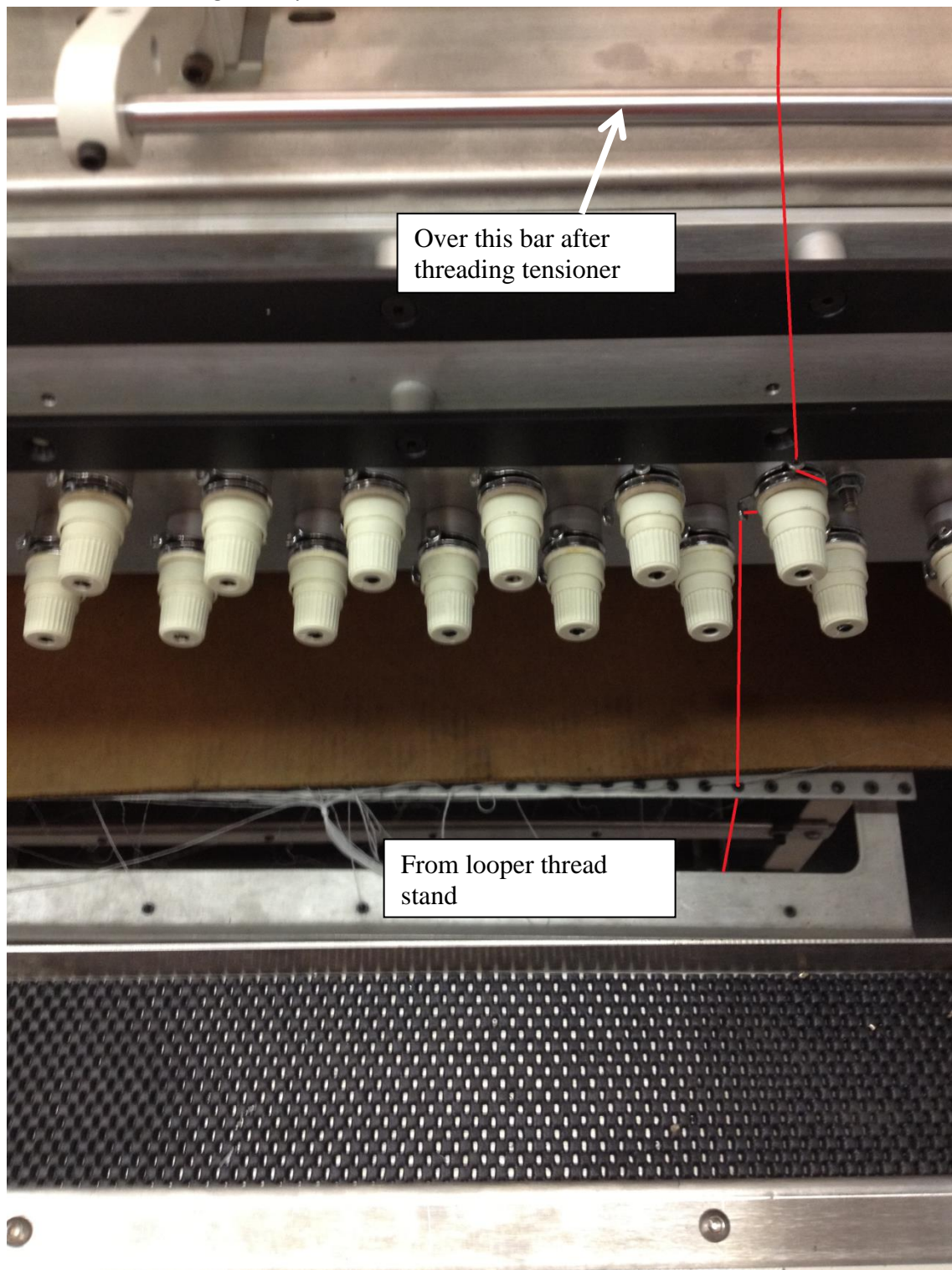

2. Route the thread over the first thread rod, under the second thread rod, then through the thread eyelets.

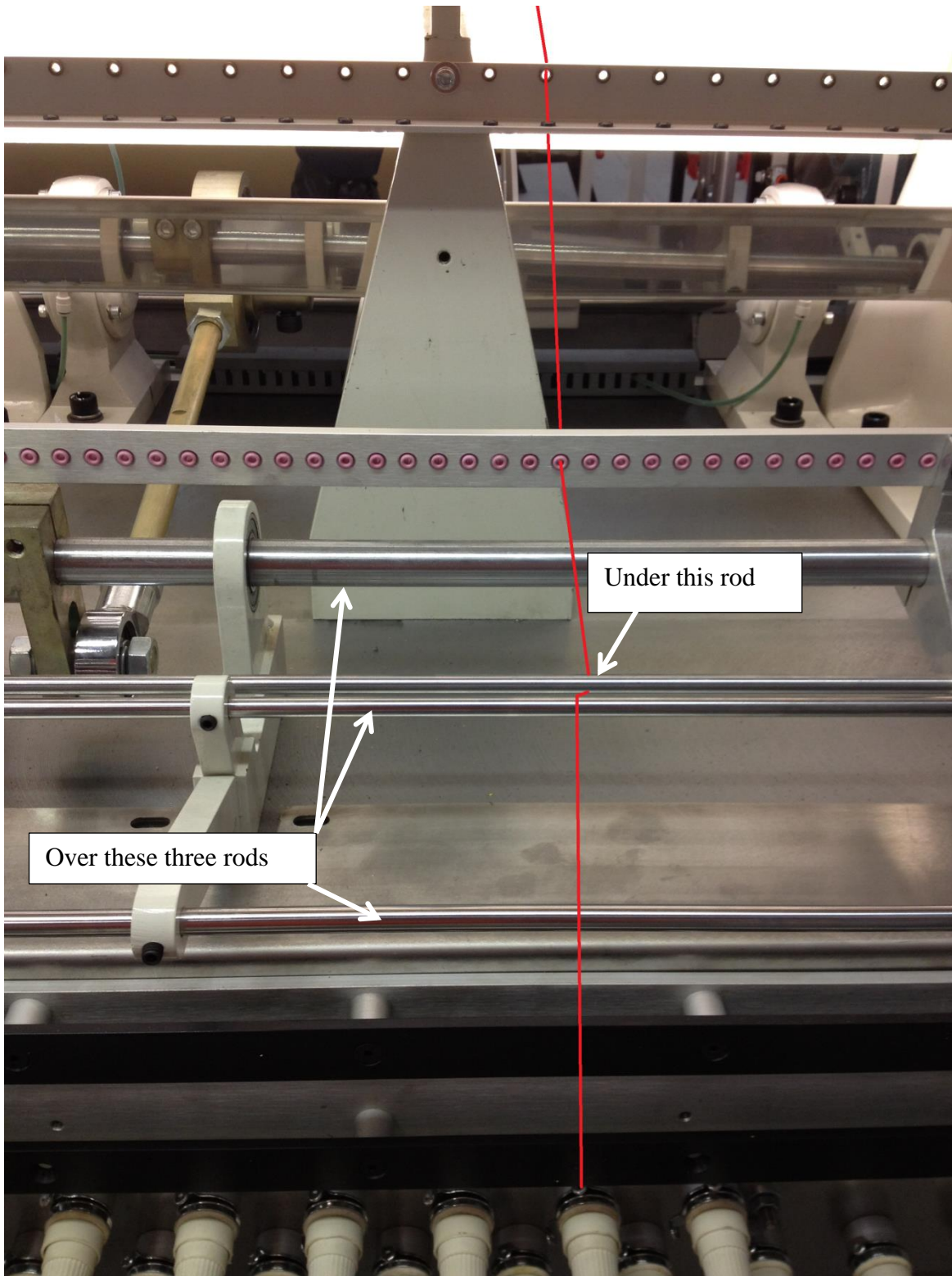

3. From the back looking at the loopers, route thread through the last set of eyelets and under the bar with the exception of the closest looper. Run thread straight from eyelet to looper.

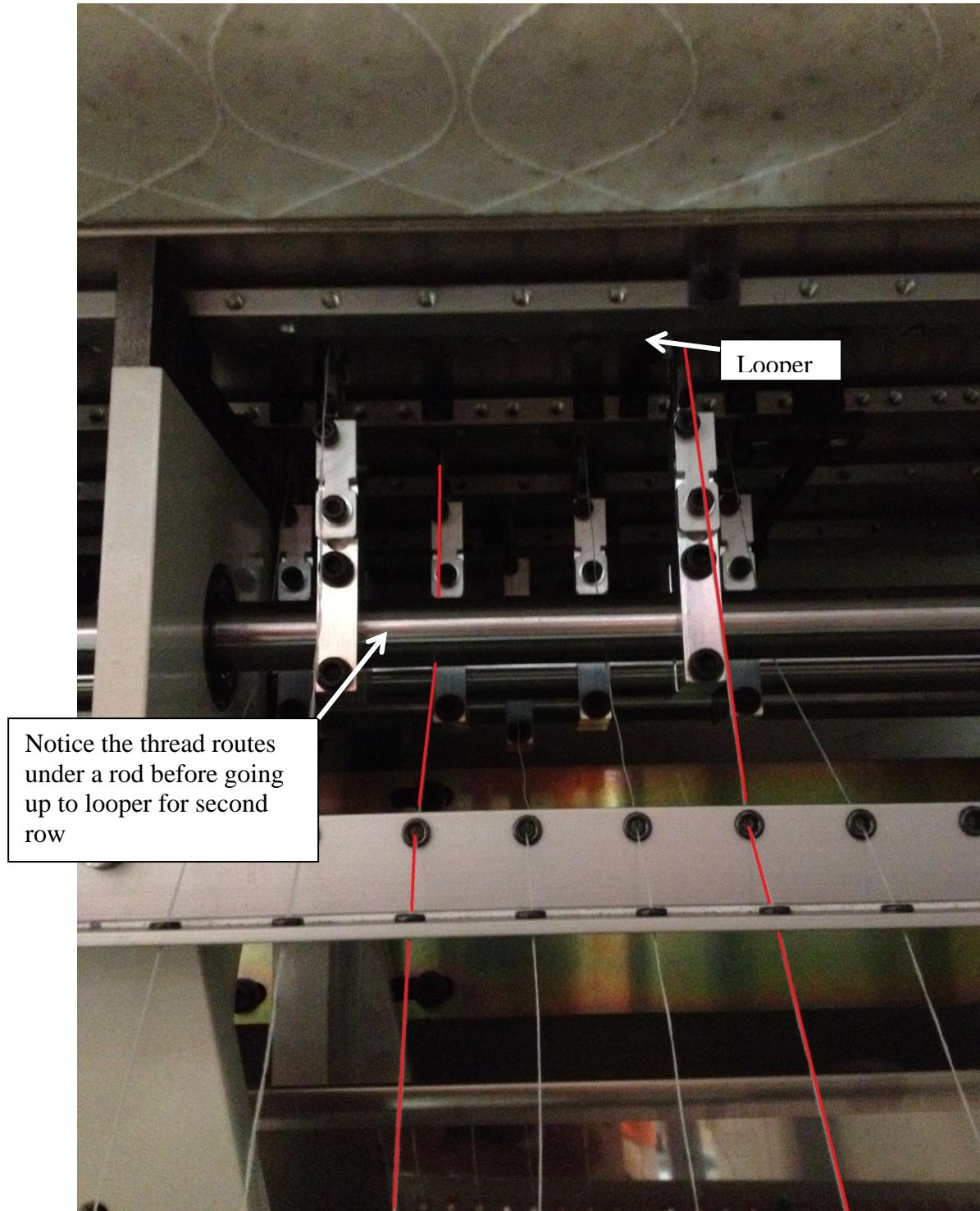

4. Once at the looper, guide the thread through the back of the looper and bring it around the side then through the front of the looper.

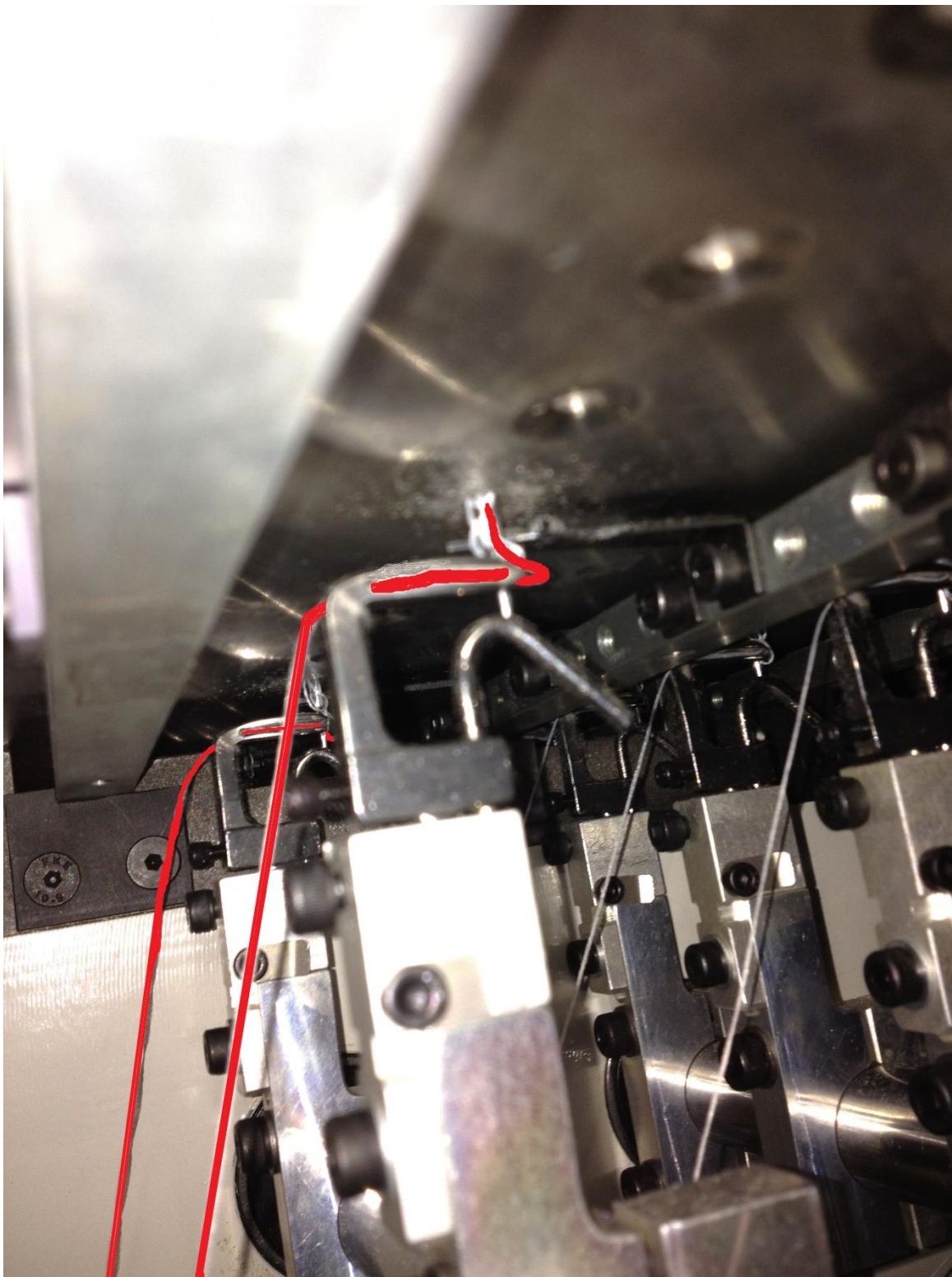

Command Buttons

The Command Buttons displayed along the bottom of the Main Run Screen provide user control of the machine and are as follows:

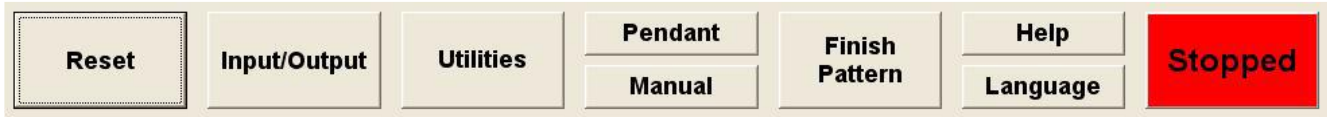

1. Reset / Servos On
2. Input / Output
3. Utilities
4. Pendant Mode
5. Manual
6. Finish Pattern - The Finish Pattern button pauses the machine at the end of a pattern.
For “Sew & Jump” patterns the machine pauses at the end of a jump.
7. Help - Displays this Help file
8. Language
9. Start / Status

The Reset/Servos On button is located at the lower Left corner of the Main Run Screen.

When the Servos are Off this button displays the caption *Reset*. When the Servos are On this button displays the caption *Servos On*.

When the button's caption displays *Reset* the servos are OFF and the machine is inoperable. Clicking the button turns on power to the Servos and homes-out the machine.



CAUTION: the machine will move during the homing function.

When the button's caption displays *Turn Servos Off* the servos are ON and the machine is ready to run.

Clicking the button turns off power to the Servos.



NOTE: When the Servos are off none of the Machine Axes will move.

The *Input/Output* Screen allows you to see the current state of the Inputs and Outputs. It also allows you to activate/deactivate the Outputs.



NOTE: This screen is primarily used to test the Inputs and Outputs. If you manually change the state of an Input it will not have an effect on the machine. However, if you click on one of the Output buttons it will reverse its state (if it is on it will turn off or if it is off it will turn on).

The screenshot shows a software window titled "Input/Output Devices" with a blue title bar and standard window controls. The main area is divided into three sections: "Input Status", "Output Status", and a "Note for INPUT devices only".

Input Status		Output Status	
Air Pressure Sensor	Ok	Servo Power	Off
Needle Up Sensor	On	Looper Thread Trim	Off
Needle Thread Sensor	On	Needle Tension Release	Off
Looper Thread Sensor	On	Looper Tension Release	Off
Pause Switch	Off	Bearing Lubrication	Off
Start Switch	Off	Spiral Motor	Off
Material Sensor	Ok	Front Pinch Roller	Off
Panel Cutter OK	Yes		
Handwheel Guard	Closed		
Fill / Backing Sensor	Ok		
Front Door 1	Closed		
Rear Door 1	Closed		
Rear Door 2	Closed		
Foot Height Range	Low		
Right Limit Switch (X)	Ok		
Left Limit Switch (X)	Ok		
Pendant Selection	Auto		
Pendant Buttons	Idle		

Note for INPUT devices only
While on this screen activating the listed INPUT devices will not affect the machine.

Buttons: Help, Language, Ok



The *Manual Operations* Screen allows you to move all three axes manually and independently.

NOTE: When moving the axes independently the synchronous relationship between them is lost. Therefore, when you exit this screen the machine will automatically Home-Out.

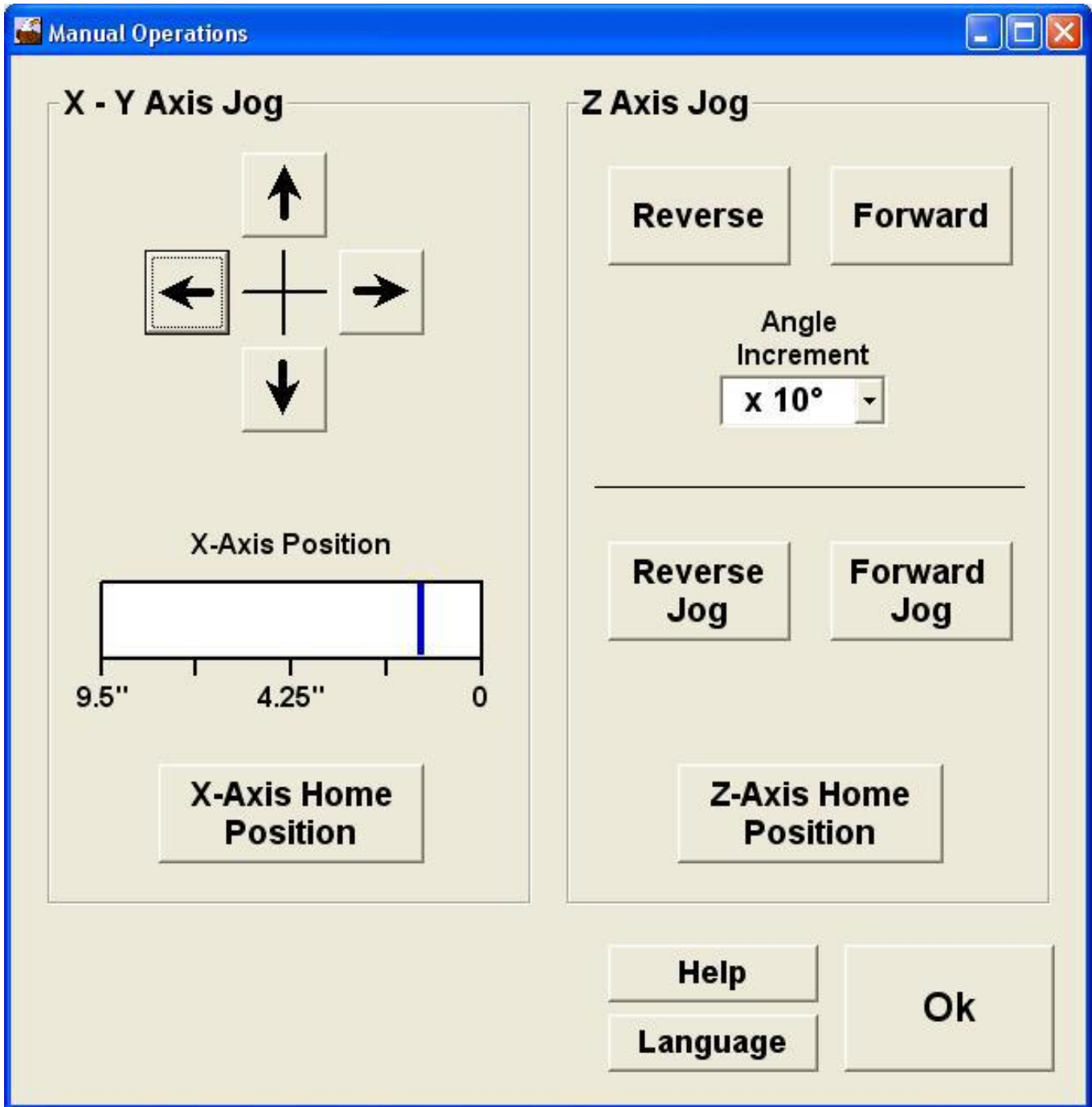

1. X -Y Axis Jog - See “ X-Y Axis Jog” on page 43
2. Z Axis Jog - See “on page 44

X-Y Axis Jog

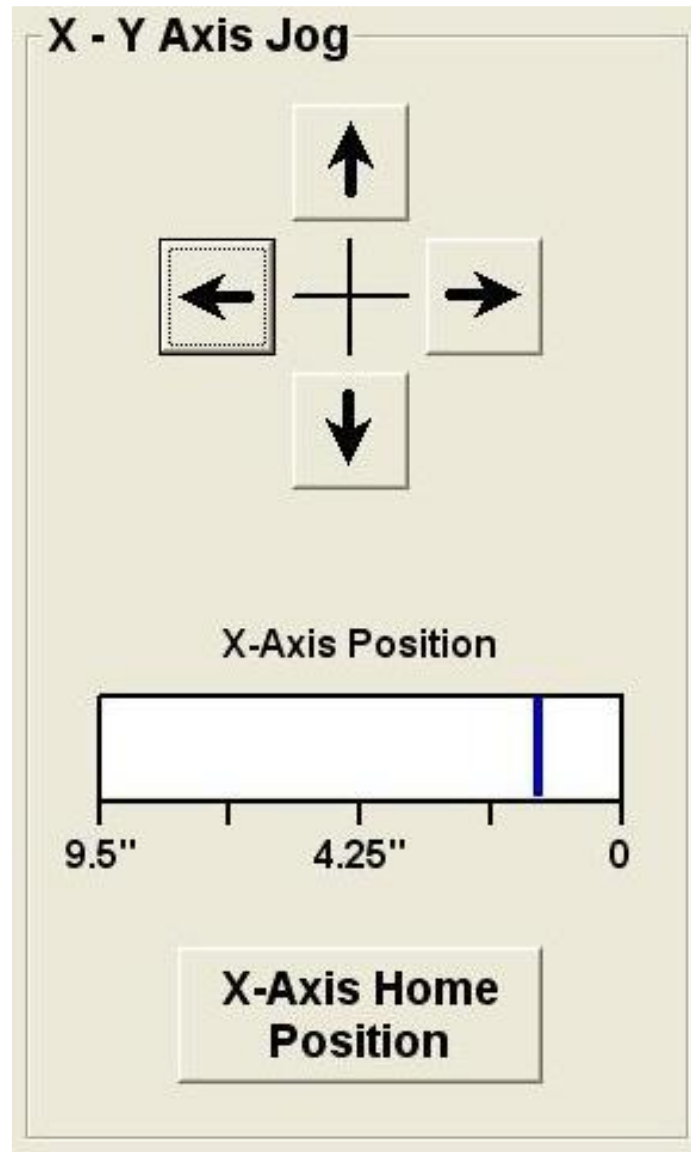

The Arrow buttons pointing left and right move the X-Axis (Carriage) in the Left and Right directions.

The Arrows buttons pointing up and down move the Y-Axis (Roller) in the Forward (Up) and Reverse (Down) directions.

The X-Axis Position is how far the Carriage is from Home position (in inches).

Clicking the X-Axis Home Position button moves the X-Axis (Carriage) to its Home position. Only the X-Axis will move.

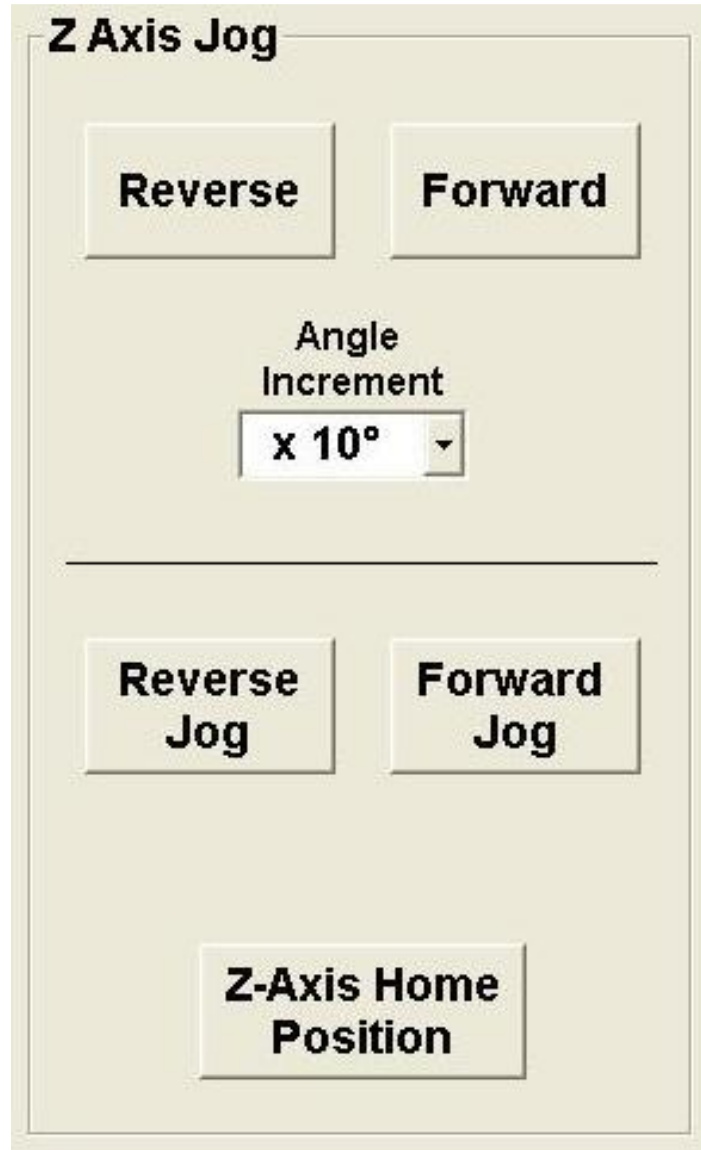
Z Axis Jog

The Reverse and Forward buttons move the Z-Axis (Needle) in the Reverse and Forward directions by the angular increment displayed above. Maximum reverse movement is 45 degrees.

The Reverse Jog and Forward Jog buttons move the Z-Axis (Needle) in the Forward and Reverse directions and will continue to move until the respective button is released.

Clicking the Z-Axis Home Position button move the Z-Axis (Needle) to its Home or needle-up position (zero degrees). Only the Z-Axis will move.

Pendant Operations

NOTE: For safety reasons, if the front door is open, the hand held pendant is disabled.

The Pendant Operations Screen duplicates the functionality of the physical Pendant attached to the machine. There are two ways to make this screen appear. One is to click the Command Button on the Main Run Screen. The second is to physically move the selector on the Pendant to any selection other than Auto.

NOTE: Regardless of what made this screen come up you have to click the Ok button to remove it (except in case of a Thread Break error).

Clicking the Disable Pendant button causes another button to appear labeled Index Pendant (see below). Clicking this button is the same as moving the selector on the physical Pendant. Clicking the red or green buttons above the Index Pendant button is the same as pressing buttons on the physical Pendant. Clicking the Pendant Disabled button re-enables the physical Pendant.

NOTE: If the Index Pendant button is visible, the physical Pendant is disabled.

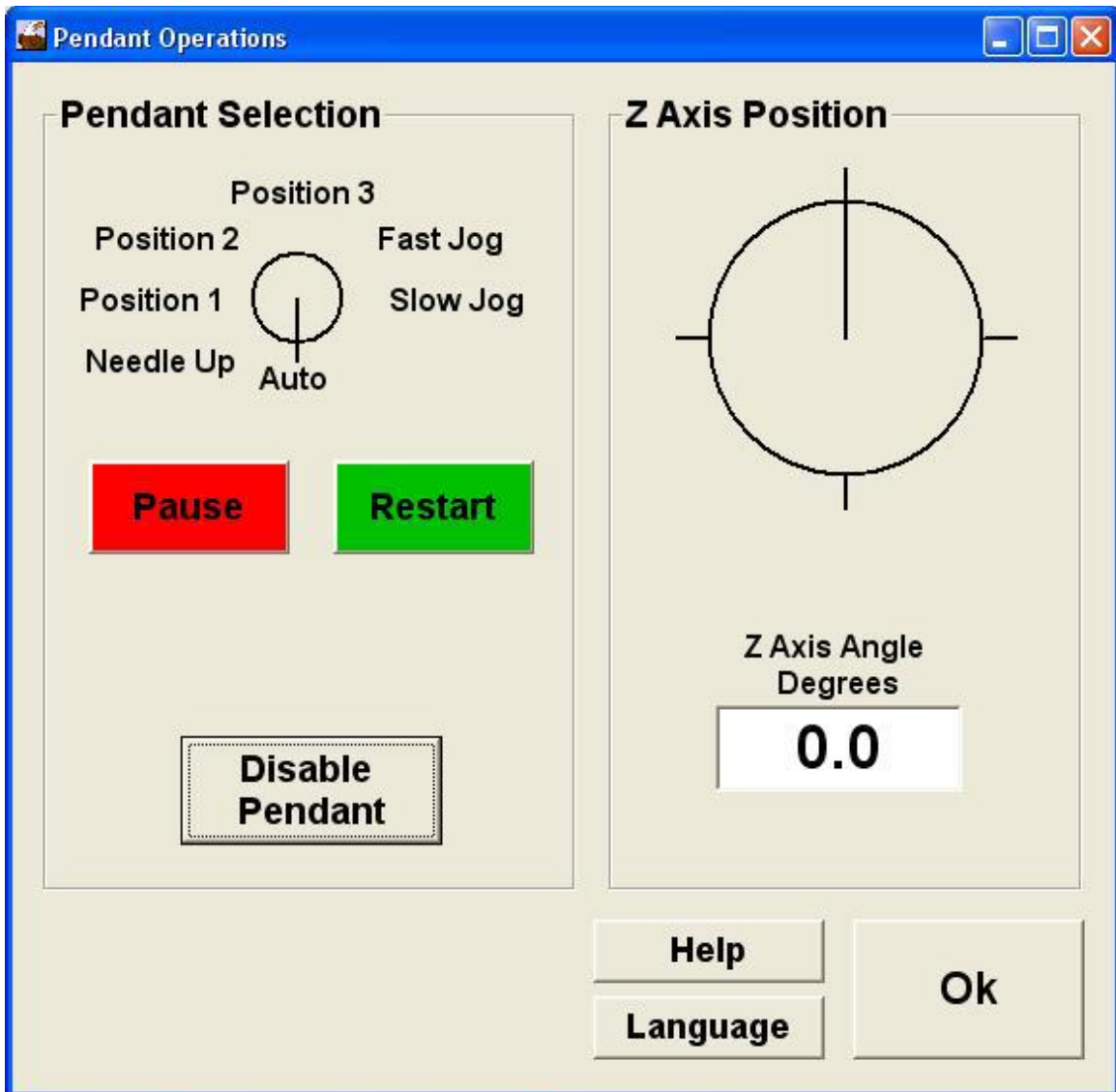

As you turn the selector the functions of the buttons change. See Table below

Selector	Red Button	Green Button	Function
Auto	Pause	Restart	Start/Pauses machine
Needle Up	Pause	Execute	Moves machine to the Needle Up position
Position 1	Pause	Execute	Moves Z-Axis to user-defined position
Position 2	Pause	Execute	Moves Z-Axis to user-defined position
Position 3	Pause	Execute	Moves Z-Axis to user-defined position
Fast Jog	Reverse	Forward	Moves Z-Axis fast till button release. Max. 45° in reverse
Slow Jog	Reverse	Forward	Moves Z-Axis slow till button release. Max. 45° in reverse

The Z-Axis position area graphically and numerically displays the angular position of the Z-Axis as it moves.

In case the Pendant becomes damaged or not functional for some reason this screen can perform the same functions as the physical Pendant.



Utilities

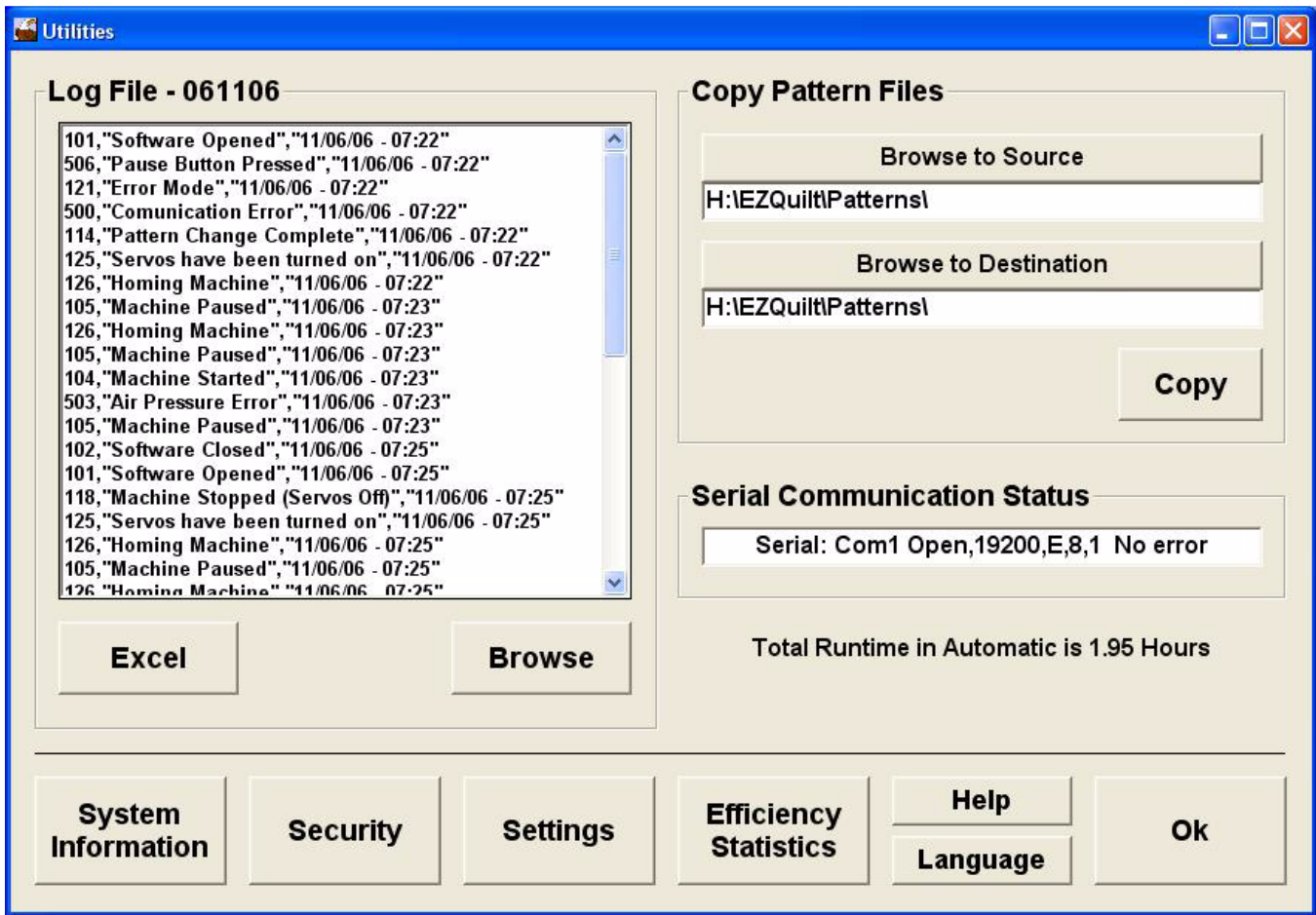

As its name implies the Utilities Screen have several functions.

1. Log Files (See “Log Files” on page 48.)
2. Copy Pattern Files (See “Copy Pattern Files” on page 49.)
3. Serial Communication Status - Monitors communication between the PC and the Servo Controller.
4. Total Runtime - Total Runtime is only accumulated when the machine is actually running in Automatic mode.
5. System Information (See “System Information” on page 50.)
6. Security (See “Security” on page 51.)
7. Settings (See “Settings” on page 52.)
8. Efficiency Statistics (See “Efficiency Statistics” on page 57.)

The next few pages will provide more detail into each function.

Log Files



By default the Log File displayed is the file for the current day. Note the filename of the Log File is 060218.txt, this represents 02/18/06 or February 18th, 2006. 06 is the year, 02 is the month, and 18 is the day.

There is also an Error Log File which has the same filename except it is preceded with an E. Using the same example as above the Error Log filename would be E060218.txt. This file is mainly used for troubleshooting.

All Log Files are stored in a directory called C:\EZQuilt\Logs\.

 **NOTE: Log Files are automatically deleted after a number of days defined by the "Keep Log Files for" Setting.**

Clicking the Browse button allows you to navigate to a different Log file.

 **NOTE: For the Excel function to work Microsoft Excel has to be installed on this computer.**

Copy Pattern Files

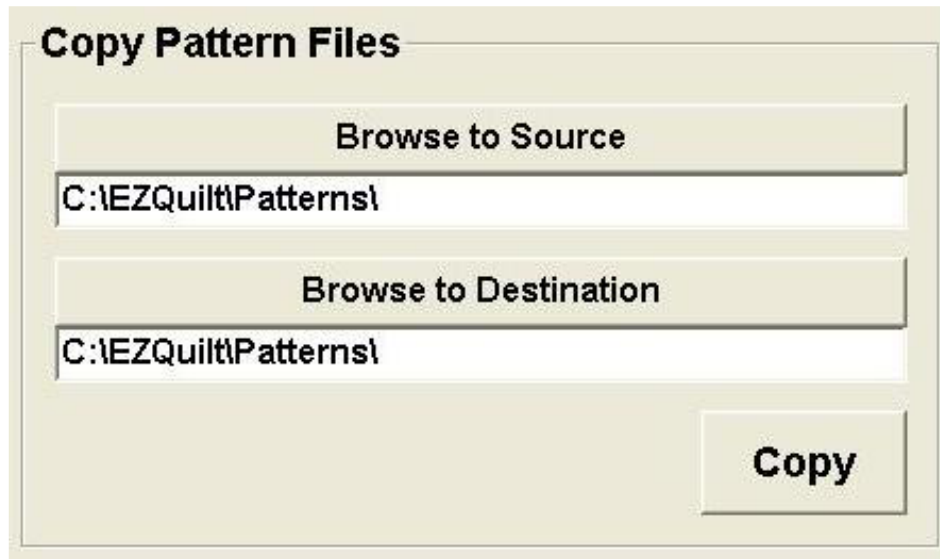

If new patterns are created on a different computer they have to be copied to the PC running the quilter. Since there are six separate files associated with each pattern this Copy function was developed to facilitate the process.

Browse to Source and Browse to Destination - Clicking either of these buttons will bring up the Browse screen which allows you to navigate to and select the appropriate directory.

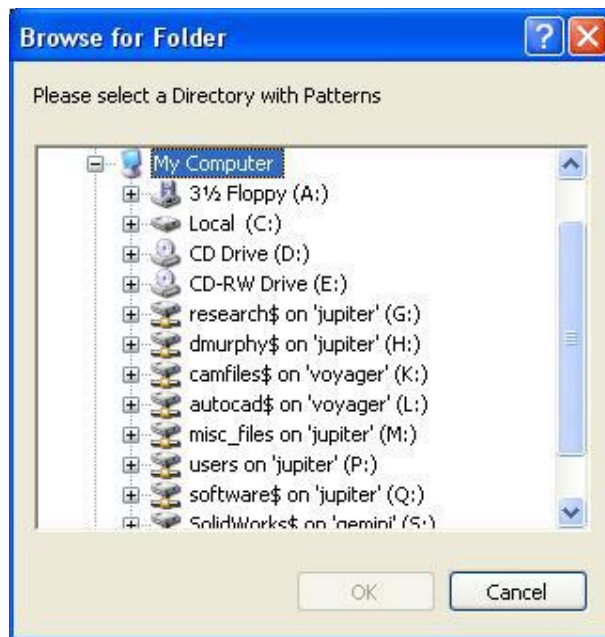

Source - The Source directory is the location where the files to be copied reside. Examples would be a memory stick, a floppy disk or a network drive.

Destination - The Destination directory is the location where the selected files will be copied to. Unless changed by the user this location should always be C:\EZQuilt\Patterns\

System Information

System Information shows Company Information and Revision History.

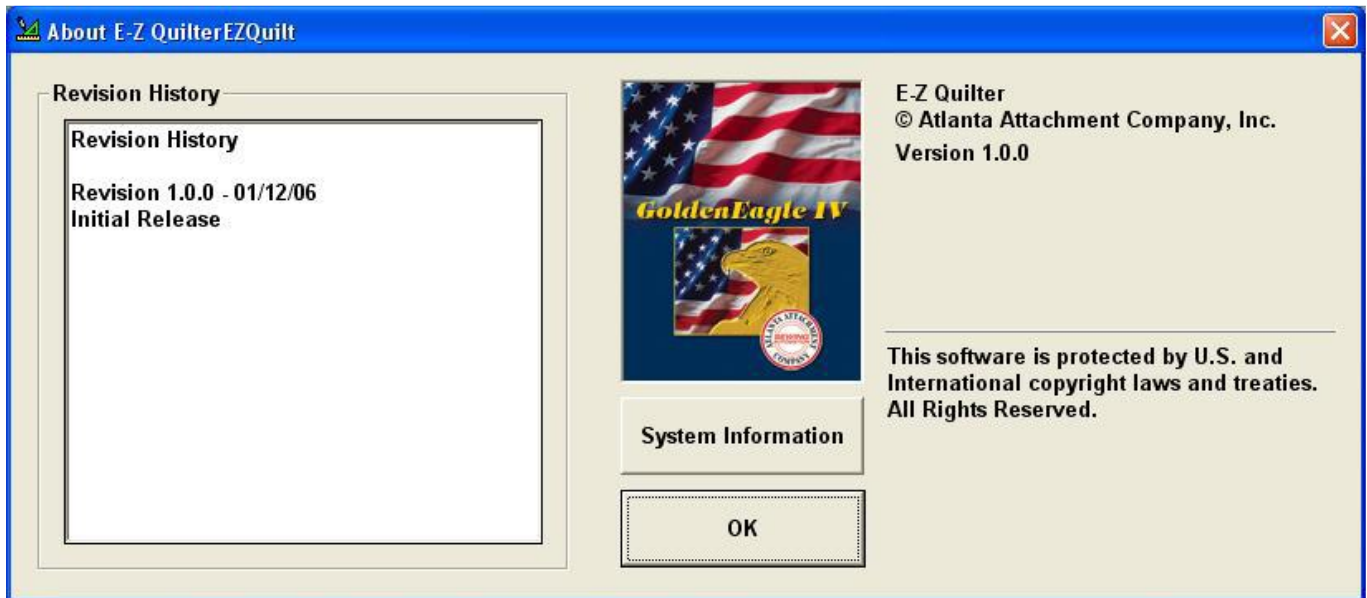

Clicking the System Information button displays configuration and hardware settings for the PC.

Note: In order to get to the Settings screen and various other functions an increased security level is required.

Security

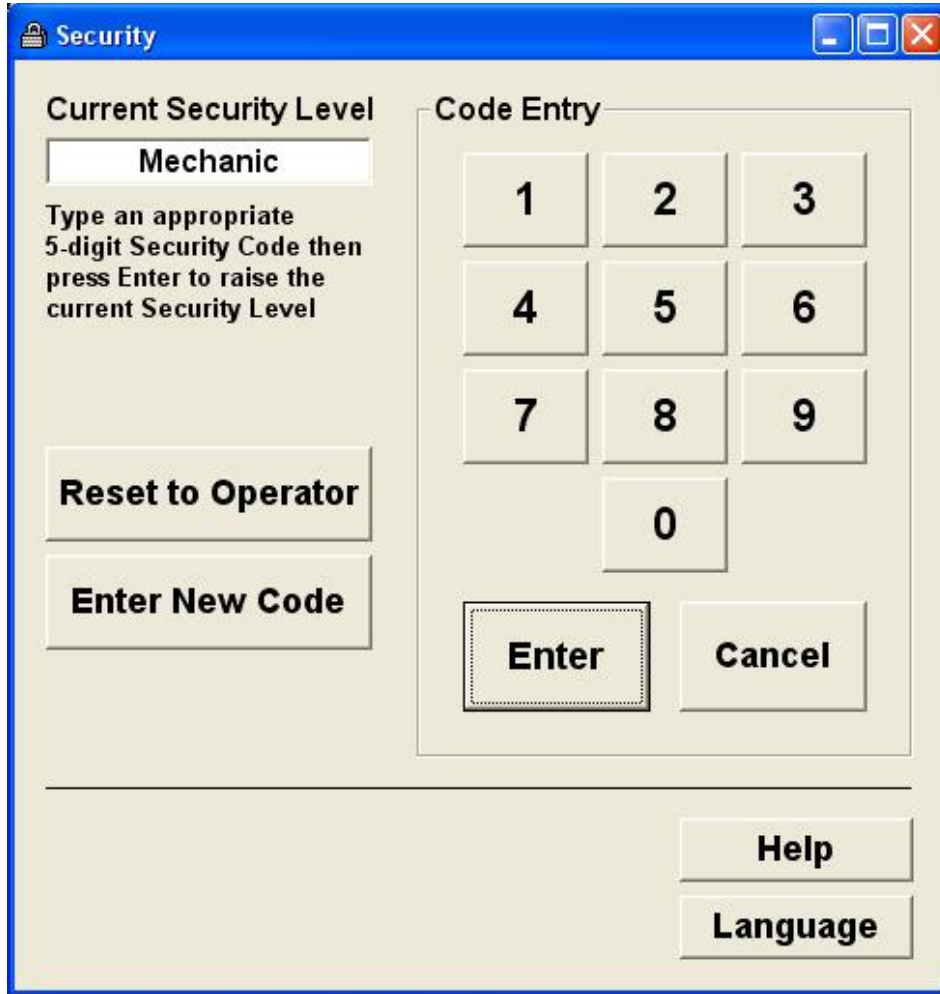

Security levels from lowest to highest are as follows:

1. Operator
2. Supervisor
3. Mechanic
4. Head Mechanic

Operator is the default level. There is no code for this level. When the machine is turned on it is always at this level.

The codes can be changed for each level by following the instructions on the screen (see above).



NOTE: Once someone has raised the current security level to something other than Operator (for example to Mechanic) the machine will stay at this level until the machine is turned off or the **Reset to Operator** button is clicked.

Settings

 The Settings screen allows you to make adjustments to various aspects of how the machine functions. **NOTE: A security level of Mechanic or higher is necessary to access this screen.**

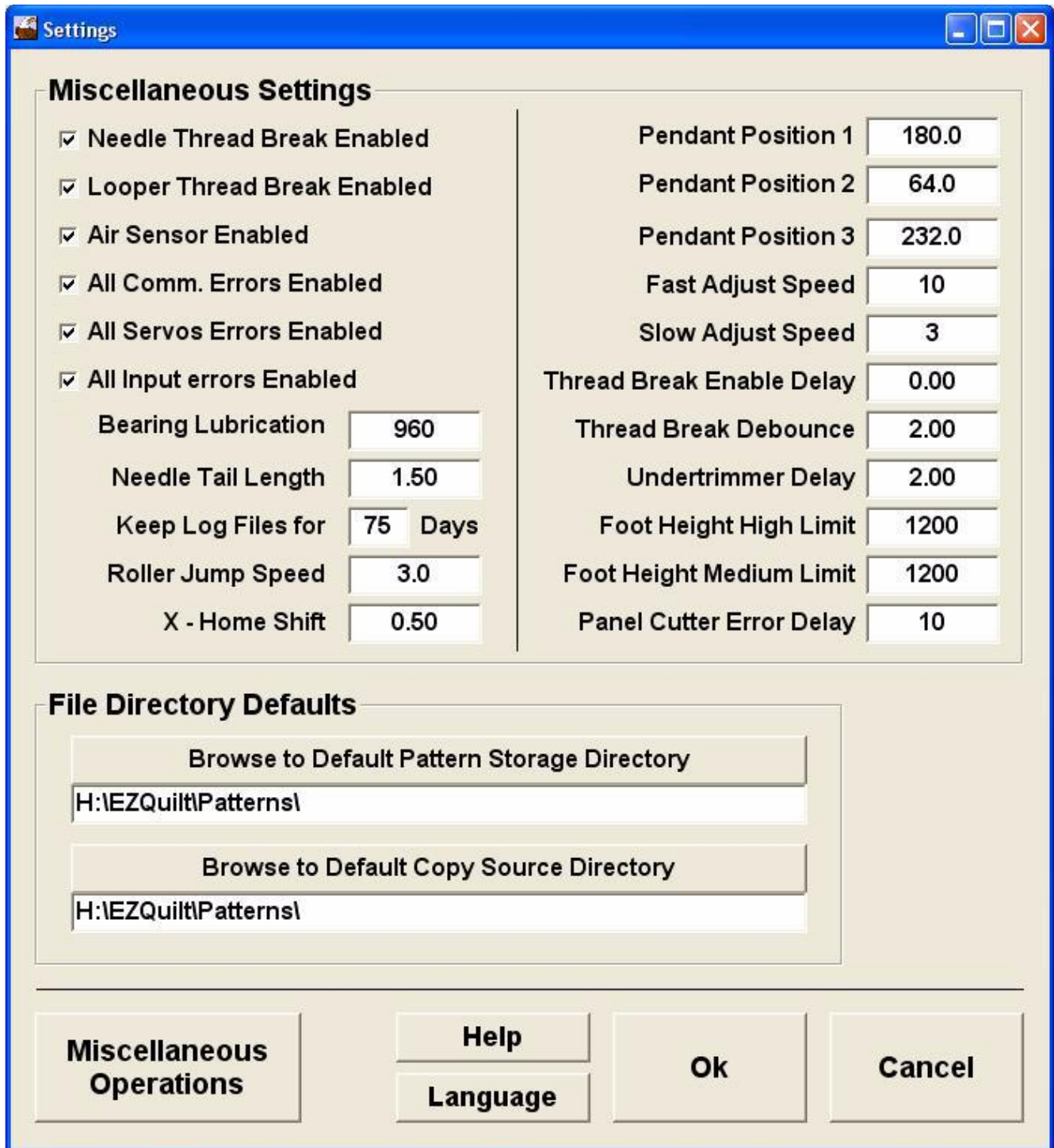

The screenshot shows a 'Settings' window with two main sections: 'Miscellaneous Settings' and 'File Directory Defaults'. The 'Miscellaneous Settings' section contains a list of checkboxes for enabling various error messages and several numeric input fields for adjusting machine parameters. The 'File Directory Defaults' section contains two buttons for browsing to default directories, both of which are currently set to 'H:\EZQuilt\Patterns\'. At the bottom of the window are buttons for 'Miscellaneous Operations', 'Help', 'Language', 'OK', and 'Cancel'.

Miscellaneous Settings	
<input checked="" type="checkbox"/> Needle Thread Break Enabled	
<input checked="" type="checkbox"/> Looper Thread Break Enabled	
<input checked="" type="checkbox"/> Air Sensor Enabled	
<input checked="" type="checkbox"/> All Comm. Errors Enabled	
<input checked="" type="checkbox"/> All Servos Errors Enabled	
<input checked="" type="checkbox"/> All Input errors Enabled	
Bearing Lubrication	960
Needle Tail Length	1.50
Keep Log Files for	75 Days
Roller Jump Speed	3.0
X - Home Shift	0.50
Pendant Position 1	180.0
Pendant Position 2	64.0
Pendant Position 3	232.0
Fast Adjust Speed	10
Slow Adjust Speed	3
Thread Break Enable Delay	0.00
Thread Break Debounce	2.00
Undertrimmer Delay	2.00
Foot Height High Limit	1200
Foot Height Medium Limit	1200
Panel Cutter Error Delay	10

File Directory Defaults	
Browse to Default Pattern Storage Directory	H:\EZQuilt\Patterns\
Browse to Default Copy Source Directory	H:\EZQuilt\Patterns\

Buttons: Miscellaneous Operations, Help, Language, OK, Cancel

The following pages provide more detailed information for each setting.

For the settings that have a check box a check in the box means the statement is true. For example, a check next to Air Sensor Enabled means that it is enabled and if air pressure drops below a certain point while the machine is running an error message box will be displayed.

The numeric settings have upper and lower limits. If you type in a number higher than the limit the entry will automatically change to the upper limit. The same happens with the lower limit, it will automatically change to the lower limit.

For the numeric settings clicking on the name of the setting displays a message box containing an explanation of that particular setting.

Needle Thread Break Enable

The machine is equipped with Needle Thread Break Detectors. Sometimes during setup or for troubleshooting it is convenient for the machine not to stop if a thread break occurs. Removing the check mark disables the Needle Thread Breaks.

Looper Thread Break Enable

The machine is equipped with Looper Thread Break Detectors. Sometimes during setup or for troubleshooting it is convenient for the machine not to stop if a thread break occurs. Removing the check mark disables the Looper Thread Breaks.

Air Sensor Enable

The machine is equipped with an Air Pressure Sensor. Sometimes during setup or for troubleshooting it is convenient for the machine not to stop if the air pressure is low or off. Removing the check mark disables the Air Sensor.



NOTE: All air activated devices such as the undertrimmer will not function correctly without proper air pressure.

All Communication Errors Enable

There are two channels of communication in the machine. The PC communicates with the Servo Controller and the Servo Controller communicates with the Servo Motors. Removing the check mark disables all the communication errors. This is only used in initial setup or troubleshooting of the machine.

All Servo Errors Enable

There are three Servo Motors on the machine the X, Y and Z axis. If an error occurs at the motor level it can be ignored by removing the check mark thus disabling all servo errors. This is only used in initial setup or troubleshooting of the machine.

All Input Errors Enabled

Most error conditions need only be active while the machine is running. For example if the machine is currently paused you would not want an error message if a door were opened. Removing this check mark disables all errors pertaining to input devices that do not have an individual setting such as thread breaks. An example would be opening a door.

Bearing Lubrication Interval

The machine is equipped with an automatic lubrication device. This device sends lubricant to various points on the machine. This setting controls how often the device sends lubricant and is based on actual machine runtime.

Runtime is only accumulated when the machine is actually running in Automatic mode.

Needle Tail Length

When running a Sew & Jump pattern and the first repeat is finished the machine must move to the next pattern repeat. During this move a Needle Tail must be created in order to start sewing the next repeat properly. This is accomplished by moving this setting's distance, pausing the move just long enough for the undertrimmer to activate, then continuing the move.

Limits: Minimum - 0.75 Maximum - 2.00 Default - 1.50

Unit of Measure - Inches

Log Files are automatically deleted after the number of days defined by this setting.

Roller Jump Speed

Roller Jump Speed is the feed rate that the Y-Axis (Roller) moves the material between pattern repeats when running a Sew and Jump pattern.

Limits: Minimum - 50 Maximum - 250 Default - 200

Unit of Measure - RPM

X - Home Shift

When using Size Adjustments to stretch a pattern sometimes the changes cause the machine to move to farther to the right possibly causing a Right Limit Switch error. When this amount of adjustment is necessary the X - Home Shift setting needs to be increased. A machine reset is required if the setting is changed.

Limits:

Minimum - 0

Maximum - 2.00

Default - .50

Unit of Measure - Inches

Pendant Positions 1, 2, and 3

Pendant Positions 1, 2, and 3 are user settable needle timing positions. These positions can be set to whatever angle you find convenient. These settings are used only in conjunction with Pendant Mode.

Limits: Minimum - 0 Maximum - 359 Default - Various

Unit of Measure - Angular Degrees

Fast Speed Adjust (Jog)

Fast Speed Adjust (Jog) is only used in Pendant and Manual Mode and is the faster of the two speeds the Z-Axis (Needle) moves when activated in either of these modes.

Limits: Minimum - 0 Maximum - 20 Default - 10

Unit of Measure - RPM

Slow Speed Adjust (Jog)

Slow Speed Adjust (Jog) is only used in Pendant and Manual Mode and is the slower of the two speeds the Z-Axis (Needle) moves when activated in either of these modes.



NOTE: If Slow Speed is set to a value higher than Fast Speed then Slow Speed is automatically changed to equal the Fast Speed. Therefore, Slow Speed can never exceed Fast Speed.

Limits: Minimum - 0 Maximum - 10 Default - 5
Unit of Measure - RPM

Thread Break Enable Delay

When the machine is not running the Thread Break eyes are dark as in an actual Thread Break condition. When the machine starts running, it takes a few seconds for the thread detection devices to report properly. This setting delays when the Needle and Loper Thread Breaks become active.

Limits: Minimum - 0 Maximum - 5.0 Default - 1.0
Unit of Measure - Seconds

Thread Break Debounce

When the machine is not running the Thread Break eyes are dark as in an actual Thread Break condition. Therefore, Needle and Loper Thread Breaks are not active until the machine has been running for the time set by the Thread Break Enable Delay setting. During the process of sewing the needle and looper thread may loosen or tighten causing the Thread Break Detect eyes to go dark. The Thread Break Debounce gives the thread time to "settle down" in order to report an actual thread break. If this number is set too low you may get false thread break errors. Conversely, if set to high, several stitches may pass before the operator is alerted.

Limits: Minimum - 0 Maximum - 5.0 Default - 1.0
Unit of Measure - Seconds

Undertrimmer Delay

The Undertrimmer is the knife mechanism under the needle plate that trims the needle thread when needed. The Undertrimmer activates during a jump move in a Sew and Jump pattern. During the jump portion of a Sew and Jump pattern, the machine stops after it has moved the Needle Tail Length distance. The machine then stops to allow for the Undertrimmer to activate. The Undertrimmer Delay is the amount of time the jump move is delayed to allow the Undertrimmer to cut the needle thread. Once undertrimming is complete the machine continues the jump move.

Limits: Minimum - 1.00 Maximum - 4.00 Default - 2.00
Unit of Measure - Seconds

Foot Height High Limit

The maximum RPM allowed with the foot in the High position.

Limits:
Minimum - 0
Maximum - 1275
Default - 500

Unit of Measure - RPM

Foot Height Medium Limit

The maximum RPM allowed with the foot in the Medium position.

Limits:

Minimum - 0

Maximum - 1275

Default - 500

Unit of Measure - RPM

Panel Cutter Error Delay

The amount of time from when the Panel Cutter sensor is covered till an error is displayed.

Limits:

Minimum - 0

Maximum - 60

Default - 10

Unit of Measure - Seconds

File Directory Defaults

As seen in the Copy Pattern Files section, new patterns have to be copied to the PC running the quilter in order to be used. If you normally copy from (Source) and/or to (Destination) the same places you can set the defaults (shown above) so that any time the Copy Pattern Files section is accessed it will be pre-populated with the appropriate data and Browsing will not be necessary.

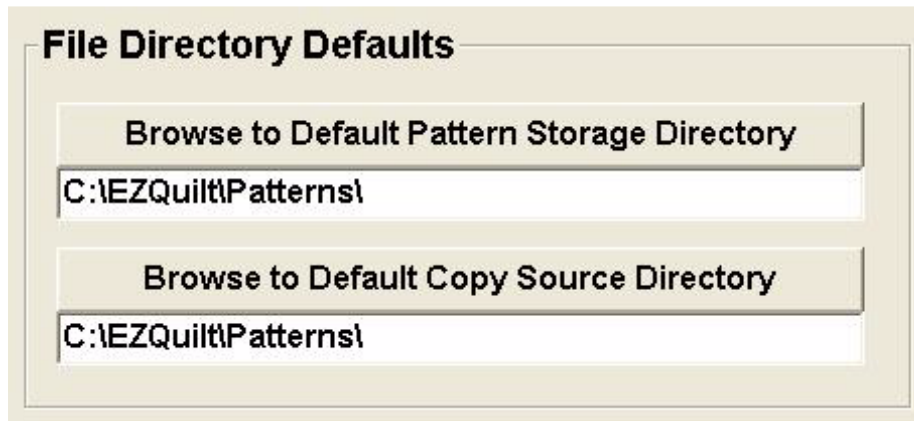

Miscellaneous Operations

Continuous Bearing Lubrication is used to prime or purge the lubrication lines. Clicking the Continuous Bearing Lubrication button continually pumps lubricant to the machine until the button is pressed again to turn it off.



Efficiency Statistics

Efficiency Statistics are calculated based on the amount of time the machine is in Run Mode (sewing) divided by the amount of time the machine is turned on.

Time Display changes the format the On and Run times are displayed in.

The Last Reset box displays the last time the Reset button was pressed resetting the On and Run Times to 0 (zero).

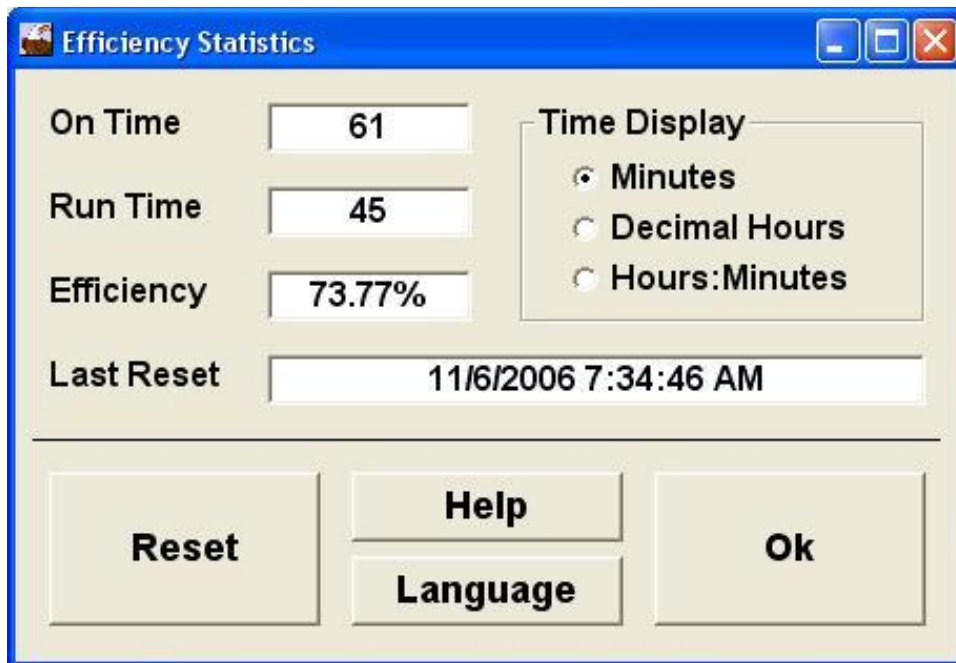

The screenshot shows a dialog box titled "Efficiency Statistics" with a blue title bar and standard window controls (minimize, maximize, close). The dialog contains several input fields and a radio button group. The "On Time" field shows "61", "Run Time" shows "45", and "Efficiency" shows "73.77%". The "Time Display" section has three radio buttons: "Minutes" (selected), "Decimal Hours", and "Hours:Minutes". The "Last Reset" field shows "11/6/2006 7:34:46 AM". At the bottom, there are three buttons: "Reset", "Help", and "Ok". The "Language" button is positioned below the "Help" button.

On Time	61	Time Display <input checked="" type="radio"/> Minutes <input type="radio"/> Decimal Hours <input type="radio"/> Hours:Minutes
Run Time	45	
Efficiency	73.77%	
Last Reset	11/6/2006 7:34:46 AM	

Buttons: Reset, Help, Language, Ok

Assembly Drawings & Parts Lists

The materials contained herein are confidential and proprietary information of Atlanta Attachment Company. In addition to any confidentiality and non-disclosure obligations that currently exist between you and Atlanta Attachment Company, your use of these materials serves as an acknowledgment of the confidential and proprietary nature of these materials and your duty not to make any unauthorized use or disclosure of these materials.



One-Stop Shopping
For Expendable Replacement Parts for AAC & Other Bedding Equipment Suppliers
Toll Free: **1-866-885-5100**
www.atlantapartsdepot.com • sales@atlantapartsdepot.com

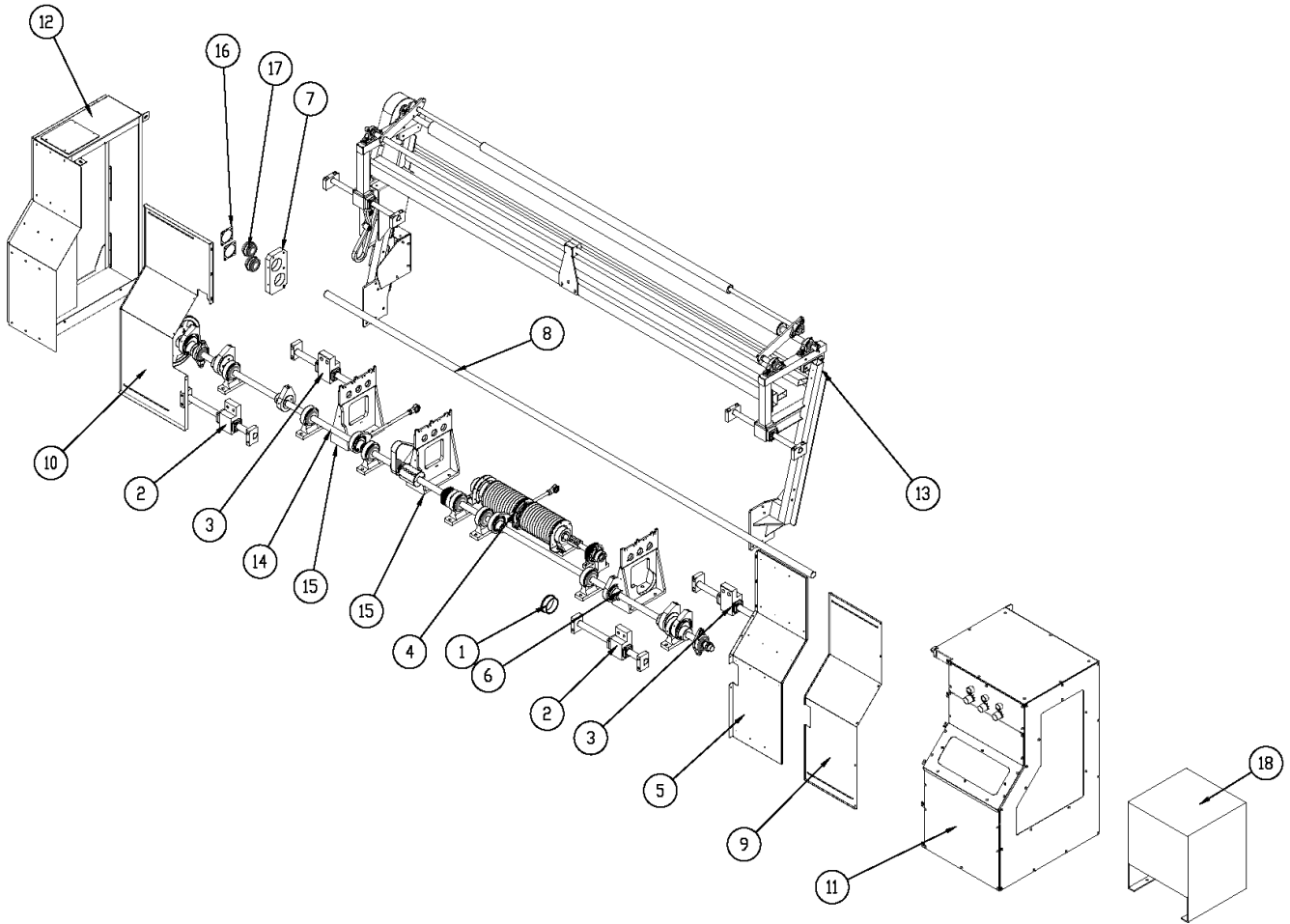

11392D Quilter, Golden Eagle, HD

AAC Drawing Number 9000928 Rev 5

NO.	QTY	PART#	DESCRIPTION	NO.	QTY	PART#	DESCRIPTION
1	1	5-035	COLLAR	10	1	1389288	COVER,PANEL,BENT,R
2	2	1388222	LINEAR SLIDE,FT,35MM	11	1	1389353	GUARD,MOTOR ASM
3	2	1388227	LINEAR SLIDE,RR,35MM	12	1	1389384	LEFT GUARD ASSY
4	1	1388673	DRIVE, 12 IN LEADSCREW	13	1	1389697	TRANSFER CARRIAGE ASSY
5	1	1389223	GUARD,PANEL,LEFT	14	1	1389815	MAIN DRIVE SHAFT ASM,D
6	1	1389240	SUPPORT, THROAT PLATE	15	2	1389893	SUPPORT, THROAT PLATE
7	1	1389268	BLOCK,BRG MTG,FLG	16	2	1393993	RETAINER, CARTRIDGE BRG
8	1	1389269	SHAFT, 40MM, PRESSER	17	2	BBER208TMC	BEARING,INSERT,SKWEZLOC
9	1	1389287	PANEL,BENT,R	18	1	FFDTFA0142S	TRANSFORMER,DRIVE

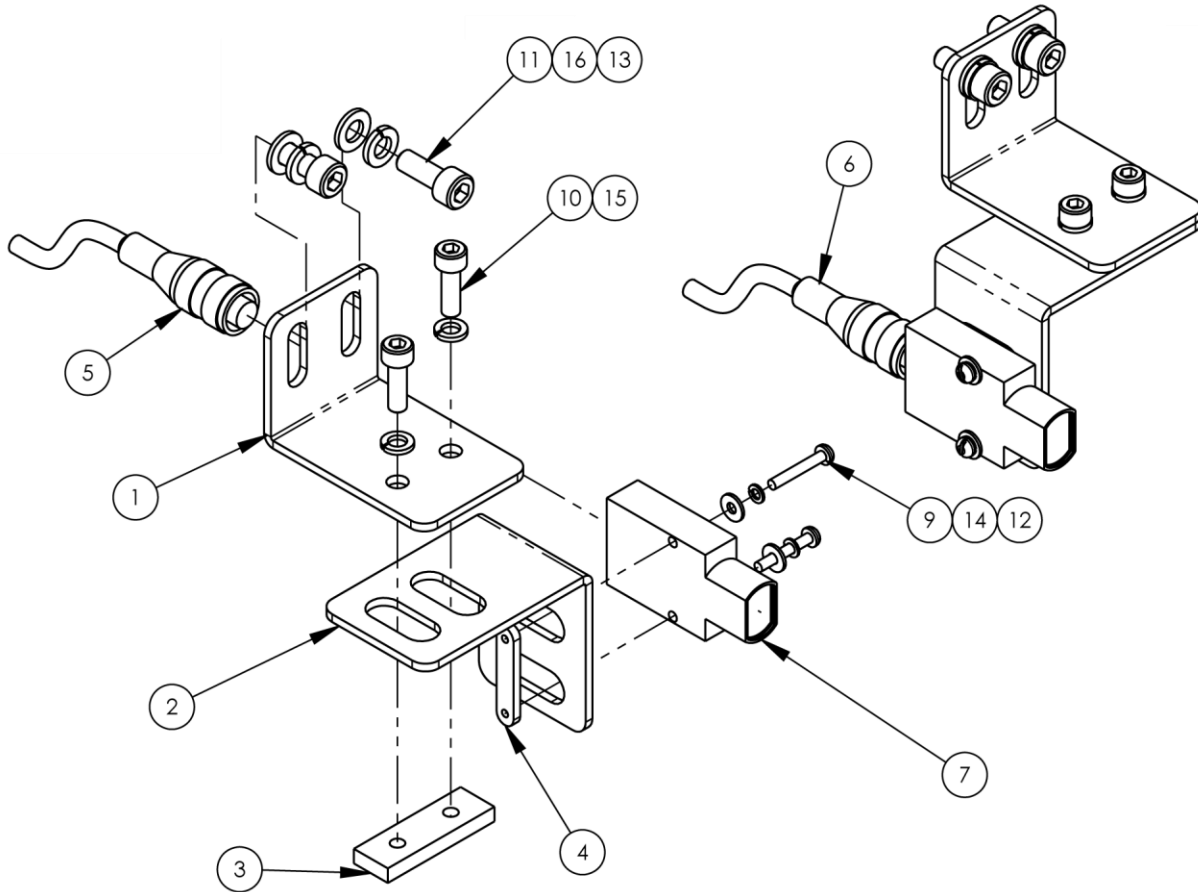

1389234 Panel Eye Cutter Assembly

AAC Drawing Number 1389234 Rev 1

NO.	QTY	PART #	DESCRIPTION
1	2	1389231	BRKT,UPPER,PC OK EYE
2	2	1389232	BRKT,LOWER,PC OK EYE
3	2	1389233	PLATE,NUT,M5@2X20MM
4	2	1975-412A	PLATE,NUT,4-40,.95CTC
5	1	FFRK44T-4	CABLE,EYE,12',NO END
6	1	FFRK44T-6	CABLE,EYE,19',NO END
7	2	FFSM312LVQ	EYE,ELECTRIC,10-30VDC
8	12 in	MMT9945	TAPE,REFLECTIVE,2" WIDE
9	4	SSPS70048	4-40 X 3/4 PAN HD SLOTTED
10	4	SSSCM5X16	M5-0.8 X 16 SOC CAP
11	4	SSSCM6X16	M6-1.0 X 16 SOC CAP
12	4	WWF4	WASHER, FLAT #4
13	4	WWFM6	6MM FLAT WASHER
14	4	WWL4	#4 LW
15	4	WWLM5	M5 LOCK WASHER
16	4	WWLM6	M6 LOCK WASHER

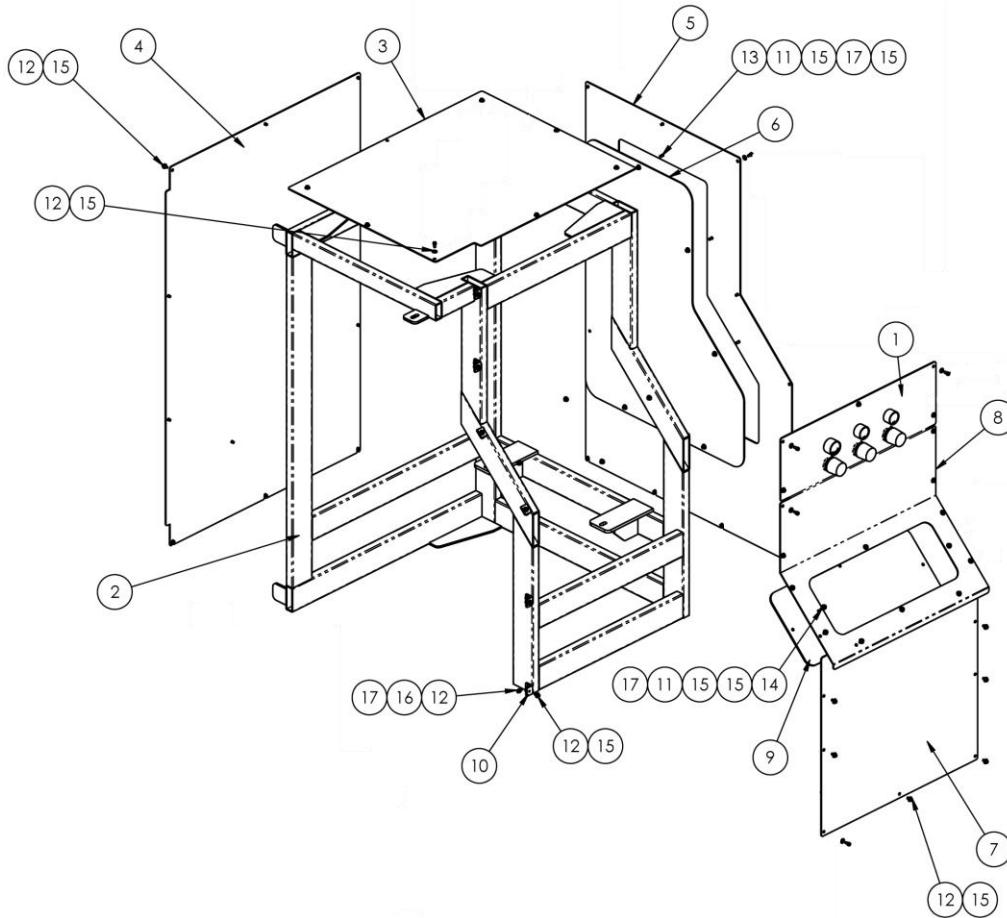

1389353 Motor Guard Assembly

AAC Drawing Number 1389353 Rev 3

NO.	QTY	PART #	DESCRIPTION
1	1	1389183	REGULATOR ASSY
2	1	1389355	WELDMENT, GUARD
3	1	1389361	PANEL, TOP, MOTOR GUARD
4	1	1389362	PANEL, BACK MOTOR GUARD
5	1	1392404	PANEL, SIDE MOTOR GUARD
6	1	1392551	LEXAN FOR 1392404
7	1	1392631	PANEL, LOWER, MTR GUARD
8	1	1392632	PANEL, FRONT, CABINET
9	1	1392634	WINDOW, TOP
10	6	1392738	CLIP, PANEL
11	12	NNHM5X0.8	NUT, HEX, M5-0.8
12	72	SSSCM5X10	SCREW, SOC CAP, M5-0.8 X 10
13	7	SSSCM5X14	SCREW, SOC CAP, M5-0.8 X 14
14	4	SSSCM5X16	M5-0.8X16, SCREW, SOCKET CA
15	82	WWF10	WASHER, FLAT, #10, COM
16	12	WWFM5	WASHER, FLAT, M5 I.D.
17	23	WWL10	WASHER, LOCK, #10, S/S

Page 129

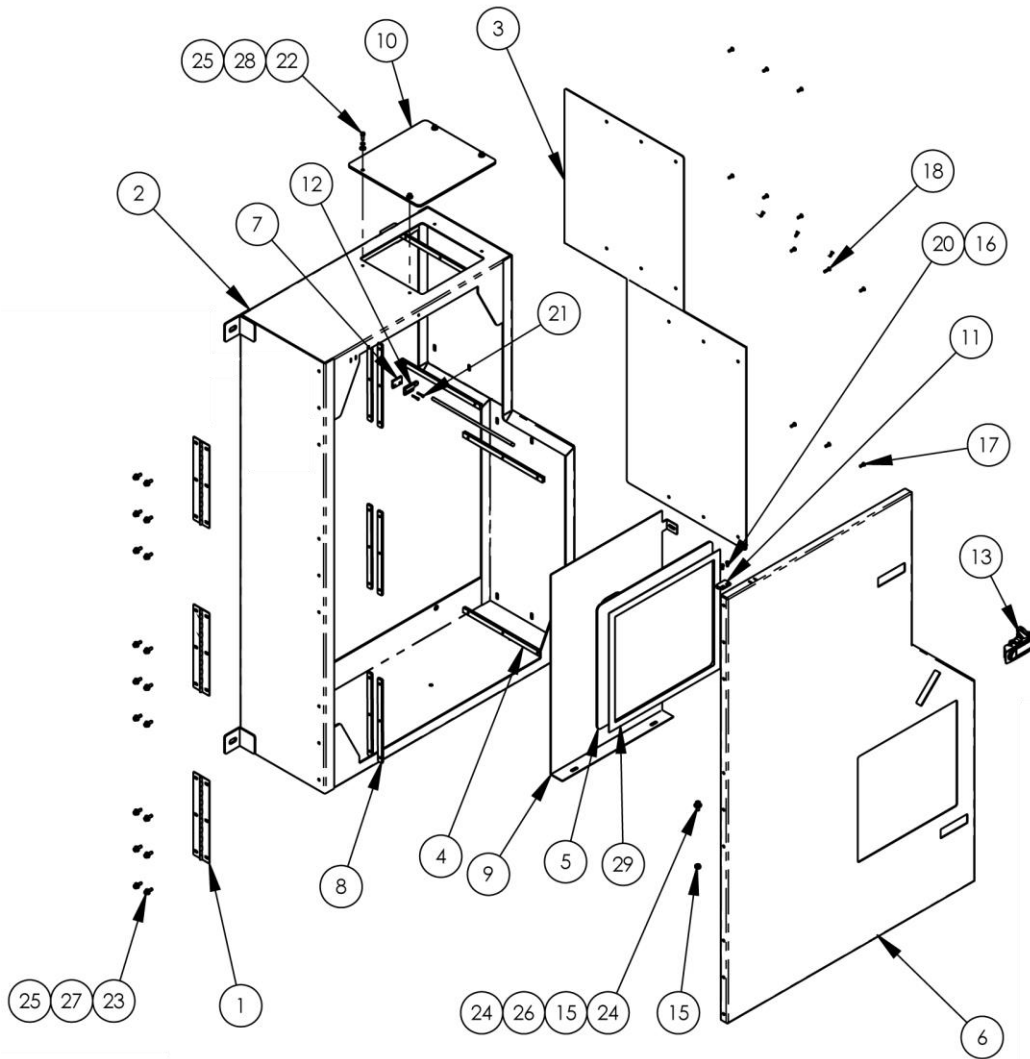

1389384 Left Guard Assembly

AAC Drawing Number 1389384 Rev 2

NO.	QTY	PART #	DESCRIPTION	NO.	QTY	PART #	DESCRIPTION
1	3	1337-4217	PIANO HINGE 2W OPEN	16	4	NNH4-40	#4-40 HEX NUT
2	1	1389278	WELDMENT, GUARD, LEFT	17	14	SSFCM4X12	M4-0.7X12 FLAT ALLEN
3	1	1389289	PANEL, BENT, L	18	1	SSFCM4X16	M4-0.7 X 16 FLAT ALLEN
4	5	1389349	NUT PLATE, FRONT LEFT COVE	19	2	SSSC01040	1/4-20 X 5/8 SOC CAP
5	1	1389350	WINDOW, HAND WHEEL, LEFT	20	2	SSSC70024	#4-40 X 3/8 SOC CAP
6	1	1389352	COVER, GUARD, LH	21	2	SSSC70040	#4-40 X 5/8 SOC CAP
7	1	1389391	SPACER, DOOR SWITCH	22	4	SSSCM5X14	SCREW, SOC CAP, M5-0.8 X 14
8	6	1389401	NUT PLATE, DOOR HINGE	23	18	SSSCM5X16	M5-0.8 X 16 SOC CAP
9	1	1389779	PLATE, LABEL MTG	24	2	WWFS1/4	WASHER FLAT, 1/4
10	1	1389816	COVER, TOP, LEXAN	25	22	WWFS10	WASHER, FLAT, #10, SAE
11	1	FF57105000	REED SWITCH MAGNET, FLANGE	26	2	WWL1/4	1/4 LW
12	1	FF59105010	REED SWITCH, FLANGE, N.O	27	18	WWL10	#10 LW
13	3	MMC23315	LATCH, LEVER, ADJUSTABLE	28	4	WWLM5	M5 LOCK WASHER
14	*155	MMLSSBB01210	FOAM, URETHANE, 1/8X1	29	*56	ZZZSH-310	TAPE, DOUBLE SIDED, 3/4"W
15	2	NNH1/4-20	1/4-20 HEX NUT				

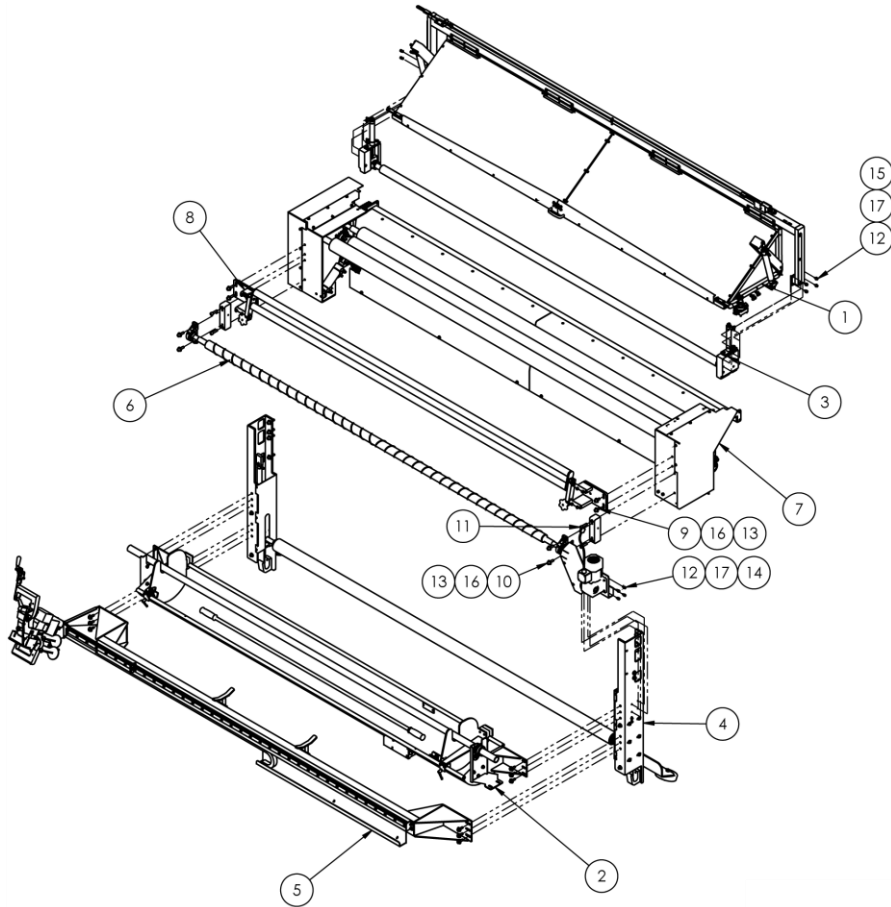

1389533 Front End Assembly

AAC Drawing Number 1389533 Rev 1

NO.	QTY	PART #	DESCRIPTION
1	1	1388560	FRONT GUARD ASSY,1392B
2	1	1392087	TRAY ASSEMBLY, FRONT
3	1	1392306	ROLLER LIFT ASSEMBLY
4	1	1392448	TENSION ROLLER ASSEMBLY
5	1	1392580	BAG CLOSING MOUNT ASM
6	1	1392897	PLEAT PREVENTION ASM
7	1	1392978	FRONT FEED ASSY.
8	1	1393922	TENSIONER ASSEMBLY
9	2	SSSCM10X25	10M X 25MM, SOC CAP
10	4	SSSCM10X35	CAP SCREW 10MM X 35MM
11	6	SSSCM10X40	CAP SCREW 10MM X 40MM
12	12	SSSCM6X15	M6X15 SOC CAP SCREW
13	8	WWFM10	WASHER, FLAT, M10 I.D.
14	8	WWFM6	WASHER, FLAT, M6, SAE
15	4	WWFM6.1	WASHER, FLAT, M6, SAE
16	8	WWLM10	M10 LOCK WASHER
17	12	WWLM6	M6 LOCK WASHER

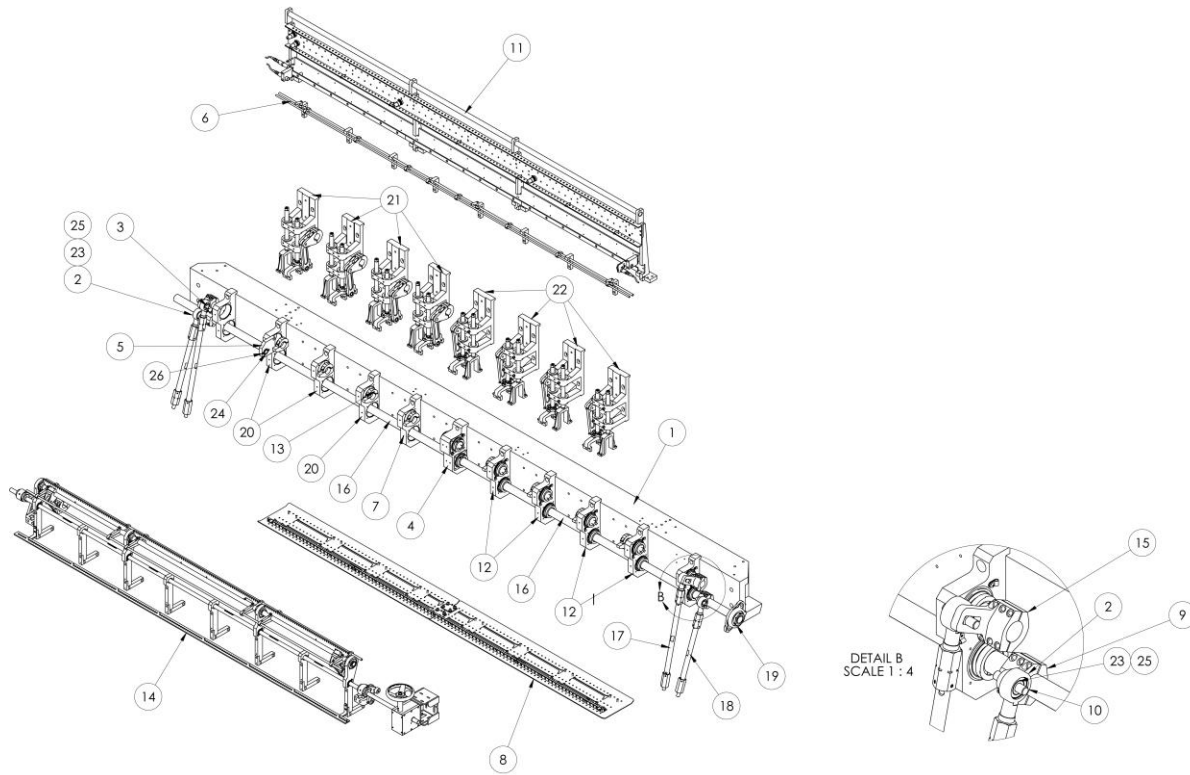

1389534 Bridge Assembly

AAC Drawing Number 1389534 Rev 3

NO	QTY	PART #	DESCRIPTION	NO	QTY	PART #	DESCRIPTION
1	1	1-006C	TOP BRIDGE BEAM	14	1	1393864	FOOT ADJUSTMENT ASSY
2	4	1-008	ROD END HOUSING	15	2	1393867	P.FOOT SHAFT LEVER
3	2	1-009A	PIVOT SHAFT, THREADED PIN	16	2	1393978	40MM SHAFT, NEEDLE BAR
4	1	1389023	MOUNT,INSERT BRG,ASM,CTR	17	2	1393983	TIE ROD ASSEMBLY,PFOOT
5	1	1389026	SUPPORT,ADJ FOOT SHAFT	18	2	1393986	TIE-ROD ASSEMBLY,NDL
6	1	1389073	ADJ NDL THD TAKEUP ASBLY	19	1	1393987	BEARING,FLANGE,2BOLT
7	1	1389246	MOUNT,INSERT BRG,LH,SPEC	20	4	1393994	MOUNT,INSERT BRG,ASM, LH
8	1	1389509	PRESSER FEET AND NDL BARS	21	4	1393998	DRIVE,NDL & PS FT ASM LT
9	2	1389704	NDL SHAFT LEVER	22	4	1393999	DRIVE,NDL & PS FT ASM RT
10	2	1389705	PIN,PIVOT,NDL DRIVE LEVER	23	4	BB63032RS	BEARING, RADIAL SEALED
11	1	1392124	NEEDLE THREAD MOUNT ASM	24	1	BBGE20ES2RS	BEARING,SPHERICAL PLAIN,2
12	5	1393748	MOUNT,INSERT BRG, ASM, RH	25	4	MM98409A244	E-RING, INT, 1-7/8 X .068
13	8	1393749	CAM, PRESSER FOOT DRIVE	26	2	SSBCM5X8	SCREW,BUTTON CAP

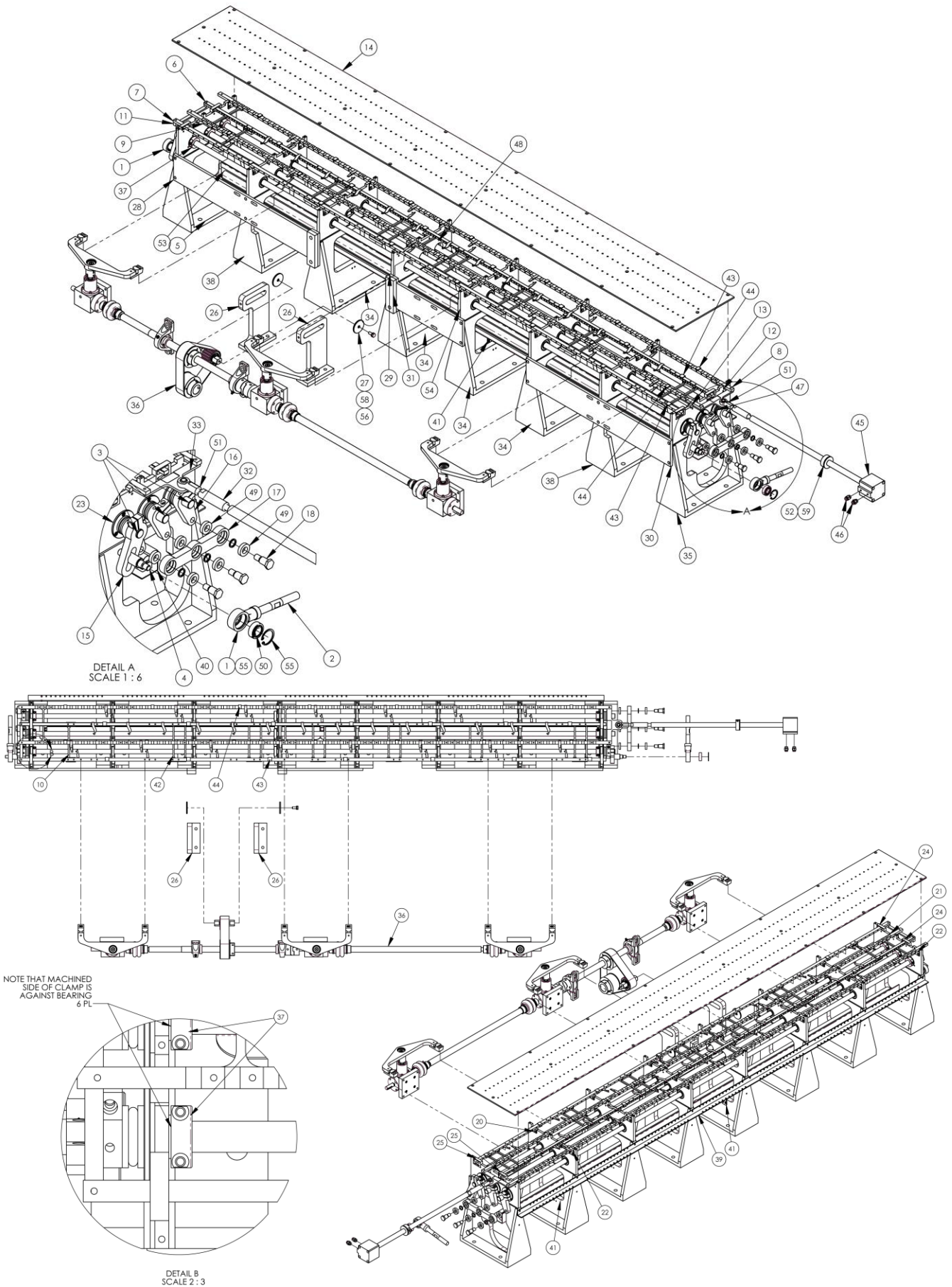

1389566 Throat Plate Assembly

AAC Drawing Number 1389566 Rev 7

NO	QTY	PART #	DESCRIPTION	NO	QTY	PART #	DESCRIPTION
1	2	1-017	ROD END, PRESSER FOOT	31	2	3-036	BLOCK,BEARING
2	2	1-028	LOOPER DRIVE PITMAN ROD	32	1	4-013A	ROD EXTENSION,KNIFE CYL
3	3	1-029	SHAFT,LOOPER,20MM	33	1	4-014A	FORK,KNIFE BAR,MODOFIED
4	2	1-037	LOOPER DRIVE LINK, 83 MM	34	4	1388704	SUPPORT, THROAT PLATE
5	1	2-001A	SUPPORT, THROAT PLATE	35	1	1389240	SUPPORT, THROAT PLATE,SPE
6	1	2-003	BAR,RETAINER MTG,REAR	36	1	1389495	RETAINER DRIVE ASBLY
7	1	2-004	BAR,RETAINER MTG,FRONT	37	6	1389524	CLAMP COLLAR,M20,W/SHLDR
8	2	2-005	BAR,KNIFE MTG	38	2	1389893	SUPPORT, THROAT PLATE,SPE
9	2	2-006	LINK,KNIFE BAR	39	1	1392170	GUIDE, LOOPER THREAD ASM
10	2	2-007	LINK,RETAINER,SINGLE	40	2	1392576	REFLECTOR, GOLDEN EAGLE
11	1	2-008	LINK,END,RETAINER BAR	41	4	1392748	BRACKET,LIGHT
12	1	2-012	GUIDE,KNIFE RAIL,RIGHT	42	5	1392807	LINK, RETAINER,DOUBLE
13	1	2-013	GUIDE, KNIFE RAIL,RIGHT	43	14	1392810	GIB, RETAINER BAR, FRONT
14	1	2-19A	NEEDLE PLATE	44	14	1392812	GIB, KNIFE BAR
15	2	2-024	ROCKER, LOOPER DRIVE	45	1	AACQGY50X25	CYL,AIR, 1392 TRIMMER
16	6	2-026	CRANK,LOOPER	46	2	AAQMC-4-4U	QU MALE CONN,1/4X1/4PT
17	2	2-027	LINK,LOOPER CRANK	47	6	BB51204J	THRUST BEARING
18	6	2-028	PIN,THREADED,LOOPER CRANK	48	24	BB60042RS	BEARING,BALL,20 ID,42 OD
19	6	2-029	SPACER,RING,15MM ID,2MMTK	49	12	BB61902	BEARING,BALL,15MM BORE
20	12	2-037	PAD,WEAR, RETAINER	50	2	BB62022RS	BEARING, RADIAL, SEALED
21	7	2-039-1	GUIDE,KNIFE RAIL,CENTER	51	1	BBAGM10Z	BEARING,ROD END,10MM FEM
22	7	2-040-1	GUIDE,KNIFE RAIL,REAR	52	1	CCCLM20F	CLAMP COLLAR- M20
23	6	2-054A	COVER, BEARING, LOOPER	53	2	HLES46BCCW	FLOURESCENT FIXTURE 48"
24	2	2-066	SLEEVE, RETAINER,LEFT	54	1	HLSDCHL	DIRECT CONN,SLIMLITE XL
25	2	2-066-3	SLEEVE, RETAINER,RIGHT	55	2	MMH0137	SNAP RING,INTERNAL
26	2	3-025	BRACKET, PULLEY, RETAINER	56	1	SSHCM8X20	SCREW,HEX CAP
27	1	3-026	WASHER, PULLEY	57	6	WWFM4.3	WASHER, FLAT, M4
28	1	3-033	PLATE, GEARBOX MOUNT	58	1	WWLM8	M8 LOCK WASHER
29	1	3-034	PLATE, GEARBOX MOUNT	59	1	WWU20MM	WASHER,URETHANE,20MM ID
30	1	3-035	PLATE, GEARBOX MOUNT				

60	*	2-009	Retainer, Outside
61	*	2-010	Retainer, Inside
62	*	2-032	Cutter, Thread

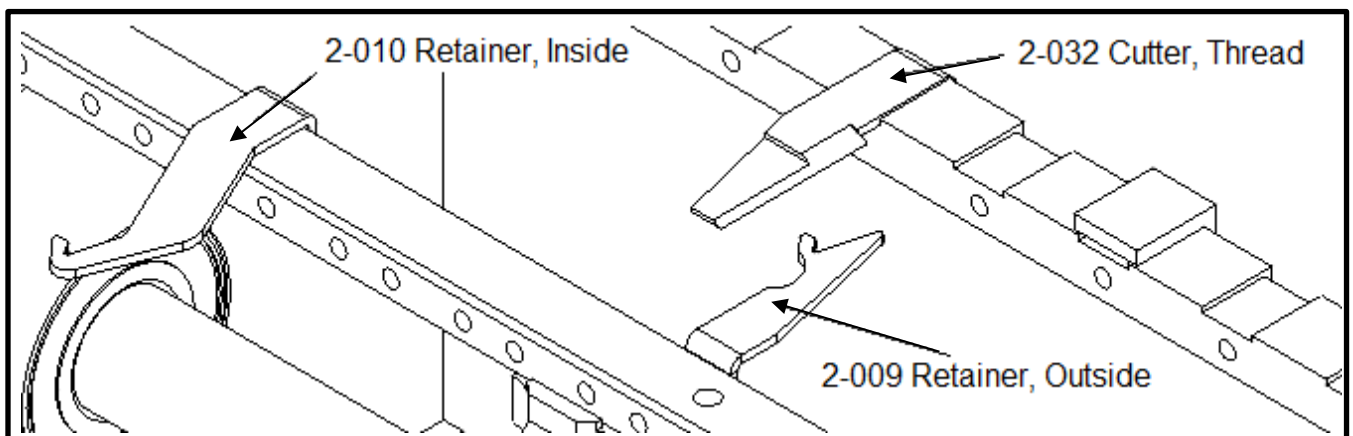

1389556 Base Assembly w/ Motors

AAC Drawing Number 1389556 Rev 2

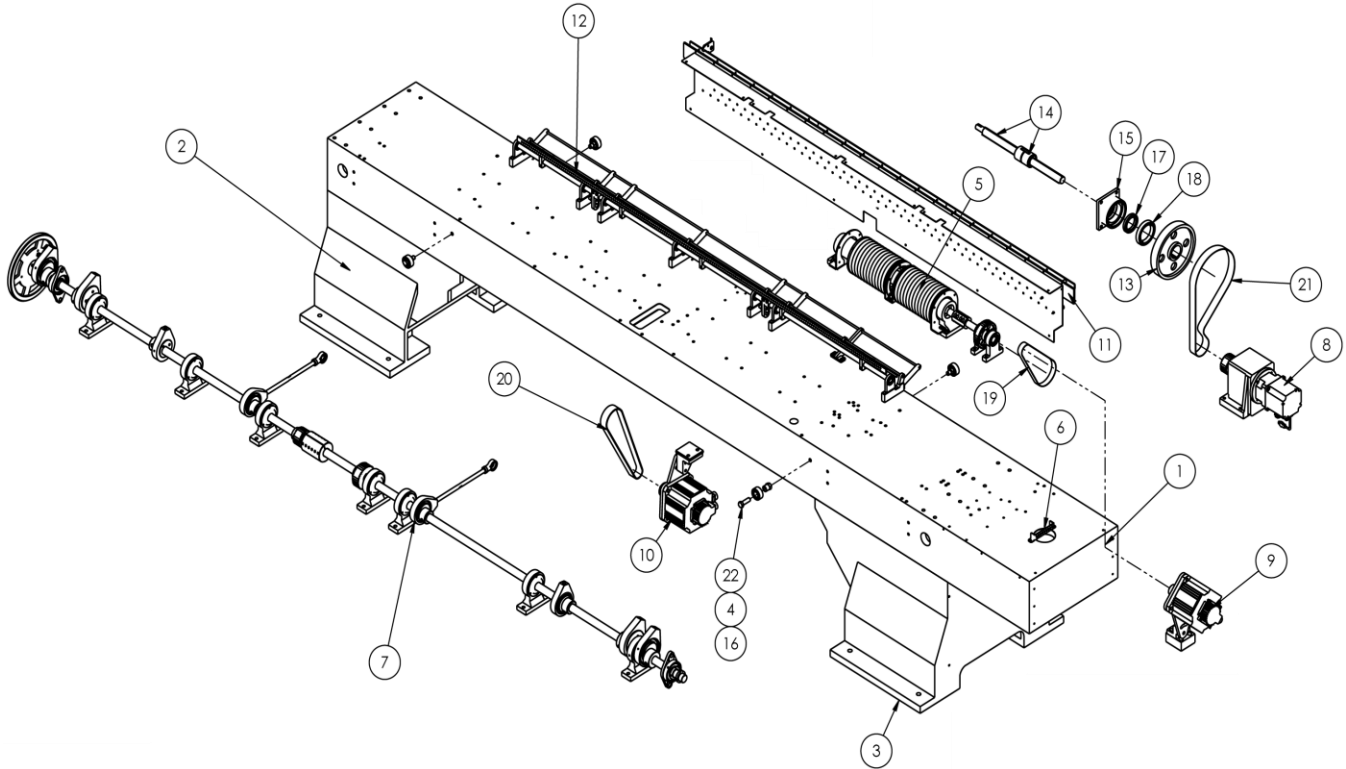

NO.	QTY	PART #	DESCRIPTION
1	1	1-001	BASE, QUILTER
2	1	1-002	LEFT BASE
3	1	1-003	RIGHT, BASE FOOT
4	4	1-007	MT,BEARING,ECCENTRIC
5	1	1388673	DRIVE, 12 IN LEADSCREW
6	1	1389033	BRKT,STRAIN RELIEF
7	1	1389815	MAIN DRIVE SHAFT ASM,D
8	1	1392070	ROLL SERVO DRIVE ASM
9	1	1392071	CARRIAGE SERVO DRIVE ASM
10	1	1392082	NEEDLE BAR DRIVE ASM
11	1	1392125	REAR THREAD TENSION ASM
12	1	1392196	TAKE-UP, LOOPER ASM
13	1	2-047	GEAR PULLEY, 84 TOOTH
14	1	2-50A	SHAFT,SPLINE,Y AXIS
15	1	4-045A	HOUSING, BEARING
16	4	BB32052RS	BEARING,2 ROW,25MM X 52MM
17	1	BB69122RS	BEARING, RADIAL,SEALED
18	1	BB69162RU	BEARING, RADIAL SEALED
19	1	GG300L100	BELT, TIMING, L-TYPE
20	1	GG405L150	BELT, TIMING, L-TYPE
21	1	GG510L150	BELT, TIMING, L-TYPE
22	4	SSHCM16X50	SCREW,HEX CAP

Page 121

Page 122

Page 123

Page 124

Page 125

Page 126

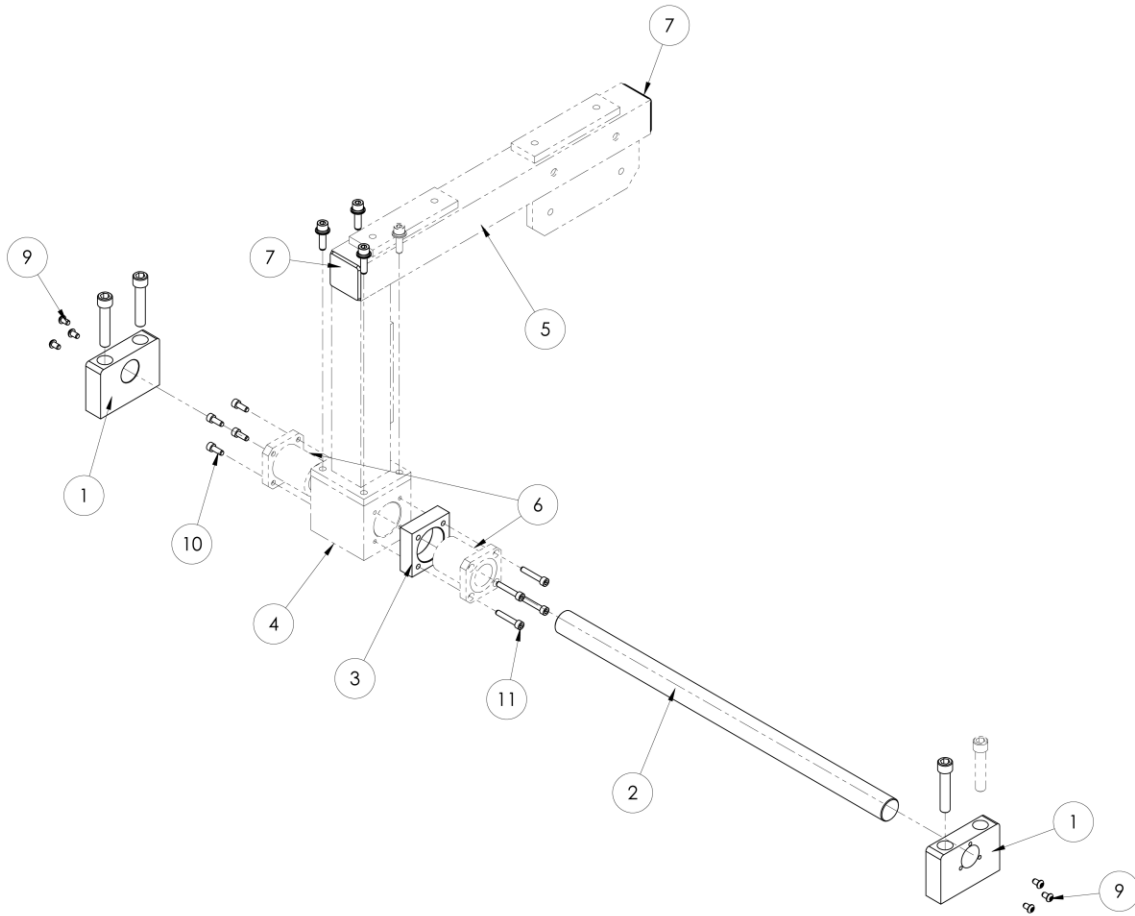

1389238 Transfer Carriage Rail

AAC Drawing Number 1389238 Rev 2

NO	QTY	PART #	DESCRIPTION
1	2	1389235	BRKT,SLIDE SUPPORT
2	1	1389237	SHAFT,SLIDE
3	1	1389239	SPACER, BEARING
4	1	1392013	BLOCK,SLIDE
5	1	1392016	WELDMENT,ROLLER SUPPORT
6	2	BBSMK30GUU	BEARING,LIN,FLG,30MM
7	2	MM132-2X2	END CAP, SQUARE, 2X2
8	3	SSSCM12X60	SCREW, M12 X 50
9	6	SSBCM6X10	SCREW,SOCKET CAP
10	4	SSSCM6X16	M6 X 16, SOC CAP
11	4	SSSCM6X35	M6X30 SOC CAP SCREW
12	3	SSSCM8X30	SCREW,SOC CAP,M8X30
13	3	WWFS5/16	WASHER,FLAT,SAE,5/16
14	3	WWL5/16	WASHER,LOCK, 5/16

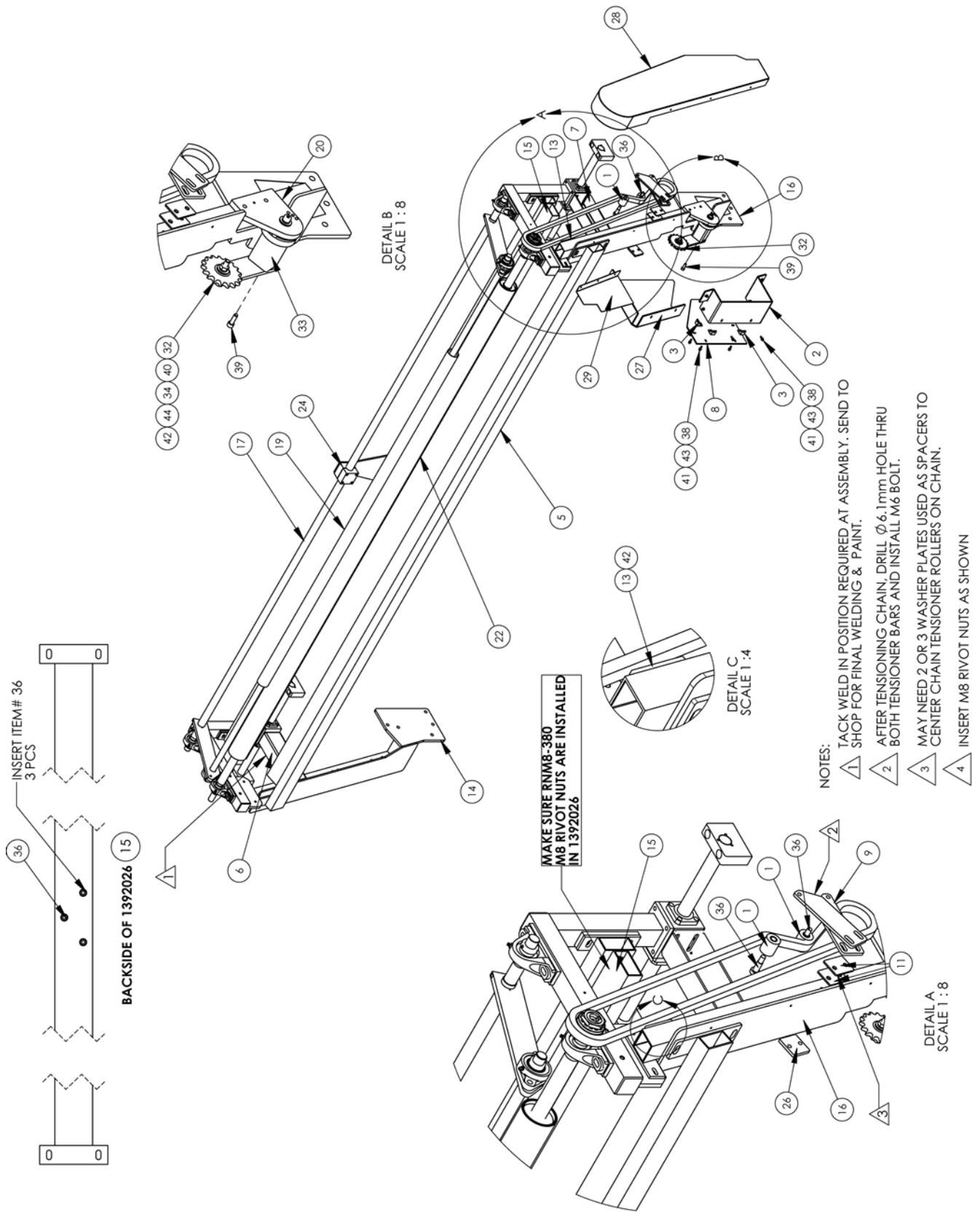

1389697 Transfer Carriage Assembly

AAC Drawing Number 1389697 Rev 6

NO	QTY	PART	DESCRIPTION
1	2	1388799	ROLLER,CHAIN TENSIONER
2	1	1389047	GUARD,BELT,BOTTOM
3	4	1389053	CLIP, GUARD MTG
4	2	1389238	TRANSFER CARRIAGE RAIL
5	1	1389447	BRACE WELDMENT,CARRIAGE
6	1	1389502	BRACE,RH
7	1	1389503	BRACE,LH
8	1	1389523	GUARD,BELT,BOTTOM
9	2	1389574	BAR,CHAIN TENSIONER
10	1	1389575	TORQUE LIMIT ASSY,50A17
11	2	1389586	PLATE,WASHER
12	1	1389603	CHAIN,#50 X 81.875"
13	1	1389820	BLOCK,RUB
14	1	1392020	STRUT WELDMENT,RH
15	1	1392026	BRACE WELDMENT
16	1	1392027	STRUT WELDMENT,LH
17	1	1392034	SHAFT ASSY
18	2	1392035	ARM,W EIGHTED ROLL
19	1	1392114	ROLLER,50 X 2900
20	1	1392146	PLATE,TENSIONER MTG
21	2	1392147	SHIM,TENSIONER
22	1	1392343	WELDMENT,FW D CARRIAGE ROL
23	1	1392533	PLATE,BRACE MTG
24	1	1392534	BLOCK, STABLIZER
25	1	1392672	KEY,7MMX8MMX.96 IN
26	1	1393467	PLATE,NUT,M8
27	1	1393660	GUARD,BELT,INSIDE
28	1	1393887	BELT GUARD
29	1	1393962	BELT GUARD
30	2	BBNANFL205-25	BEARING,2-BOLT FLG,25MM
31	4	BBNAP205-25	BEARING, PILLOW BLOCK
32	1	MM50X17BB	SPROCKET,BALL BEARING
33	1	MMSE27	TENSIONER,DRIVE
34	1	NNHM10X1.5	NUT,HEX,M10X1.5
35	3	RNM8-380	NUT,RIVET,M8-1.25
36	2	SSAS12X25X10	SHOULDER BOLT M10-1.5x12
37	2	SSSCM5X12	M5 X 12 SOC CAP SC
38	11	SSSCM5X16	M5-0.8X16,SCREW ,SOCKET CA
39	1	SSSCM8X25	SCREW ,SOC CAP,M8X25
40	2	SSSCM10X50	CAP SCREW 10MM X 50MM
41	11	W WFM5	W ASHER, FLAT, M5 I.D.
42	3	W WFS1/2	W ASHER,FLAT,1/2, SAE
43	11	W WLM5	M5 LOCK W ASHER
44	2	W WLM10	M10 LOCK W ASHER

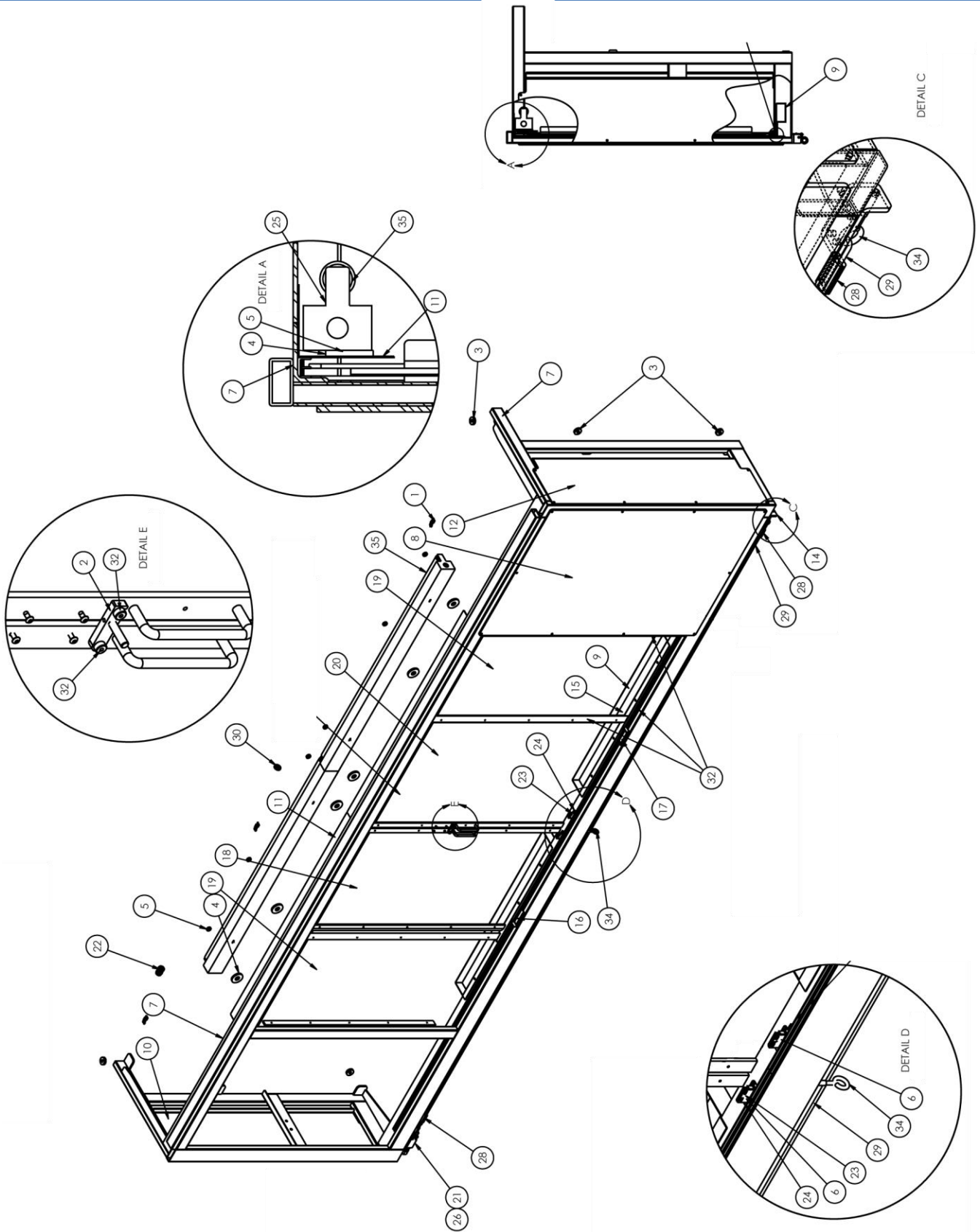

1392185 Rear Closure Assembly

AAC Drawing Number 1392185 Rev 18

NO.	QTY	PART #	DESCRIPTION
1	3	1388150	CLIP, DOOR TRACK, 1392
2	1	1388189	LATCH, SLIDING DOOR, 1392
3	6	1388675	WASHER, REAR CLOSURE
4	6	1389207	CUSHION, RUBBER, 2 OD X 1/4
5	6	1389208	SPACER, LIGHT MTG
6	2	1389213	SPACER, .09 THK
7	1	1392180	REAR CLOSURE WELDMENT
8	2	1392186	FIXED FRONT WINDOW
9	2	1392309	TOOL TRAY, 1.5X3X36
10	1	1392461	COVER, LEXAN, 380X1106
11	2	1392464	REFLECTOR, 4'
12	1	1392470	COVER, LEXAN, 380X1106
13	1	1392530	BRACKET, SAFETY SWITCH
14	1	1392532	BRKT, EYEBOLT MTG
15	2	1392725	FOAM, NONSLIP, 3" X 36"
16	1	1392993	STOP, DOOR, LH
17	1	1392995	STOP, DOOR, RH
18	1	1393819	ASSY, WINDOW LARGE LFT
19	2	1393820	ASSY, WINDOW SMALL
20	1	1393821	ASSY, WINDOW LARGE RT
21	1	EEPS21RNN7TK0	SWITCH, SAFETY, CABLE PULL
22	1	FF3216	STRAIN RELIEF, LIQ TIGHT
23	2	FF57105000	REED SWITCH MAGNET, FLANGE
24	2	FF59105010	REED SWITCH, FLANGE, N.O
25	2	FFM1414	FIXTURE, LIGHT, 4'
26	1	FFM4518	STRAIN RELIEF, LIQ TIGHT
27	2	MM1717A3	TRACK, DOOR, SET, TOP & BOTTOM
28	2	MM3471T23	CLAMP, ROPE, WIRE, 3/16", STEEL
29	15'	MM8923T81	ROPE, WIRE, SS, 3/16", RED
30	1	MM9600K36	GROMMET, RUBBER, 9/16 ID
31	8	MMFELTSTRP	FELT, STRIP, FIDEL, 4" WIDE
32	2	SSAS016016	SHOULDER BOLT #10 X .375T
33	4	SSBC80032	6-32 X 1/2 BUT HEAD
34	2	SSBE10160	EYEBOLT, 5/16-18X2.5
35	2	ZZZMT-115	BULB, 4' FLUORESCENT

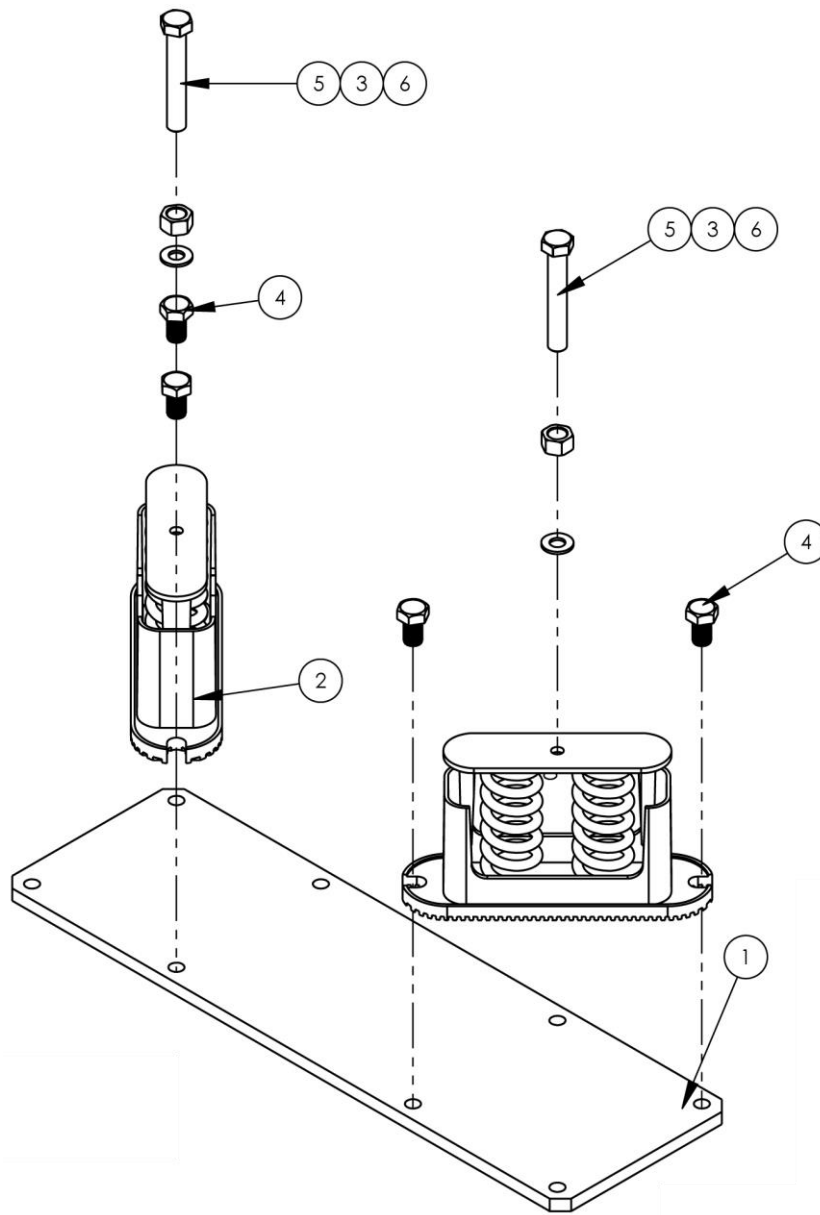

1389740 Isolator Base Assembly

AAC Drawing Number 1389740 Rev 1

NO.	QTY	PART #	DESCRIPTION
1	1	1389739	BASE, ISOLATOR
2	2	MMCE235	VIBRATION ISOLATOR, SPRING
3	2	NNH5/8-11	NUT, HEX, 5/8-11
4	4	SSH41064	5/8-11 X 1 HEX CAP SCREW
5	2	SSH41256F	5/8-11X4 HEX CAP FULL THD
6	2	WWFS1/2	WASHER, FLAT, 1/2

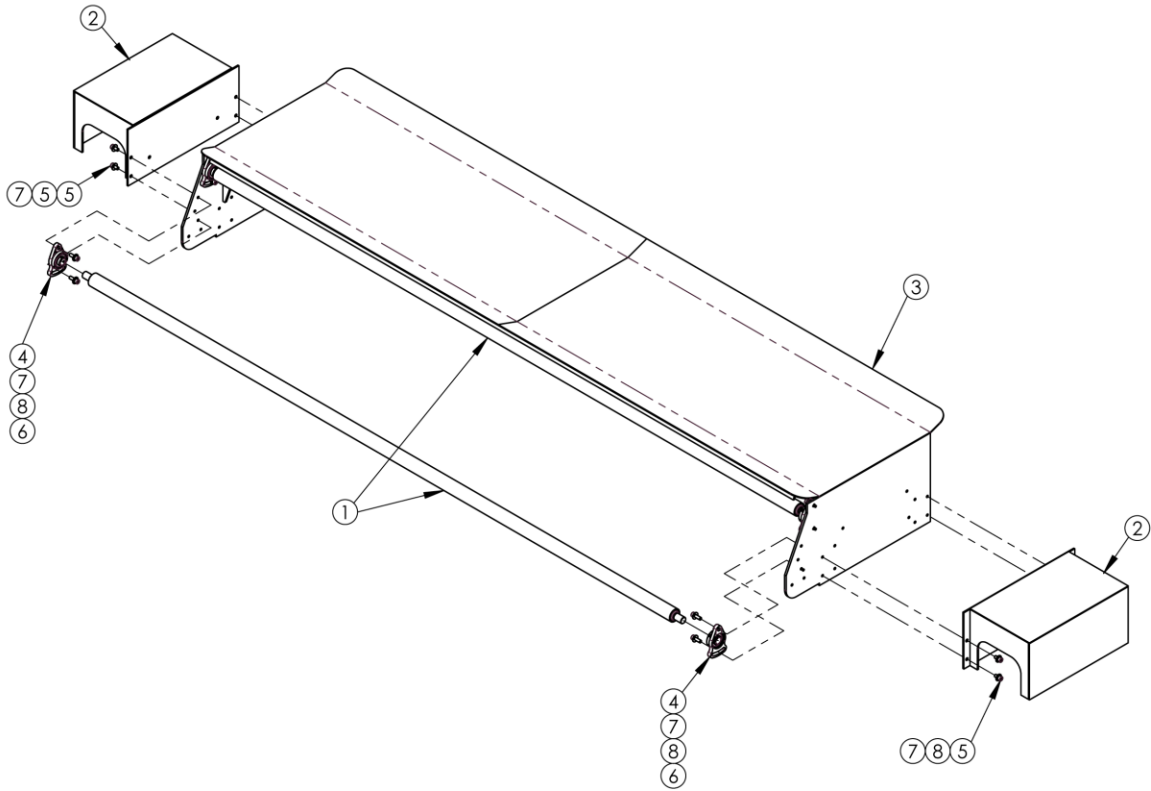

1392193 Operator Platform Assembly

AAC Drawing Number 1392193 Rev 4

NO	QTY	PART #	DESCRIPTION
1	2	5-016	ROLLER, PLATFORM
2	2	5-018	STEP, WELDMENT, PLATFORM
3	1	5-019	PLATFORM, OPERATOR, ASM
4	4	BBUCFA205	BEARING, FLANGE UCFA
5	8	SSSCM10X20	CAP SCREW 10MM X 20MM
6	8	SSSCM10X30	10M X 30MM, SOC CAP
7	16	WWFM10	WASHER, FLAT, M10 I.D.
8	16	WWLM10	M10 LOCK WASHER

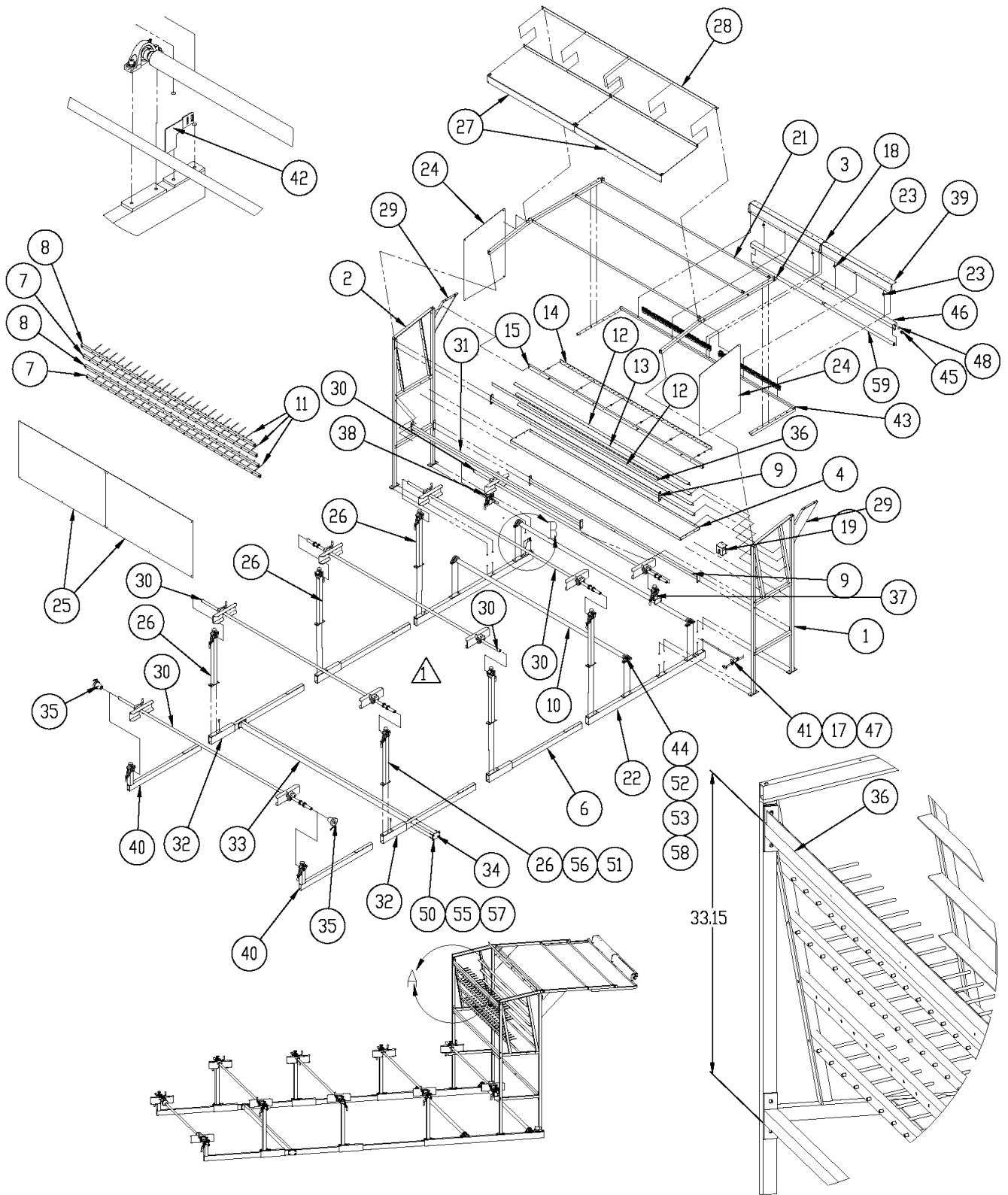

1392195 Thread Stand Frame Assembly

AAC Drawing Number 1392195 Rev 15

NO.	QTY	PART#	DESCRIPTION	NO.	QTY	PART#	DESCRIPTION
1	1	5-001-2-L	STAND,THREAD,FRAME LT	31	1	1392783	SUPPORT, WELDMENT
2	1	5-001-2-R	STAND,THREAD,FRAME RT	32	2	1392825	FRAME, THREAD STAND
3	2	5-001-3B	STAND, THREAD, FRAME	33	1	1392856	CROSS BAR WELDMENT
4	1	5-001-5	STAND, THREAD, FRAME	34	2	1392857	PLATE,WASHER,.359X4@3.75
5	1	5-001-5-3	SHELF,THREAD STAND	35	2	1392906	CONE, ROLL ASSEMBLY
6	2	5-001-8	STAND, THREAD, FRAME	36	1	1392951	ANGLE,COVER ATTACH
7	2	5-001-12A	STAND, THREAD, FRAME	37	1	1392972	TENSION CLAMP ASS, LH, SM
8	2	5-001-13A	STAND, THREAD, FRAME	38	1	1392973	TENSION CLAMP ASS, RH, SM
9	2	5-001-14	SUPPORT, TOP THD STAND	39	2	1393810	MOUNT, LIGHT, FRONT
10	2	5-001A	ROLLER, THREAD STAND	40	2	1393914	BACKING ROLL HOLDER
11	86	5-022	SHAFT, THREAD STAND	41	1	1393937	BRKT,EYE MTG
12	2	6-008	GUIDES, THREAD	42	1	1393938	PLATE,REFLECTOR
13	2	6-009	GUIDES, THREAD	43	1	1393966	MOUNT, LIGHT
14	1	6-014A	EYELET BAR	44	4	BBNAP205-25	BEARING, PILLOWBLOCK
15	1	6-015A	TUBE, EYELET BAR	45	1	FF3216	STRAIN RELIEF, LIQ TIGHT
16	1	1392-002	CABLE,FLUORESCENT	46	2	FFM1414	FIXTURE,LIGHT,4'
17	1	1975-412A	PLATE,NUT,4-40,.95CTC	47	1	FFSM312LVQ	EYE,ELECTRIC,10-30VDC
18	1	1389179	MTG PLATE	48	1	MM9600K36	GROMMET,RUBBER,9/16 ID
19	1	1389398	REMOTE PAUSE,RESTART	49	79	SCT1392L	TENSION ASSY,1392 LOOPER
20	6	1389855	STANDOFF,TENSION,.70"	50	8	SSHCM8X60	SCREW,HEX CAP M8X60
21	3	1392283		51	6	SSSCM10X25	10M X 25MM, SOC CAP
22	2	1392285	STAND, THREAD, FRAME	52	8	SSSCM10X30	10M X 30MM, SOC CAP
23	79	1392308	SPACER, THREAD TENSION	53	8	WWFM10	WASHER, FLAT, M10 I.D.
24	2	1392488	SCREEN,WIND,SIDE	54	4	WWFS3/8	WASHER,FLAT,SAE,3/8
25	2	1392493	SCREEN,WIND,BACK,R	55	8	WWFS5/16	WASHER,FLAT,SAE,5/16
26	6	1392545	MAT. TENSION RACK ASSY	56	4	WWL3/8	WASHER, LOCK, 3/8
27	2	1392553	SCREEN,WIND,TOP	57	8	WWL5/16	WASHER, LOCK, 5/16
28	1	1392602	BRACE	58	8	WWLM10	M10 LOCK WASHER
29	2	1392637	BRACE, FRAME	59	2	ZZZMT-115	BULB,4' FLUORESCENT
30	5	1392763	MATERIAL, ROD ASSEMBLY				

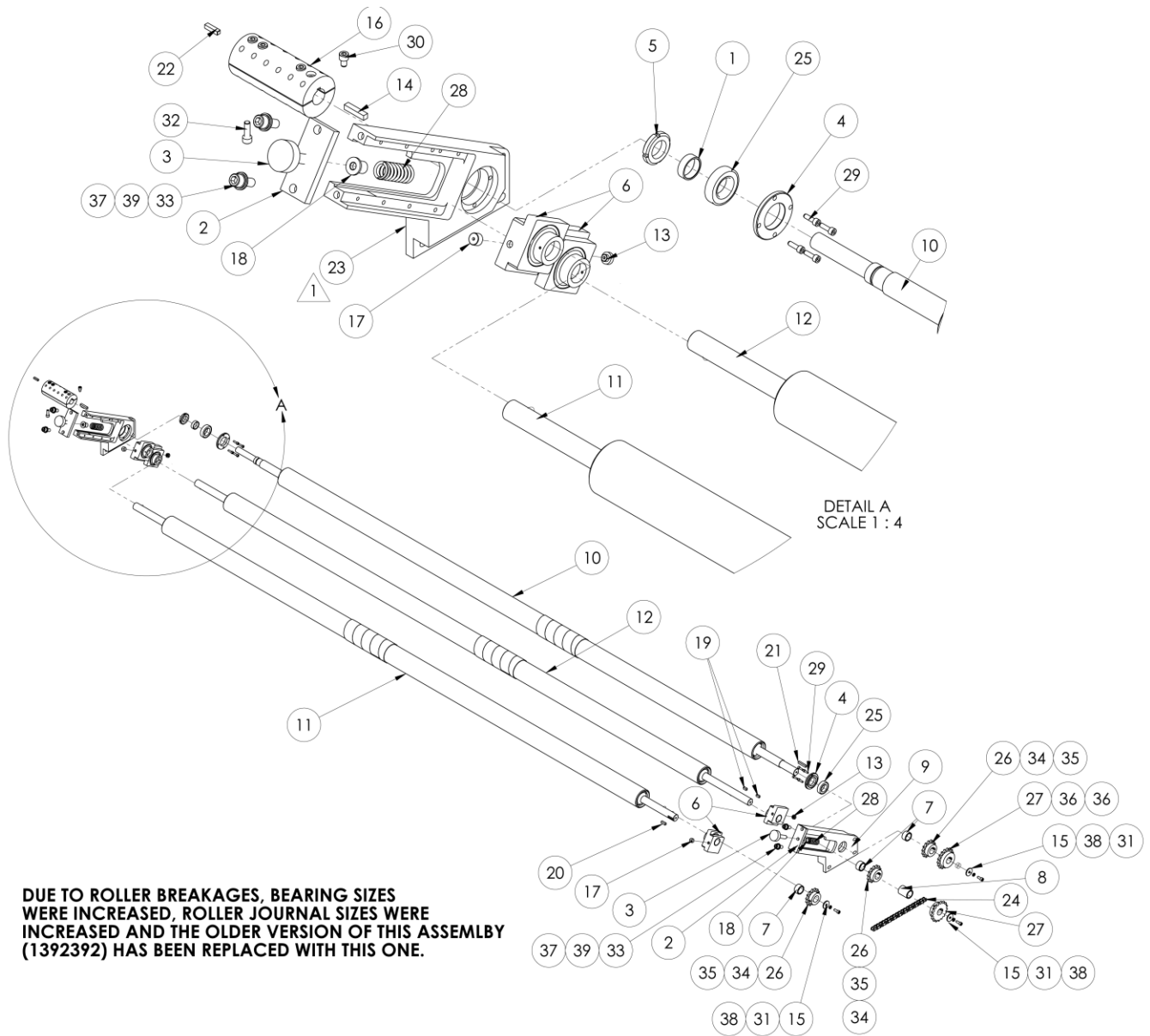

1386740 Rear Feed Roll Dry Assembly

AAC Drawing Number 1386740 Rev 0

NO	QTY	PART #	DESCRIPTION
1	1	3-024A	SPACER,LOWER REAR ROLL
2	2	3-027	BAR,ROLL ADJUSTMENT
3	2	3-031	SCREW,ROLL ADJUSTMENT
4	2	5-020-1	COLLAR, SHAFT,NARROW
5	1	6-039	SPANNER NUT, M30 X 1.5
6	4	1386729	REAR PULL ROLL BRG ASM
7	3	1386730	SLEEVE,SPACER,30MM ID
8	1	1386731	SLEEVE,SPACER,30MM ID
9	1	1386732	REAR FEED ROLL MOUNT, LH
10	1	1386733	LOWER ROLLER, DRIVEN
11	1	1386737	TOP REAR FEED ROLLER
12	1	1386739	MIDDLE REAR FEED ROLL
13	2	1386741	REAR FEED ROLL STOP
14	1	1388763	KEY, 8 MM X 38MM
15	3	1388853	PLATE,PULL ROLLER END CAP
16	1	1389236	COUPLING,Y-AXIS DRIVE
17	2	1392127	LOCATOR,SPRING
18	2	1392128	ADAPTER,COMPRESSIONSPRING
19	2	1392671	KEY,7MMX8MMX.71 IN
20	1	1392672	KEY,7MMX8MMX.96 IN
21	1	1392673	KEY,7MMX8MMX1.75 IN
22	1	1392687	KEY, 6mm
23	1	1392941	WELDMENT,RH REAR BRG MT
24	1	1393463	CHAIN, INSIDE, 36.5 L
25	2	BB60062RS	BEARING,BALL,30MM B,2 SL
26	3	MMH5014X30	SPROCKET,14T,5/8P, 30MM B
27	2	MMH5017X30	SPROCKET,17T,5/8P,30MM B
28	2	RRLHC148J03	SPRING,1.1OD,.148WIRE,2.5
29	8	SSSCM6X20	M6 X 20, SOC CAP
30	4	SSSCM8X12	SCREW,SOC CAP,M8X12
31	3	SSSCM8X20	M8X20 SOC CAP
32	12	SSSCM8X25	M8-1.25 X 25 SOC CAP
33	4	SSSCM12X30	SCREW, SOC CAP, M12 X 30
34	3	SSSSM8X10	M8 X 10, SOC SET SCRW
35	3	SSSSM8X12	M8X12 SOC SET SCRW
36	4	SSSSM8X16	M8X16 SOC SET SCRW
37	4	WWFM12	WASHER, FLAT, M12 I.D.
38	3	WWLM8	M8 LOCK WASHER
39	4	WWLM12	M12 LOCK WASHER

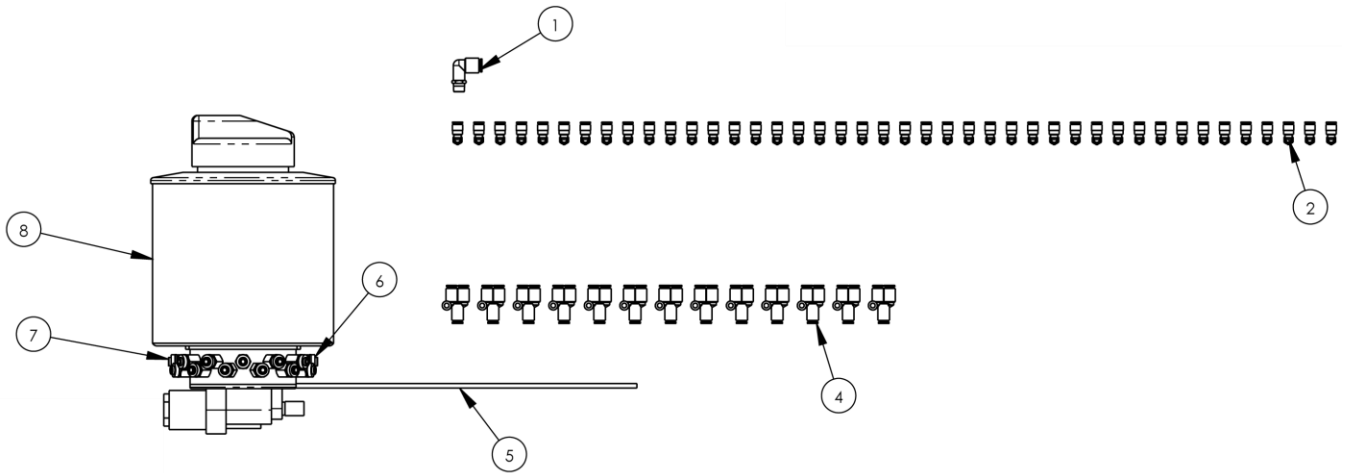

1392415 Lubrication Assembly

AAC Drawing Number 1392415 Rev 7

NO.	QTY	PART #	DESCRIPTION
1	1	AAQME-4-8U	QUICK MALE ELBOW,1/4X1/8
2	45	AAQME-M4-M6	QUICK ELBOW CONNECTOR
3	9	AAQUT-5-5	UNION TEE 5/32
4	13	AAQUY-5-5	QUICK UNION Y, 5/32
5	250 FT	AATP4X2MW	TUBING,NYLON,5/32OD
6	2	MM78034PL	INJECTOR,GREEN.015CC
7	22	MM78035PL	INJECTOR,YELLOW.025CC
8	1	MMXGS4024	PUMP,GREASE,24 STATION

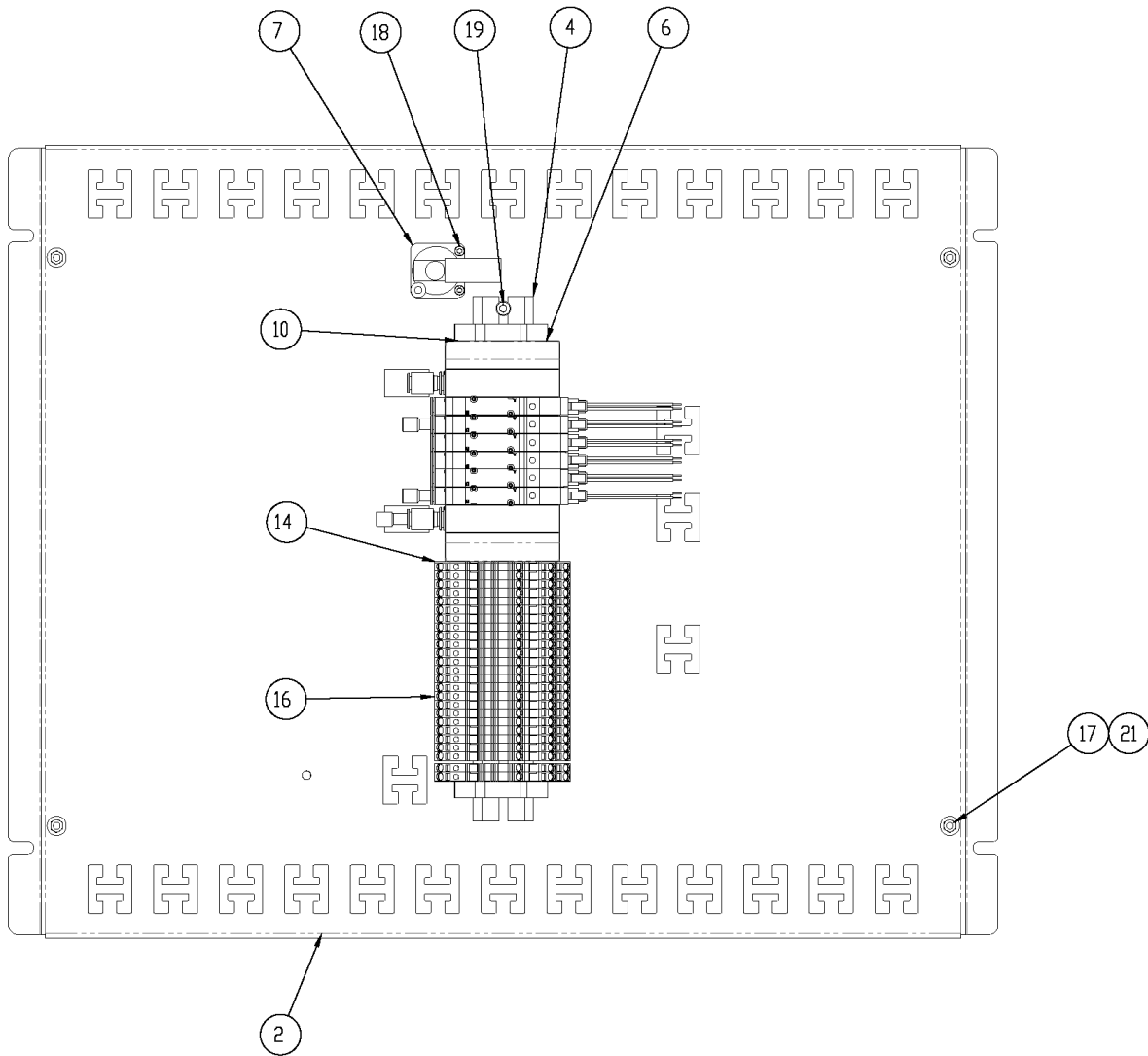

1392505 Remote Electrical Panel

AAC Drawing Number 1392505 Rev 3

NO.	QTY	PART#	DESCRIPTION	NO.	QTY	PART#	DESCRIPTION
1	*AR	1392-WD2	DIAGRAM,WIRING,PANEL	12	*AR	FF209-503	TERMBLK,WAGO (11-20)
2	1	1392506	PANEL,BACK,ELECTRICAL	13	*AR	FF209-504	TERMBLK,WAGO (21-30)
3	1	1392507	COVER,PANEL	14	2	FF280-319	TERMBLK,WAGO,SENSOR,DIN
4	1	1392508	DIN RAIL,35MM,12" LG	15	*45	FF280-402	JUMPERS
5	1	1392689	CABLE ASSY,F,QUILTER I/O	16	25	FF280-560	TERMBLK,WAGO,SENSOR,DIN
6	1	AAE1392	6 SOLENOID ASSEMBLY	17	4	NNHM4X0.7	M4 X 0.7 HEX NUT
7	1	AAVF51FM1B	AIR/ELEC PRESSURE SW	18	2	SSSCM3X10	M3-0.5 X 10 SOC CAP
8	*AR	EE6X753	CABLE TIE	19	2	SSSCM5X10	M5-0.8 X 10 SOC CAP
9	*2	EE8442	CABLE,2 COND,22 AWG	20	*2	TTAA5267	TERMINAL,FE,FUL INS,18-22
10	2	EECLIPFIX	ANCHOR,DIN RAIL	21	4	WWF8	WASHER, FLAT #8
11	*AR	FF209-502	TERMBLK,WAGO (1-10)				

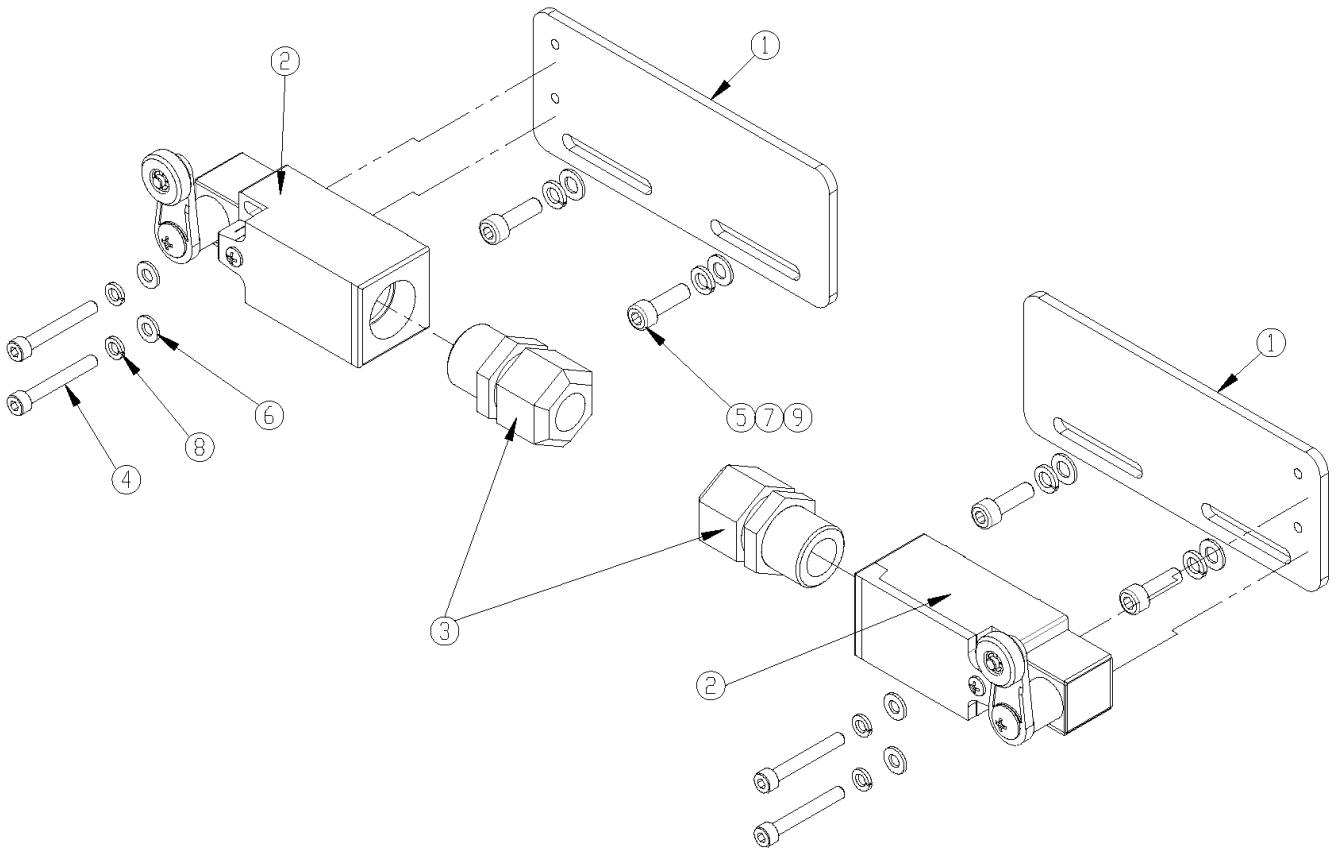

1392744 Limit Switch Assembly

AAC Drawing Number 1392744 Rev 2

NO.	QTY	PART#	DESCRIPTION
1	2	1392497	BRACKET,LIMIT SWITCH
2	2	FFGLA01A1B	SWITCH, LIMIT, ROLLER ARM
3	2	FFM4518	STRAIN RELIEF,LIQ TIGHT
4	4	SSSCM4X30	SCREW,SOC CAP,M4-0.7X30
5	4	SSSCM5X16	SCREW,SOC CAP,M5-0.8 X 16
6	4	WWFM4.3	WASHER, FLAT, M4
7	4	WWFM5	WASHER, FLAT, M5 I.D.
8	4	WWL8	WASHER,LOCK,#8
9	4	WWLM5	M5 LOCK WASHER

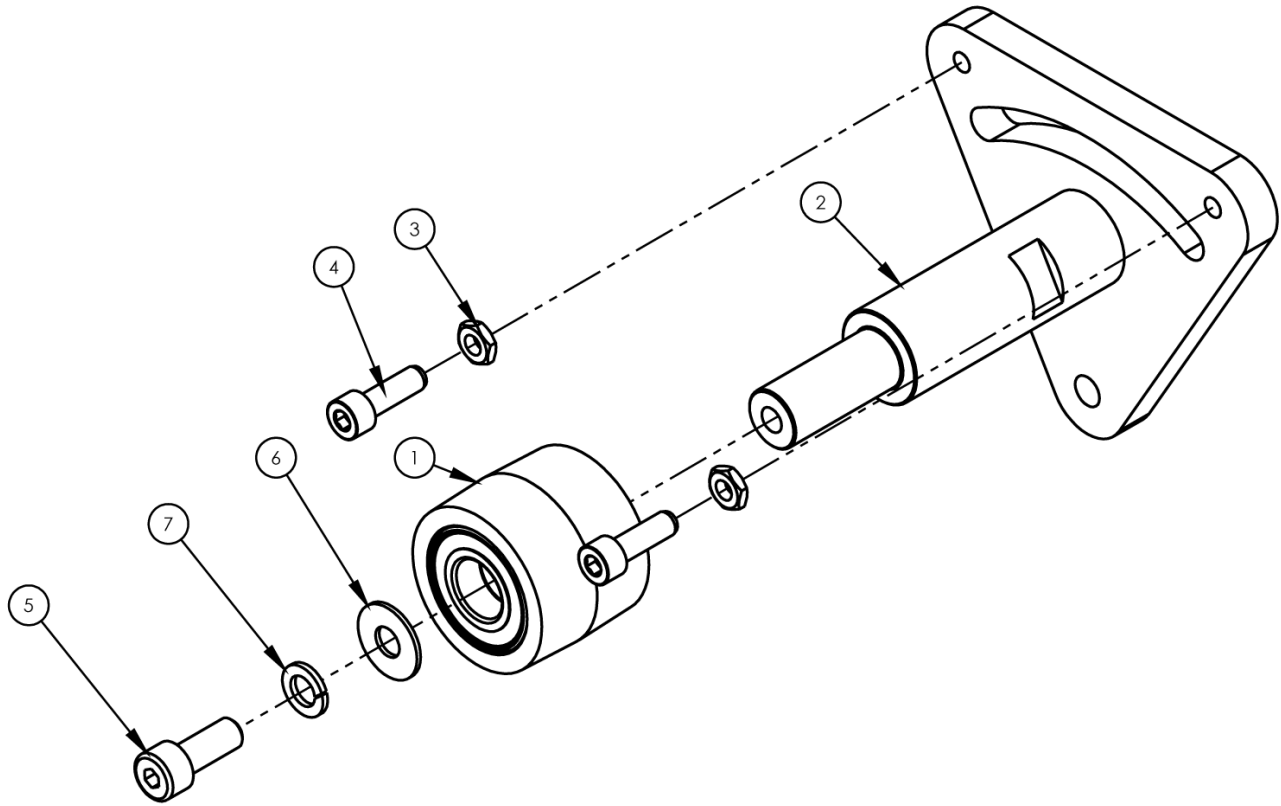

1392898 Y Axis Drive Idler Assembly

AAC Drawing Number 1392898 Rev 4

NO.	QTY	PART #	DESCRIPTION
1	1	1392501	IDLER, BEARING ASSEMBLY
2	1	1393968	DRIVE, IDLER, WELDMENT
3	2	NNJM8	NUT, JAM, M8, ZINC PLATED
4	2	SSSCM8X25	SCREW, SOC CAP, M8X25
5	1	SSSCM10X25	10M X 25MM, SOC CAP
6	1	WWF3/8	WASHER, FLAT, 3/8 OR 10MM
7	1	WWLM10	M10 LOCK WASHER

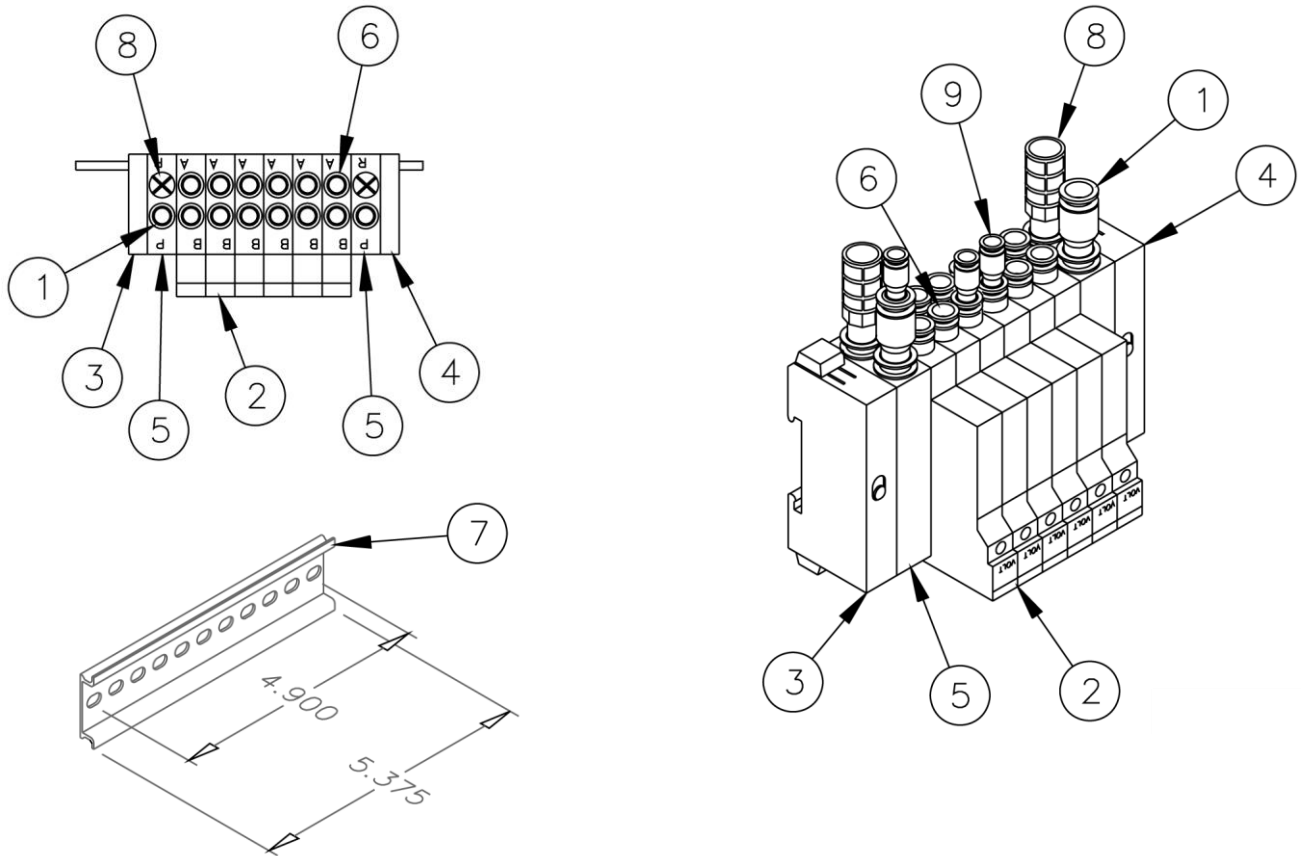

AAE1392 6 Station Solenoid Assembly

AAC Drawing Number 192121B Rev 2

NO.	QTY	PART #	DESCRIPTION
1	2	KQR07-09	Reducing Fitting
2	6	SY3140-5LZ	Solenoid
3	1	SX3000-53-1A	Left Cap End
4	1	SX3000-52-1A	Right Cap End
5	2	SX3000-51-15A	Block
6	6	SX3000-50-1A-N7	Block Assy.
7	5.38	VZ1000-11-1-9	Din Rail
8	2	AN203-KM8	Port Silencer
9	3	KQ2P-07	Plug

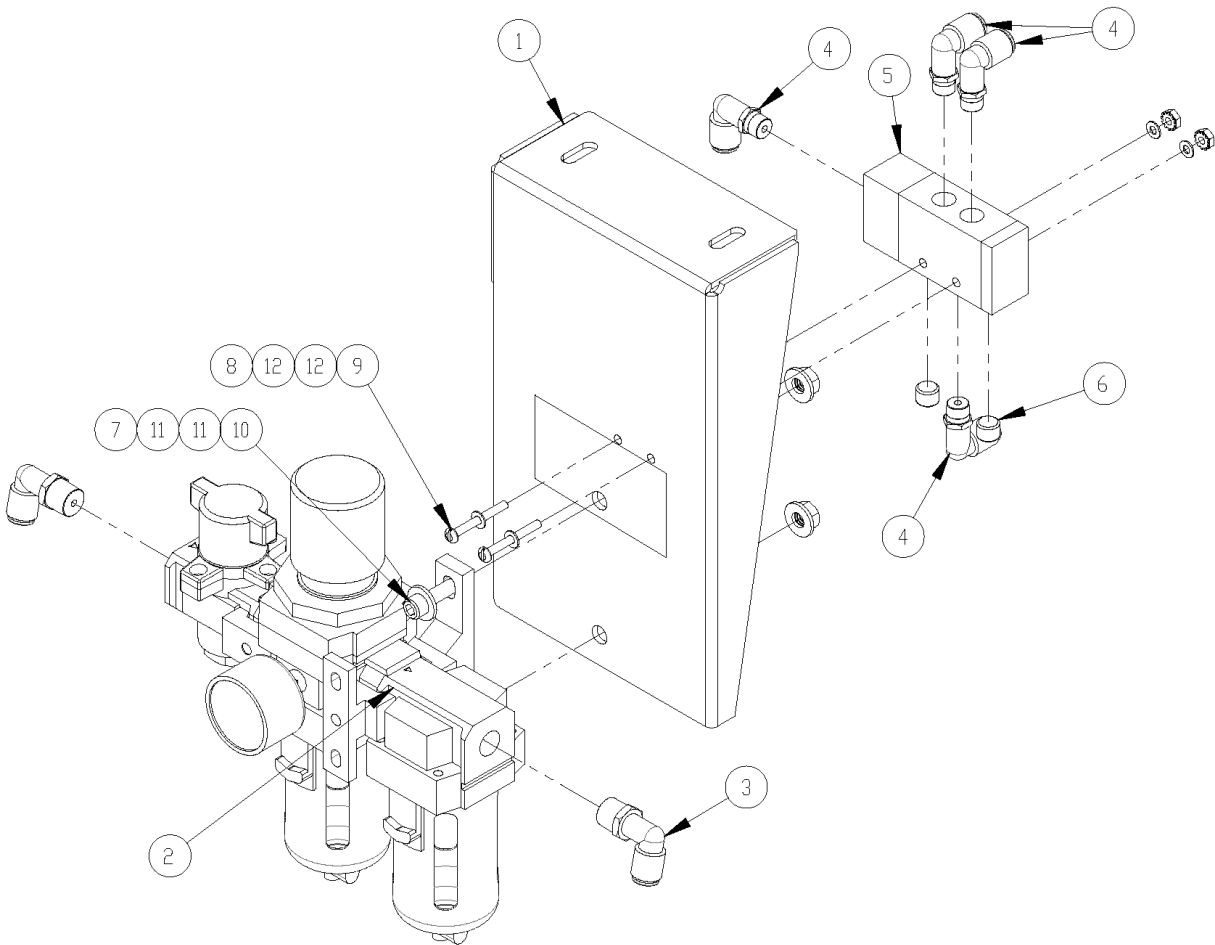

1393854 Filter Regulator Lockout Assembly

AAC Drawing Number 1393854 Rev 1

NO.	QTY	PART#	DESCRIPTION
1	1	32003033	BRKT,REGULATOR,DUAL
2	1	AA198-5110	FILTER/REGULATOR/LOCKOUT
3	2	AAQME-4-4	ELBOW, MALE,1/4X1/4NPT
4	4	AAQME-4-8	ELBOW,QUICK MALE,1/4X1/8
5	1	AAV125B	PILOT VALVE
6	2	MM4554K11	PLUG, 1/8" PIPE
7	2	NNK1/4-20	NUT,HEX,KEP,1/4-20,W/LOCK
8	2	NNK6-32	KEP NUT, 6-32
9	2	SSPS80080	#6-32 X 3/8 LG PAN HD
10	2	SSSC01048	1/4-20 X 3/4" SOC CAP SC
11	4	WWFS1/4	WASHER,FLAT,SAE,1/4
12	4	WWFS6	WASHER, FLAT, #6

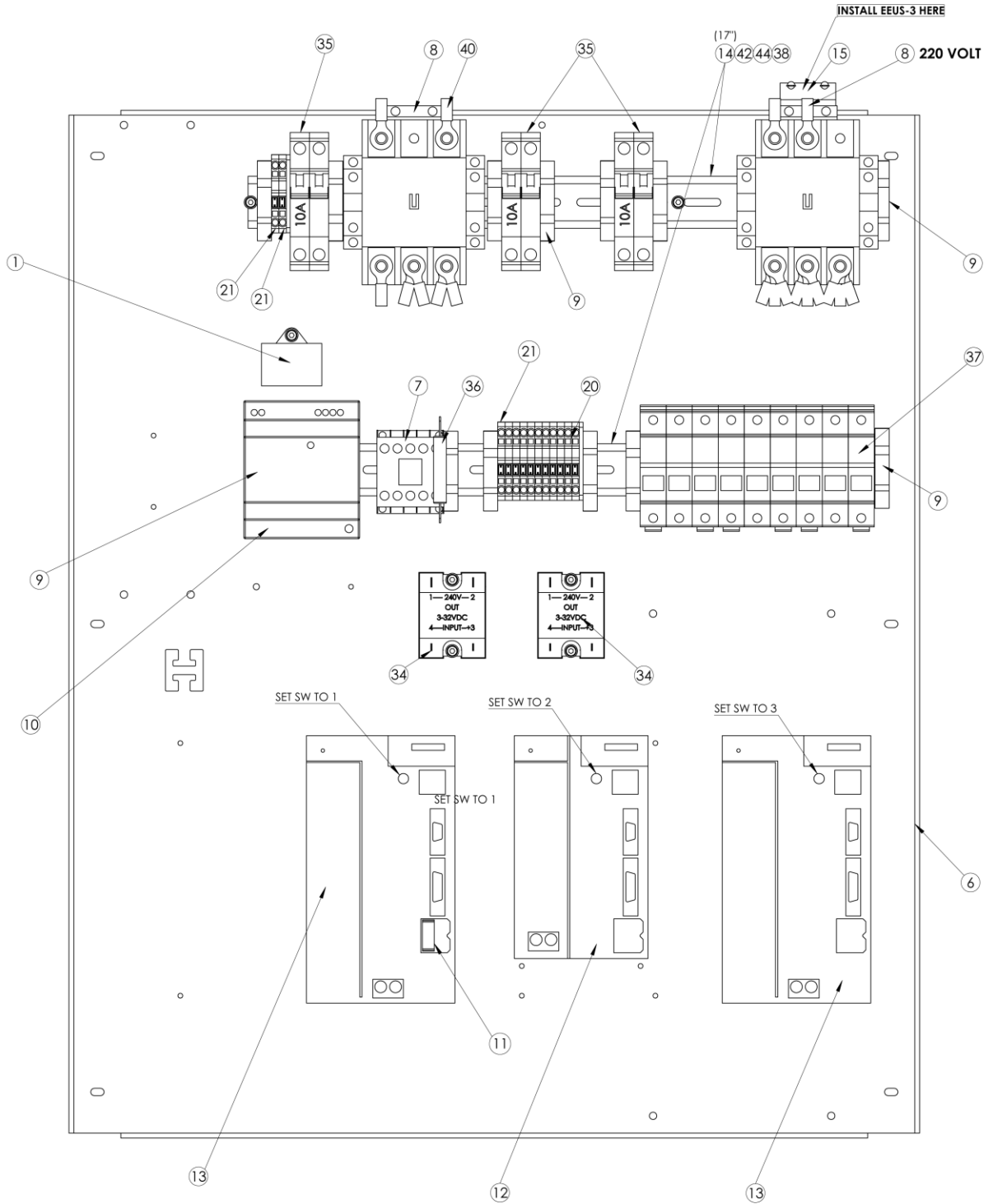

1392367 Backplane Assembly, Back Side

AAC Drawing Number 1392367 Rev 5

NO	QTY	PART	DESCRIPTION
1	1*	1392657	SURGE SUPPRESSOR ASSY
2	1*	1392658	CABLE ASSY,TRANS PRI
3	1*	1392659	CABLE ASSY,E-STOP RCPT
4	1*	1392661	CABLE ASSY,CLOSER RCPT
5	1*	1392662	CABLE ASSY,SPIRAL RCPT
6	1	1392685	PANEL, FRONT BACKPLANE
7	1	EECA491024	CONTACTOR, MINI, 240V
8	2	EECGC85A220	CONTACTOR,65A,220VAC
9	16	EECLIPFIX	ANCHOR,DIN RAIL
10	1	EEDR3024	POWER SUP,SWITCHER,24V
11	1	EEJPMCW6022	TERMINATION,BLOCK
12	1	EESGDS15A12A	AMPLIFIER, SERVO DRIVER
13	2	EESGDS30A12A	AMPLIFIER, SERVO DRIVER
14	34"	EETS35X7.5A	DIN RAIL-AMERICAN
15	1	EEUS-3	RC+SURGE SUPPRESSOR
16	AR	FF209-502	TERMBLK,WAGO,TP,LG,MARK,1-10
17	AR	FF209-503	TERMBLK,WAGO,TP,LG,MARK,11-20
18	2	FF280-308	TERMBLK ENDPLATE,WAGO,280
19	8*	FF280-402	JUMPER,WAGO,280,SINGLE
20	10	FF280-901	TERMBLK,WAGO,TOP,SNGL,GRY
21	3	FF280-907	TERMBLK,WAGO,TOP,SNGL,GRN
22	10 FT*	FF3077-1	WIRE,STR,#16,PVC,WHT
23	10 FT*	FF3077-2	WIRE,STR,#16,PVC,BLK
24	10 FT*	FF3077-3	WIRE,STR,#16,PVC,RED
25	10 FT*	FF8908-2	WIRE,STR,#8,PVC,RED
26	10 FT*	FF8908-10	WIRE,STR,#8,PVC,BLK
27	10 FT*	FF8908-13	WIRE,STR,#8,PVC,BLU
28	4 FT*	FF9740	CABLE,2 COND,18 AWG,300V
29	10 FT*	FF9912-2	WIRE,STR,#12,PVC,RED
31	10 FT*	FF9912-6	WIRE,STR,#12,PVC,BLUE
31	10 FT*	FF9912-10	WIRE,STR,#12,PVC,BLACK
32	10 FT*	FF31572787	WIRE,STR,#10,PVC,GRN/YEL
33	9 FT*	FFATMR20	FUSE,CC,20A,FAST,CURLIM
34	2	FFD2425F	RELAY,SSR,24VAC,25A
35	3	FFQL213DMKM10	CIRCUIT BREAKER,10A,2P
36	1	FFR10K10W	RESISTOR,10K,10W,5%
37	3	MM1492FB3C30	FUSE HOLDERS,3 POLE
38	15	SSSCM4X16	SCREW, SOCKET CAP
39	11	SSSCM5X10	SCREW,SOC CAP,M5-0.8 X 10
40	18	TT190730242	TERMINAL,RING,5/16"STD
41	4*	TBB5263	TERMINAL,.25 FULLY INSUL
42	15	WWFM4.3	WASHER, FLAT, M4
43	11	WWFM5	WASHER, FLAT, M5 I.D.
44	15	WWL8	WASHER,LOCK,#8
45	11	WWL10	WASHER,LOCK,#10

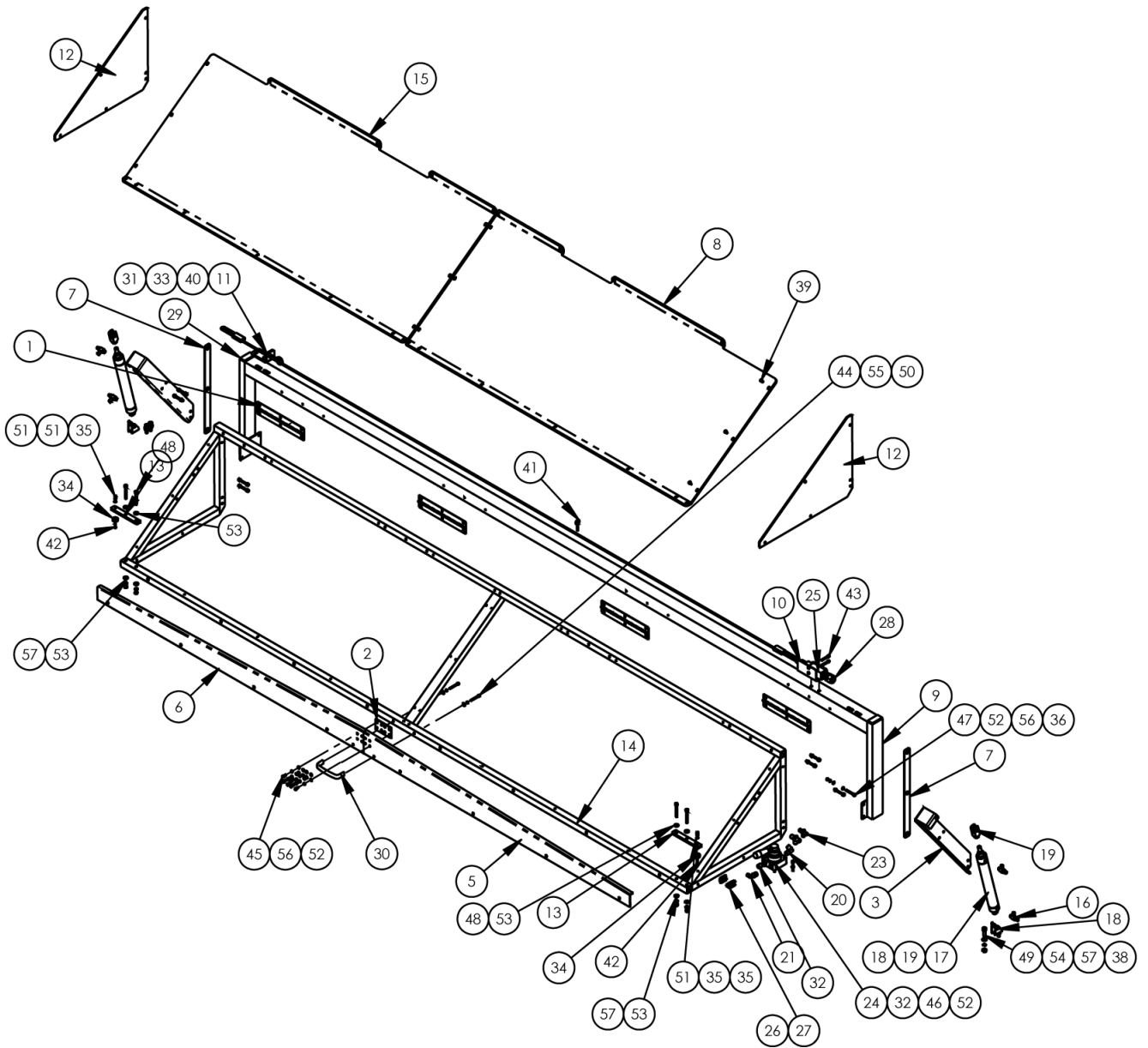

1388560 Front Guard Assembly

AAC Drawing Number 1388560 Rev 0

NO.	QTY	PART #	DESCRIPTION	NO.	QTY	PART #	DESCRIPTION
1	4	1337-4217	HINGE,PIANO,S/S, 2W, .06THK.	30	1	MM1897A24	HANDLE,DOOR,PULL,OVAL,5/8
2	1	1388106	PLATE,FRONT COVER	31	2	MM3471T23	CLAMP,ROPE,WIRE,3/16", STEEL
3	1	1388561	BRACKET, RIGHT GUARD LIFT	32	1	MM4554K12	PLUG, 1/4" PIPE
4	1	1388566	BRACKET, LEFT GUARD LIFT	33	*10	MM8923T81	ROPE,WIRE,SS,3/16",RED
5	1	1389453	BRACKET, FRONT COVER,RH	34	2	MM9405K14	BUMPER,RECESSED,ELASTOMER
6	1	1389454	BRACKET, FRONT COVER,LH	35	4	NNHM4X0.7	NUT,HEX,M4-0.7
7	2	1389792	PLATE,WASHER	36	8	NNHM5X0.8	NUT,HEX,M5-0.8
8	1	1392356	COVER,FRONT,LEXAN,R	37	4	NNHM6X1.0	M6 X 1.0 HEX NUT
9	1	1392502	WELDMENT,FRONT GUARD SUPP	38	4	NNHM8X1.25	M8 X 1.25 HEX NUT
10	1	1392530	BRACKET,SAFETY SWITCH	39	*86	SSBCM5X12S	SCREW,BUTTON CAP,S/S
11	1	1392532	BRKT,EYEBOLT MTG	40	1	SSBE10160	EYEBOLT,5/6-18X2.5
12	2	1392608	COVER,FRONT SIDE,LEXAN	41	1	SSBE95080	EYEBOLT,10-24X1-1/4
13	2	1392727	STOP, FRONT GUARD	42	2	SSPSM4X16	M4-0.70X16 PAN HS SLOTTED
14	1	1392943	FRAME,FRONT COVER	43	2	SSSC98080	10-32 X 1-1/4 SOC CAP
15	1	1392953	COVER,FRONT,LEXAN,L	44	2	SSSC98096	10-32 X 1-1/2 SOC CAP
16	4	AA198RA508	FLOW CONTROL,5/32 X 1/8"	45	8	SSSCM5X10	SCREW,SOC CAP,M5-0.8 X 10
17	2	AAC127DP	CYLINDER,AIR,DA, 7" STK	46	4	SSSCM5X35	SCREW,SOCKET CAP,M5X5
18	2	AAFBP-25C	BRKT,PIVOT,1/4 BORE	47	8	SSSCM5X40	SCREW,SOCKET CAP,M5X40
19	2	AAFCT-15	CLEVIS,AIR CYL,7/16-20	48	4	SSSCM6X50	M6X50 SOC CAP SCREW
20	1	AAQME-4-4	ELBOW, MALE,1/4X1/4NPT	49	4	SSSCM8X25	SCREW,SOC CAP,M8X25
21	1	AAQME-5-4	ELBOW, MALE 5/32X1/4NPT	50	2	WWF10	WASHER, FLAT, #10, COM
22	1	AAQUT-4-4	QUICK UNION T 1/4X1/4	51	2	WWFM4.3	WASHER, FLAT, M4
23	1	AAQUT-5-5	QUICK UNION T,5/32X5/32	52	28	WWFM5	WASHER, FLAT, M5 I.D.
24	1	AAVH202N02	PNEUMATIC, VALVE, MANUAL	53	8	WWFM6.1	WASHER, FLAT, M6, SAE
25	1	EEPS21RNN7T	SWITCH,SAFETY,CABLE PULL	54	4	WWFM8	WASHER, FLAT, M8 I.D.
26	1	FF57105000	REED SWITCH MAGNET,FLANGE	55	2	WWL10	WASHER,LOCK,#10,S/S
27	1	FF59105010	REED SWITCH, FLANGE,N.O	56	16	WWLM5	M5 LOCK WASHER
28	1	FFM4518	STRAIN RELIEF,LIQ TIGHT	57	8	WWLM6	M6 LOCK WASHER
29	2	MM132-1496	PLUG 1 X 2				

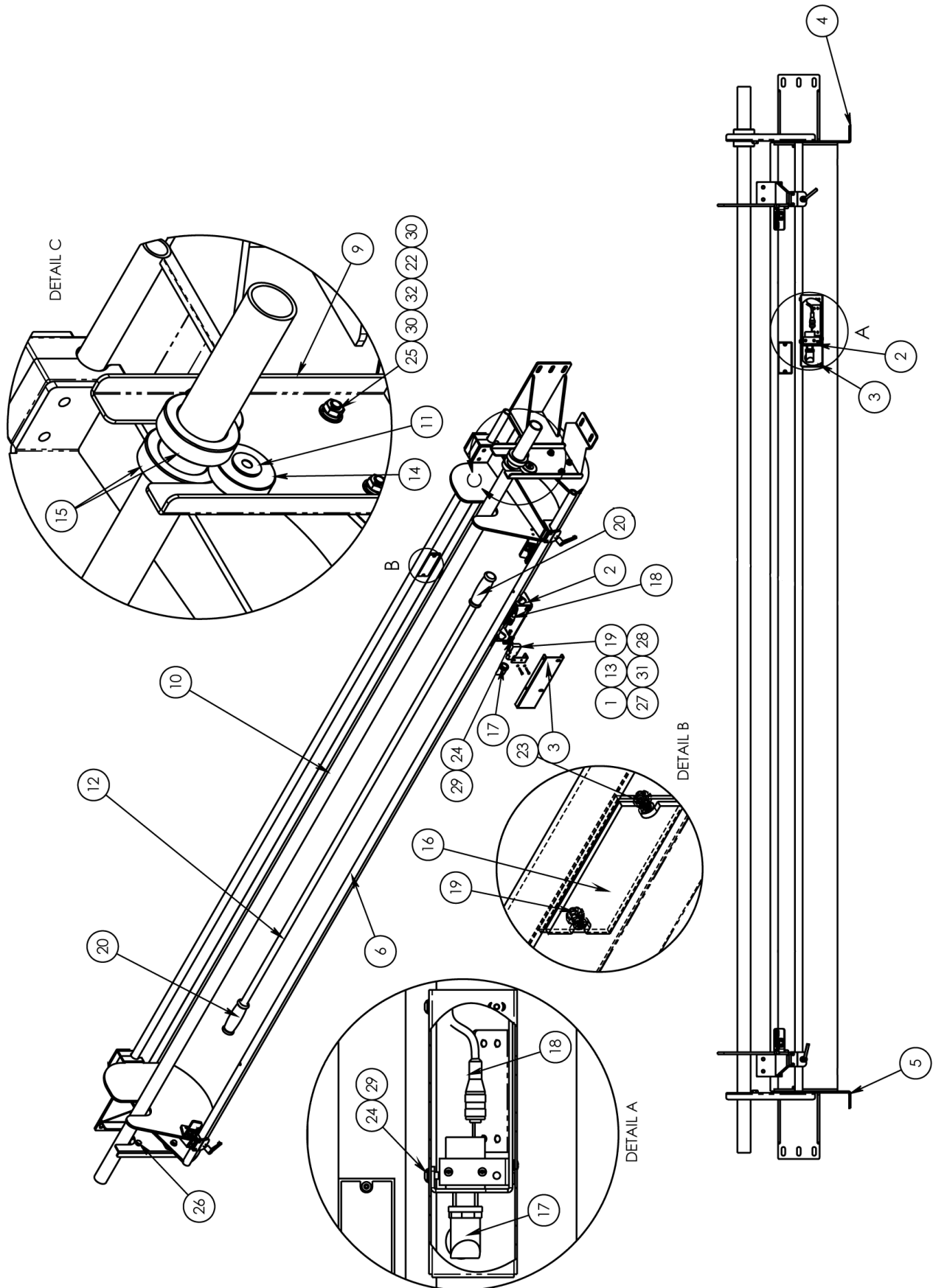

1392087 Front Tray Assembly

AAC Drawing Number 1392087 Rev 7

NO.	QTY	PART #	DESCRIPTION
1	1	1387004	BRACKET, SENSOR MOUNT
2	1	1387005	BRACKET, TICKING SENSOR
3	1	1389424	COVER, SENSOR BRACKET
4	1	1389427	BRKT,RH
5	1	1389432	BRKT,LH
6	1	1392040	MATERIAL TRAY ASSEMBLY
7	1	1392084	MATERIAL END, LEFT
8	1	1392085	MATERIAL END, RIGHT
9	2	1392452	BRACKET, ROLL HOLDER
10	1	1392457	TUBE, 1.5 "OD X 120" L
11	4	1392476	BUSHING, BEARING MOUNT
12	1	1393945	ROD, TICKING
13	1	1975-412A	PLATE,NUT,4-40,.95CTC
14	4	BB1L017	BEARING,BALL,.787B
15	2	CCCL24F	CLAMP COLLAR, 1.5" BORE
16	1	EERL105	REFLECTOR, RECTANGULAR
17	1	EEST03	ADAPTER, RIGHT ANGLE
18	1	FFRK44T-4	CABLE,EYE,12',NO END
19	1	FFSM312LVQ	EYE,ELECTRIC,10-30VDC
20	2	MMGP-105	GRIP HANDLE-FOAM 3/4 ID
21	2	NNE6-32	NUT,ELASTIC LOCK,6-32
22	6	NNH5/16-18	5/16-18 HEX NUT
23	2	SSBC80024	6-32 X 3/16 BUT HEAD
24	8	SSBCM5X8	SCREW,BUTTON CAP
25	6	SSHC10064	5/16-18 X 1 HHCS
26	4	SSHC25048	3/8-16X3/4,HEX CAP
27	2	SSPP90024	8-32X3/8 PAN PHLPS
28	2	SSPS70048	4-40 X 3/4 PAN HD SLOTTED
29	4	WWFM5	WASHER, FLAT, M5 I.D.
30	12	WWFS5/16	WASHER,FLAT,SAE,5/16
31	2	WWL4	WASHER,LOCK,#4
32	6	WWL5/16	WASHER, LOCK, 5/16
33	2	WWL8	WASHER,LOCK,#8

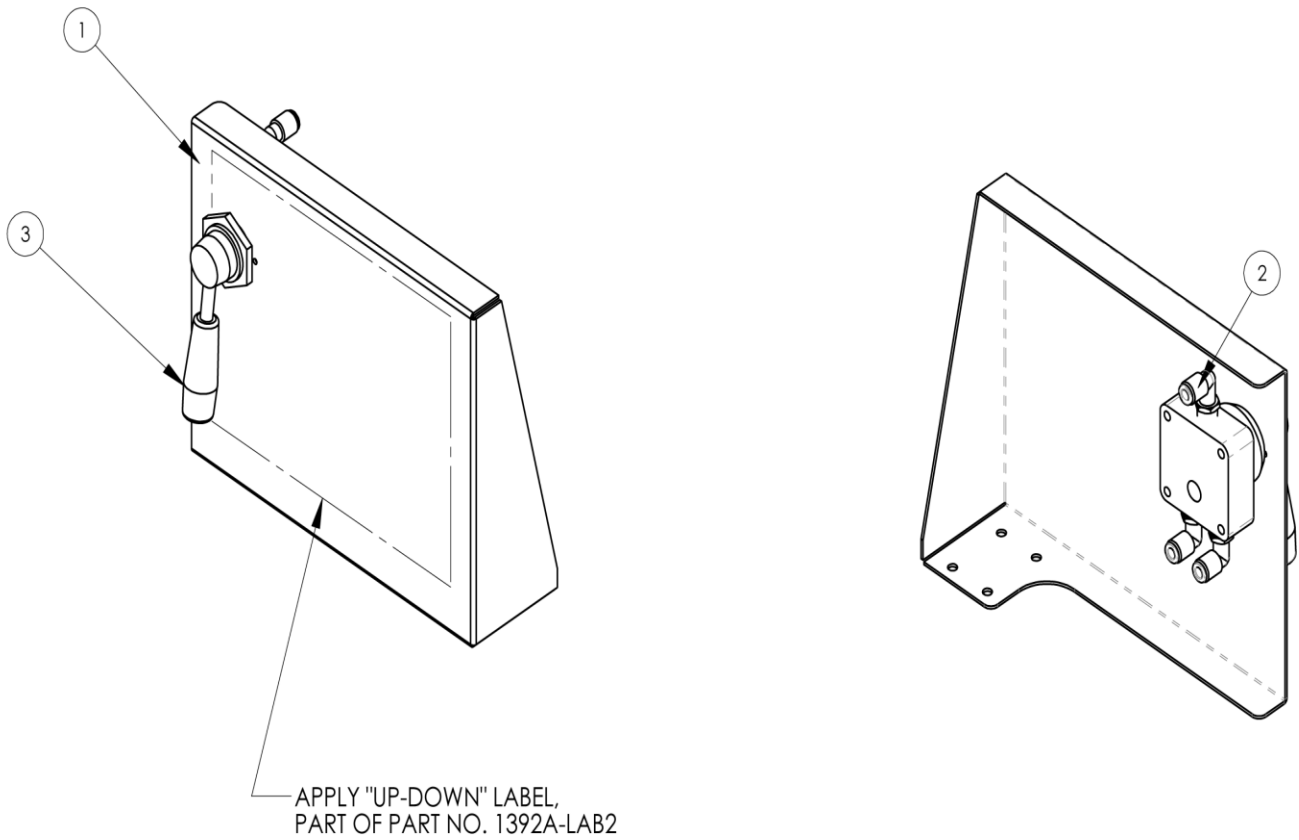

1393940 Regulator Valve Assembly

AAC Drawing Number 1393940 Rev 1

NO.	QTY	PART #	DESCRIPTION
1	1	1393939	PLATE, VALVE/REG MTG
2	3	AAQME-4-4	ELBOW, MALE, 1/4X1/4NPT
3	1	AAVH202-N02	VALVE, HAND, 2 POSITION

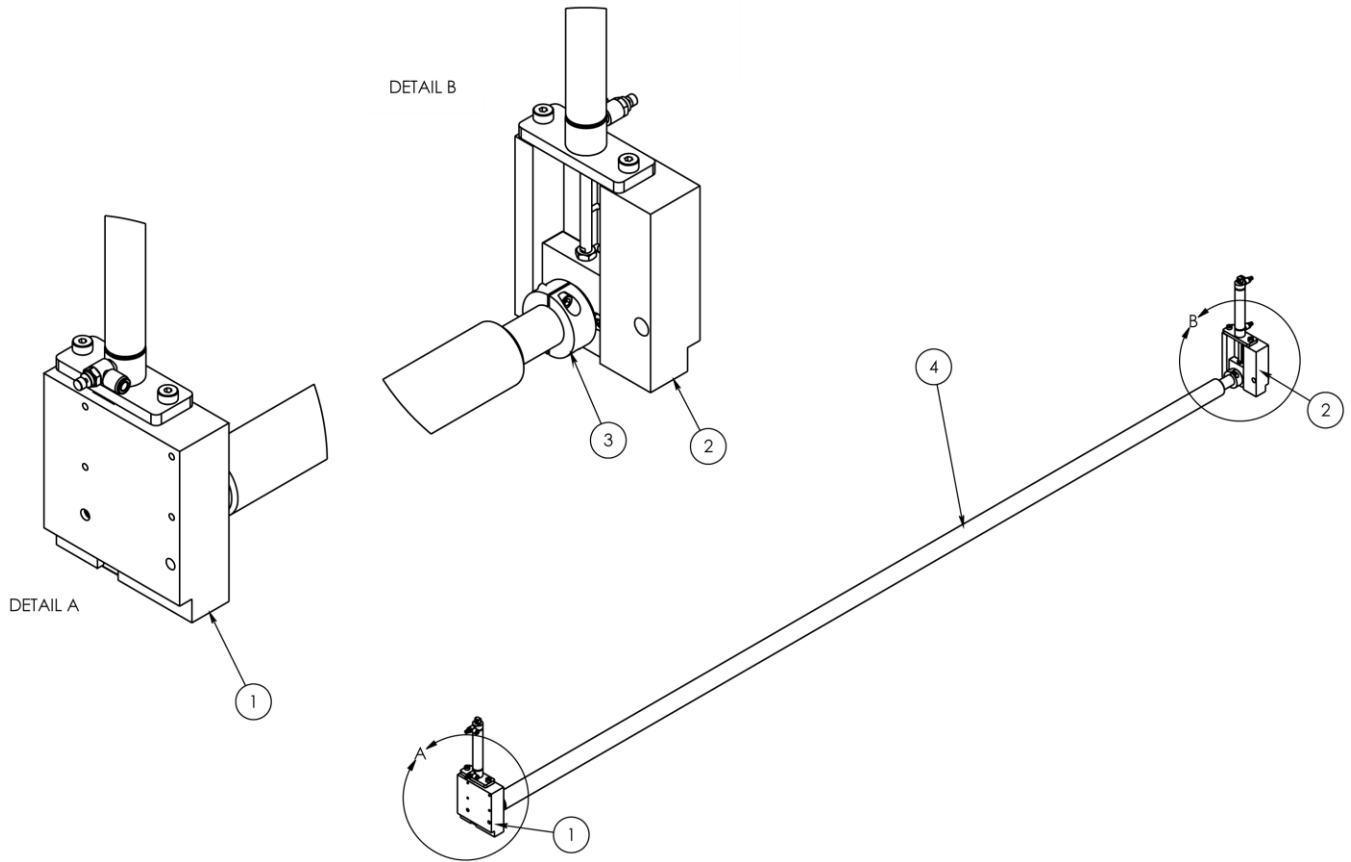

1392306 Roller Lift Assembly

AAC Drawing Number 1392306 Rev 3

NO.	QTY	PART #	DESCRIPTION
1	1	1389085	ROLLER LIFT ASSEMBLY, LT
2	1	1392095	ROLLER LIFT ASSEMBLY
3	2	1393895	COLLAR, END PLAY
4	1	3-005	ROLLER

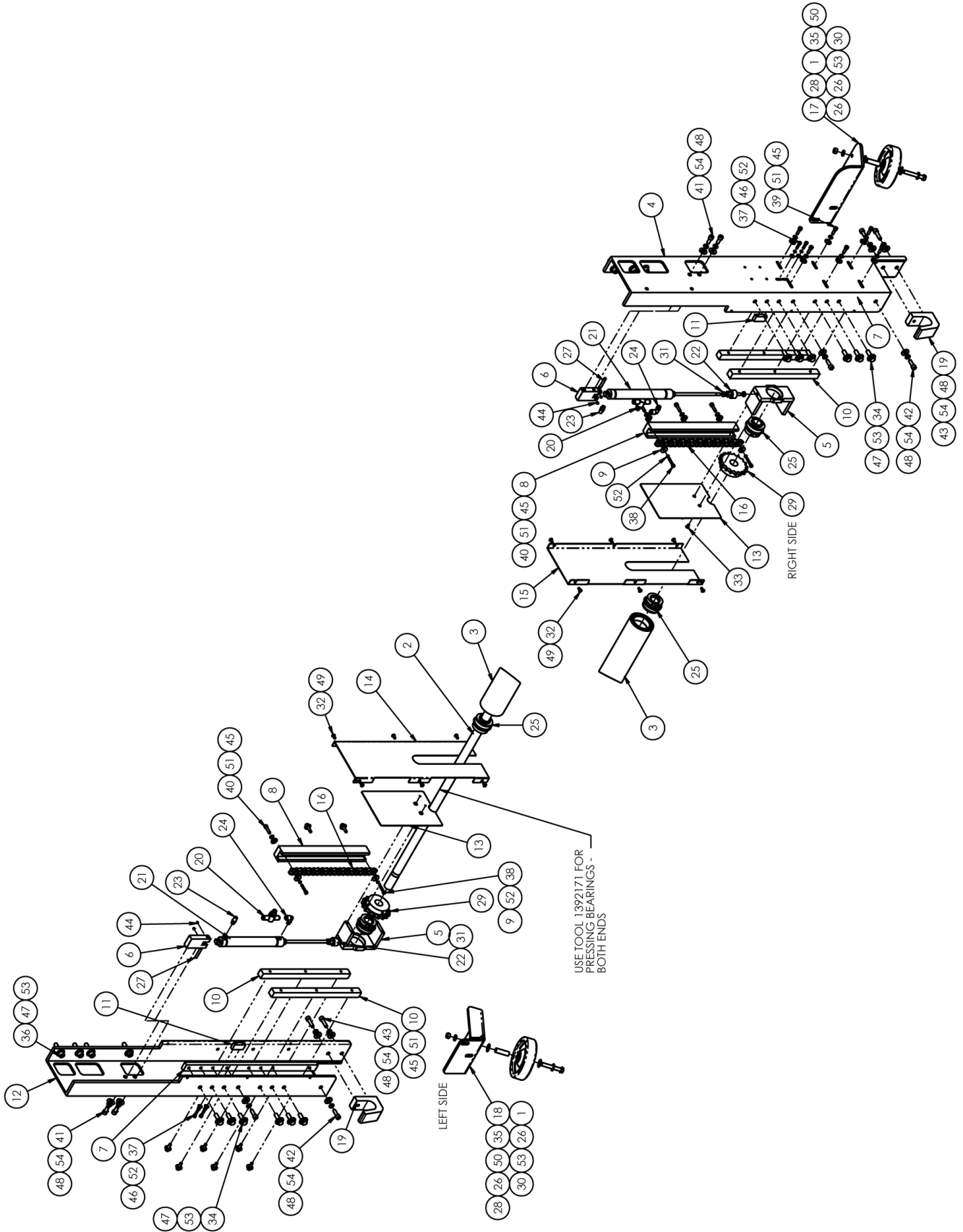

1392448 Tension Roller Assembly

AAC Drawing Number 1392448 Rev 6

NO.	QTY	PART #	DESCRIPTION	NO.	QTY	PART #	DESCRIPTION
1	2	1345119	TUBE,SPACER,ROLLER	28	2	MM2315T528	WHEEL, PHENOLIC
2	1	1392877	SHAFT, TENSION ROLLER	29	2	MM50B17M	STEEL SPROCKET,17T,5/8P
3	1	1392878	ROLLER, TICK TENSION	30	2	NNH3/8-16	NUT,HEX,3/8-16
4	1	1392881	SUPPORT, TENSION ROLLER	31	4	NNJ5/16-24	NUT,JAM,5/16-24
5	2	1392882	HOUSING, BEARING	32	12	SSBCM5X12	SCREW,BUTTON CAP
6	2	1392895	MOUNT, CYLINDER	33	2	SSFCM5X10	M5-0.8X10 FLAT ALLEN
7	2	1392896	NUT PLATE, TENSION ROLLER	34	12	SSHC25080	3/8-16 X 1-1/4 HEX CAP
8	2	1392899	HOLDER, ROLLER CHAIN	35	2	SSHC25160	3/8-16X2-1/2 HEX CAP SC
9	4	1392900	WASHER, CHAIN HOLDOWN	36	8	SSSCM10X40	CAP SCREW 10MM X 40MM
10	4	1392901	GUIDE, TENSION ROLLER	37	4	SSSCM5X20	M5-0.8X20,SCREW,SOCKET CA
11	2	1392903	STOP, TENSION ROLLER	38	4	SSSCM5X30	M5-0.8X30,SCREW,SOCKET CA
12	1	1392904	SUPPORT, TENSION ROLLER	39	12	SSSCM6X20	SCREW, SOCKET CAP
13	2	1392908	COVER, TENSION ROLLER BRG	40	6	SSSCM6X25	M6X25 SOC CAP SCREW
14	1	1392913	COVER, TOP LEFT	41	4	SSSCM8X20	M8X20 SOC CAP
15	1	1392914	COVER, TOP RIGHT	42	4	SSSCM8X25	SCREW,SOC CAP,M8X25
16	2	1393466	CHAIN, SINGLE STRAND	43	4	SSSCM8X30	SCREW,SOC CAP,M8X30
17	1	1394146	SUPPORT, WHEEL, ASSY.	44	4	SSSSM5X5C	M5-0.8X5 CUP PT. SS
18	1	1394278	SUPPORT, WHEEL, LEFT	45	18	WWF1/4	WASHER, FLAT, 1/4", COM
19	2	2-059	BLOCK, ROLL HOLDER	46	4	WWF10	WASHER, FLAT, #10, COM
20	2	AA3001F-03	FLOW CONT,INLINE,1/4 LINE	47	20	WWF3/8	WASHER,FLAT,3/8 OR 10MM
21	2	AAC6DP-6	CYLINDER, AIR, DA	48	12	WWF5/16	WASHER,FLAT,5/16
22	2	AAF312	ROD END ALIGNER	49	12	WWFM5	WASHER, FLAT, M5 I.D.
23	2	AAFP18	MUFFLER,1/8 NPT, BRONZ	50	2	WWFS3/8	WASHER,FLAT,SAE,3/8
24	2	AAQME-4-8	ELBOW,QUICK MALE,1/4X1/8	51	18	WWL1/4	WASHER,LOCK,1/4
25	4	BBGER205-25	BEARING,BALL,25MMB,CLAMP	52	8	WWL10	WASHER,LOCK,#10
26	4	BBTRA815	WASHER,THRUST,STEEL 1/2	53	22	WWL3/8	WASHER, LOCK, 3/8
27	2	IID016X096	DOWEL PIN,1/4 X 1-1/2	54	12	WWL5/16	WASHER, LOCK, 5/16

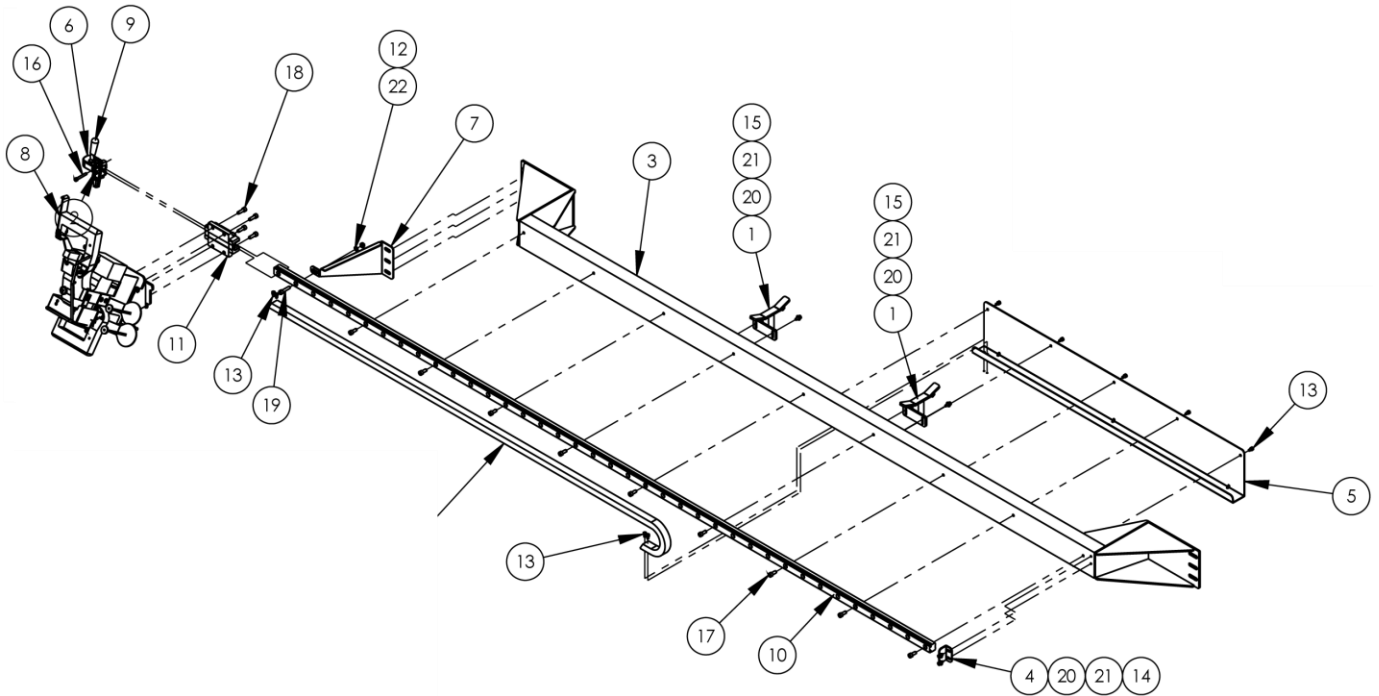

1392580 Bag Closing Mount Assembly

AAC Drawing Number 1392580 Rev 9

NO.	QTY	PART #	DESCRIPTION
1	2	1389066	WLDMT,TICK TRAY SUPPORT
2	1	1389970	STOP BLOCK,30MM RAIL
3	1	1392168	SUPPORT, BAR, BAG CLOSER
4	1	1392600	LIMITER
5	1	1392601	TRACK TRAY
6	1	1392605	END STOP-GUARD
7	1	1392638	BRACKET
8	1	1392959	CLOSER ASSM
9	1	MM331	CLAMP, PULL LATCH
10	1	MMHGR30R3000HN	RAIL,LINEAR, HG 3000MM
11	1	MMHGW30HCZ0HN	LINEAR BEARING
12	1	NNHM8X1.25	M8 X 1.25 HEX NUT
13	9	SSSCM6X10	M6X10 SOC CAP SCREW
14	2	SSSCM6X12	M6X12 SOC CAP SCREW
15	4	SSSCM6X15	M6X15 SOC CAP SCREW
16	1	SSSCM6X45	M6X45 SOC CAP SCREW
17	9	SSSCM8X20	M8X20 SOC CAP
18	4	SSSCM8X25	SCREW,SOC CAP,M8X25
19	1	SSSCM8X35	SCREW,SOC CAP,M8X35
20	6	WWFM6.1	WASHER, FLAT, M6, SAE
21	6	WWLM6	M6 LOCK WASHER
22	1	WWLM8	M8 LOCK WASHER

Page 135

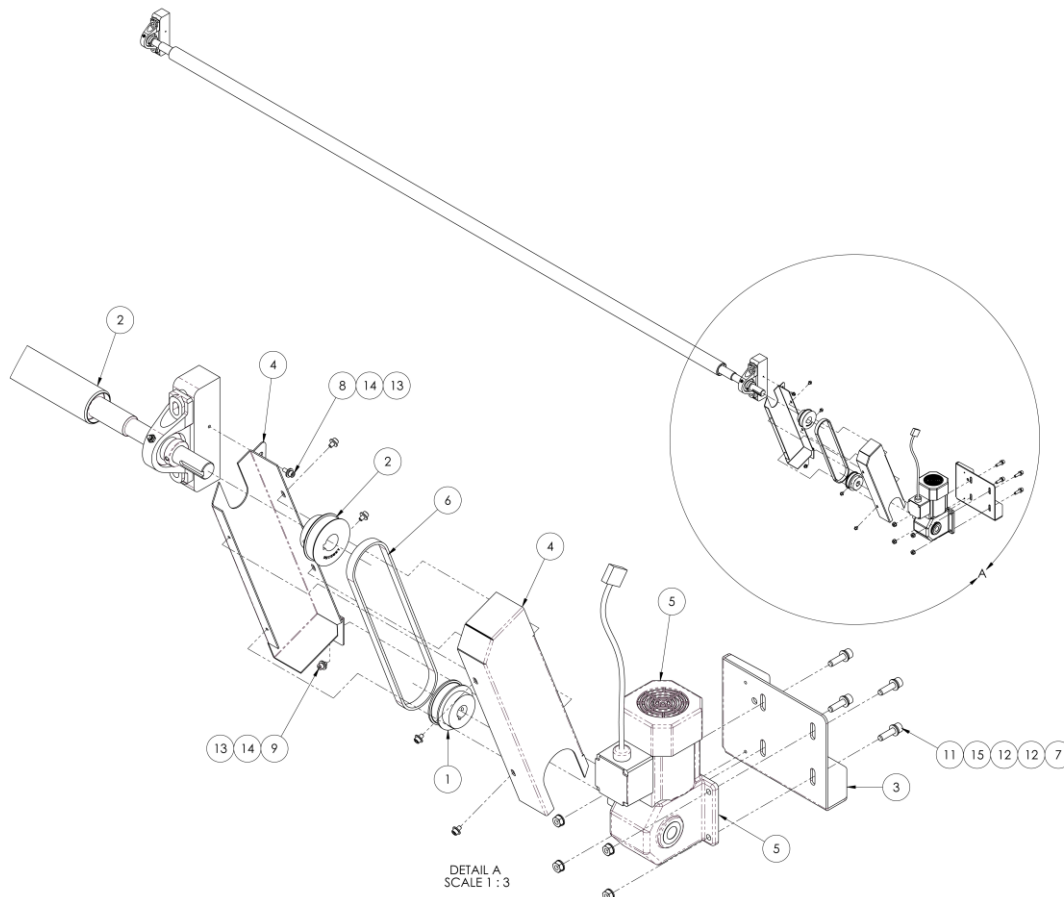

1392897 Pleat Prevention Assembly

AAC Drawing Number 1392897 Rev 1

NO	QTY	PART #	DESCRIPTION
1	1	1961-369	PULLEY, CLUTCH, 20T, 3/8
2	1	1392151	B POLE ASSEMBLY
3	1	1392155	MOUNT, MOTOR
4	1	1392645	GUARD, MOTOR
5	1	1392693	MOTOR ASSY, SPIRAL ROLLER
6	1	GG285L050	BELT, 3/8P, 76T, 1/2W
7	4	NNHM8X1.25	M8 X 1.25 HEX NUT
8	1	SSSC98032	10-32X1/2, SOC CAP
9	1	SSSCM5X8	SCREW, SOC CAP, M5-0.8 X 8
10	1	SSSCM5X16	M5-0.8X16, SCREW, SOCKET CA
11	4	SSSCM8X30	SCREW, SOC CAP, M8X30
12	8	WWFM8	WASHER, FLAT, M8 I.D.
13	2	WWFS10	WASHER, FLAT, #10, SAE
14	2	WWL10	WASHER, LOCK, #10
15	4	WWLM8	M8 LOCK WASHER

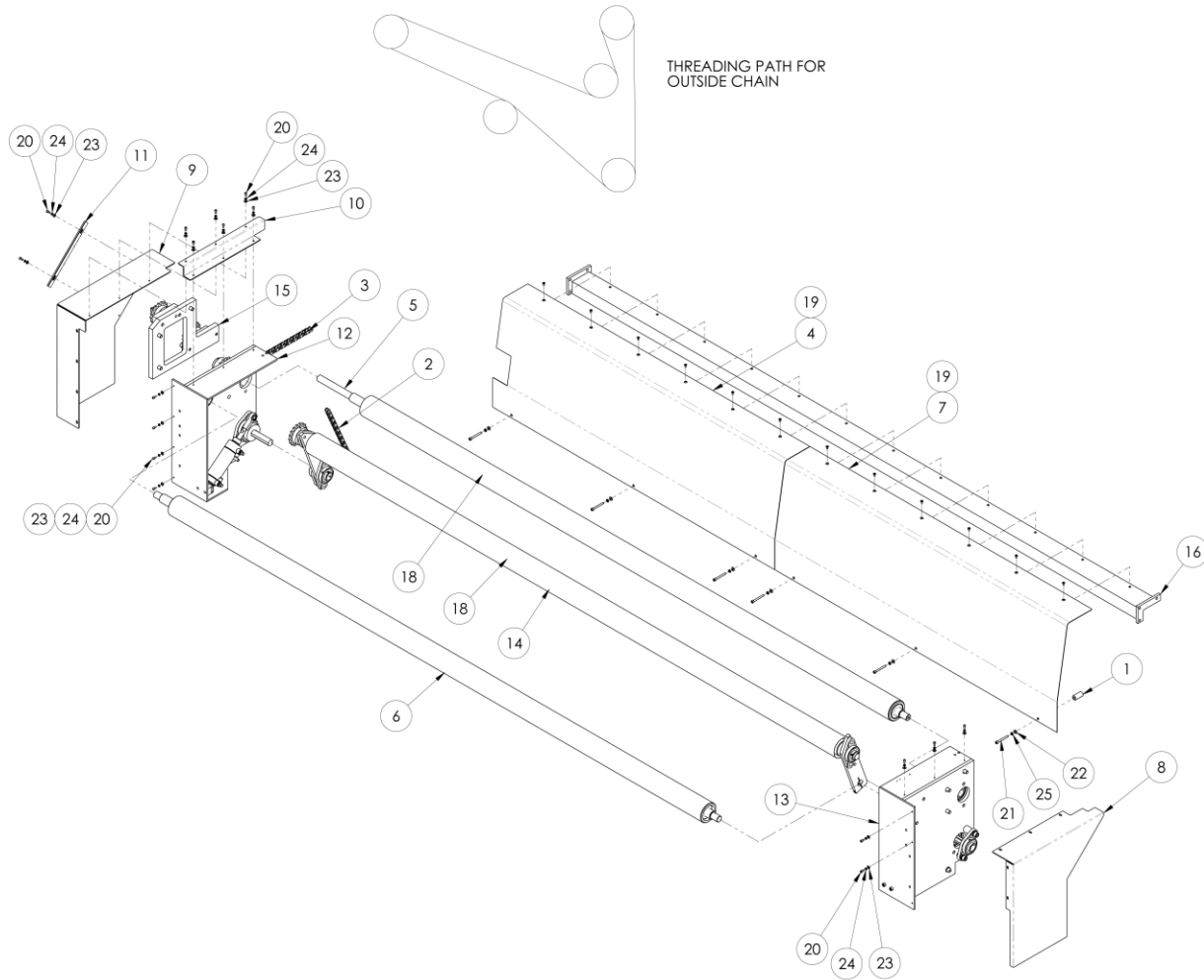

1392978 Front Feed Assembly

AAC Drawing Number 1392978 Rev 5

NO	QTY	PART	DESCRIPTION	NO	QTY	PART	DESCRIPTION
1	6	1389433	SPACER,3/4X1.5X.38ID	14	1	1392937	FRONT FEED ROLLER SUB-ASY
2	1	1392102	CHAIN, INSIDE, 24.375 L	15	1	1392938	LEFT SPROCKET IDLER ASY
3	1	1392144	CHAIN, OUTSIDE, 81.875 L	16	1	2-057	CLOTH PLATE
4	1	1392172	GUIDE PLATE, INFEED, LEFT	17	1	5-045	CLOTH PLATE SUPPORT ARM
5	1	1392816	ROLLER, INPUT, MODIFIED	18	2	MM050526	TAPE, SANDPAPER, 240 GRIT
6	1	1392879	ROLLER, INPUT	19	12	SSFCM5X10	SCREW, FLAT ALLEN CAP
7	1	1392909	GUIDE PLATE, INFEED, RIGHT	20	17	SSSCM5X10	SCREW, SOC CAP, M5-0.8 X 10
8	1	1392921	GUARD, FRONT ROLLER, RT	21	6	SSSCM6X55	M6X55 SOC CAP SCREW
9	1	1392925	GUARD, FRONT ROLLER, LT	22	6	WWFM6.1	WASHER, FLAT, M6, SAE
10	1	1392933	LEFT GUARD INSERT	23	17	WWFS10	WASHER, FLAT, #10, SAE
11	1	1392934	LEFT GUARD BRACE	24	17	WWLM5	M5 LOCK WASHER
12	1	1392935	FRONT LEFT ROLLER SUB-ASY	25	6	WWLM6	WASHER, LOCK, M6
13	1	1392936	FRONT RT ROLLER SUB-ASY				

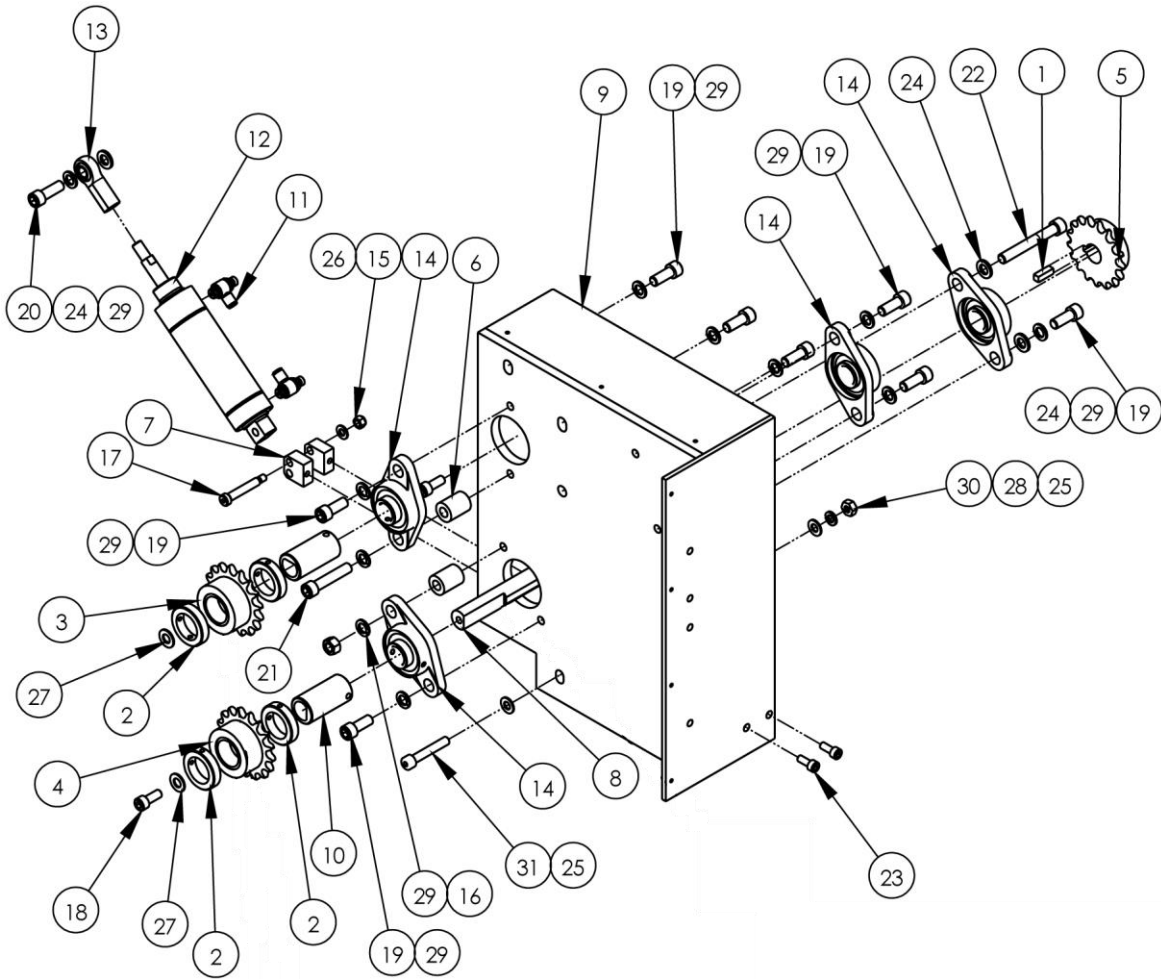

1392935 Front Left Roller Sub-Assembly

AAC Drawing Number 1392935 Rev 7

NO.	QTY	PART #	DESCRIPTION	NO.	QTY	PART #	DESCRIPTION
1	1	1392018	KEY, 8 MM X 25 MM	17	1	SSAS024128	3/8 X 2 X 5/16-18 SHLD, BOLT
2	4	1392278	COLLAR, CLUTCH BEARING	18	2	SSSCM10X25	M10-1.5 X 25 SOC CAP
3	1	1392826	DRIVE SPROCKET ASBLY, RH	19	8	SSSCM12X30	M12-1.75 X 30 SOC CAP
4	1	1392865	DRIVE SPROCKET ASBLY,LH	20	1	SSSCM12X35	M12-1.75 X 35 SOC CAP
5	1	1392871	STEEL SPROCKET,17T,5/8P	21	1	SSSCM12X60	M12-1.75 X 60 SOC CAP
6	2	1392883	SPACER, FLANGE BEARING	22	1	SSSCM12X90	STUD, M12X40, W/ SHOULDER
7	2	1392886	MOUNT, CYLINDER BASE	23	2	SSSCM8X20	M8-1.25 X 20 SOC CAP
8	1	1392890	SHAFT, PIVOT,25MM	24	3	WWFM12	12MM FLAT WASHER
9	1	1392891	LEFT CARRIAGE FRAME	25	2	WWFS3/8	WASHER, FLAT, 3/8
10	2	4-039	ADAPTER, CLUTCH BEARING	26	1	WWFS5/16	WASHER, FLAT, 5/16
11	2	AA198RA404U	FLOW CONTROL,1/4PTX1/4	27	2	WWFS7/16	7/16 FW
12	1	AAC313DXP	CYLINDER,AIR,2"BORE,3"STK	28	1	WWL3/8	3/8 LW
13	1	BBAW-8Z	BEARING,ROD END,FEMALE	29	11	WWLM12	M12 LOCK WASHER
14	4	BBUCFL205	BEARING, FLANGE UCFL	30	1	NNHM10X1.5	NUT,HEX,M10X1.5
15	1	NNE5/16-18	NUT,ELASTIC LOCK,5/16-18	31	1	SSSCM10X35	CAP SCREW 10MM X 55MM
16	1	NNHM12X1.75	M12 X 1.75 HEX NUT				

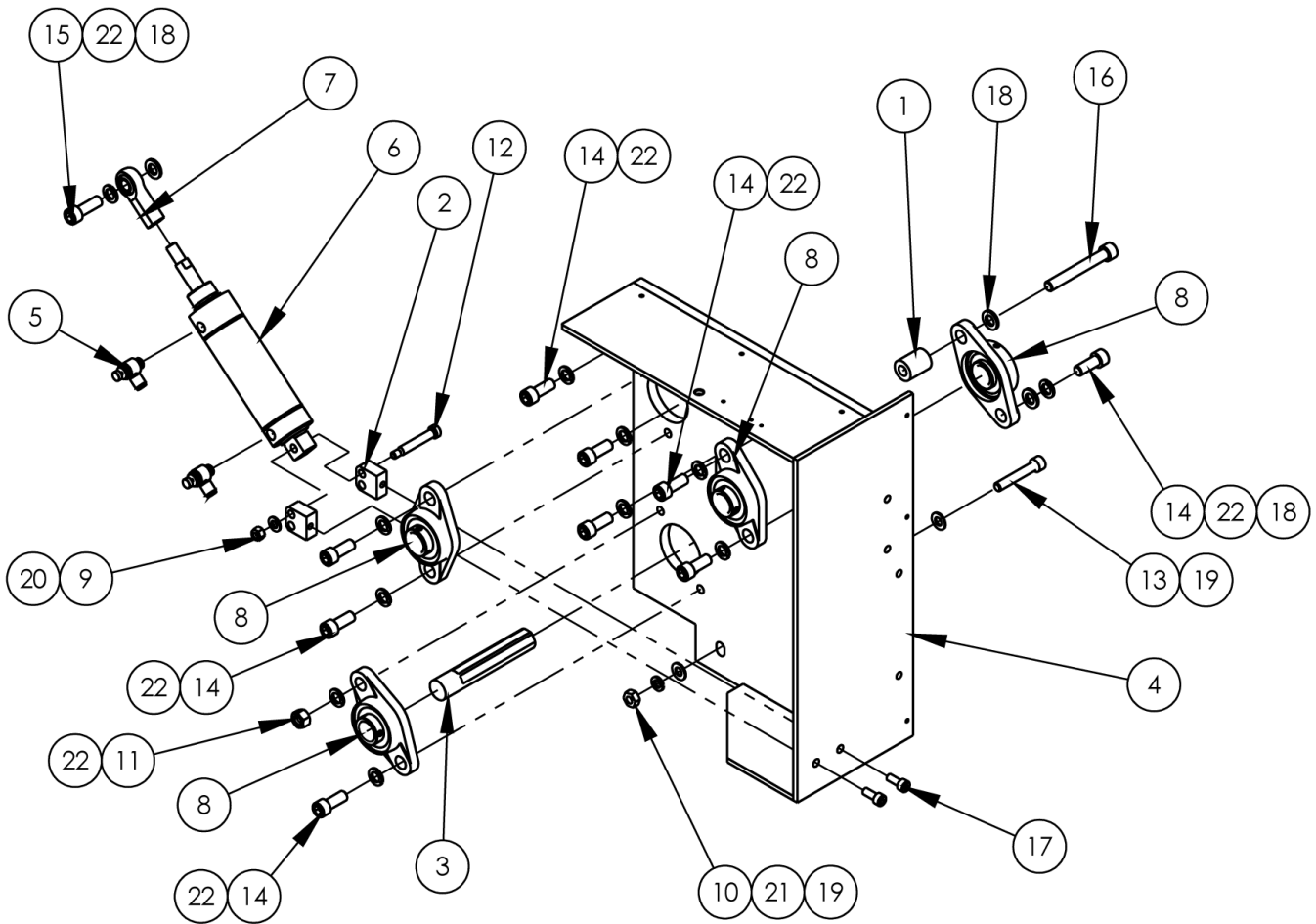

1392936 Front Right Roller Sub-Assembly

AAC Drawing Number 1392936 Rev 5

NO.	QTY	PART #	DESCRIPTION	NO.	QTY	PART #	DESCRIPTION
1	1	1392883	SPACER, FLANGE BEARING	12	1	SSAS024128	3/8 X 2 X 5/16-18 SHLD, BOLT
2	2	1392886	MOUNT, CYLINDER BASE	13	1	SSSCM10X35	CAP SCREW 10MM X 55MM
3	1	1392889	SHAFT, PIVOT,25MM	14	9	SSSCM12X30	M12-1.75 X 30 SOC CAP
4	1	1392892	RIGHT CARIAGE FRAME	15	1	SSSCM12X35	M12-1.75 X 35 SOC CAP
5	2	AA198RA404U	FLOW CONTROL,1/4PTX1/4	16	1	SSSCM12X90	STUD, M12X40, W/ SHOULDER
6	1	AAC313DXP	CYLINDER,AIR,2"BORE,3"STK	17	2	SSSCM8X20	M8-1.25 X 20 SOC CAP
7	1	BBAW-8Z	BEARING,ROD END,FEMALE	18	3	WWFM12	12MM FLAT WASHER
8	4	BBUCFL205	BEARING, FLANGE UCFL	19	2	WWFS3/8	WASHER, FLAT, 3/8
9	1	NNE5/16-18	NUT,ELASTIC LOCK,5/16-18	20	1	WWFS5/16	WASHER, FLAT, 5/16
10	1	NNHM10X1.5	NUT,HEX,M10X1.5	21	1	WWL3/8	3/8 LW
11	1	NNHM12X1.75	M12 X 1.75 HEX NUT	22	11	WWLM12	M12 LOCK WASHER

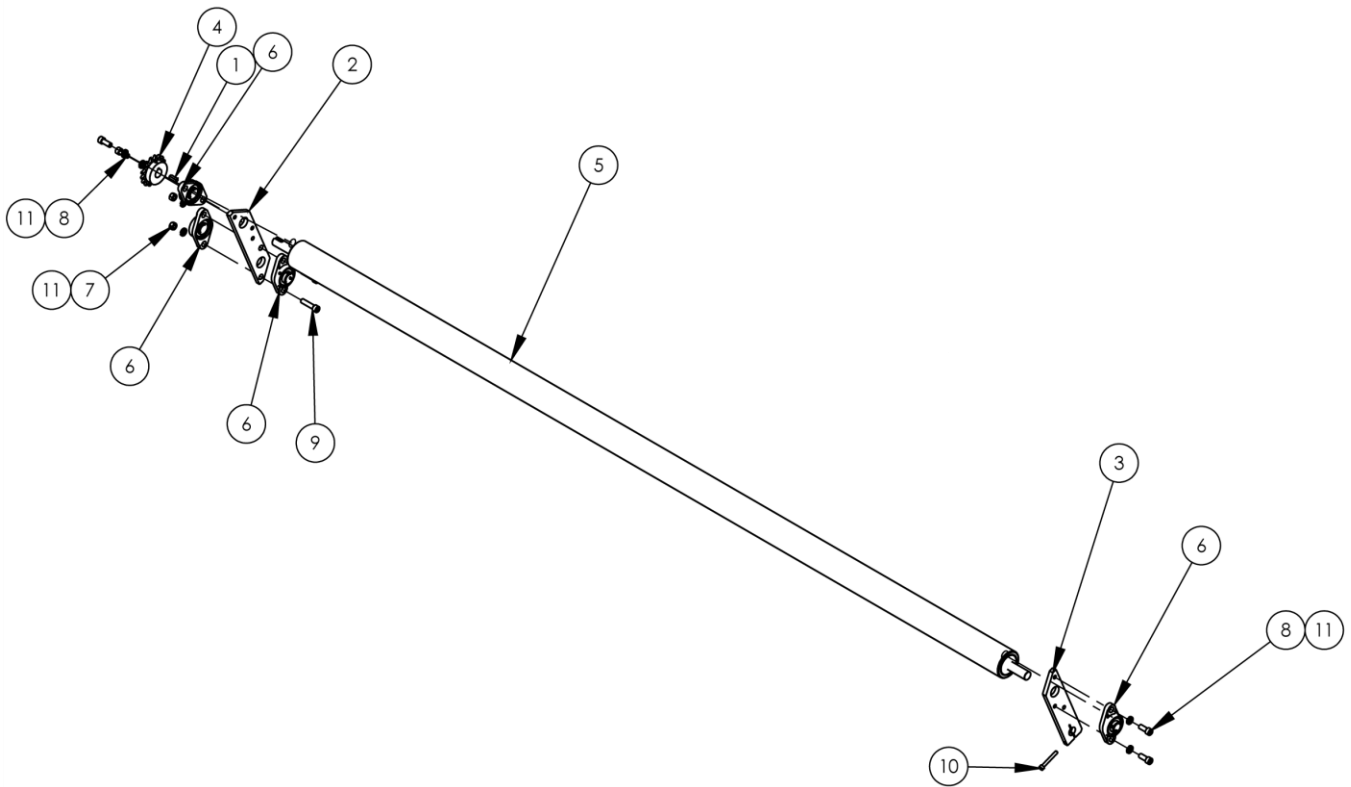

1392937 Front Feed Roller Sub-Assembly

AAC Drawing Number 1392937 Rev 1

NO.	QTY	PART #	DESCRIPTION
1	1	1392018	KEY, 8 MM X 25 MM
2	1	1392869	SUPPORT LINK, BEARING
3	1	1392870	SUPPORT LINK, BEARING
4	1	1392871	STEEL SPROCKET,17T,5/8P
5	1	1392872	ROLLER,DRIVEN,FRONT
6	4	BBUCFL205	BEARING, FLANGE UCFL
7	2	WWFM12	WASHER, FLAT, M12 I.D.
8	2	NNHM12X1.75	NUT,HEX,M12
9	1	SSHCM8X60	SCREW,HEX CAP M8X60
10	6	WWL1/2	1/2 LOCK WASHER
11	4	SSSCM12X30	SCREW, SOC CAP, M12 X 30
12	2	SSSCM12X60	SCREW, M12 X 50

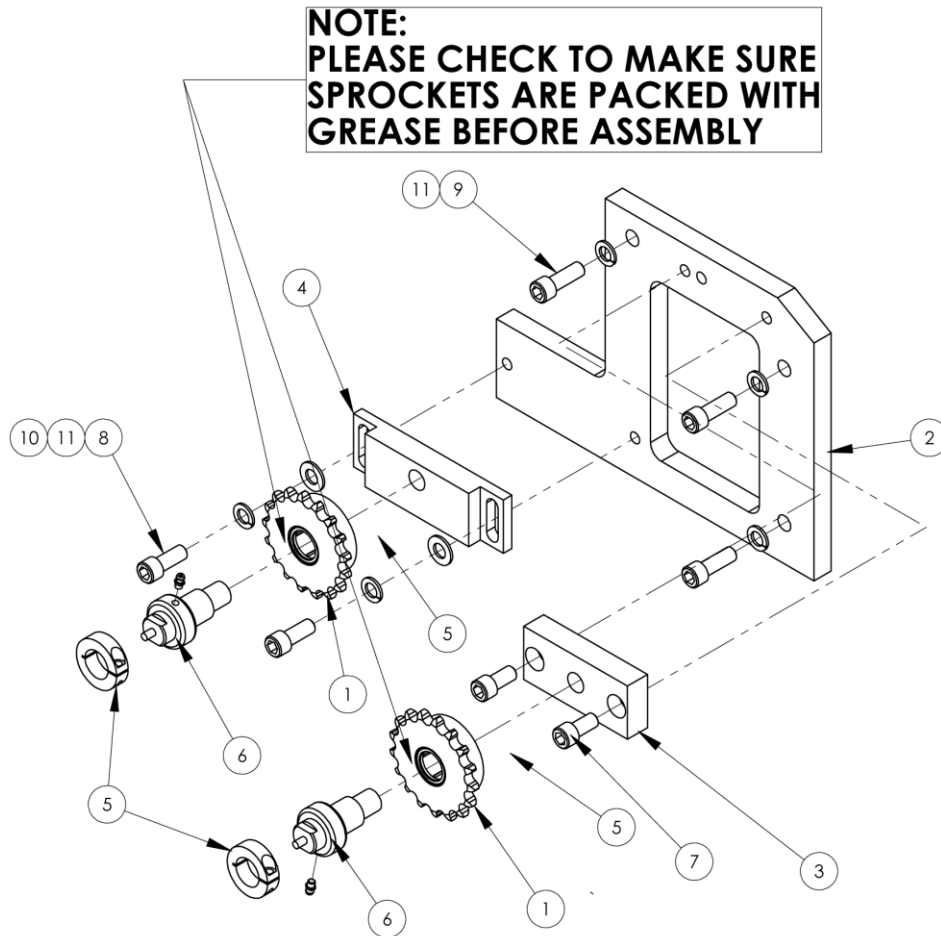

1392938 Left Sprocket Idler Assembly

AAC Drawing Number 1392938 Rev 5

NO	QTY	PART #	DESCRIPTION
1	2	1388773	IDLER SPROCKET ASSEMBLY
2	1	1392820	PLATE,ADAPTOR,BEARING
3	1	1392853	SHAFT MOUNT, M20X2.5
4	1	1392867	SHAFT MOUNT, M20X2.5
5	4	CCCL16F	COLLAR,1" CLAMP TYPE
6	2	MMN2	TIGHTENER SHAFT,1"DIA
7	2	SSSCM12X25	SCREW , M12 X 25
8	2	SSSCM12X30	SCREW , SOC CAP, M12 X 30
9	3	SSSCM12X35	SCREW , M12 X 35
10	2	WWFM12	WASHER, FLAT, M12 I.D.
11	5	WWLM12	M12 LOCK WASHER

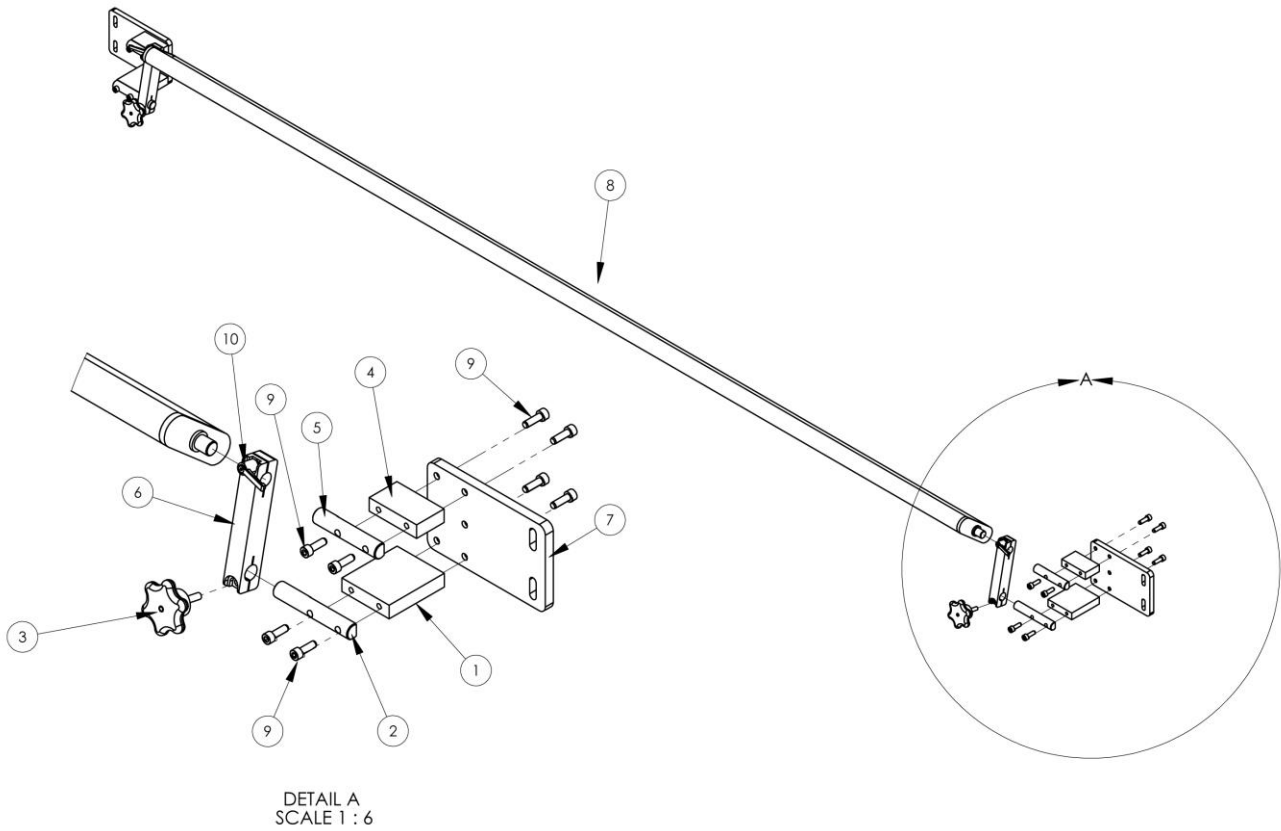

1393922 Tensioner Assembly

AAC Drawing Number 1393922 Rev 3

NO	QTY	PART #	DESCRIPTION
1	2	1389188	SPACER,3/4 X 3 X 3-1/2
2	2	1389189	SHAFT,PIVOT,TENSION BARS
3	2	1389469	KNOB,THREADED,M8
4	2	1389522	SPACER,3/4 X 3 X 1-3/4
5	2	1389617	ROD,STOP,TENSION BARS
6	2	1393927	ARM,PIVOT
7	2	1393928	PLATE,TENSION BAR MTG
8	1	3-017	FRONT TENSIONER MOD
9	16	SSSCM8X25	SCREW ,SOC CAP,M8X25
10	2	TTH6324K63	HANDLE, THREADED, M8 X 20 MM

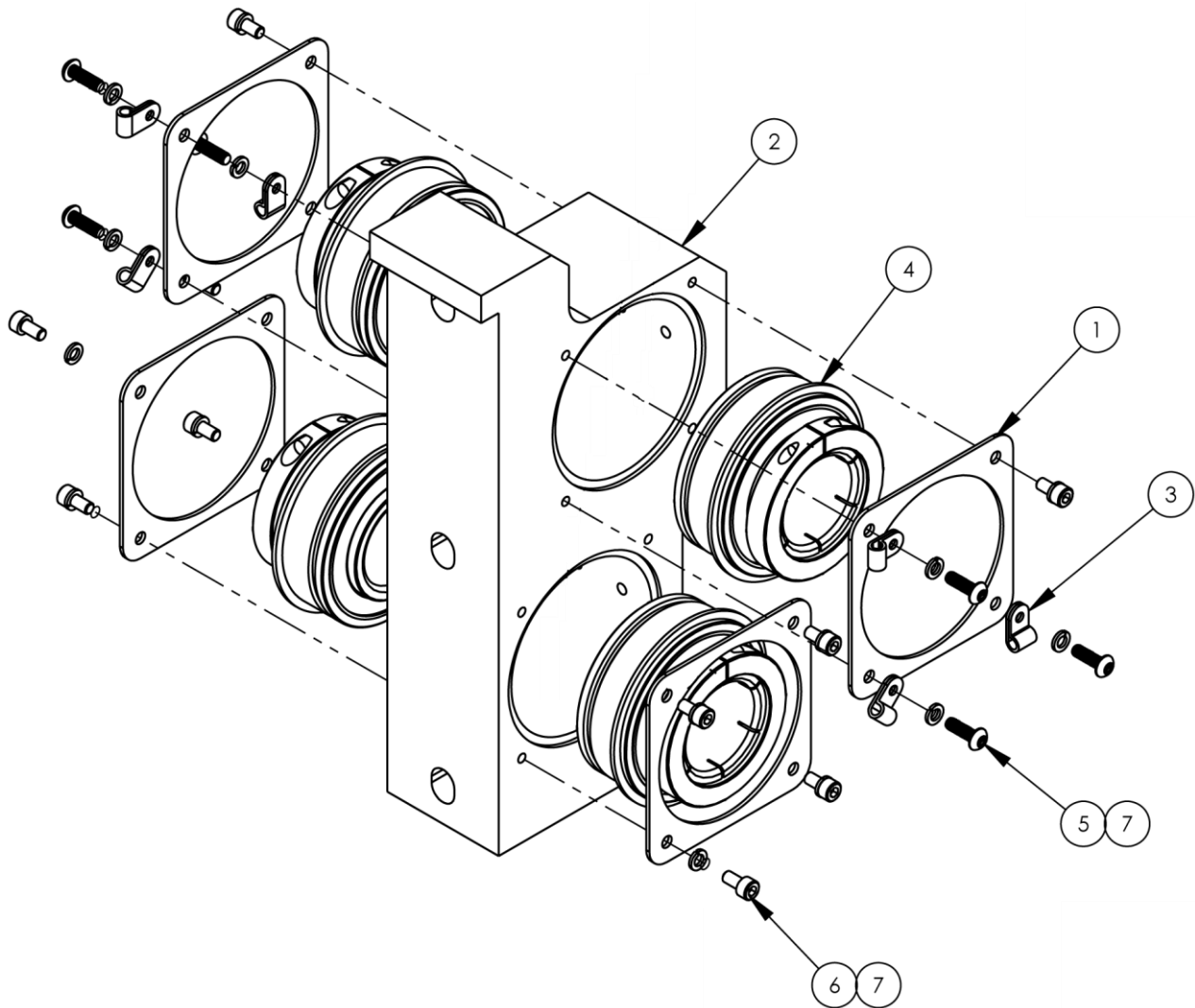

1389023 Center Insert Mount Bearing

AAC Drawing Number 1389023 Rev 2

NO.	QTY	PART #	DESCRIPTION
1	4	1393993	RETAINER, CARTRIDGE BRG
2	1	1393995	MOUNT, INSERT BRG, CENTER
3	6	AAF3/16	CLAMP, BLACK PLASTIC
4	4	BBER208TMC	BEARING,INSERT,SKWEZLOC
5	6	SSBCM5X16	M5-0.8 X 16 BUTTON CAP
6	10	SSSCM5X10	M5-0.8 X 10 SOC CAP
7	16	WWLM5	M5 LOCK WASHER

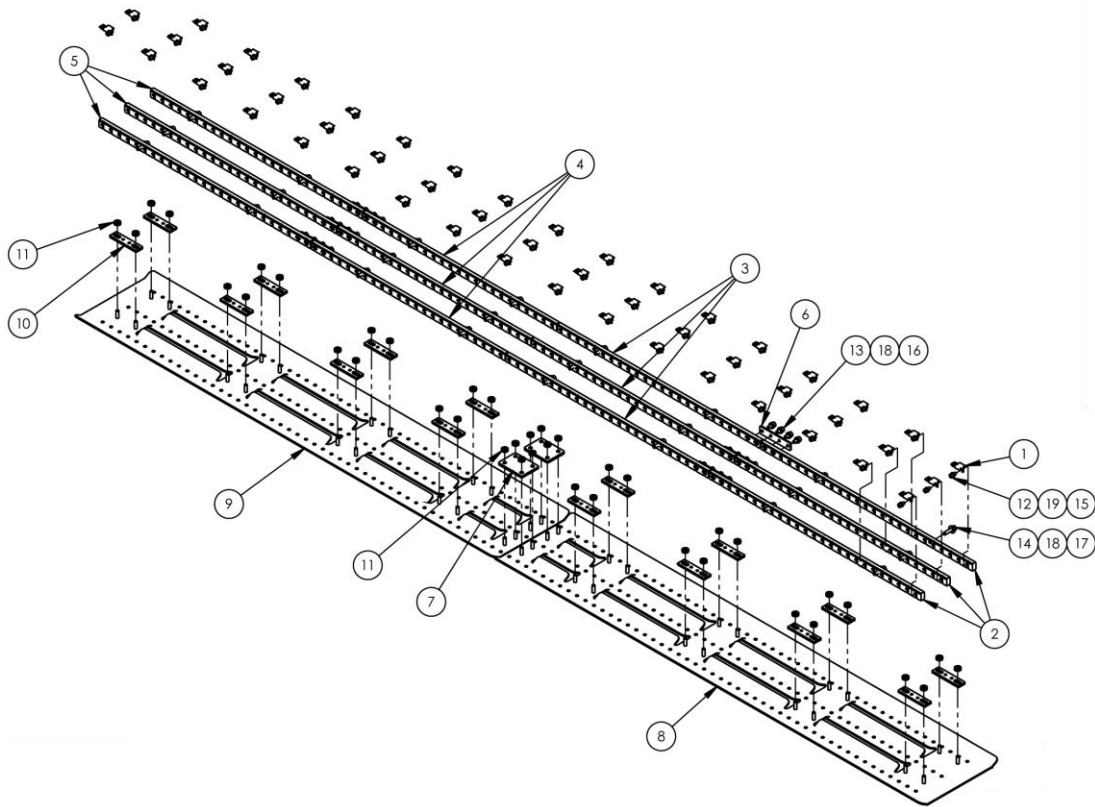

1389509 Presser Feet and Needle Bars

AAC Drawing Number 1389509 Rev 1

NO.	QTY	PART #	DESCRIPTION
1	50	1389031	EYELET, NEEDLE THREAD, 19M
2	3	1393860	NEEDLE CLAMP, RT OUTSIDE
3	3	1393861	NEEDLE CLAMP, R. MIDDLE
4	3	1393900	NEEDLE CLAMP, L. MIDDLE
5	3	1393901	NEEDLE CLAMP, LEFT
6	6	1393902	PLATE, WASHER
7	2	1393921	PLATE, SPLICE, FOOT
8	1	1393925	PRESSER FOOT, RH
9	1	1393926	PRESSER FOOT, LH
10	16	1393952	PLATE, ADAPTER
11	40	1393953	WASHER, HEAVY
12	50	SSSCM5X10	SCREW, SOC CAP, M5-0.8 X 10
13	24	SSSCM6X12	M6X12 SOC CAP SCREW
14	30	SSSCM6X25	M6X25 SOC CAP SCREW
15	50	WWFM5	WASHER, FLAT, M5 I.D.
16	24	WWFM6	WASHER, FLAT, M6, SAE
17	30	WWFS1/4	WASHER, FLAT, SAE, 1/4
18	54	WWL1/4	WASHER, LOCK, 1/4
19	50	WWLM5	M5 LOCK WASHER

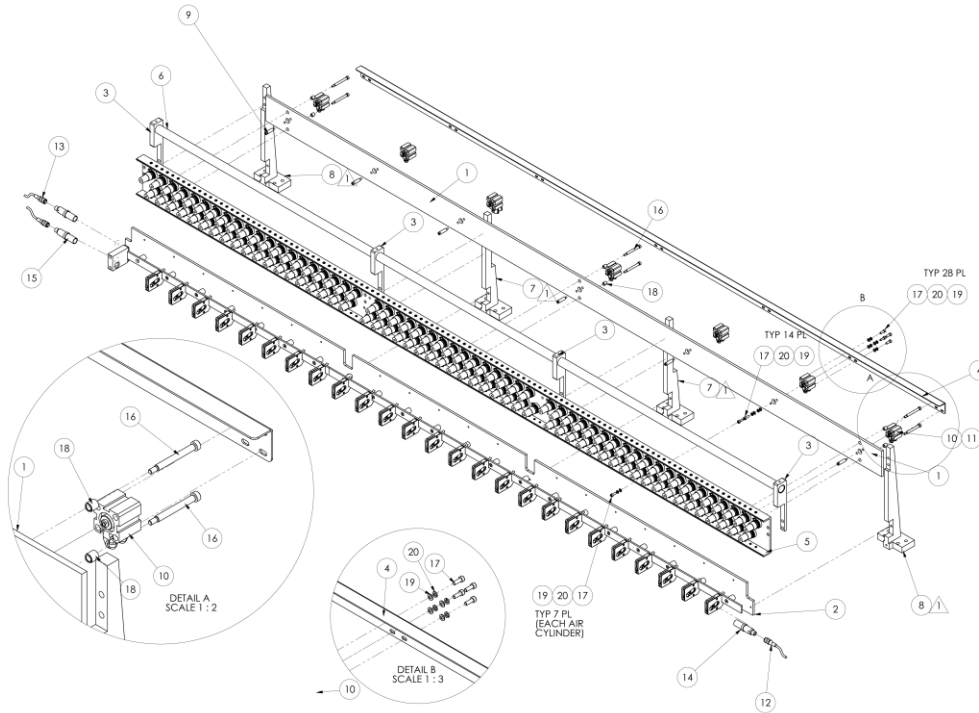

1392124 Needle Thread Mount Assembly

AAC Drawing Number 1392124 Rev 11

NO	QTY	PART #	DESCRIPTION
1	1	1388903	PLATE, NESION RELEASE, TOP
2	1	1389274	DUAL THD BK DETECTOR ASM
3	4	1389279	BRACKET, THREAD ROD
4	1	1389460	PLATE, TENSION RELEASE
5	1	1392291	GUIDE, THREAD TENSION ASM
6	1	1392359	TUBE, THREAD GUIDE (1-046)
7	2	1392668	SUPPORT, THREAD GUIDE
8	2	1392670	SUPPORT, THREAD GUIDE
9	7	1393862	EXTENSION, SHAFT, CYL
10	7	AACSDA20X10	CYLINDER
11	14	AAQME-4-10	ELBOW, QUICK MALE
12	1	FFRK44T-4	CABLE, EYE, 12', NO END
13	2	FFRK44T-6	CABLE, EYE, 19', NO END
14	1	FFS18SN6RQ	EYE, OPPOSED, RCVR, NPN, IR
15	2	FFS186EQ	EYE, OPPOSED, XMIT, IR LED,
16	6	SSAS016128	SHOULDER BOLT 1/4 X 2.0L
17	49	SSSCM5X14	SCREW, SOC CAP, M5-0.8 X 14
18	6	UUAA304-7	BEARING, BRONZE, .250ID
19	49	WWFM5	WASHER, FLAT, M5 I.D.
20	49	WWLM5	M5 LOCK WASHER

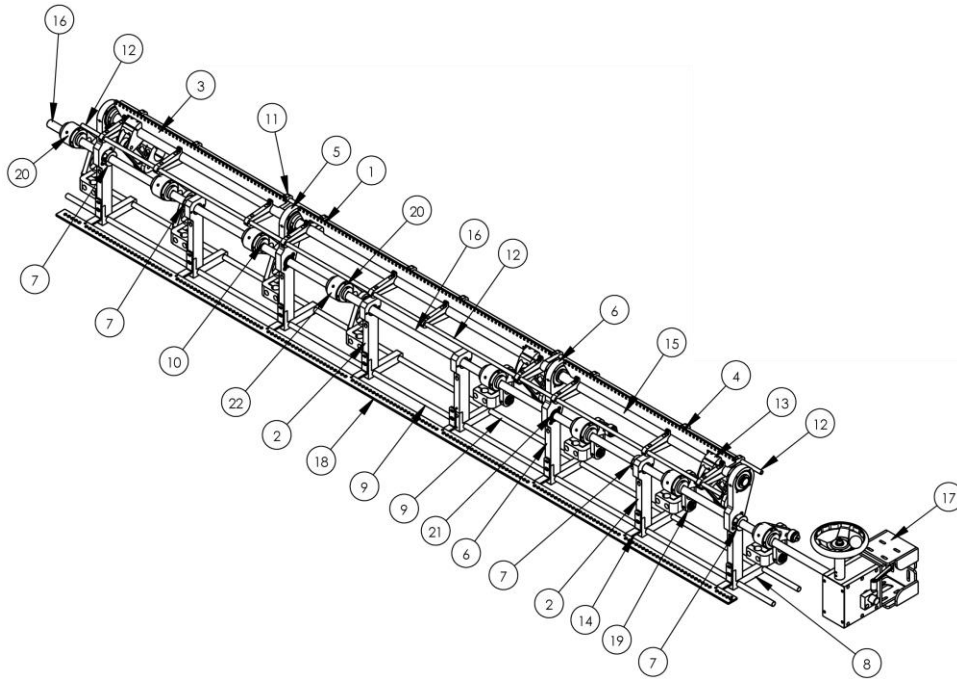

1393864 Foot Adjustment Assembly

AAC Drawing Number 1393864 Rev 6

NO	QTY	PART #	DESCRIPTION
1	1	1389003	BAR,EYELET
2	4	1389004	BLOCK,BEARING,SHORT
3	1	1389014	BAR,EYELET,SHORT,LEFT
4	1	1389015	BAR,EYELET,SHORT,RIGHT
5	2	1389199	BEARING,RIGHT HAND
6	2	1389200	BEARING LEFT HAND
7	4	1389524	CLAMP COLLAR,M20,W/SHLDR
8	8	1392019	BLOCK,THREAD ROD
9	2	1392066	THREAD GUIDE ROD, FRONT
10	8	1392686	KEY, 6mm
11	10	1392811	BAR,CLAMP,BUTTERFLY
12	2	1392844	TUBE,BUTTERFLY
13	3	1392846	BUTTERFLY DRIVE ASSY
14	8	1392847	BRKT,EYELET BAR MTG
15	1	1392849	SHAFT,BUTTERFLY,25MM
16	1	1393865	SHAFT,FOOTLIFT ADJUST
17	1	1393875	FOOTLIFT ADJUST KNOB ASSY
18	1	1393955	BAR,EYELET
19	4	1393958	FOOTLIFT LINKAGE, RIGHT
20	4	1393957	FOOTLIFT LINKAGE, LEFT
21	5	BBGE20ES2RS	BEARING,SPHERICAL PLAIN,2
22	8	SSBCM6X12	SCREW,BUT CAP 6MMX12

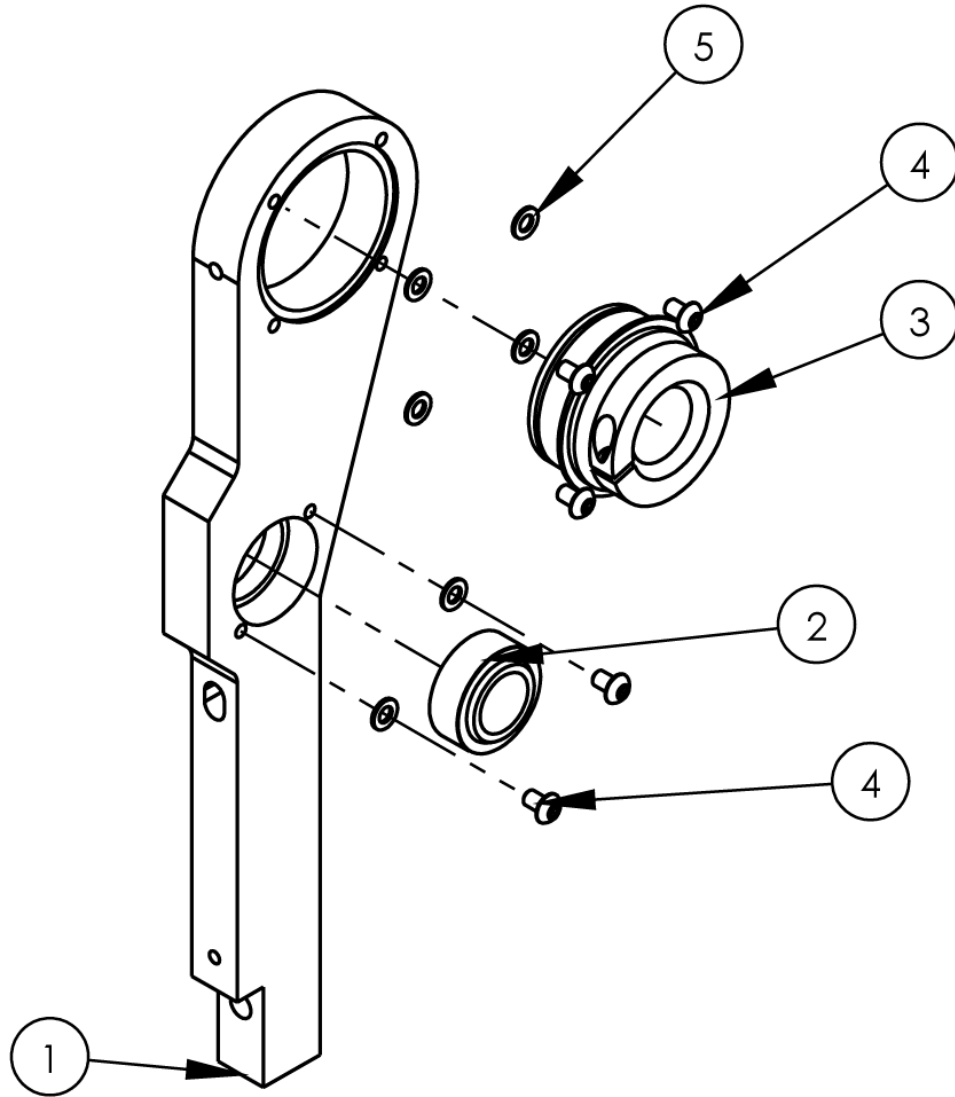

1389199 Right Hand Bearing

AAC Drawing Number 1389199 Rev 1

NO.	QTY	PART #	DESCRIPTION
1	1	1392815	BLOCK, BEARING
2	1	BBGE20ES2RS	BEARING, SPHERICAL PLAIN, 2
3	1	BBGER205-25	BEARING, BALL, 25MM B, CLAMP
4	6	SSBCM5X8	M5 X 8MM BUT HEAD
5	6	WWFM5	WASHER, FLAT, M5 I.D.

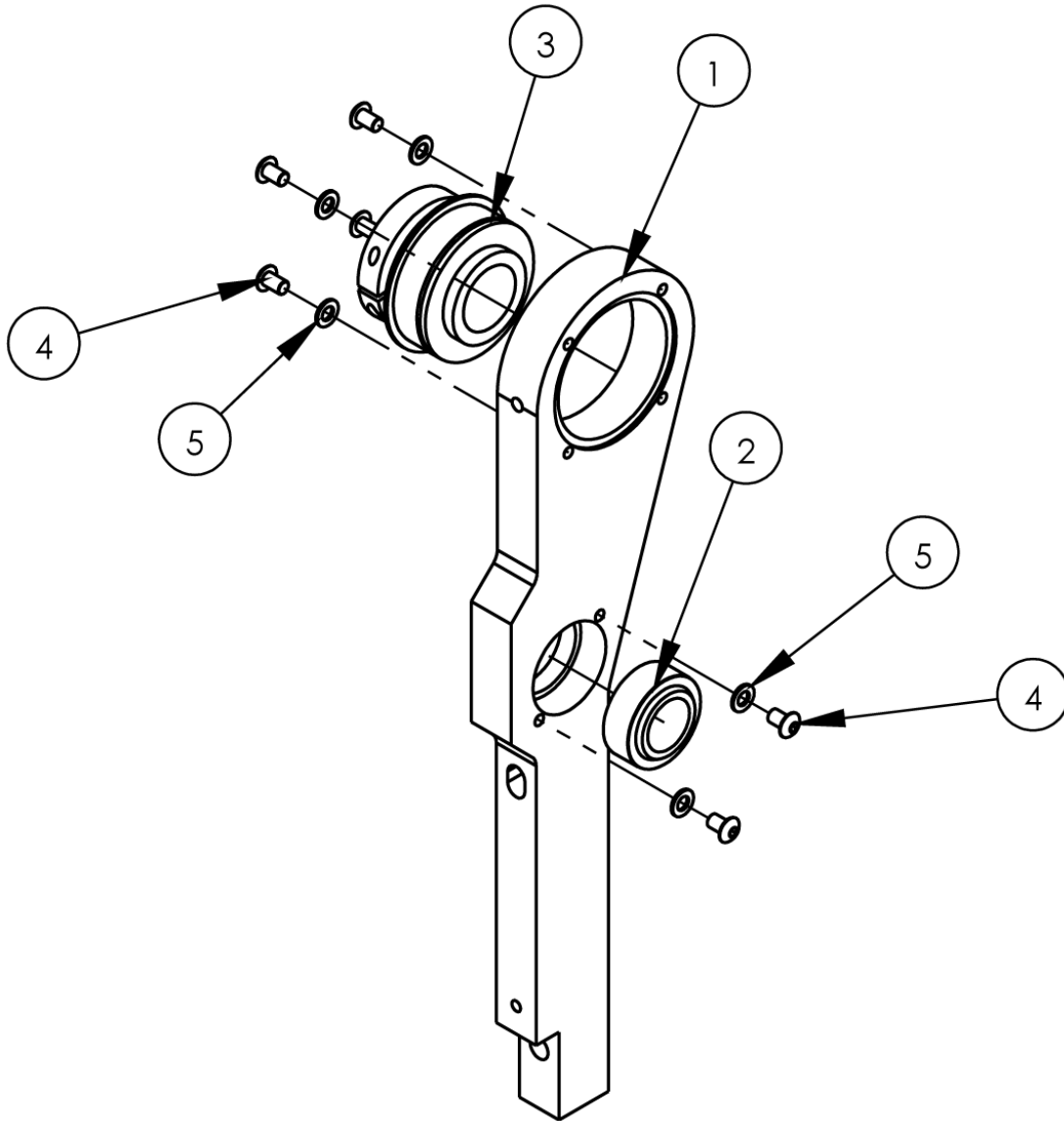

1389200 Left Hand Bearing

AAC Drawing Number 1389200 Rev 0

NO.	QTY	PART #	DESCRIPTION
1	1	1392815	BLOCK, BEARING
2	1	BBGE20ES2RS	BEARING, SPHERICAL PLAIN, 2
3	1	BBGER205-25	BEARING, BALL, 25MMB, CLAMP
4	6	SSBCM5X8	SCREW, BUTTON CAP
5	6	WWFM5	WASHER, FLAT, M5 I.D.

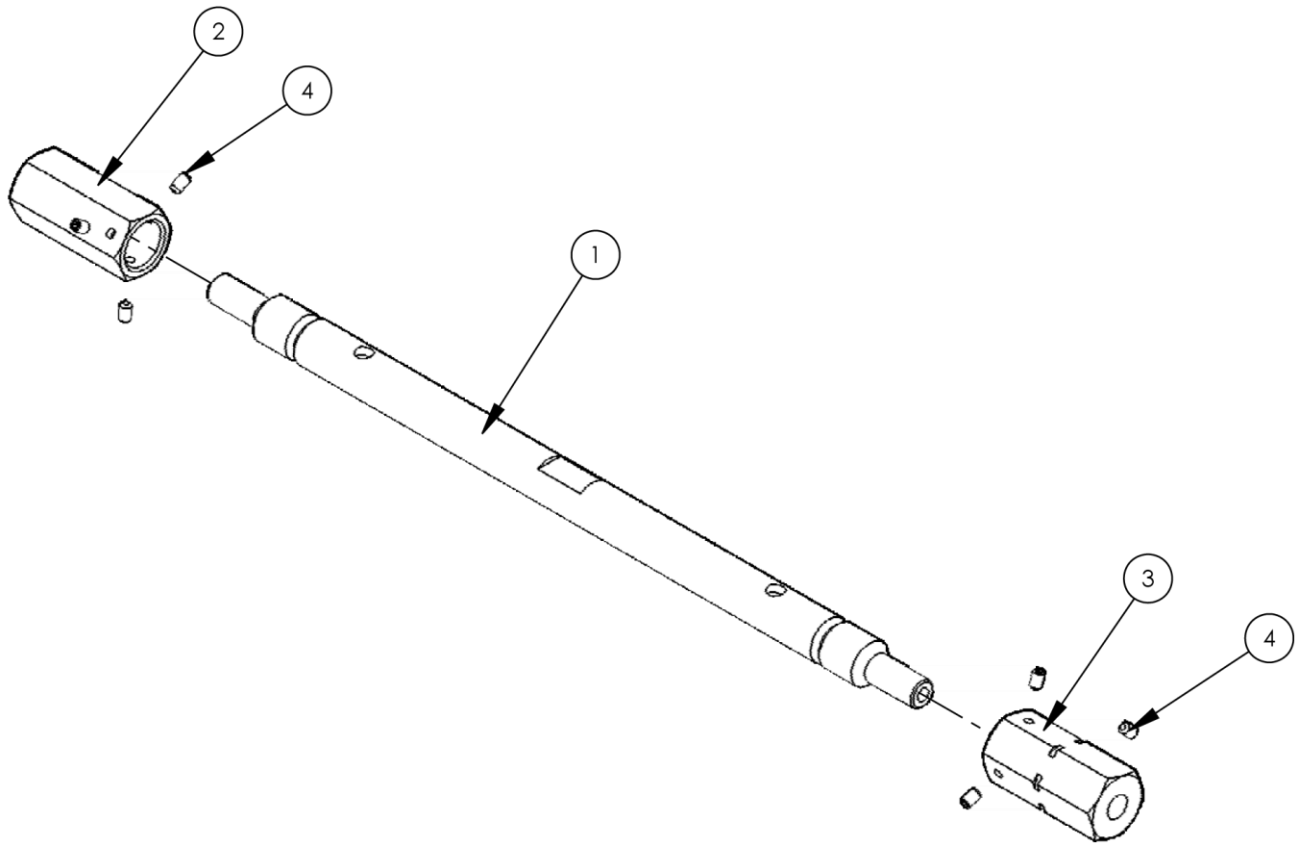

1393986 Tie-Rod Assembly

AAC Drawing Number 1393986 Rev 1

NO.	QTY	PART #	DESCRIPTION
1	1	1392719	TIE ROD WELDMENT,NDL
2	1	1393984	NUT,TIE-ROD, RH THREAD
3	1	1393985	NUT,TIE-ROD, LH THREAD
4	6	SSSSM6X10	M6 SET SCREW, 10MM L

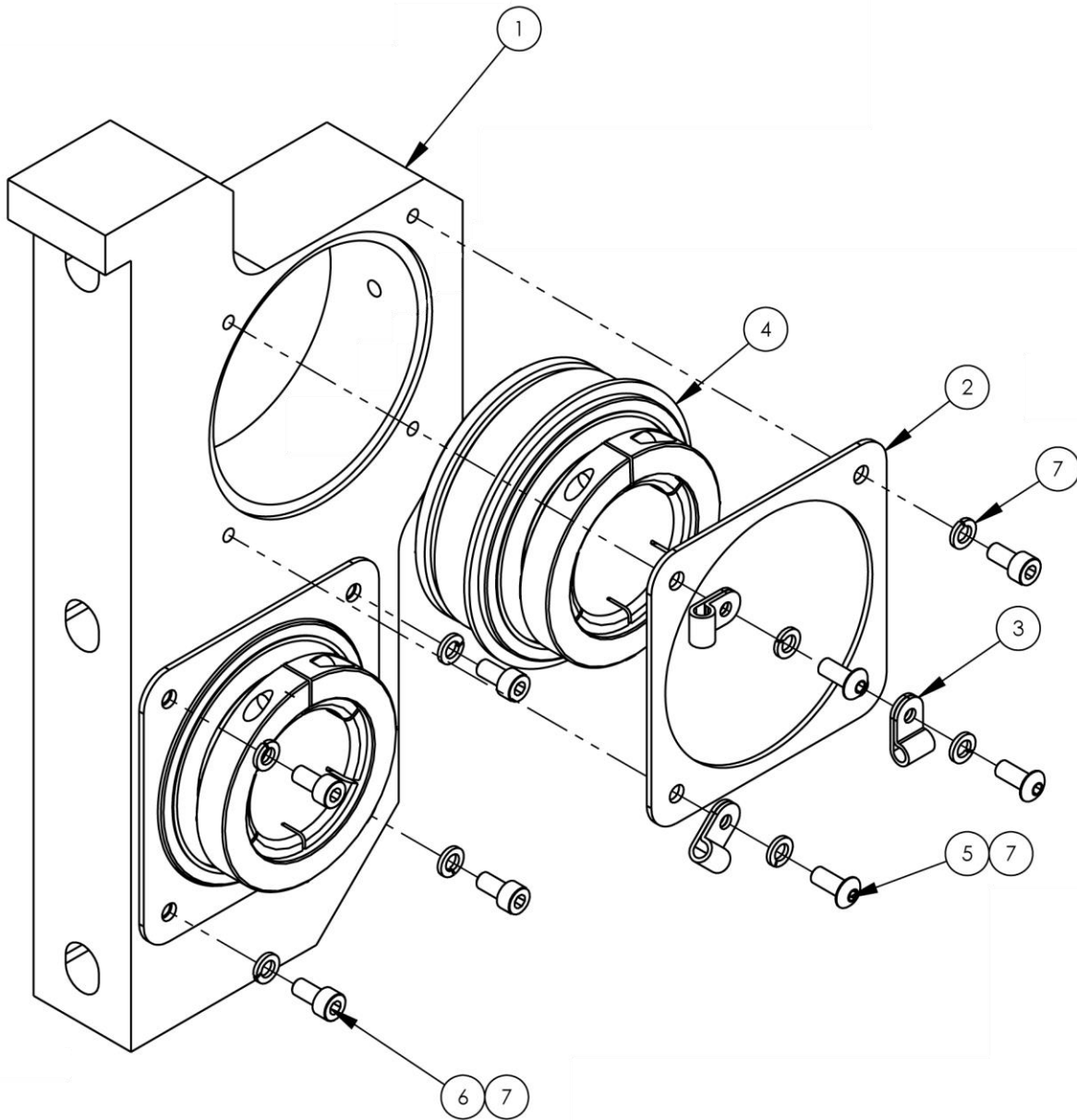

1393994 LH Insert Mount Bearing Assembly

AAC Drawing Number 1393994 Rev 2

NO.	QTY	PART #	DESCRIPTION
1	1	1393992	MOUNT, INSERT BEARING
2	2	1393993	RETAINER, CARTRIDGE BRG
3	3	AAF3/16	CLAMP, BLACK PLASTIC
4	2	BBER208TMC	BEARING, INSERT, SKWEZLOC
5	3	SSBCM5X12S	SCREW, BUTTON CAP, S/S
6	5	SSSCM5X10	SCREW, SOC CAP, M5-0.8 X 10
7	8	WWLM5	M5 LOCK WASHER

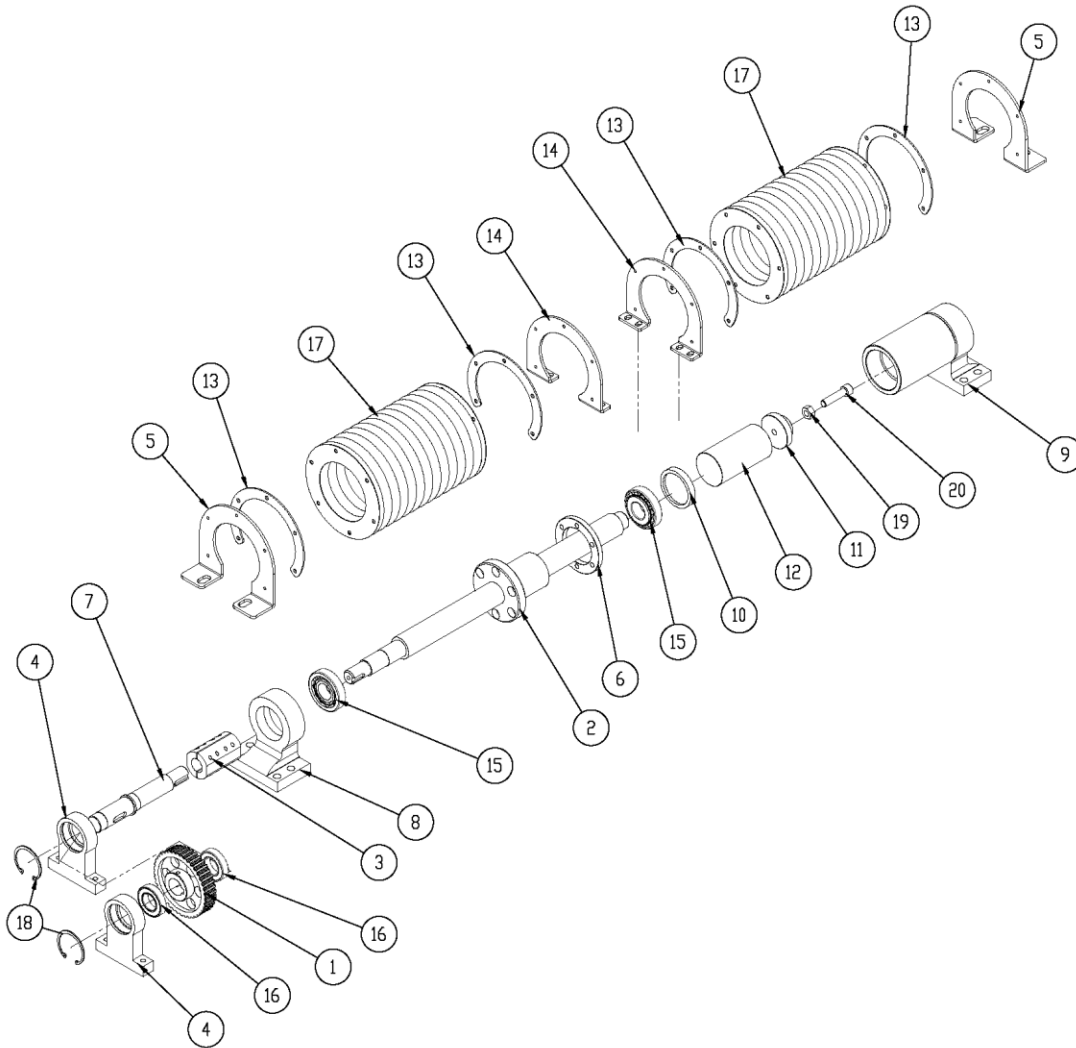

1388673 12in Leadscrew Drive

AAC Drawing Number 1388673 Rev 5

NO.	QTY	PART#	DESCRIPTION	NO.	QTY	PART#	DESCRIPTION
1	1	1-033	PULLEY, TIMING, 40T	11	1	1389298	BEARING THRUST NUT
2	1	4-086	LEAD SCREW,1392C	12	1	1389299	PUSH ROD,61MM DIA
3	1	4-087	COUPLING, WORM GEAR	13	4	1389301	BRACKET, BELLOW, 4.25 ID
4	2	4-088	MOUNT, ROLLER BEARING	14	2	1389302	BRACKET, BELLOW, 4.25 ID
5	2	1388672	BRKT,BELLOWS,NEW 1392	15	2	BB30306	BEARING, TAPPED
6	1	1388716	NUT PLATE, LEAD SCREW	16	2	BB60062RS	BEARING,BALL,30MM B,2 SL
7	1	1389292	SHAFT, DRIVE, EXTENDED	17	2	MM9740K16	BELLOW, 4.25 ID,ZIPPER
8	1	1389293M	MOUNT, ROLLER BEARING	18	2	MM98409A003	RETAINING RING,INT,2.188B
9	1	1389296M	MOUNT, ROLLER BEARING	19	1	NNHM12X1.75	NUT,HEX,M12
10	1	1389297	BEARING THRUST DISC	20	1	SSSCM12X50	SCREW, M12 X 50

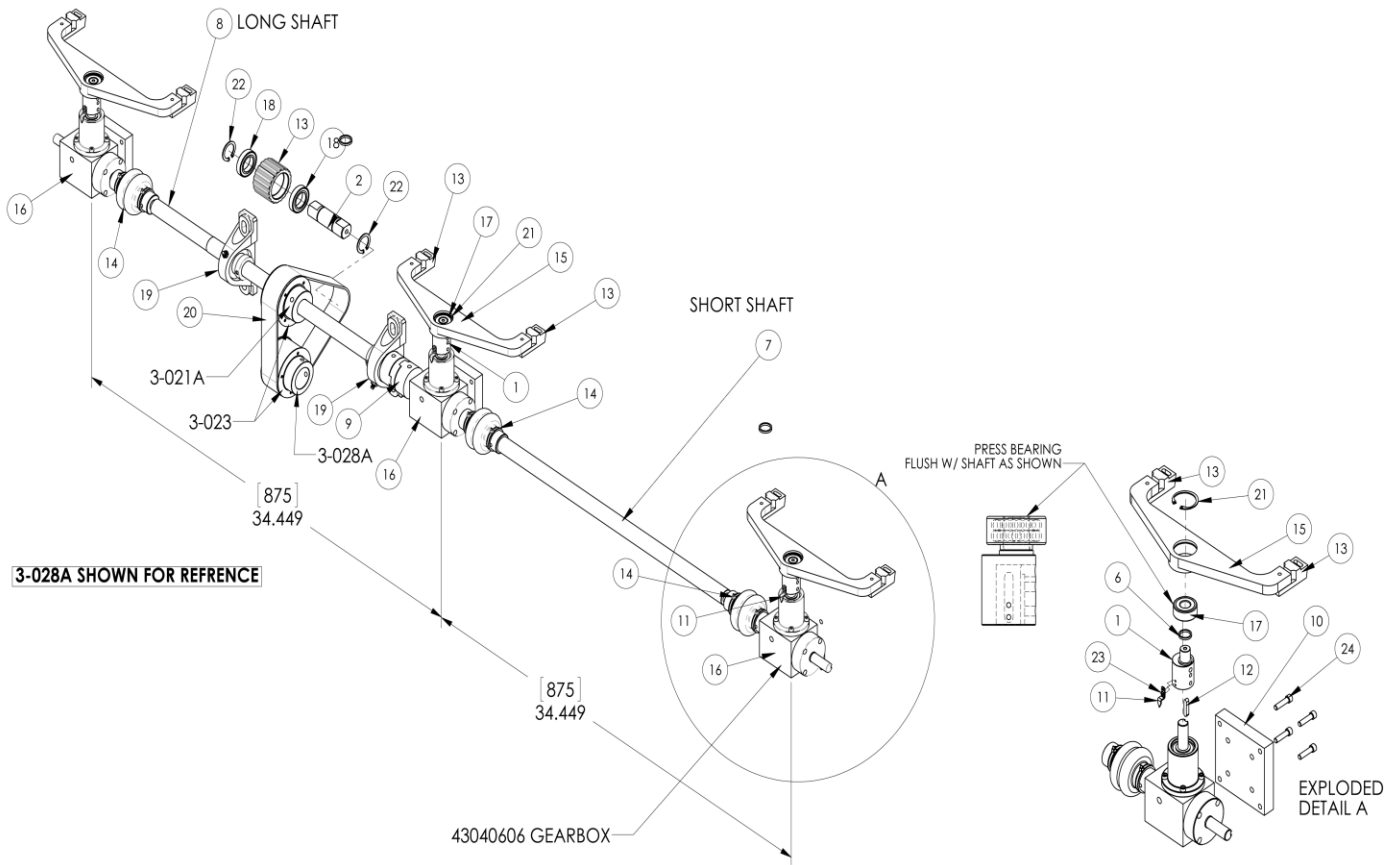

1389495 Retainer Drive Assembly

AAC Drawing Number 1389495 Rev 6

NO	QTY	PART #	DESCRIPTION	NO	QTY	PART #	DESCRIPTION
1	3	1-093	ECCENTRIC, RETAINER DRIVE	13	6	1392641	BLOCK, RETAINER
2	1	3-020	SHAFT, TAKE-UP, PULLEY	14	3	1392991	U-JOINT, RETAINER, ASM
3	1	3-021A	PULLEY, GEAR, 40MM WIDE	15	3	1393976	BOOMERANG, RETAINER
13	1	3-022	PULLEY, GEAR, 40MM WIDE	16	3	4.3E+07	GEARBOX, SPIRAL BEVEL
5	2	3-023	PLATE, SIDE, PULLEY	17	3	BB22022	BEARING, BALL, 15ID, 35OD
6	3	1386653	SPACER, BEARING	18	2	BB69052	BEARING, RADIAL, SEALED
7	1	1389381	SHAFT, SPREADER DRIVE, RT	19	2	BBNAP2	BEARING, PILLOWBLOCK
8	1	1389382	SHAFT, SPREADR DRIVE, LEFT	20	1	GG240L	BELT, GEAR, 3/8P, 1-1/2W
9	1	1389383	COUPLING, OFFSET, OLDHAM	21	3	MM984	E-RING, INT, 1-3/8 X .051
10	3	1389488	MOUNT, GEARBOX, RETAINER	22	2	MM985	RETAINING RING, 25MM EXT
11	3	1389711	POINTER, RETAINER	23	6	SSPSM3	SCREW, PAN HD SLOTTED
12	3	1389713	5MM X 5MM X 25MM KEY	24	12	SSSC050	1/4-28 X 1 SOC CAP

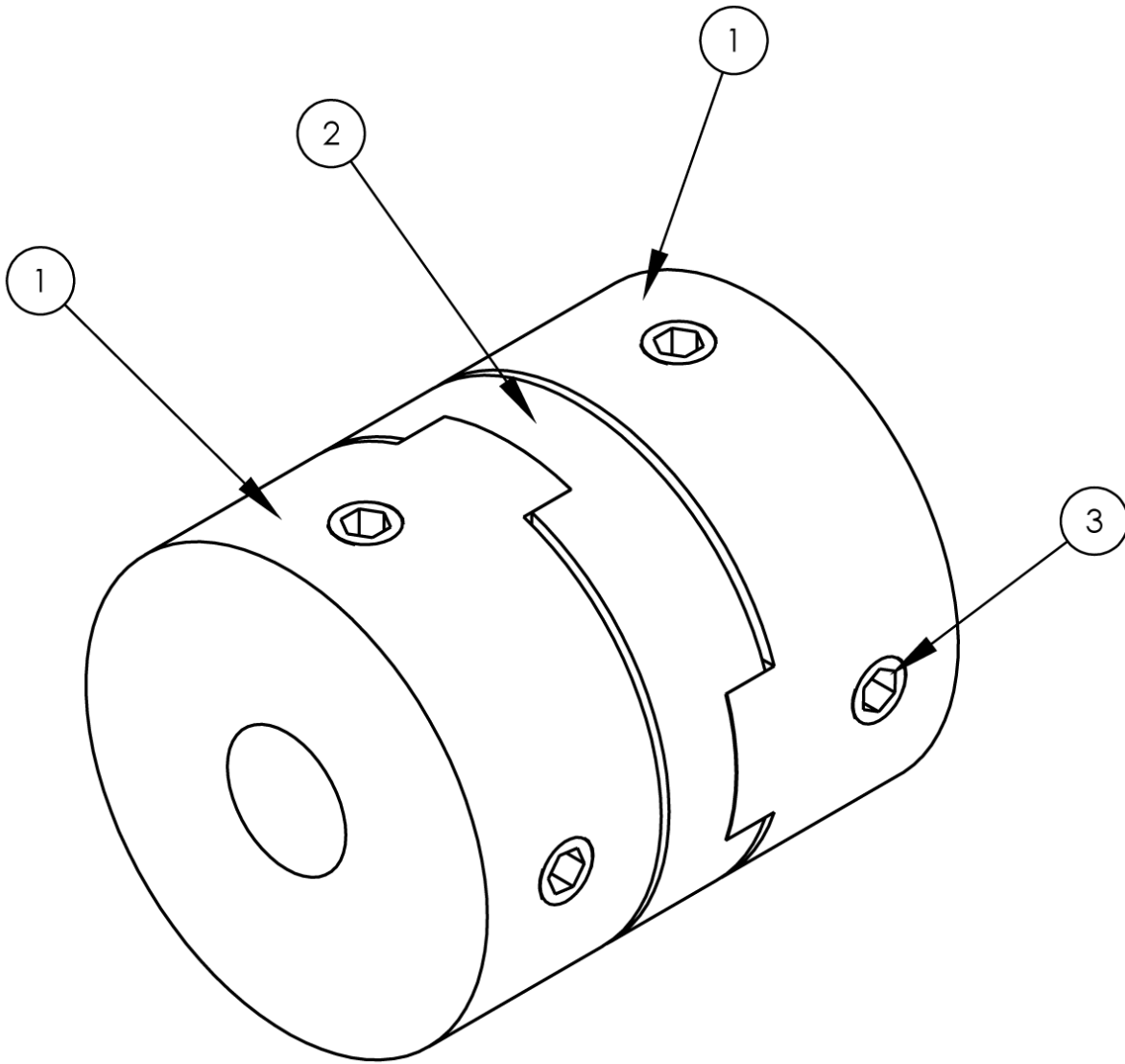

1389383 Oldham Offset Coupling

AAC Drawing Number 1389383 Rev 0

NO.	QTY	PART #	DESCRIPTION
1	2	1389402	COUPLING HALF
2	1	1389403	SPIDER FOR COUPLING
3	4	SSSM8X10	M8X10 SOC SET SCRW

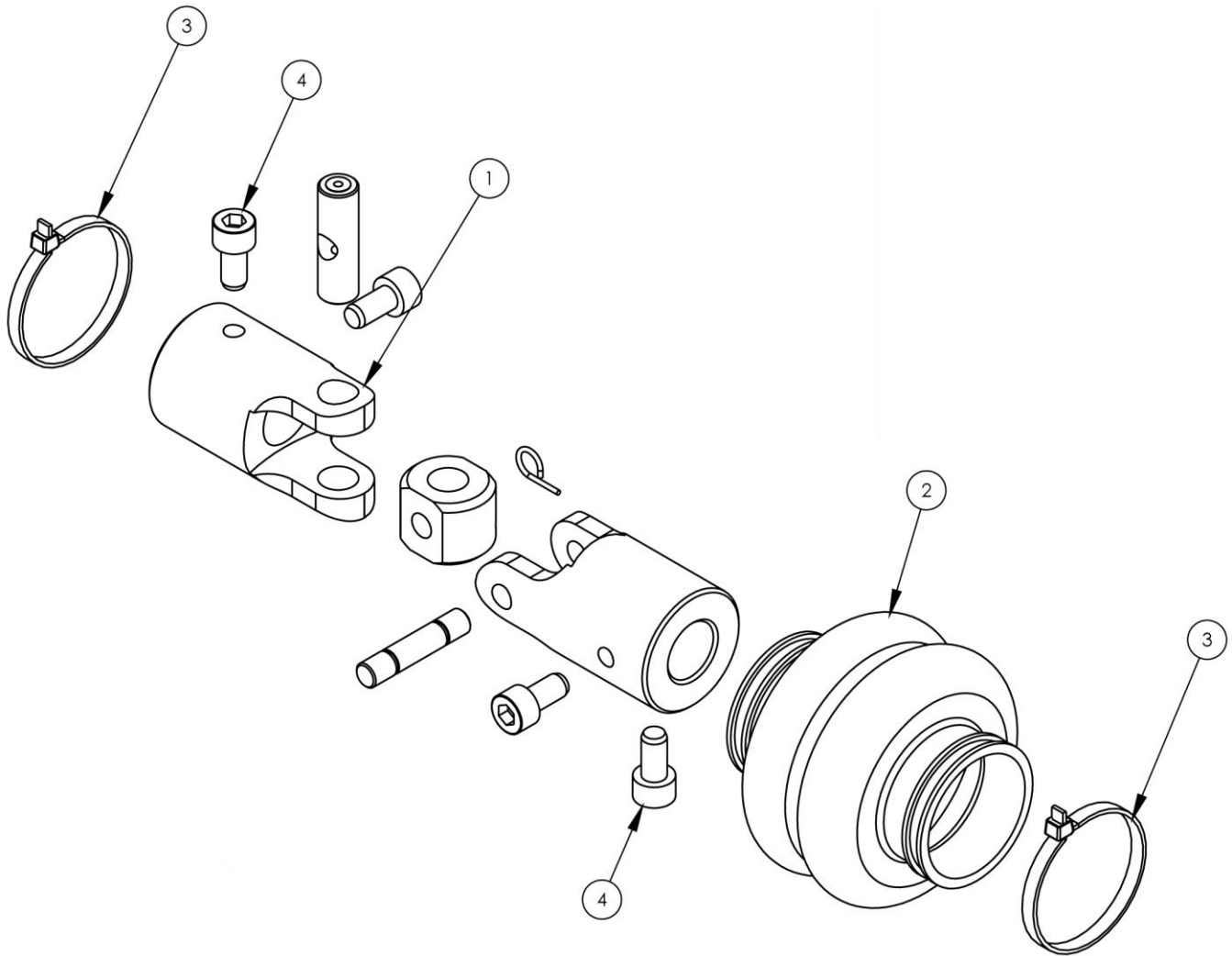

1392991 U-Joint, Retainer Assembly

AAC Drawing Number 1392991 Rev 1

NO.	QTY	PART #	DESCRIPTION
1	1	1392990	U-JOINT MOD
2	1	UJCJ6489K	BOOT, UNIVERSAL JOINT
3	2	EE6X750	TIE WRAP - Small.
4	4	SSSCM6X12	M6X12 SOC CAP SCREW

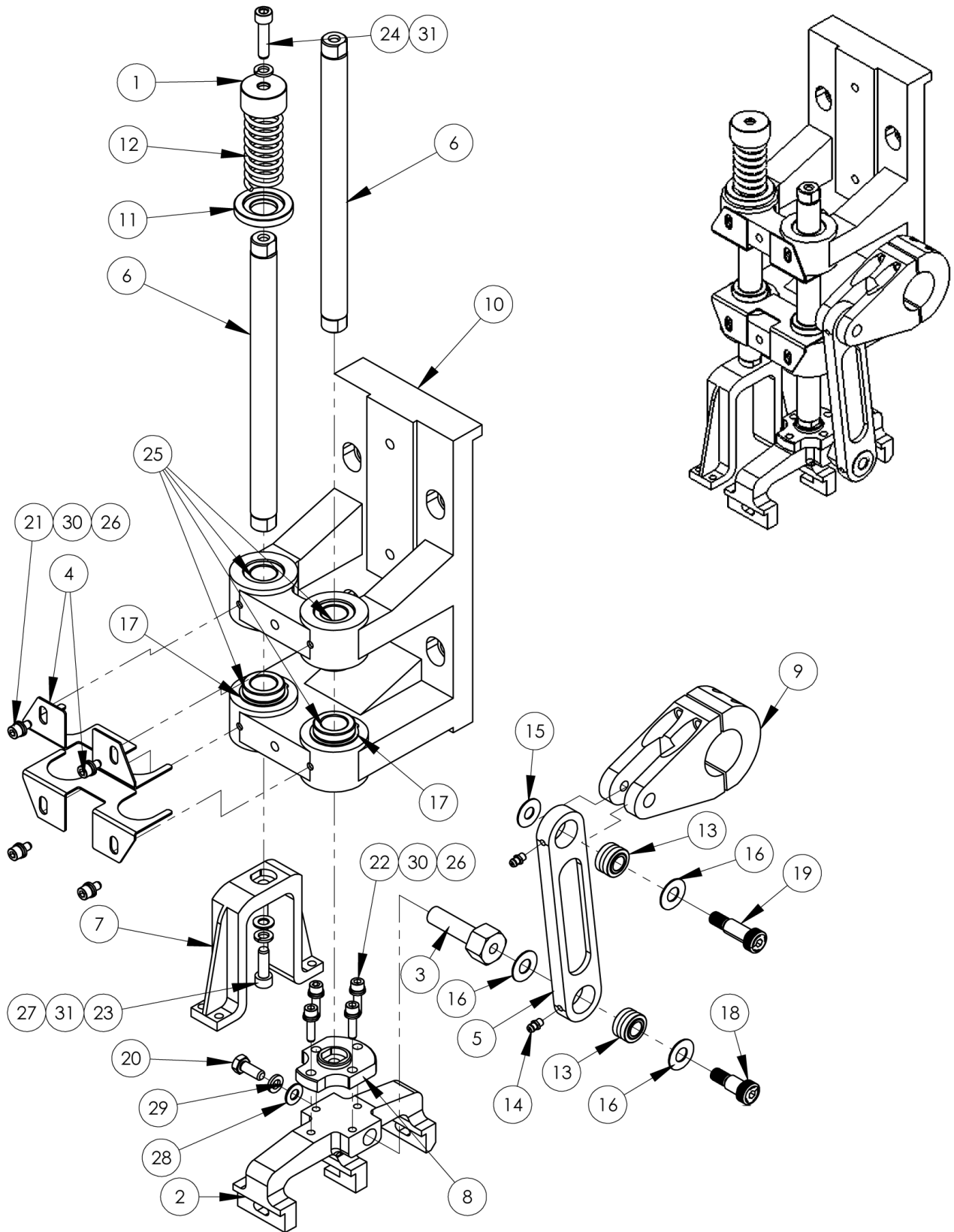

1393998 Right Needle and Presser Foot Drive Assembly

AAC Drawing Number 1393998 Rev 11

NO	QTY	PART #	DESCRIPTION
1	1	**1389016B	GUIDE, SPRING, PRESSER
2	1	1389539	NEEDLE BAR
3	1	1389640	DRIVE PIN, NEEDLE BAR
4	2	1393870	RETAINER, LINEAR
5	1	1393908	LINK,NEEDLE BAR DRIVE
6	2	1393973	NEEDLE/PRESSER BAR
7	1	1393974	BRACKET,PRESSER FOOT
8	1	1393979	PLATE,NEEDLE BAR
9	1	1393980	CRANK,NEEDLE BAR
10	1	2-002	NEEDLE BAR BEARING
11	1	5-007	GUIDE, SPRING, PRESSER
12	1	RRLC135M04	SPRING, COMP.
13	2	BBNA4901A2R	BEARING,NEEDLE,12MM
14	2	MM1105K71	GREASE FITTING, M6X1
15	1	MM5909K71	WASHER,THRUST,10MM ID
16	3	MM5909K72	WASHER,THRUST,12MM ID
17	4	MM98541A139	RETAINING RING,32MM
18	1	SSASM12M16	SCREW,ALLEN SHOULDER
19	1	SSASM12M25	SCREW,ALLEN SHOULDER
20	1	SSHCM8X20	SCREW,HEX CAP
21	4	SSSCM6X12	M6X12 SOC CAP SCREW
22	4	SSSCM6X25	M6X25 SOC CAP SCREW
23	1	SSSCM8X25	SCREW,SOC CAP,M8X25
24	1	SSSCM8X35	SCREW,SOC CAP,M8X35
25	4	UUFM20	BEARING,AL-FRELON
26	8	WWFM6	WASHER, FLAT, M6, SAE
27	1	WWFM8	WASHER, FLAT, M8 I.D.
28	1	WWFS5/16	WASHER,FLAT,SAE,5/16
29	1	WWL5/16	WASHER,LOCK, 5/16
30	8	WWLM6	WASHER,LOCK,M6
31	2	WWLM8	M8 LOCK WASHER

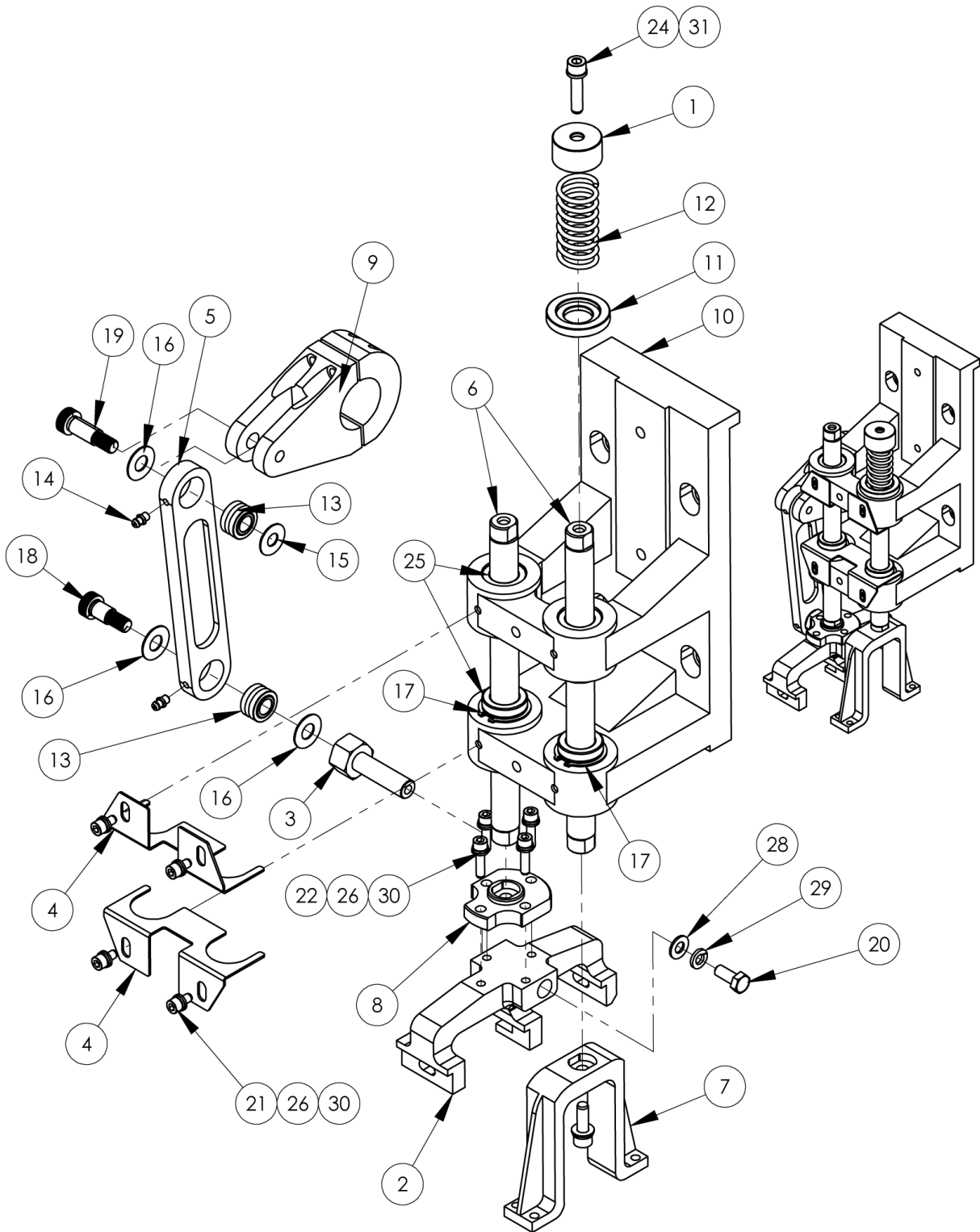

1393999 Left Needle and Presser Foot Drive Assembly

AAC Drawing Number 1393999 Rev 11

NO	QTY	PART #	DESCRIPTION
1	1	**1389016B	GUIDE, SPRING, PRESSER FT
2	1	1389539	NEEDLE BAR CONNECTOR
3	1	1389640	DRIVE PIN, NEEDLE BAR
4	2	1393870	RETAINER, LINEAR BEARING
5	1	1393908	LINK,NEEDLE BAR DRIVE
6	2	1393973	NEEDLE/PRESSER BAR ASSY
7	1	1393974	BRACKET,PRESSER FOOT
8	1	1393979	PLATE,NEEDLE BAR ATTACH
9	1	1393980	CRANK,NEEDLE BAR DRIVE
10	1	2-002	NEEDLE BAR BEARING BLOCK
11	1	5-007	GUIDE, SPRING, PRESSER FT
12	1	RRLC135M04M	SPRING, COMP. 135X1.09X3
13	2	BBNA4901A2RSR	BEARING,NEEDLE,12MM ID
14	2	MM1105K71	GREASE FITTING, M6X1
15	1	MM5909K71	WASHER,THRUST,10MM ID
16	3	MM5909K72	WASHER,THRUST,12MM ID
17	4	MM98541A139	RETAINING RING,32MM EXT
18	1	SSASM12M16	SCREW,ALLEN SHOULDER
19	1	SSASM12M25	SCREW,ALLEN SHOULDER
20	1	SSHCM8X20	SCREW,HEX CAP
21	4	SSSCM6X12	M6X12 SOC CAP SCREW
22	4	SSSCM6X25	M6X25 SOC CAP SCREW
23	1	SSSCM8X25	SCREW,SOC CAP,M8X25
24	1	SSSCM8X35	SCREW,SOC CAP,M8X35
25	4	UUFM20	BEARING,AL-FRELON 20MM ID
26	8	WWFM6	WASHER, FLAT, M6, SAE
27	1	WWFM8	WASHER, FLAT, M8 I.D.
28	1	WWFS5/16	WASHER,FLAT,SAE,5/16
29	1	WWL5/16	WASHER,LOCK, 5/16
30	8	WWLM6	WASHER,LOCK,M6
31	2	WWLM8	M8 LOCK WASHER



1389815 Main Drive Shaft Assembly

AAC Drawing Number 1389815 Rev 2

NO.	QTY	PART#	DESCRIPTION	NO.	QTY	PART#	DESCRIPTION
1	7	1-010A	SHAFT SUPPORT, BEARING	17	2	1388774	KEY,8MM X 10MM X 34MM
2	1	1-012A	MAIN SHAFT COUPLING	18	1	1392509	PULLEY, GEAR, 38MM WIDE
3	2	1-017	ROD END, PRESSER FOOT	19	1	1392548	INDICATOR
4	14	1-051B	COVER, BEARING	20	1	1392549	HANDWHEEL ASSY,
5	4	2-060	NEEDLE BAR ECCENTRICS	21	1	A9C39M100856	KEY, SHAFT
6	4	2-061	NDL BAR ECCENTRIC PLATE	22	7	BB1208K	BEARING, TAPPED BORE
7	4	2-062	ECCENTRIC INSERT,LARGE	23	4	BB60132RS	BEARING, RADIAL,SEALED
8	4	2-063A	ECCENTRIC, LINKAGE	24	4	BB60162RS	BEARING, RADIAL, SEALED
9	4	2-064B	ECCENTRIC INSERT,SMALL	25	2	BB62022RS	BEARING, RADIAL, SEALED
10	4	2-065	CAP, LOOPER ECENTRIC	26	7	BBH208	SLEEVE, ADAPTER
11	2	3-023	PLATE, SIDE, PULLEY	27	2	BBUKFL208	BEARING, FLANGE UKFL
12	1	3-028A	PULLEY, GEAR, 40MM WIDE	28	2	MMH0137	SNAP RING,INTERNAL
13	1	4-007-MA	SHAFT, L NDL BAR DRIVE,D	29	4	MMN1302375	RING,RET,BLVD,INT,3.75"
14	1	4-008-M	SHAFT,RIGHT NDL BAR	30	4	MMN1302475	RING,RET,BLVD,INT,4.75"
15	1	5-025	TARGET, PROX	31	2	SSBCM5X8	M5 X 8MM BUT HEAD
16	2	5-032	PITMAN ROD, 16MM X 320	32	2	WWL5/16	5/16 LW

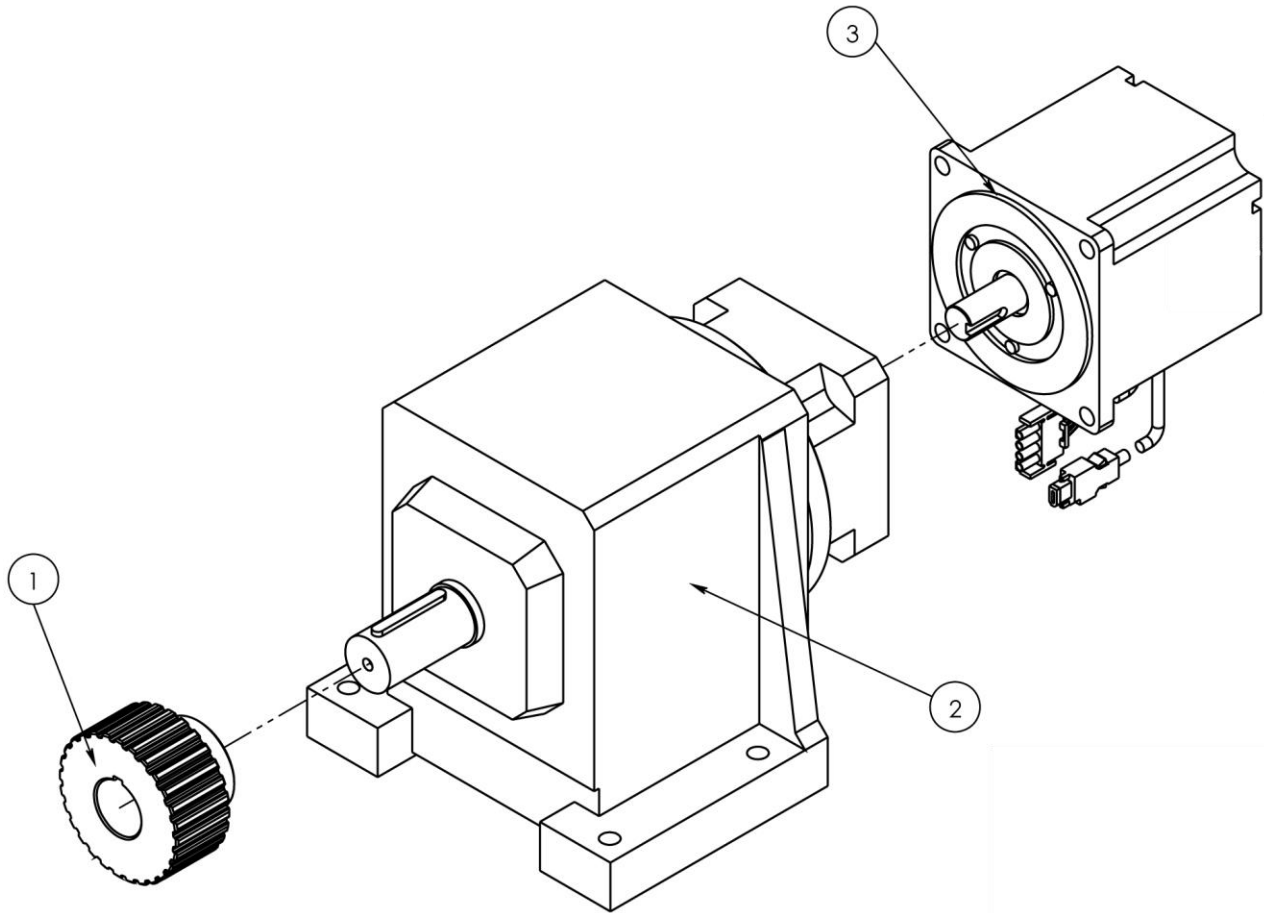

1392070 Roll Servo Drive Assembly

AAC Drawing Number 1392070 Rev 1

NO.	QTY	PART #	DESCRIPTION
1	1	1392809	PULLEY, GEAR, 38MM WIDE
2	1	C302N0410MT20	GEARBOX, CONC. HELICAL
3	1	SGMPH15AAE41D	MOTOR, SERVO, 1.5KW

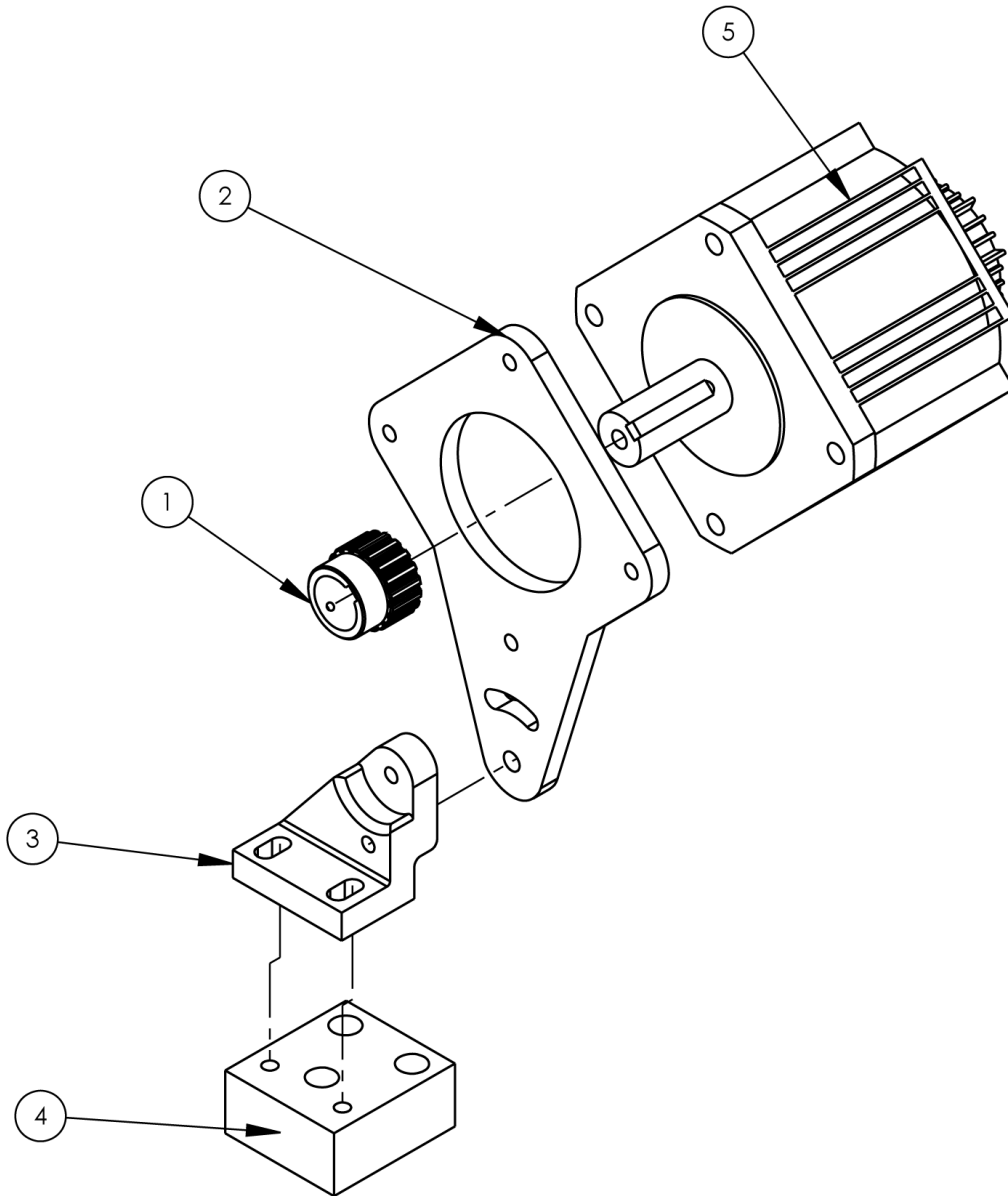

1392071 Carriage Servo Drive Assembly

AAC Drawing Number 1392071 Rev 0

NO.	QTY	PART #	DESCRIPTION
1	1	1-034	PULLEY, TIMING, 18T
2	1	2-033-M	MOUNT, MOTOR
3	1	2-046	BRACKET, MOTOR
4	1	6-010A	SPACER, MOTOR MOUNT
5	1	SGMGH30ACA61	MOTOR, SERVO 3.0KW

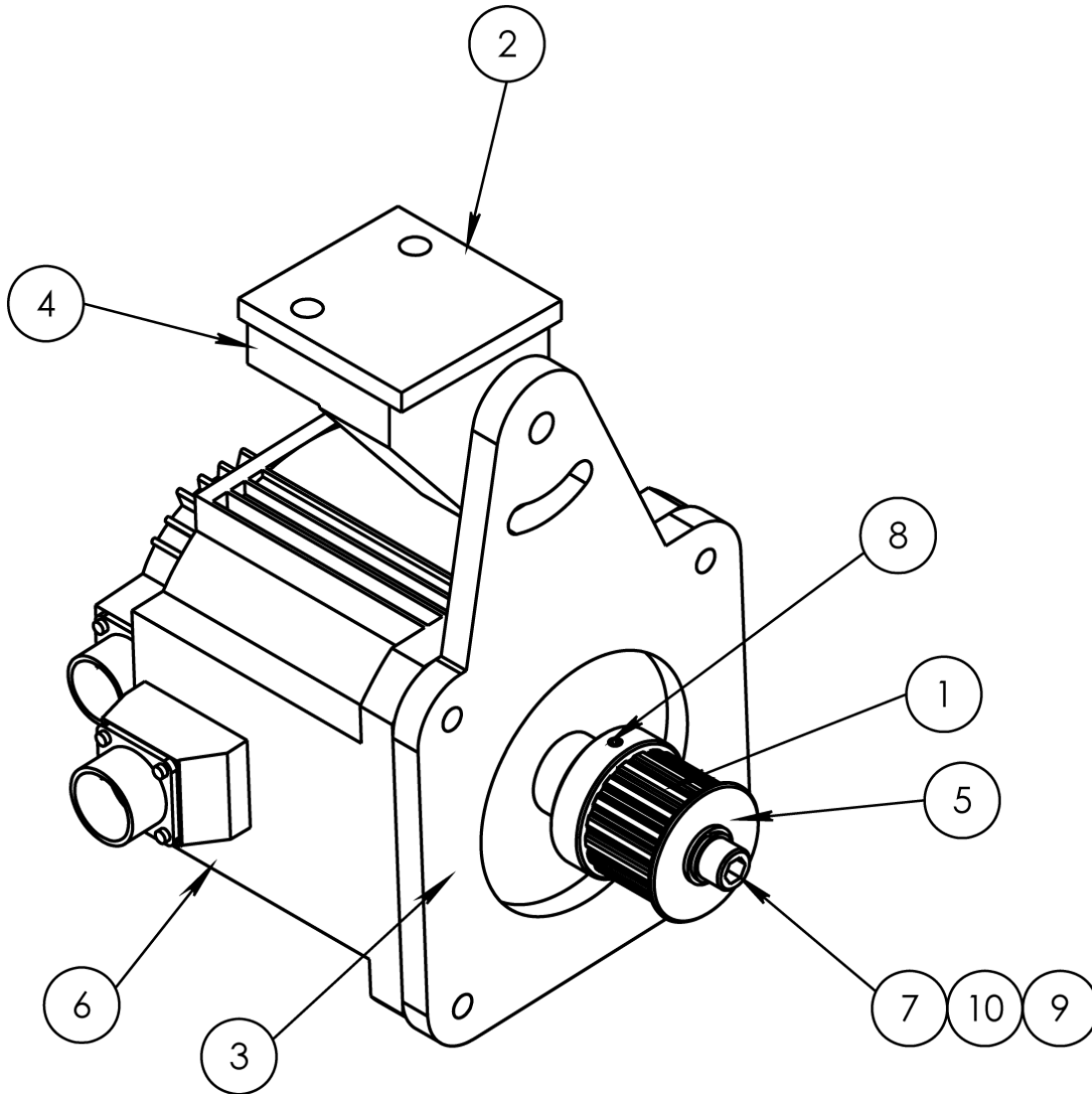

1392082 Needle Bar Drive Assembly

AAC Drawing Number 1392082 Rev 4

NO.	QTY	PART #	DESCRIPTION
1	1	1389827	PULLEY, GEAR, L 38MM WIDE
2	1	1392261	SPACER, MOTOR, BASE
3	1	1392499	MOUNT, MOTOR, BOTTOM
4	1	1392654	MOUNT, MOTOR, BASE
5	1	1392741	WASHER, PULLEY
6	1	SGMGH30ACA61	MOTOR, SERVO 3.0KW
7	1	SSSCM12X30	SCREW, SOC CAP, M12 X 30
8	2	SSSSM6X10	M6 SET SCREW, 10MM L
9	1	WWFM12	WASHER, FLAT, M12 I.D.
10	1	WWLM12	M12 LOCK WASHER

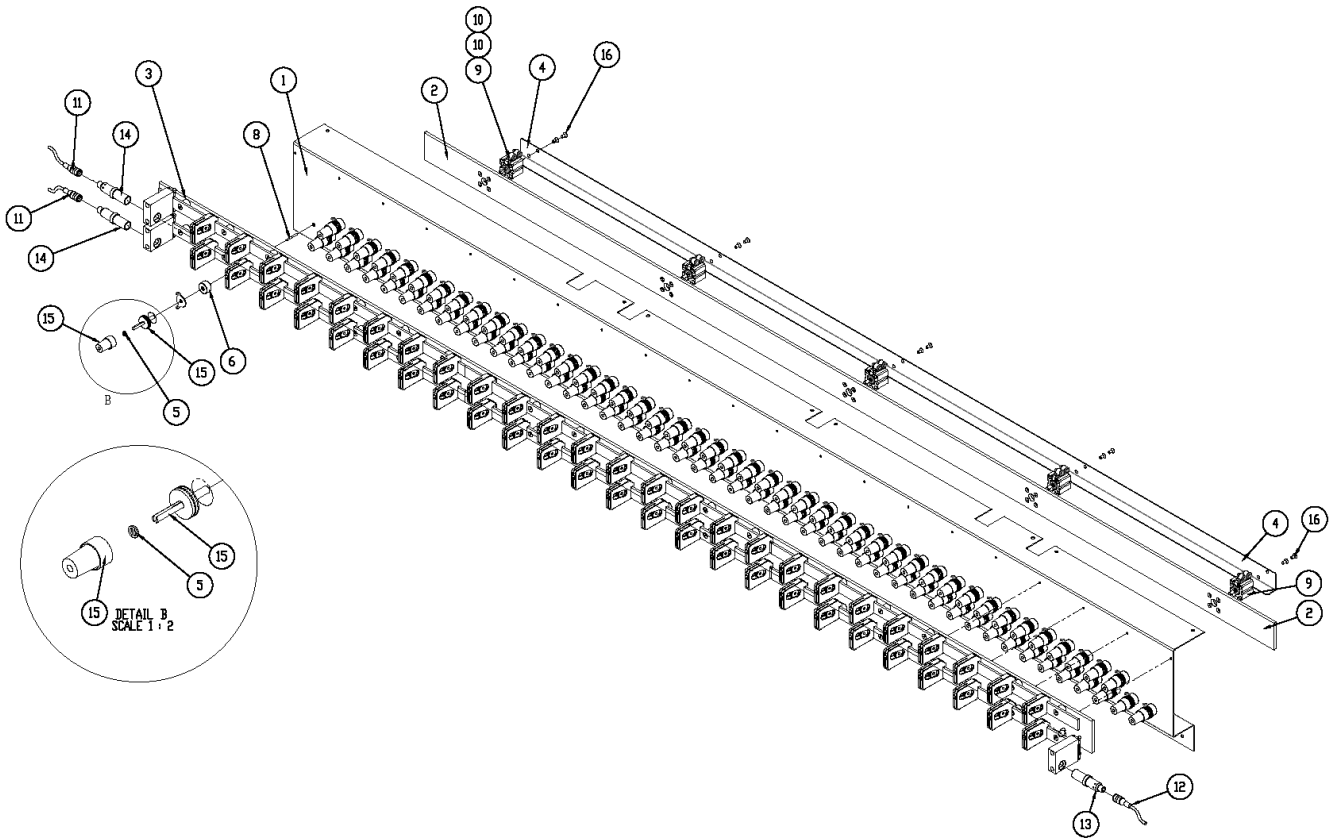

1392125 Rear Thread Tension Assembly

AAC Drawing Number 1392125 Rev 11

NO.	QTY	PART#	DESCRIPTION	NO.	QTY	PART#	DESCRIPTION
1	1	5-047C-M	MOUNT, MOD. REAR THRD	9	5	AACSDA20X10B	COMPACT,CYLINDER,20MM
2	1	5-059	PLATE,TENSION RELEASE	10	10	AAQME-4-10	ELBOW,QUICK MALE
3	1	1389271	THREAD BREAK DETECTOR	11	2	FFRK44T-4	CABLE,EYE,12',NO END
4	1	1389455	PLATE,TENSION RELEASE	12	1	FFRK44T-6	CABLE,EYE,19',NO END
5	*91	1389915	WASHER, THREAD TENS	13	1	FFS18SN6RQ	EYE,OPPOSED,RCVR,NPN,IR
6	91	1392126	SPACER, THREAD TENSION	14	2	FFS186EQ	EYE,OPPOSED,XMIT,IR LED,
7	AR	1392557	GUIDE, THREAD TENSIONER	15	91	SCT1392L	TENSION ASSY,1392 LOOPER
8	91	1392988	PIN, TENSION OPENER	16	11	SSFCM5X10	SCREW,FLAT ALLEN CAP

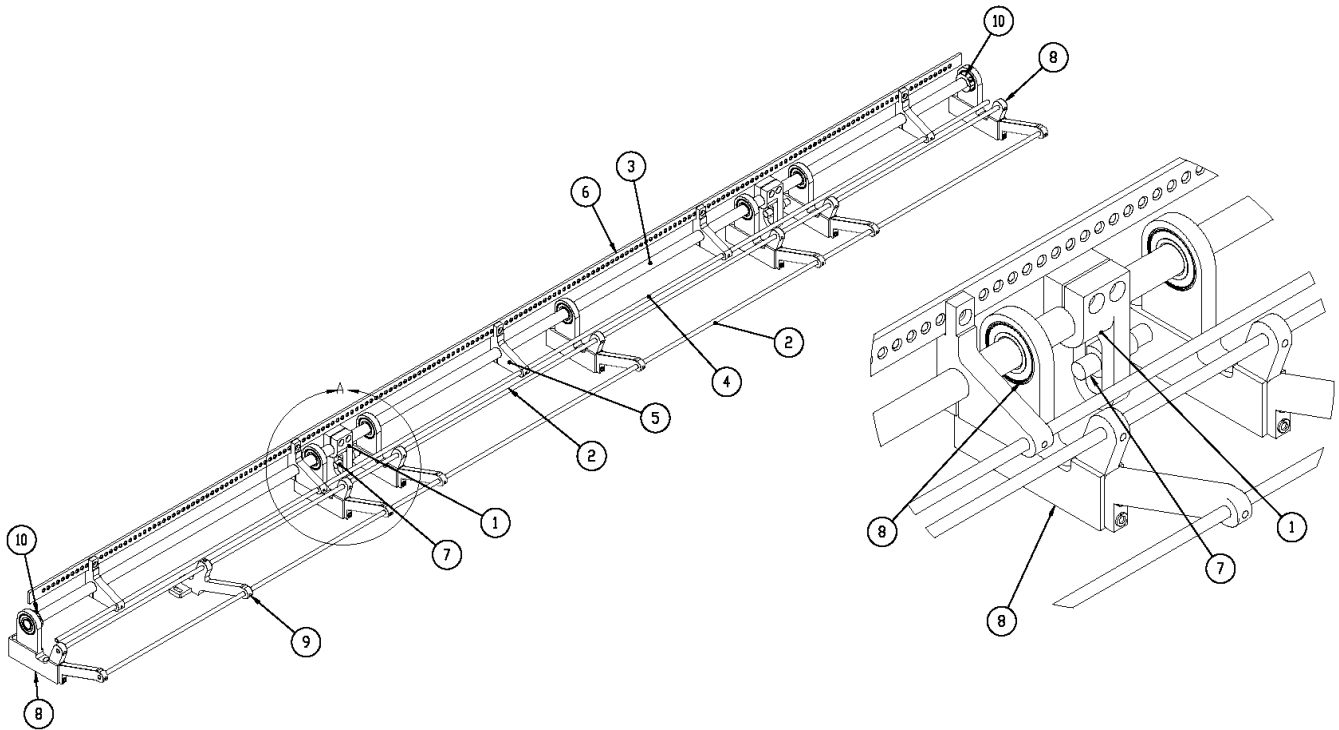

1392196 Take-up Looper Assembly

AAC Drawing Number 1392196 Rev 3

NO.	QTY	PART#	DESCRIPTION
1	2	2-081	DRIVE ARM, REAR BTRFLY
2	2	4-051	GUIDE, THREAD ROD
3	1	4-052	SHAFT, REAR TAKE-UP
4	1	4-053	ROD, REAR TAKE-UP
5	5	4-083	TAKE-UP, THREAD ROCKER
6	1	4-084A	GUIDES, THREAD
7	2	5-033	SHAFT, RODEND, REAR BTRFLY
8	7	1392304	BUTTERFLY, BEARING ASSY
9	1	1392983	ROD SUPPORT, REAR THREAD
10	2	CCCLM20F	CLAMP COLLAR- M20

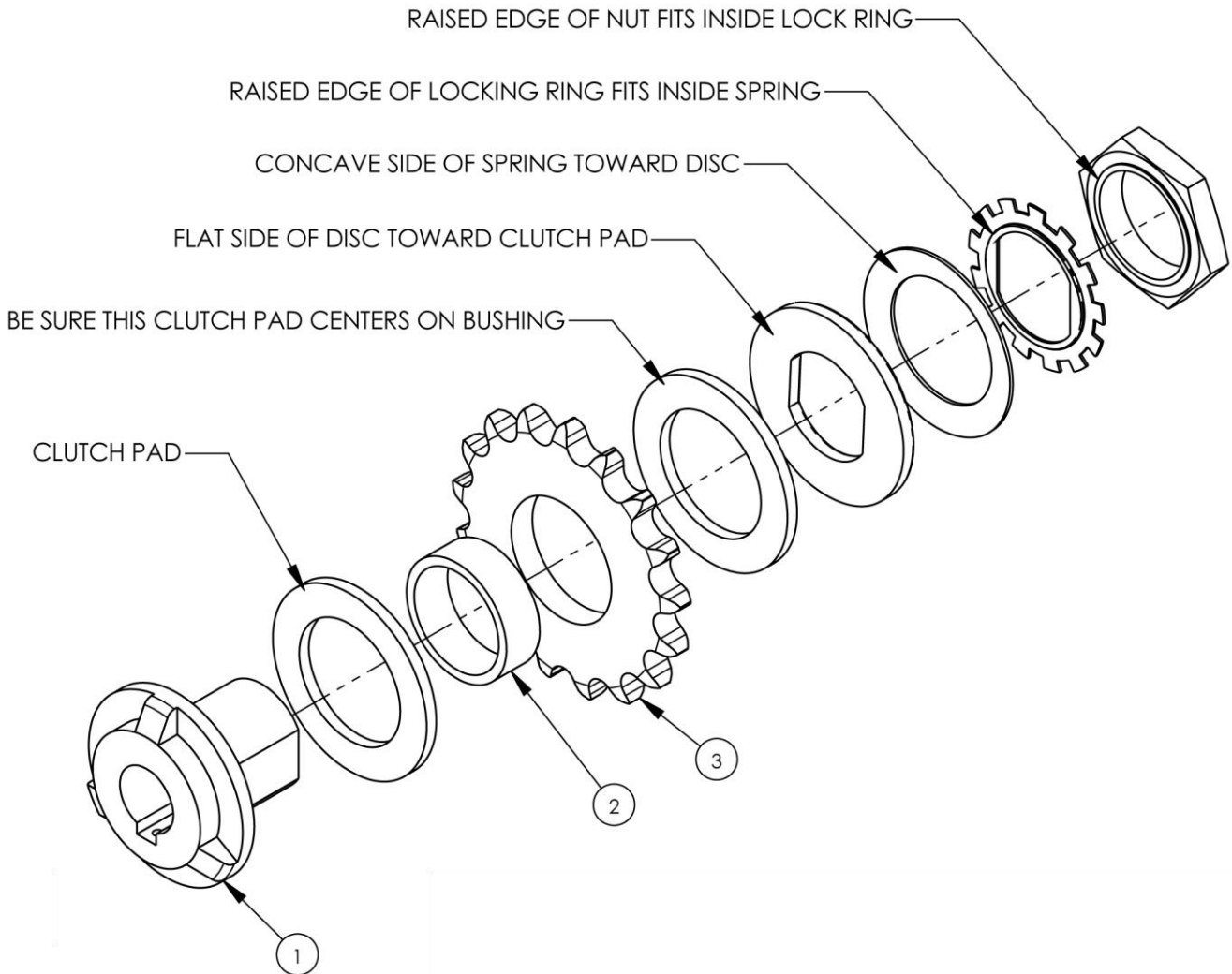

1389575 Torque Limit Assembly

AAC Drawing Number 1389575 Rev 1

NO.	QTY	PART #	DESCRIPTION
1	1	1389569	HUB, MODIFIED, 22MM B
2	1	BB250AX_540	BUSHING, .54L, FOR TORQUE L
3	1	MM250AG517	SPROCKET, TORQUE LIMITER

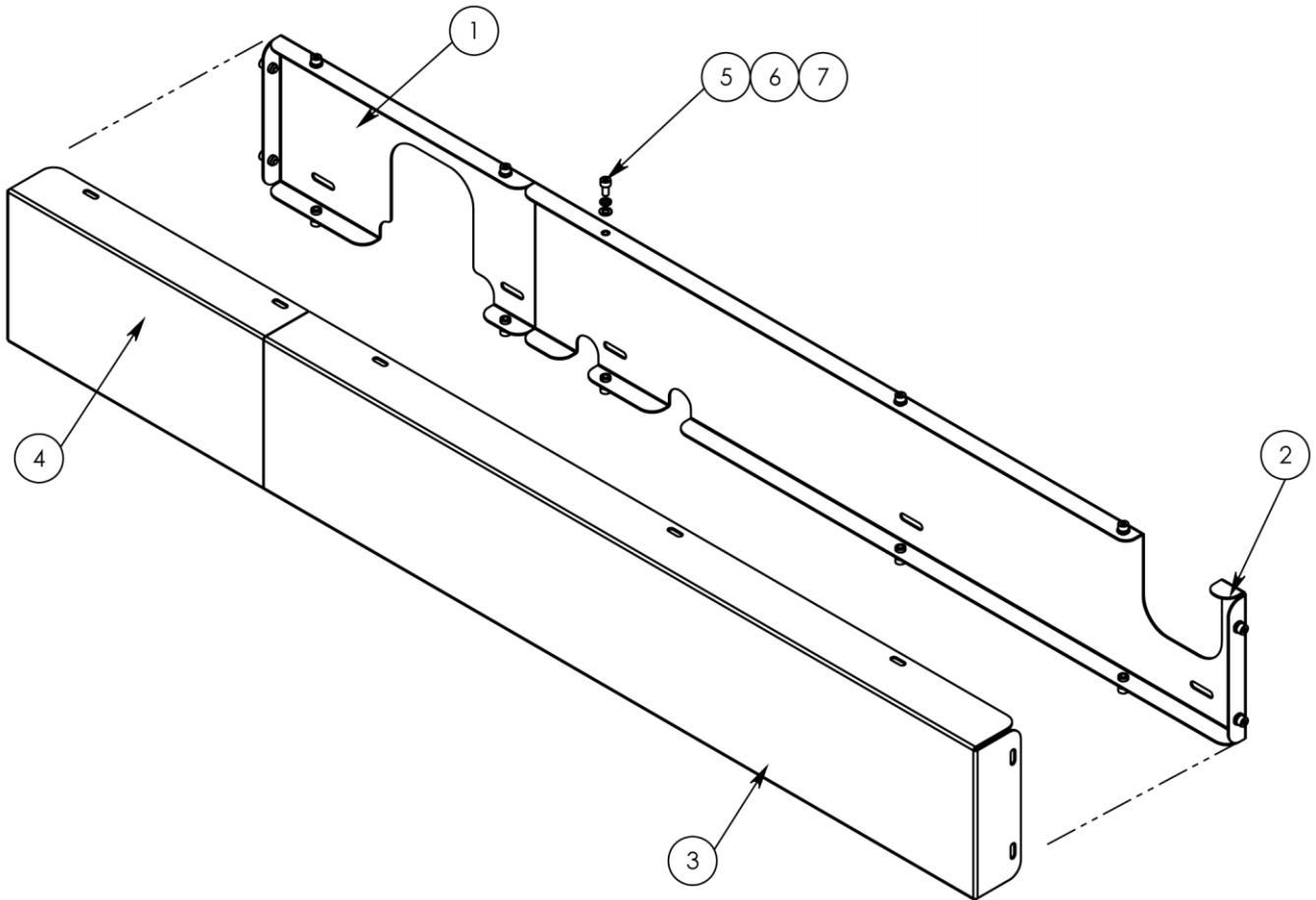

1392230 Guard Assembly

AAC Drawing Number 1392230 Rev 1

NO.	QTY	PART #	DESCRIPTION
1	1	1392466	GUARD, BASE FIXTURE,S
2	1	1392561	GUARD,BASE ASSM,L
3	1	1392562	GUARD, CLOSURE,L
4	1	1392564	GUARD, CLOSURE,S
5	14	SSSCM5X10	SCREW,SOC CAP,M5-0.8 X 10
6	14	WWFM5	WASHER, FLAT, M5 I.D.
7	14	WWLM5	M5 LOCK WASHER

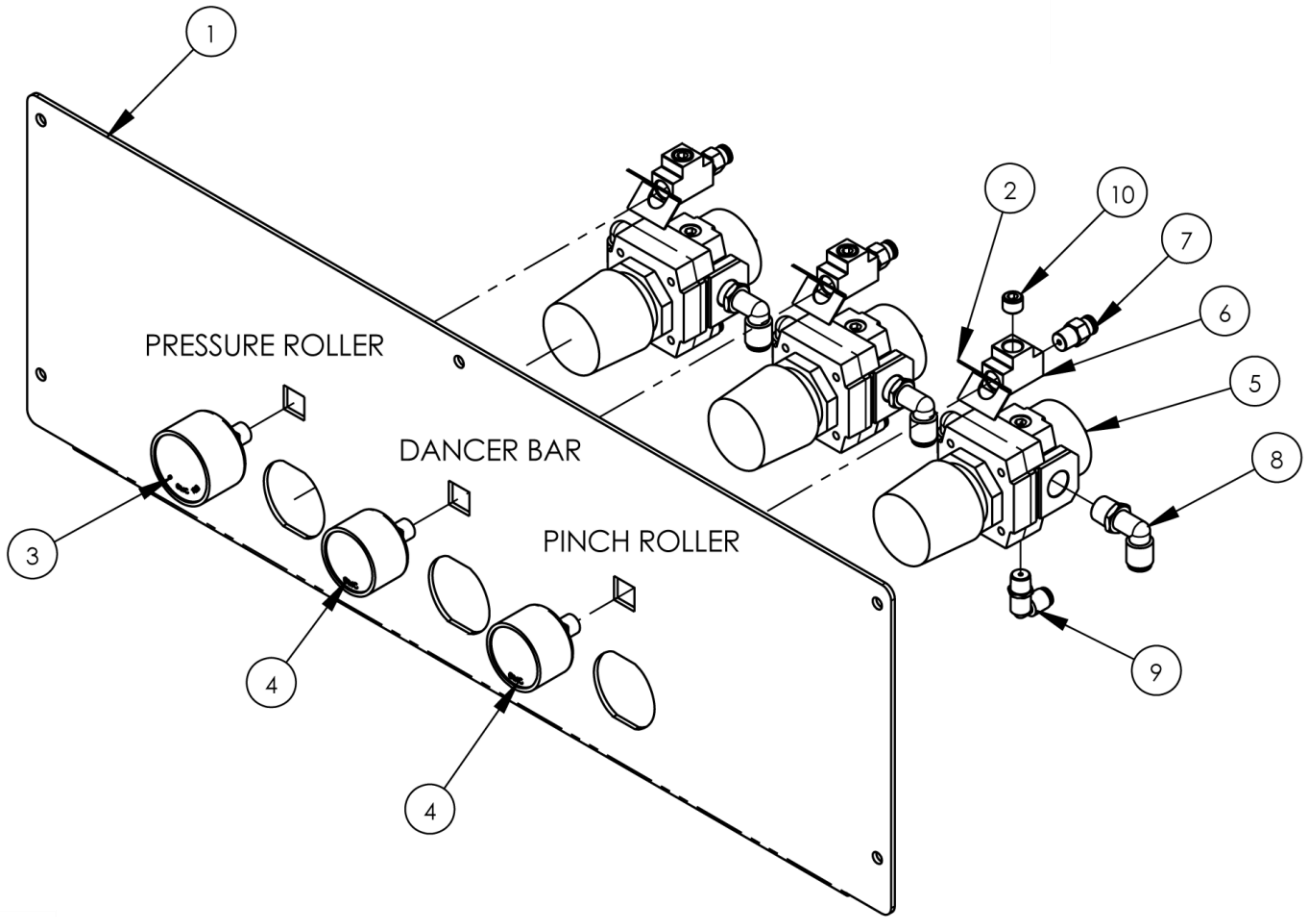

1389183 Regulator Assembly

AAC Drawing Number 1389183 Rev 1

NO.	QTY	PART #	DESCRIPTION
1	1	1389182	PLATE,REGULATOR MTG
2	3	31103701	BRKT,PRESSURE GAUGE
3	1	AA198-5031	0-160PSI AIR GAGE 1/8NPT
4	2	AA198-5032	0-60PSI AIR GAGE 1/8NPT
5	3	AA198-RP3	REGULATOR,Precision AIR
6	3	AAF10289	T-FITTING 1/4" NPT
7	3	AAQMC-5-8	QU. MALE CONN 5/32X1/8
8	6	AAQME-4-4	ELBOW, MALE,1/4X1/4NPT
9	3	AAQME-5-8	QUICK MALE ELBOW
10	3	MM4554K11	PLUG, 1/8" PIPE

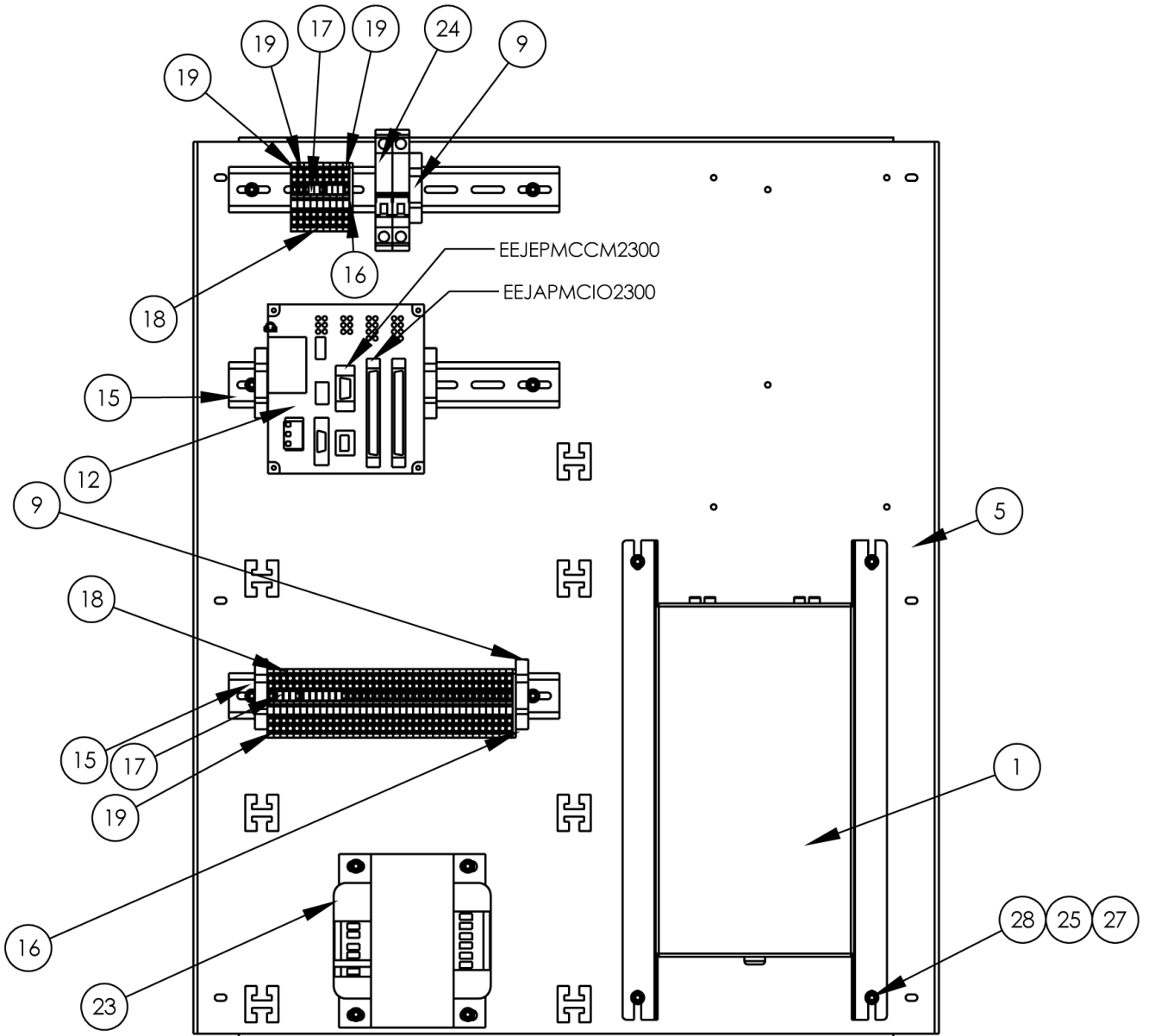

1392366 Front Side Backplane Assembly

AAC Drawing Number 1392366 Rev 5

NO.	QTY	PART #	DESCRIPTION
1	1	1392515	REGEN RESISTOR ASSY
2	1	1392663	CABLE ASSY,MP2300 I/O
3	1	1392664	CABLE ASSY,QUILTER I/O
4	1	1392665	CABLE ASSY,FLUOR LIGHT
5	1	1392684	PANEL,FRONT BACKPLANE
6	1	1392688	CABLE ASSY,CARR LIMIT
7	1	1392691	CABLE ASSY,SSR
8	11'	EE16-3C2406	CABLE,3 COND,16AWG,300V
9	5	EECLIPFIX	ANCHOR,DIN RAIL
10	1	EEJAPMCIO2300	I/O CARD,16PT,SINK OUT
11	1	EEJPMCCM2300	COMM CARD,RS232/ETHERNET
12	1	EEJPMCMP2300	CONTROLLER, MOTION
13	1	EEJPMCOP300	RAIL CLIP,MP2300
14	1	EEJPMCOP2300	SLOT COVER
15	30"	EETS35X7.5A	DIN RAIL-AMERICAN
16	2	FF280-308	TERMBLK ENDPLATE,WAGO,280
17	14	FF280-402	JUMPER,WAGO,TOP,SNGL
18	42	FF280-901	TERMBLK,WAGO,TOP,SNGL,GRY
19	4	FF280-907	TERMBLK,WAGO,TOP,SNGL,GRN
20	1	FF3077-2	WIRE, 16 AWG BLACK
21	1	FF3077-3	WIRE,STR,#16,PVC,RED
22	1	FF3077-28	WIRE, 16 AWG GRN/YEL
23	1	FFMPI-650-230	TRANSFORMER, 5.6A
24	1	FFQL213DMKM10	CIRCUIT BREAKER,10A,2P
25	14	SSSCM5X16	SCREW,SOC CAP,M5-0.8 X 16
26	1	TTBB5263	TERMINAL,.25 FULLY INSUL
27	14	WWFM5	WASHER, FLAT, M5 I.D.
28	14	WWL10	WASHER,LOCK,#10

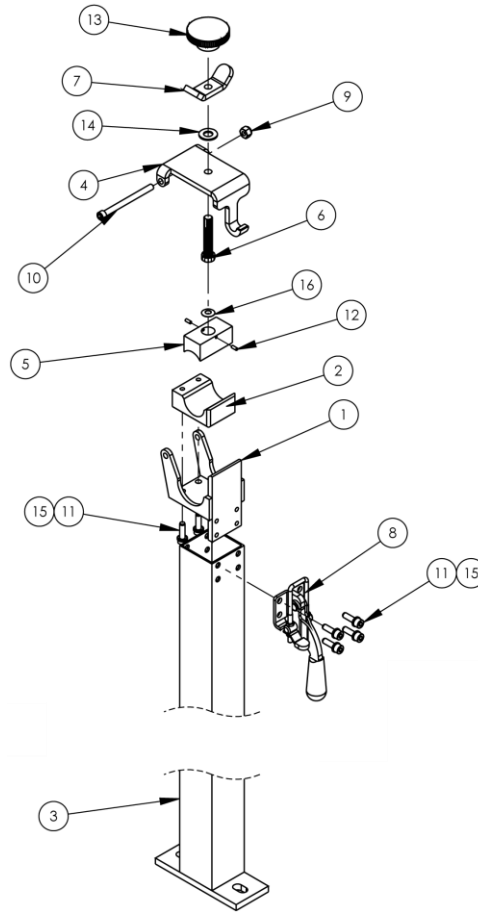

1392545 Material Tension Rack

AAC Drawing Number 1392545 Rev 7

NO.	QTY	PART #	DESCRIPTION
1	1	1389408	ROD SUPPORT/BRAKE ASSY
2	1	1389410	BLOCK, BRAKE, BOTTOM
3	1	1392453	LEG WELDMT, MATL RACK
4	1	1392542	PLATE, CAP, FRICTION BRAKE,
5	1	1392543	BLOCK, DELRIN, S
6	1	1393802	3/8-24 X 2 HEX HEAD FULL THD
7	1	1393803	NUT, WING, 3/8-24
8	1	MM331	CLAMP, PULL LATCH
9	1	NNE1/4-20	NUT, ELASTIC LOCK, 1/4-20
10	1	SSSC01192	1/4-20 X 3 SOC CAP
11	6	SSSCM6X20	SCREW, SOCKET CAP
12	2	SSSSM3X8	M3 SET SCREW, 8MM L
13	1	TTK32315	KNOB, 1-7/8OD, 3/8B, BLACK
14	1	WWFS3/8	WASHER, FLAT, SAE, 3/8
15	6	WWLM6	M6 LOCK WASHER
16	1	WWS307-1	WASHER, SPRING, BELVEL

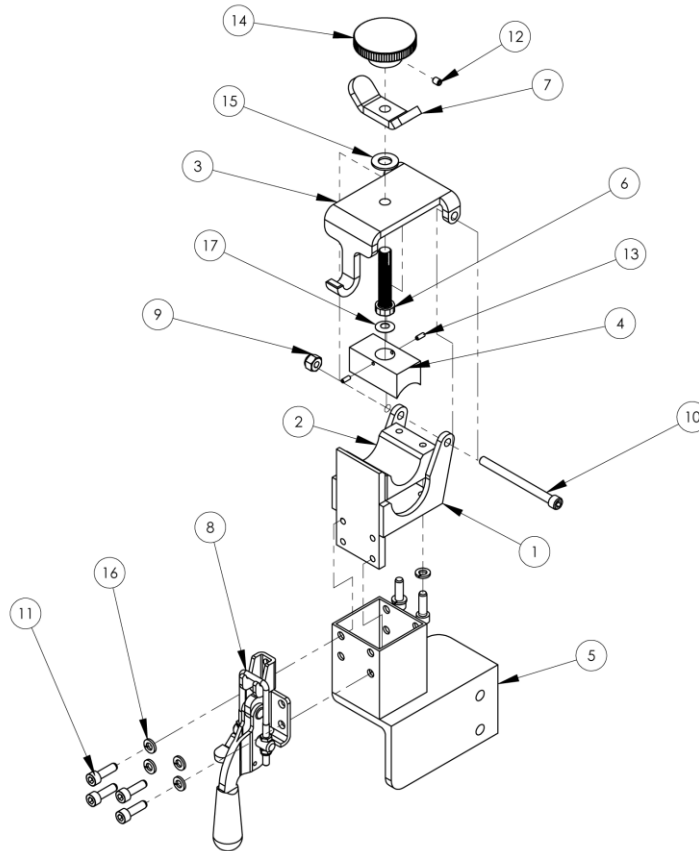

1392972 LH Small Tension Clamp Assembly

AAC Drawing Number 1392972 Rev 8

NO	QTY	PART #	DESCRIPTION
1	1	1389408	ROD SUPPORT/BRAKE ASSY
2	1	1389410	BLOCK, BRAKE, BOTTOM
3	1	1392542	PLATE, CAP, FRICTION BRAKE,
4	1	1392543	BLOCK, DELRIN, S
5	1	1392964	MATERIAL BRKT
6	1	1393802	3/8-24 X 2 HEX HEAD FULL
7	1	1393803	NUT, WING, 3/8-24
8	1	MM331	CLAMP, PULL ACTION, 700LB
9	1	NNE1/4-20	NUT, ELASTIC LOCK, 1/4-20
10	1	SSSC01192	1/4-20 X 3 SOC CAP
11	6	SSSCM6X20	M6 X 20, SOC CAP
12	1	SSSS98016	SCREW, SKT SET, FLAT POINT
13	2	SSSSM3X8	M3 SET SCREW, 8MM L
14	1	TKK32315	KNOB, 1-7/8OD, 3/8B, BLACK
15	1	WWFS3/8	WASHER, FLAT, SAE, 3/8
16	6	WWLM6	WASHER, LOCK, M6
17	1	WWS307-1	WASHER, SPRING, BELVEL

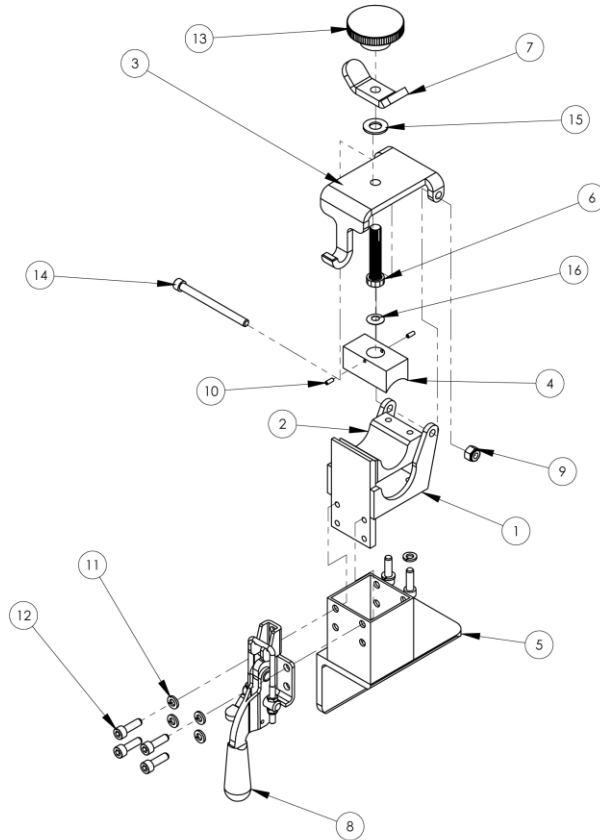

1392973 RH Small Tension Clamp Assembly

AAC Drawing Number 1392973 Rev 8

NO.	QTY	PART #	DESCRIPTION
1	1	1389408	ROD SUPPORT/BRAKE ASSY
2	1	1389410	BLOCK, BRAKE, BOTTOM
3	1	1392542	PLATE, CAP, FRICTION BRAKE,
4	1	1392543	BLOCK, DELRIN, S
5	1	1392966	MATERIAL BRKT
6	1	1393802	3/8-24 X 2 HEX HEAD FULL THD
7	1	1393803	NUT, WING, 3/8-24
8	1	MM331	CLAMP, PULL LATCH
9	1	NNE1/4-20	NUT, ELASTIC LOCK, 1/4-20
10	2	SSSSM3X8	M3 SET SCREW, 8MM L
11	6	WWLM6	M6 LOCK WASHER
12	6	SSSCM6X20	SCREW, SOCKET CAP
13	1	TTK32315	KNOB, 1-7/8OD, 3/8B, BLACK
14	1	SSSC01192	1/4-20 X 3 SOC CAP
15	1	WWFS3/8	WASHER, FLAT, SAE, 3/8
16	1	WWS307-1	WASHER, SPRING, BELVEL

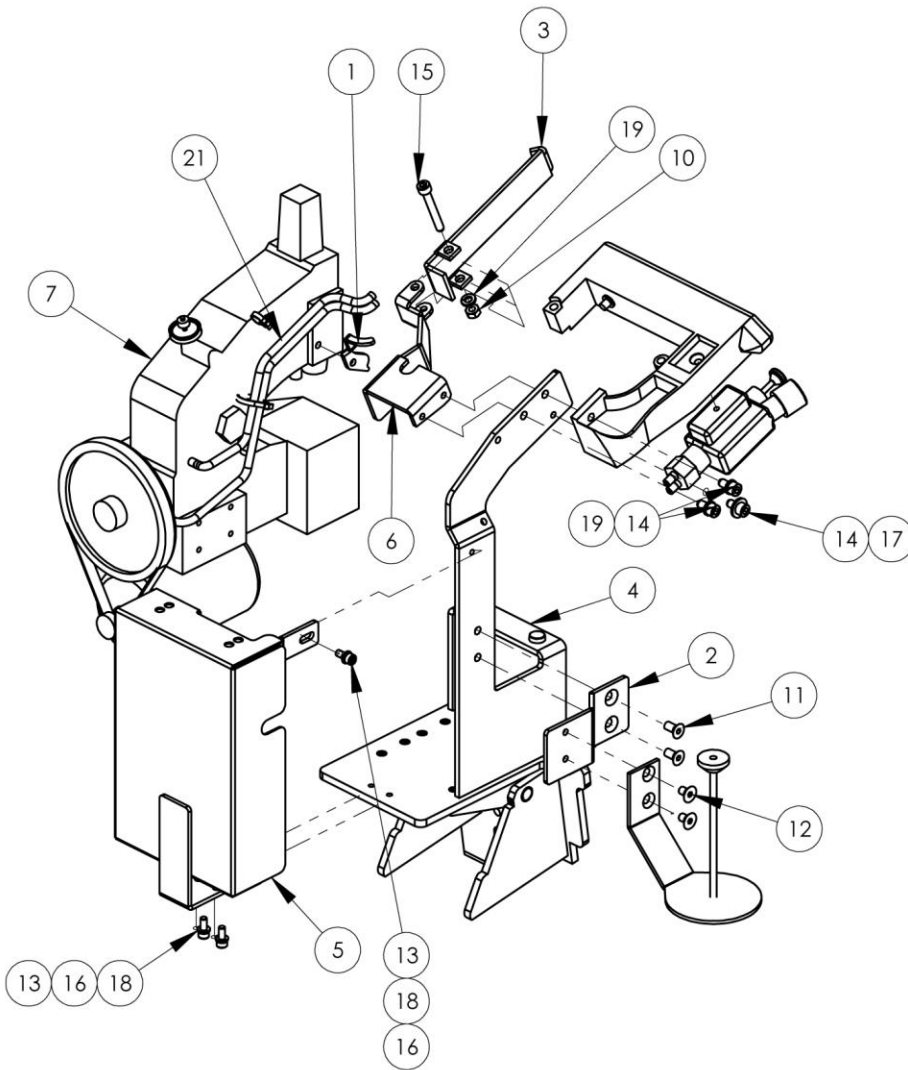

1392959 Closer Assembly

AAC Drawing Number
1392959 Rev 5

NO	QTY	PART #	DESCRIPTION	NO	QTY	PART #	DESCRIPTION
1	1	1386744	FOOT LEFT LEVER,BAG SEW	12	2	SSFCM6X10	M6 X 20 FLAT ALLEN
2	1	1388177	POST, THREAD STAND,BC1	13	3	SSSCM5X12	M5 X 12 SOC CAP SC
3	1	1389228	LATCH, BAG CLOSER	14	3	SSSCM6X12	M6X12 SOC CAP SCREW
4	1	1392163	SUPPORT, BASE BAG CLOSER	15	1	SSSCM6X45	M6X45 SOC CAP SCREW
5	1	1392960	GUARD,BELT	16	3	WWFM5	WASHER, FLAT, M5 I.D.
6	1	1393836	BRACKET,HANDLE	17	1	WWFS1/4	WASHER,FLAT,SAE,1/4
7	1	BC-1	BORDER CLOSER MACHINE	18	3	WWLM5	M5 LOCK WASHER
8	1	FF770018-1	PLUG, 3 POS, UML2	19	3	WWLM6	WASHER,LOCK,M6
9	3	FF770251-3	CONN,UML2,PIN,F,14	20	.17 ft	ZTH3/4B	HEAT SHRINK TUBING
10	1	NNHM6X1.0	M6 X 1.0 HEX NUT	21	1	MM5229K54	TUBING, 1/8"IDX1/4"OD
11	2	SSFC05032	1/4-28 X 1/2 FLAT ALN CAP				

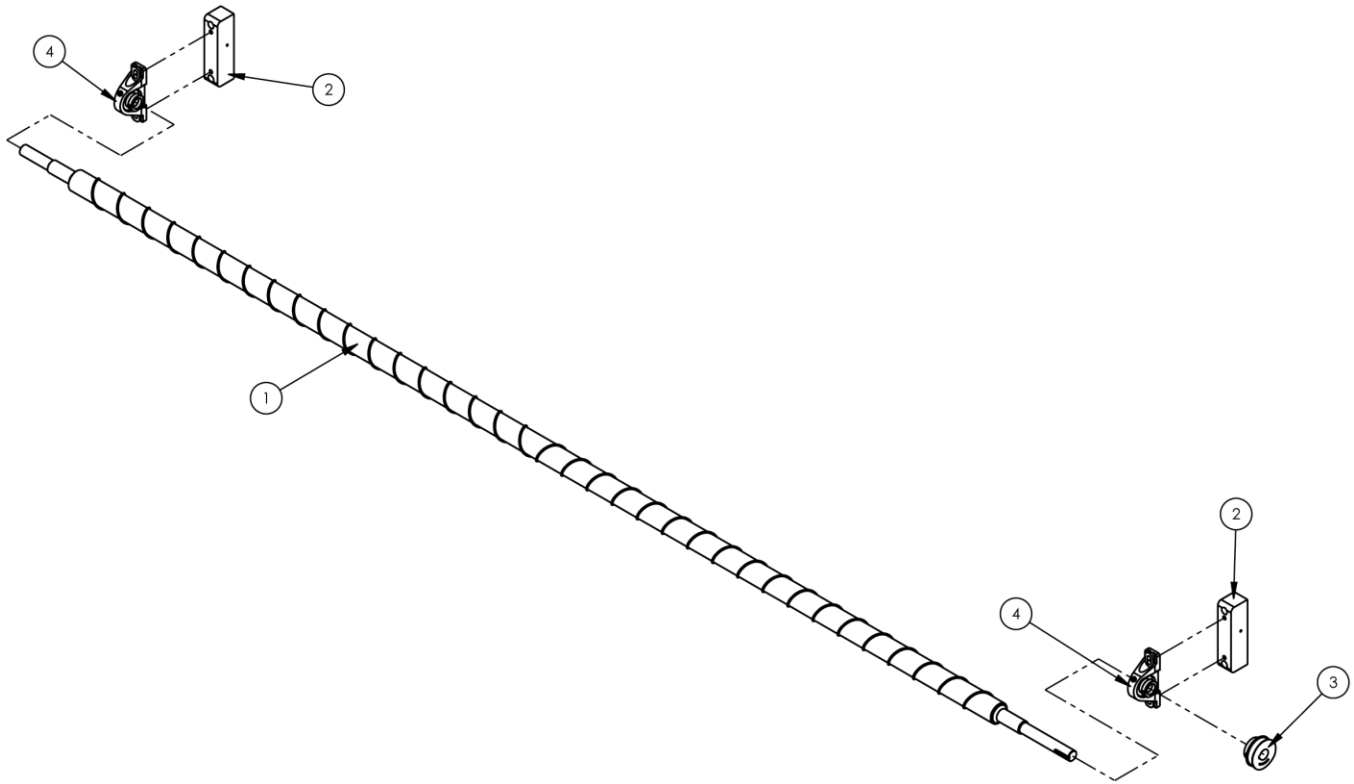

1392151 B Pole Assembly

AAC Drawing Number 1392151 Rev 1

NO.	QTY	PART #	DESCRIPTION
1	1	1392110	ROLL, SPIRAL FLIGHTED
2	2	1392150	MOUNTING BLK, BEARING
3	1	1392156	PULLEY, CLUTCH, 20T, 25mm
4	2	BBNAP205-25	BEARING, PILLOWBLOCK

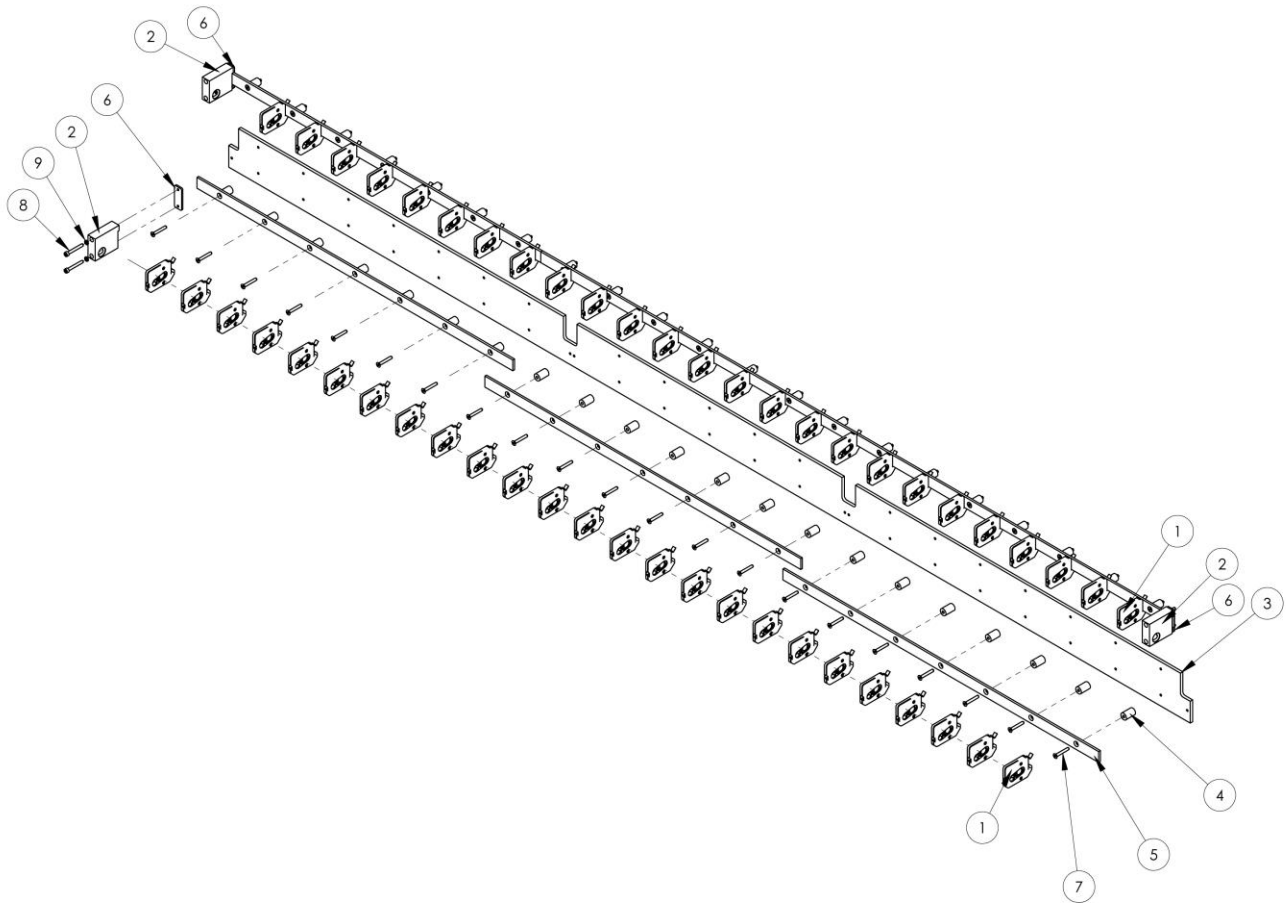

1389274 Dual Thread Break Detector Assembly

AAC Drawing Number 1389274 Rev 3

NO	QTY	PART #	DESCRIPTION
1	50	1386421	THREAD BREAK DETECT MOD
2	3	1388717	BRACKET,SENSOR,NEW STYLE
3	1	1389275	PLATE, DUAL THREAD STOP
4	42	1392325	STAND-OFF, RAIL
5	6	1392326	BAR,SENSOR MTG,MIDDLE
6	3	1392902	PLATE,NUT,M5X27
7	42	SSFCM5X35	SCREW,FLAT ALLEN CAP
8	6	SSSCM5X40	SCREW,SOCKET CAP,M5X40
9	6	WWLM5	M5 LOCK WASHER

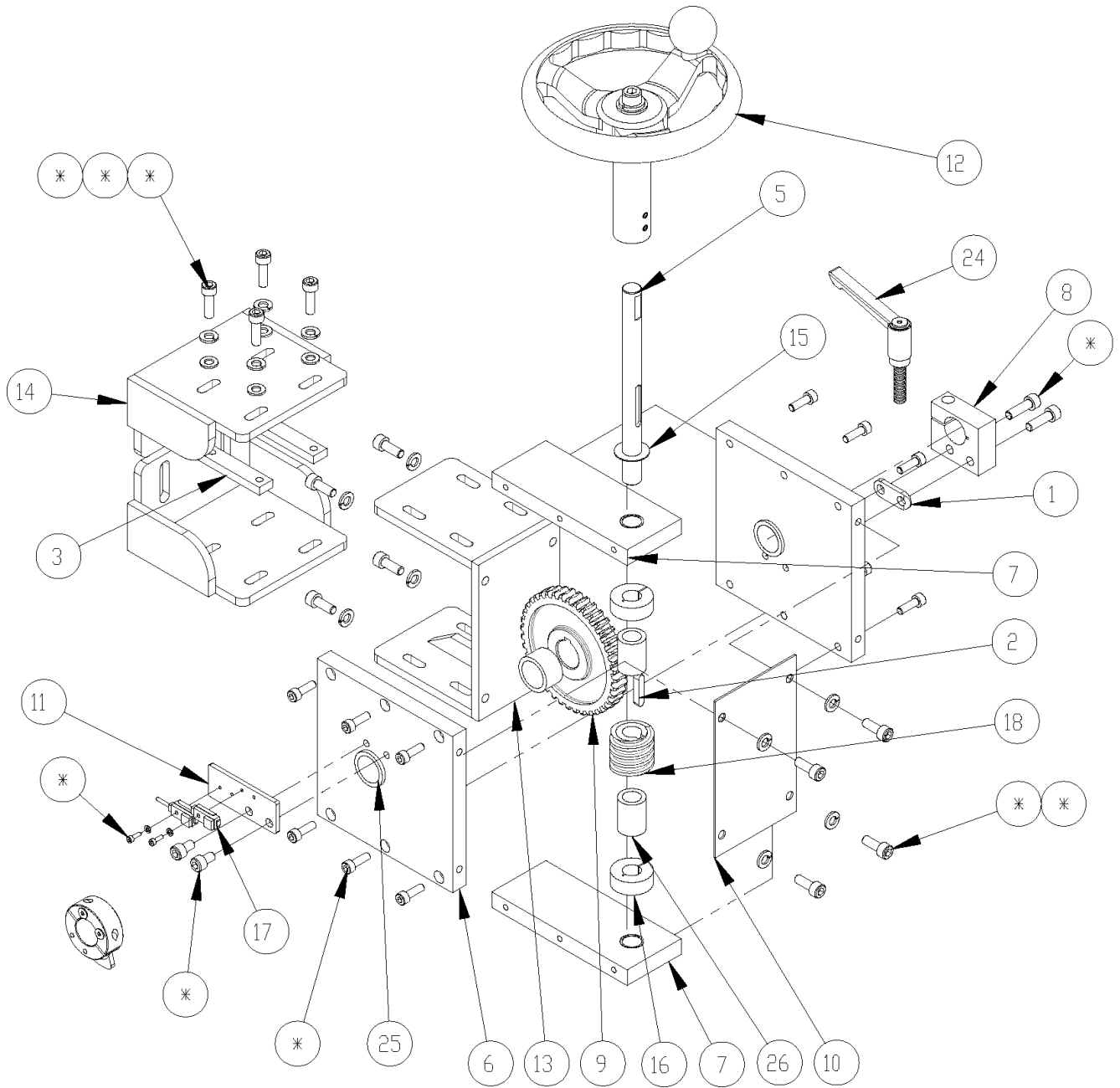

1393875 Footlift Adjusting Knob Assembly

AAC Drawing Number 1393875 Rev 0

NO.	QTY	PART #	DESCRIPTION
1	1	1331725	PLATE,WASHER,.266@.75
2	1	1389713	5MM X 5MM X 25MM KEY
3	2	1392004	PLATE,NUT,M6
4	1	1392373	INDICATOR, FOOT HEIGHT
5	1	1392482	SHAFT,ADJUSTING
6	2	1392484	PLATE,GEAR MTG
7	2	1392486	PLATE,WORM MTG
8	1	1392487	CLAMP
9	1	1392492	GEAR,WORM, 12P,14.5 DEG
10	1	1392591	PLATE,COVER,FOOT ADJ
11	1	1392710	PLATE,SENSOR MTG
12	1	1392998	WHEEL,FOOT LIFT
13	1	1393878	BRKT,FOOR ADJ MTG
14	2	1393882	BRKT,REAR
15	1	BBTRA815	WASHER,THRUST,STEEL 1/2
16	2	CCCL8F	CLAMP COLLAR- 1/2
17	2	FFGXL8FC5	PROX. SWITCH
18	1	MM57545K527	WORM,12P,1.0 OD,0.5B
19	2	SSSCM2.5X8	M2.5-0.45 X 8 SOC CAP
20	12	SSSCM5X16	M5-0.8 X 16 SOC CAP
21	2	SSSCM6X10	M6-1.0 X 10 SOC CAP
22	8	SSSCM6X16	M6-1.0 X 16 SOC CAP
23	6	SSSCM6X20	M6-1.0 X 20 SOC CAP
24	1	TTH6324K650	M8X1.25X32MM STUD
25	3	UU20-26X15	BEARING,BRONZE,20MM ID
26	2	UUAA744-03	BEARING, .5 X.75X 1.00
27	4	WWFM6	6MM FLAT WASHER
28	12	WWL1/4	1/4 LW

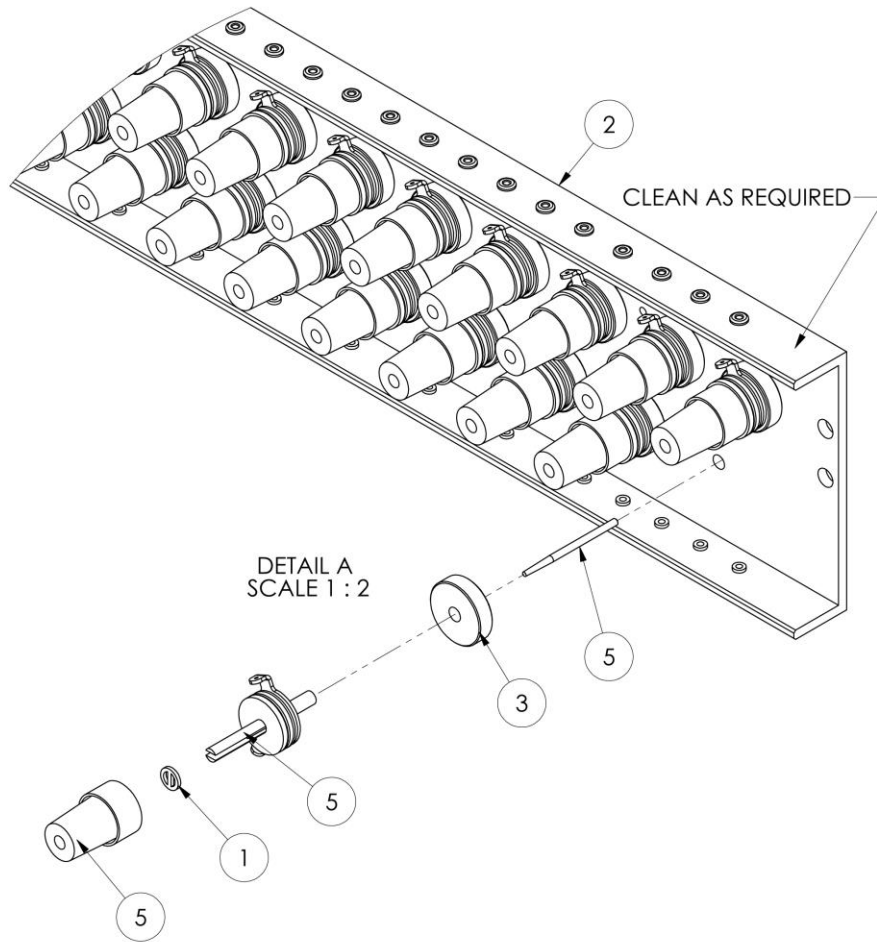

1392291 Thread Tension Guide Assembly

AAC Drawing Number 1392291 Rev 7

NO	QTY	PART #	DESCRIPTION
1	*107	1389915	WASHER, THREAD TENS. OPEN
2	1	1392290	GUIDE, THREAD GUIDE
3	107	1392308	SPACER, THREAD TENSION
4	107	1392987	PIN, TENSION OPENER, LONG
5	107	SCT1392	TENSION ASSY, 1392

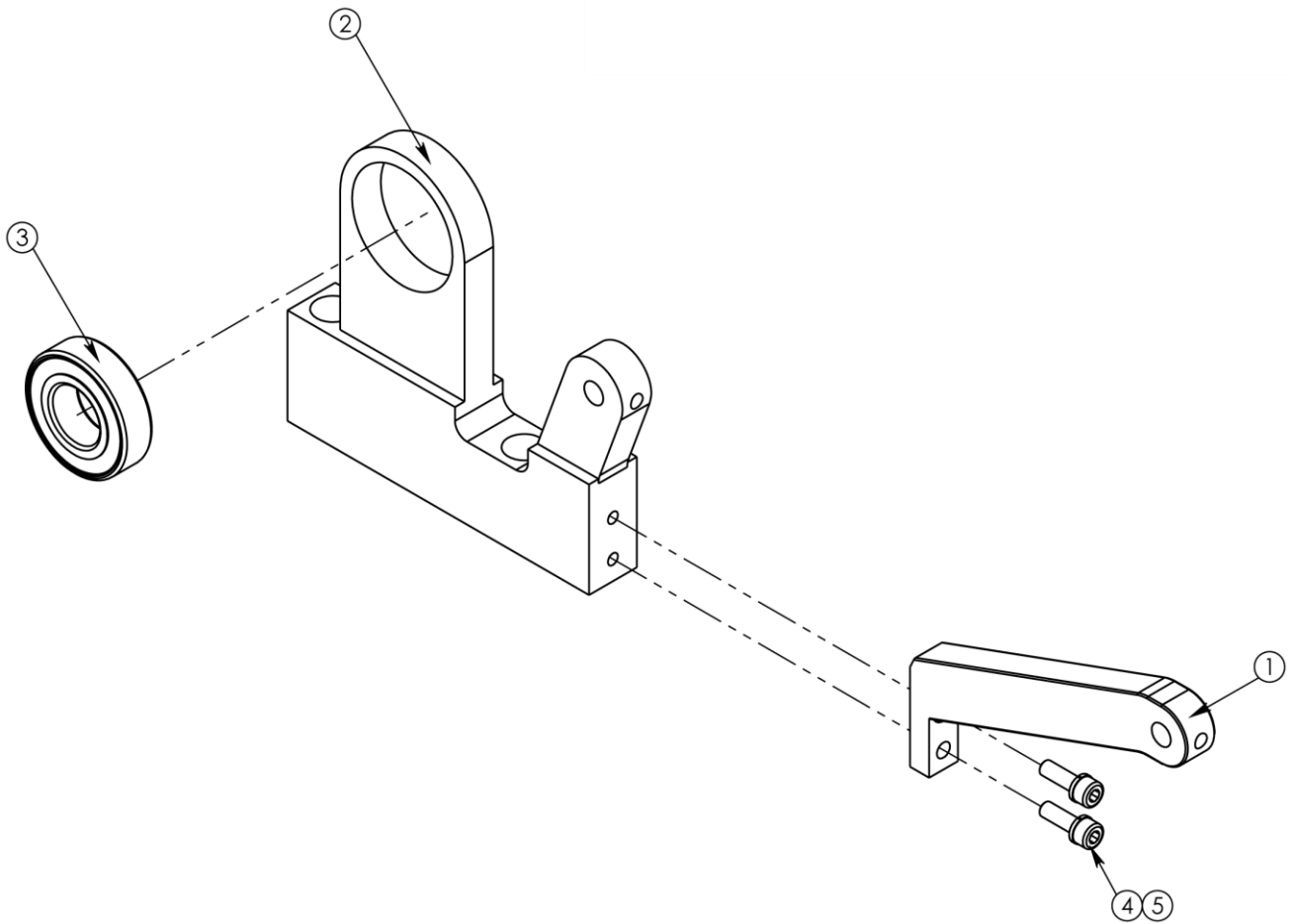

1392304 Bearing Butterfly Assembly

AAC Drawing Number 1392304 Rev 0

NO.	QTY	PART #	DESCRIPTION
1	1	1392221	GUIDE, LOOPER THREAD(4-082A-2)
2	1	1392491	MOUNT, ROLLER BEARING
3	1	BB60042RS	BEARING,BALL,20 ID,42 OD
4	2	SSSCM5X16	SCREW,SOC CAP,M5-0.8 X 16
5	2	WWLM5	M5 LOCK WASHER

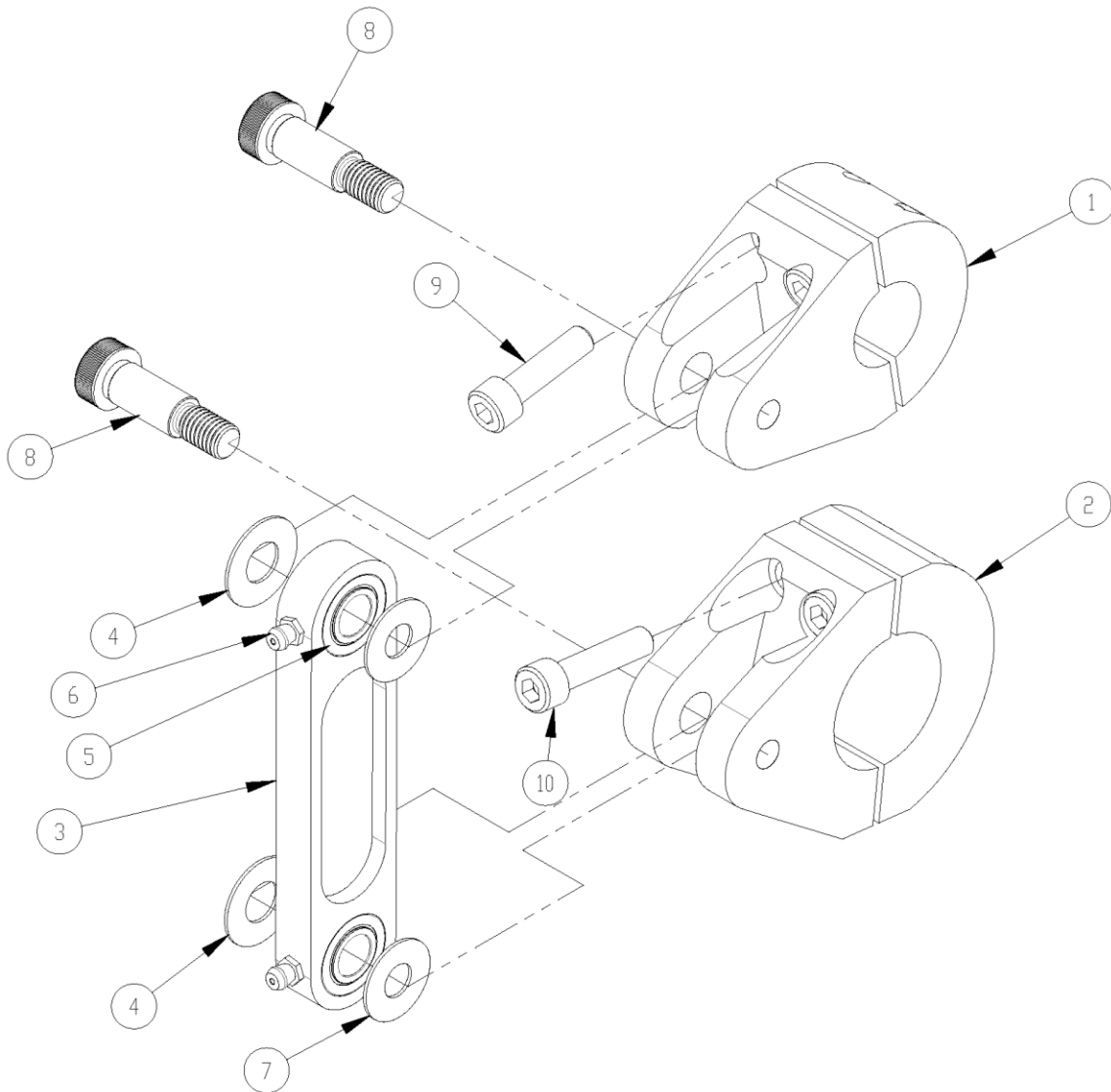

1392846 Butterfly Drive Assembly

AAC Drawing Number 1392846 Rev 2

NO.	QTY	PART #	DESCRIPTION
1	1	1389010	CRANK,FRONT BUTTERFLY
2	1	1392835	CRANK,FRONT BUTTERFLY
3	1	1392836	LINK,BUTTERFLY DRIVE
4	2	BBAS1226	WASHER,THRUST,12MM ID
5	2	BBNA4901A2RSR	BEARING,NEEDLE,12MM ID
6	2	MM1105K71	GREASE FITTING, M6X1
7	2	MM5909K71	WASHER,THRUST,10MM ID
8	2	SSASM12M25	SCREW,ALLEN SHOULDER
9	4	SSSCM8X30	M8-1.25 X 30 SOC CAP
10	4	SSSCM8X35	M8-1.25 X 35 SOC CAP

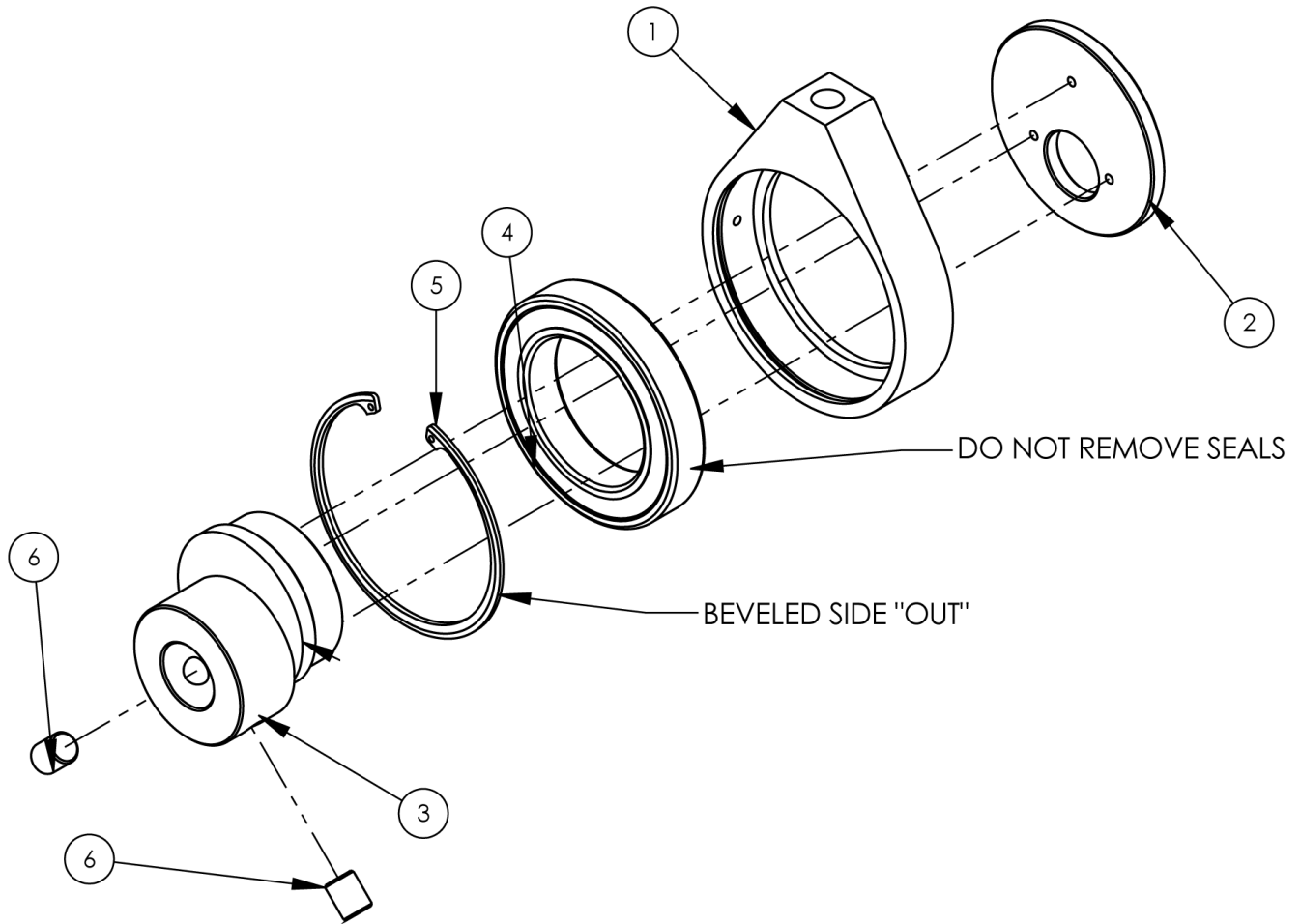

1389024 Large Eccentric Assembly

AAC Drawing Number 1389024 Rev 3

NO	QTY	PART #	DESCRIPTION
1	1	2-060	NEEDLE BAR ECCENTRICS
2	1	2-061	NDL BAR ECCENTRIC PLATE
3	1	2-062M	ECCENTRIC INSERT, LARGE
4	1	BB60162RS	BEARING, RADIAL, SEALED
5	1	MMN1302475	RING, RET, BLVD, INT, 4.75"
6	2	SSSSM16X20	M1 6X2X20 SET SCREW

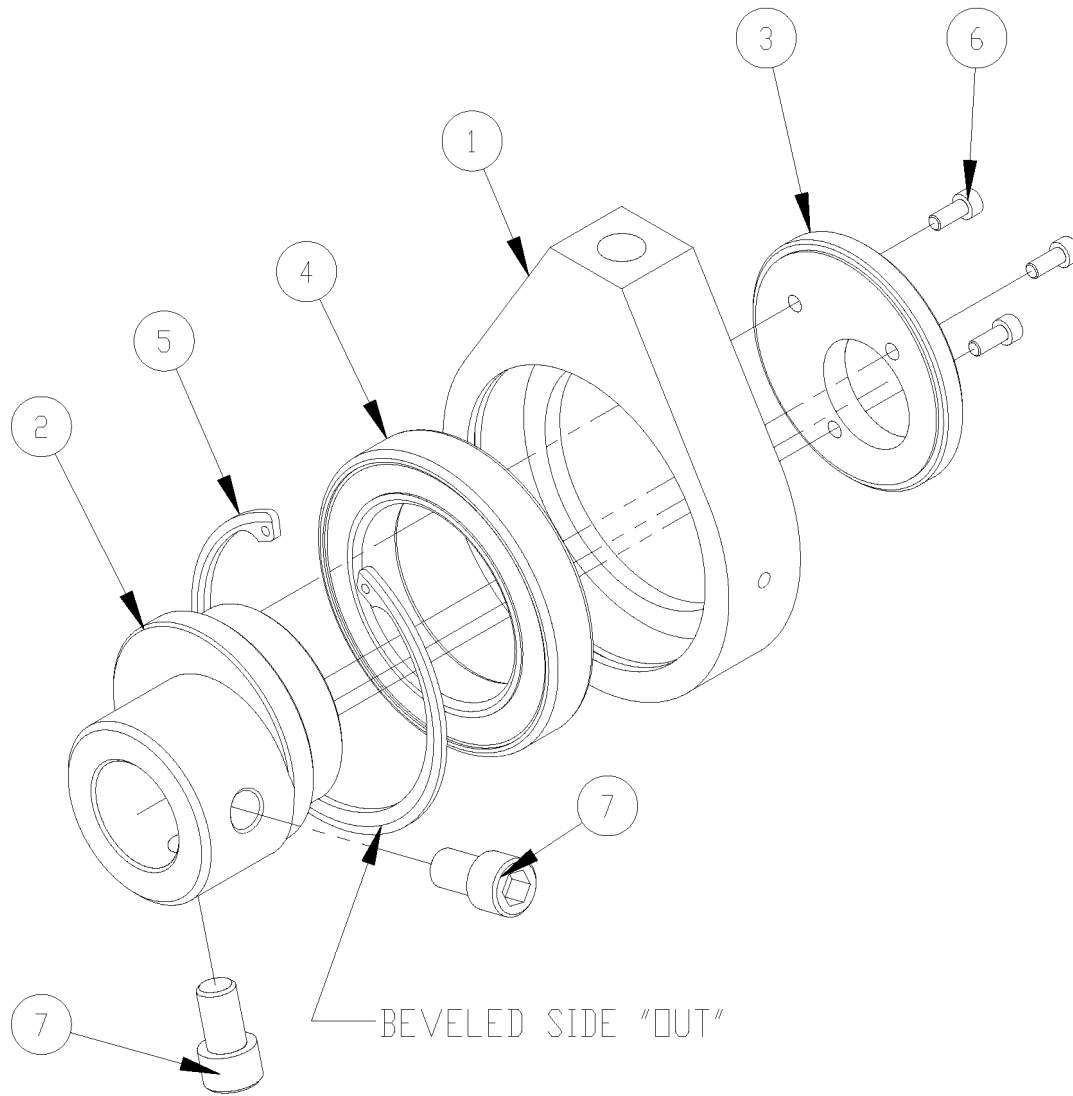

1389025 Small Eccentric Assembly

AAC Drawing Number 1389025 Rev 4

NO	QTY	PART #	DESCRIPTION
1	1	2-063A	ECCENTRIC, LINKAGE
2	1	2-064BM	ECCENTRIC INSERT, SMALL
3	1	2-065	CAP, LOOPER ECENTRIC
4	1	BB60132RS	BEARING, RADIAL, SEALED
5	1	MMN1302375	RING, RET, BLVD, INT, 3.75"
6	3	SSSCM5X12	M5 X 12 SOC CAP SC
7	2	SSSCM12X20	SCREW, M12 X 20

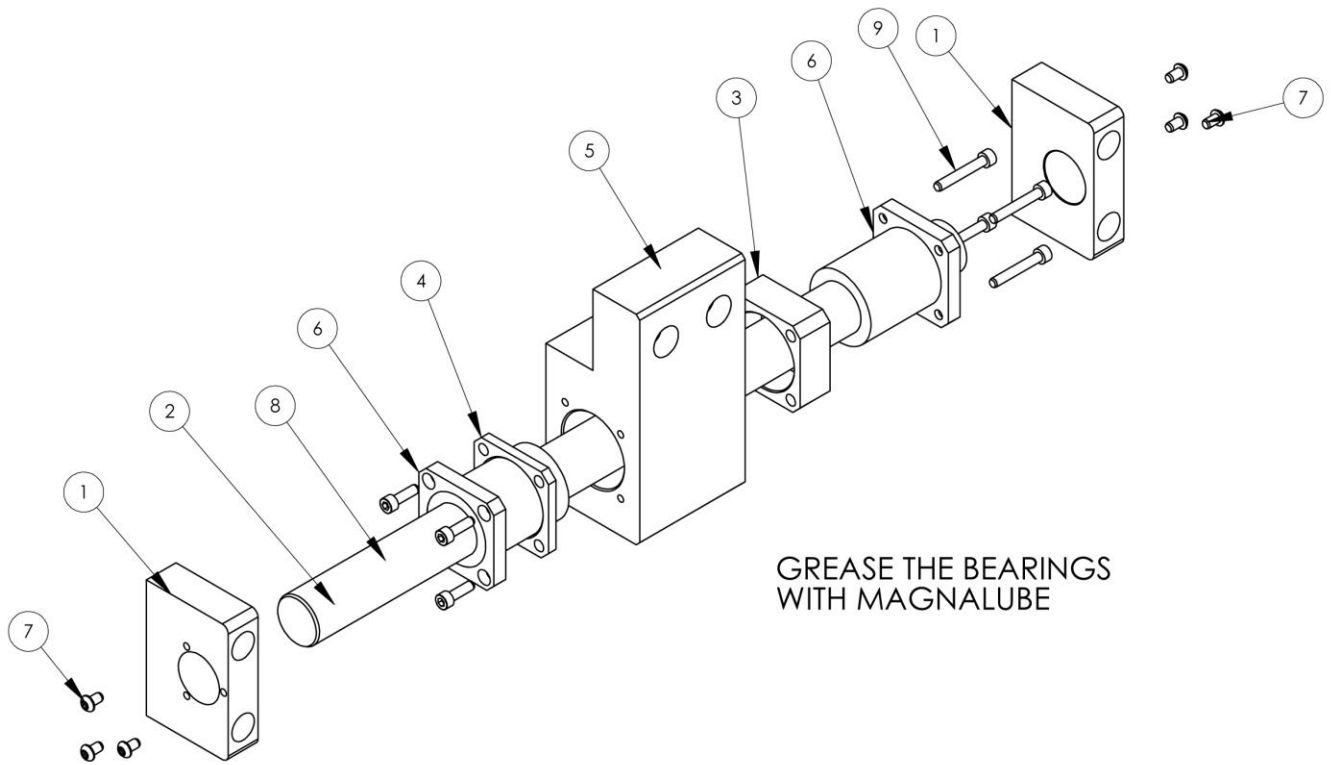

1388222 Front Linear Slide, 35MM

AAC Drawing Number 1388222 Rev 2

NO	QTY	PART #	DESCRIPTION
1	2	1388221	BRKT,SLIDE SUPPORT,35MM
2	1	1388223	SHAFT,SLIDE,35MM
3	1	1388224	SPACER, BEARING,35MMX1"
4	1	1388225	SPACER, BEARING,35MMX1/4"
5	1	4-001A	BLOCK,SLIDE,35MM SHAFT
6	2	BBSMK35GUU	BEARING,LIN,FLG,35MM
7	6	SSBCM6X10	SCREW,SOCKET CAP
8	4	SSSCM6X20	M6 X 20, SOC CAP
9	4	SSSCM6X40	SCREW, SOCKET CAP, M6X40

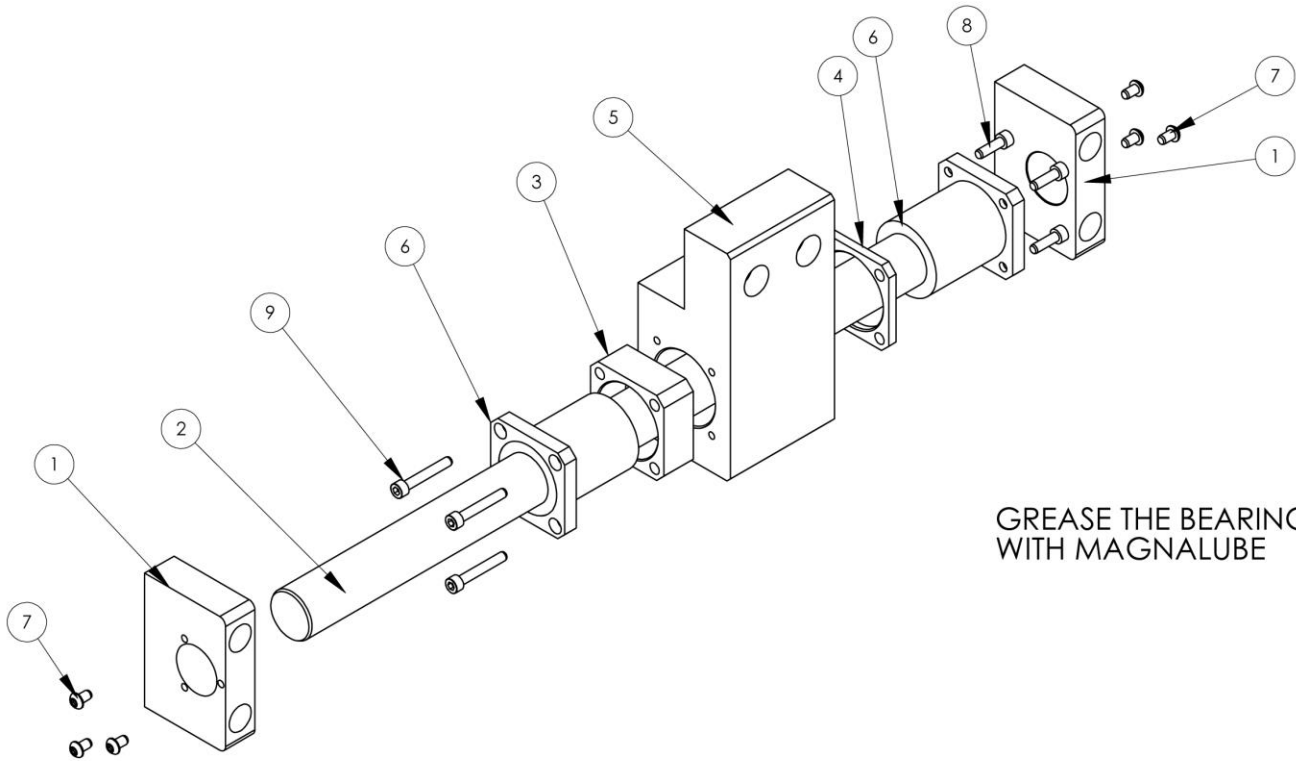

1388227 Right Linear Slide, 35MM

AAC Drawing Number 1388227 Rev 2

NO	QTY	PART #	DESCRIPTION
1	2	1388221	BRKT,SLIDE SUPPORT,35MM
2	1	1388223	SHAFT,SLIDE,35MM
3	1	1388224	SPACER, BEARING,35MMX1"
4	1	1388225	SPACER, BEARING,35MMX1/4"
5	1	4-001A	BLOCK,SLIDE,35MM SHAFT
6	2	BBSMK35GUU	BEARING,LIN,FLG,35MM
7	6	SSBCM6X10	SCREW,SOCKET CAP
8	4	SSSCM6X20	M6 X 20, SOC CAP
9	4	SSSCM6X40	SCREW, SOCKET CAP, M6X40

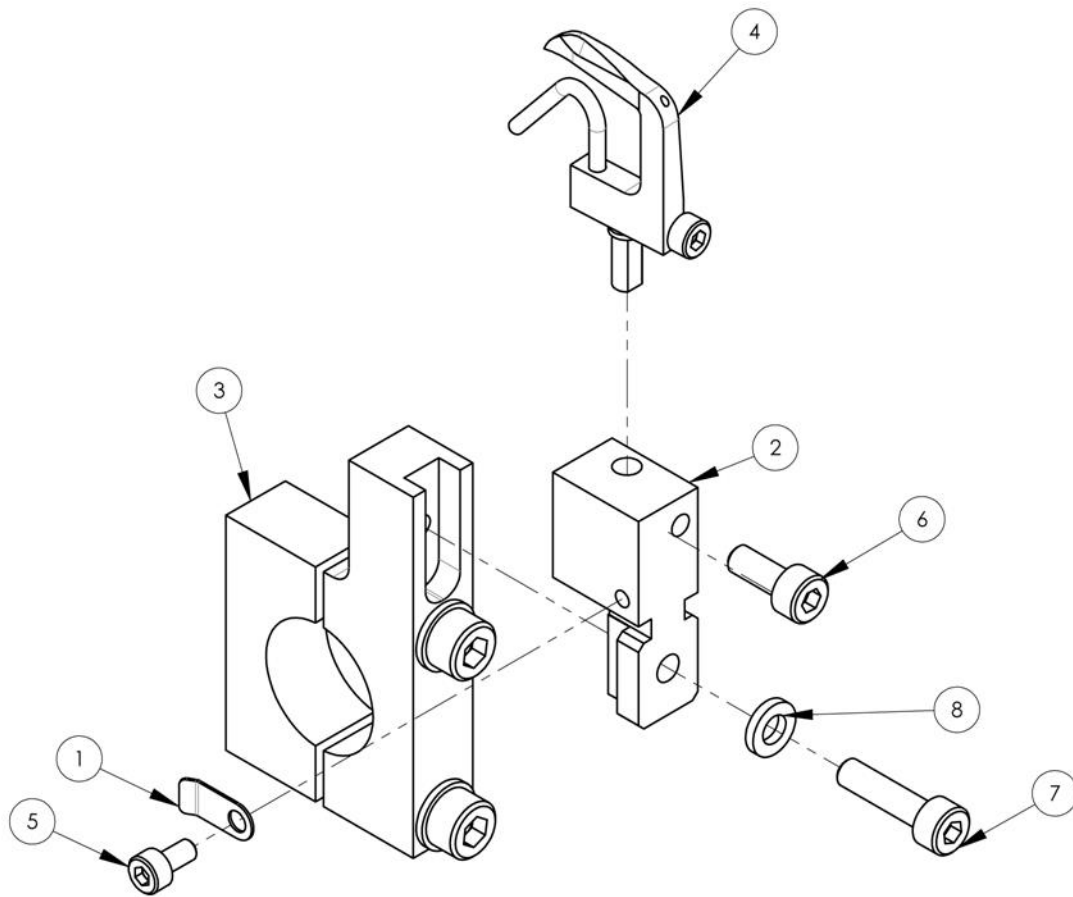

1392329 Looper Holder, LH

AAC Drawing Number 1392329 Rev.6

NO	QTY	PART #	DESCRIPTION
1	1	1392003	CLIP,THREAD
2	1	1392005	LOOPER HOLDER, LH
3	1	1392145	CLAMP, LOOPER HOLDER
4	1	P3-0146-N1	LOOPER,NEW STYLE
5	1	SSSCM3X6	M3-0.5 X 6 SOC CAP
6	1	SSSCM4X10	M4-0.4 X 10 SOC CAP
7	1	SSSCM4X16	M4-0.7 X 16 SOC CAP
8	1	WWFM4.3	WASHER, FLAT 4MM

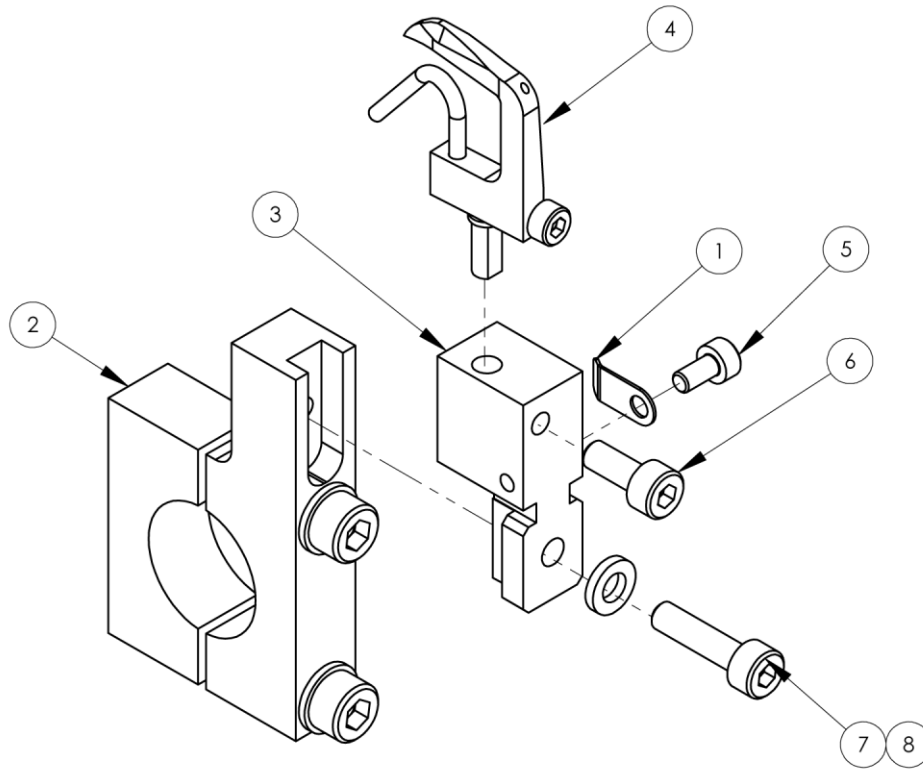

1392347 Looper Holder Assembly, RH

AAC Drawing Number 1392347 Rev.5

NO	QTY	PART #	DESCRIPTION
1	1	1392003	CLIP,THREAD
2	1	1392145	CLAMP, LOOPER HOLDER
3	1	1392346	LOOPER HOLDER,RH
4	1	P3-0146-N1	LOOPER,NEW STYLE
5	1	SSSCM3X6	M3-0.5 X 6 SOC CAP
6	1	SSSCM4X10	M4-0.4 X 10 SOC CAP
7	1	SSSCM4X16	M4-0.7 X 16 SOC CAP
8	1	WWFM4.3	WASHER, FLAT 4MM

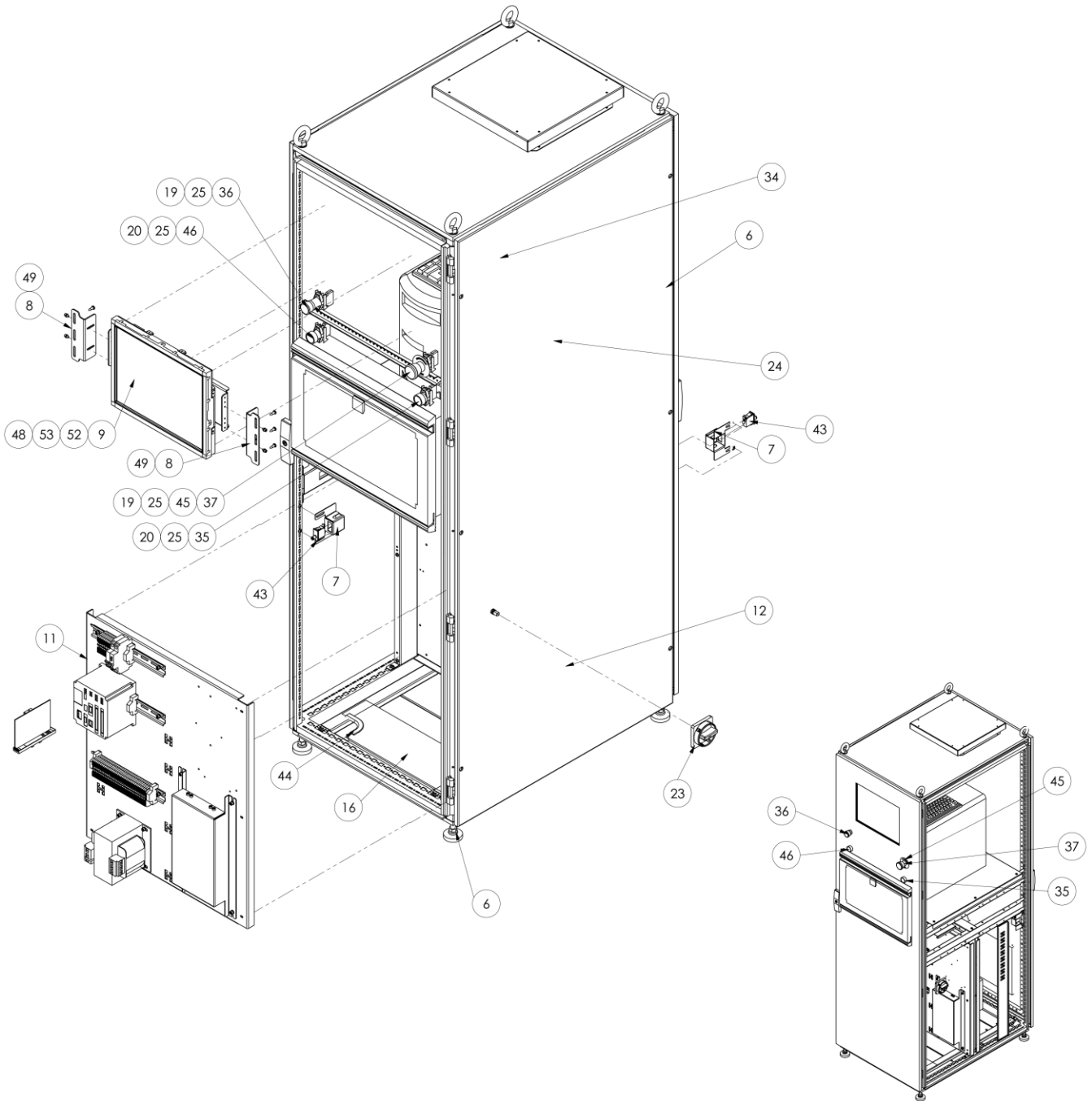

CA-19076-1-007924

1392364 Control Cabinet Assembly

AAC Drawing Number 1392364 Rev18

NO	QTY	PART #	DESCRIPTION	NO	QTY	PART #	DESCRIPTION
1	AR	1392-WD1	WD,BACK PANEL	28	1*	EEB2E10A	CABLE,POWER,10M,SERVO
2	AR	1392-WD2	WD,QUILTER PANEL	29	1*	EEB51CE05A	CABLE,POWER,5M,SERVO
3	1	4080-4215A	CABLE,3 PIN FM MOLEX	30	1*	EEJEPMCW6022	TERMINATION,BLOCK
4	1*	51175B	MEMORY KEY,128MB	31	3*	EEJEPMCW600301	CABLE,MCHTRINK M2 W/CORE
5	AR	120280	PCI SERIAL ADAPTOR	32	1*	EEJZSPCMP0205B	ENC,CABLE ASSY,5M
6	1	1388431	ENCLOSURE, COMPUTER 1392	33	1*	EEJZSPCMP0210B	ENC,CABLE ASSY,10M
7	2	1388437	ENCLOSURE ,SENSOR,DOOR	34	1	EEL237228	KEYBOARD, USB
8	2	1388708	BRACKET, TOUCHSCREEN	35	1	EEPF3	BUTTON,PUSH,22MM, GREEN MO
9	1	1388986	15" TOUCHSCREEN ASSEMBLY	36	1	EEPLMP45	BUTTON,PUSH,22MM,YELLOW
10	1	1392036	SHELF, KEYBOARD	37	1	EEPMTS44	E-STOP BUTTON, TWIST REL.
11	1	1392366	BACKPLANE, FRONT SIDE ASM	38	3*	FF8908-2	WIRE,STR,#8,PVC,RED
12	1	1392367	BACKPLANE, BACK SIDE ASM	39	3*	FF8908-10	WIRE,STR,#8,PVC,BLK
13	1*	1392660	CABLE, FLORES. LIGHT	40	3*	FF8908-13	WIRE,STR,#8,PVC,BLU
14	1*	1392696	CABLE ASSY,MP2300,SERIAL	41	*15	FF19504	CABLE,STOW,3X16 AWG,
15	1*	1392697	PENDANT ASSY,QUILTER	42	18*	FF31572787	WIRE,STR,#10,PVC,GRN/YEL
16	1	1392994	PANEL, ACCESS	43	2	FFE6930A	SWITCH,INTEROCK,DOOR,SPDT
17	1*	DONGLE1	E-Z PATTERN DESIGN SECURITY DONGLE	44	5**	MM100-1/8	DOOR TRIM - BLACK
18	1*	DONGLE2	E-Z QUILTER SECURITY DONGLE	45	1	MM800E15YE112	E-STOP LEGEND PLATE
19	2	EE3X01	BLOCK,P.B. CONTACT, N.C. (RED)	46	1	MM800EPF1	BUTTON,PUSH 22MM, WHI, MO
20	2	EE3X10	BLOCK,P.B. CONTACT, N.O. (GRN)	47	50**	MMLSSBB01210	FOAM, URETHANE, 1/8X1
21	1*	EE194EE63PE	DISCONNECT PE,40/63A,IEC	48	4	SSSCM4X8	SCREW,SOC CAP,M4-0.7X8
22	1*	EE194EE631753	DISCONNECT,3POLE,63A,IEC,	49	50*	SSZP#12040	SCREW,PAN SHEET METAL
23	1	EE194LHE6N175	DISCONNECT HANDLE,RED/YEL	50	4*	TT5828	TERMINAL,RING,#10 STUD
24	1	EE1392COMP	DELL COMP W/FLAT SCREEN	51	4*	TT190020028	TERMINAL,FASTON,F,.187X
25	4	EEA3L	LATCH,PUSH BUTTON	52	4	WWFM4.3	WASHER, FLAT, M4
26	1*	EEA11CE05A	CABLE,ENCODER,5M	53	4	WWL8	WASHER,LOCK,#8
27	1*	EEB2E05A	CABLE,POWER,5M,SERVO				

1392C-PD Pneumatic Diagram

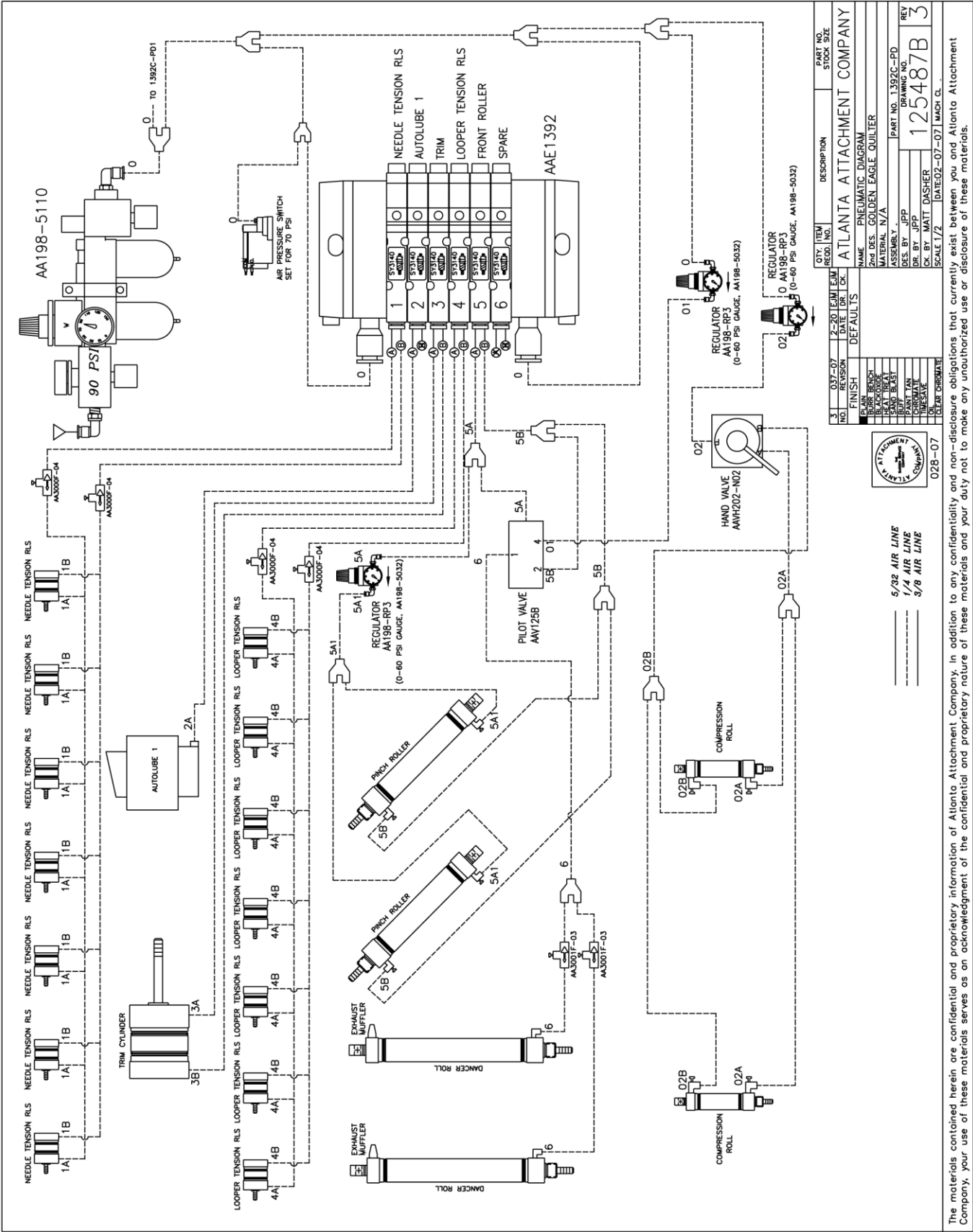

QTY.	ITEM	DESCRIPTION	PART NO.
3	037-07	REGULATOR	AA198-RP3
1	2-20	PILOT VALVE	AAV125B
1	DR	HAND VALVE	AAWH202-ND2
1	DK	REGULATOR	AA198-RP3
FINISH DEFAULTS			
NAME PNEUMATIC DIAGRAM			
2nd DES. GOLDEN EAGLE QUILTER			
MATERIAL N/A			
ASSEMBLY N/A			
DES. BY JPP			
DR. BY JPP			
CK. BY MATT DASHER			
SCALE 1/2			
DATE 02-07			
MACH. CL.			
DRAWING NO. 125487B			
REV. 3			



5/32 AIR LINE
1/4 AIR LINE
3/8 AIR LINE

The materials contained herein are confidential and proprietary information of Atlanta Attachment Company. In addition to any confidentiality and non-disclosure obligations that currently exist between you and Atlanta Attachment Company, your use of these materials serves as an acknowledgment of the confidential and proprietary nature of these materials and your duty not to make any unauthorized use or disclosure of these materials.

Atlanta Attachment Company (AAC) Statement of Warranty

Manufactured Products

Atlanta Attachment Company warrants manufactured products to be free from defects in material and workmanship for a period of eight hundred (800) hours of operation or one hundred (100) days whichever comes first. Atlanta Attachment Company warrants all electrical components of the Serial Bus System to be free from defects in material or workmanship for a period of thirty six (36) months.

Terms and Conditions:

- AAC Limited Warranty becomes effective on the date of shipment.
- AAC Warranty claims may be made by telephone, letter, fax or e-mail. All verbal claims must be confirmed in writing.
- AAC reserves the right to require the return of all claimed defective parts with a completed warranty claim form.
- AAC will, at its option, repair or replace the defective machine and parts upon return to AAC.
- AAC reserves the right to make the final decision on all warranty coverage questions.
- AAC warranty periods as stated are for eight hundred (800) hours or one hundred (100) days whichever comes first.
- AAC guarantees satisfactory operation of the machines on the basis of generally accepted industry standards, contingent upon proper application, installation and maintenance.
- AAC Limited Warranty may not be changed or modified and is not subject to any other warranty expressed or implied by any other agent, dealer, or distributor unless approved in writing by AAC in advance of any claim being filed.

What Is Covered

- Electrical components that are not included within the Serial Bus System that fail due to defects in material or workmanship, which are manufactured by AAC are covered for a period of eight hundred (800) hours.
- Mechanical parts or components that fail due to defects in material or workmanship, which are manufactured by AAC.
- Purchased items (sewing heads, motors, etc.) will be covered by the manufacturers (OEM) warranty.
- AAC will assist in the procurement and handling of the manufacturers (OEM) claim.

What Is Not Covered

- Parts that fail due to improper usage, lack of proper maintenance, lubrication and/or modification.
- Damages caused by; improper freight handling, accidents, fire and issues resulting from unauthorized service and/or personnel, improper electrical, plumbing connections.
- Normal wear of machine and parts such as Conveyor belts, "O" rings, gauge parts, cutters, needles, etc.
- Machine adjustments related to sewing applications and/or general machine operation.
- Charges for field service.
- Loss of time, potential revenue, and/or profits.
- Personal injury and/or property damage resulting from the operation of this equipment.

Declaración de Garantía

Productos Manufacturados

Atlanta Attachment Company garantiza que los productos de fabricación son libres de defectos de material y de mano de obra durante un período de ochocientos (800) horas de operación o cien (100) días, cual llegue primero. Atlanta Attachment Company garantiza que todos los componentes del Serial Bus son libres de defectos de material y de mano de obra durante un periodo de treinta y seis (36) meses.

Términos y Condiciones:

- La Garantía Limitada de AAC entra en efecto el día de transporte.
- Reclamos de la Garantía de AAC pueden ser realizados por teléfono, carta, fax o correo electrónico. Todo reclamo verbal tiene que ser confirmado vía escrito.
- AAC se reserva el derecho de exigir el retorno de cada pieza defectuosa con un formulario de reclamo de garantía.
- AAC va, según su criterio, a reparar o reemplazar las máquinas o piezas defectuosas devueltas a AAC.
- AAC se reserva el derecho para tomar la decisión final sobre toda cuestión de garantía.
- Las garantías de AAC tiene una validez de ochocientas (800) horas o cien (100) días, cual llega primero.
- AAC garantiza la operación satisfactoria de sus máquinas en base de las normas aceptadas de la industria siempre y cuando se instale use y mantenga de forma apropiada.
- La garantía de AAC no puede ser cambiada o modificada y no está sujeto a cualquier otra garantía implicada por otro agente o distribuida al menos que sea autorizado por AAC antes de cualquier reclamo.

Lo Que Está Garantizado

- Componentes eléctricos que no están incluidos dentro del sistema Serial Bus que fallen por defectos de materiales o de fabricación que hayan sido manufacturados por AAC, son garantizados por un período de ochocientas (800) horas.
- Componentes mecánicos que fallen por defectos de materiales o de fabricación que hayan sido manufacturados por AAC, son garantizados por un período de ochocientas (800) horas.
- Componentes comprados (Motores, Cabezales) son protegidos debajo de la garantía del fabricante.
- AAC asistirá con el manejo de todo reclamo de garantía bajo la garantía del fabricante.

Lo Que No Está Garantizado

- Falla de repuestos a raíz de uso incorrecto, falta de mantenimiento, lubricación o modificación.
- Daños ocurridos a raíz de mal transporte, accidentes, incendios o cualquier daño como resultado de servicio por personas no autorizados o instalaciones incorrectas de conexiones eléctricas o neumáticas.
- Desgaste normal de piezas como correas, anillos de goma, cuchillas, agujas, etc.
- Ajustes de la máquina en relación a las aplicaciones de costura y/o la operación en general de la máquina.
- Gastos de Reparaciones fuera de las instalaciones de AAC
- Pérdida de tiempo, ingresos potenciales, y/o ganancias.
- Daños personales y/o daños a la propiedad como resultado de la operación de este equipo.

