

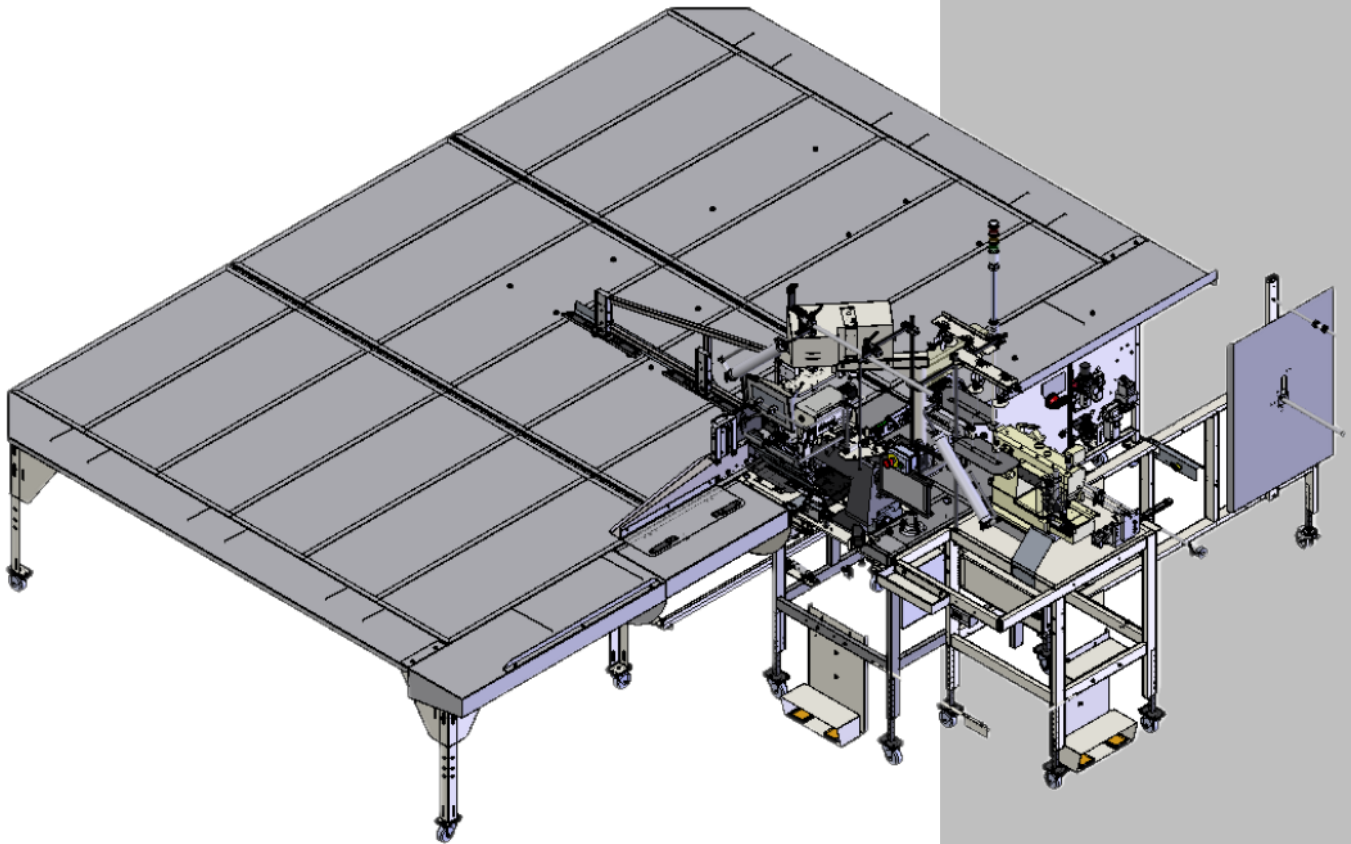

Model **1335B**

Revision 1.5 Updated August 8, 2023(wr)

Technical Manual / Parts Lists



Atlanta Attachment Company

362 Industrial Park Drive

Lawrenceville, GA 30046

770-963-7369 • www.atlatt.com

ATLANTA ATTACHMENT COMPANY, INC.

Confidential and Proprietary Information

The materials contained herein are confidential and proprietary information of Atlanta Attachment Company. In addition to any confidentiality and non-disclosure obligations that currently exist between you and Atlanta Attachment Company, your use of these materials serves as an acknowledgment of the confidential and proprietary nature of these materials and your duty not to make any unauthorized use or disclosure of these materials.

All materials contained herein are additionally protected by United States Copyright law and may not be used, disclosed, reproduced, distributed, published, or sold without the express written consent of Atlanta Attachment Company, which consent may be withheld in Atlanta Attachment Company's sole discretion. You may not alter or remove any copyright, trademark, or other notice from copies of these materials.

Patents & Patents Pending

The sale of this product does not sell or otherwise transfer any license or other rights under any US Patent or other corresponding foreign patent.

This equipment is manufactured under one or more of the following patents:

4,280,421 • 4,432,294 • 4,466,367 • 4,644,883 • 5,134,947 • 5,159,889 • 5,203,270 • 5,373,798 • 5,437,238 • 5,522,332 • 5,524,563 • 5,562,060 • 5,634,418 • 5,647,293 • 5,657,711 • 5,743,202 • 5,865,135 • 5,899,159 • 5,915,319 • 5,918,560 • 5,924,376 • 5,979,345 • 6,035,794 • 6,055,921 • 6,202,579 • 6,279,869 • 6,295,481 • 6,494,225 • 6,523,488 • 6,574,815 • 6,802,271 • 6,834,603 • 6,968,794 • 6,994,043 • 7,543,364 • 7,574,788 • 7,647,876 • 7,735,439

Foreign Patents: 9-520,472 • 0,537,323 • 92,905,522.6 • 96,936,922.2 • 2,076,379 • 2,084,055
Other US and Foreign Patents Pending.

IMPORTANT

It is important to read and understand the information contained within this manual before attempting to operate the machine. Atlanta Attachment Co., Inc. shall not be held liable for damage resulting from misuse of the information presented within, and reserves the right to change the information contained within, without prior notification.

Contents

Important Safety Instruction	0
Liability	1
Safety Equipment on the Machines	2
Protective Eyewear	3
Important Notices.....	4
Maintenance	6
Repair	7
A Word to the End-User	8
Safety Precautions.....	8
General Machine Data	9
Physical Dimensions.....	9
Light Tower Functions.....	9
Installation.....	9
Operation.....	10
Control Panel	10
Power "ON"	10
Loading the Gusset and Flange Material into the Flanger Module	10
Loading and Adjusting the Folders.....	11
Adjusting the Active Edge Guiding.....	11
Starting the Automatic Cycle.....	11
Finishing the Panel.....	12
Ruffler Setting.....	12
Ruffle Size Adjustments	12
Sizing the Panel.....	13
Service.....	14
General Machine Adjustments.....	14
Air Pressure.....	14
Soffie Jets.....	14
Electric Eye Sensor Adjustment	14
Reflective Tape Maintenance	14
Electrical	15
Ground	15
Touch Screen	15
Stepper Control Box	16
Stepper Control Box AP-28-800Y1	17
Control Screens.....	18

Technical Manual & Parts Lists

Sewing Head and Motor	27
Ruffler Drive Assembly	27
Edge Guide Assembly	27
Rotator Assembly	27
Puller Assembly	28
Rear Conveyor Assembly	28
1334 Auto Flanging Unit	29
Sequence of Operation	29
11335BS88CP Recommended Spare Parts List	29
Maintenance	30
Daily	30
Weekly	30
Cleaning Electric Eyes and Sensors	30
Programming Sequence for EFKA Motor	32
Assembly Drawings & Parts Lists	33
11335BS88CP Auto Pillowtop Ruffler PLC	34
1335000 AIR TABLE ASSY, AUTO	35
1335-0190 BLOWER ASSEMBLY	37
1335030 AIR TABLE ASSEMBLY	39
1335040 AIR TABLE ASSEMBLY, RIGHT	40
1335050 LEG ASSEMBLY	41
1335130 TRAP DOOR ASSEMBLY	42
11334BY28P Auto Flanging Module	43
1334-1000A Sewing Head Assembly	44
1334-1200 MATERIAL GUIDE ASSEMBLY	46
1334-2000 FRAME ASSEMBLY	47
13351100 MAIN CONSOLE ASSY, PLC	51
1335060 PNEUMATIC PANEL ASSEMBLY	53
13351030 REAR CONVEYOR ASSEMBLY	55
13351045 ROTATE & CLAMP ARM ASSEMBLY	59
13351109 ELECTRICAL PANEL ASSY 1335BS	64
13351110 STAND, HEAD, & MOTOR, 300UX5	66
13351111 MAIN SOLENOID PANEL ASSY	87
13351012 ROTATE ASSEMBLY	89
1334BP-WD WIRING DIAGRAM I/O CONTROL	93
1334BP-WD1 WIRING DIAGRAM PLC I/O L	94

1335BP-WD2 WIRING DIAGRAM POWER..... 98
1335B-PD1 PNEUMATIC DIAGRAM..... 99

Important Safety Instruction



This part of the Instruction Material is provided for the safe use of your equipment. It contains important information to help work safely with the unit and describes the dangers inherent in machinery. Some of these dangers are obvious, while others are less evident.

Mandatory Information

All persons operating and/or working on the 1335AY88 Auto Pillowtop Ruffler should read and understand all parts of the Safety Instructions. This applies, in particular, to persons who only operate and/or work on the unit occasionally (e.g., for maintenance and repair). Persons who have difficulty reading must receive particularly thorough instruction.

Scope of the Instruction Material

- The Instruction Material comprises:
- Safety information
- Operator Instructions
- Electrical and Pneumatic diagrams

And may also include.

- A list of recommended spare parts
- Instruction Manual(s) for components made by other manufacturers.
- The layout and installation diagram containing information for the installation.

Intended Use

Our machines are designed and built-in line with state-of-the-art and the accepted safety rules. However, all machines may endanger the life and limb of their users and/or third parties and be damaged or cause damage to other property, particularly if they are operated incorrectly or used for purposes other than those specified in the Instruction Manual.

Exclusion of Misuse



Non-conforming uses include, for example, using the equipment for something other than it was designed for, as well as operation without duly installed safety equipment. The risk rests exclusively with the end-user.

Conforming use of the machine includes compliance with the technical data, information, and regulations in all parts of the complete Instruction Material, as well as compliance with the maintenance regulations. All local safety and accident prevention regulations must also be observed.

Liability

The machine should only be operated when in perfect working order, with due regard for safety and the potential dangers, as well as in accordance with the Instruction Material. Faults and malfunctions capable of impairing safety should be remedied immediately. We cannot accept any liability for personal injury or property damage due to operator errors or non-compliance with the safety instructions contained in this booklet. The risk rests exclusively with the end-user.

The Instruction Material should always be kept near the machine so that it is accessible to all concerned.

The local, general, statutory, and other binding regulations on accident prevention and environmental protection must also be observed in addition to the Instruction Material. The operating staff must be instructed accordingly. This obligation also includes the handling of dangerous substances and the provision/use of personal protective equipment.

The Instruction Material should be supplemented by instructions, including supervisory and notification duties with due regard for special operational features, such as the organization of work, work sequences, the personnel deployed, etc.

The personnel's awareness of the dangers and compliance with the safety regulations should be checked at irregular intervals.

Choice and Qualification of Personnel

Ensure that work on the machine is only carried out by reliable persons who have been appropriately trained for such work - either within the company, by our field staff, or at our office - and who have not only been duly appointed and authorized but are also fully familiar with the local regulations. Work on the machine should only be carried out by skilled personnel, under the management and supervision of a duly qualified engineer.

This not only applies when the machine is used for production but also for special work associated with its operation (startup and maintenance), especially when it concerns work on the hydraulic or electrical systems, as well as on the software/serial bus system.

Training

Everyone working on or with the machine should be duly trained and informed with regard to the correct use of the safety equipment, the foreseeable dangers which may arise during the operation of the machine, and the safety precautions to be taken. In addition, the personnel should be instructed to check all safety mechanisms at regular intervals.

Responsibilities

Clearly define who is responsible for operating, setting up, servicing, and repairing the machine. Define the responsibilities of the machine operator and authorize him to refuse any instructions by third parties if they run contrary to the machine's safety. This applies in particular to the operators of machines linked to other equipment. Persons receiving training of any kind may only work on or with the machine under the constant supervision of an experienced operator. Note the minimum age limits permitted by law.

A Word to the Operator

The greatest danger inherent in our machines is that of fingers, hands, or loose clothing being drawn into a device by life, coasting or rotating tools or assemblies, or of being cut by sharp instruments or burned by hot elements.

ALWAYS BE CONSCIOUS OF THESE DANGERS!

Safety Equipment on the Machines



All machines are delivered with safety equipment, which shall not be removed or bypassed during operation.

The correct functioning of safety equipment on machines and systems should be checked every day and before every new shift starts, after maintenance and repair work, when starting up for the first time and when restarting (e.g., after prolonged shutdowns).

If safety equipment has to be dismantled for setting-up, maintenance, or repair work, such safety equipment shall be replaced and checked immediately upon completing the maintenance or repair work. All protective mechanisms shall be fitted and fully operational whenever the machine is at a standstill or if it has been shut down for a longer period of time.

Damage

If any changes capable of impairing safety are observed in the machine or its modes of operation, such as malfunctions, faults, or changes in the machine or tools, appropriate steps must be taken immediately, the machine switched off, and a proper lockout tag-out procedure followed. The machine should be examined for obvious damage and defects at least once per shift. Damage found shall be immediately remedied by a duly authorized person before resuming the operation of the machine.

The machine should only be operated when in perfect working order and when all protective mechanisms and safety equipment, such as detachable protective mechanisms, emergency STOP systems, etc., are in place and operational.

Faults or Errors

The machine must be switched off and all moving or rotating parts allowed to come to a standstill and secured against accidental restart before starting to remedy any faults or errors.

Signs on the Machine

Safety and danger signs on the machine should be observed and checked at regular intervals to ensure that they are complete and undamaged. They should be clearly visible and legible at all times.

Clothing, Jewelry, Protective Equipment

Long loose hair, loose-fitting clothes, gloves, and jewelry, including rings, should be avoided in order to avoid injuries due to being caught, drawn in, and wound up inside the machine.

Protective Eyewear

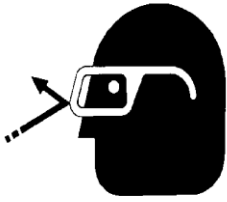

Protective eyewear that has been tested by the local authorities should be worn whenever there is a possibility of loose or flying objects or particles, such as when cleaning the machine with compressed air.

Tools

Always count the number of tools in your possession before starting work on the machine. This will allow you to check that no tools have been left behind inside the machine. Never leave a tool in the machine while working.

Oils, Lubricants, Chemicals

Note the applicable safety regulations for the product used.

No Smoking, Fire, Explosion Hazard

Smoking and open flame (e.g., welding work) should be prohibited in the production area due to the risk of fire and explosions.

Workplace

A clear working area without any obstructions whatsoever is essential for the safe operation of the machine. The floor should be level and clean, without any waste.

The workplace should be well lit, either by the general lighting or by local lights.

Emergency STOP

The emergency STOP buttons bring all machine movements to a standstill. Make sure you know exactly where they are located and how they work. Try them out. Always ensure easy access to the nearest emergency STOP button while working on the machine.

First Aid

1. Keep calm even when injured.
2. Clear the operator from the danger zone. The decision of what to do and whether to seek additional assistance rests entirely with you, particularly if someone has been trapped.
3. Give First Aid. Special courses are offered by such organizations as the employers' liability insurance association. Your colleagues should be able to rely on you and vice versa.
4. Call an ambulance. Do you know the telephone numbers for the ambulance service, police, and fire service?

Important Notices

Reporting and Fighting Fires

Read the instructions posted in the factory with regard to reporting fires and emergency exits. Make sure you know exactly where the fire extinguishers and sprinkler systems are located and how they are operated. Pass on the corresponding information to the firemen when they arrive. Ensure there are enough signs to avoid fire hazards.

The following fire extinguishers may be used:

- Dry powder extinguishers, ABC fire-extinguishing powder.
- Carbon dioxide fire extinguishers to DIN 14461 for electronic components. Great care must be exercised when using carbon dioxide fire extinguishers in confined, badly ventilated rooms (see DIN 14406 and 14270).

Isolate the machine from the power supply if a fire breaks out. Do not use water on burning electrical parts until it is absolutely certain that they have been completely disconnected from the power supply. Burning oils, lubricants, plastics, and coatings on the machine can give off gases and vapors that may be harmful to your health.

A qualified person should be consulted to repair the damage after a fire.

Electrical Power Supply



Before undertaking any maintenance or repair work on the machine, switch off the electrical power to the machine at the main source and secure it with a padlock so that it cannot be switched on again without authorization.

In practice, this may mean that the technician, electrician, and operator all attach their own padlock to the master switch simultaneously so that they can carry out their work safely. Locking extension plates should be available for multiple locks if required. The primary purpose of a lockout/tag-out procedure is to protect workers from injury caused by unexpected energizing or startup of equipment.

Energy sources (electrical/pneumatic/hydraulic, etc.) for the equipment shall be turned off or disconnected and the switches locked or labeled with a warning tag. It is the responsibility of the employer to establish control procedures. Follow lockout/tag-out procedures before, setup, and/or any service or maintenance work is performed, including lubrication, cleaning, or clearance of jams.

Caution: The machine is still not completely de-energized even when the master switch is off.

- Electricity - The machine is always isolated from the electrical power supply whenever the master switch has been switched off. However, this does not apply to the power supply in the control cabinet nor to equipment that does not draw its power via the master switch.

- Pneumatic / hydraulic energy - Almost all our machines carry compressed air. In addition to switching off the master switch, the air supply must also be disconnected and the machine-checked to ensure it is depressurized before starting any work on the machine; otherwise, the machine may execute uncontrolled movements.

- Kinetic energy - Note that some motors or spindles, for example, may continue to run or coast run on after being switched off.
- Potential energy - Individual assemblies may need to be secured if necessary for repair work.

Delivery of the Machine/Packaging

Note any markings on the packaging, such as weights, lifting points, and special information. Avoid temperature fluctuations. Condensation may damage the machine.

Transport Damage

The packaging and machine must immediately be examined for signs of damage in transit. Such damage must be reported to the shipper/transporter within the applicable time limits. Contact Atlanta Attachment Company and/or your transport insurer immediately if signs of damage are visible. Never operate a damaged machine.

Interim Storage

If the machine has to be stored temporarily, it must be oiled or greased and stored in a dry place where it is protected from the weather in order to avoid damage. A corrosion-inhibiting coating should be applied if the machine has to be stored for a longer period of time, and additional precautions should be taken to avoid corrosion.

Transporting the Machine

Disconnect the machine from all external connections and secure any loose assemblies or parts. Never step under a suspended load. When transporting the machine or assemblies in a crate, ensure that the ropes or arms of a forklift truck are positioned as close to the edge of the crate as possible. The center of gravity is not necessarily in the middle of the crate. Note the accident prevention regulations, safety instructions, and local regulations governing the transport of the machine and its assemblies.

Only use suitable transport vehicles, hoisting gear, and load suspension devices that are in perfect working order and of adequate carrying capacity. Transport should only be entrusted to duly qualified personnel.

Never allow the straps to rest against the machine enclosure and never push or pull sensitive parts of the machine. Ensure that the load is always properly secured. Before or immediately after loading the machine, secure it properly and affix corresponding warnings.

All transport guards and lifting devices must be removed before the machine is started up again. Any parts that are to be removed for transport must be carefully refitted and secured before the machine is started up again.

Workplace Environment

Our machines are designed for use in enclosed rooms: Permissible ambient temperature approx. 5 - 40 °C (40 - 104 °F). Malfunctions of the control systems and uncontrolled machine movements may occur at temperatures outside this range.

Protect against climatic influences, such as electrostatic charges, lightning strikes, hail, storm damage, high humidity, and salinity of the air in coastal regions.

Protect against influences from the surroundings: no structure-borne vibrations, no grinding dust, or chemical vapors.

Protect against unauthorized access.

Ensure that the machine and accessories are set up in a stable position.

Ensure easy access for operation and maintenance (Instruction Manual and layout diagram); also verify that the floor is strong enough to carry the weight of the machine.

Local Regulations

Particular attention must be paid to local and statutory regulations, etc., when installing machines and the plant (e.g., with regard to the specified escape routes). Note the safety zones in relation to adjacent machines.

Maintenance

General Safety Instructions

The machine shall be switched off, come to a standstill, and be secured so that it cannot be switched on again inadvertently before starting any maintenance work whatsoever. Use proper lockout/tag-out procedures to secure the machine against the inadvertent startup.

Remove any oil, grease, dirt, and waste from the machine, particularly from the connections and screws, when starting the maintenance and/or repair work. Do not use any corrosive cleaning agents. Use lint-free rags.

Retighten all screw connections that have to be loosened for the maintenance and repair work. Any safety mechanisms that have to be dismantled for setting-up, maintenance, or repair purposes must be refitted and checked immediately after completing the work.

Maintenance, Care, Adjustment

The activities and intervals specified in the Instruction Manual for carrying out adjustments, maintenance, and inspections must be observed, and parts replaced as specified.

All hydraulic and pneumatic lines should be examined for leaks, loose connections, rubbing, and damage whenever the machine is serviced. Any defects found must be remedied immediately.

Waste, Disassembly, Disposal

Waste products should be cleared from the machine as soon as possible so as not to create a fire hazard. Ensure that fuels and operating lubricants, as well as replacement parts, are disposed of in a safe and ecologically acceptable manner. Note the local regulations on pollution control.

When scrapping (disassembling) the machine and its assemblies, ensure that these materials are disposed of safely. Either commission a specialist company familiar with the local regulations or note the local regulations when disposing of these materials yourself. Materials should be sorted properly.

Repair

Replacement Parts

We cannot accept any liability whatsoever for damage due to the use of parts made by other manufacturers or due to unqualified repair or modification of the machine.

Repair, Electrical

The power supply must be switched off (master switch off) and secured so that it cannot be switched on again inadvertently before starting any work on live parts.

Those parts of the machine and plant on which inspection, maintenance, or repair work is to be carried out must be isolated from the power supply if specified. The isolated parts must first be checked to determine that they are truly de-energized before being grounded and short-circuited. Adjacent live parts must also be isolated.

The protective measures implemented (e.g., grounding resistance) must be tested before restarting the machine after all assembly or repair work on electric parts.

Signal generators (limit switches) and other electrical parts on the safety mechanisms must not be removed or bypassed. Only use original fuses or circuit overloads with the specified current rating. The machine must be switched off immediately if a fault develops in the electrical power supply.

The electrical equipment of our machines must be checked at regular intervals and any defects found must be remedied immediately.

If it is necessary to carry out work on live parts, a second person should be on hand to operate the emergency OFF switch or master switch with voltage release in the event of an emergency. The working area should be cordoned off and marked by a warning sign. Only use electrically insulated tools.

Ventilation/Hazardous Gases

It is the end users' responsibility to ensure adequate ventilation is provided to exhaust any and all noxious or hazardous gases that may be present in the working environment.

Hydraulic and Pneumatic Systems

Work on hydraulic or pneumatic equipment shall only be carried out by persons with training, knowledge, and experience of hydraulic systems. Pressure lines shall be depressurized before starting any repair work.

General Liability

Liability for machine damage and personal injury is extinguished completely if any unauthorized conversions or modifications are undertaken. The machine must not be modified, enlarged, or converted in any way capable of affecting safety without the manufacturer's prior approval.

Starting Machine Movements

Read the Instruction Manual carefully to establish which keys and functions start machine movements.

A Word to the End-User

The end-user has the sole responsibility to enforce the use of safety procedures and guards on the machine. Any other safety devices or procedures due to local regulations should be retrofitted in accordance with these regulations and/or the EC Directive on the safety of machines.

The operator's position must always be readily accessible. Escape routes must always be kept clear, and safety areas should be identified.

Safety Precautions

Safety should be a constant concern for everyone. Always be careful when working with this equipment. While normal safety precautions were taken in the design and manufacture of this equipment, there are some potential safety hazards.

Everyone involved with the operation and maintenance of this equipment should read and follow the instructions in this manual.

Operate the equipment only as stated in this manual. Incorrect use could cause damage to the equipment or personal injury.

It is the owner's responsibility to make sure that the operator reads and understands this manual before operating this equipment. It is also the owner's responsibility to make sure that the operator is a qualified and physically able individual, adequately trained in the operation of this equipment.

Specific safety warning decals are located on the equipment near the immediate areas of potential hazards. These decals should not be removed or obliterated. Replace them if they become non-readable.

- ALWAYS keep safety shields and covers in place, except for servicing.
- ALWAYS operate equipment in daylight or with adequate working lights.
- Follow daily and weekly checklists, making sure hoses are tightly secured, and bolts are tightened.
- ALWAYS watch and avoid holes or deep depressions.
- ALWAYS wear adequate eye protection when servicing the hydraulic system and battery.
- NEVER operate a poorly maintained machine.
- NEVER allow persons to operate this machine without proper instruction.
- NEVER put hands or feet under any part of the machine while it is running.
- NEVER attempt to make any adjustments or repairs to the machine while running. Repairs or maintenance should be performed by trained personnel only.
- NEVER work under the machine unless it is safely supported with stands, blocks, or a hoist and blocks.
- NEVER touch hot parts of the machine.

Installation

General Machine Data

Electrical 220 VAC, 10 A, 50/60 Hz 3 Phase
 Pneumatic 70 - 80 PSI, 7 SCFM avg.
 Ruffler Sewing Head Singer 300UX6
 Thread type D-69B 2 ply bonded nylon or similar
 Sewing Speed 3500 RPM
 Needle Schmetz 180/24, 62 x 59,
 Stitch Density 6-8 SPI

Flanger Sewing Head Yamato 1804P
 Thread Type D-69B 2 ply bonded nylon or similar
 Sewing Speed 3500 RPM
 Needle Schmetz UY113, 100/16
 Stitch Density 6-8 SPI

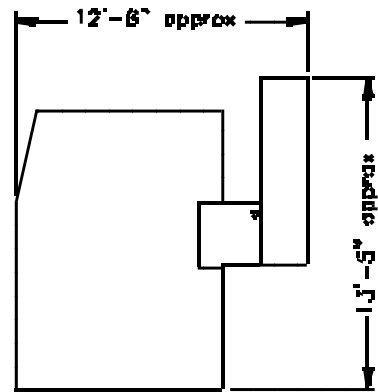

Physical Dimensions

Machine Height: 6 ft.
 Floor Area: 175 ft.²
 Weight: Approx. 1300 lbs.

Light Tower Functions

The purpose of the Light Tower is to provide a visual indication of the current status of the machine that can be seen at a considerable distance from the machine. Definitions for the different light states currently available on the 1335 are included below.



Light Status	Definition
Green Steady	Machine is making a panel.
Green Flashing	Machine is sewing the last side of the panel and will finish soon.
Yellow Steady	Machine is on but idling between panels.
Yellow Flashing	Machine is stopped in the middle of a panel and needs operator attention before continuing. Possibly the machine has stopped because of an error, thread break, etc. If the operator cannot recover, the mechanic must be called.
Red	Available for future use, not currently utilized

Operation

Control Panel

The Control Panel allows the operator to start and stop the automatic function of the machine and shut off power to the machine in the event of an emergency.

Caution: Unlocking the button with the Power "ON" engaged will turn on the power to the machine.

Emergency Stop

Pressing this Red button will turn off the power to the machine. This button will lock when pressed. Twisting the button will cause it to unlock and return to its normal position.

Power On

Pressing this green button will turn "ON" power to the machine. If the Emergency stop switch is activated, the machine will not turn on.

Touch Screen

It controls all machine functions. More details are available in related chapters in this manual.

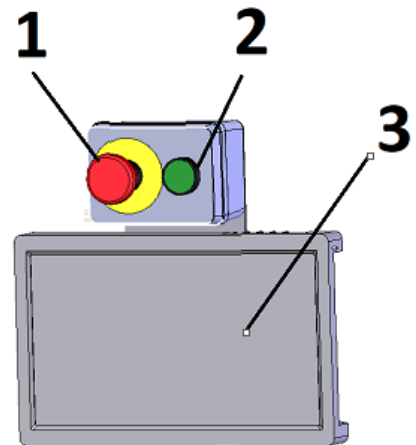

Power "ON"

Twist the Emergency Stop Red Button Clockwise "1" to return to its normal position. Turn the machine "ON" by pressing the green button "2" on the box just above the touch screen "3". The machine will first display the language choices, and after several seconds, it will show the "Operator" screen.

Caution: Do Not Use Any Sharp Objects to Touch the Screen

Loading the Gusset and Flange Material into the Flanger Module

Load the flange material onto the roll holder in front of and between the Flanger head. The material should unroll from the bottom left of the roll. Feed the fabric up through the tension plates, through the flange guide, and under the presser foot and puller. Check the alignment of the material to the needle and adjust the roll position and guides as necessary to keep the material straight. Use the Flanger manual Foot Lift pedal to raise the foot and puller.



Load the roll of gusset material onto the roll holder between the two discs so that when the material is fed toward the flanging head, the good side of the fabric is up. Be sure the drag tension tape is draped over the top of the roll, and the discs are loose against the roll core. Feed it into and through the Flange Guide and under the presser foot and puller roller. Use the Flanger manual Foot Lift pedal to raise the foot and puller. Refer to the diagram on page 115 for component identification and location.



Using the Flanger SEW pedal, sew about 10 feet of material through the flanger. Check the stitching margin and adjust the guides as necessary. There must be enough material to load the Ruffler folder and leave a loop in the flanger long enough to cover the loop control eye.

Loading and Adjusting the Folders

Feed the gusset up and over the right-angled guide roller, across and through the center guide rod, around the left-angled guide roller, and down into the Ruffler Folder.; load the material into and through the material guide, under the foot and puller. Adjust the left and right folder guides to set the position of the gusset to the stitch line. Adjust the left and right-angled guide rollers to help align the gusset with the folder.



Pull the gusset material through the folder, under the ruffler blade, and under the foot and puller. If the presser foot is not up, press the LOAD PANEL button or RESET. Make sure the ruffling assembly is pushed in and the home sensor made.

Adjusting the Active Edge Guiding

The active edge guide located under the cloth plate controls the position of the panel while sewing. The position of the panel left to right is determined by the electric eye that looks up through a slot in the cloth plate at the reflective tape on the bottom of the stripper blade. This eye is positioned by loosening the clamp handle and sliding the eye left or right. Adjust as necessary to align the edge of the panel to the edge of the gusset. Set the alignment guide to match the position of the edge guide to aid in loading the panel. It is usually necessary to readjust the Corner Stop Count whenever the stitching margin changes.



Starting the Automatic Cycle

With the gusset loaded and the folder all the way in, position the panel under the presser foot in the middle of a short side and align with the alignment guide.

After pressing the START button, the automatic cycle will begin. The presser foot will drop, and sewing will begin. At the same time, the trap door will rise and fill in the opening in front of the sewing

head. The operator must step aside to allow the trap door to move. Keep hands, etc., clear of the trap door while it is moving. The machine will sew all four sides of the panel, ruffling the corners, and stop for cutting. Use the wipe switch to raise the folder and cut the gusset, then swing the ruffling assembly to the right and out of the way.

Finishing the Panel

Fold the trailing edge of the gusset under itself and fold the leading edge up into the trailing edge fold and lay it on top of the starting edge of the gusset. Continue to sew across the folded gusset until you overlap the starting stitches. Tap the foot lift pedal to raise the presser foot and remove the panel. Position the edge of the gusset back under the foot and over-sew the stitch line for the flange margin. Remove the panel and press the LOAD PANEL button.

Ruffler Setting

The ruffler settings are found on the styles setting page in each style.

Setting Page 1

The corner stop count, ruffler rotated time, ruffler per corner, stitches per ruffler, and the ruffler type (round or square) can be set per each style. The style setting also has the panel size and the stitch per inch for seam sewing.

Setting page 2

Controls the air table Soffie jets to help move the panel as it is sewn.

Setting page 3

Controls the air table blower to control the panel float.

Ruffle Size Adjustments

To adjust the size of the ruffle, turn the adjustment knob located on the front of the ruffler assembly.

Turning the knob clockwise makes the ruffler smaller; turning the knob counterclockwise will make the ruffle larger.

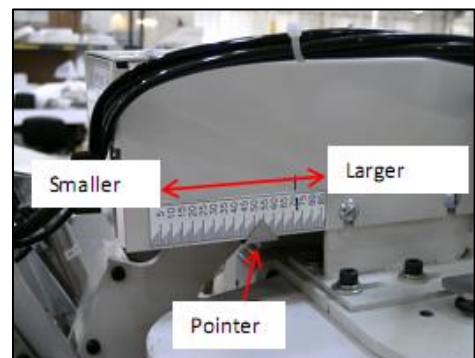
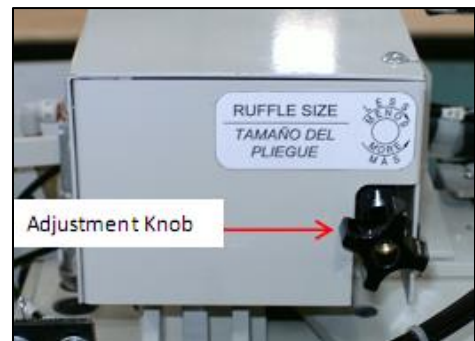

There is a scale located on the side of the right side of the ruffler assembly. The pointer will move as the knob is turned; the smaller the number, the smaller the ruffle, the larger the number, the larger the ruffle.

Sizing the Panel

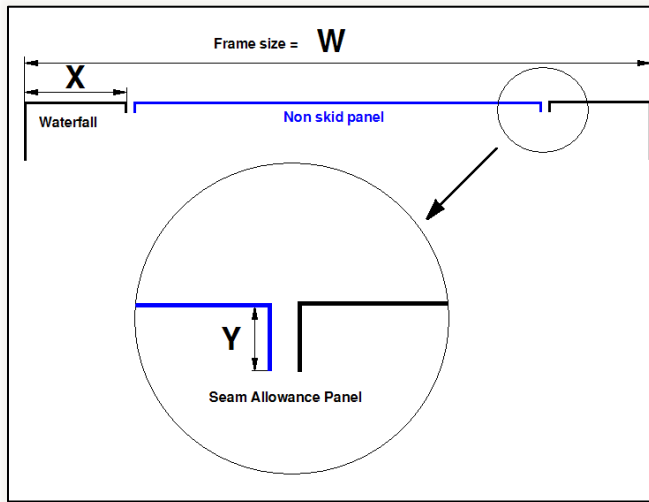

Panel size:

$$W - (2 \times X) + (2 \times Y)$$

Example:

Frame size = 80"

Waterfall = 3"

Seam allowance panel = 1/2."

Panel size = $80'' - (2 \times 3'') + (2 \times 1/2'')$

Panel size = $80'' - 6'' + 1''$

Panel size = 75"

Service

General Machine Adjustments

Air Pressure

Set all air supply pressure regulators:

Main	80 PSI
Sewing Blowers	40 PSI
Turning Blowers	40 PSI
Turning Clamps	10 PSI
Edge Guide	30 PSI



Set the Low Air Pressure switch to trip at 60 PSI.

Soffie Jets

Set the Soffie jets in the air table so that they blow in the directions noted on the 1335A-PD2 Pneumatic Diagram. Set the flow controls on the jets to be all the way open.

Set all flow controls for smooth, quiet motions of all cylinders. Set all cylinder limit switches at the ends of strokes.

Electric Eye Sensor Adjustment

To adjust the sensor, first, remove the clear plastic cover from the end of the sensor. There are two adjusting screws under the cover. One is labeled "GAIN" and is used to set the sensitivity of the sensor. The other screw is labeled "DO & LO" and should always be fully clockwise.

With the end of the sensor pointing at the center of the reflective tape, turn the "GAIN" screw counterclockwise until the red LED indicator is off. Then turn the "GAIN" screw clockwise until the LED indicator comes on. Then turn the "GAIN" screw one full turn clockwise. The LED indicator should be blinking slowly. Cover the eye so that the sensor cannot see the reflective tape, and the LED should go off.

Reflective Tape Maintenance

- Use a soft cloth for cleaning.
- Do not use chemicals or abrasives to clean it.
- Avoid any contact with oils and liquids.
- Do not touch the tape with bare fingers.
- If the tape is dirty or opaque, the eye may not function correctly.

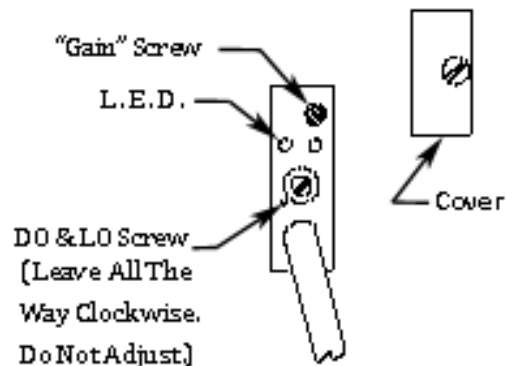

Electrical

NOTE: All maintenance should be performed by a qualified service technician.

ATTENTION. Make sure that the machine is unplugged before proceeding and that all lockout/tag-out procedures have been correctly followed (See to Lockout tag out procedure)

Ground

This unit needs to be connected to the ground (earth) for several reasons. In main powered equipment, exposed metal parts are connected to the ground to prevent user contact with dangerous voltage when electrical insulation fails. In electrical power distribution systems, a protective ground conductor is an essential part of the safety Earthlink system. Connection to the ground also limits the buildup of static electricity.



Touch Screen

This machine uses a 12 VDC touch screen Monitor 1920 x 1080 Full HD. It is connected to the computer through an HDMI cable.

1. USB Cable: For touch function. It's connected to the computer.
2. HDMI: Video signal and audio input. It is connected to the computer.
3. EAR: 3.5 mm headphones audio output.
4. VGA: Video signal input.
5. LINE IN: Audio signal input when connected VGA.
6. DC 12V: DC 12V power port. Connected to the PS2 power supply. (12V)



1. Light Red, 'Blue light. Indicates power status.
2. Turn on/off the monitor when it is powered.
3. + By default. The key is the hotkey for volume. When in the OSD menu, press for up/increase adjustment.
4. - By default. The key is the hotkey for volume. When in the OSD menu, press for down/decrease adjustment.
5. MENU Press to display the setting OSD menu. When in the OSD menu, press to confirm the selection.
6. When in the OSD menu. Press to exit the OSO menu.



Stepper Control Box



Set the stepper control boxes thumbwheels and jog speeds initial settings:

Refer to the 1335-905 Stepper Box Adjustments and set the direction and motor current jumpers for each box.

Set the top left box (Puller) to "260" on the thumbwheels. AP-28-800C3 set to 230

Set the top right (Conveyor) to "275" on the thumbwheels. AP-28-800GG

Set the top right (Edge Guide) jog pot for 40 RPM at the edge guide wheel.

Set the bottom left (Ruffler) to "108" on the thumbwheels. AP-28-800Y1A

Set the bottom right (Rotator) jog knob to "40" on the dial. AP-28-800D

(Remove cover for access.)

Refer to the speed control manual for programming instructions.

The stepping motor boxes are located under the rear table.

The Ruffler box has three thumbwheels on the front, which are set to synchronize the ruffler to the sewing head. The number is proportional to the stitch length and is not affected by sewing speed. The 10-turn potentiometer is used to set the speed of the ruffler feed out to make the next ruffle. If the ruffler blade stalls while feeding in or out, you will need to lower the setting on this thumbwheel. To adjust, unlock the dial and turn counterclockwise to reduce the speed, and turn clockwise to increase.

The back of the box has an on/off switch, fuse, and cables. Leave the on/off switch on all the time. When working on the box, always disconnect the power cord before servicing.

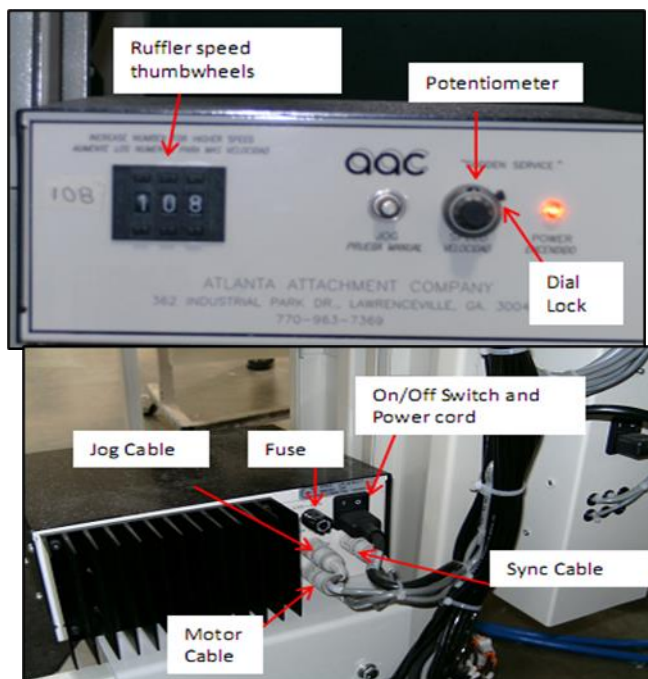

Stepper Control Box AP-28-800Y1

The Ruffler box is located under the table and has three Thumbwheels "A" on the front, which are set to synchronize the ruffler to the sewing head. The number is proportional to the stitch LENGTH and is not affected by sewing speed. **Original factory setting 108**



The thumbwheels control the speed of the ruffler as it feeds in material synchronous with the ruffler sewing head. Adjust the speed so that the stitch length is the same as when sewing the long seam. The potentiometer controls the speed of the ruffler as it rotates to the home position.

2.- Mini Switch (SW1)

- **Switch # 1:** Control the rotations of the motor CW: Clockwise rotation. CCW: Counter close wise rotation For 1335 Ruffler 2 AMPS motors set to position Open (CW)
- **Switch 2:** No function
- **Switch 3:** No function
- **Switch 4:** For 1 amps motors. For 1335 Ruffler 2 AMPS motors set to position Open
- **Switch 5:** For 2 Amps Motors. For 1335 Ruffler 2 AMPS motors set to position Close
- **Switch 6:** For 2.5 Amps Motors. For 1335 Ruffler 2 AMPS motors set to position Open
- **Switch 7:** For 3 Amps Motors. For 1335 Ruffler 2 AMPS motors set to position Open
- **Switch 8:** For 3.5 Amps Motors. For 1335 Ruffler 2 AMPS motors set to position Open

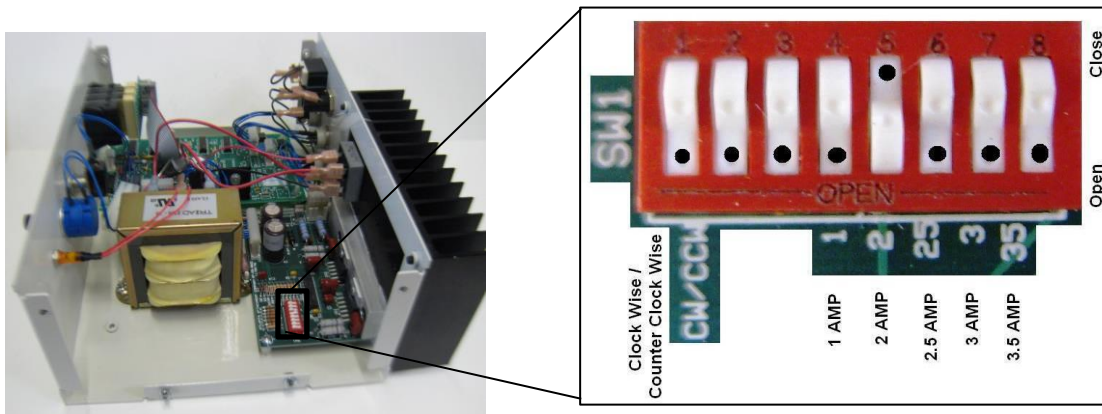

Control Screens

Main Ready Screen

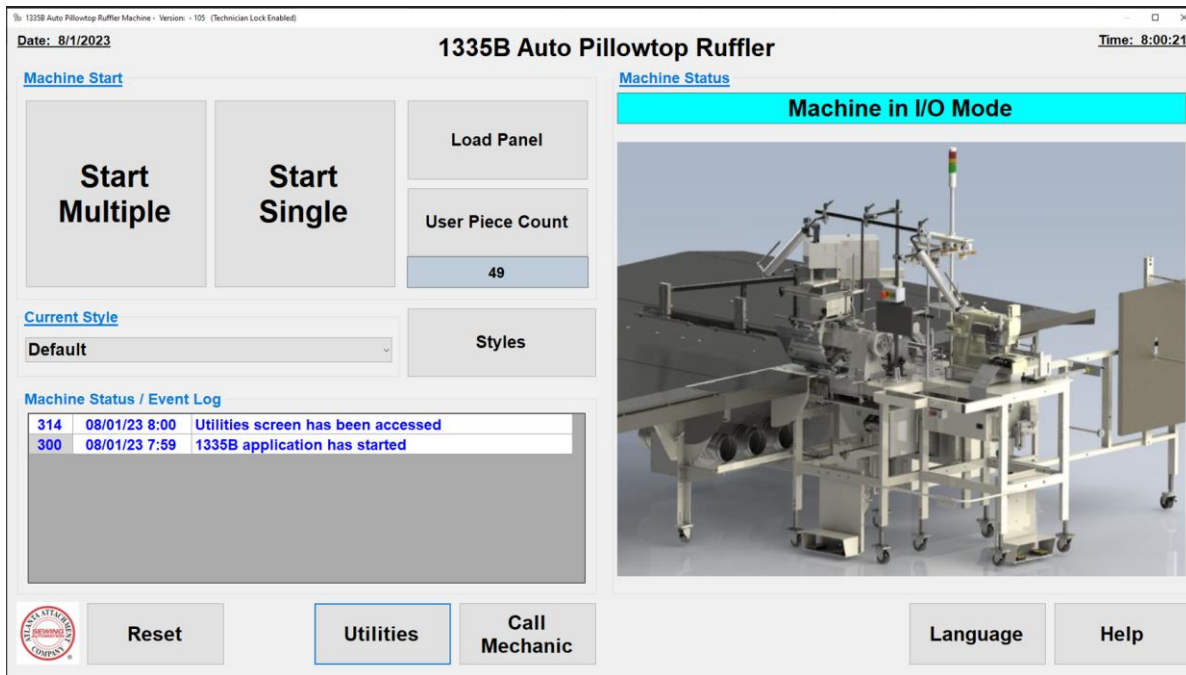

Security

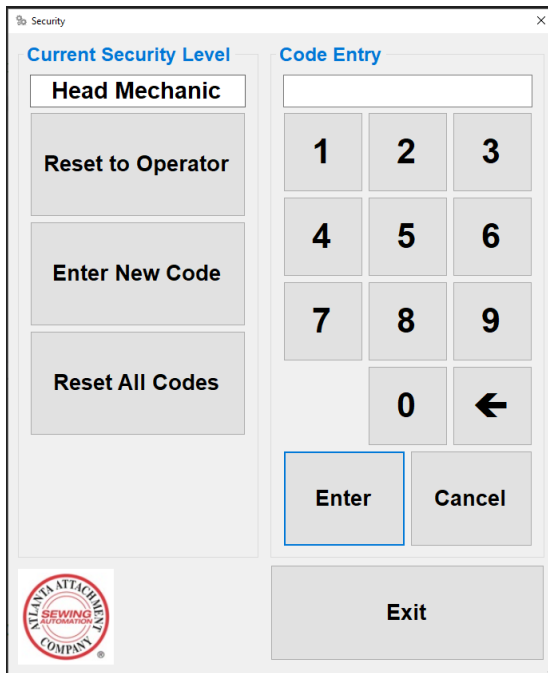

Language

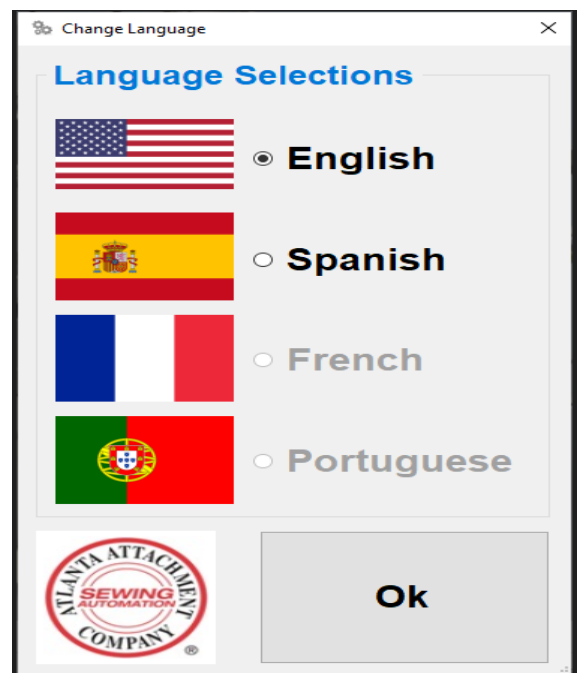

Message Mechanic or Supervisor

E-mail Mechanic or Supervisor. etc

Alarm Screen

Timestamp	Alarm	Description
7/29/2020 12:51 PM	906	Edge Guide Alarm
7/28/2020 3:42 PM	906	Edge Guide Alarm
7/28/2020 2:36 PM	906	Edge Guide Alarm
7/28/2020 2:35 PM	906	Edge Guide Alarm
7/28/2020 2:10 PM	906	Edge Guide Alarm
7/28/2020 2:09 PM	906	Edge Guide Alarm
7/28/2020 2:09 PM	906	Edge Guide Alarm
7/28/2020 2:09 PM	906	Edge Guide Alarm
7/28/2020 1:25 PM	906	Edge Guide Alarm
7/28/2020 1:25 PM	906	Edge Guide Alarm
7/28/2020 1:25 PM	906	Edge Guide Alarm
7/24/2020 11:27 AM	906	Edge Guide Alarm
7/24/2020 11:18 AM	906	Edge Guide Alarm
7/24/2020 10:51 AM	906	Edge Guide Alarm
7/24/2020 10:51 AM	906	Edge Guide Alarm
7/24/2020 10:40 AM	906	Edge Guide Alarm
7/24/2020 10:08 AM	906	Edge Guide Alarm
7/24/2020 10:07 AM	906	Edge Guide Alarm
7/24/2020 9:34 AM	906	Edge Guide Alarm
7/24/2020 9:34 AM	906	Edge Guide Alarm
7/24/2020 9:22 AM	906	Edge Guide Alarm
7/24/2020 9:21 AM	906	Edge Guide Alarm
7/24/2020 9:18 AM	906	Edge Guide Alarm

Efficiency of Shift Operations

Efficiency for Entire Shift

Select Shift

08/01/2023

1st Shift
 2nd Shift
 3rd Shift

Apply

Efficiency

Run Time / Shift Time = Efficiency

Shift Time / Units = Per Units

Estimated Units for Shift

Exit



Shift Settings

Shift Settings

Shift Settings (24 Hour)

Shift 1 - Start 06:00 Shift 2 - Start 18:00 Shift 3 - Start 00:00

Shift 1 - End 18:00 Shift 2 - End 04:00 Shift 3 - End 00:00

Save Times **Exit**



Product History

Product History

Total Count = 45

Style	Timestamp	Run Time	Length	Width	Barcode
Default	10/23/2020 10:09 AM	0	76.00	39.50	
Default	10/23/2020 8:11 AM	0	76.00	39.50	
Default	10/21/2020 4:32 PM	0	76.00	39.50	
Default	10/13/2020 8:36 AM	0	76.00	39.50	
Default	10/12/2020 4:30 PM	0	76.00	39.50	
Default	10/12/2020 4:27 PM	0	76.00	39.50	
Default	10/12/2020 4:26 PM	0	76.00	39.50	
Default	10/12/2020 4:25 PM	0	76.00	39.50	
Default	10/12/2020 4:24 PM	0	76.00	39.50	
Default	10/12/2020 4:23 PM	0	76.00	39.50	
Default	10/12/2020 4:23 PM	0	76.00	39.50	
Default	10/12/2020 4:22 PM	0	76.00	39.50	
Default	10/12/2020 4:22 PM	0	76.00	39.50	
Default	10/12/2020 4:21 PM	0	76.00	39.50	
Default	10/12/2020 3:19 PM	0	76.00	39.50	
Default	10/12/2020 9:34 AM	0	76.00	39.50	
Default	10/12/2020 9:34 AM	0	76.00	39.50	
Default	10/12/2020 9:33 AM	0	76.00	39.50	
Default	10/12/2020 9:32 AM	0	76.00	39.50	
Default	10/12/2020 9:32 AM	0	76.00	39.50	
Default	10/12/2020 9:32 AM	0	76.00	39.50	
Default	10/12/2020 9:31 AM	0	76.00	39.50	
Default	10/12/2020 9:30 AM	0	76.00	39.50	

Default Reports Exit

Revision History

Revision History

Revisions for 1335B Auto Pillowtop Ruffler Machine

Version 105 - 08/19/2022
 Added Needle Safe functionality
 PLC Program = AA 1335B_104_V16.zap16

Version 104 - 06/30/2022
 Corrected issue loading and listing styles
 PLC Program = AA 1335B_101_V16.zap16

Version 103 - 02/01/2022
 Changed function of Pause button after Load Panel is pressed
 PLC Program = AA 1335B_101_V16.zap16

Version 102 - 04/27/2021
 Reworked tags to match an updated PLC program
 PLC Program = AA 1335B_101_V16.zap16

Version 101 - 12/04/2020
 Removed Input/Output button from Alarm screen
 Corrected Rotate Arm homing sequence
 PLC Program = AA 1335B_101_V16.zap16

Version 100 - 08/19/2020
 PLC Program = AA 1335B_100_V16.zap16

 Exit

Utilites

The screenshot shows the 'Machine Utilities' application window. It features a grid of buttons for various settings: Settings, Security, Product History, Email Setup, Input / Output, Revisions, Alarm History, Shift Setup, Manual Ruffle Cycle, Styles, Needle Safe, and Close Application. Below this grid is an 'Efficiency' section with input fields for Shift Time (121), Unit (0), Per Unit (0), Estimated Units for Shift (NA), User Count (0), Total Run Hours (0.00), and Total On Hours (0.50). There are also buttons for History, User Count Reset, and Exit. A logo for 'ALIANA ATTACHEMENT SEWING PERFORMANCE COMPANY' is visible in the bottom left corner.

Manual Ruffle Cycle Screen

The screenshot shows the 'Manual Ruffle Cycle' screen. It contains a text box with the instruction: "Step on the Sew Pedal to start the ruffling process and release the pedal to halt it at any time." Below the text box are two buttons: 'Reset' and 'Abort Ruffle'.

Manual 1 Screen

Manual Inputs and Outputs

Manual 1 | Manual 2 | Manual 3 | Manual 4

Ruffler Sew Head Low Speed <<< >>>	Edge Guide Eye Uncovered	Folder Lift Touch Switch Closed	Jam Detect Eye Covered	Ruffler Sew Head Needle Up Signal Off
Ruffler Sew Head High Speed <<< >>>	Edge Guide Lift	Folder Arm Lift	Sew Jet Eye Covered	Ruffler Sew Head Footlift Signal Off
Ruffler Sew Head Thread Detector Needle No Rotation	Edge Guide Forward <<< >>>	Conveyor Lift	Panel Trailing Edge Eye Covered	Ruffler Sew Head Motor Run Signal Off
Ruffler Sew Head Thread Detector Looper No Rotation	Edge Guide Reverse <<< >>>	Conveyor Jog <<< >>>	Gusset End Sensor Move	Air Pressure 0



Reset

Manual 2 Screen

Manual Inputs and Outputs

Manual 1 | Manual 2 | Manual 3 | Manual 4

Ruffler In Position Sensor Off	Ruffler Blade	Ruffler Enable	Ruffler Foot Lift Pedal Open	Soffie Jet Air Regulator Pressure Select 0
Ruffler Home Switch Open	Ruffler Foot Lift	Ruffler Forward <<< >>>	Ruffler Sew Pedal Open	Blower Speed Select 0
Ruffler In Switch Open	Ruffler Puller Lift	Ruffler Reverse <<< >>>		Trap Door
Stepper Box Power	Stripper Blade			

Reset

Manual 3 Screen

The screenshot shows the 'Manual 3' screen with the following components:

- Manual 1:** Flanger Sew Head Thread Detector Needle (No Rotation), Flanger Sew Head Thread Detector Looper (No Rotation), Gusset Material Eye (Covered), Flange Material Eye (Covered).
- Manual 2:** Flanger Foot Lift Pedal (Open), Flanger Foot Lift (Grey), Flanger Sew Pedal (Open), Flanger Sew Clutch <<< >>> (Grey).
- Manual 3:** Flanger Slack Eye (Covered), End Sew Eye (Covered).
- Manual 4:** Red Light, Yellow Light, Green Light.
- Reset Button:** Located at the bottom right.
- Logo:** ALUVA ATTACHEM SEWING AUTOMATION COMPANY.

Manual 4 Screen

The screenshot shows the 'Manual 4' screen with the following components:

- Manual 1:** Rotate Home Sensor (Open), Rotate Out Sensor (Open).
- Manual 2:** Rotate Enable (Grey), Rotate Forward <<< >>> (Grey), Rotate Reverse <<< >>> (Grey).
- Manual 3:** Front Clamp Up Sensor (Open), Front Clamp (Grey), Rear Clamp Eye (Covered).
- Manual 4:** Finger Clamp (Grey), Rear Clamp (Grey).
- Reset Button:** Located at the bottom right.
- Logo:** ALUVA ATTACHEM SEWING AUTOMATION COMPANY.

Styles 1 Screen

Panel Styles

Style Name
 Default Add New Style

Style Settings
 Settings 1 | Settings 2 | Settings 3

Panel Length	Panel Width	Stitches Per Inch	Corner Stop Stitch Count	Ruffle Rotate Time
80	60	5	5	.75
Ruffles per Corner	Stitches Per Ruffle	Corner Type	Square Corner Stitches - Side 1	Square Corner Stitches - Side 2
4	4	Rounded	4	4

Style Notes

 Load Style to Machine Save Style Delete Style Exit

Styles 2 Screen

Panel Styles

Style Name
 Default Add New Style

Style Settings
 Settings 1 | Settings 2 | Settings 3

Soffie Jet Air Regulator - Side 1	Soffie Jet Air Regulator - Side 2	Soffie Jet Air Regulator - Side 3	Soffie Jet Air Regulator - Side 4	Soffie Jet Air Regulator - Side 5
1	3	5	5	7
Soffie Jet Air Regulator - Turning	Last Ruffle Stitches			Barcode Number
6	5			

Style Notes

 Load Style to Machine Save Style Delete Style Exit

Styles 3 Screen

Panel Styles

Style Name

Default Add New Style

Style Settings

Settings 1 | Settings 2 | **Settings 3**

Blower Side 1 Speed Select	Blower Side 2 Speed Select	Blower Side 3 Speed Select	Blower Side 4 Speed Select	Blower Side 5 Speed Select
2	3	4	5	6

Style Notes



Load Style to Machine

Save Style

Delete Style

Exit

Settings 1

Machine Settings

Settings 1

Air Pressure Lower Limit	Flange/Gusset Splice Distance	End Sew Gap	End Sew Stop Count	Edge Guide Jam Detect Time
60	190.25	40	10	1.5
Conveyor Down Delay	Clamps Up Delay	Sew Head Jam Detect Time	Ruffler Needle Thread Detector Delay	Ruffler Looper Thread Detector Delay
1.5	1.0	1.5	1.5	1.5
Pre-Flange Stop Delay	Pre-Flange Thread Detector Enable	Slack Loop Timeout	Pre-Flange Needle Thread Detector Delay	Pre-Flange Looper Thread Detector Delay
1.5	Enabled	10	1.5	1.5



Exit

Sewing Head and Motor

Program the PANASONIC Sewing motor parameters as follows:
(Refer to the programming instructions on page 31)

XXXX

Set the correct rotation direction.
Set the needle up switch to stop the head needle up.
Set the sewing stitch length to 6 SPI.

Ruffler Drive Assembly

Set the Ruffler blade position left to right. The slot in the Ruffler blade should align with the sewing needle. Loosen the 4 Screws and adjust the Ruffler blade. The height of the ruffler blade is set at the ruffler blade left cylinder mount bracket.

Set the Ruffler blade IN position so that the Ruffler blade extends 1/8" past the needle when the needle is at the bottom dead center.

CAUTION - the Ruffler cylinder is powerful; keep hands, etc., away from the Ruffler blade when it is moving by stepping motor.

Edge Guide Assembly

Adjust the edge guide so that the wheel is centered in and out on the cutout in the cloth plate and in contact with the bottom of the folder when it is in its up position. Check for proper belt tension when the wheel is up. Be sure the lift cylinder does not bottom out when the wheel is in the up position against the bottom of the folder. Adjust the flow controls for smooth, quiet operation.

Adjust the edge guide eye to be looking up through the cutout in the cloth plate and at the same place left to right as the right edge of the material guide. Be sure there is reflective tape on the bottom of the stripper blade for the eye to see. There should be another 1/4" of adjustment left and right in the adjusting screw from this position. The guide wheel should be set to rotate at 80 RPM.

Rotator Assembly

Adjust the Rotator so that the center of rotation is located 3/4" to the left of the needle and even with the needle at the bottom dead center. The Rotator shaft must be perpendicular to the cloth plate. Adjust the pillow block bearings as necessary.

The Rotate Arm should be set for 2-1/2" clearance above the cloth plate.

Set the limit sensors and shock absorbers for 90 degrees of rotation with the Rotate Arm parallel to the edge of the air table in its rear position.

CAUTION: When rotating the arm by hand, be sure to unplug the stepper motor to prevent damage to the motor drive unit.

Set the panel clamps to just barely touch the tabletops when they are in their down position.

The finger clamp pressure plate should be set flush with the bottom of the other clamps. Set the rotary actuator for 90 degrees of rotation.

The Sew Head Jam Detector Eye should be looking at reflective tape placed right behind the puller and between the conveyor and the edge guide plate.

The Trailing Edge Eye should be looking at a piece of reflective tape located on the left side of the cloth plate.

Adjust the Blower Tube flow control, so the panel stays flat on the cloth plate while rotating.

Adjust the Soffie jet eye on top of the Ruffler cover to be looking at a 2 inches square piece of reflective tape located even with the needle and 30" from the edge of the air table nearest the sewing machine.

Adjust the rear clamp eye to be looking at a 2 inches square piece of reflecting tape located on the table side of the rear clamp. The eye activates the clamp during the cycle if it is covered by the pane.

Puller Assembly

Set the puller down position as low as practical without actually touching the cloth plate. The rollers should be centered on the needle.

Rear Conveyor Assembly

Set the conveyor, so it is level, parallel to the edge of the air table, and in line with the right puller roller.

Set the height stop to hold the conveyor 1/32" above the cloth plate.

Set the spring adjustments to make the conveyor press down with about 1-2 lbs. of weight.

1334 Auto Flanging Unit

The 1334 Auto Flanging Unit is an optional piece of equipment that attaches to the 1335 unit. The Auto flanger sews the flange and gusset materials together before it is sewn to the pillowtop panel by the 1335 unit.

Sequence of Operation

Press the Start (either SINGLE or MULTIPLE) buttons on the touch screen.

When the Pre-flanger Slack Eye is uncovered, the material will advance through the Pre-flanger sewing head, and a slack loop will accumulate until the Slack Eye is covered. The Pre-flanger will continue to sew for the time set in counter #20, Pre-flanger Stop Delay.

If the eye remains covered, the Pre-flanger stops and waits until the Slack Eye is uncovered again. The Pre-flanger can be operated independently by its Manual Sew and Foot-lift Pedals.

11335BS88CP Recommended Spare Parts List

Contact AAC's sales department to order replacement parts.

Phone: 770-963-7369
Fax: 770-963-7641
Email: sales@atlatt.com
Website: www.atlatt.com

Maintenance

Daily

Clean machine at the end of every shift

Clean lint etc. from the Looper area on the sewing head

Remove any threads wrapped around moving parts of the puller, conveyor, and accumulator rollers.

Wipe all photo-eye lenses with a clean, non-abrasive, dry cloth.

Use a blow-off hose to get rid of excess lint, thread, and other clippings.

Properly maintain the Singer sewing head - follow Singer recommendations and guidelines for daily maintenance and lubricating of the head.

Weekly

Check all belts for tightness and condition. Adjust or replace as necessary.

Check and clean the screens on the blower box.

Check blower v-belt tension and pulleys.

Check for excess play in the rotate arm assembly.

Put one drop of machine oil on all moving Ruffler parts.

Cleaning Electric Eyes and Sensors

The following illustrations show the names and locations of the electronic eyes and sensors on the 1335 unit. All of these eyes and sensors should be cleaned regularly or after each shift. The Edge Guide Eye should be cleaned even more often. Check the Edge Guide Eye hourly for lint buildup. Clean if necessary. Clean the eyes with a clean, soft cloth.

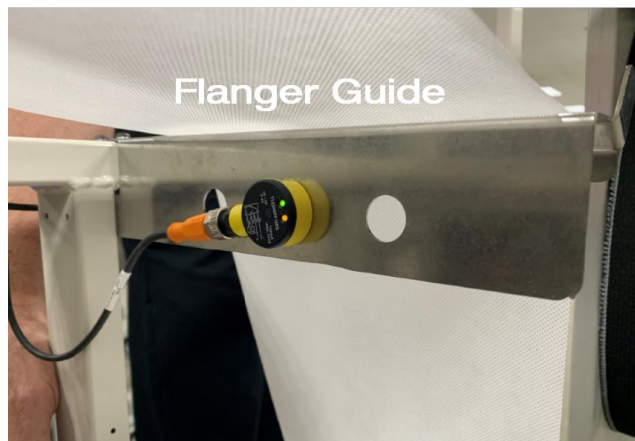

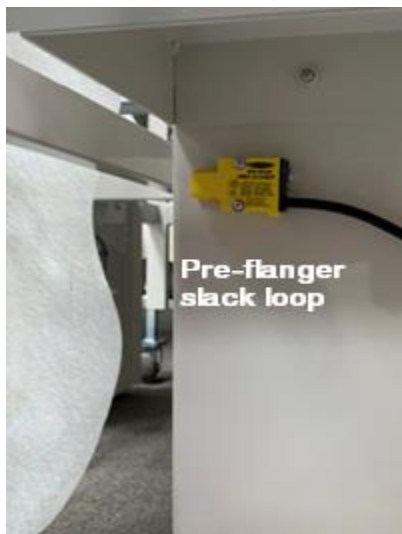
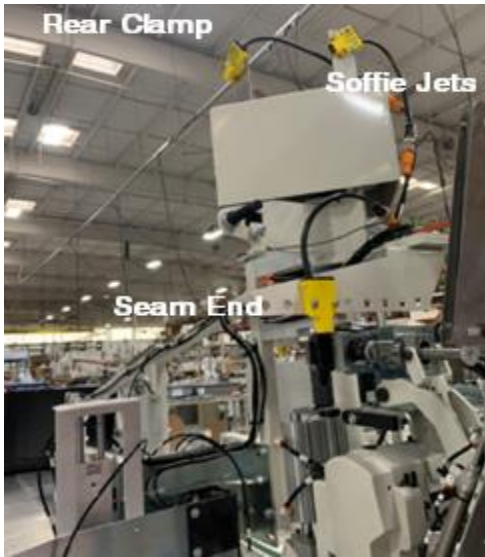

Programming Sequence for EFKA Motor

******1335BS88CP Parameter settings ******

Use Programming code "5913" to change the following set of parameters

PARAMETER	RANGE	VALUE	DESCRIPTION
290		5	Mode of operation. MUST SET THIS PARAMETER FIRST!!!
026		1	Treadle config for EB301
110	70-0390	390	Minimum Speed (positioning speed)
111	0-999	2500	Maximum speed when "129" is 0, 1, or 2
153	0-50	35	Braking power at machine standstill
161	0-1	1-CCW	Motor rotation (0 = CW, 1= CCW)
180	0-360 (175)	--	Degrees of reverse rotation to get to needle up
181	0-999 (10)	--	Delay until reverse rotation starts after trim
182	0-1 (0)	0	Enable reverse rotation after trim to move to "true" needle up
202	0-500	500	Sew delay after foot lift off
219	1-55	35	Breaking power at stop
250	0-359	--	Thread trimmer activation angle
270	0-6	1	External Handwheel Sensor Configuration (Position 2)
271	0-255	215	Ref. angle for Position 1 (Trim) from Position 2
272	0015-9999	1000	Drive ratio between motor pulley and handwheel pulley. If handwheel pulley is smaller than motor pulley, increase this value to slow down sewing head until measured speed matches speed set with parameter 111.
362	0-1	1	Position sensor voltage: 0 = 5V, 1 = 15V
436	0-1	0	Use code "5913". This disables an input that was causing box to reset itself.
401	0-1	1	Immediate save of parameters. MUST BE DONE LAST!!!

Front panel LED's:

Programming Instructions:

- | | |
|---------------------------------|------------------------------------------------------------------|
| LED 1: Off | 1. Power on holding down the "P" button till "COD" is displayed. |
| LED 2: Off | 2. Press ">>" once and enter the number "5913" |
| LED 3: Off | 3. Press "E" once and "4.0.0." is displayed this is a parameter |
| LED 4: Off | 4. Proceed to the parameter to be changed and press "E" |
| LED 5: Off | 5. The value now shows in the screen, adjust to desired value. |
| LED 6: Off | 6. Press "E" to enter value and continue with parameter setting. |
| LED 7: Off, Stop at needle down | 7. Repeat for other parameters, press "P" once when complete. |
| LED 8: On, Stop at needle up | 8. Run sewing head to save parameters before powering down |

******Perform a Master Reset of Parameters (See Below)******

To Perform Master Reset of Parameters:

1. Power on holding down the "P" button till "COD" is displayed.
2. Press ">>" once and enter the number "5913"
3. Press "E" twice and "093" is displayed.
4. Press "+" once, "094" is displayed.
5. Press "P" to exit programming mode with all default values.

Assembly Drawings & Parts Lists

The materials contained herein are the confidential and proprietary information of Atlanta Attachment Company. In addition to any confidentiality and non-disclosure obligations that currently exist between you and Atlanta Attachment Company, your use of these materials serves as an acknowledgment of the confidential and proprietary nature of these materials and your duty not to make any unauthorized use or disclosure of these materials.



One-Stop Shopping
For Expendable Replacement Parts for AAC & Other Bedding Equipment Suppliers
Toll Free: **1-866-885-5100**
www.atlantapartsdepot.com • sales@atlantapartsdepot.com

11335BS88CP Auto Pillowtop Ruffler PLC

AAC Drawing Number 9009048 Rev1

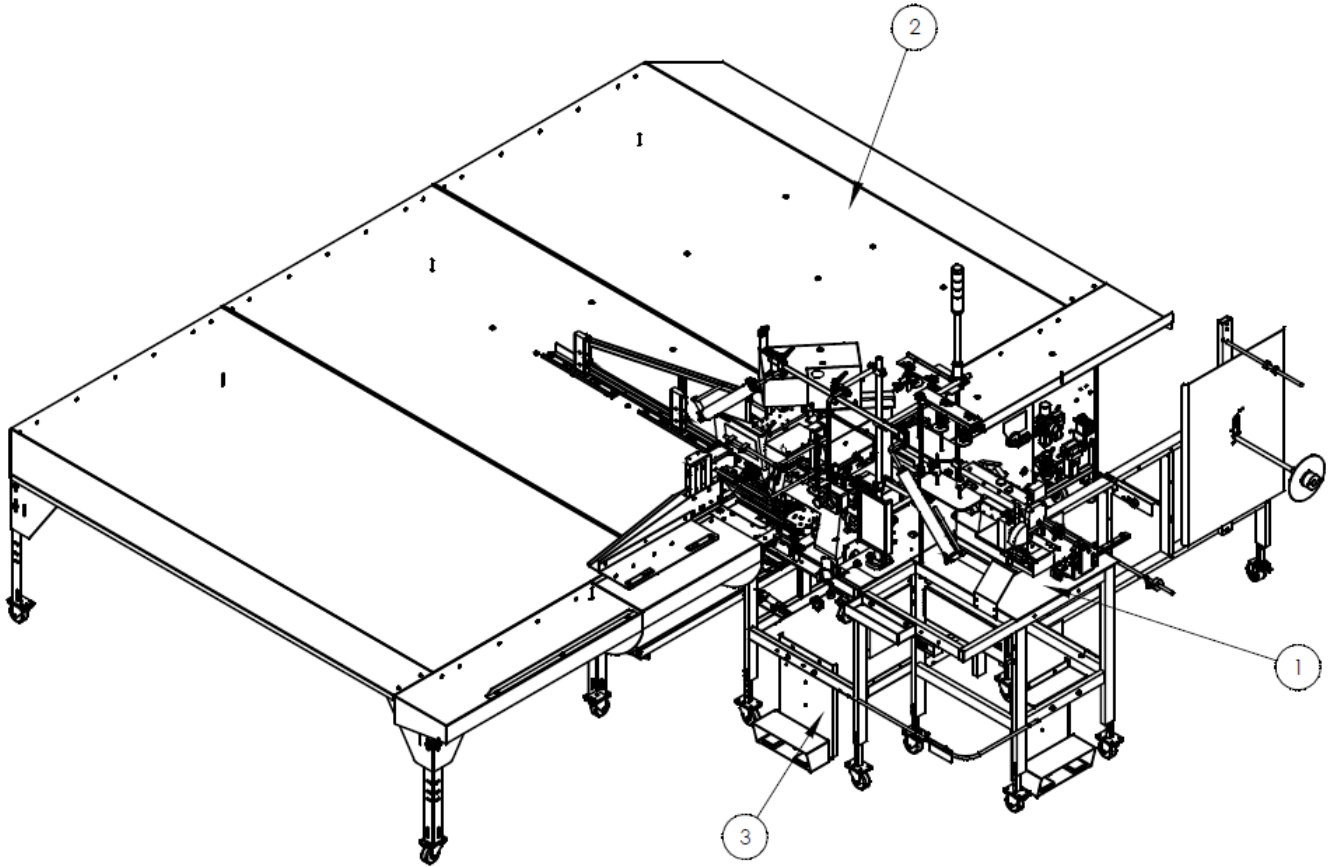





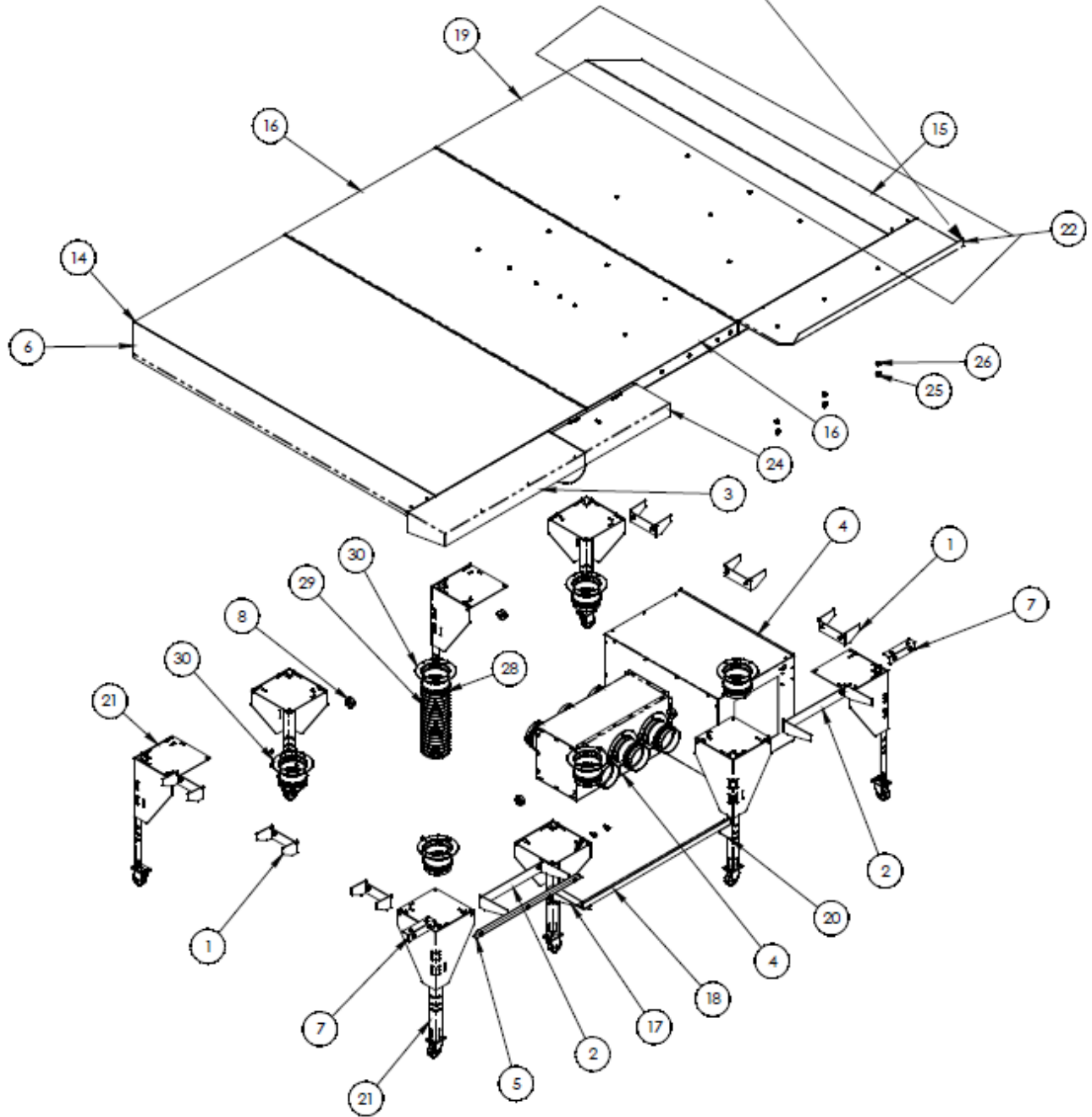

ITEM NO.	QTY.	PART NUMBER	DESCRIPTION
1	1	11334BY28P	AUTO FLANGING MODULE, PLC
2	1	1335000	AIR TABLE ASSY, AUTO
3	1	13351100	MAIN CONSOLE ASSY, PLC
4	1	13351068	THREAD GUIDE, RUFFLER
5	1	13351078	GUARD, ROTATE MOTOR
6	1	13351076	GUARD, RUFFLER BALL SCREW
7	1	13351077	GUARD, CONVEYOR MOTOR
8	4	WWF10	WASHER, FLAT, #10, COM
9	4	WWL10	WASHER, LOCK, #10
10	4	SSBC98040	10-32 X 5/8 BUTTON CAP SC
11	6	SSZH#10032	SCREW, SHT. METAL HEX 10

1335000 AIR TABLE ASSY, AUTO
AAC Drawing Number 1335000 Rev 4

TWO SHELVES SUPPORT EACH OTHER.



1335000 parts list

NOTES	ITEM NO.	QTY.	PART NUMBER	DESCRIPTION
	1	6	1335-0168B	SHELF SUPPORT
	2	2	1335-0168C	SHELF SUPPORT
	3	1	1335-0172A	EXTENSION, TABLE, 9"
	4	1	1335-0190	BLOWER BOX ASSY
	5	1	1335-172	EDGE GUIDE
	6	1	1335-175A	EXTENSION, TABLE
	7	2	1335-179	ANGLE,SHELF
	8	4	1335-180	SPACER, AIR TABLE
	NS	AR	1335000INS1	INSTRUCTIONAL,PARTS LIST
	NS	AR	1335000INS2	INSTRUCTIONAL,PARTS LIST
	NS	AR	1335000INS3	INSTRUCTIONAL,LEFT TABLE ASSY
	NS	AR	1335000INS4	INSTRUCTIONAL,RIGHT TABLE ASSY
	NS	AR	1335000INS5	INSTRUCTIONAL,AIR TABLE
	14	1	1335020	AIR TABLE, LEFT
	15	1	1335029	SHELF, LONG RIGHT, 9" EXT
	16	1	1335030	AIR TABLE ASSY,CENTER
	17	1	1335031	LATCH BRACKET
	18	1	1335032	AIR LOCK STRIKE
	19	1	1335040	AIR TABLE ASSY,RIGHT
	20	1	1335042	LATCH BRACKET
	21	8	1335050	LEG ASSEMBLY
	22	1	1335065	EXTENSION, TABLE, 12"
	NS	1	1335075	HARDWARE PACKAGE
	24	1	1335130	TRAP DOOR ASSEMBLY
	25	3	AA198RA510	REV FL CONT,5/32X10-32
	26	3	AAFJ11	SOFFIE JET & NUT ONLY
	27	2	CCCL8F	CLAMP COLLAR- 1/2
	28	12	MM5415K39	CLAMP,HOSE,WORM TYPE
	29	40FT*	MM5501K35	FLEX AIR DUCT,6" ID
	30	6	MMATTO6	TAKE OFF,6"

1335-0190 BLOWER ASSEMBLY
AAC Drawing Number 297096C Rev 15

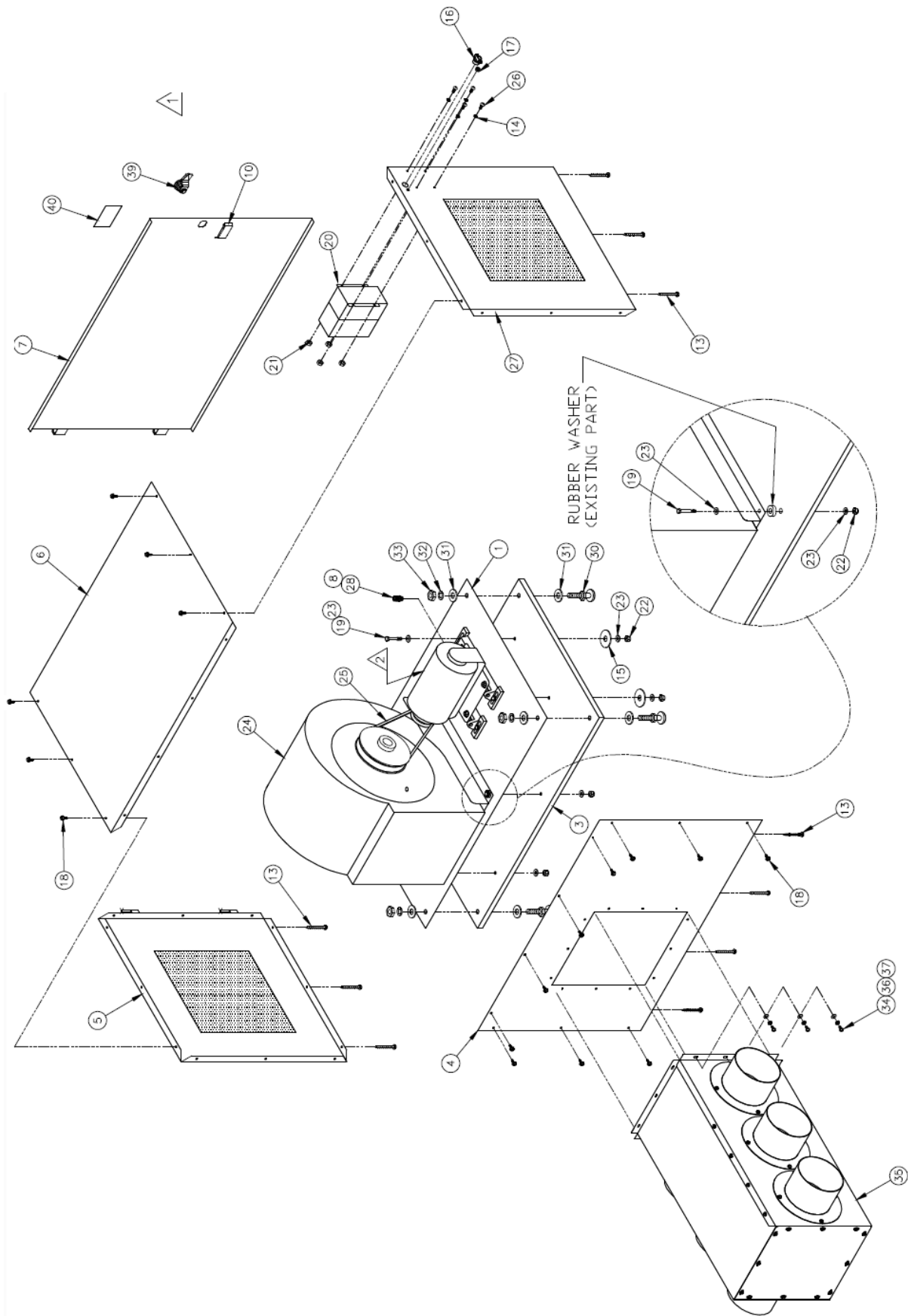

1335-0190 parts list

1	40	LABEL,ARC/SHOCK	001020
1	39	LATCH,1/4 TURN	MMELH-1
AR	38	MOTOR STARTER	K-CB600
12	37	WASHER, LOCK	WWL8
12	36	WASHER, FLAT	WWF8
1	35	DUCT ASSY.	1335099
12	34	SCREW, PAN PHILLIPS 8-32 x 3/8	SSPS90024
4	33	NUT, HEX, 1/2-13	NNH1/2-13
8	32	WASHER, FLAT, 1/2	WWF1/2
4	31	WASHER, LOCK, 1/2	WWL1/2
4	30	RUBBER FOOT	MMFB4444
1	29	4 PIN MALE CONN.	FF274-224
1	28	CONNECTOR	EEC403083
1	27	PANEL, LH. SIDE	1335-0192A
4	26	SCREW, BUTTON CAP 8-32 x 1/2	SSBC90032
1	25	V BELT	ZX5036
1	24	BLOWER	MM7D634
16	23	SAE FLAT WASHER	WWFS5/16
8	22	ELASTIC NUT	NNE5/16-18
4	21	NUT	NNK8-32
1	20	DRIVE, VAR.	MM510215B1M2
8	19	SCREW, HEX CAP 5/16-18 x 2	SSHC10128
16	18	SCREW, HEX SHEET METAL #10 x 1/2	SSZH#10032

1	17	HEYCO, BUSHING	EESB-375-4
1	16	ROMAX, CONNECTOR	K-235
4	15	FENDER WASHER	WWFE020
4	14	INTERNAL TOOTH WASHER	WWSI10
10	13	SCREW, HEX SHEET METAL #10 x 3/4	SSZH#10048
2.0	12	CABLE, 6 COND	FF1216
1	11	6 PIN MALE CONN.	FF274-226
1	10	SLIDE, LOCK	MM40450010
1.3	9	CABLE, 4 COND	EE16-4
1	8	LOKNUT,CONDUIT	MM655445
1	7	PANEL, DOOR	1335-0194
1	6	PANEL, TOP	1335-0193
1	5	PANEL, RT. SIDE	1335-0192
1	4	PANEL, REAR	1335-0191
1	3	BASE, BOX	1335-0189
AR	2	WIRING DIAGRAM	1335-0190WD
1	1	PLATE, BASE	1335-0187
QTY. RECD.	ITEM NO.	DESCRIPTION	PART NO. STOCK SIZE

1335030 AIR TABLE ASSEMBLY

AAC Drawing Number 1335030 Rev 4

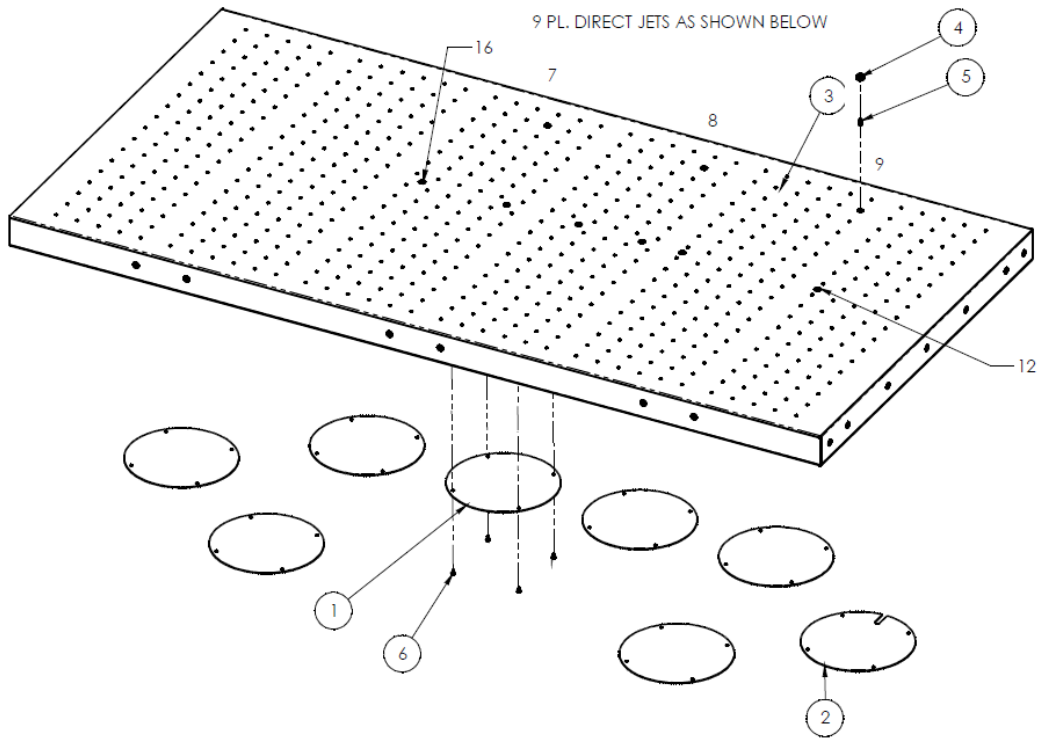

SOFFIE JET PLUMBLING

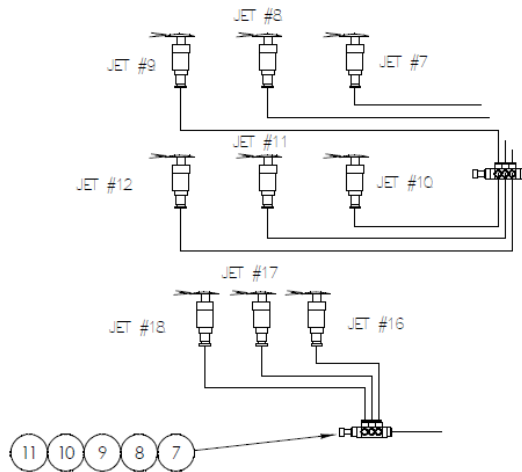

SOFFIE JET LOCATION AND DIRECTION

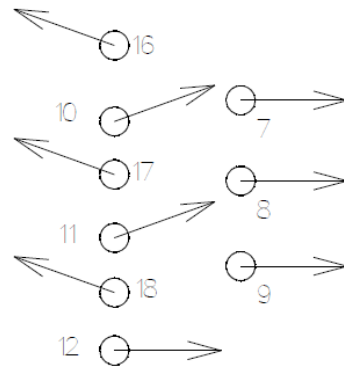

ITEM NO.	QTY	PART NUMBER	DESCRIPTION
1	7	1335012	ACCESS COVER
2	1	1335063	ACCESS COVER, W/SLOT
3	1	1335096	TABLE, AIR, CENTER
4	9	AAFJ11	SOFFIE JET & NUT ONLY
5	9	AAQMC-5-10	QUICK MALE CONNECT
6	32	SSZH#10032	SCREW, SHT. METAL HEX 10
7	2	AAQMF-144	MANIFOLD
8	3	AAQPP-07	PLUG, QUICK, 1/4 TUBE
9	2	AAQPP-11	PLUG, QUICK, 3/8 TUBE
10	1	AAQPR-3-4	QUICK PLUG-IN REDUCER
11	9	AAQPR-5-4	QUICK PLUG-IN REDUCER

1335040 AIR TABLE ASSEMBLY, RIGHT

AAC Drawing Number 1335040 Rev 4

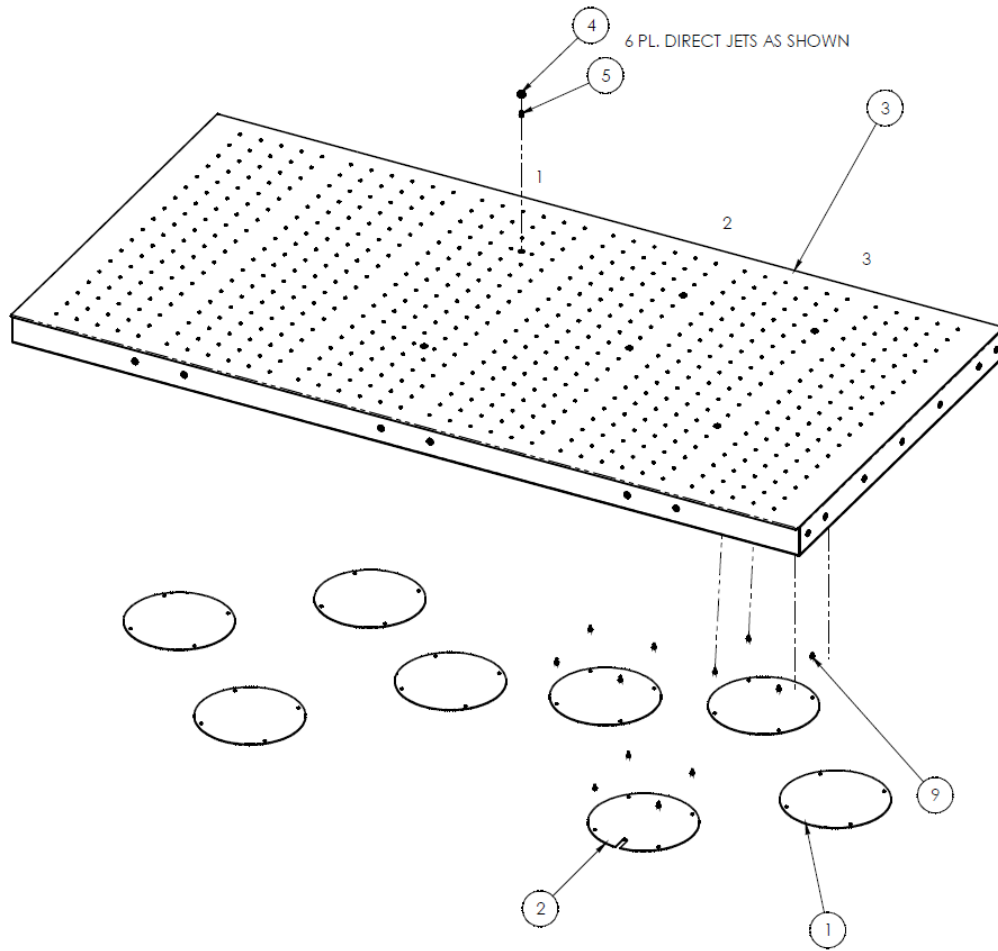

SOFFIE JET PLUMBING

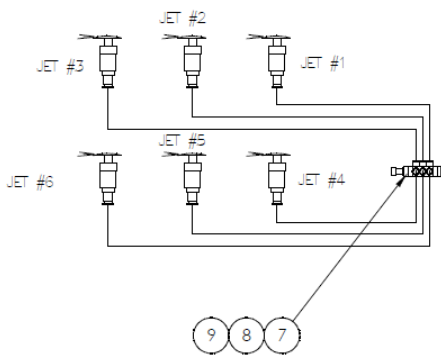

SOFFIE JET LOCATION AND DIRECTION

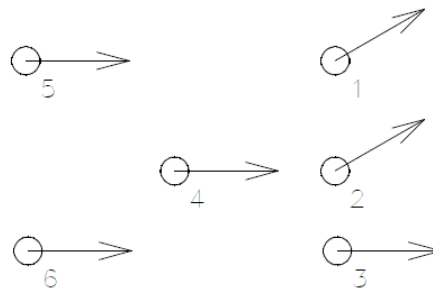

ITEM NO.	QTY	PART NUMBER	DESCRIPTION
1	7	1335012	ACCESS COVER
2	1	1335063	ACCESS COVER, W/SLOT
3	1	1335097	AIR TABLE, RIGHT
4	6	AAFJ11	SOFFIE JET & NUT ONLY
5	6	AAQMC-5-10	QUICK MALE CONNECT
6	1	AAQMF-144	MANIFOLD
7	1	AAQPP-11	PLUG, QUICK, 1/4 TUBE
8	6	AAQPR-5-4	QUICK PLUG-IN REDUCER
9	32	SSZH#10032	SCREW, SHT. METAL HEX 10

1335050 LEG ASSEMBLY

AAC Drawing Number 1335050 Rev 2

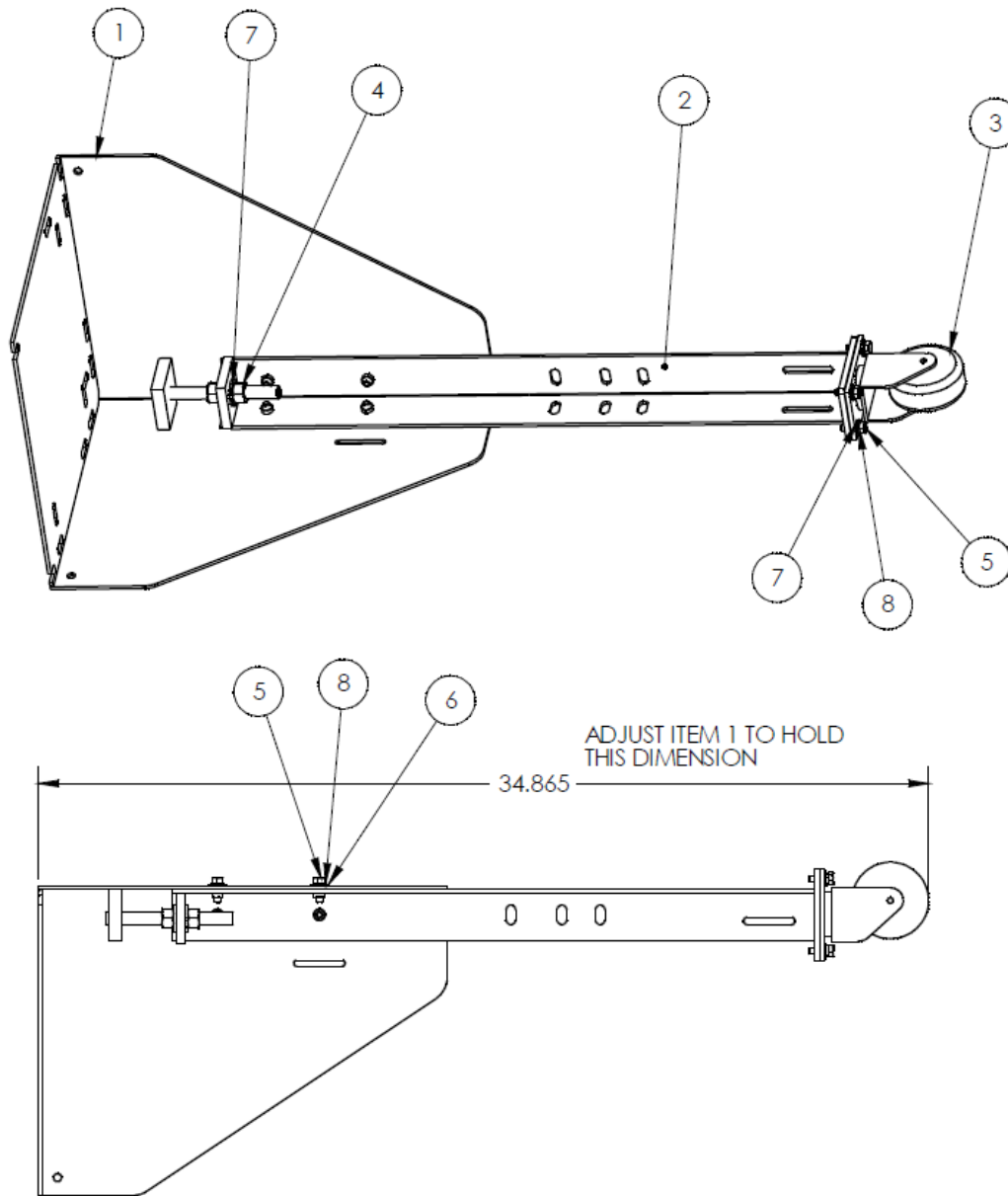

ITEM NO.	Hardware Shown/QTY.	PART NUMBER	DESCRIPTION
1	1	1335110	MOUNTING ASSEMBLY WELDMENT
2	1	1335120	LEG ASSEMBLY WELDMENT
3	1	MM427-3RB	CASTER, SWIVEL, 3" RUBBER
4	2	NNH3/8-16	3/8-16 HEX NUT
5	8	SSHCO1048	1/4-20 X 3/4 HEX HEAD
6	4	WWF1/4	WASHER, FLAT, 1/4", COM
7	6	WWFS1/4	WASHER FLAT, 1/4
8	8	WWL1/4	1/4 LW

1335130 TRAP DOOR ASSEMBLY

AAC Drawing Number 1335130 Rev 2

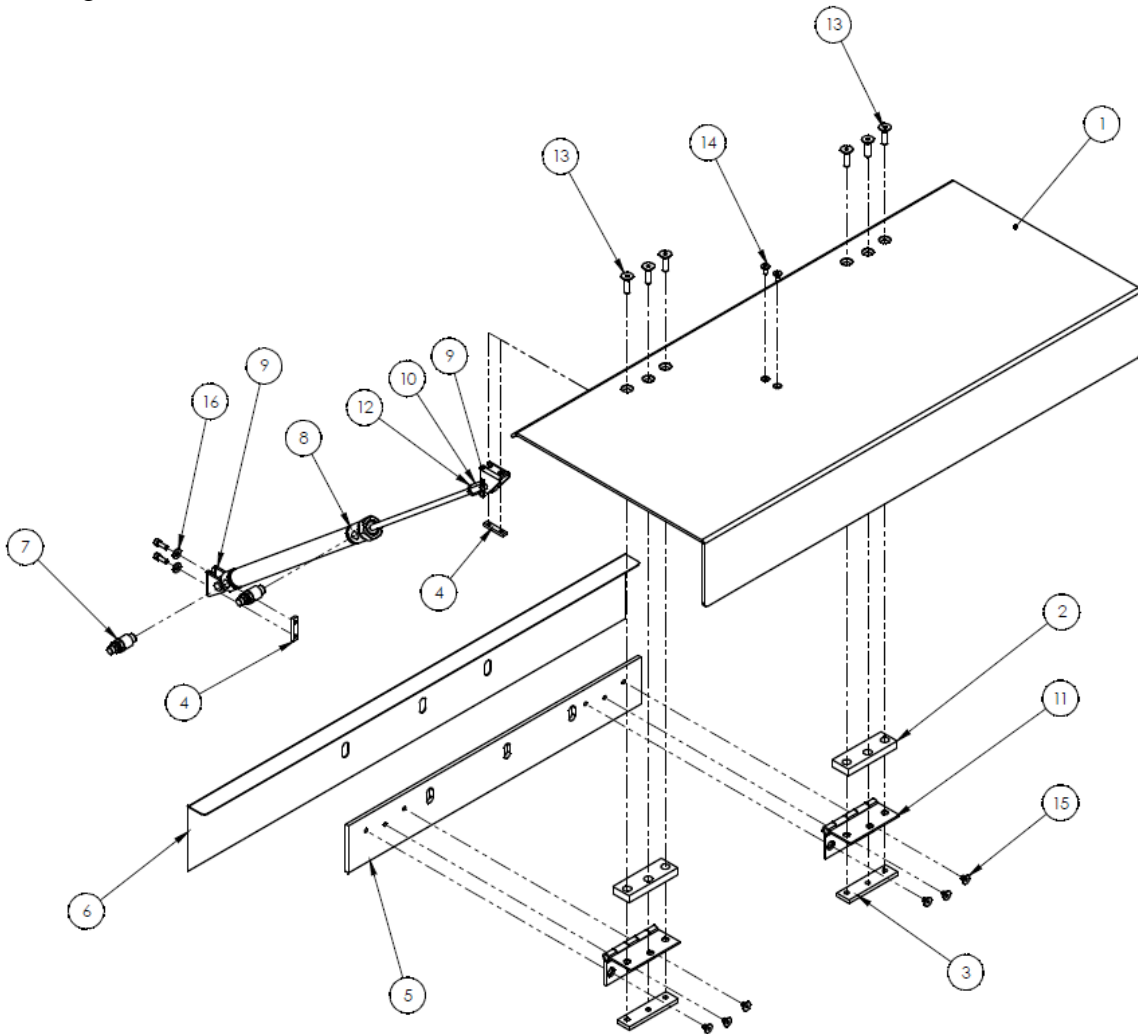

ITEM NO.	QTY.	PART NUMBER	DESCRIPTION
1	1	1335-143	TRAP DOOR
2	2	1335-146	WASHER PLATE
3	2	1335-149	PLATE,NUT 1/4-20 3 PL
4	2	1335-149A	PLATE,NUT,8-32@.75 CTC
5	1	1335039	HINGE MOUNTING
6	1	1335043	SHIELD
7	2	AA198RA508	FLOW CONTROL,5/32 X 1/8"
8	1	AAC7DP-8	CYLINDER,AIR,DA
9	2	AAFBP-11C	BRKT,PIVOT,1/4 BORE
10	1	BBAW-4	BEARING,ROD END,FEMALE
11	2	MM741-3A	HINGE,3 X 3,STANLEY
12	1	NNJ1/4-28	1/4-28 HEX JAM NUT
13	6	SSFC01056	1/4-20 X 7/8 FLAT ALLEN
14	2	SSFC90024	#8-32 X 3/8 FLAT ALLEN
15	6	SSFC98016	#10-32 X 1/4 FLAT ALLEN
16	2	WWF8	WASHER, FLAT #8
17	2	SSSC90032	#8-32 X 1/2 Lg. SHCS

11334BY28P Auto Flanging Module

AAC Drawing Number 9009030 Rev 1

ITEM NO.	QTY.	PART NUMBER	DESCRIPTION
1	1	0411-069B	BRKT, THREAD BREAK DETECT
2	1	0411-070	CLAMP, SENSOR BRACKET
3	1	0411-1051	YAM BELT GUARD STAND OFF BRKT
4	1	0411-1052	YAMATO GUARD MODIFICATION
5	1	1334-1000A	SEWING HEAD ASSY COMPLETE
6	1	1334-1100F	FOLDER MOUNT ASSY
7	1	1334-1200	MATERIAL GUIDE ASBLY
8	1	1334-2000	FRAME ASSY, AUTO 1334
9	1	1334BP-WD	DIAGRAM, WIRING
10	1	1959-112	2 POS THREAD PLATE ASSY
11	2	4003-500C	THREAD BREAK SENSOR ASSY
12	2	4080-4205	CABLE,ENCODER, 6 FT
13	1	1334062	CONTROL PANEL, 1334B
14	1	1334430	THREE ROLL HOLDER FOR
15	4	NNK1/4-20	NUT,KEP,1/4-20
16	16	SSHC01040	1/4-20 X 5/8 HHCS
17	2	SSHC01064	1/4-20 X 1 HHCS
18	4	SSHC01160	1/4-20 X 2-1/2 HHCS
19	4	SSSC01048	1/4-20 X 3/4" SOC CAP SC
20	1	SSSC98032	10-32X1/2, SOC CAP
21	26	WWFS1/4	WASHER,FLAT,SAE,1/4
22	1	WWFS10	WASHER, FLAT, #10, SAE
23	18	WWL1/4	WASHER,LOCK, 1/4
24	1	WWL10	WASHER,LOCK,#10

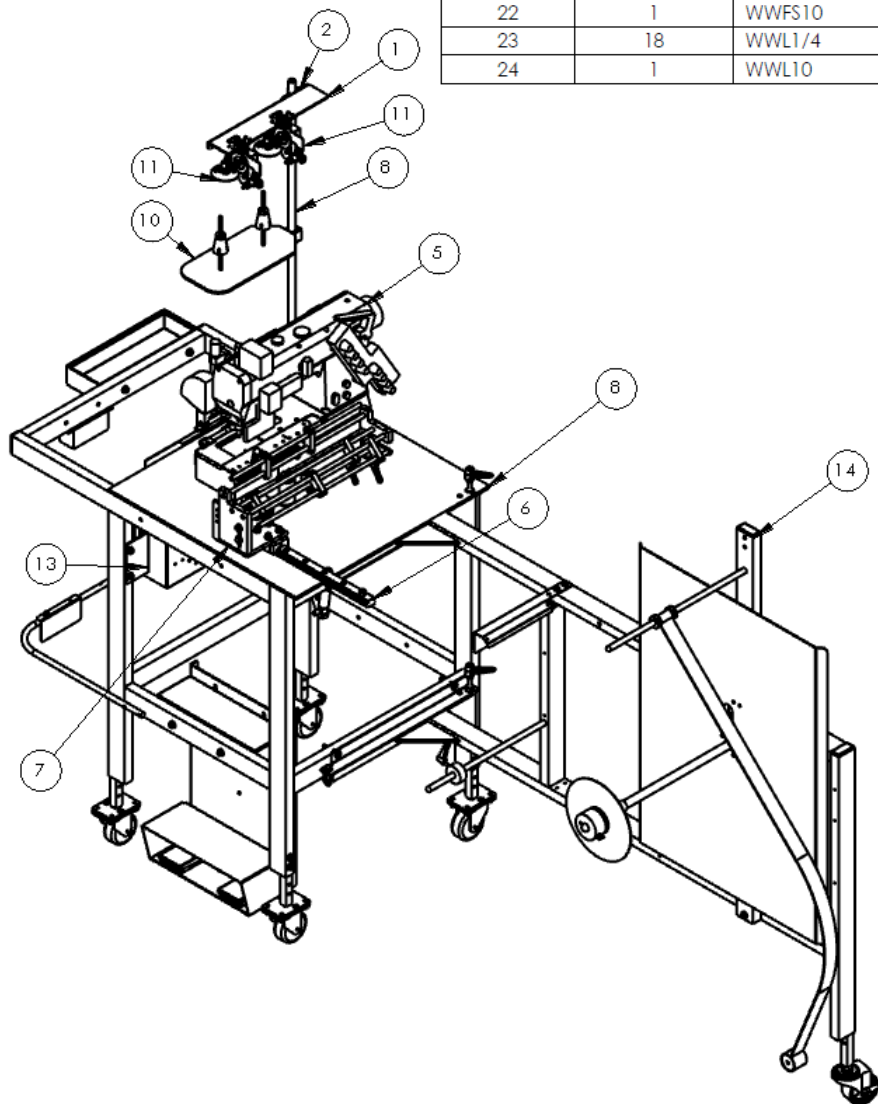

1334-1000A Sewing Head Assembly

AAC Drawing Number 192557C Rev 3

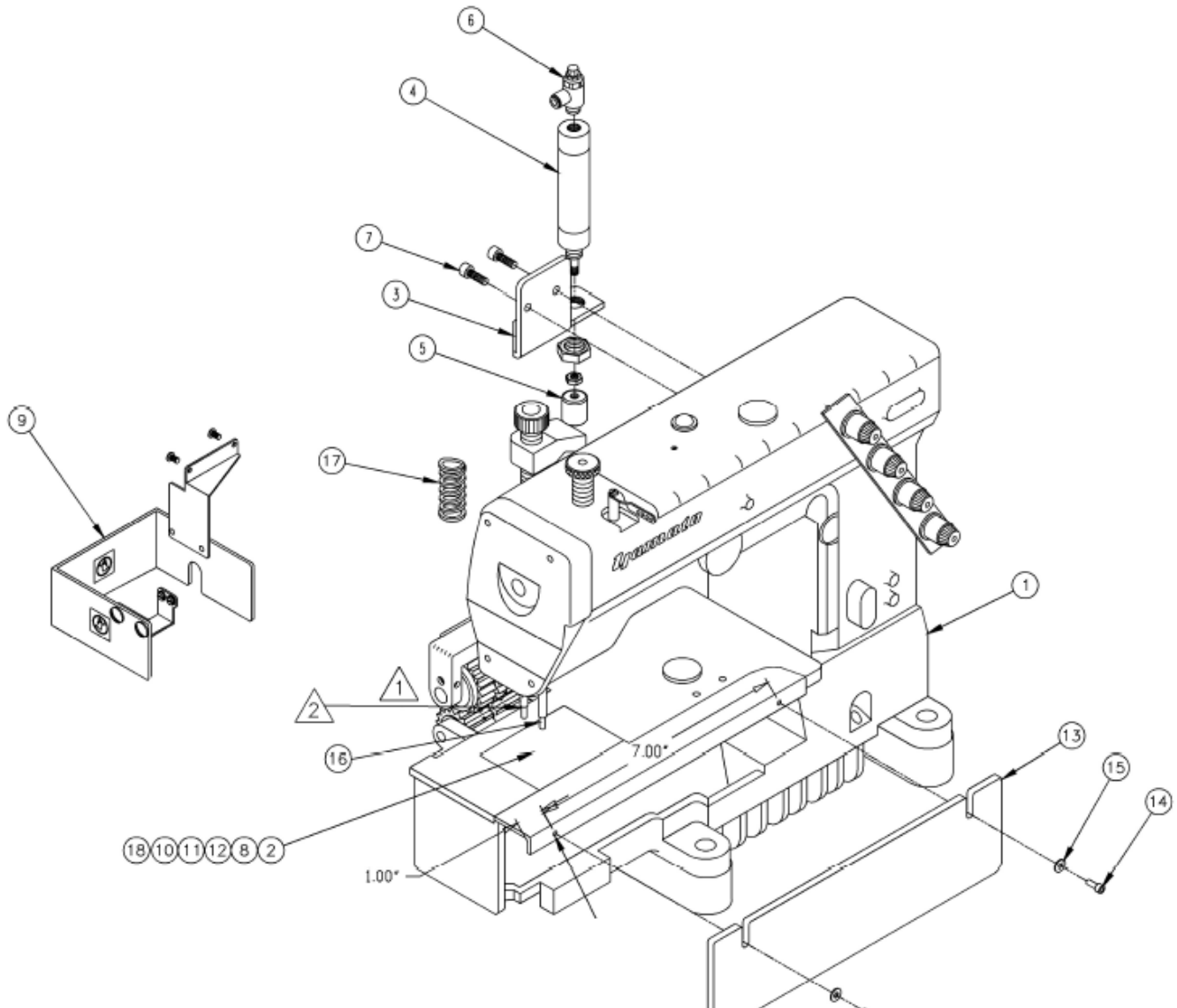

1	10	FEED DOG	54205A9016
1	9	GUARD	1959-412
1	8	SPREADER	54242B9016
2	7	SCREW, SOCKET CAP M6 X 1 X 16MM	SSSCM6X16
1	6	FLOW CONTROL	AA198RR508
1	5	BUMPER	11200A
1	4	AIR CYLINDER	AAC6S-1-H
1	3	BRACKET	112013
1	2	NEEDLE HOLDER	1862N94016
1	1	YAM. SEWING HD.	SYAM-1804A
QTY. REQD.	ITEM NO.	DESCRIPTION	PART NO. STOCK SIZE

10	19	NEEDLE,SYS UY113,SIZE 18	SN11318GB
1	18	LOOPER HOLDER	1862N95016
1	17	SPRING, PULLER	RRLC105J10
1	16	NEEDLE BAR MOD	3300012M
2	15	FLAT WASHER	WWFS10
2	14	SCREW,SOCKET CAP	SSSC98032
1	13	GUARD,THRD GUIDES	1334041
1	12	THROAT PLATE	54224A9016
1	11	PRESSER FOOT	54420X9016
QTY. REQD.	ITEM NO.	DESCRIPTION	PART NO. STOCK SIZE

1334-1100F FOLDER MOUNT ASSY

AAC Drawing Number 90081038 Rev 0

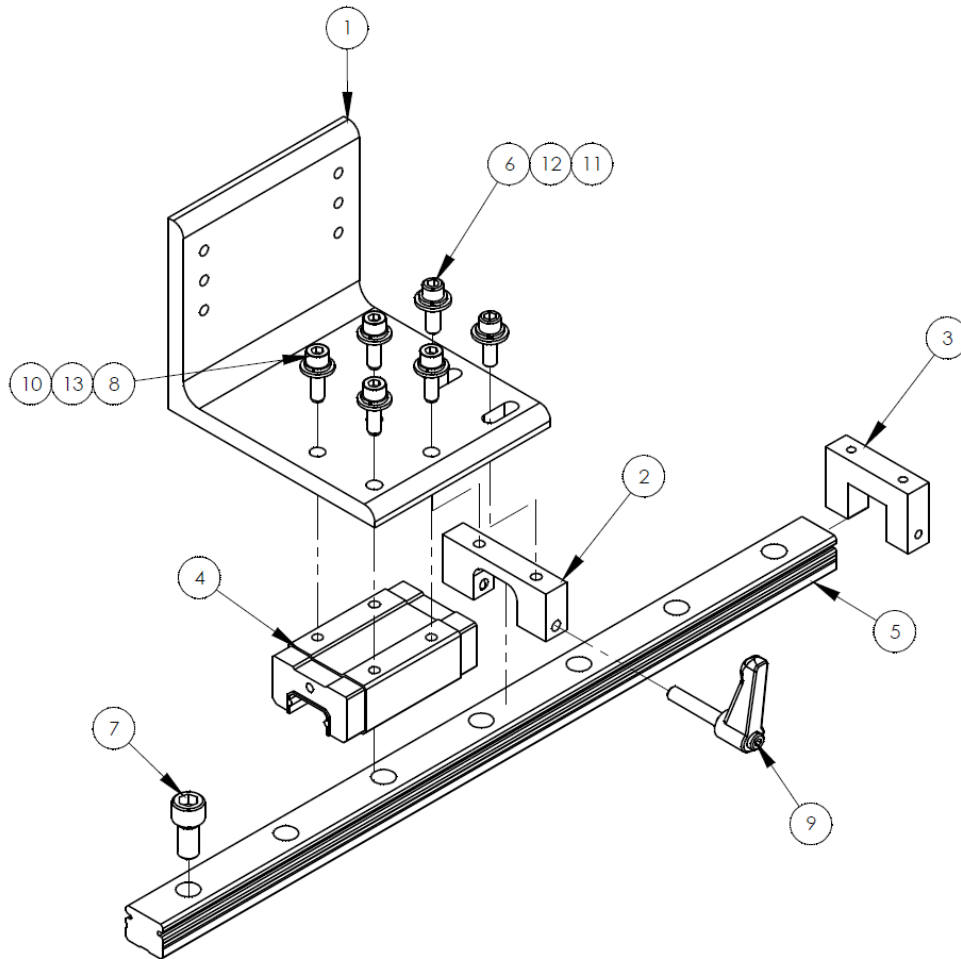

ITEM NO.	QTY.	PART NUMBER	DESCRIPTION
1	1	1334-1005A	MOUNT, ANGLE, LOWER
2	1	1334-1006	MOUNT, LOCKING HANDLE
3	1	1335-310	STOP BLOCK, FRONT
4	1	MMEGH25CA	LINEAR BEARING
5	1	MMEGR25R0414CM	RAIL, MODIFIED
6	2	SSSC01048	1/4-20 X 3/4" SOC CAP SC
7	1	SSSC25048	3/8-16 X 3/4 SOC CAP
8	4	SSSCM6X20	M6 X 20, SOC CAP
9	1	TTH32416	HANDLE, THRD, 1/4-20 X 1-1/8
10	4	WWFM6.1	WASHER, FLAT, M6, SAE
11	2	WWFS1/4	WASHER, FLAT, SAE, 1/4
12	2	WWL1/4	WASHER, LOCK, 1/4
13	4	WWLM6	WASHER, LOCK, M6

1334-1200 MATERIAL GUIDE ASSEMBLY

AAC Drawing Number 192930C Rev 1

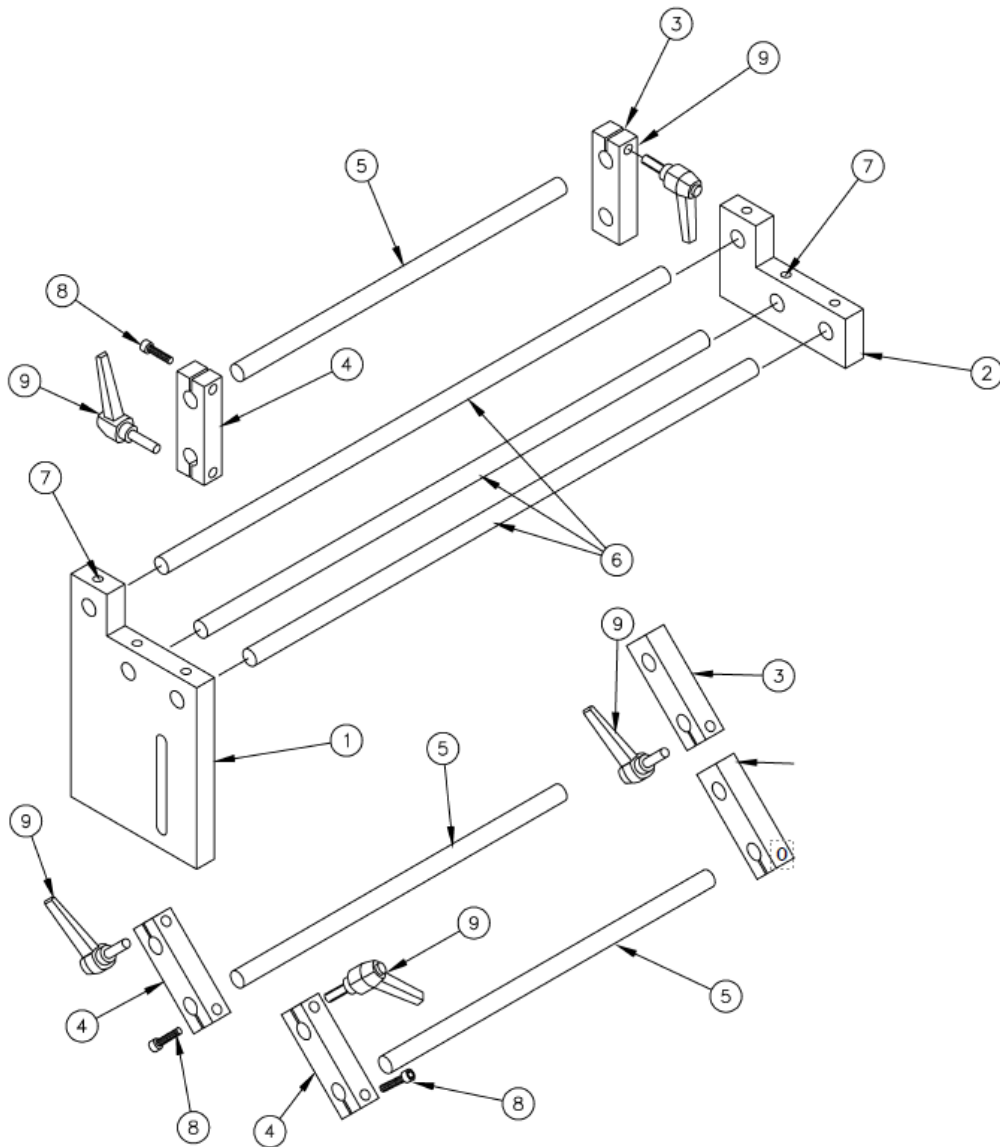

6	9	10-24 HANDLE	TTH34311
3	8	SCREW, SOCKET CAP 10-24 X 3/4	SSSC95048
6	7	SCREW, SOCKET SET 1/4-20 X 3/8	SSSS01024
3	6	ROD, 3/8 X 16	1335Q-131
3	5	ROD, 3/8 X 9	1335-320C
3	4	ARM, ROD CLAMP	1335-319
3	3	ARM, ROD SLIDE	1335-318
1	2	SUPPORT	1334-1024
1	1	MOUNT, GUIDE	1334-1023
QTY. REQD.	ITEM NO.	DESCRIPTION	PART NO. STOCK SIZE

1334-2000 FRAME ASSEMBLY
 AAC Drawing Number 192536C Rev10

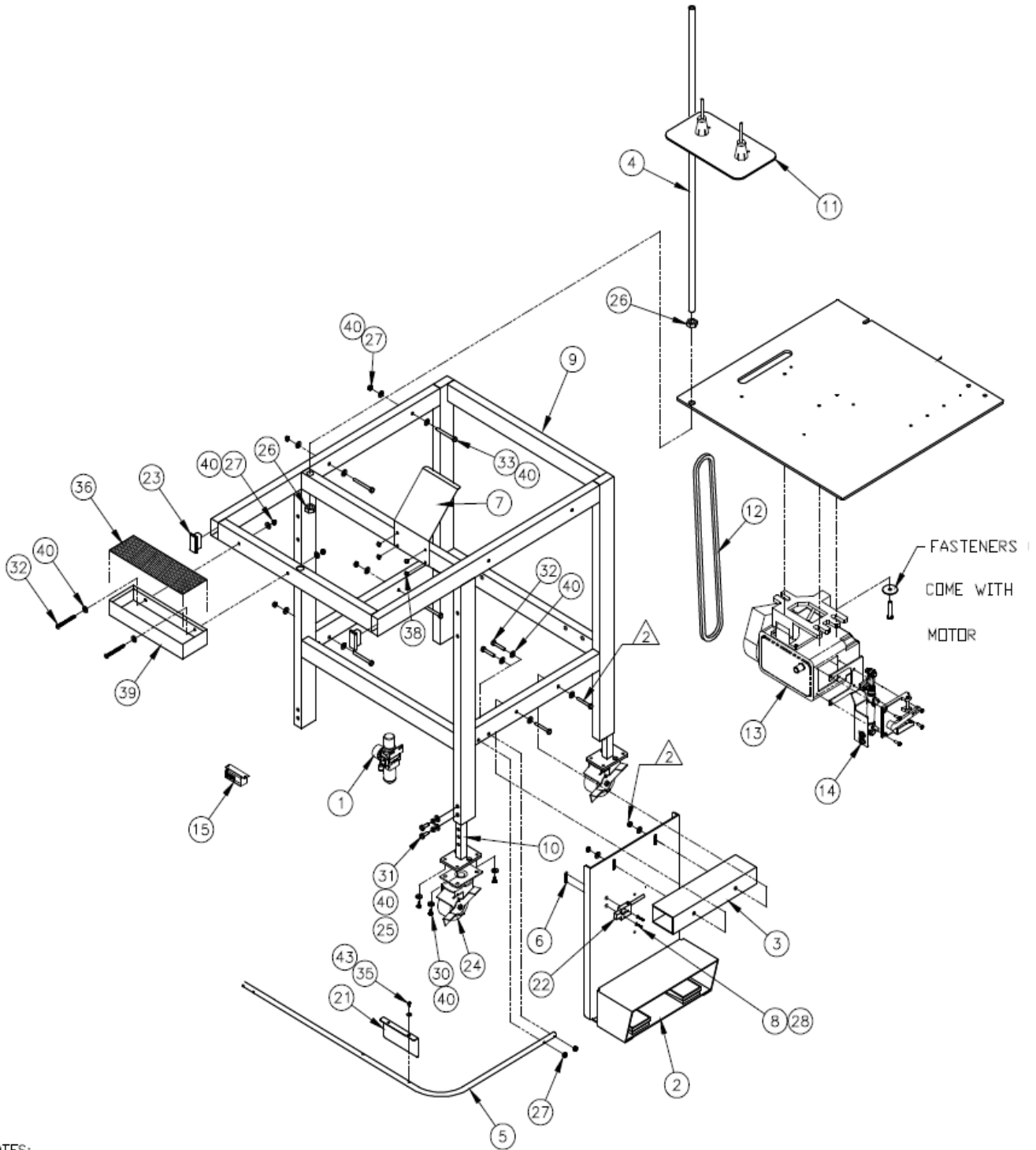

NOTES:

1334-2000 parts list

26	40	FLAT WASHER	WWFS1/4
1	39	TRAY, TOOL	1335-190
4	38	SCREW, TRUSS, HD SLOTTED 10-32 X 1/4	SSTS98016
2	37	SCREW, SOCKET CAP 1/4-20 X 1	SSSC01064
1	36	PAD, NON SLIP	1335-191
1	35	SCREW, HEX, CAP 10-32 X 3/8	SSHC98024
1	34	CABLE, DUAL	FFRK44T3PD
4	33	SCREW, HEX, CAP 1/4-20 X 2-1/2	SSHC01160
4	32	SCREW, BUTTON, CAP 1/4-20 X 1-1/2	SSBC01096
4	31	SCREW, HEX, CAP 1/4-20 X 3/4	SSHC01048
8	30	SCREW, HEX, CAP 1/4-20 X 5/8	SSHC01040
1	29	ON/OFF SWITCH	T75
2	28	FLAT WASHER	WWF4
10	27	KEP NUT, 1/4-20	NNK1/4-20
2	26	JAM NUT	NNJ5/8-18
4	25	LOCK WASHER	WWL1/4
2	24	CASTER, SWIVEL	MM427-3RB
2	23	END CAP	MM132-1496
1	22	ELECTRIC EYE	FFSM312LVQ
1	21	BRKT, LOOP PHOTOCELL	1335-2025
9'	20	CABLE, 3 COND	FF19510
25	19	CABLE TIE	EE6X750
1	18	PLUG, 3 POLE	FFHBL4570C
1	17	WASHER, FLAT, SAE, #10	WWFS10
8	16	1/8" CLAMP	AAF1/8
1	15	ON/OFF SWITCH	T75
1	14	MOTOR LEVER ASSY	4059067
1	13	CLUTCH MOTOR	4058-3
1	12	V BELT	ZX3834
1	11	2 POS THREAD PLATE ASSY	1959-112
2	10	LEG, WELDMENT	1961-115
1	9	FRAME, AUTO FLANGE	1334-2100
2	8	SCREW, PAN HEAD, SLOTTED 4-40 X 3/4	SSPS70048
1	7	GUIDE	1334-2012
1	6	NUT PLATE	1975-412A
1	5	GUARD, SLACK	1334-2008
1	4	SUP, THRD STAND	1334-1004
1	3	SPACER, FT PDL	132556-013
1	2	FOOT PEDAL ASSY	132556-011
1	1	REGULATOR	AA198-5102
QTY. RECD.	ITEM NO.	DESCRIPTION	PART NO. STOCK SIZE

4059067 MOTOR LEVER ASSEMBLY

AAC Drawing Number 4059067 Rev 0

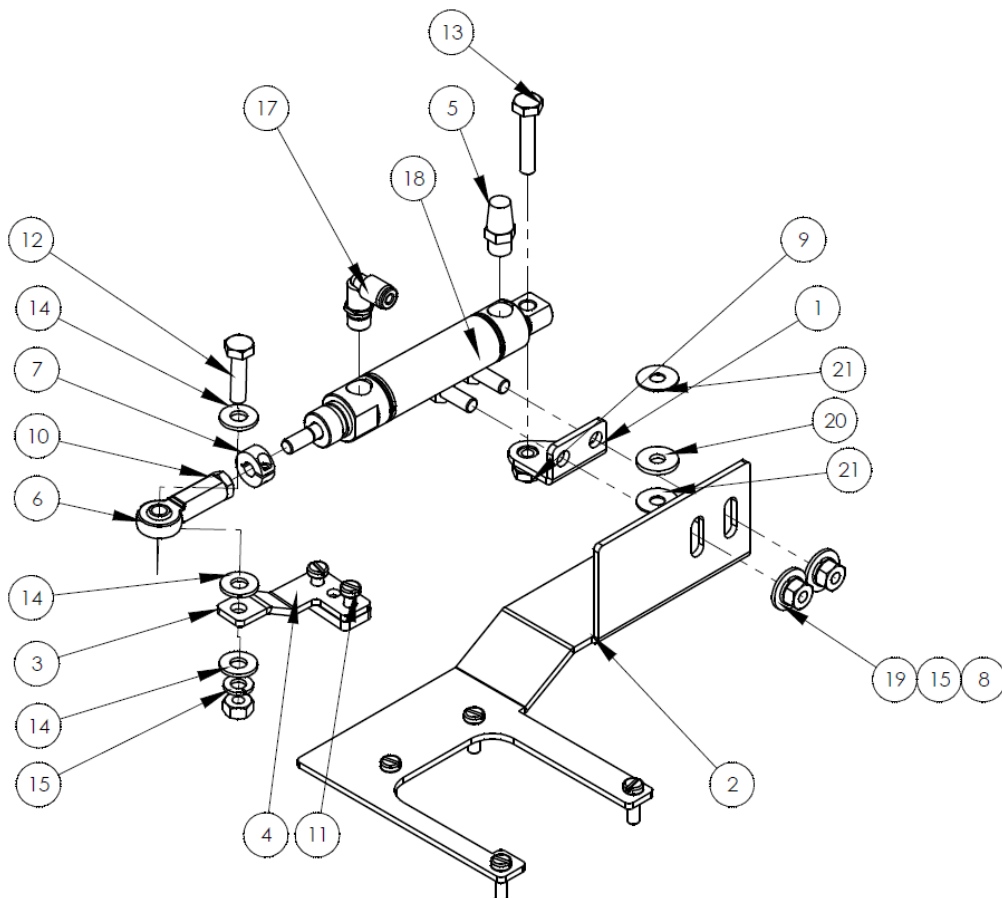

ITEM NO.	QTY.	PART NUMBER	DESCRIPTION
1	1	1278-6310	CYLINDER MOUNT
2	1	4059064	MOTOR, LEVER, CYL BRACKET
3	1	4059065	MOTOR, LEVER, SEWQUIET
4	1	4059066	NUT PLATE M5X0.8,.789 CTC
5	1	AAFP18	MUFFLER,1/8 NPT, BRONZ
6	1	BBAW-4	BEARING,ROD END,FEMALE
7	1	CCCL4F	COLLAR,1/4,CLAMP
8	3	NNH1/4-20	NUT,HEX,1/4-20
9	1	NNJ1/4-20	NUT, HEX, JAM, 1/4-20
10	1	NNJ1/4-28	NUT, HEX, JAM, 1/4-28
11	6	SSCM5X16	SCREW,CHEESE HEAD
12	1	SSHC01064	1/4-20 X 1 HHCS
13	1	SSHC01080	1/4-20 X 1-1/4 HHCS
14	3	WWFS1/4	WASHER,FLAT,SAE,1/4
15	3	WWL1/4	WASHER,LOCK, 1/4
16	1	AAC7DP-1	
17	1	AAQME-5-8	QUICK MALE ELBOW
18	2	SSHC01040	1/4-20 X 5/8 HHCS
19	2	WWF1/4	WASHER, FLAT, 1/4", COM
20	2	BBNTA411	BEARING,THRUST,.250B
21	4	BBTRA411	WASHER,THRUST,STEEL

132556-011 DUAL FOOT PEDAL ASSEMBLY

AAC Drawing Number 125506b Rev 3

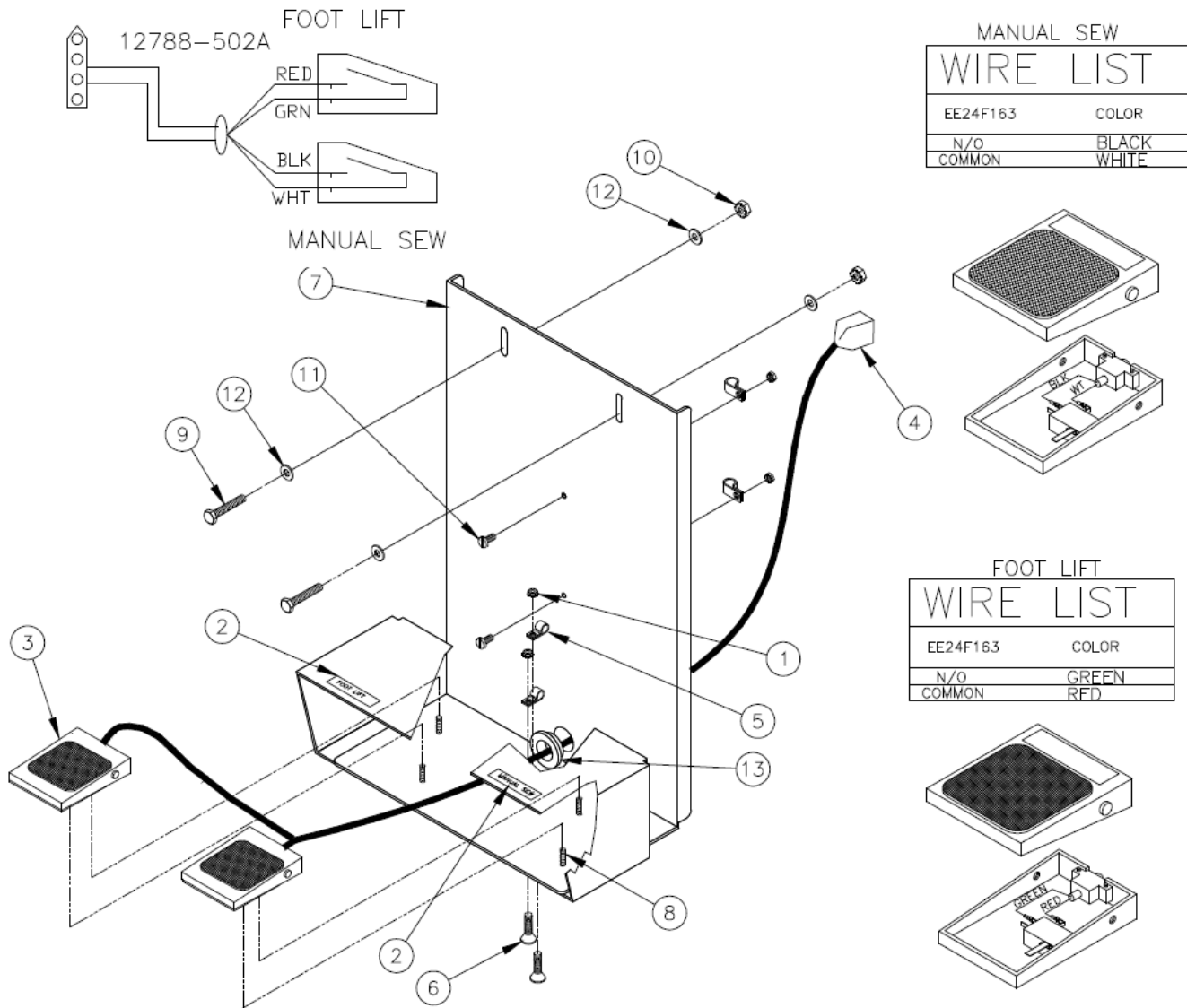

MANUAL SEW

WIRE LIST	
EE24F163	COLOR
N/O	BLACK
COMMON	WHITE

FOOT LIFT

WIRE LIST	
EE24F163	COLOR
N/O	GREEN
COMMON	RED

4	8	SCREW, FLAT ALLEN CAP 6-32 x 1/4	SSFC80016
1	7	PLATE, FOOT PEDAL	132556-010
2	6	SCREW, FLAT ALLEN CAP 6-32 x 3/8	SSFC80024
4	5	CLAMP, BLK	AAF3/16
1	4	CABLE ASSY	12788-502A
2	3	FOOT SWITCH MOD	1278-6161
AR	2	LABEL	132556-012L
4	1	6-32 KEP NUT	NNK6-32
QTY. REQD.	ITEM NO.	DESCRIPTION	PART NO. STOCK SIZE

2	9	SCREW, HEX CAP 1/4-20 X 1 1/2	SSHCO1096
2	10	KEP NUT	NNK1/4-20
2	11	SCREW, PAN HD SLOTTED 6-32 x 3/8	SSPS80024
4	12	SAE FLAT WASHER	WWFS1/4
1	13	GROMMET,RUBBER	MM9600K36

13351100 MAIN CONSOLE ASSY, PLC

AAC Drawing Number 13351100 Rev 0

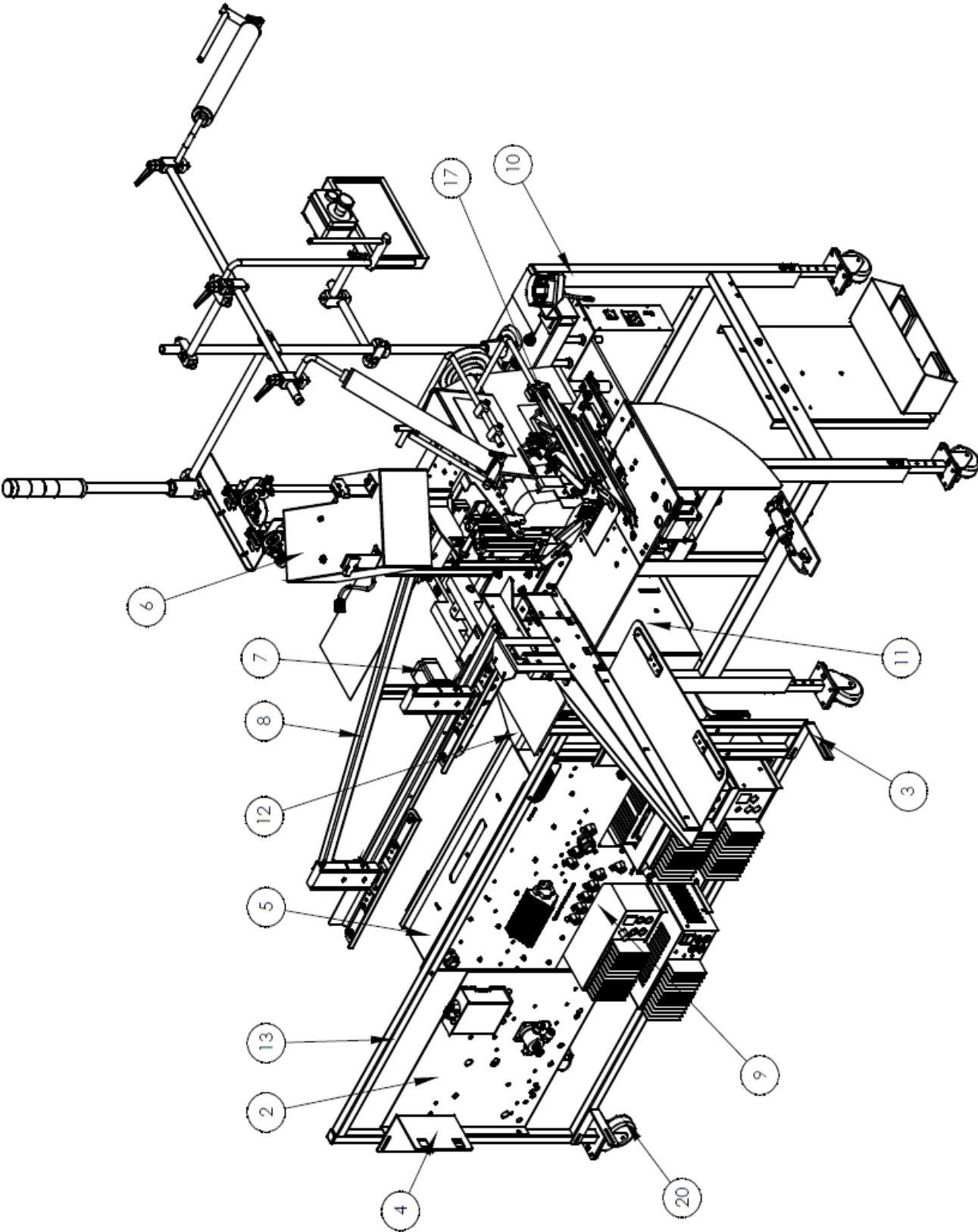

13351100 parts list

ITEM NO.	QTY.	PART NUMBER	DESCRIPTION
1	2	1335-134	PLATE,UPPER HINGE
2	1	1335060	PNEUMATIC PANEL ASSY
3	2	1335073	BRACKET, LOWER LEG
4	2	1335074	PLATE, MOUNTING
5	2	1335091	BOX SUPPORT ANGLE
6	1	13351012	ROTATE ASSY, 1335BS88
7	1	13351030	REAR CONVEYOR ASSY, 1335C
8	1	13351045	ROTATE & CLAMP ARM ASSY
9	1	13351109	ELECTRICAL PANEL ASSY 1335BS
10	1	13351110	STAND, HEAD, & MOTOR, 300UX5
11	1	13351111	MAIN SOLENOID PANEL ASSY
12	2	1335170	PIVOT ARM WELDMENT
13	1	1335180	FRAME, EP/NP
14	1	1335B-PD1	PNEUMATIC DIAGRAM
15	1	1335B-WD1	WIRING DIAGRAM, SBUS I/O
16	1	1335B-WD2	WIRING DIAGRAM, POWER
17	1	A-2216X4X2X3/8	GUSSET GUIDE, 4X2X3/8
18	4	CCCL8F	CLAMP COLLAR- 1/2
19	2	MM132-1202	END CAP,SQUARE,BLACK
20	1	MM427-3RB	CASTER,SWIVEL,3"RUBBER

1335060 PNEUMATIC PANEL ASSEMBLY

AAC Drawing Number 192837C Rev 0

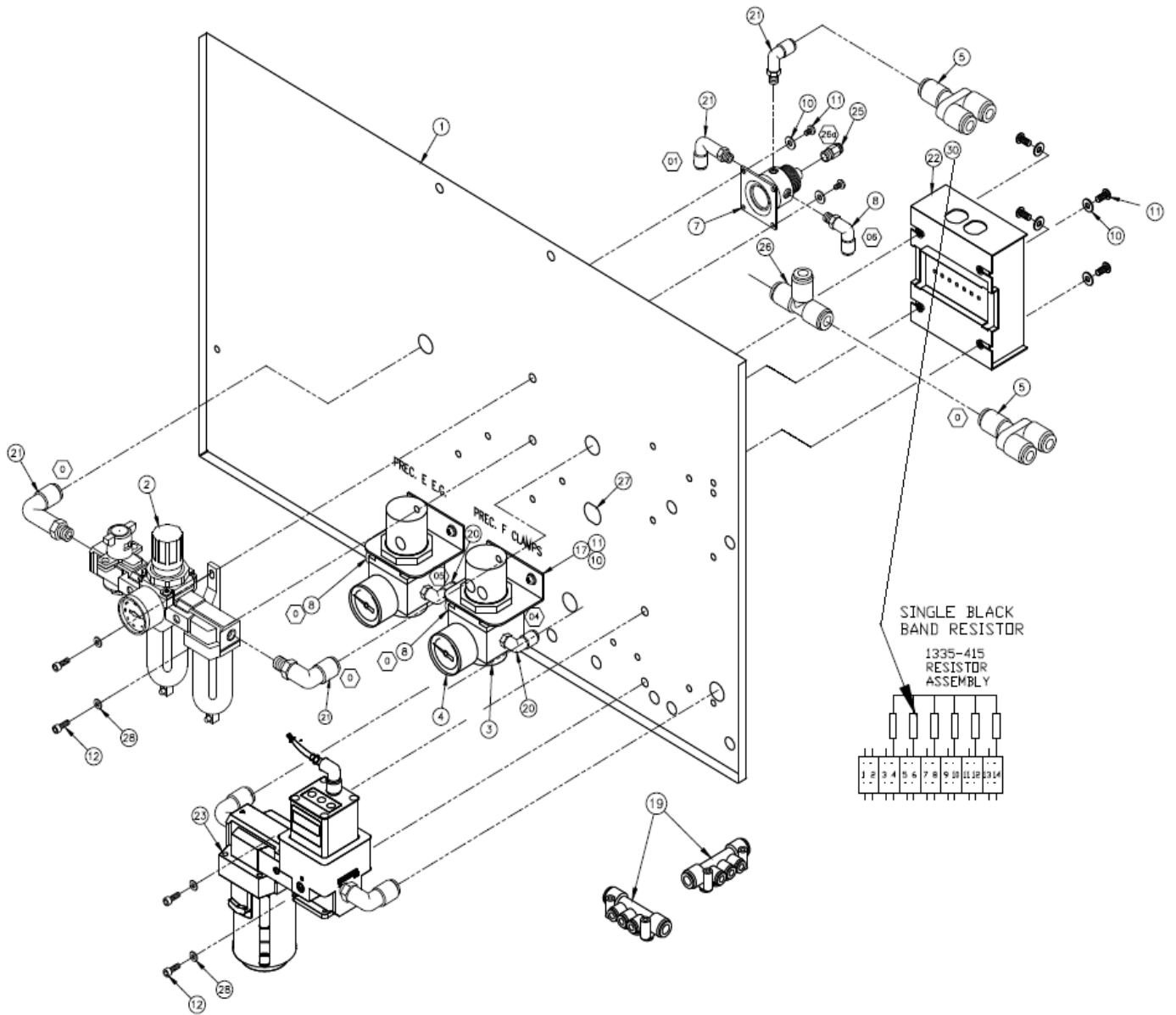

1335060 parts list

AR	31	PNEU DIAGRAM	1335Q-PD2
1	30	RESISTOR ASSY	1335-415
4	29	WASHER, LOCK 10	WWL10
4	28	WASHER, FLAT SAE	WWFS1/4
1	27	STRAIN RELIEF	FF1724
1	26	QUICK UNION TEE	AAQUT-3-3
1	25	QUICK MALE CONNECT	AAQMC-5-8
1	23	REGULATOR,ELE/PNEU	AA198-3050
1	22	JUNCTION BOX	4080-800
6	21	QUICK MALE ELBOW	AAQME-3-4
2	20	QUICK MALE ELBOW	AAQME-5-4
2	19	6-STA AIR MANIFOLD	AAQMF-144
1	18	QUICK UNION Y	AAQUY-5-4
2	17	REGULATOR BRKT	0411-071
6	16	UNION, QUICK STATION	AAQSU-4-4
AR	15	PNEUMATIC DIAGRAM	1335060-PD
10	14	REDUCER	AAQPR-5-4
11	13	QUICK UNION Y	AAQUY-4-4
4	12	SCREW, SOCKET CAP 1/4-20 X 3/4	SSSC01048
10	11	SCREW, PAN HD PHILIPS 10-32 X 3/8	SSPP98024
10	10	SAE FLAT WASHER	WWFS10
1	9	QUICK MALE ELBOW	AAQME-5-8
3	8	QUICK MALE ELBOW	AAQME-4-4
1	7	PILOT VALVE	AAV250A
5	6	PLUG REDUCER	AAQPR-3-4
4	5	QUICK UNION Y	AAQUY-3-3
2			
2	4	GAUGE, 0-30 PSI	AA198-503
2	3	AIR REGULATOR	AA198-RP3
1	2	FILTER/REG./LOCKOUT	AA198-5110
1	1	PANEL	1335068
QTY. REQD.	ITEM NO.	DESCRIPTION	PART NO. STOCK SIZE

13351030 REAR CONVEYOR ASSEMBLY
AAC Drawing Number 13351030 Rev 0

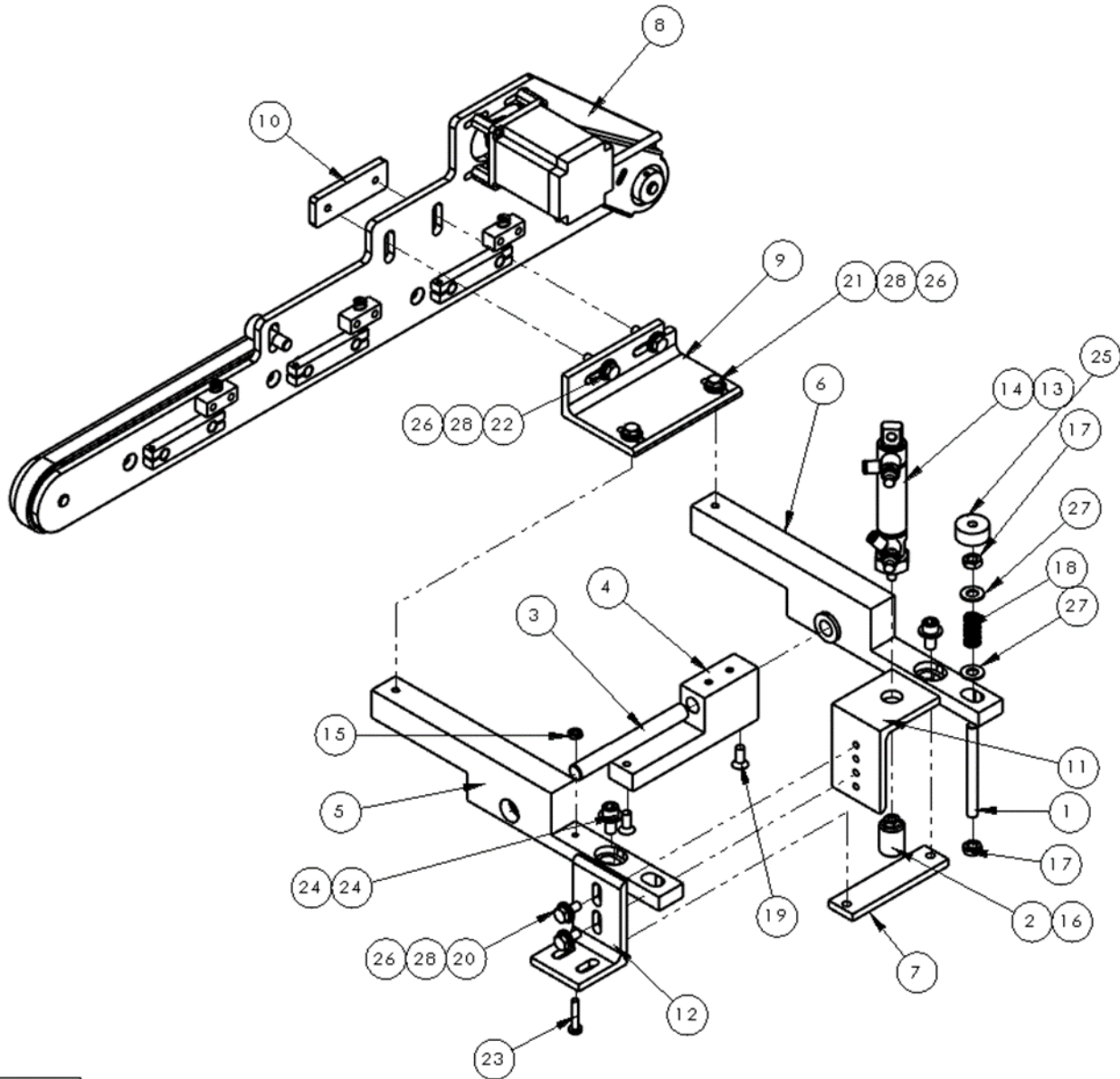

1331030 parts list

ITEM NO.	QTY.	PART NUMBER	DESCRIPTION
1	1	010-054	ROD, THREADED, 5/16 X 3.25
2	1	11200	BUMPER, 1/4-28
3	1	1335-609	SHAFT, FLATTED, 0.5D 4.5L
4	1	1335-622A	BLOCK, PIVOT, REAR CONV
5	1	1335-623A	ARM, CONVEYOR PIVOT, LH
6	1	1335-623B	ARM, CONVEYOR PIVOT, RH
7	1	1335-624A	BRACE, REAR CONVEYOR
8	1	13351029	CONVEYOR SUB-ASSY
9	1	13351032	CONVEYOR MOUNTING ANGLE
10	1	1335M-131	PLATE, NUT, 1/4-20 @ 2.0
11	1	265018	BRACKET, CONV LIFT CYL
12	1	265019	MOUNT, CONV. CYL.
13	2	AA198RA508	FLOW CONTROL, 5/32 X 1/8"
14	1	AAC7D-1	CYLINDER, AIR, DA 3/4 BORE,
15	1	NNH10-32	HEX-NUT 10-32 REG.
16	1	NNJ1/4-20	NUT, HEX, JAM, 1/4-20
17	2	NNJ5/16-18	NUT, JAM, 5/16-18
18	1	RRLC055G5	SPRING, COMP .055 X .48 X 1
19	2	SSFC01040	1/4-20 X 5/8 FLAT ALN CAP
20	3	SSHC01040	1/4-20 X 5/8 HHCS
21	2	SSHC01048	1/4-20 X 3/4 HEX CAP
22	2	SSHC01064	1/4-20 X 1 HHCS
23	1	SSPS98064	#10-32 X 1 PAN HD SLTD
24	2	SSSC10040	5/16-18 X 5/8 SOC CAP
25	1	TTK32308	TORQUE KNOB,
26	7	WWFS1/4	WASHER, FLAT, SAE, 1/4
27	4	WWFS5/16	WASHER, FLAT, SAE, 5/16
28	7	WWL1/4	WASHER, LOCK, 1/4

13351029 CONVEYOR SUB-ASSEMBLY
AAC Drawing Number 13351029 Rev 1

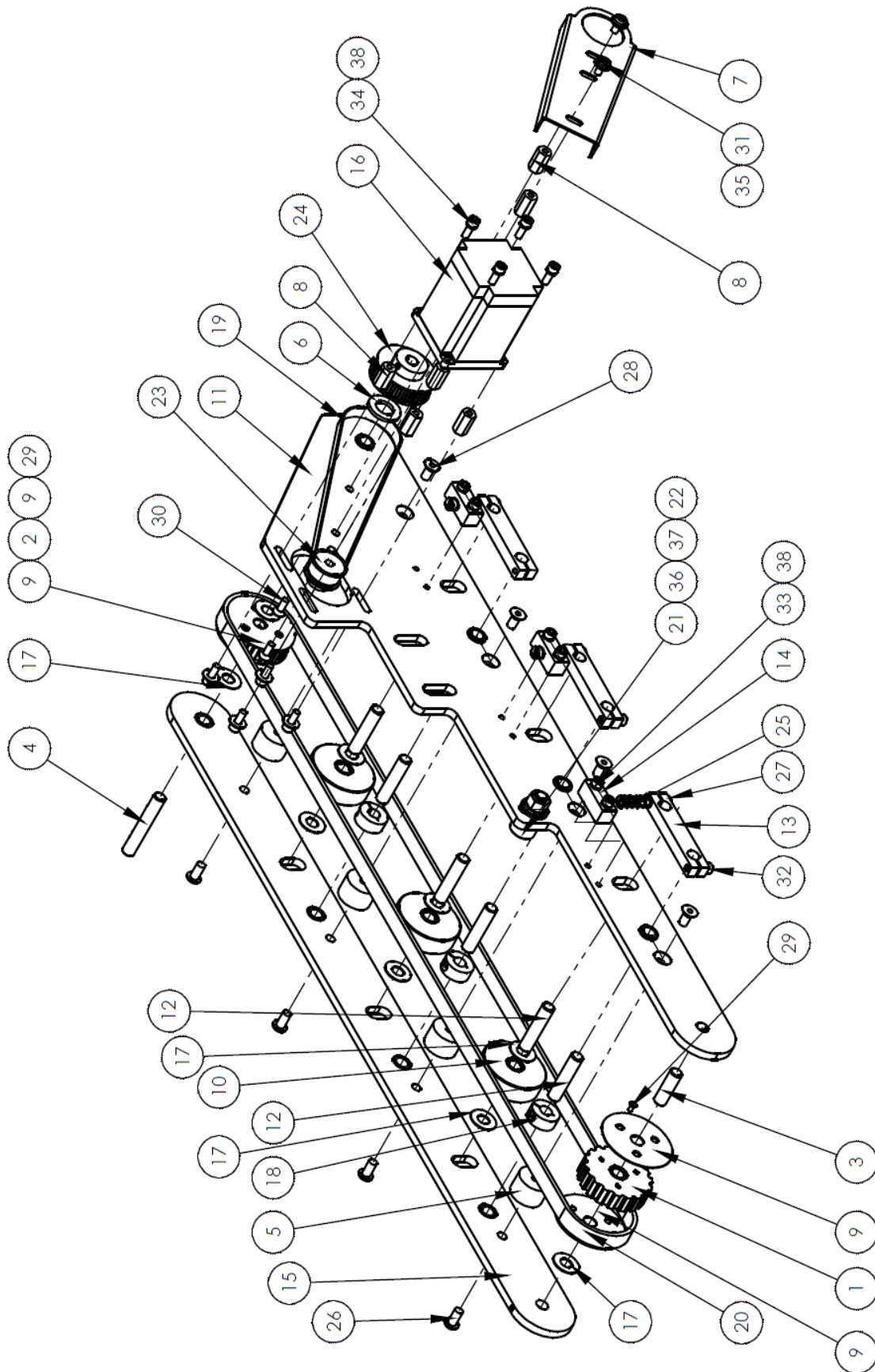

13351029 parts list

ITEM NO.	QTY.	PART NUMBER	DESCRIPTION	ITEM NO.	QTY.	PART NUMBER	DESCRIPTION
1	1	1335-601	PULLEY, IDLER	20	1	GGD540L050NM	BELT, GEAR, NOMARK
2	1	1335-602	PULLEY, DRIVE	21	1	MMCCF3/4SB	CAM FOLLOWER, 3/4 DIA
3	1	1335-603	SHAFT, IDLER	22	1	NNH3/8-24	NUT, HEX, 3/8-24
4	1	1335-604	DRIVE SHAFT	23	1	PP14XL037M	PULLEY, GEAR, 1/5P, 14T, 1/4B
5	4	1335-607	SPACER	24	1	PP28XLB037M	PULLEY, GEAR, 1/5P, 28T, 1/2B
6	1	1335-608	SPACER	25	3	RRLC029E9	SPRING, COMP .029X.36X1.0
7	1	1335-610	COVER, BELT	26	4	SSBC01032	1/4-20 X 1/2 BUT CAP SC
8	6	1335-611	COVER, STANDOFF	27	3	SSBC95064	10-24 X 1 BUTTON CAP SC
9	4	1335-619	FLANGE, PULLEY	28	4	SSFC01032	1/4-20 X 1/2 FLAT ALN CAP
10	3	1335-620	ROLLER	29	4	SSFC70016	4-40 X 1/4 FLAT SOC CAP
11	1	13351028	RIGHT CONV. SIDE - W/BUSHINGS	30	2	SSFC98032	10-32 X 1/2 FLAT ALLEN CAP
12	6	13351031	SHAFT, IDLER, 1.45L	31	2	SSPS98024	10-32X3/8 PAN HD SLOT
13	3	13351033	ROLLER PIVOT ARM	32	2	SSSC95040	10-24 X5/8, SOC CAP
14	3	13351034	SPRING HOLDER	33	6	SSSC95048	10-24 X 3/4, SOC CAP
15	1	13351035	SIDEPLATE, INSIDE	34	8	SSSC98032	10-32X1/2, SOC CAP
16	1	AP-22E-103	STEP MOTOR, 2 AMP	35	6	WWF10	WASHER, FLAT, #10, COM
17	10	BBTRA613	WASHER, THRUST, STL, .375B	36	2	WWFS3/8	WASHER, FLAT, SAE, 3/8
18	3	CCCL6F	CLAMP COLLAR- 3/8	37	1	WWL3/8	WASHER, LOCK, 3/8
19	1	GG180XL037	BELT, GEAR, 1/5P, 3/8W	38	14	WWL10	WASHER, LOCK, #10

13351045 ROTATE & CLAMP ARM ASSEMBLY

AAC Drawing Number 13351045 Rev 0

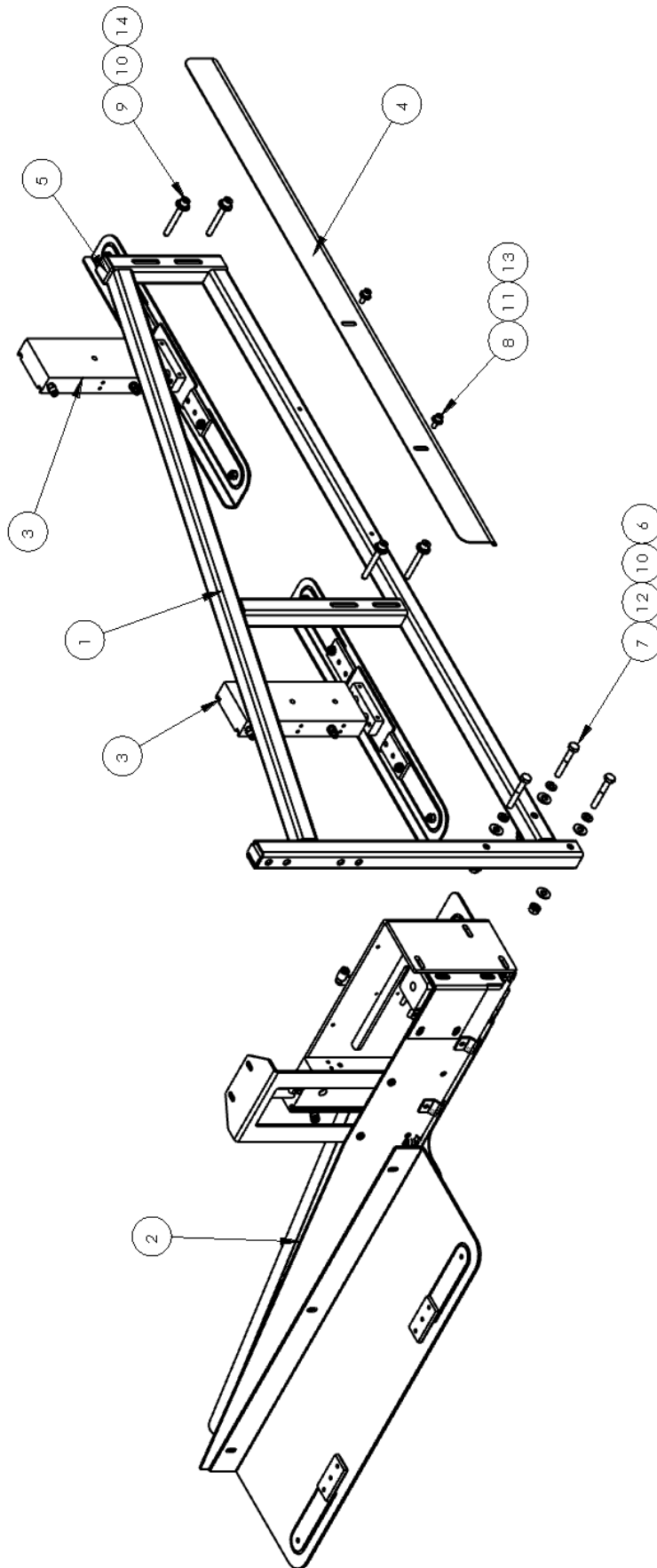

TRIPLE

13351045 parts list

ITEM NO.	QTY.	PART NUMBER	DESCRIPTION
1	1	13351040	SWING ARM WELDMENT
2	1	13351044	FRONT CLAMP ASSY
3	2	13351052	REAR ROTATE CLAMP ASSY
4	1	13351055	BUMPER SHIELD
5	1	MM132-1202	END CAP,SQUARE,BLACK
6	3	NNK1/4-20	NUT,KEP,1/4-20
7	3	SSHC01112	1/4-20 X 1-3/4 HHCS
8	2	SSSC98032	10-32X1/2, SOC CAP
9	4	SSSCM6X50	M6X50 SOC CAP SCREW
10	10	WWFS1/4	WASHER,FLAT,SAE,1/4
11	2	WWFS10	WASHER, FLAT, #10, SAE
12	3	WWL1/4	WASHER,LOCK, 1/4
13	2	WWL10	WASHER,LOCK,#10
14	4	WWLM6	WASHER,LOCK,M6

13351044 FRONT CLAMP ASSY

AAC Drawing Number 13351044 Rev 1

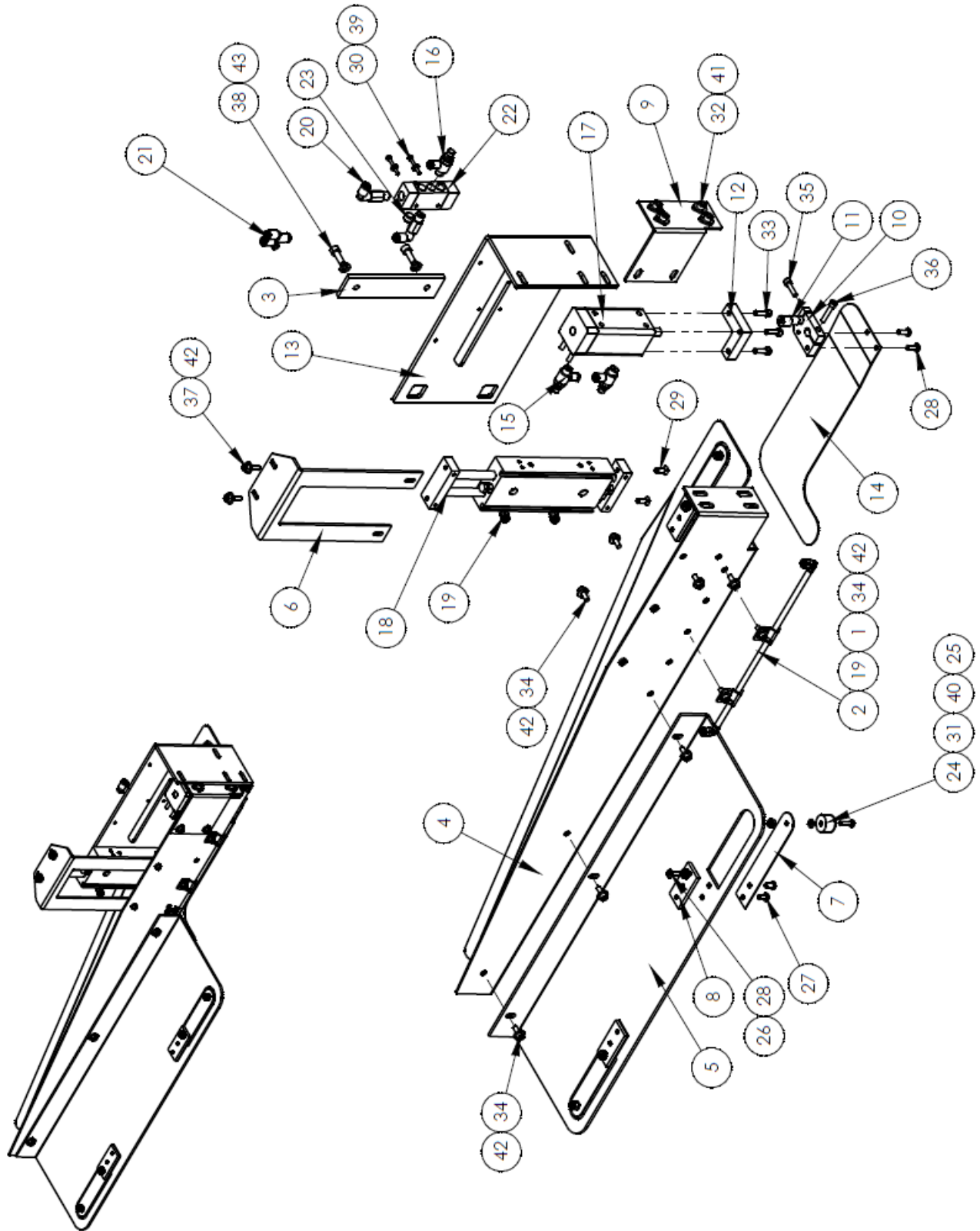

13351044 parts list

ITEM NO.	QTY	PART NUMBER	DESCRIPTION	ITEM NO.	QTY	PART NUMBER	DESCRIPTION
1	2	0411-2126	CLAMP, UNCURLER TUBE	23	1	MM4554K11	PLUG, 1/8" PIPE
2	1	2112-601A	TUBE, BLOWER	24	3	MM9540K22	BUMPER, 3/4 DIA
3	1	132556-214A	PLATE, WASHER, 1/4, 3.94 CTC	25	3	NNE8-32	NUT, ELASTIC LOCK, 8-32
4	1	132556-277D	PLATE, FRONT	26	3	NNK10-32	KEP NUT, 10-32
5	1	132556-277E	BRKT, FRONT FLANGE 1	27	6	SSBC98024	10-32 X 3/8 BUTION CAP SC
6	1	132556-277F	BRACKET, FRONT ROTATE	28	5	SSBC98032	10-32 X 1/2 BUTION CAP SC
7	3	132556-280	SPRING	29	2	SSFCM5X14	M5-0.8X14, FLAT ALLEN
8	3	132556-281	SPRING PLATE	30	2	SSPS70064	4-40 X 1 PAN HD SLOTTED
9	1	132556-283	BRKT, ROTATOR BRACE	31	3	SSPS90040	8-32 X 5/8 PAN HD
10	1	1325021	ARM, PRESSURE PLATE	32	4	SSSC01032	1/4-20X1/2 SOC CAP
11	1	1325022	ECCENTRIC, ADJ STOP	33	3	SSSC95040	10-24 X5/8, SOC CAP
12	1	1325023	STOP BKT, PRESS PLATE	34	9	SSSC98032	10-32X1/2, SOC CAP
13	1	13351048	ROTATE CYL MNT	35	1	SSSC98048	10-32 X 3/4 SOC CAP
14	1	13351065	PLATE, PRESSURE	36	1	SSSC98064	10-32 X 1 SOC CAP
15	2	AA198RA508	FLOW CONTROL, 5/32 X 1/8"	37	2	SSSCM5X16	M5-0.8 X 16, SOC CAP SCR
16	1	AA198RR508	FLOW CONTROL, 5/32 X 1/8"	38	2	SSSCM6X20	M6 X 20, SOC CAP
17	1	AACS3204	ACTUATOR, ROTARY, 32IP, 3/8	39	2	WWWF4	WASHER, FLAT, #4
18	1	AACXSWM2050	CYL, AIR, DUAL ROD	40	3	WWWF8	WASHER, FLAT, #8
19	4	AAQME-5-10	AIR ELBOW, 10-32 X 5/32	41	4	WWF1/4	WASHER, FLAT, SAE, 1/4
20	2	AAQMEL-5-8	QUICK MALE ELBOW, LONG	42	11	WWF10	WASHER, FLAT, #10, SAE
21	1	AAQUY-5-5	QUICK UNION Y, 5/32	43	2	WWL1/4	WASHER, LOCK, 1/4
22	1	AAV180-4A2	DOUBLE PILOT VALVE				

13351052 REAR ROTATE CLAMP ASSY

AAC Drawing Number 13351052 Rev 0

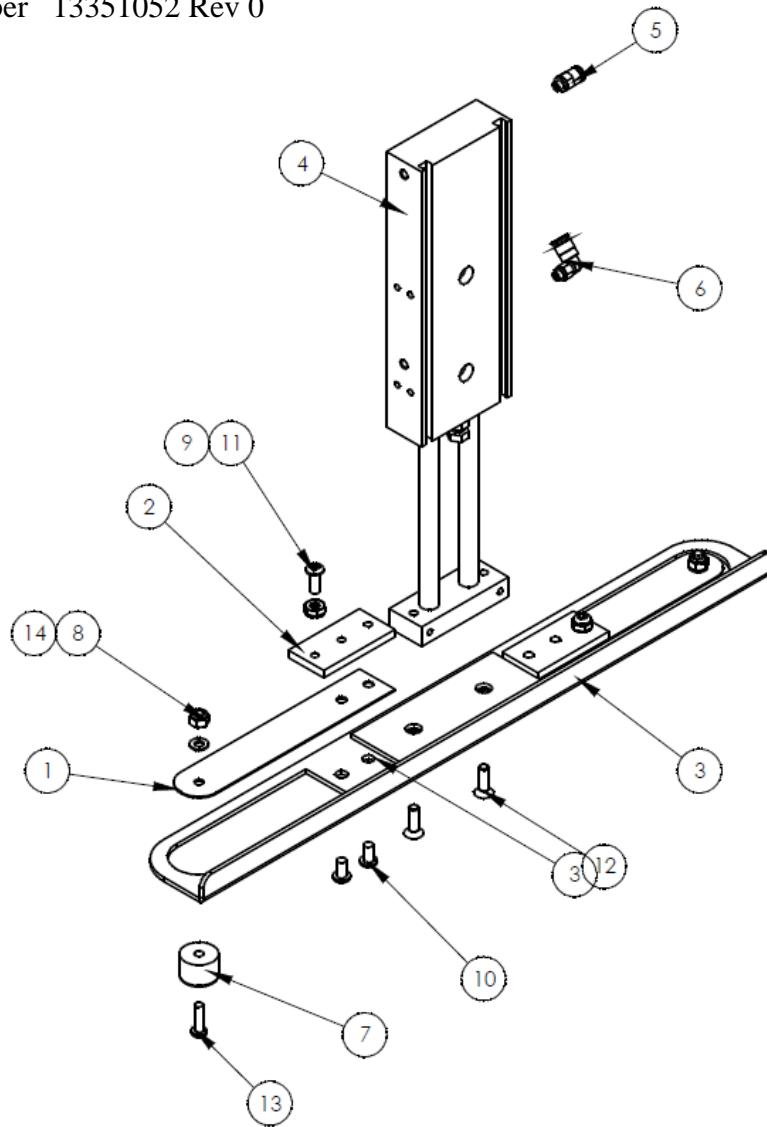

ITEM NO.	QTY.	PART NUMBER	DESCRIPTION
1	2	132556-280	SPRING
2	2	132556-281	SPRING PLATE
3	1	13351053	CLAMP & ROTATE RAIL
4	1	AACXSM20100	CYLINDER,AIR,DUAL ROD
5	1	AAQMC-5-10	QUICK MALE CONNECT
6	1	AAQME-5-10	AIR ELBOW, 10-32 X 5/32
7	2	MM9540K22	BUMPER, 3/4 DIA
8	2	NNE8-32	NUT,ELASTIC LOCK, 8-32
9	2	NNK10-32	KEP NUT, 10-32
10	4	SSBC98024	10-32 X 3/8 BUTTON CAP SC
11	2	SSBC98032	10-32 X 1/2 BUTTON CAP SC
12	2	SSFCM5X16	M5-0.8X16, FLAT ALLEN
13	2	SSPS90040	8-32 X 5/8 PAN HD
14	2	WWF8	WASHER, FLAT, #8

13351109 ELECTRICAL PANEL ASSY 1335BS

AAC Drawing Number 13351109 Rev 3

13351009

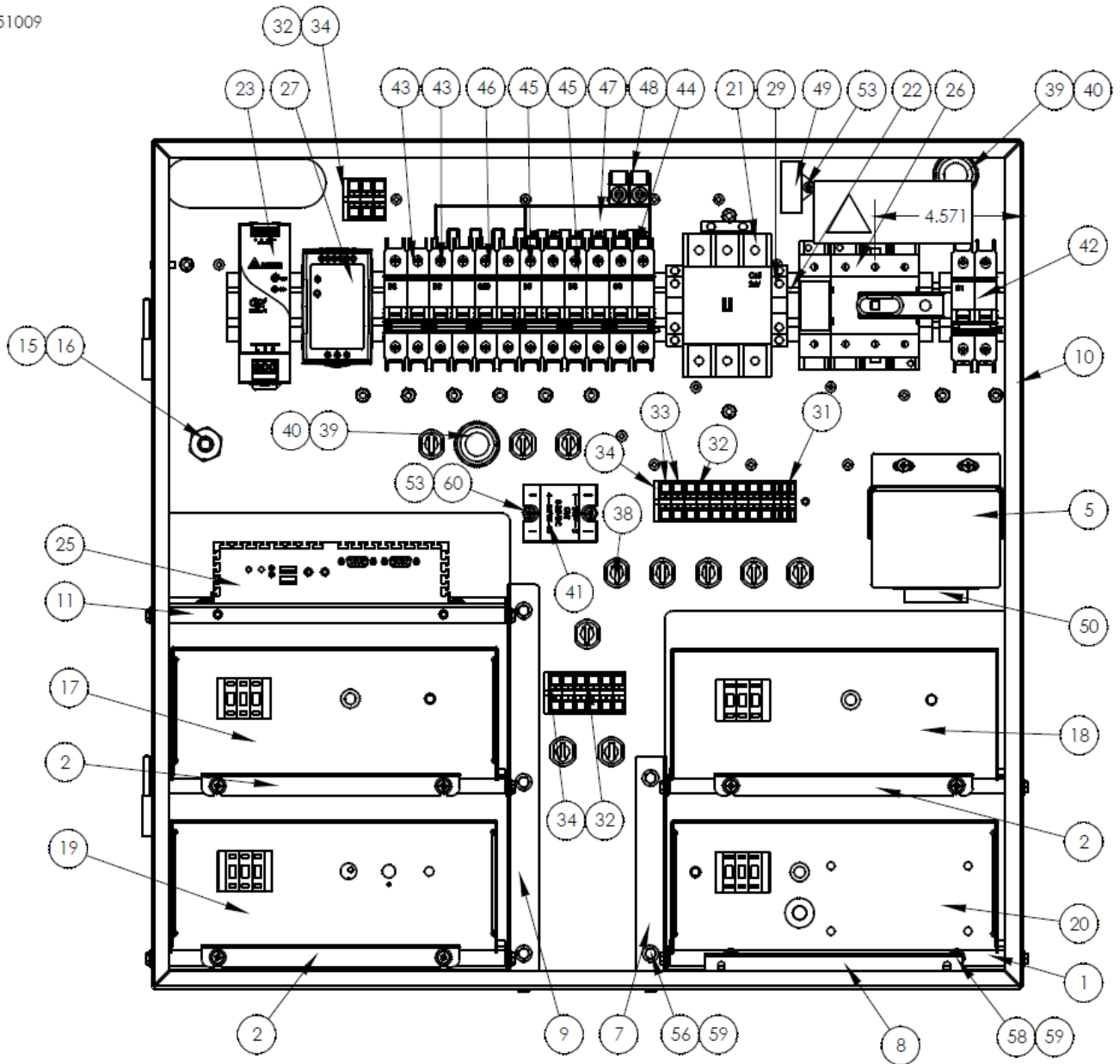

13351109 parts list

ITEM NO.	QTY.	PART NUMBER	DESCRIPTION
1	4	0411-1503	SHELF MOTOR BOX
2	3	0411-1505	BRKT,STEPPER BOX
3	1	001020	LABEL, Z535, WARNING
4	1	1335BP-WD2	DIAGRAM,WIRING,POWER
5	1	3210159	COVER, TRANSFORMER
6	1	13351022	DOOR WELDMENT
7	1	13351024	BRACE, RIGHT SIDE
8	1	13351027	BRKT,STEPPER BOX
9	1	13351115	BRACE, LEFT SIDE
10	1	13351116	BOX CHASSIS, PLC
11	1	13351117	SHELF MOTOR BOX
12	1	13351118	WAGO COVER
13	1	13351119	WAGO COVER, TOP
14	1	13351120	CABLE SET, 13351109
15	1	AAQBC-4-4	BULKHEAD CONN,1/4QUICK
16	1	AAXMLP100PD730	SENSOR, AIR-ELEC 0-100 PSI
17	1	AP-28-800C3	BOX,STEPPER,NO JOG
18	1	AP-28-800GG	BOX, STEPPER, DUAL 2A, SBUS
19	1	AP-28-800Y1A	BOX,STEPPER,H.S. (X5),2A,J,D,E
20	1	AP-28-820D	CONTROL BOX, STEP,10A
21	1	EECGC85A24	CONTACTOR,65A,24VAC
22	10	EECLIPFIX	ANCHOR,DIN RAIL
23	1	EEDRP24V100W	POWER SUP,SW,24V 3.8A, DIN
24	1	EEHR65	DISCONNECT HANDLE
25	1	EEJBC375C	COMPUTER,4G RAM,120SSD
26	1	EEM60U3M	DISCONNECT, 3PH, 60A, UL98
27	1	EEMDR10012	SUPPLY,SWR,12V 7.5A,85-264 IN
28	1	EESPA210-4.80	DISCONNECT SHAFT,MOD
29	1	EETS35X7.5A	DIN RAIL-AMERICAN
30	1	EETS35X7.5A	DIN RAIL-AMERICAN
31	3	FF264-311	TERMBLK,WAGO,TOP,SINGLE,GRY
32	15	FF264-341	TERMBLK,WAGO,TOP,DUAL,GRY
33	3	FF264-347	TERMBLK,WAGO,TOP,DUAL,GRN
34	3	FF264-371	TERMBLK,WAGO,TOP,END
35	1	FF280-319	TERMBLK,WAGO,SENSOR,DIN
36	48	FF280-402	JUMPER,WAGO,TOP,SNGL
37	25	FF280-560	TERMBLK,WAGO,SENSOR,DIN
38	11	FF1724	STRAIN RELIEF
39	2	FF3234	STRAIN RELIEF,3/4NPT
40	2	FF8465	NUT,LOCK, 3/4NPT,NYLON,BLK
41	1	FFD2425F	RELAY,SSR,24VAC,25A
42	1	FFFAZD12NA	BREAKER,2P,1A,UL489,240VT-MAG
43	2	FFFAZD22NA	BREAKER,2P, 2A,UL489,240VT-MAG
44	1	FFFAZD32NA	BREAKER,2P,3A,UL489,
45	2	FFFAZD52NA	BREAKER,2P,5A,UL489,
46	1	FFFAZD202NA	BREAKER,2P,20A,UL489,
47	2	FFM9XUP206	BREAKER,ACC,UL489,COMB,18MM,2P6
48	2	FFM9XUPC04	BREAKER,ACC,UL489,COMB,18MM,TOP
49	1	FFRAV781BW	MODULE, TVS, 240 VAC
50	1	FFTX28	TRANSFORMER,24V,2.4AMP
51	1	MMELH-1	LATCH, 1/4 TURN, SLOTTED
52	12	NNK10-32	KEP NUT, 10-32
53	3	SSBC90024	8-32X3/8 BUTTON CAP
54	6	SSBC98016	10-32 X 1/4 BUTTON CAP SC
55	16	SSFC80016	SCR,FLAT HD,CAP,6-32 X 1/4
56	25	SSHC98024	10-32 X 3/8 HEX CAP
57	4	SSPP90024	8-32X3/8 PAN PHLPS
58	12	SSPP98024	10-32 X 3/8 PAN HD PHILIP
59	37	WWFS10	WASHER, FLAT, #10, SAE
60	2	WWSB8	WASHER,BELVEL,#8

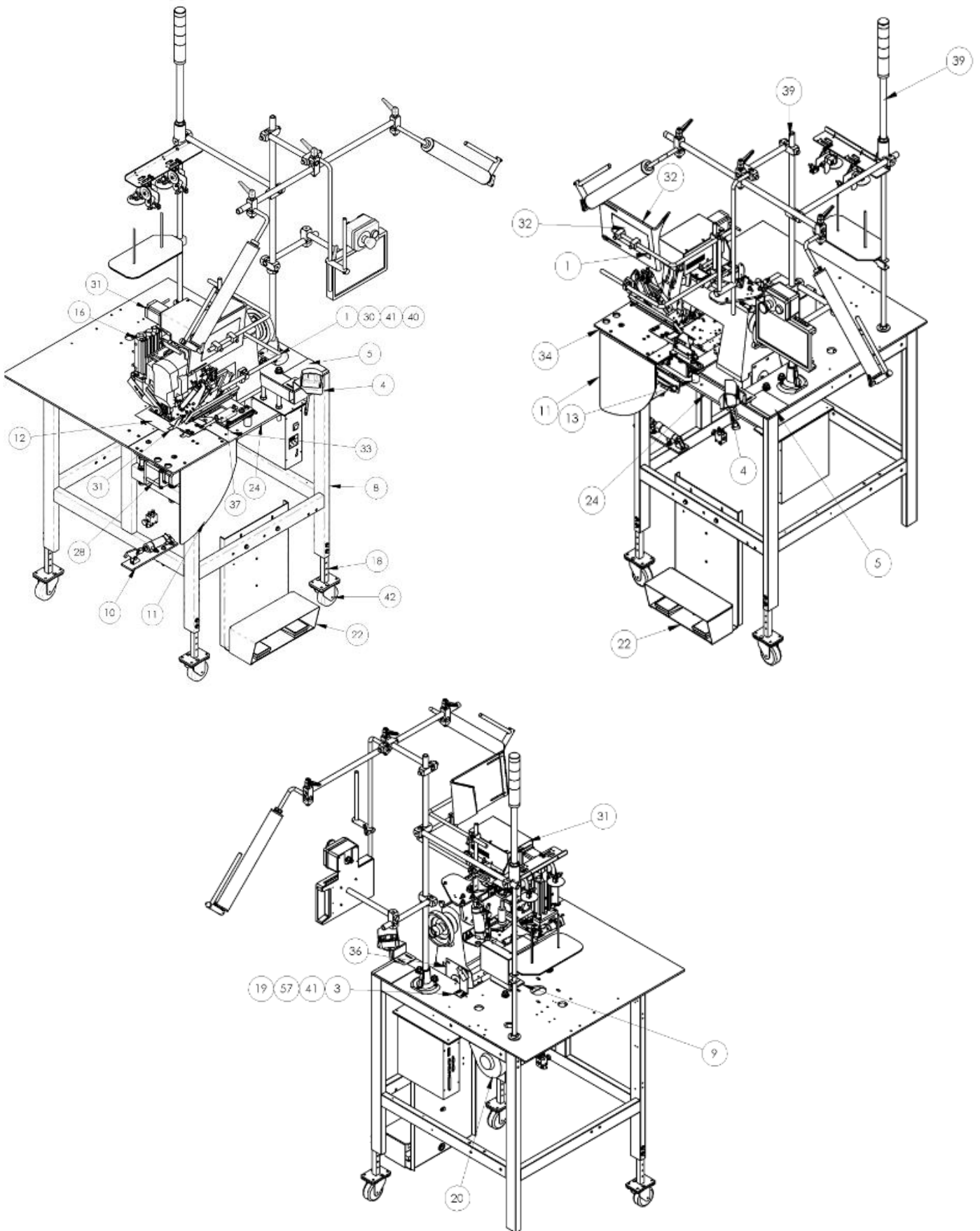

13351110 parts list

ITEM	QTY.	PART NUMBER	DESCRIPTION	ITEM	QTY.	PART NUMBER	DESCRIPTION
1	2	780-102C	ROD, BENT, 12 X 12 X 90DEG	38	1	13351107	CABLE PACKAGE, 13351111
2	1	1278-6602	TOUCH SWITCH ASSY	39	1	13351108	THREAD STAND ASSY, 1335B,
3	1	1278-6689B	BRACKET, EYE MOUNT	40	2	A-U	ROD CROSS BLOCK
4	1	1278-6718A	BRKT, OPTO TOUCH SWITCH	41	2	FFSM312LVQ	EYE, ELECTRIC, 10-30VDC
5	1	1309-LAB5	LABEL, Z535, WARNING	42	3	MM427-3RB	CASTER, SWIVEL, 3" RUBBER
6	1	1325-346	HOLDER, ROD, 1/2 D, SLOT MNT	43	2	MM1676A12	MAGNETIC CATCH
7	2	1335-006	BUTTON	44	24	NNJ1/2-20	NUT, JAM, 1/2-20
8	1	1335-100	FRAME, RUFFLER CONSOLE	45	2	NNK1/4-20	NUT, KEP, 1/4-20
9	1	1335-120	PULLER DRIVE ASSY	46	4	NNK10-32	KEP NUT, 10-32
10	1	1335-139	CLAMP & SWITCH ASSY 1335	47	2	SSBC05032S	1/4-28 X 1/2 BUT CAP SC
11	1	1335-174	BRACKET, SHELF	48	3	SSFC01048	1/4-20 X 3/4 FLAT CAP
12	1	1335-402	EXTENSION, TABLE TOP	49	4	SSFC98024	#10-32 X .375 FLAT CAP
13	4	1335-406A	MOUNT ISOLATOR, 1.60 H	50	4	SSFC98048	#10-32 X .75 SHCSF
14	1	1335-407	PLATE MOUNTING SEWING HEAD	51	12	SSHC01040	1/4-20 X 5/8 HHCS
15	4	1335-408	STUD, THREADED, 1/4-20	52	8	SSHC01048	1/4-20 X 3/4 HEX CAP
16	1	1335A-10B	SEWING HEAD ASSY, 300U X5	53	4	SSHC01064	1/4-20 X 1 HHCS
17	1	1335M-2002D	BLADE, RUFFLER, 10TPI	54	2	SSHC01096	1/4-20 X 1-1/2 HHCS
18	3	1961-115	LEG WELDMENT	55	2	SSHC01144	HEX HEAD, 1/4-20 X 2-1/4
19	1	1975-412A	PLATE, NUT, 4-40, .95CTC	56	3	SSHC10064	5/16-18 X 1 HHCS
20	1	4059-DC50	MOTOR, L/S, HIGH TORQ	57	2	SSPS70048	4-40 X 3/4 PAN HD SLOTTED
21	1	8732-0576	ROD, STRAIGHT, SS, 1/2 X	58	8	SSPS80016	#6-32 X 1/4 LG PAN HD
22	1	132556-011	DUAL FOOT PEDAL ASSY	59	2	SSSC01024	1/4-20 X 3/8 SOC CAP SC
23	1	132556-141A	BRACKET, TABLE, LEFT	60	2	SSSC98024	10-32 X 3/8 SOC CAP
24	1	132556-144B	PLATE MOUNTING	61	4	SSSC98032	10-32X1/2, SOC CAP
25	2	132556-145	ROD, THDED, 1/2-20X5.75	62	4	SSSCM6X30	M6X30 SOC CAP SCREW
26	4	132556-145A	ROD, THDED, 1/2-20X8.5	63	2	TTCL1BPPK1	KNOB, PLASTIC, #10-24
27	2	132556-149A	PLATE, LATCH 132556-400A	64	24	WWFS1/2	WASHER, FLAT, 1/2, SAE
28	1	132556-500C	EDGE GUIDE ASSY 1335	65	32	WWFS1/4	WASHER, FLAT, SAE, 1/4
29	1	132556-520	EDGE GUIDE EYE ASSY	66	3	WWFS5/16	WASHER, FLAT, SAE, 5/16
30	1	265155A	HOLDER, EYE, 1/2 BORE	67	8	WWFS6	WASHER, FLAT, #6
31	1	1335294A	RUFFLER ASSY, 11335MH-G	68	12	WWFS10	WASHER, FLAT, #10, SAE
32	1	1335780	ADJ FLANGE FOLDER, 8.5"	69	24	WWL1/2	1/2 LOCK WASHER
33	1	13351004	EDGE GUIDE, PANEL	70	16	WWL1/4	WASHER, LOCK, 1/4
34	1	13351006	TABLE TOP, FRONT	71	3	WWL5/16	WASHER, LOCK, 5/16
35	1	13351008	EFKA C/B ADAPTOR	72	2	WWL10	WASHER, LOCK, #10
36	1	13351066	BELT GUARD, 1335B	73	4	WWU5/8	WASHER, URETHANE
37	1	13351069	STRIPPER BLADE ASSY	74	1	ZX3832	V-BELT, 3/8 X 32

1335-139 CLAMP AND SWITCH ASSEMBLY

AAC Drawing Number 192468C Rev 0

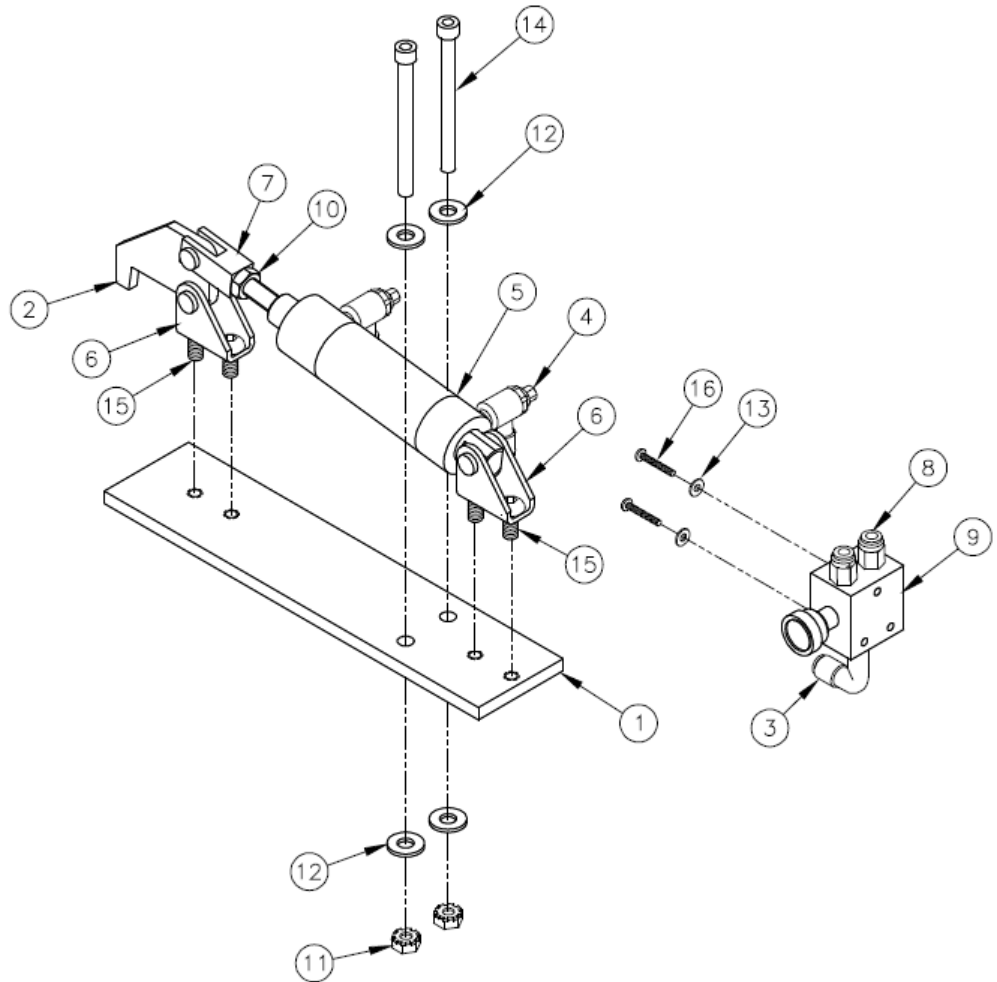

2	16	SCREW, PAN HD SLOTTED 6-32 x 1 1/4	SSPS80080
4	15	SCREW, BUTTON CAP 1/4-20 x 1/2	SSBC01032
2	14	SCREW, SOCKET CAP 1/4-20 x 2 3/4	SSSC01176
2	13	SAE FLAT WASHER	WWFS6
4	12	SAE FLAT WASHER	WWFS1/4
2	11	KEP NUT	NNK1/4-20
1	10	JAM NUT	NNJ5/16-24
1	9	VALVE	AAVMB43
2	8	QUICK MALE CONN.	AAQMC-5-8
1	7	CLEVIS	AAFCT-11
2	6	BRKT, PIVOT	AAFBP-11C
1	5	CYLINDER	AAC6DP-1
2	4	FLOW, CONTROL	AA198RA508
1	3	QUICK MALE ELBOW	AAQME-5-8
1	2	LATCH, AIR LOCK	1335-133
1	1	PLATE	1335-131
QTY. REQD.	ITEM NO.	DESCRIPTION	PART NO. STOCK SIZE

1335A-10B SEWING HEAD ASSY,300UX5

AAC Drawing Number 9001052 Rev 5

192128A

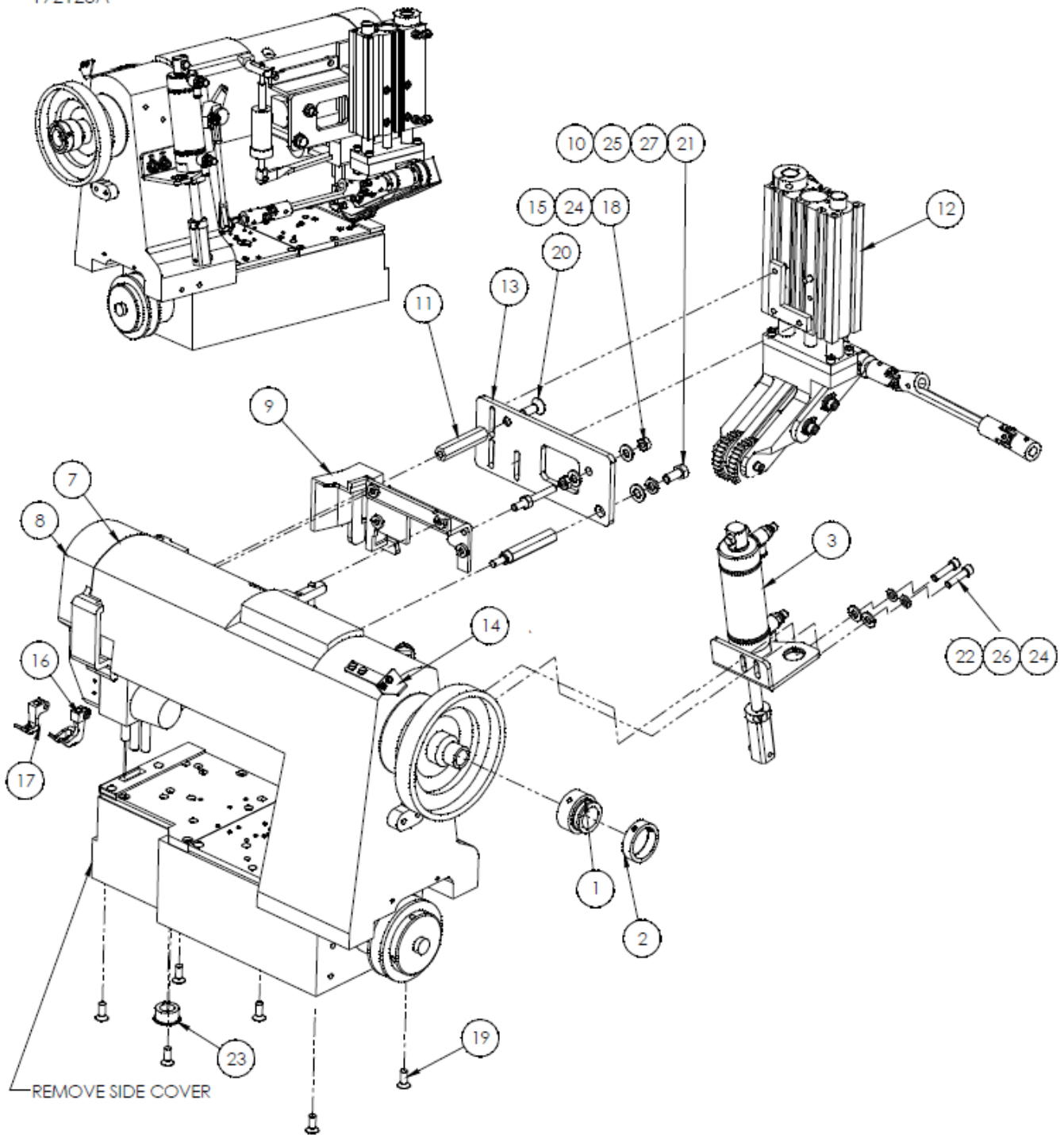

1335A-10B parts list

ITEM NO.	QTY.	PART NUMBER	DESCRIPTION
1	1	311-128	HUB, HANDWHEEL, TAPE MOUN
2	1	311-129	SLEEVE TAPE MOUNT ADJUST
3	1	1335-110B	FOOTLIFT ASSY.
4	1	1335-403C	BED PLATE, LEFT, MOD
5	1	1335-404	PLATE, THROAT
6	1	1335-405A	PLATE, BED, RIGHT, RUFFLE
7	1	1335Q-10M2	SEWING HEAD, MODIFIED
8	1	160505B	COVER,END, MOD.
9	1	1335051	Cover, Rear
10	1	1335054A	Standoff, Puller Plate
11	1	1335055A	Standoff, Puller Plate
12	1	1335140B	PULLER ASSY,300UX5 SINGER
13	1	1335412	PLATE, PULLER MNT, 1335MS
14	1	13351068	THREAD GUIDE, RUFFLER
15	1	AP-1883	Rod, Threaded
16	1	M1T31-052A	FOOT, HOLDING, RUFFLER
17	1	M1T31-052B	FOOT, WALKING, RUFFLER
18	3	NNH1/4-20	NUT,HEX,1/4-20
19	6	SSFC01040	1/4-20 X 5/8 FLAT ALN CAP
20	1	SSFC10056	5/16-18 X 7/8 FLAT HD CAP
21	1	SSHC10048	5/16-18 X 3/4 HHCS
22	2	SSSC01064	1/4-20 X 1 SOC CAP
23	1	TA2351004-R0	RUBBER PLUG
24	4	WWFS1/4	WASHER,FLAT,SAE,1/4
25	1	WWFS5/16	WASHER,FLAT,SAE,5/16
26	2	WWL1/4	WASHER,LOCK, 1/4
27	1	WWL5/16	WASHER,LOCK, 5/16

1335140 PULLER ASSEMBLY

AAC Drawing Number 9000449 Rev 2

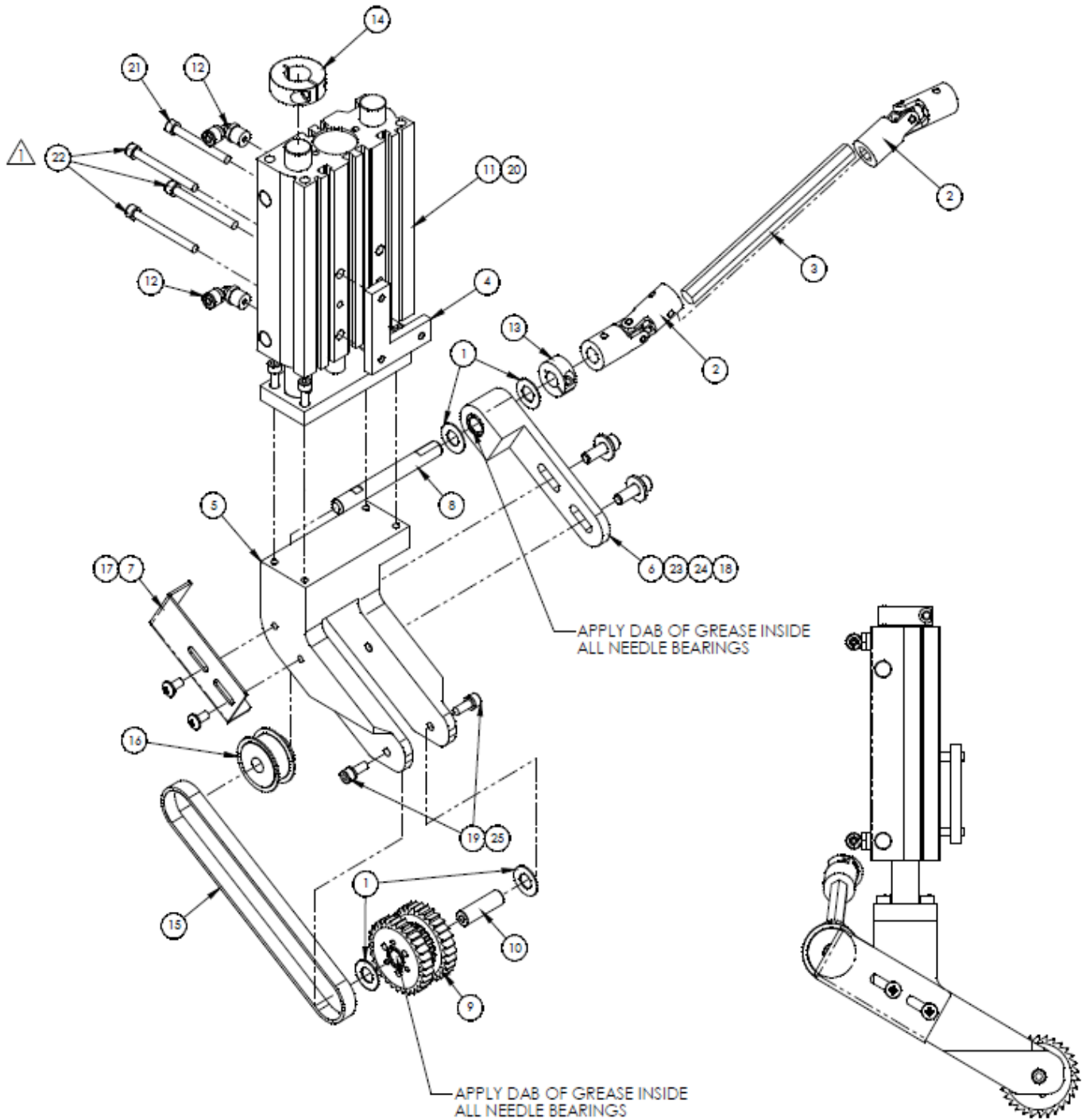

1335A-10B parts list

ITEM NO.	QTY.	PART NUMBER	DESCRIPTION
1	4	3517	WASHER,THRUST,BRONZE
2	2	3524-06A	U-JOINT,MODIFIED
3	1	3524-6352	SHAFT,3/8 HEX,5.50L
4	1	1335053A	PLATE,NUT,"L",10-32,3 PL
5	1	1335134	YOKE,PULLER,CENTER DRIVE
6	1	1335143	SUPPORT, DRIVE
7	1	1335449	BELT GUARD,
8	1	1335540	DRIVE SHAFT, TOP
9	1	1335743	PULLER ROLLER ASSEMBLY
10	1	1335748	SHAFT, PULLER, IDLER
11	1	AACMGPM25100	CYLINDER,AIR,GUIDED
12	2	AAQME-M4-8	QUICK MALE ELBOW
13	1	CCCL6F	CLAMP COLLAR- 3/8
14	1	CCCL10F	CLAMP COLLAR- 5/8 ID
15	1	GG150XL037U	BELT,GEAR,1/5P,3/8W
16	1	PP18XL037M	PULLEY,GEAR,1/5P,18T,3/8B
17	2	SSPP98024	10-32 X 3/8 PAN HD PHILIP
18	2	SSSC01048	1/4-20 X 3/4" SOC CAP SC
19	2	SSSC98032	10-32X1/2, SOC CAP
20	4	SSSC98048	10-32 X 3/4 SOC CAP
21	1	SSSC98112	SCR, SOC CAP 10-32 X 1-3/4
22	3	SSSC98128	10-32 X 2 SOC CAP
23	2	WWFS1/4	WASHER,FLAT,SAE,1/4
24	2	WWL1/4	WASHER,LOCK, 1/4
25	2	WWL10	WASHER,LOCK,#10

1335-120 PULLER DRIVE ASSEMBLY

AAC Drawing Number 192446C Rev 4

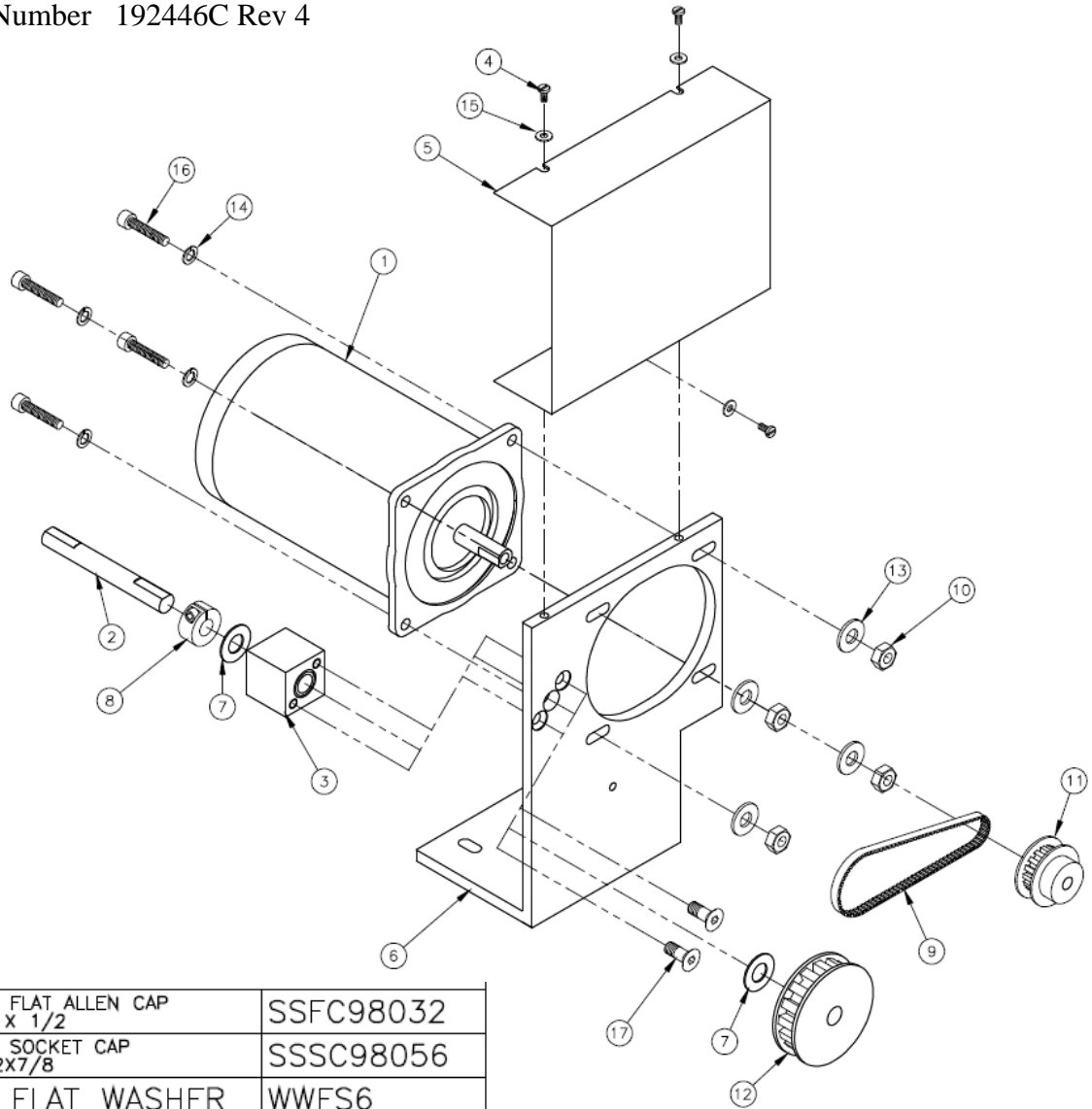

2	17	SCREW, FLAT ALLEN CAP 10-32 x 1/2	SSFC98032
4	16	SCREW, SOCKET CAP 10-32x7/8	SSSC98056
3	15	SAE FLAT WASHER	WWFS6
4	14	LOCK WASHER	WWL10
4	13	SAE FLAT WASHER	WWFS10
1	12	PULLEY, GEAR	PP32AXL037M
1	11	PULLEY, GEAR	3554-5
4	10	HEX NUT	NNH10-32
1	9	BELT, GEAR	GG100XL037
1	8	CLAMP COLLAR	CCCL6F
2	7	WASHER, THRUST	3517
1	6	MOUNT, MOTOR	1335-125
1	5	GUARD	1335-124
3	4	SCREW, PAN HD SLOTTED 6-32 x 3/8	SSPS80024
1	3	BLOCK, BEARING	1335-119
1	2	SHAFT	1335-116
1	1	STEP MOTOR	011-020
QTY. REQD.	ITEM NO.	DESCRIPTION	PART NO. STOCK SIZE

132556-500C EDGE GUIDE ASSEMBLY

AAC Drawing Number 192855C Rev 0

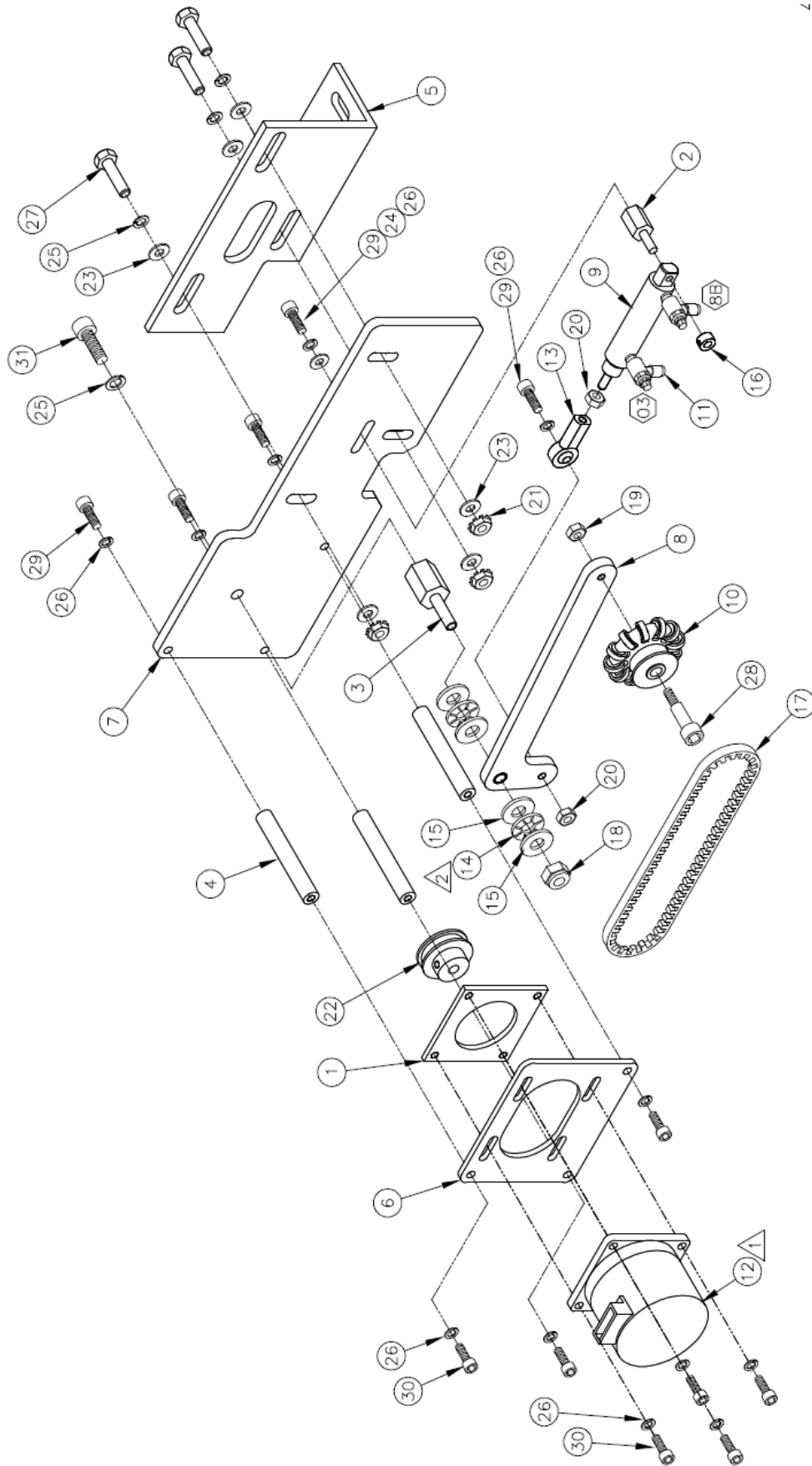

132556-500 parts list

1	31	SCREW, SOCKET CAP 1/4-20 X 3/4	SSSC01048	1	16	COLLAR, SET	CCSC33/16
7	30	SCREW, SOCKET CAP 10-32 X 1/2	SSSC98032	4	15	WASHER, THRUST	BBTRA411
5	29	SCREW, SOCKET CAP 10-32 X 3/4	SSSC98048	2	14	BEARING, THRUST	BBNTA411
1	28	SCREW, ALLEN SHOULDER 1/4 X 1, 10-24	SSAS016064	1	13	ROD END	BBAW-3Z
3	27	SCREW, HEX HEAD CAP 1/4-20 X 1	SSHC01064	1	12	STEP MOTOR	AP-22E-104
12	26	LOCK WASHER	WWL10	2	11	REV. FLOW CONT.	AA198RR510
4	25	LOCK WASHER	WWL1/4	1	10	GUIDE WHEEL ASSY.	40-630
1	24	SAE FLAT WASHER	WWFS10	1	9	AIR CYLINDER	1975-213
6	23	SAE FLAT WASHER	WWFS1/4	1	8	ARM, PIVOT	132556-513
1	22	GEAR PULLEY	PP40DF1808	1	7	PLATE, GUIDE	132556-512
3	21	KEP NUT	NNK1/4-20	1	6	MOUNT, MOTOR	132556-511
2	20	HEX NUT	NNH10-32	3	4	ANGLE, GUIDE MTNG.	132556-510
1	19	HEX NUT	NNH10-24	1	3	STANDOFF	12787-1634
1	18	NUT, ELASTIC	NEE1/4-20	1	2	STANDOFF	12787-1632
1	17	BELT, GEAR	GG6R195018	1	1	STANDOFF	12787-1620
QTY. RECD.	ITEM NO.	DESCRIPTION	PART NO. STOCK SIZE	QTY. RECD.	ITEM NO.	DESCRIPTION	PART NO. STOCK SIZE

132556-520 EDGE GUIDE EYE ASSEMBLY

AAC Drawing Number 192507B Rev 0

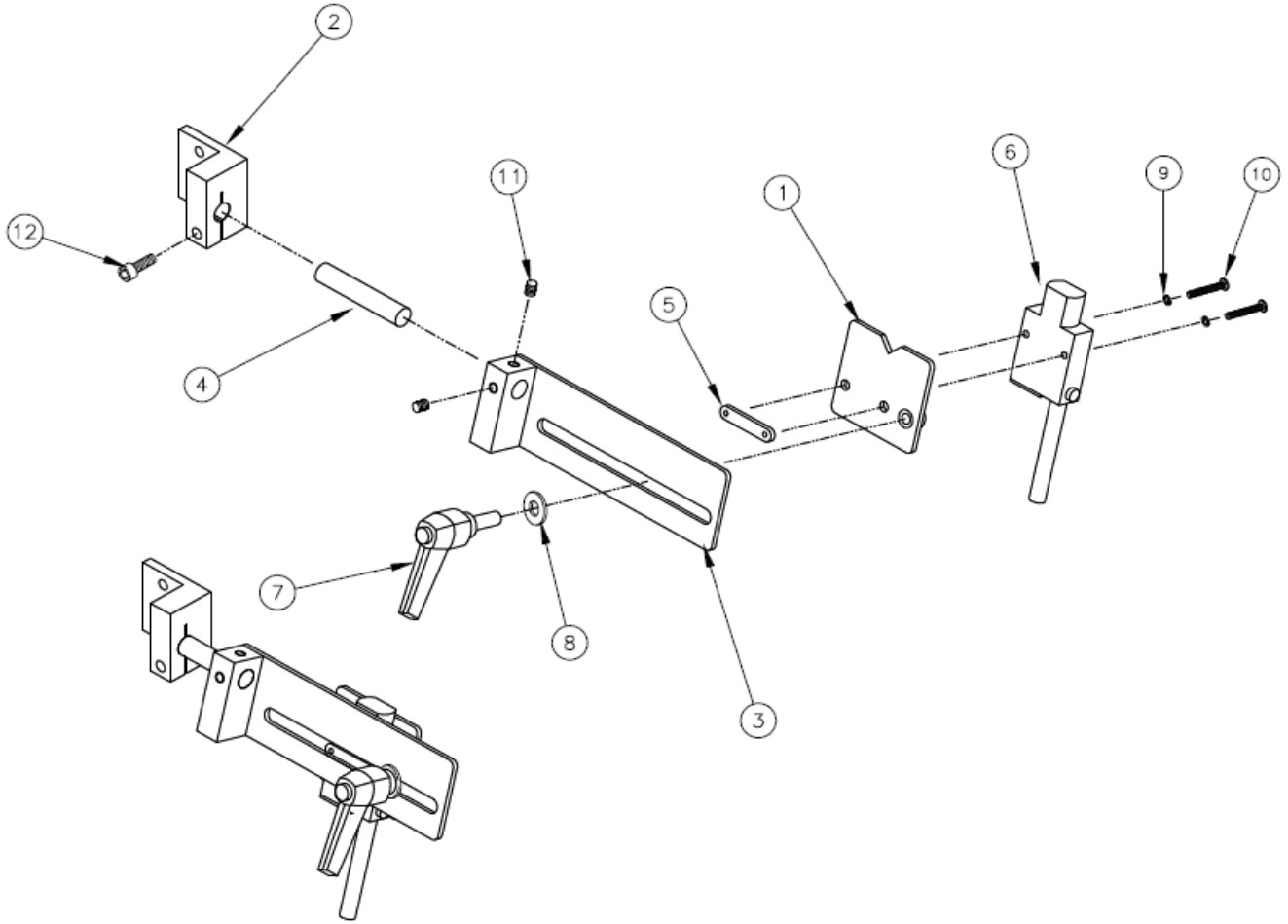

AR	13	LABEL	132556-521
1	12	SCREW, SOCKET CAP 10-32 X 3/4	SSSC98048
2	11	SCREW, SOCKET SET 10-32 X 1/4	SSSS98016
2	10	SCREW, PAN HD SLOTTED 4-40 X 3/4	SSPS70048
2	9	WASHER, LOCK	WWL4
1	8	SAE FLAT WASHER	WWFS1/4
1	7	HANDLE, THREADED	TTH32415
1	6	EYE	FFSM312LVQ
1	5	PLATE, NUT	1975-412A
1	4	ROD, 3/8 X 1.85	3515B-015D
1	3	MOUNT, ROD	132556-519
1	2	MOUNT, ROD	132556-518
1	1	PLATE, EYE MNT	132556-517
QTY. REQD.	ITEM NO.	DESCRIPTION	PART NO. STOCK SIZE

1335780 ADJ FLANGE FOLDER,8.5"

AAC Drawing Number 1335780 Rev 0

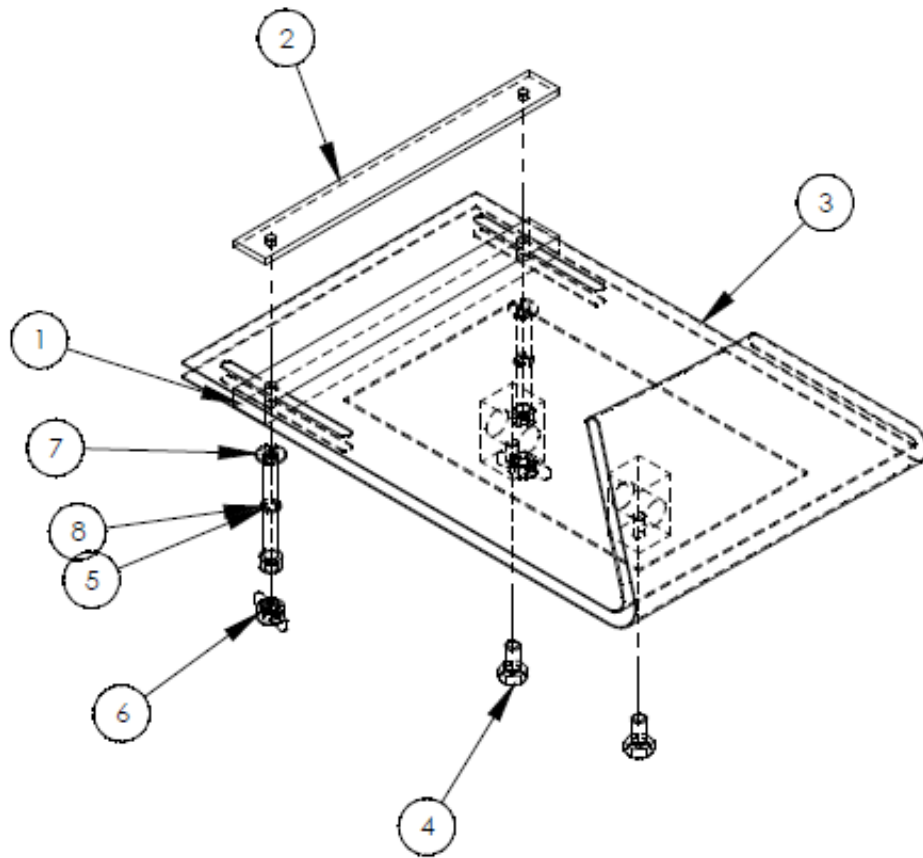

ITEM NO.	QTY.	PART NUMBER	DESCRIPTION
1	1	1335565	SPACER, FOLDER
2	1	1335567	PLATE,NUT,10-32 X 2
3	1	1335769	FLANGE FOLDER MNT ASSY
4	2	SSH01032	1/4-20 X 1/2 HEX HEAD
5	2	PreviewCfg	
6	2	SSW#10	WING SCREW KNOB
7	2	WWFS10	WASHER, FLAT #10
8	2	WWL10	#10 LW

192096A

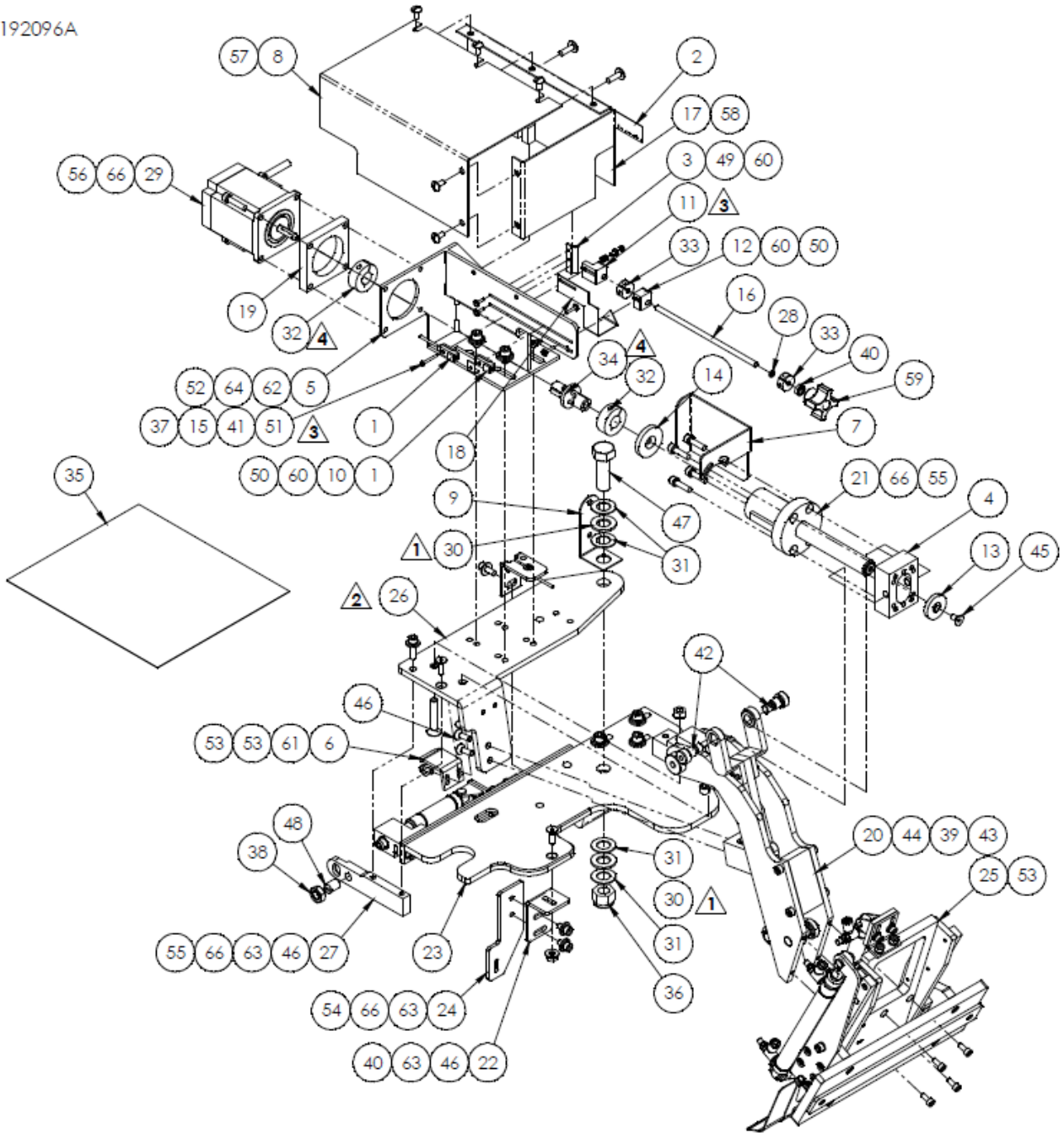

1335294A parts list

ITEM NO.	QTY.	PART NUMBER	DESCRIPTION	ITEM NO.	QTY.	PART NUMBER	DESCRIPTION
1	2	1278-7055D	PROX SWITCH W/PLUG,12"	34	1	MM8FM	JOINT,UNIVERSAL,MOD
2	1	1325-4126	LABEL, SCALE, METRIC	35	*1	MM130-10A7	TAPE,TEFLON,7 WIDE
3	1	1335M-001	BRACKET, STOP, PRX SWITCH	36	1	NNE1/2-13	NUT, ELASTIC 1/2-13
4	1	1335M-2006	BLOCK, NUT TRUNION	37	1	NNH2-56	#2-56 HEX NUT
5	1	1335M-2016	MTG BRKT WELDT	38	1	NNJ3/8-16	3/8-16 HEX JAM NUT
6	1	1335M-2020	HLD DWN BRKT	39	1	NNK1/4-20	KEP NUT, 1/4-20
7	1	1335M-2021	VANE, SWITCH ACTUATING	40	2	NNK10-32	KEP NUT, 10-32
8	1	1335M-2030	MOTOR COVER, CLEAR	41	1	RRLC026B1	SPRING,COMP .026X.18X.25
9	1	1335M-2031	PIVOT BRKT AIR LINE	42	2	SSAS024024M	3/8 X 3/4 X 5/16-18
10	1	1335M-2034	PLATE, NUT #2-56	43	1	SSFC01040	1/4-20 X 5/8 FLAT ALLEN
11	1	1335M-2035	ADJUSTMENT NUT, 10-32	44	1	SSFC01096	1/4-20 X 1-1/2 FLAT ALLEN
12	1	1335M-2036	SUPPORT BLOCK	45	1	SSFC98024	#10-32 X 3/8 FLAT ALLEN
13	1	1335M-2037	WASHER, STOP	46	4	SSFC98040	#10-32 X 5/8 FLAT ALLEN
14	1	1335M-2038	STOP WASHER	47	1	SSHHC45096	1/2-13 X 1 1/2 L HHCS
15	1	1335M-2039	NUT,SPRING RETAINER	48	1	SSMB58N	PLUNGER,BALL,3/8-16X5/8L
16	1	1335M-2040	SCREW, ADJUSTMENT	49	2	SSPS50024	2-56 X 3/8 PAN HD SC
17	1	1335M-2042	COVER	50	2	SSPS50032	#2-56 X 1/2 PAN HD SLOT
18	1	1335M-2047	POINTER, RUFFLE SIZE	51	1	SSPS50048	#2-56 X 3/4 PAN HD SLOT
19	1	1335M-2049	SPACER, MOTOR, 3/8	52	4	SSSC01024	1/4-20 X 3/8 SOC CAP SC
20	1	1335M-2300A	PIVOT ASSY	53	6	SSSC90024	8-32 X 3/8 SOC CAP SC
21	1	1335M-2400	BALL SCREW AND NUT	54	2	SSSC98024	10-32 X 3/8 SOC CAP
22	1	1335218	ADJ ANGLE-RUFFLER SUPP	55	5	SSSC98048	10-32 X 3/4 SOC CAP
23	1	1335298A	RUFFLER MTG ANGLE ASSY	56	4	SSSC98056	10-32 X 7/8 SOC CAP
24	1	1335323	SUPPORT BRKT-RUFFLER	57	5	SSTS90024	#8-32 X 3/8 TRUSS HD
25	1	1335332	RUFFLER CYL LIFT ASSY	58	2	SSTS98040	#10-32 X 5/8 TRUSS HD
26	1	1335410	PLATE, PIVOT, RUFFLER ASS	59	1	TTCL1APPK1	PLASTIC KNOB, #10-32
27	1	13351075	LOCKING LEVER	60	4	WWF2	WASHER, FLAT #2
28	1	AA198-7006	O RING, 1/8 ID, 1/4 OD	61	2	WWF8	WASHER, FLAT #8
29	1	AP-22E-103	STEP MOTOR, 2 AMP	62	4	WWFS1/4	WASHER FLAT, 1/4
30	2	BBNTA815	BEARING,THRUST,1/2BORE	63	4	WWFS10	WASHER, FLAT #10
31	4	BBTRA815	WASHER,THRUST,STEEL 1/2	64	4	WWL1/4	1/4 LW
32	2	CCCL8F	CLAMP COLLAR- 1/2	65	2	WWL8	#8 LW
33	2	CCCL10T	CLAMP COLLAR TRD, 10-32	66	12	WWL10	#10 LW

1335M-2300A PIVOT ASSEMBLY

AAC Drawing Number 9000972 Rev 4

NOTE: ALIGN ON BASE PLATE
TRANSFER 2 HOLES FOR ITEM 13

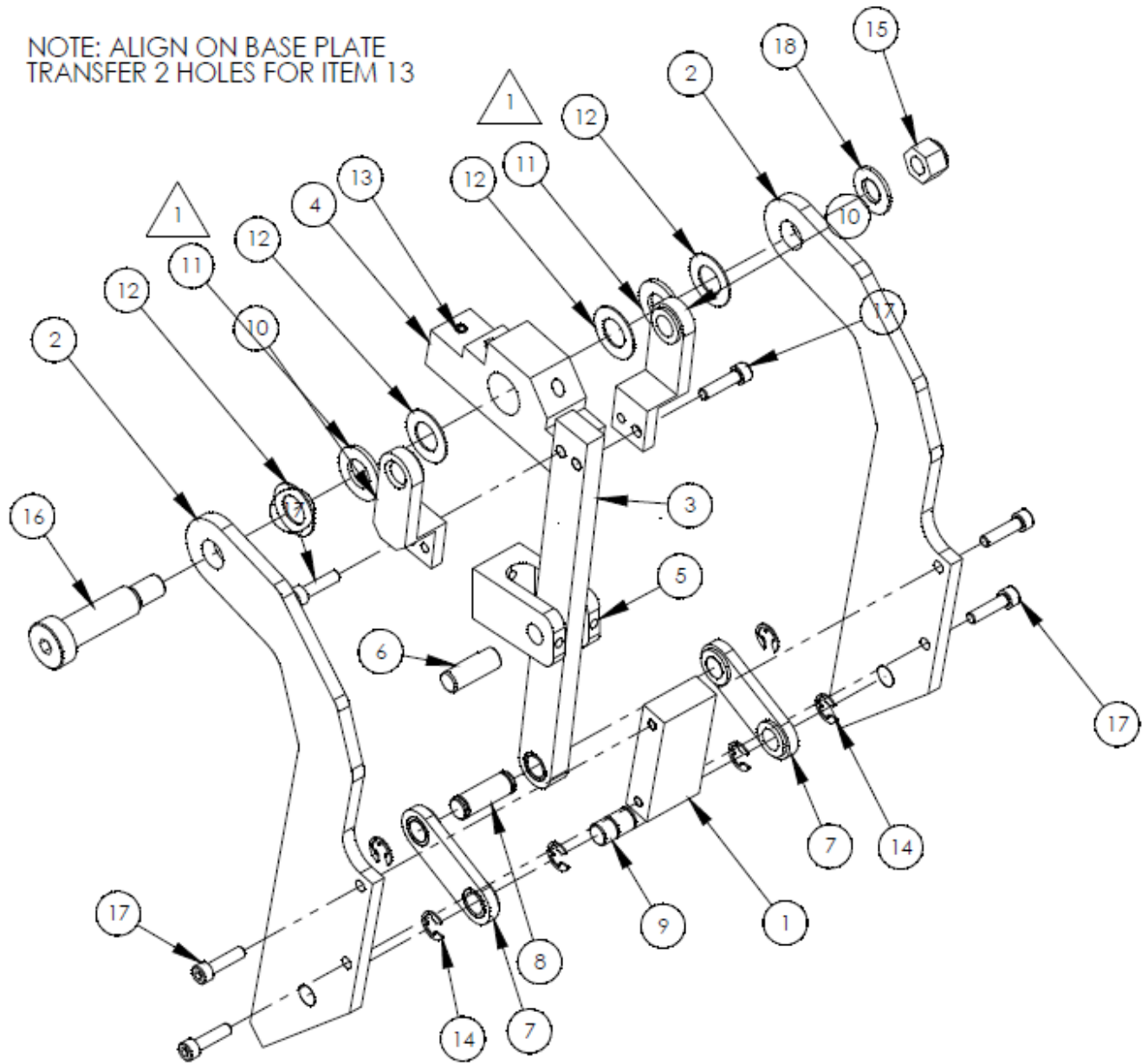

1335M-2300A parts list

ITEM NO.	Default/QTY.	PART NUMBER	DESCRIPTION
1	1	1335373	SPACER, RUFFLER PIVOT
2	2	1335409	PIVOT ARM
3	1	1335411	DRIVE LINK, 11335MH, 300U
4	1	1335M-2007	PIVOT BLOCK
5	1	1335M-2010	BLOCK, DRIVE LINK PIVOT
6	1	1335M-2011	PIVOT SHAFT
7	2	1335M-2012	SIDE LINK
8	1	1335M-2013	LINK SHAFT
9	1	1335M-2014	LINK SHAFT
10	2	1335M-2015	LINK YOKE
11	2	BBNTA815	BEARING,THRUST,1/2BORE
12	4	BBTRA815	WASHER,THRUST,STEEL 1/2
13	2	IIS012X064	SPRING PIN 3/16 DIA X 1LG
14	6	MM8407A134	RING,RETAINING,"E",3/8"
15	1	NNE3/8-16	NUT, ELASTIC 3/8-16
16	1	SSAS032096	SHOULDER BOLT 1/2 X .1.50
17	6	SSSC98048	#10-32 X 3/4 SOC CAP
18	1	WWFS3/8	WASHER, FLAT, 3/8

11335332 RUFFLER CYL LIFT ASSY

AAC Drawing Number 1335332 Rev 9

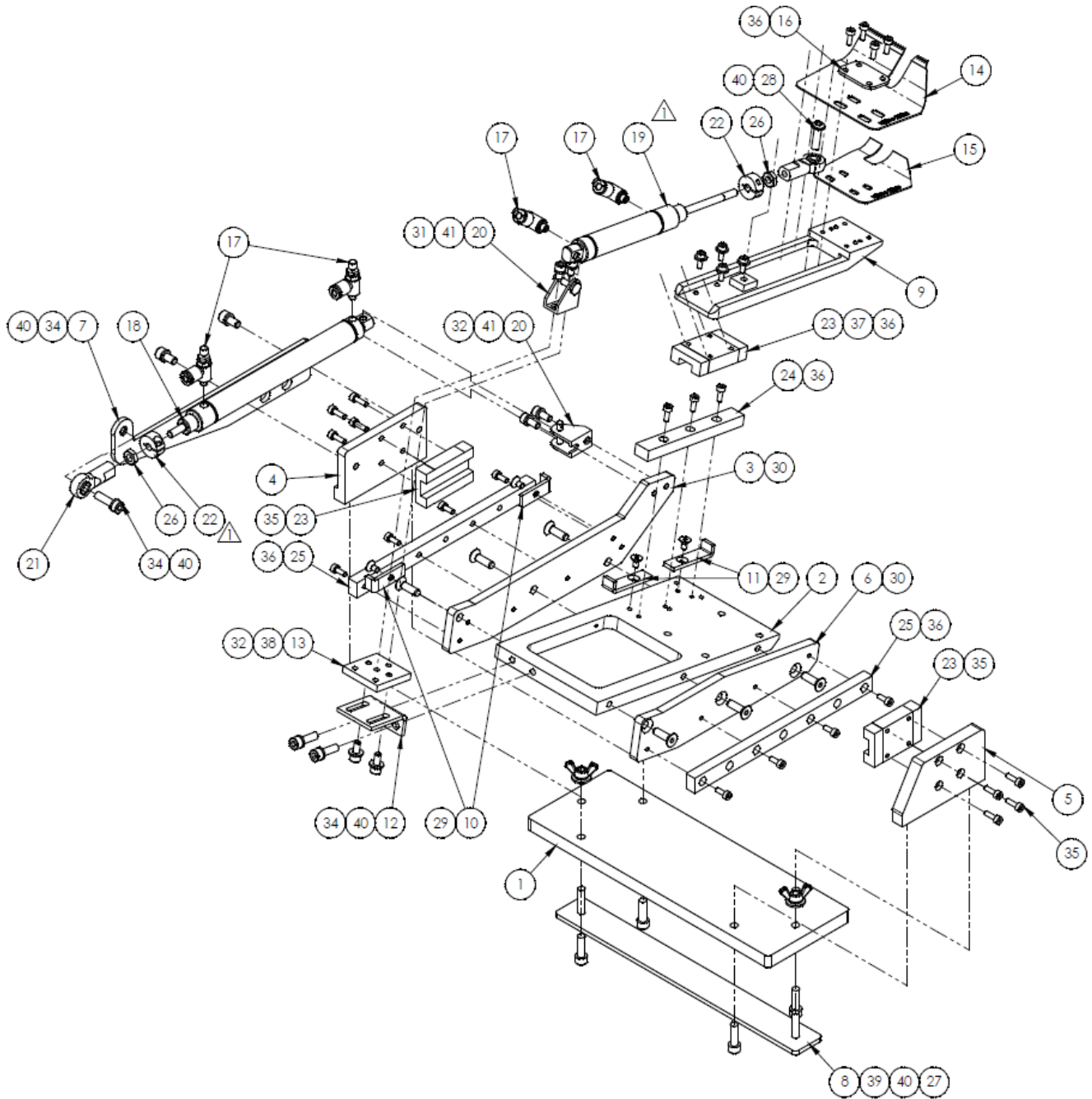

11335332 parts list

ITEM NO.	QTY.	PART NUMBER	DESCRIPTION
1	1	1335223	BASE MTG PLT, FOLDER
2	1	1335224	BASE MTG PLATE
3	1	1335226	MTG PLT LH- RAIL
4	1	1335227	SUPPORT-SLIDE, LH SIDE
5	1	1335228	SUPPORT, RH
6	1	1335229	MTG PLT RH- RAIL
7	1	1335230	FOLDER SLIDE ARM
8	1	1335235	STUD PLATE-YAMATO1804
9	1	1335335	MTG PLT- HEAVY DUTY
10	2	1335338	BRG STOP
11	2	1335775	BEARING STOP, LONG
12	1	1335776	CYL. MOUNTING ANGLE
13	1	1335777	CYL. MOUNTING PLATE
14	1	1335M-2002E	BLADE, RUFFLER, 2.25 X 12
15	1	1335M-2002F	BLADE, RUFFLER, 2.25 X 12
16	1	1335M-5004	PLATE, WASHER, 136DIA@4PL
17	4	AA198RA510	FL CONT,5/32X10-32
18	1	AAC024DXP	CYL,BIMBA,9/16 B,4 S
19	1	EXTENDED	CYL, AIR, DA, 9/16B, 2S
20	2	AAFBP-8C	BRKT,PIVOT,5/32 BORE
21	2	BBAW-3Z	BRG,ROD END,F, 10-32
22	2	CCCL3F	CLAMP COLLAR- 3/16
23	3	MMGN12H	MGN12H BEARING BLOCK
24	1	MMGNR12R0090HM	12MM X 90MM RAIL
25	2	MMGNR12R0165HM	165MM RAIL - MGN12H BLK
26	2	NNJ10-32	NUT,JAM,THIN #10-32
27	2	NNW10-32	#10-32 WING NUT
28	1	SSBC98040	10-32 X 5/8 BUTTON CAP SC
29	4	SSFC80016	SCR,FLAT HD,CAP,6-32 X 1/4
30	6	SSFC98040	#10-32 X 5/8 FLAT ALLEN
31	2	SSSC90016	#8-32 X 1/4 SOC CAP SC
32	4	SSSC90024	#8-32 X 3/8 SOC CAP SC
33	2	SSSC98024	10-32 X 3/8 SOC CAP
34	7	SSSC98040	10-32 X 5/8 SOC CAP
35	8	SSSCM3X10	M3-0.5X10, SOCKET CAP
36	19	SSSCM3X8	M3-0.5X8 ,SOCKET CAP
37	4	WWF4	WASHER, FLAT, #4
38	2	WWF8	WASHER, FLAT, #8
39	2	WWF510	WASHER, FLAT, #10, SAE
40	8	WWL10	WASHER,LOCK,#10
41	6	WWL8	WASHER,LOCK,#8

1335298A Ruffler Mount Assembly

AAC Drawing Number 9000931 Rev 5

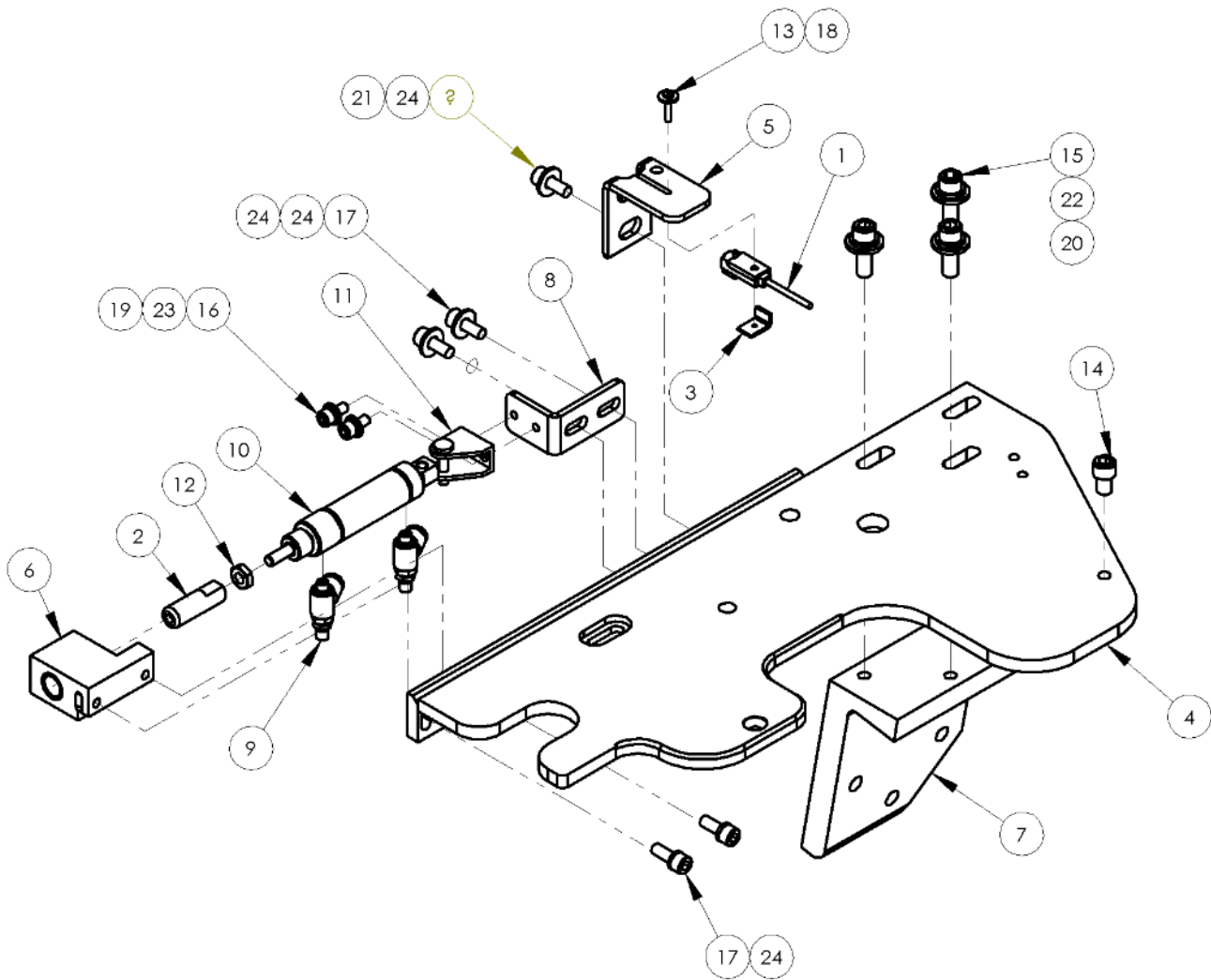

ITEM	QTY.	PART NUMBER	DESCRIPTION	ITEM	QTY.	PART NUMBER	DESCRIPTION
1	1	1278-7055D	PROX SWITCH W /PLUG,12"	13	1	SSPS50032	SCREW ,2-56 x 1/2
2	1	1335M-2017	ROD, END	14	1	SSSC01024	1/4-20 X 3/8 SOC CAP SC
3	1	1335M-2034	PLATE, NUT #2-56	15	3	SSSC01048	1/4-20 X 3/4" SOC CAP SC
4	1	1335315A	BASE PLATE, RUFFLER MTG	16	2	SSSC90024	8-32 X 3/8 SOC CAP SC
5	1	1335325	MTG. BRKT. SENSOR	17	5	SSSC98032	10-32X1/2, SOC CAP
6	1	1335334	CYL. MOUNT	18	1	WWF4	WASHER, FLAT, #4
7	1	1335401	REAR MOUNT, 1335MH	19	2	WWF8	WASHER, FLAT, #8
8	1	1335407	MNT BRKT,LOCK PIN CYL.	20	3	WWFS1/4	WASHER,FLAT,SAE,1/4
9	2	AA198RA510	FL CONT,5/32X10-32	21	3	WWFS10	WASHER, FLAT, #10, SAE
10	1	AAC8DP-.5	CYL,AIR,DA,9/16 B,1/2S	22	3	WWL1/4	WASHER,LOCK, 1/4
11	1	AAFBP-8C	BRKT,PIVOT,5/32 BORE	23	2	WWL8	WASHER,LOCK,#8
12	1	NNJ10-32	NUT,JAM,THIN #10-32	24	5	WWL10	WASHER,LOCK,#10

13351069 STRIPPER BLADE ASSEMBLY

AAC Drawing Number 13351069 Rev 1

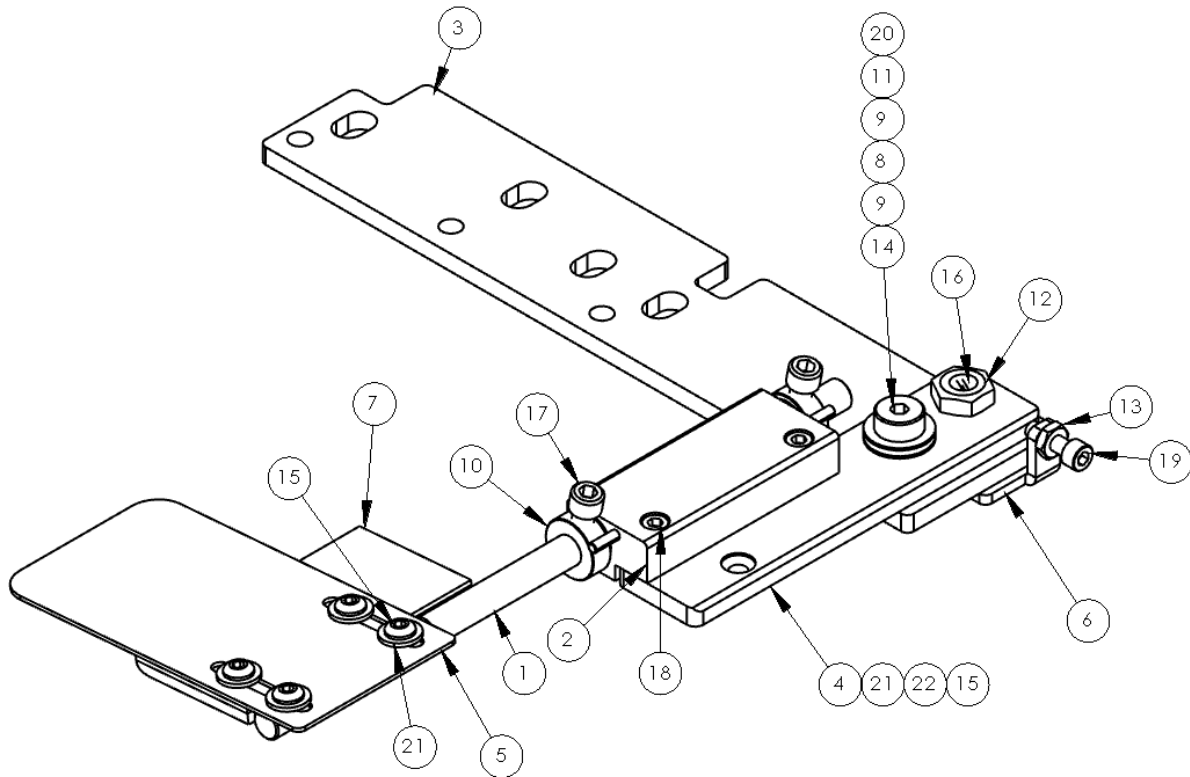

ITEM NO.	QTY.	PART NUMBER	DESCRIPTION
1	1	1335474	PIVOT ROD, STRIP BLADE
2	1	1335506	PIVOT BLOCK, STRIPPER BLADE
3	1	13351070	MOUNT, STRIPPER BLADE ASM
4	1	13351071	PIVOT PLATE, STRIP PLT
5	1	13351072	STRIPPER BLADE, EXTENDED
6	1	13351073	BACK STOP, ADJ, STRIPPER BLADE ASSEM
7	1	13351074	SLIDE BLOCK, STRIPPER BLADE
8	2	BBNTA613	BEARING,THRUST,375BORE
9	4	BBTRA613	WASHER,THRUST,STL, .375B
10	2	CCSC6F3/8	COLLAR,SET 3/8
11	1	NNE5/16-18	NUT,ELASTIC LOCK,5/16-18
12	1	NNJ3/8-16	3/8-16 JAM NUT
13	1	NNJ10-32	NUT,JAM,THIN #10-32
14	1	SSAS024048	SHOULDER BOLT,3/8X3/4X5/16-18
15	6	SSBC98024	10-32 X 3/8 BUTTON CAP SC
16	1	SSMB58N	PLUNGER,BALL,3/8-16X5/8L
17	2	SSSC01024	1/4-20 X 3/8 SOC CAP SC
18	2	SSSC98032	10-32X1/2, SOC CAP
19	1	SSSC98040	10-32 X 5/8 SOC CAP
20	1	WWFS5/16	WASHER,FLAT,SAE,5/16
21	6	WWFS10	WASHER, FLAT, #10, SAE
22	2	WWL10	WASHER,LOCK,#10

13351108 THREAD STAND ASSY, 1335B, PLC

AAC Drawing Number 13351108 Rev 0

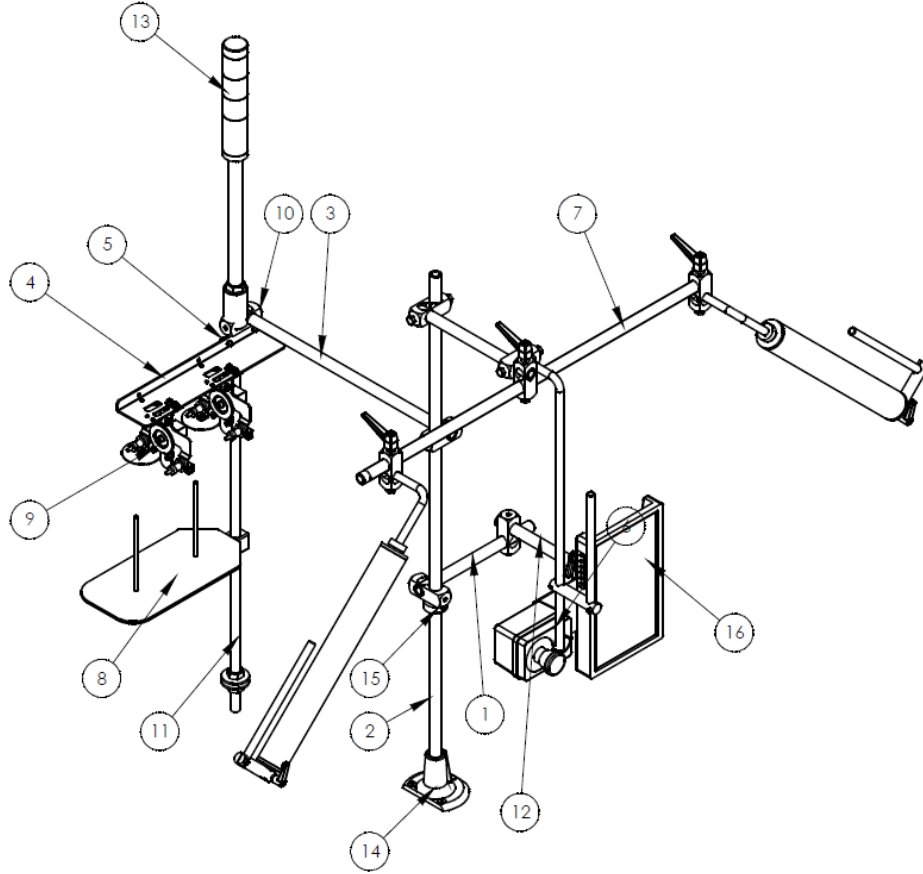

ITEM NO.	QTY.	PART NUMBER	DESCRIPTION
1	1	97-1711A	TUBE, 3/4 X 10 X 1/8 WALL
2	1	97-1711D	TUBE, 3/4 OD X 40.0L
3	1	97-1711J	TUBE, 3/4 X 20 X 1/8 WALL
4	1	0411-069D	BRKT, THREAD BREAK DETECT
5	1	0411-070	CLAMP, SENSOR BRACKET
6	1	1278-6010	START/STOP BUTTON ASSY
7	1	1335A-430	GUIDE ROLLER ASSY
8	1	1959-112	2 POS THREAD PLATE ASSY
9	2	4003-500C	THREAD BREAK SENSOR ASSY
10	4	28201	CONNECTOR, ROD, LARGE
11	1	4300056	POLE, THREAD STAND
12	1	13351060	MOUNT, 10" TOUCH SCREEN
13	1	13351125	LIGHT ASSEMBLY, PLC, 1335BP
14	1	AP-1721	STAND BASE, COMPLETE
15	1	CCCL12F	CLAMP COLLAR- 3/4
16	1	EEE10TSM	10" TOUCH SCREEN
17	2	NNH5/8-18	NUT, HEX, 5/8-18
18	4	SSPS90040	8-32 X 5/8 PAN HD
19	4	SSSC98024	10-32 X 3/8 SOC CAP
20	2	SSSC98040	10-32 X 5/8 SOC CAP
21	4	SSSCM3X10	M3-0.5X10, SOCKET CAP
22	2	WWF5/8	WASHER, FLAT, 5/8
23	6	WWFS10	WASHER, FLAT, #10, SAE
24	1	WWL5/8	WASHER, LOCK 5/8
25	2	WWL10	WASHER, LOCK, #10
26	4	WWLM3	WASHER, LOCK, M3

13351111 MAIN SOLENOID PANEL ASSY

AAC Drawing Number 13351111 Rev 1

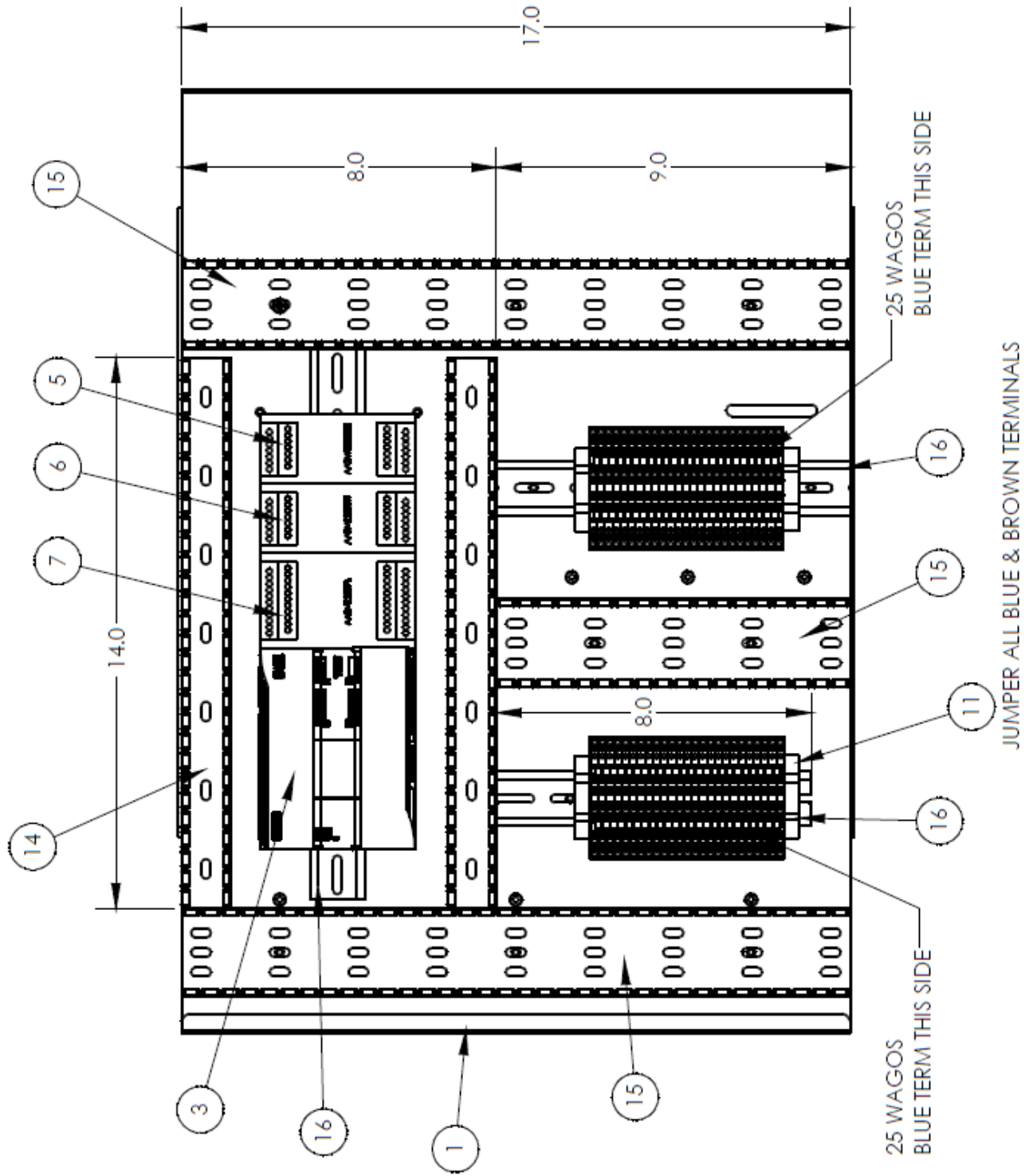

13351111 parts list

ITEM NO.	QTY.	PART NUMBER	DESCRIPTION
1	1	13351112	BOX PNEUMATIC
2	1	1335BP-WD1	WIRING DIAGRAM, 13351111
3	1	AACPU1215C	PLC,S7-1200,CPU,T,14DI,10DQ
4	1	AAE1335-12	SOLENOID ASSY,12 STATION
5	1	AASM1222BH1	MOUDLE, PLC,S7-1200, 16DI
6	1	AASM1223BH	MOUDLE, PLC,S7-1200, 16DI
7	1	AASM1223PL	MOUDLE, PLC,S7-1200, 16DI
8	*10	EE15691800	WIRE, STR, #18, PVC, BLK UL1569
9	*10	EE15691802	WIRE, STR, #18, PVC, RED UL1569
10	*5	EE15691805	WIRE, STR, #18, PVC, GRN UL1569
11	4	EECLIPFIX	ANCHOR,DIN RAIL
12	*28"	EEDC1LG	DUCT,WIRE COVER,1"
13	*60"	EEDC2X2	COVER,WIRE DUCT
14	*28"	EEDF1X2	DUCT,WIRE,1X2
15	*60"	EEDF2X2	DUCT,WIRE,2X2, MOD
16	*29"	EETS35X7.5A	DIN RAIL-AMERICAN
17	*10	FF118125C	CABLE,25 COND,22AWG,500'
18	*5	FF118160C	CABLE,60 COND,22AWG,500'
19	2	FF280-319	TERMBLK,WAGO,SENSOR,DIN
20	96	FF280-402	JUMPER,WAGO,TOP,SNGL
21	50	FF280-560	TERMBLK,WAGO,SENSOR,DIN
22	*6	FF36F198WA	22 GA, 15 COND, WIRE
23	*33	SSPP90024	8-32X3/8 PAN PHLPS
24	*33	WWF8	WASHER, FLAT, #8

13351012 ROTATE ASSEMBLY

AAC Drawing Number 13351012 Rev 0

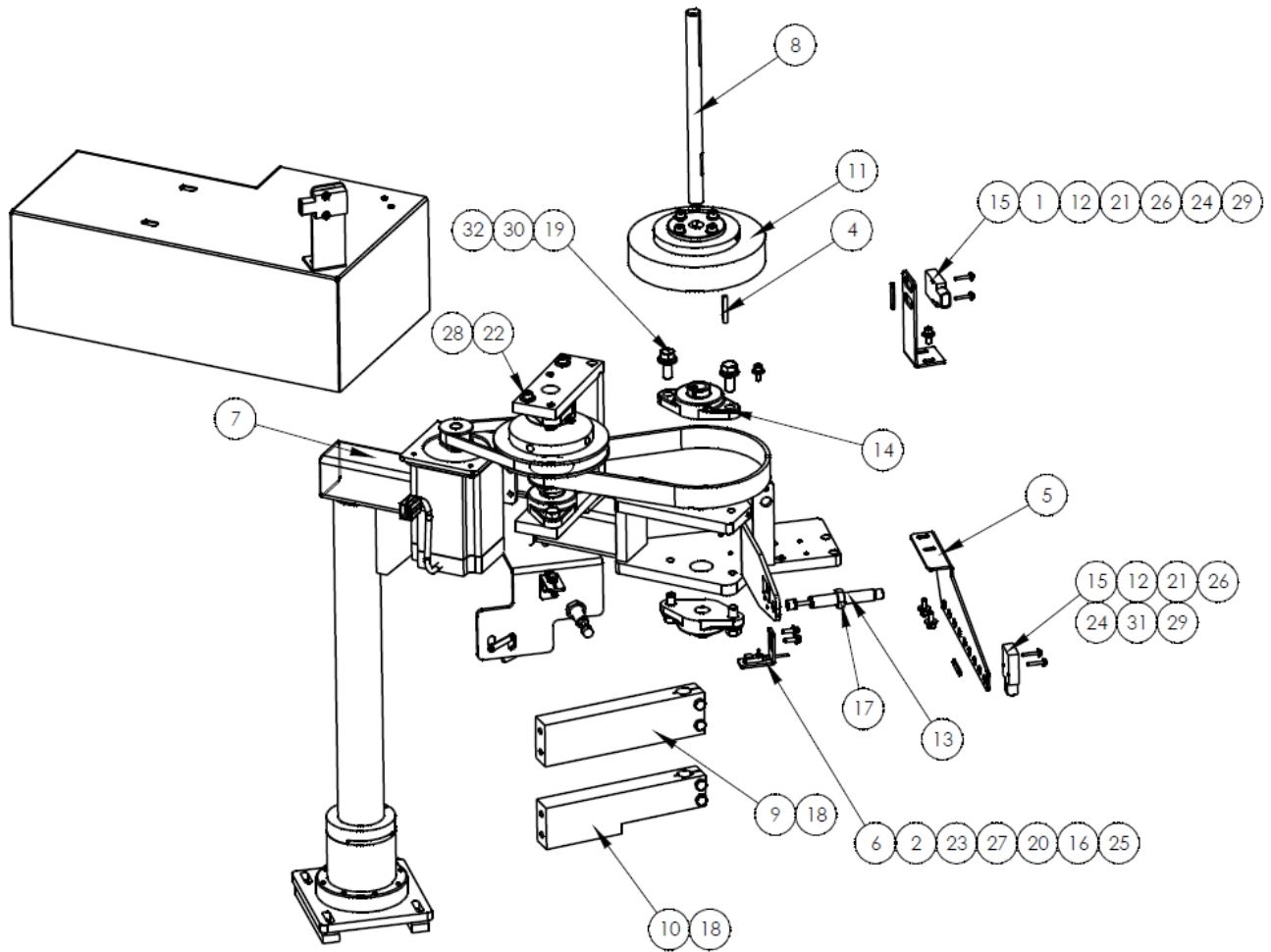

13351012 parts list

ITEM NO.	QTY.	PART NUMBER	DESCRIPTION
1	2	1278-6689B	BRACKET, EYE MOUNT
2	1	1278-7055D	PROX SWITCH W/PLUG,12"
3	1	1325007	COVER, PULLEY AND MOTOR
4	1	132556-248	KEY, 3/16 X 1.25L
5	1	132556-263B	BRACKET, SENSOR, LONG
6	1	132556-268A	BRKT, PROX SWITCH
7	1	13351013	ROTATE ARM ASSY,1335BS88
8	1	13351016	SHAFT, DRIVE, TURN ARM, 9.25L
9	1	13351041	UPPER SWING ARM CLAMP
10	1	13351042	LOWER SWING ARM CLAMP
11	1	1335277	PULLEY,GEAR,48 TH
12	3	1975-412A	PLATE,NUT,4-40,.95CTC
13	1	AAPR025IF2B	SHOCK 5/8 STK,1/2-20 THD
14	2	BBVF2S-110	BRG,FLG BLK,5/8 B,2 BLT
15	3	FFSM312LVQ	EYE,ELECTRIC,10-30VDC
16	1	NNH2-56	NUT,HEX,2-56
17	1	NNJ1/2-20	NUT, JAM, 1/2-20
18	4	SSHC01064	1/4-20 X 1 HHCS
19	4	SSHC25064	3/8-16 X 1,HEX CAP
20	1	SSPS50032	SCREW,2-56 x 1/2
21	6	SSPS70048	4-40 X 3/4 PAN HD SLOTTED
22	4	SSSC01024	1/4-20 X 3/8 SOC CAP SC
23	2	SSSC90032	#8-32 X 1/2 SOC CAP SC
24	4	SSSC98032	10-32X1/2, SOC CAP
25	1	WWF2	WASHER, FLAT, #2
26	6	WWF4	WASHER, FLAT, #4
27	2	WWF8	WASHER, FLAT, #8
28	4	WWFS1/4	WASHER,FLAT,SAE,1/4
29	4	WWFS10	WASHER, FLAT, #10, SAE
30	4	WWFS3/8	WASHER,FLAT,SAE,3/8
31	4	WWL10	WASHER,LOCK,#10
32	4	WWL3/8	WASHER,LOCK, 3/8

13351013 ROTATE ARM ASSY,1335BS88

AAC Drawing Number 13351013 Rev 1

192433C

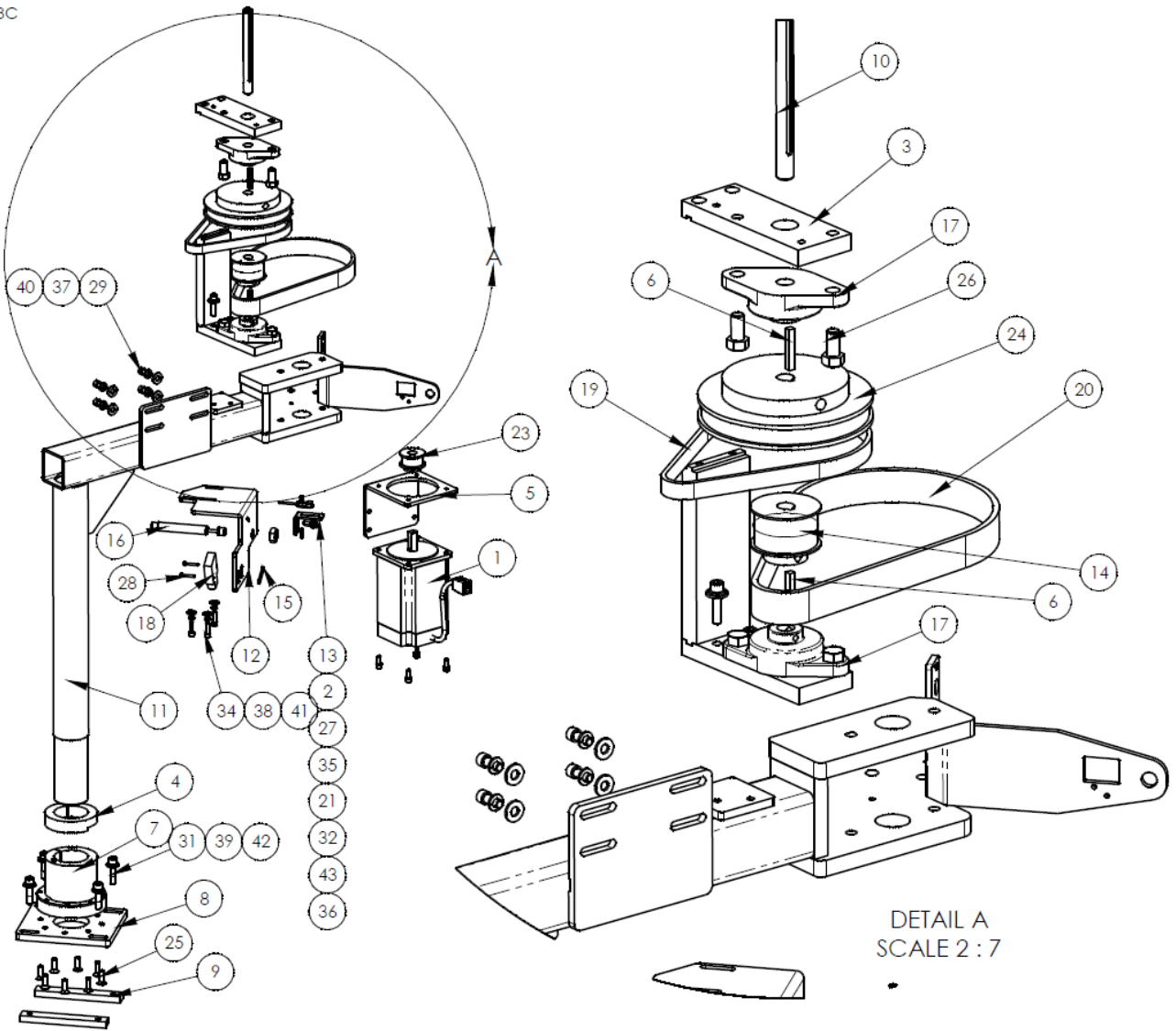

13351013 parts list

ITEM NO.	QTY.	PART NUMBER	DESCRIPTION
1	1	011-020C	STEPPER MOTOR, W/PLUG
2	1	1278-7055D	PROX SWITCH W/PLUG,12"
3	1	1318510	IDLER SHAFT BRACKET
4	1	132556-230A	CLAMP COLLAR- 31/16 I.D.
5	1	132556-240	BRKT, MOTOR MOUNTING
6	2	132556-248	KEY, 3/16 X 1.25L
7	1	132556-260	SUPPORT COLUMN
8	1	132556-261	BRKT, COLLAR MOUNT, UPPER
9	2	132556-262	BRKT, SUPPORT MOUNT, LOWER
10	1	132556-264	SHAFT 1/2 X 5.12L
11	1	13351014	ARM SUPPORT ASSY, TALL
12	1	13351019	BRKT, SHOCK
13	1	13351021	BRKT, PROX SWITCH MTG
14	1	1335254	PULLEY,GEAR,AT10P,15T
15	1	1975-412A	PLATE,NUT,4-40,.95CTC
16	1	AAPR025IF2B	SHOCK 5/8 STK,1/2-20 THD
17	2	BBMF2S-208	BEARING,FLANGE BLOCK
18	1	FFSM312LVQ	EYE,ELECTRIC,10-30VDC
19	1	GG187L050	BELT, 3/8P, 50T, 1/2W
20	1	GG25AT10/660BFX	BELT,AT10P,25MM,660MM LG
21	1	NNH2-56	NUT,HEX,2-56
22	1	NNJ1/2-20	NUT, JAM, 1/2-20
23	1	PP10LF050M	PULLEY,GEAR,3/8 PITCH
24	1	PP40LB050M1	PULLEY,3/8PX1/2WX40T
25	8	SSFC01048	1/4-20 X 3/4 FLAT CAP
26	4	SSHC25048	3/8-16X3/4,HEX CAP
27	1	SSPS50032	SCREW,2-56 x 1/2
28	2	SSPS70048	4-40 X 3/4 PAN HD SLOTTED
29	4	SSSC05040	1/4-28 X 5/8, SOC CAP
30	2	SSSC05064	1/4-28 X 1 SOC CAP
31	4	SSSC10080	5/16-18 X 1-1/4 SOC CAP
32	2	SSSC90032	#8-32 X 1/2 SOC CAP SC
33	4	SSSC98032	10-32X1/2, SOC CAP
34	3	SSSC98040	10-32 X 5/8 SOC CAP
35	1	WWF2	WASHER, FLAT, #2
36	2	WWF8	WASHER, FLAT, #8
37	6	WWFS1/4	WASHER,FLAT,SAE,1/4
38	3	WWFS10	WASHER, FLAT, #10, SAE
39	4	WWFS5/16	WASHER,FLAT,SAE,5/16
40	6	WWL1/4	WASHER,LOCK, 1/4
41	7	WWL10	WASHER,LOCK,#10
42	4	WWL5/16	WASHER,LOCK, 5/16
43	2	WWL8	WASHER,LOCK,#8

1334BP-WD WIRING DIAGRAM I/O CONTROL

AAC Drawing Number 125817D REV 1

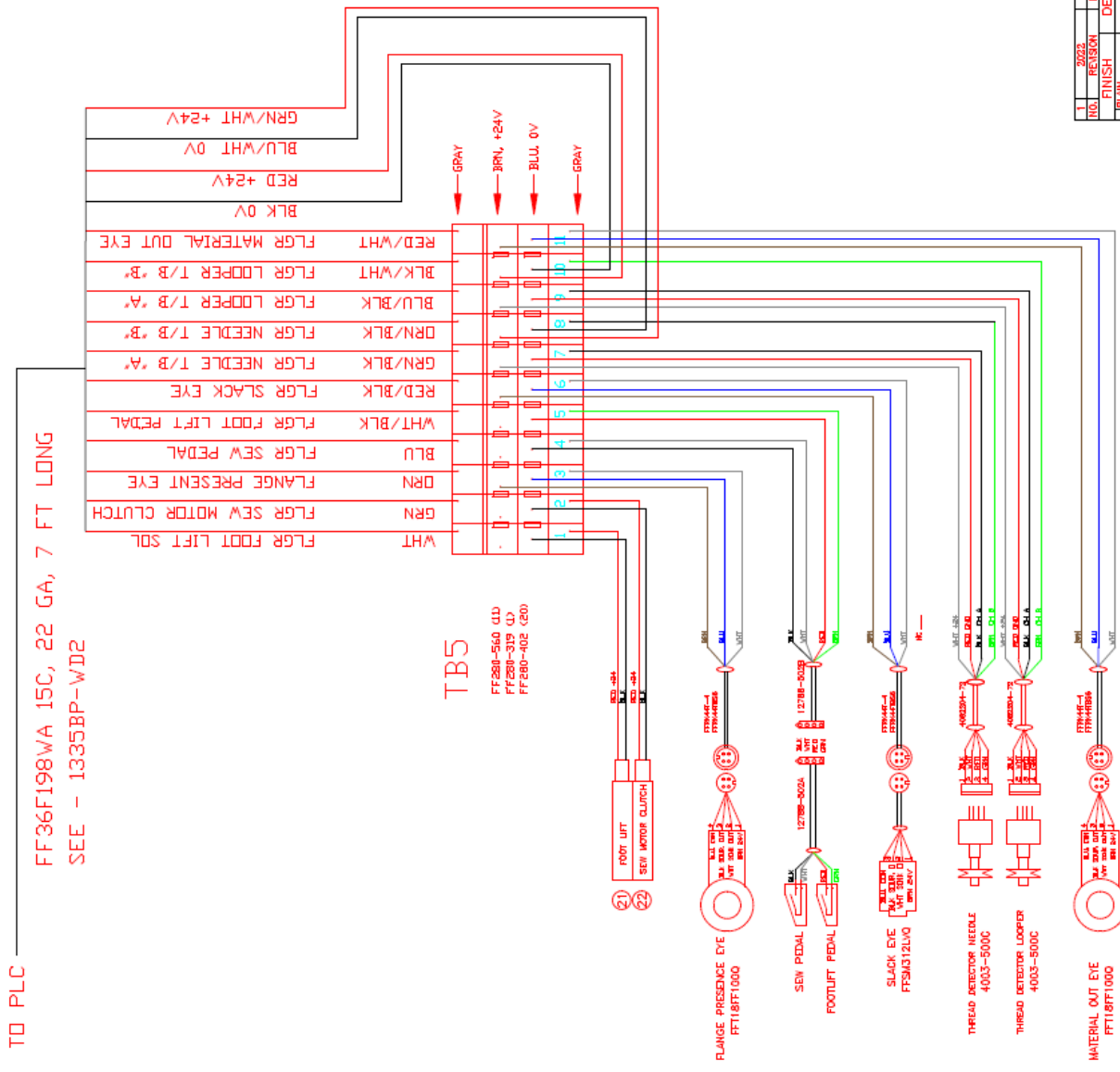

QTY	ITEM	DESCRIPTION	SCALE	NO.
1	2025	1/7	RE	REV
100	FINISH	DATE	DR.	OK
DEFULTS				
ATLANTA ATTACHMENT COMPANY NAME DIAGRAM WIRING I/O CONTROL DR. DES. AUTO FLANGER, PLC MATERIAL ASSEMBLY 1334BY28P PART NO. 1334BP-WD DR. BY PBD DRAWING NO. 125817D CK. BY JEFF THOMAS DATE: 4/29/19 SCALE 1/4"				



2019

1334BP-WD1 WIRING DIAGRAM PLC I/O L

AAC Drawing Number 125822D Rev 1

CABLE #1 PLC TO MAIN PANEL

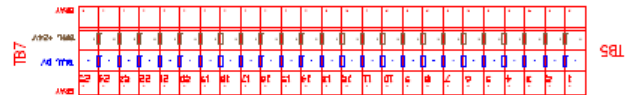
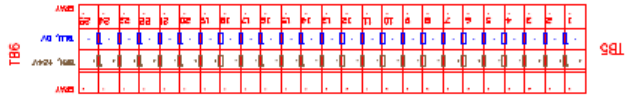
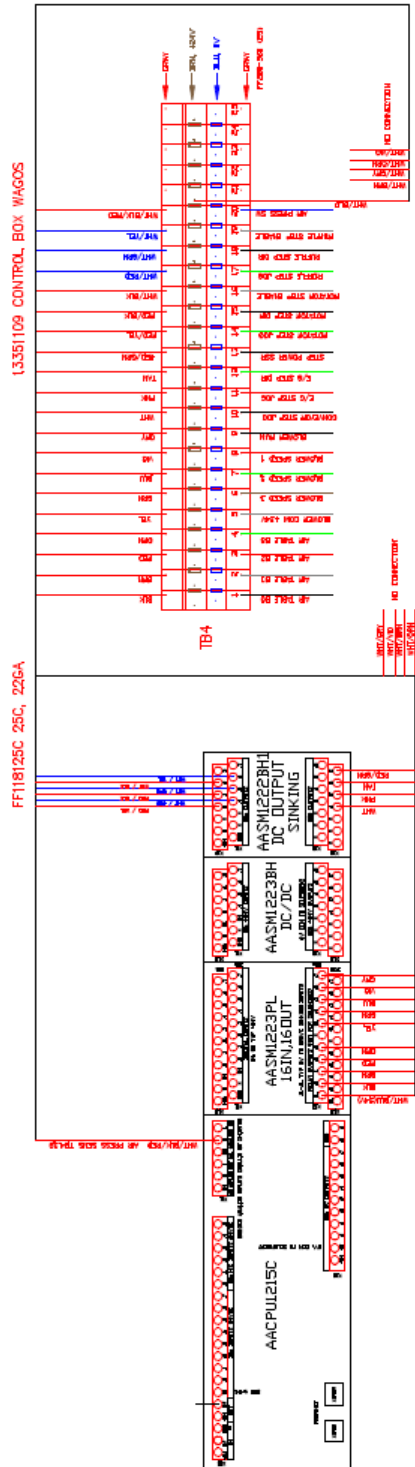

CABLE #1 WIRING
SHEET #2
125822D

13351111 CONTROL BOX WAGOS

PLC POWER WIRING

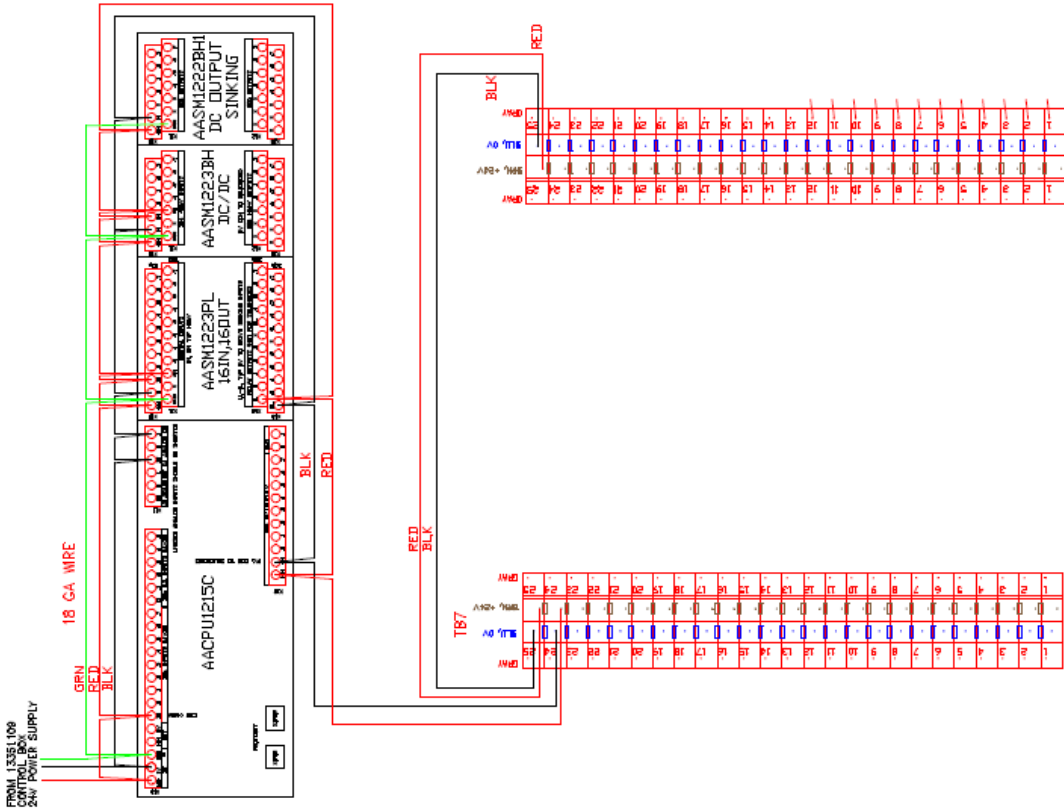
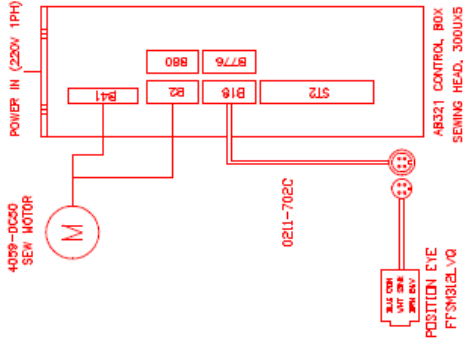

TB6, TB7
SHEET#3
125822D

13351111 CONTROL BOX WAGOS

Atlanta Attachment Company (AAC) Statement of Warranty

Manufactured Products

Atlanta Attachment Company warrants manufactured products to be free from defects in material and workmanship for a period of eight hundred (800) hours of operation or one hundred (100) days whichever comes first. Atlanta Attachment Company warrants all electrical components of the Serial Bus System to be free from defects in material or workmanship for a period of thirty-six (36) months.

Terms and Conditions:

- AAC Limited Warranty becomes effective on the date of shipment.
- AAC Warranty claims may be made by telephone, letter, fax, or e-mail. All verbal claims must be confirmed in writing.
- AAC reserves the right to require the return of all claimed defective parts with a completed warranty claim form.
- AAC will, at its option, repair or replace the defective machine and parts upon return to AAC.
- AAC reserves the right to make the final decision on all warranty coverage questions.
- AAC warranty periods as stated are for eight hundred (800) hours or one hundred (100) days whichever comes first.
- AAC guarantees satisfactory operation of the machines on the basis of generally accepted industry standards, contingent upon proper application, installation, and maintenance.
- AAC Limited Warranty may not be changed or modified and is not subject to any other warranty expressed or implied by any other agent, dealer, or distributor unless approved in writing by AAC in advance of any claim being filed.

What Is Covered

- Electrical components that are not included within the Serial Bus System that fail due to defects in material or workmanship, which are manufactured by AAC are covered for a period of eight hundred (800) hours.
- Mechanical parts or components that fail due to defects in material or workmanship, which are manufactured by AAC.
- Purchased items (sewing heads, motors, etc.) will be covered by the manufacturers (OEM) warranty.
- AAC will assist in the procurement and handling of the manufacturers (OEM) claim.

What Is Not Covered

- Parts that fail due to improper usage, lack of proper maintenance, lubrication and/or modification.
- Damages caused by; improper freight handling, accidents, fire, and issues resulting from unauthorized service and/or personnel, improper electrical, plumbing connections.
- Normal wear of machine and parts such as Conveyor belts, "O" rings, gauge parts, cutters, needles, etc.
- Machine adjustments related to sewing applications and/or general machine operation.
- Charges for field service.
- Loss of time, potential revenue, and/or profits.
- Personal injury and/or property damage resulting from the operation of this equipment.

Declaración de Garantía

Productos Manufacturados

Atlanta Attachment Company garantiza que los productos de fabricación son libres de defectos de material y de mano de obra durante un periodo de ochocientos (800) horas de operación o cien (100) días cual llegue primero. Atlanta Attachment Company garantiza que todos los componentes del Serial bus son libres de defectos de material y de mano de obra durante un periodo de treinta y seis (36) meses.

Términos y Condiciones:

- La Garantía Limitada de AAC entra en efecto el día de transporte.
- Reclamos de la Garantía de AAC pueden ser realizados por teléfono, carta, fax o correo electrónico. Todo reclamo verbal tiene que ser confirmado vía escrito.
- AAC reserva el derecho para exigir el retorno de cada pieza defectuosa con un formulario de reclamo de garantía.
- AAC va, según su criterio, reparar o reemplazar las máquinas o piezas defectuosas devueltas para AAC.
- AAC reserva el derecho para tomar la decisión final sobre toda cuestión de garantía.
- Las garantías de AAC tiene una validez de ochocientas (800) horas o cien (100) días cual llega primero.
- AAC garantiza la operación satisfactoria de sus máquinas en base de las normas aceptadas de la industria siempre y cuando se instale use y mantenga de forma apropiada.
- La garantía de AAC no puede ser cambiado o modificado y no está sujeto a cualquier otra garantía implicado por otro agente o distribuidor menos al menos que sea autorizado por AAC antes de cualquier reclamo.

Lo Que Está Garantizado

- Componentes eléctricos que no están incluidos dentro del sistema Serial Bus que fallen por defectos de materiales o de fabricación que han sido manufacturados por AAC son garantizados por un periodo de ochocientas (800) horas.
- Componentes mecánicos que fallen por defectos de materiales o de fabricación que han sido manufacturados por AAC son garantizados por un periodo de ochocientas (800) horas.
- Componentes comprados (Motores, Cabezales,) son protegidos debajo de la garantía del fabricante.
- AAC asistirá con el manejo de todo reclamo de garantía bajo la garantía del fabricante.

Lo Que No Está Garantizado

- Falla de repuestos al raíz de uso incorrecto, falta de mantenimiento, lubricación o modificación.
- Daños ocurridos a raíz de mal transporte, accidentes, incendios o cualquier daño como resultado de servicio por personas no autorizados o instalaciones incorrectas de conexiones eléctricas o neumáticas.
- Desgaste normal de piezas como correas, anillos de goma, cuchillas, agujas, etc.
- Ajustes de la máquina en relación con las aplicaciones de costura y/o la operación en general de la máquina.
- Gastos de Reparaciones fuera de las instalaciones de AAC
- Pérdida de tiempo, ingresos potenciales, y/o ganancias.
- Daños personales y/o daños a la propiedad como resultado de la operación de este equipo.



Atlanta Attachment Company
362 Industrial Park Drive
Lawrenceville, GA 30046
770-963-7369
www.atlatt.com

Printed in the USA
