



# 1309

Model  
Spring Unbaler

Revision 9 Updated January 16, 2023

## Technical Manual & Parts Lists

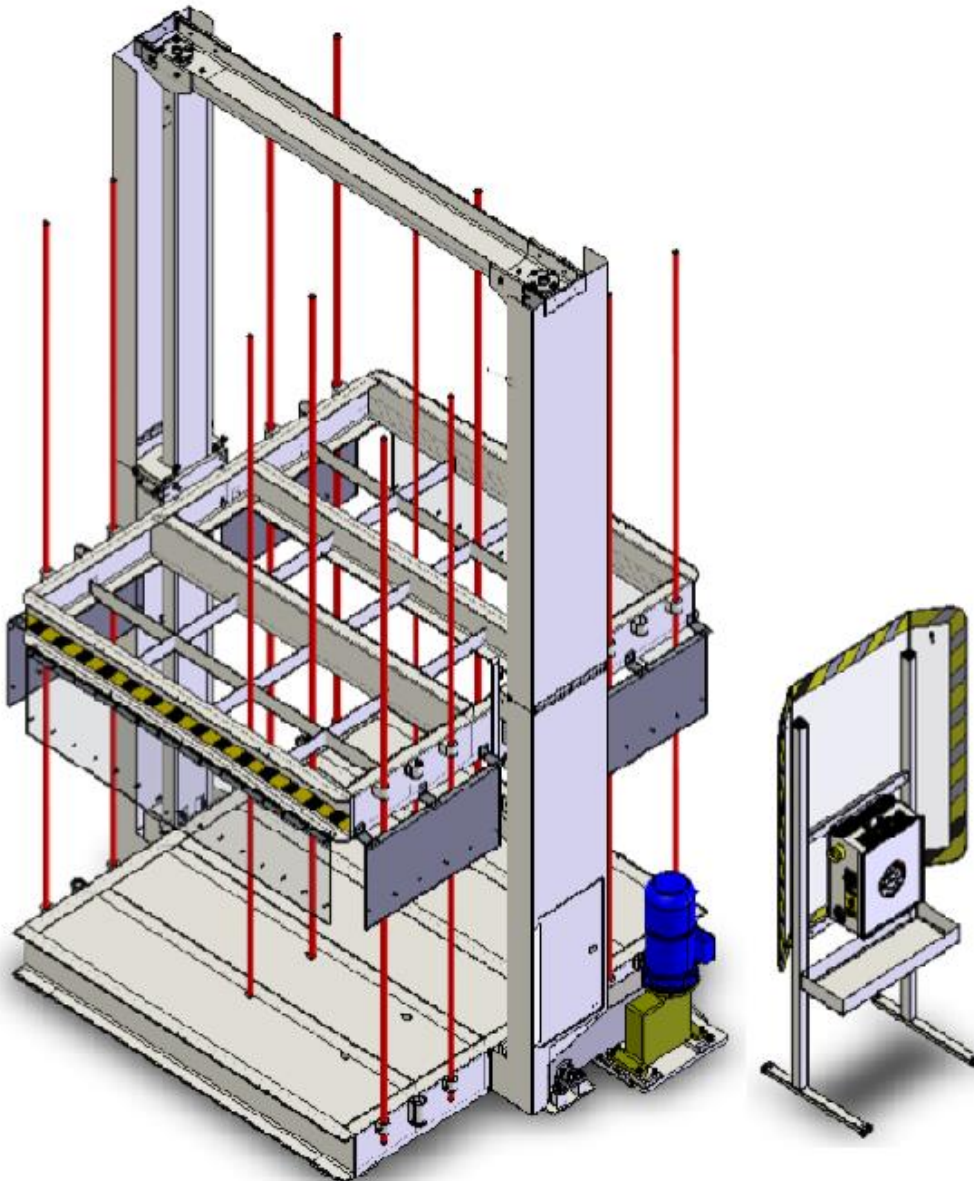

**Atlanta Attachment Company**

362 Industrial Park Drive

Lawrenceville, GA 30046

770-963-7369 • [www.atlatt.com](http://www.atlatt.com)



# ATLANTA ATTACHMENT COMPANY, INC.

## Confidential and Proprietary Information

The materials contained herein are confidential and proprietary information of Atlanta Attachment Company. In addition to any confidentiality and non-disclosure obligations that currently exist between you and Atlanta Attachment Company, your use of these materials serves as an acknowledgment of the confidential and proprietary nature of these materials and your duty not to make any unauthorized use or disclosure of these materials.

All materials contained herein are additionally protected by United States Copyright law and may not be used, disclosed, reproduced, distributed, published, or sold without the express written consent of Atlanta Attachment Company, which consent may be withheld in Atlanta Attachment Company's sole discretion. You may not alter or remove any copyright, trademark, or other notice from copies of these materials.

<b>IMPORTANT</b>
<b>It is important to read and understand the information contained within this manual before attempting to operate the machine. Atlanta Attachment Co., Inc. shall not be held liable for damage resulting from misuse of the information presented within, and reserves the right to change the information contained within, without prior notification.</b>

# Contents

Important Safety Instruction .....	0
Mandatory Information .....	0
Scope of the Instruction Material .....	0
Intended Use .....	0
Exclusion of Misuse .....	0
Liability .....	1
Choice and Qualification of Personnel .....	1
Training .....	1
Responsibilities .....	1
A Word to the Operator .....	2
Safety Equipment on the Machines .....	2
Damage .....	2
Faults or Errors .....	2
Signs on the Machine .....	2
Protective Eyewear .....	3
Tools .....	3
Oils, Lubricants, Chemicals .....	3
No Smoking, Fire, Explosion Hazard .....	3
Workplace .....	3
Emergency STOP .....	3
First Aid .....	3
Important Notices .....	4
Reporting and Fighting Fires .....	4
Electrical Power Supply .....	4
Delivery of the Machine/Packaging .....	5
Transport Damage .....	5
Interim Storage .....	5
Transporting the Machine .....	5
Workplace Environment .....	6
Local Regulations .....	6
Maintenance .....	6
General Safety Instructions .....	6
Maintenance, Care, Adjustment .....	6
Waste, Disassembly, Disposal .....	6
Repair .....	7
Replacement Parts .....	7

## Technical Manual & Parts Lists

---

Repair, Electrical.....	7
Ventilation/Hazardous Gases.....	7
Hydraulic and Pneumatic Systems.....	7
General Liability.....	8
Starting Machine Movements.....	8
A Word to the End User.....	8
Safety Precautions.....	9
General Machine Data.....	10
Specifications.....	10
Tools Required for Installation.....	10
1309 Foot Print.....	11
Installation Instructions.....	12
Leveling the Upper Platform Side to Side.....	27
Important.....	27
Leveling the Upper Platform Front to Back.....	30
Solving Binding Issues.....	31
Operating Instructions.....	33
Machine Maintenance.....	34
Daily (8 -10 hrs. of operation).....	34
Weekly (40 hrs. of operation).....	34
Monthly (160 hrs. of operation).....	34
Assembly Drawings & Parts Lists.....	35
11309 Main Assembly.....	36
1309015 Operator Station Assembly.....	42
1309018 Control Panel Assembly.....	43
1309-WD Wiring Schematic, Unbaler, NON-UL Certified.....	45
1309-WD1 Wiring Diagram, 220 Volt Input, Panel Wiring.....	46
1309-WD4 Wiring Schematic, Unbaler.....	47
1309-WD2 Wiring Schematic, Unbaler, UL Certified, 220 Volt Input.....	48
1309-WD3 Wiring Schematic, Unbaler, UL Certified, Panel Wiring.....	49

---

# Important Safety Instruction



This part of the Instruction Material is provided for the safe use of your equipment. It contains important information to help work safely with the unit and describes the dangers inherent in machinery. Some of these dangers are obvious, while others are less evident.

## Mandatory Information

All persons operating and/or working on the 1309 Spring Unbaler should read and understand all parts of the Safety Instructions. This applies, in particular, for persons who only operate and/or work on the unit occasionally (e.g. for maintenance and repair). Persons who have difficulty reading must receive particularly thorough instruction.

## Scope of the Instruction Material

- The Instruction Material comprises:
- Safety information
- Operator Instructions
- Electrical and Pneumatic diagrams

And may also include.

- A list of recommended spare parts
- Instruction Manual(s) for components made by other manufacturers
- The layout and installation diagram containing information for installation

## Intended Use

Our machines are designed and built-in line with the state of the art and the accepted safety rules. However, all machines may endanger the life and limb of their users and/or third parties and be damaged or cause damage to other property, particularly if they are operated incorrectly or used for purposes other than those specified in the Instruction Manual.

## Exclusion of Misuse



Non-conforming uses include, for example, using the equipment for something other than it was designed for, as well as operation without duly installed safety equipment. The risk rests exclusively with the end user.

Conforming use of the machine includes compliance with the technical data, information, and regulations in all parts of the complete Instruction Material, as well as compliance with the maintenance regulations. All local safety and accident prevention regulations must also be observed.

## **Liability**

The machine should only be operated when in perfect working order, with due regard for safety and the potential dangers, as well as in accordance with the Instruction Material. Faults and malfunctions capable of impairing safety should be remedied immediately. We cannot accept any liability for personal injury or property damage due to operator errors or non-compliance with the safety instructions contained in this booklet. The risk rests exclusively with the end user.

The Instruction Material should always be kept near the machine so that it is accessible to all concerned.

The local, general, statutory, and other binding regulations on accident prevention and environmental protection must also be observed in addition to the Instruction Material. The operating staff must be instructed accordingly. This obligation also includes the handling of dangerous substances and provision/use of personal protective equipment.

The Instruction Material should be supplemented by instructions, including supervisory and notification duties with due regard for special operational features, such as the organization of work, work sequences, the personnel deployed, etc.

The personnel's awareness of the dangers and compliance with the safety regulations should be checked at irregular intervals.

## **Choice and Qualification of Personnel**

Ensure that work on the machine is only carried out by reliable persons who have been appropriately trained for such work - either within the company, by our field staff or at our office - and who have not only been duly appointed and authorized but are also fully familiar with the local regulations. Work on the machine should only be carried out by skilled personnel, under the management and supervision of a duly qualified engineer.

This not only applies when the machine is used for production, but also for special work associated with its operation (start-up and maintenance), especially when it concerns work on the hydraulic or electrical systems, as well as on the software/serial bus system.

## **Training**

Everyone working on or with the machine should be duly trained and informed about the correct use of the safety equipment, the foreseeable dangers which may arise during operation of the machine and the safety precautions to be taken. In addition, the personnel should be instructed to check all safety mechanisms at regular intervals.

## **Responsibilities**

Clearly define exactly who is responsible for operating, setting-up, servicing and repairing the machine. Define the responsibilities of the machine operator and authorize him to refuse any instructions by third parties if they run contrary to the machine's safety. This applies for the operators of machines linked to other equipment. Persons receiving training of any kind may only work on or with the machine under the constant supervision of an experienced operator. Note the minimum age limits permitted by law.

## A Word to the Operator

The greatest danger inherent in our machines: is that of fingers, hands or loose clothing being drawn into a machine by live, coasting or rotating tools or assemblies or of being cut by sharp tools or burned by hot elements.

### **ALWAYS BE CONSCIOUS OF THESE DANGERS!**

## Safety Equipment on the Machines



All machines are delivered with safety equipment, which shall not be removed or bypassed during operation.

The correct functioning of safety equipment on machines and systems should be checked every day and before every new shift starts, after maintenance and repair work, when starting up for the first time and when restarting (e.g. after prolonged shutdowns).

If safety equipment must be dismantled for setting-up, maintenance or repair work, such safety equipment shall be replaced and checked immediately upon completing the maintenance or repair work.

All protective mechanisms shall be fitted and fully operational whenever the machine is at a standstill or if it has been shut down for a longer period.

## Damage

If any changes capable of impairing safety are observed in the machine or its mode of operation, such as malfunctions, faults or changes in the machine or tools, appropriate steps must be taken immediately, the machine switched off and a proper lockout tagout procedure followed. The machine should be examined for obvious damage and defects at least once per shift. Damage found shall be immediately remedied by a duly authorized person before resuming operation of machine.

The machine should only be operated when in perfect working order and when all protective mechanisms and safety equipment, such as detachable protective mechanisms, emergency STOP systems, etc. are in place and operational.

## Faults or Errors

The machine must be switched off and all moving or rotating parts allowed to come to a standstill and secured against accidental restart before starting to remedy any faults or errors.

## Signs on the Machine

Safety and danger signs on the machine should be observed and checked at regular intervals to ensure that they are complete and undamaged. They should always be clearly posted, visible and legible with listings of Clothing, Jewelry and Protective Equipment. Long loose hair, loose-fitting clothes, gloves and jewelry, including rings, should be avoided in order to avoid injuries due to being caught, drawn in and wound up inside the machine.

## Protective Eyewear

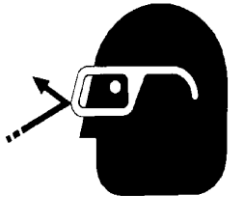

Protective eyewear that has been tested by the local authorities should be worn whenever there is a possibility of loose or flying objects or particles such as when cleaning the machine with compressed air.

### Tools

Always count the number of tools in your possession before starting work on the machine. This will allow you to check that no tools have been left behind inside the machine. Never leave a tool in the machine while working.

### Oils, Lubricants, Chemicals

Note the applicable safety regulations for the product used.

### No Smoking, Fire, Explosion Hazard

Smoking and open flame (e.g. welding work) should be prohibited in the production area due to the risk of fire and explosions.

### Workplace

A clear working area without any obstructions whatsoever is essential for safe operation of the machine. The floor should be level and clean, without any waste.

The workplace should be well lit, either by the general lighting or by local lights.

### Emergency STOP

The emergency STOP buttons bring all machine movements to a standstill. Make sure you know exactly where they are located and how they work. Try them out. Always ensure easy access to the nearest emergency STOP button while working on the machine.

### First Aid

1. Keep calm even when injured.
2. Clear the operator from the danger zone. The decision of what to do and whether to seek additional assistance rests entirely with you, particularly if someone has been trapped.
3. Give First Aid. Special courses are offered by such organizations as the employers' liability insurance association. Your colleagues should be able to rely on you and vice versa.
4. Call an ambulance. Do you know the telephone numbers for the ambulance service, police, and fire service?

## Important Notices

### Reporting and Fighting Fires

Read the instructions posted in the factory about reporting fires and the emergency exits. Make sure you know exactly where the fire extinguishers and sprinkler systems are located and how they are operated. Pass on the corresponding information to the firemen when they arrive. Ensure there are enough signs to avoid fire hazards.

The following fire extinguishers may be used:

- Dry powder extinguishers, ABC fire-extinguishing powder.
- Carbon dioxide fire extinguishers to DIN 14461 for electronic components. Great care must be exercised when using carbon dioxide fire extinguishers in confined, badly ventilated rooms (see DIN 14406 and 14270).

Isolate the machine from the power supply if a fire breaks out. Do not use water on burning electrical parts until it is certain that they have been completely disconnected from the power supply. Burning oils, lubricants, plastics, and coatings on the machine can give off gases and vapors that may be harmful to your health.

A qualified person should be consulted to repair the damage after a fire.

### Electrical Power Supply



Before undertaking any maintenance or repair work on the machine, switch off the electrical power to the machine at the main source and secure it with a padlock so that it cannot be switched on again without authorization.

In practice, this may mean that the technician, electrician, and operator all attach their own padlock to the master switch simultaneously so that they can carry out their work safely. Locking extension plates should be available for multiple locks if required. The primary purpose for a lockout/tagout procedure is to protect workers from injury caused by unexpected energizing or start-up of equipment.

Energy sources (electrical/pneumatic/hydraulic, etc.) for the equipment shall be turned off or disconnected and the switches locked or labeled with a warning tag. It is the responsibility of the employer to establish control procedures. Follow lockout/tagout procedures before, setup and/or any service or maintenance work is performed, including lubrication, cleaning, or clearance of jams.

**Caution: The machine is still not completely de-energized even when the master switch is off.**

- Electricity - The machine is always isolated from the electrical power supply whenever the master switch has been switched off. However, this does not apply for the power supply in the control cabinet, nor for equipment that does not draw its power via the master switch.
- Pneumatic / hydraulic energy - Almost all our machines carry compressed air. In addition to switching off the master switch, the air supply must also be disconnected, and the machine checked to ensure it is depressurized before starting any work on the machine; otherwise, the machine may execute uncontrolled movements.

- Kinetic energy - Note that some motors or spindles, for example, may continue to run or coast run on after being switched off.
- Potential energy - Individual assemblies may need to be secured if necessary for repair work.

## **Delivery of the Machine/Packaging**

Note any markings on the packaging, such as weights, lifting points and special information. Avoid temperature fluctuations. Condensation may damage the machine.

## **Transport Damage**

The packaging and machine must immediately be examined for signs of damage in transit. Such damage must be reported to the shipper/transporter within the applicable time limits. Contact Atlanta Attachment Company and/or your transport insurer immediately, if signs of damage are visible. Never operate a damaged machine.

## **Interim Storage**

If the machine must be stored temporarily, it must be oiled or greased and stored in a dry place where it is protected from the weather to avoid damage. A corrosion-inhibiting coating should be applied if the machine must be stored for a longer period and additional precautions taken to avoid corrosion.

## **Transporting the Machine**

Disconnect the machine from all external connections and secure any loose assemblies or parts. Never step under a suspended load. When transporting the machine or assemblies in a crate, ensure that the ropes or arms of a forklift truck are positioned as close to the edge of the crate as possible. The center of gravity is not necessarily in the middle of the crate. Note the accident prevention regulations, safety instructions and local regulations governing transport of the machine and its assemblies.

Only use suitable transport vehicles, hoisting gear and load suspension devices that are in perfect working order and of adequate carrying capacity. Transport should only be entrusted to duly qualified personnel.

Never allow the straps to rest against the machine enclosure and never push or pull sensitive parts of the machine. Ensure that the load is always properly secured. Before or immediately after loading the machine, secure it properly and affix corresponding warnings.

All transport guards and lifting devices must be removed before the machine is started up again. Any parts that are to be removed for transport must be carefully refitted and secured before the machine is started up again.

## Workplace Environment

Our machines are designed for use in enclosed rooms: Permissible ambient temperature approx. 5 - 40 °C (40 - 104 °F). Malfunctions of the control systems and uncontrolled machine movements may occur at temperatures outside this range.

Protect against climatic influences, such as electrostatic charges, lightning strikes, hail, storm damage, high humidity, salinity of the air in coastal regions.

Protect against influences from the surroundings: no structure-borne vibrations, no grinding dust, or chemical vapors.

Protect against unauthorized access.

Ensure that the machine and accessories are set up in a stable position.

Ensure easy access for operation and maintenance (Instruction Manual and layout diagram); also verify that the floor is strong enough to carry the weight of the machine.

## Local Regulations

Particular attention must be paid to local and statutory regulations, etc. when installing machines and the plant (e.g. with regard to the specified escape routes). Note the safety zones in relation to adjacent machines.

## Maintenance

### General Safety Instructions

The machine shall be switched off, come to a standstill, and be secured so that it cannot be switched on again inadvertently before starting any maintenance work whatsoever. Use proper lockout/tagout procedures to secure the machine against inadvertent startup.

Remove any oil, grease, dirt, and waste from the machine, particularly from the connections and screws, when starting the maintenance and/or repair work. Do not use any corrosive-cleaning agents. Use lint-free rags.

Retighten all screw connections that must be loosened for the maintenance and repair work. Any safety mechanisms that must be dismantled for setting-up, maintenance or repair purposes must be refitted and checked immediately after completing the work.

### Maintenance, Care, Adjustment

The activities and intervals specified in the Instruction Manual for carrying out adjustments, maintenance and inspections must be observed, and parts replaced as specified.

All hydraulic and pneumatic lines should be examined for leaks, loose connections, rubbing and damage whenever the machine is serviced. Any defects found must be remedied immediately.

### Waste, Disassembly, Disposal

Waste products should be cleared from the machine as soon as possible as not to create a fire hazard.

Ensure that fuels and operating lubricants, as well as replacement parts are disposed of in a safe and ecologically acceptable manner. Note the local regulations on pollution control.

When scrapping (disassembling) the machine and its assemblies, ensure that these materials are disposed of safely. Either commission a specialist company familiar with the local regulations or note the local regulations when disposing of these materials yourself. Materials should be sorted properly.

## Repair

### Replacement Parts

We cannot accept any liability whatsoever for damage due to the use of parts made by other manufacturers or due to unqualified repair or modification of the machine.

### Repair, Electrical

The power supply must be switched off (master switch off) and secured so that it cannot be switched on again inadvertently before starting any work on live parts.

Those parts of the machine and plant on which inspection, maintenance or repair work is to be carried out must be isolated from the power supply, if specified. The isolated parts must first be checked to determine that they are truly de-energized before being grounded and short-circuited. Adjacent live parts must also be isolated.

The protective measures implemented (e.g. grounding resistance) must be tested before restarting the machine after all assembly or repair work on electric parts.

Signal generators (limit switches) and other electrical parts on the safety mechanisms must not be removed or bypassed. Only use original fuses or circuit overloads with the specified current rating. The machine must be switched off immediately if a fault develops in the electrical power supply.

The electrical equipment of our machines must be checked at regular intervals and any defects found must be remedied immediately.

If it is necessary to carry out work on live parts, a second person should be on hand to operate the emergency OFF switch or master switch with voltage release in the event of an emergency. The working area should be cordoned off and marked by a warning sign. Only use electrically insulated tools.

### Ventilation/Hazardous Gases

It is the end user's responsibility to ensure adequate ventilation is provided to exhaust all noxious or hazardous gases that may be present in the working environment.

### Hydraulic and Pneumatic Systems

Work on hydraulic or pneumatic equipment shall only be carried out by persons with training, knowledge, and experience of hydraulic systems. Pressure lines shall be depressurized before starting any repair work.

## **General Liability**

Liability for machine damage and personal injury is extinguished completely if any unauthorized conversions or modifications are undertaken. The machine must not be modified, enlarged, or converted in any way capable of affecting safety without the manufacturer's prior approval.

## **Starting Machine Movements**

Read the Instruction Manual carefully to establish which keys and functions start machine movements.

## **A Word to the End User**

The end user has sole responsibility to enforce the use of safety procedures and guards on the machine. Any other safety devices or procedures due to local regulations should be retrofitted in accordance to these regulations and/or the EC Directive on the safety of machines.

Operator's position must always be readily accessible. Escape routes must always be kept clear and safety areas should be identified.

## Safety Precautions

Safety should be a constant concern for everyone. Always be careful when working with this equipment. While normal safety precautions were taken in the design and manufacture of this equipment, there are some potential safety hazards.

**Everyone involved with the operation and maintenance of this equipment should read and follow the instructions in this manual.**

**Operate the equipment only as stated in this manual. Incorrect use could cause damage to the equipment or personal injury.**

**It is the owner's responsibility to make certain that the operator reads and understands this manual before operating this equipment. It is also the owner's responsibility to make certain that the operator is a qualified and physically able individual, properly trained in the operation of this equipment.**

Specific safety warning decals are located on the equipment near the immediate areas of potential hazards. These decals should not be removed or obliterated. Replace them if they become non-readable.

- ALWAYS keep safety shields and covers in place, except for servicing.
- ALWAYS operate equipment in daylight or with adequate working lights.
- Follow daily and weekly checklists, making sure hoses are tightly secured and bolts are tightened.
- ALWAYS watch and avoid holes or deep depressions.
- ALWAYS wear adequate eye protection when servicing the hydraulic system and battery.
- NEVER operate a poorly maintained machine.
- NEVER allow persons to operate this machine without proper instruction.
- NEVER put hands or feet under any part of the machine while it is running.
- NEVER leave machine unattended while it is running.
- NEVER attempt to make any adjustments or repairs to the machine while running. Repairs or maintenance should be performed by trained personnel only.
- NEVER work under the machine unless it is safely supported with stands, blocks or a hoist and blocks.
- NEVER touch hot parts of machine.

---

## General Machine Data

### Specifications

Electrical Requirements:	220 VAC, 3 Phase, 50/60 Hz, 15 amp
Main Motor Power:	5 hp
Max Load:	22,000 ft.-lbf (99kN)
Overall Dimensions:	L 131" x W 87" x H 152" L 3330mm x W 2210mm x H 3860mm
Max Unbaling Quantity:	20 pcs
Power Supply:	220V 50-60Hz
Upper Platform Speed:	9.84 foot/min. (3 meter/min.)

### Tools Required for Installation

#### Toolbox (Included)

12mm Allen Wrench (Included)  
14mm Allen Wrench (Included)  
Crowbar

### 1309 Footprint

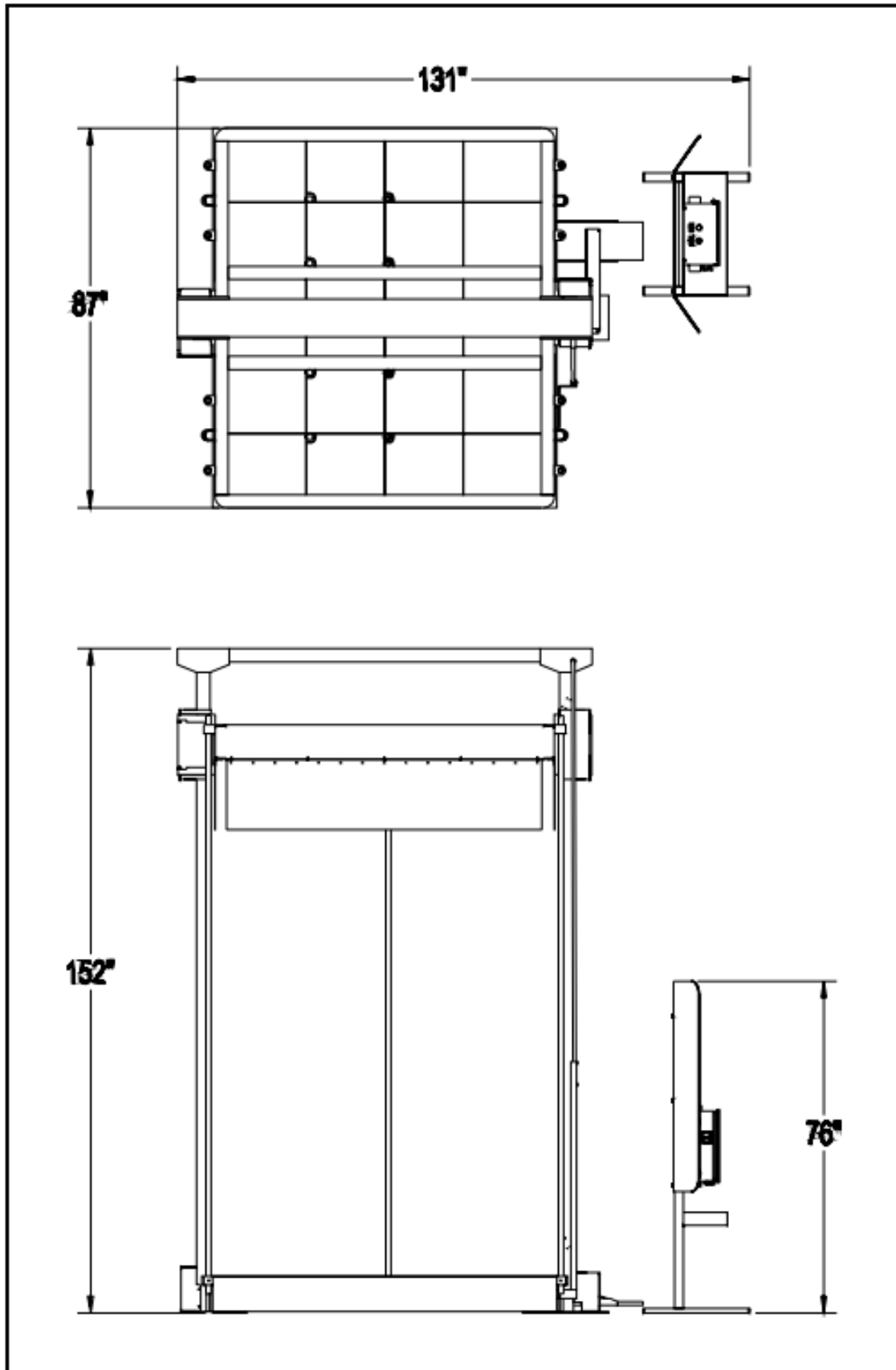
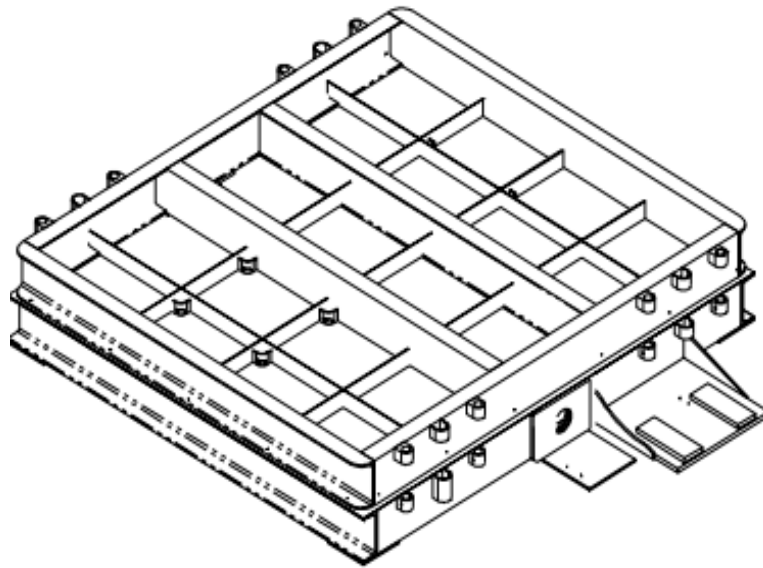

Figure 1

# Installation Instructions

Installation should be performed by a qualified mechanic.



**Step 1:**

Place the lower platform on a flat, level area of the floor. Ensure there is enough room around the machine for spring loading and discharge.

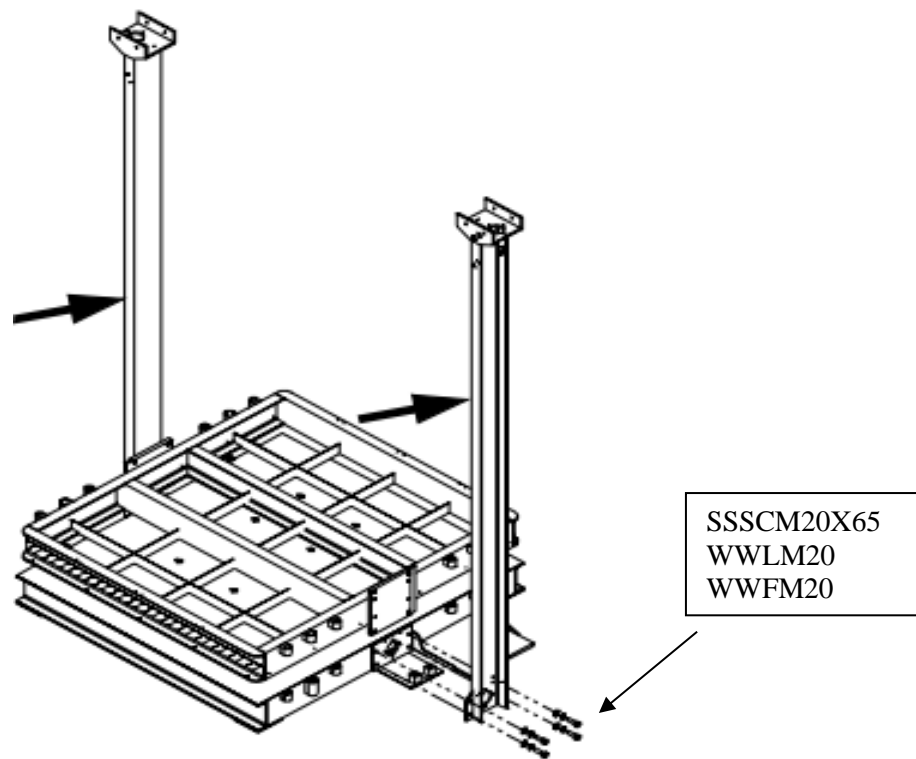

**Step 2:**

Mount the (2) Side Beams to the Lower Platform. **The screws should be torqued to 150 lbf ft.**

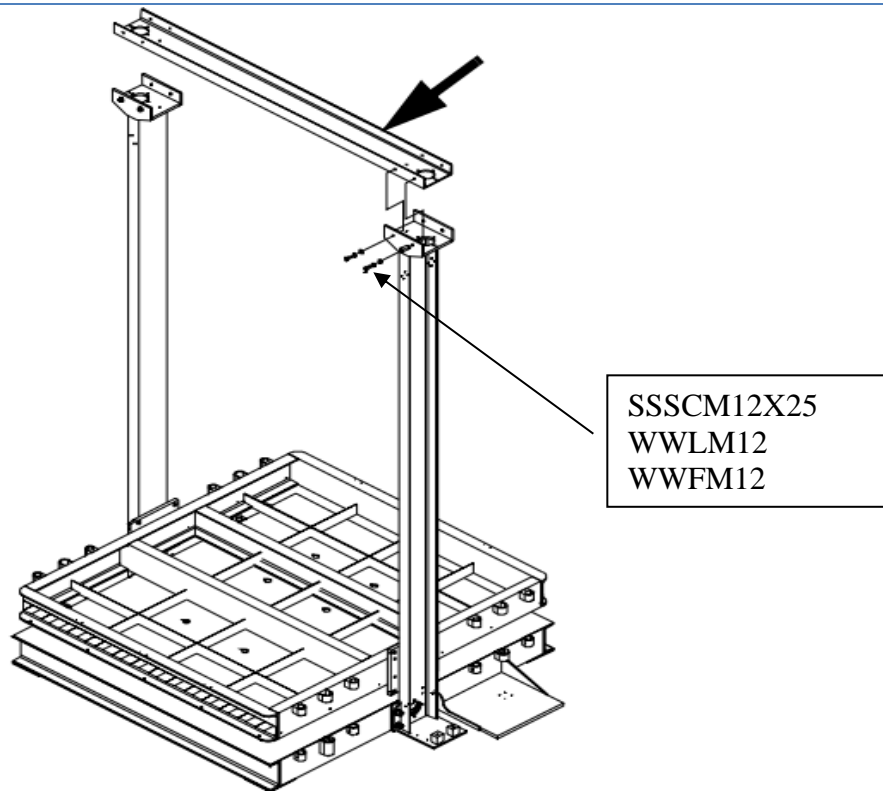

**Step 3:**

Install the Top Support Beam to the Side Beams. **The screws should be torqued to 70 lbf ft.**

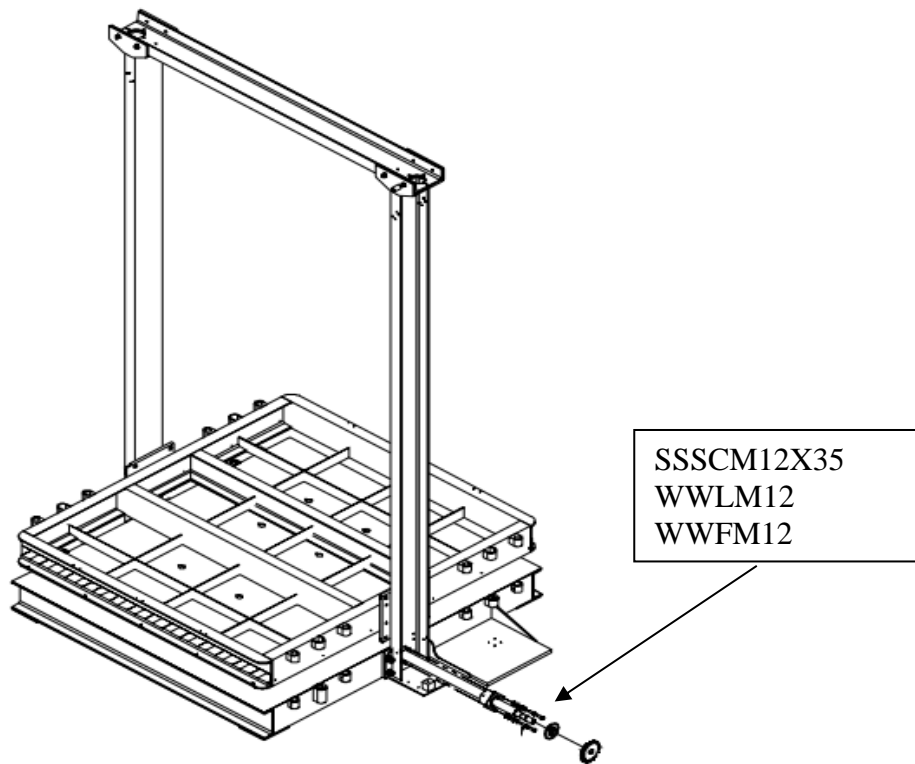

**Step 4:**

Insert the Drive Shaft thru the hole in the Bottom Platform. Install the gears on both ends. **The screws should be torqued to 70 lbf ft.**

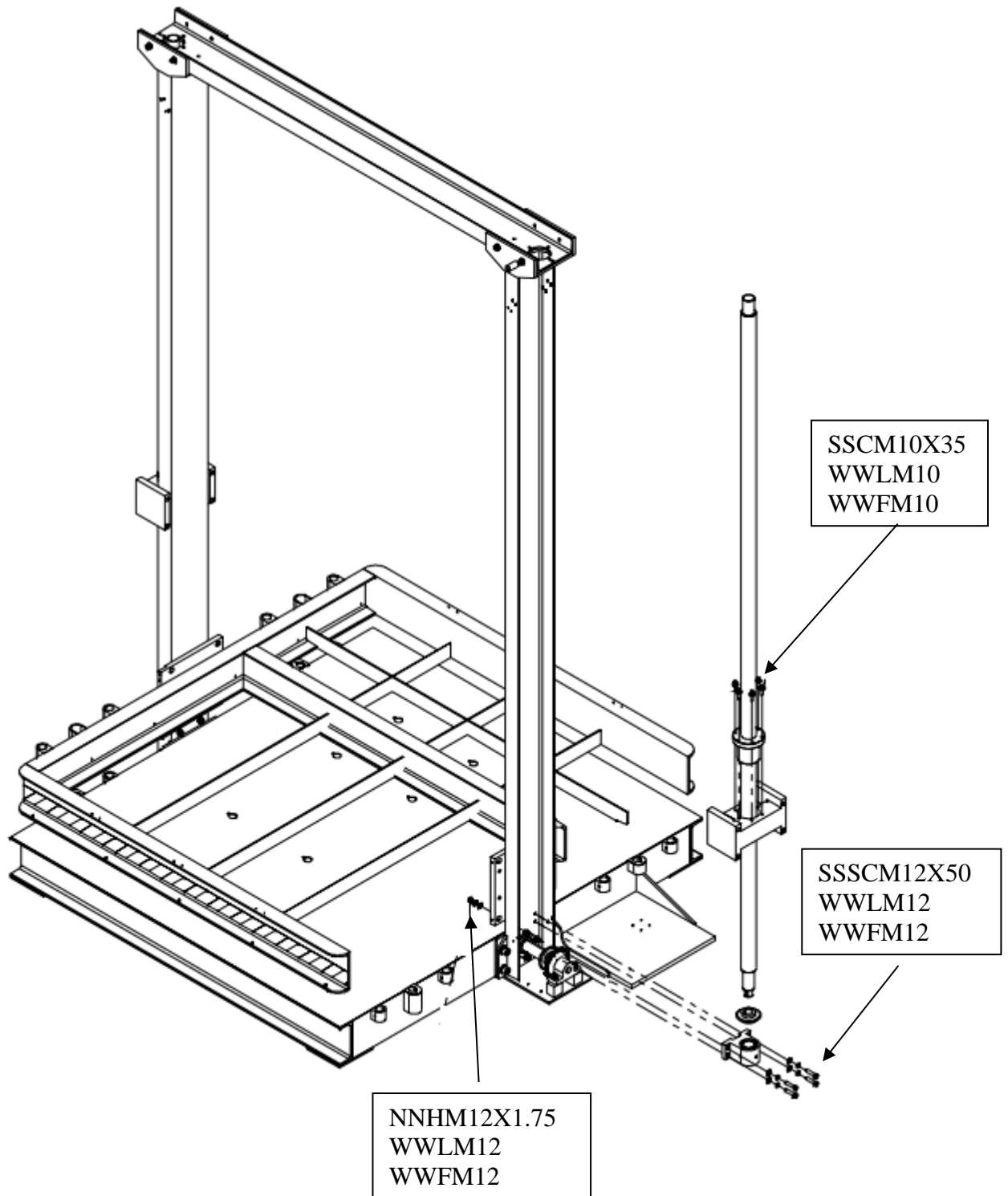

**Step 5:**

Mount the Lead Screw assembly to the Side Beam by inserting the top end thru the hole in the Top Support Beam and fastening the (4) 12mm screws thru the bearing at the lower end of the Lead Screw assembly to the tapped holes in the Side Beams. **The screws should be torqued to 70 lbf ft. Tighten the (2) 12mm nuts to 50 lbf ft.**

Repeat this step on the opposite side.

**Important:**

Be sure the distance from the lower bearing on the Lead Screw assembly to the section that mounts to the upper platform is the same on both sides. This ensures the upper and lower platforms will be parallel.

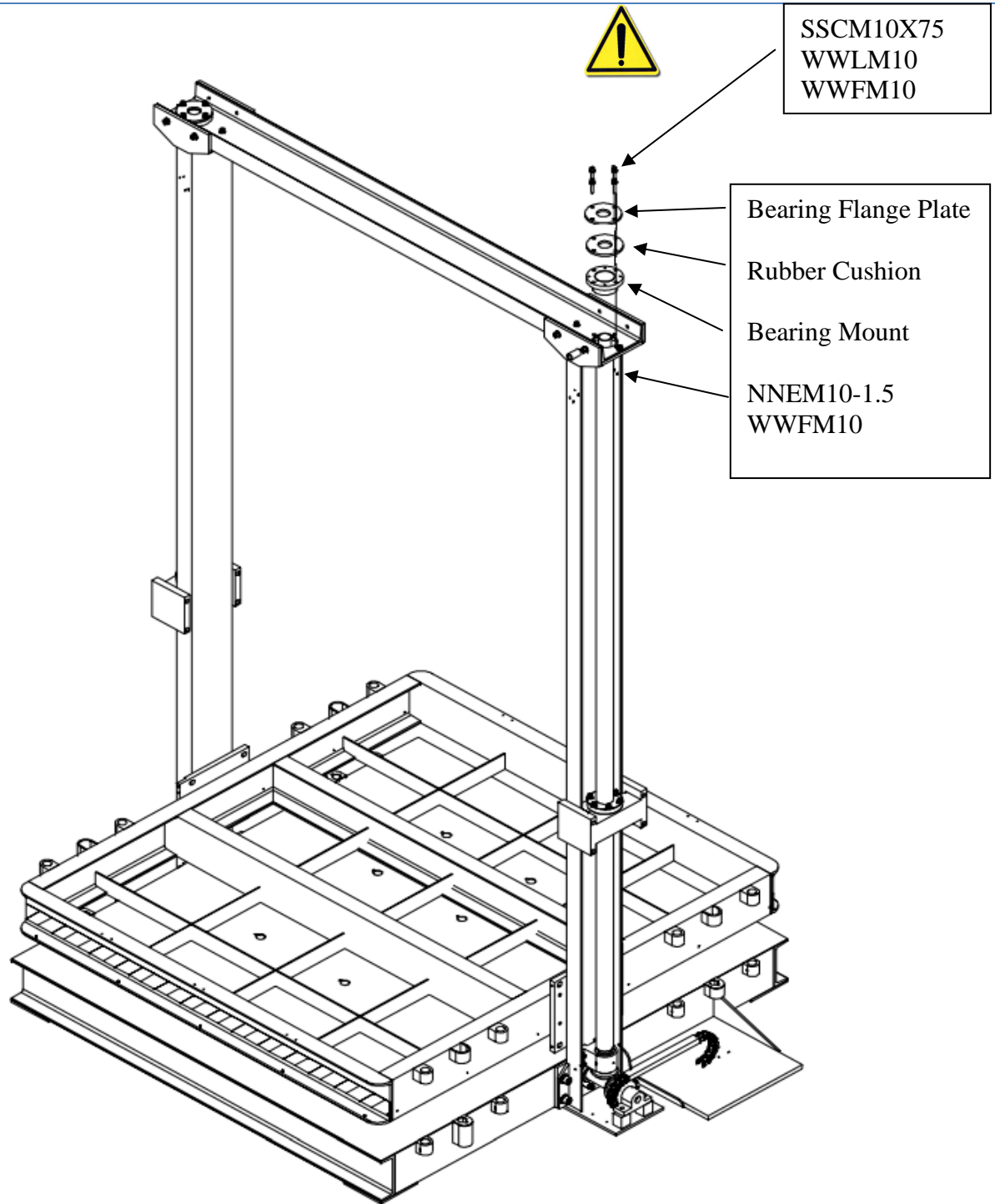

**Step 6:**

Install the bearing mounts, rubber cushions and the bearing flange plates on both sides.



**IMPORTANT!**

The screws (SSSCM10X75) should tighten just until the lock washers (WWLM10) are fully compressed. **The lock nuts (NNEM10-1.5) should be torqued to 50 ft./lbs.**

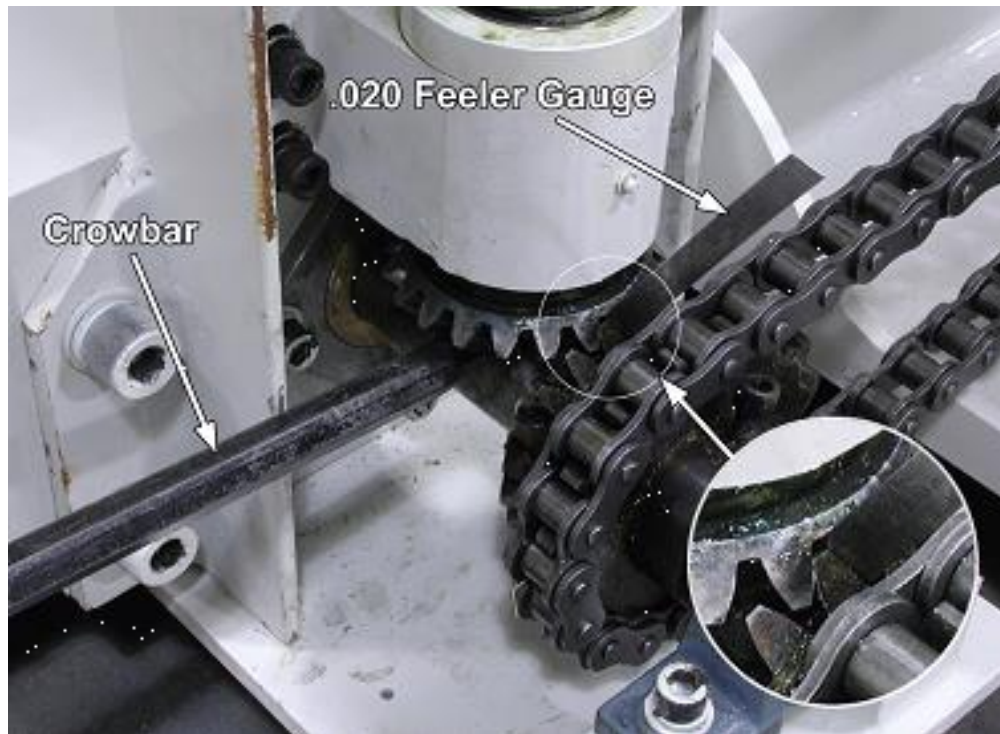

**Step 7:**

Loosen the 4 mounting screws on the lower end of the Lead Screw assembly. Using a crowbar, lift the Lead Screw assembly until there is approx. .020" gap between gear teeth. The beveled surfaces of the two gears should be flush as shown below. The 4 mounting screws should be torqued to 70 lbf ft.

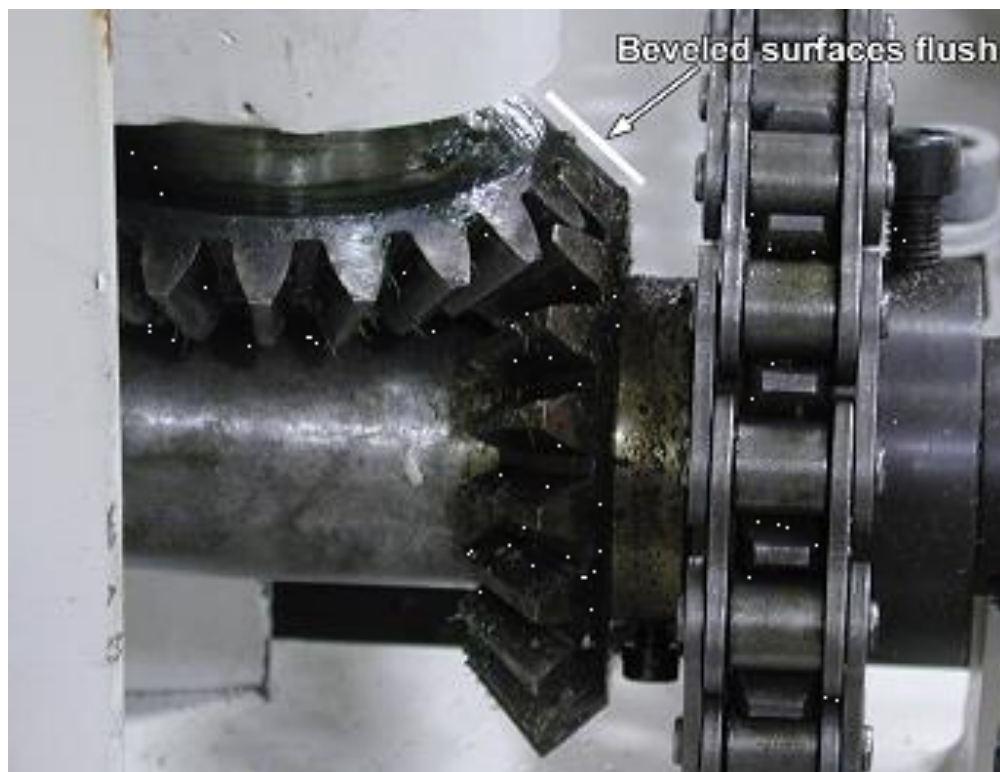

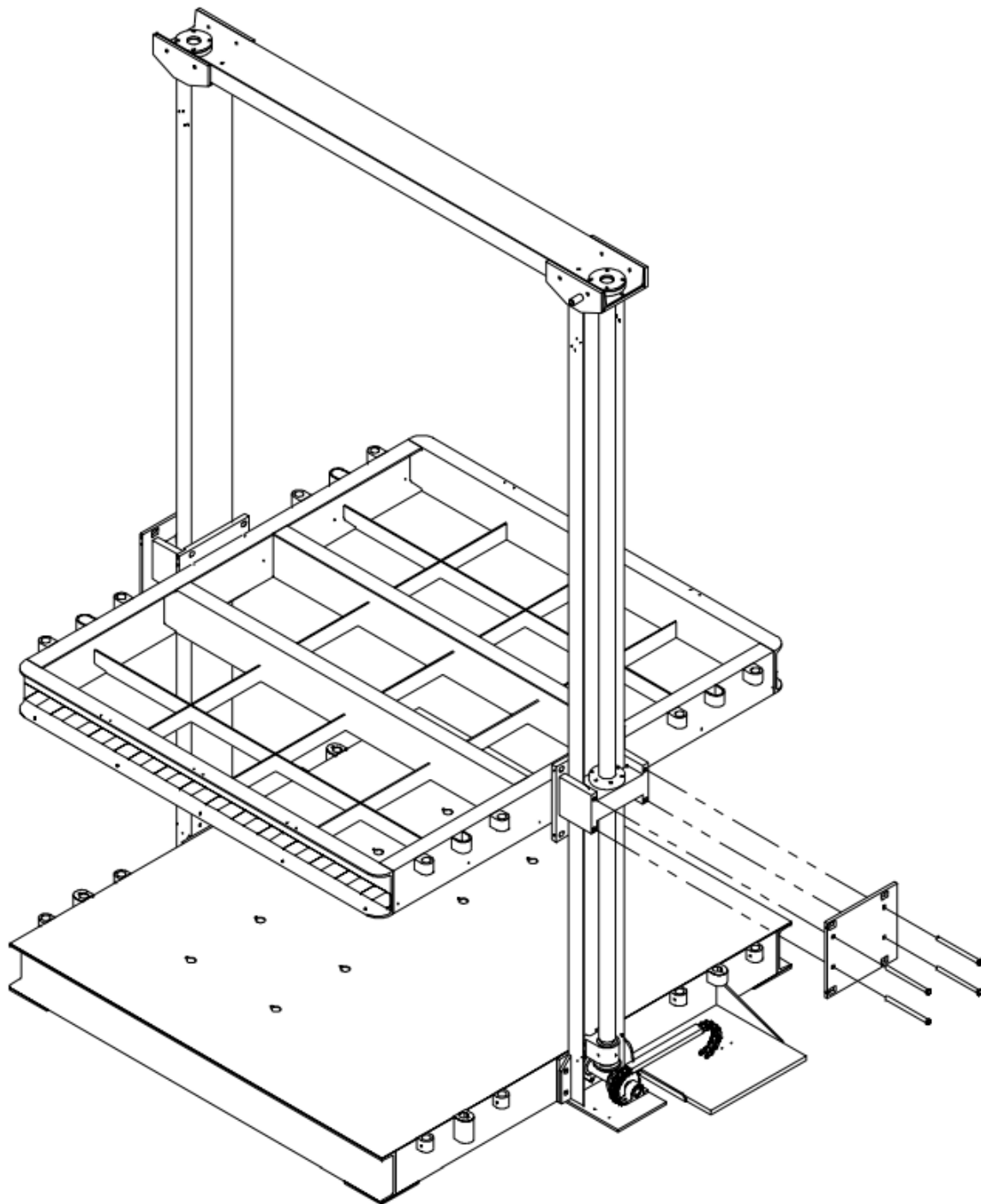

**Step 8:**

Using the M16 X 220MM screws provided, fasten the Side Plate to the top platform. Repeat this on the other side of the machine. **The screws should be torqued to 110 lbf ft.**

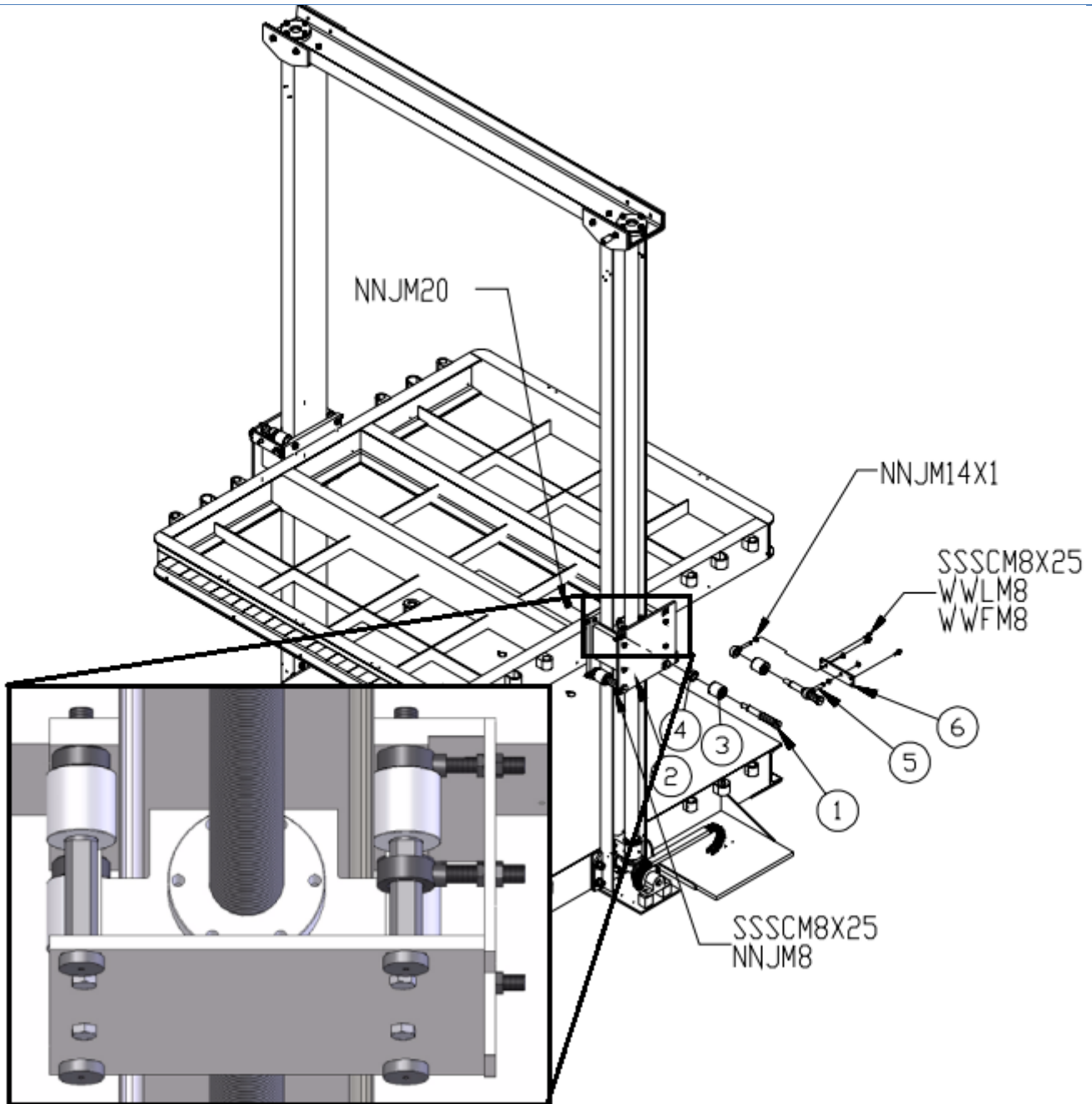

**Step 9:**

Insert Shoulder Bolt (1) thru the top left slot in the Side Plate (2). Insert the Roller (3) and Spacer (4) on the Shoulder Bolt as shown above. Repeat this using the lower left slot in the Side Plate.

**Step 10:**

Insert Shoulder Bolt (1) thru the top right slot in the Side Plate (2). Position the Guide Pins (5) and Roller (3) as shown. Mount the Washer Plate (6). Repeat this using the lower right slot in the Side Plate. **The 8mm screws should be torqued to 30 lbf ft.**

Repeat steps 9 and 10 on the other side of the machine.

Level the upper platform from front to back. See “Leveling the Upper Platform Front To Back” on page 32.

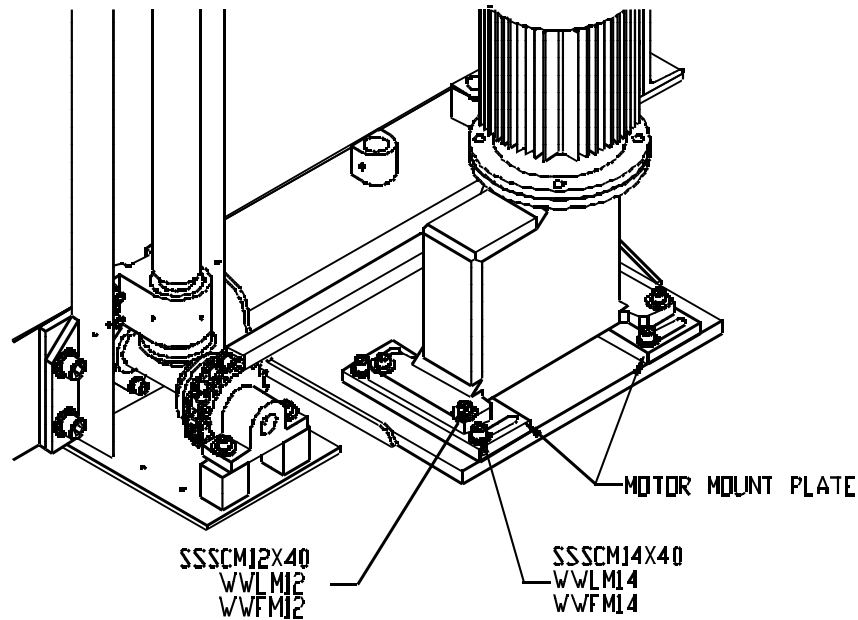

**Step 11:**

Check oil level in gear box. Use 85-90w gear oil. Install the motor to the motor mount plate as shown. Use the slots to adjust the tension of the drive chain. **The 12mm screws should be torqued to 105 lbf ft. The 14mm screws should be torqued to 165 lbf ft.** Stop if thread seems to be stripping.

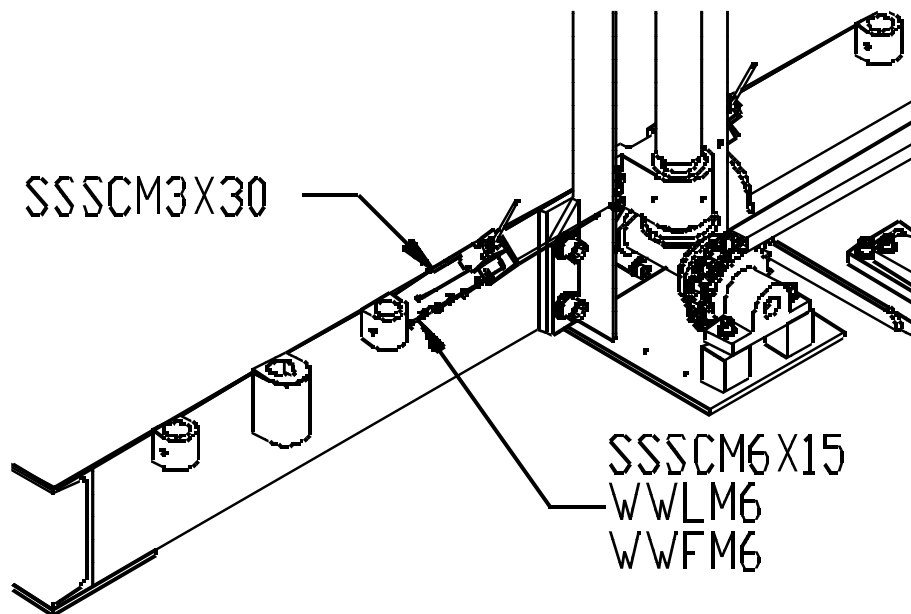

**Step 12:**

Secure the Lower Limit Switches using the bolts provided to the tapped holes in the side beam on the motor side.

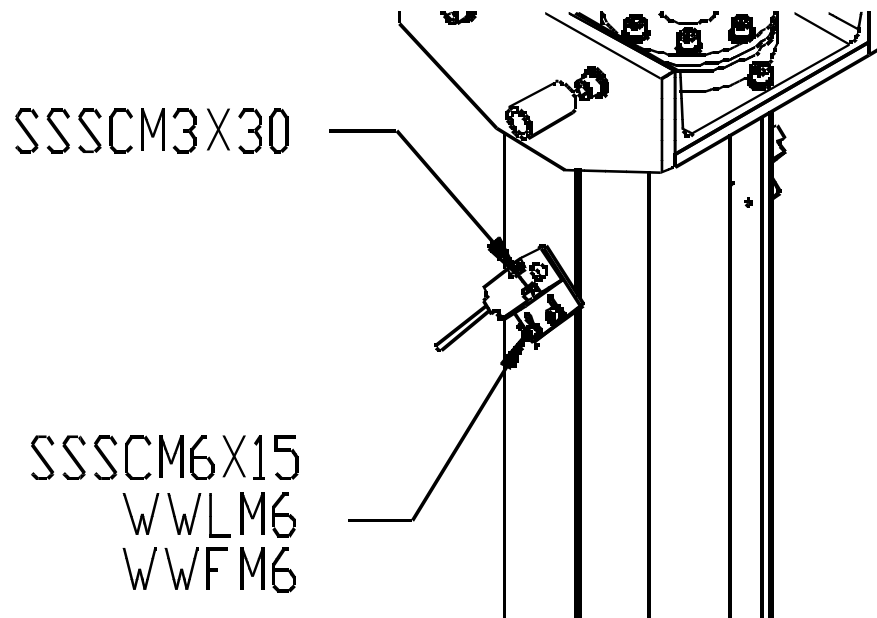

**Step 13:**

Secure the Upper Limit Switches using the bolts provided to the tapped holes in the side beam on the motor side.

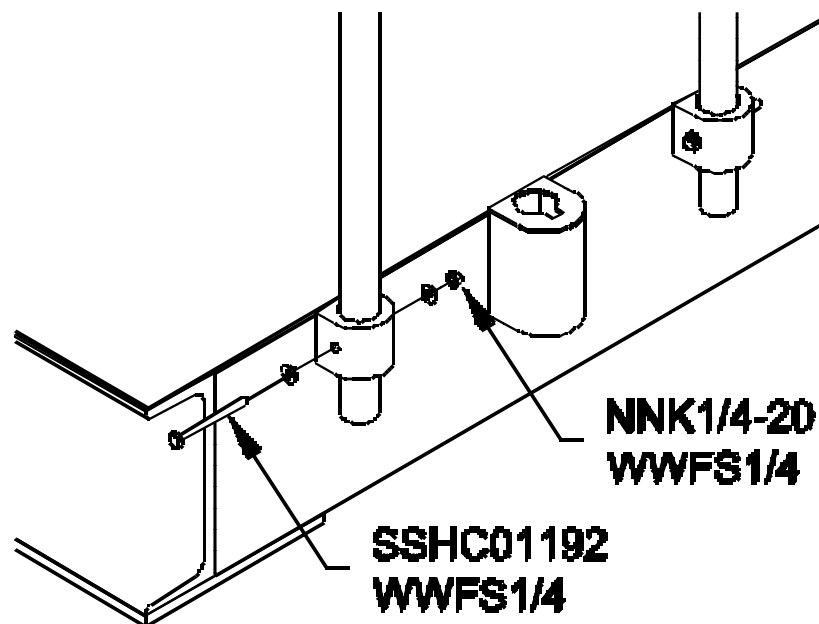

**Step 14:**

Insert the (8) poles thru the guide rings in the top platform. Use the supplied bolts (1/4-20 x 2-3/4") and lock nuts to secure the poles to the guide ring in the lower platform.

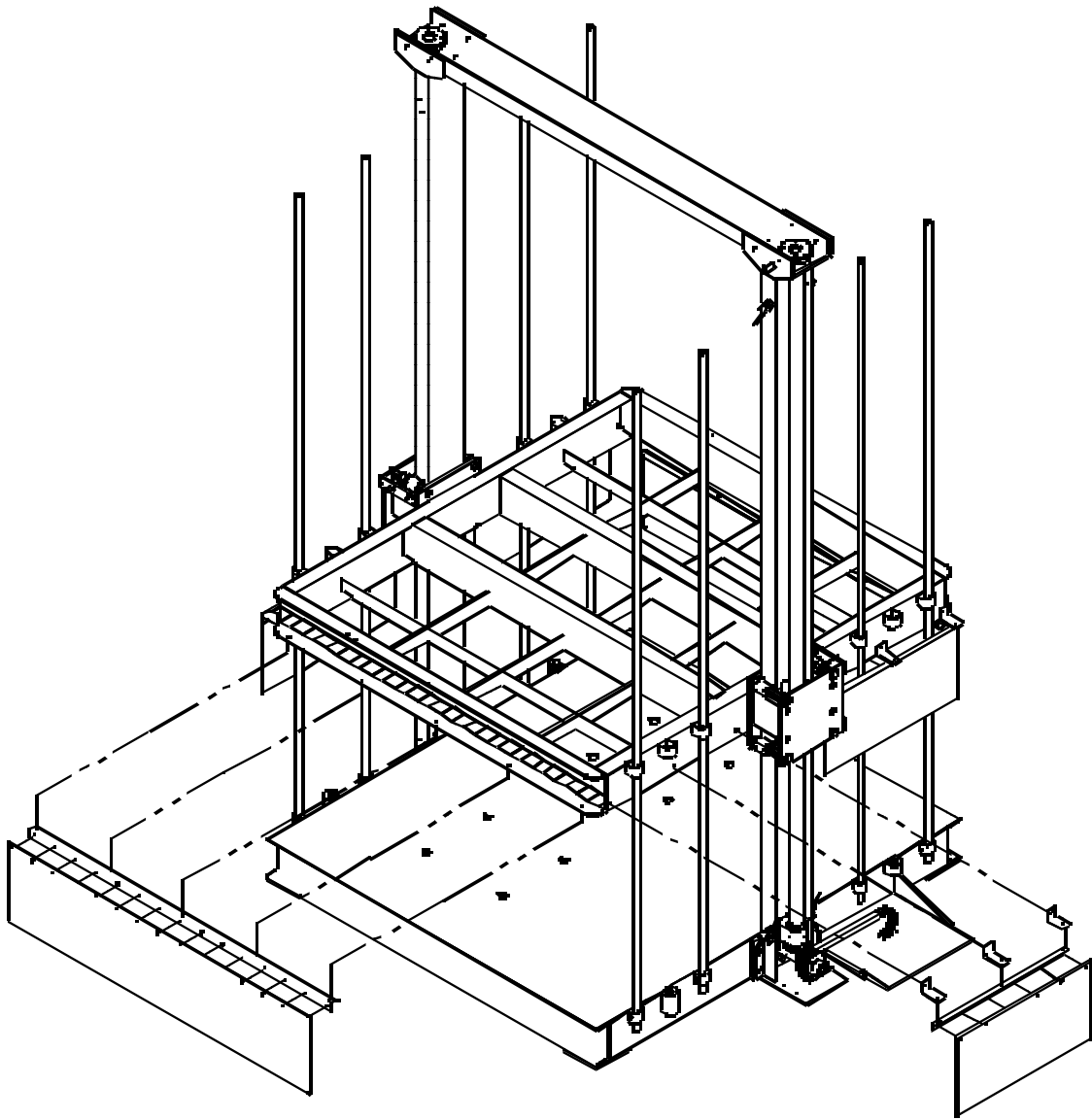

**Step 15:**

Using the brackets and hardware provided, install the vinyl guards as shown above.

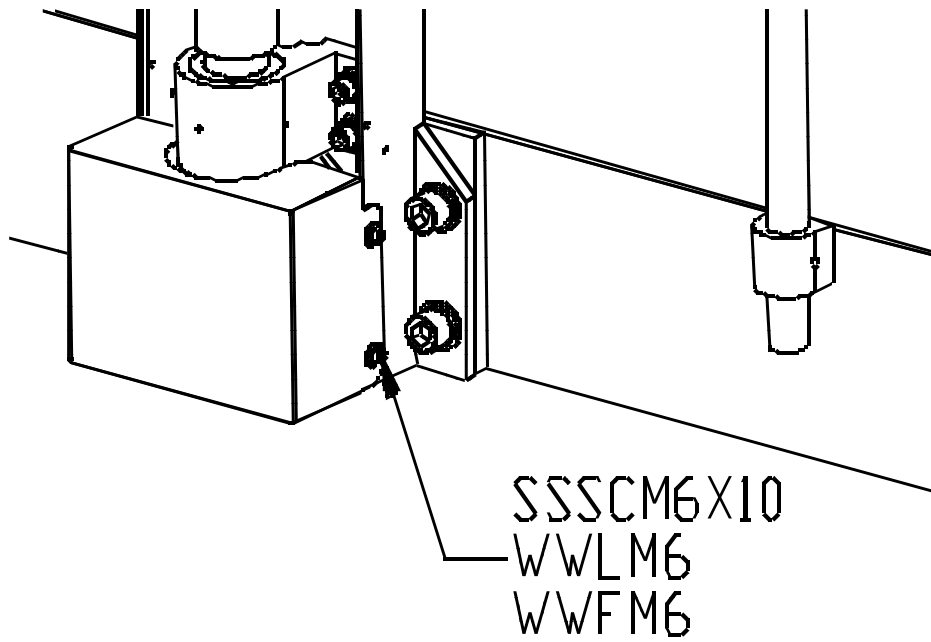

**Step 16:**

Install the gear guard on the side opposite of the motor as shown above.

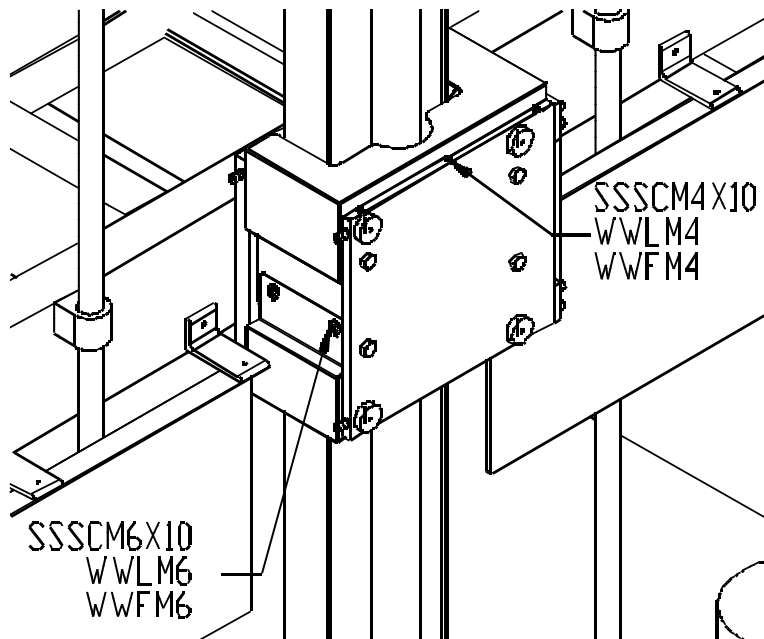

**Step 17:**

Install the top roller guards and bottom roller guards on both sides of the machine as shown above.

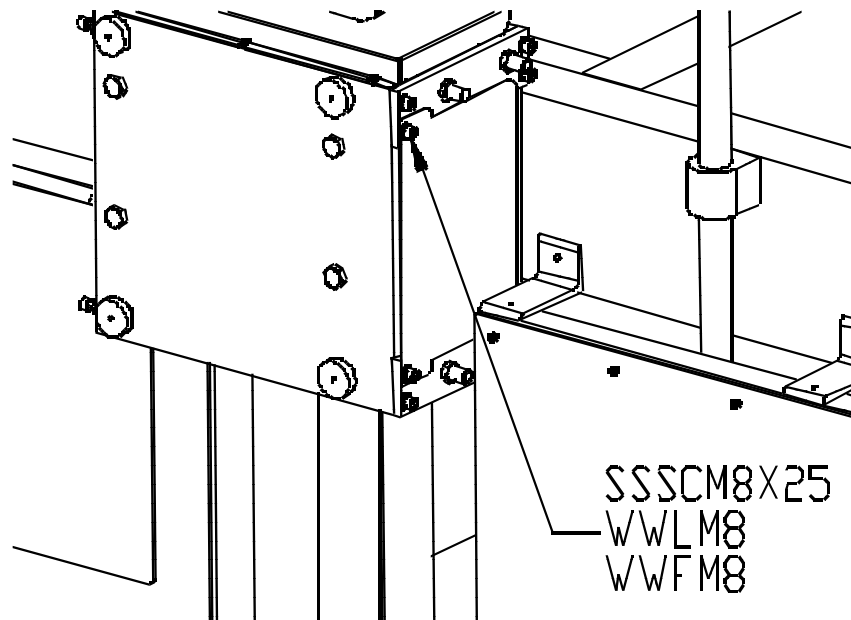

**Step 18:**

Install the side guards on both sides of the machine as shown above.

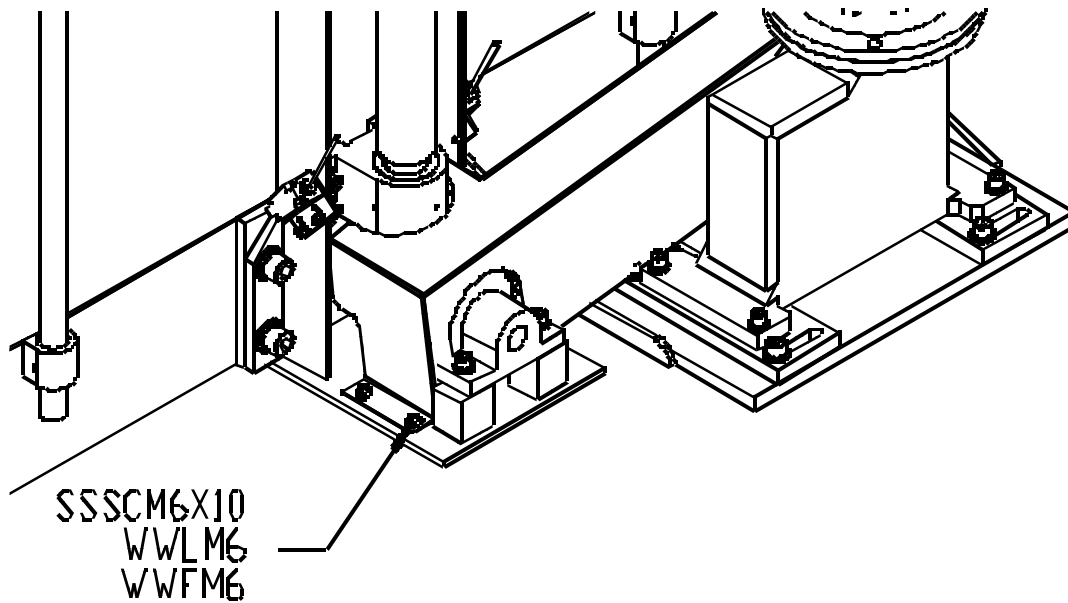

**Step 19:**

Install the chain guard.

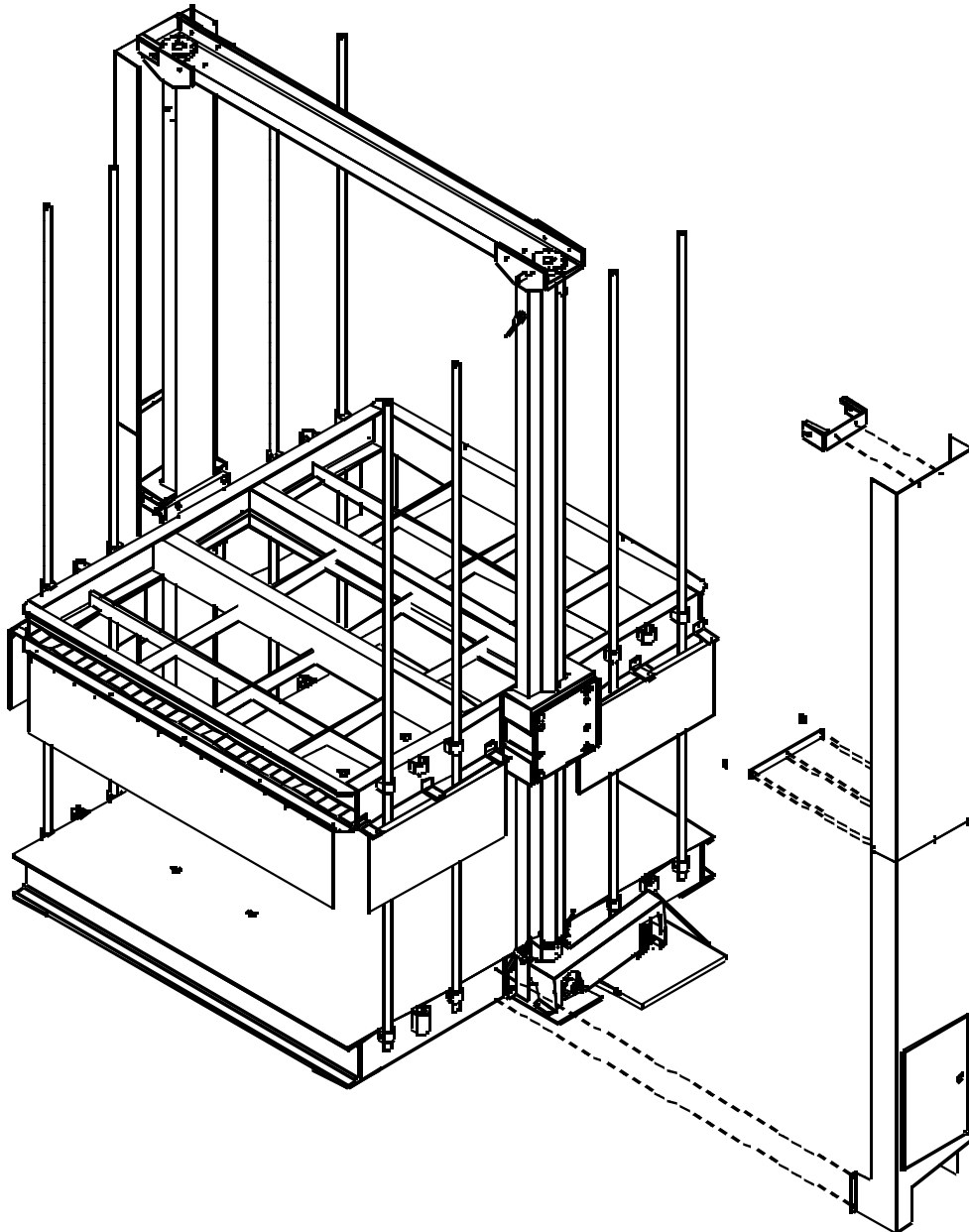

**Step 20:**

Install the tall screw guard's assemblies on both sides of the machine.

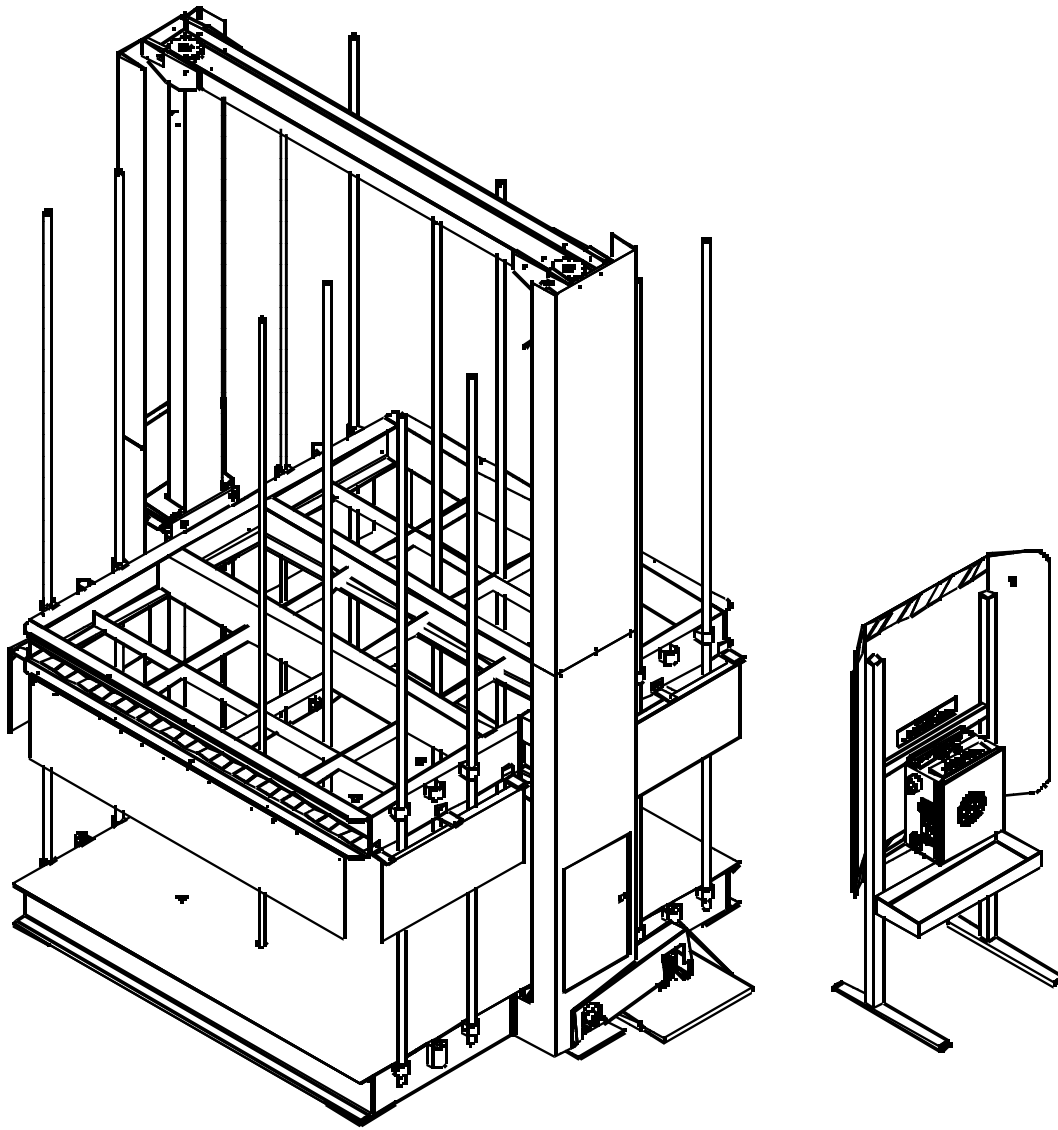

**Step 21:**

Position the Control Unit and connect the motor according to the wiring diagram on 45.

**Step 22:**

Connect the main power.

**This machine requires 220 VAC, Three Phase, 50/60 Hz, 16 amp, 3700 watts.**

**Step 23:**

Turn the machine on.



**Step 24:**

Using the control panel, lower the upper platform until it measures 6 inches from the lower platform on the opposite side of the motor. Next, measure the distance on the motor side. If it does not measure 6 inches, refer to “Leveling The Upper Platform Side To Side” on page 29 in order to make the upper and lower platforms parallel before proceeding/

## Leveling the Upper Platform Side to Side

**Important:** You must disconnect the power to the machine before making this adjustment.



- 1.) Loosen the 4 bolts in the slots which secure the motor to the motor mount plate.
- 2.) Remove the chain from the motor sprocket.

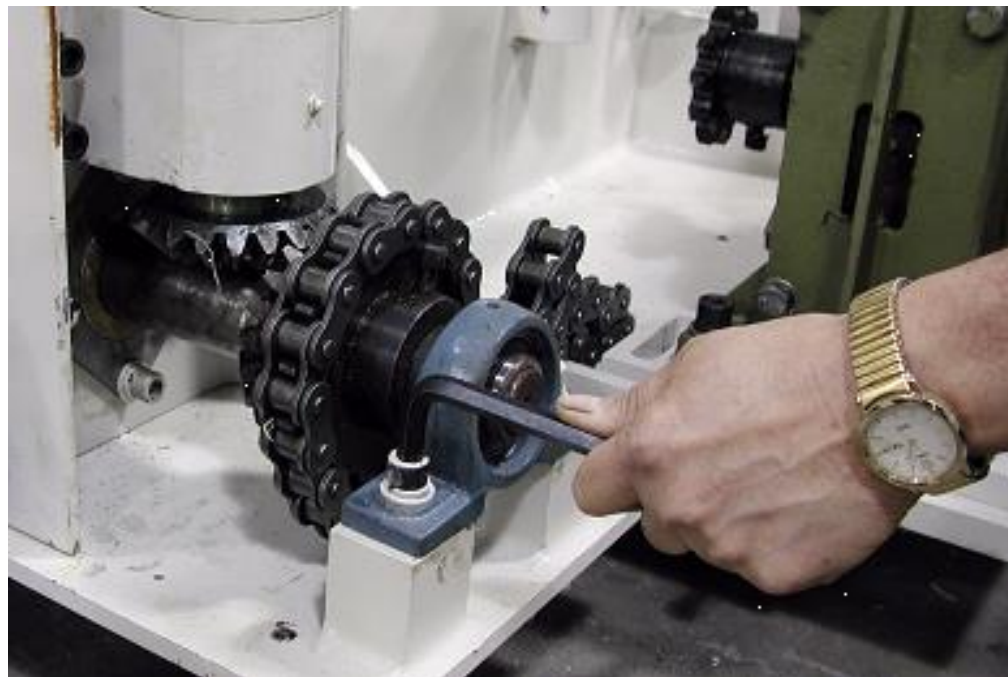

- 3.) Remove the 2 bolts which secure the drive shaft bearing.



- 4.) Loosen the set screw in the collar behind the drive shaft bearing.
- 5.) Using a pulley puller, remove the drive shaft bearing and collar.
- 6.) Loosen the screw in the driven sprocket.



- 7.) Using a pulley puller, pull the sprocket approx. 1" towards the end of the shaft.
- 8.) Loosen the screw in the beveled gear.

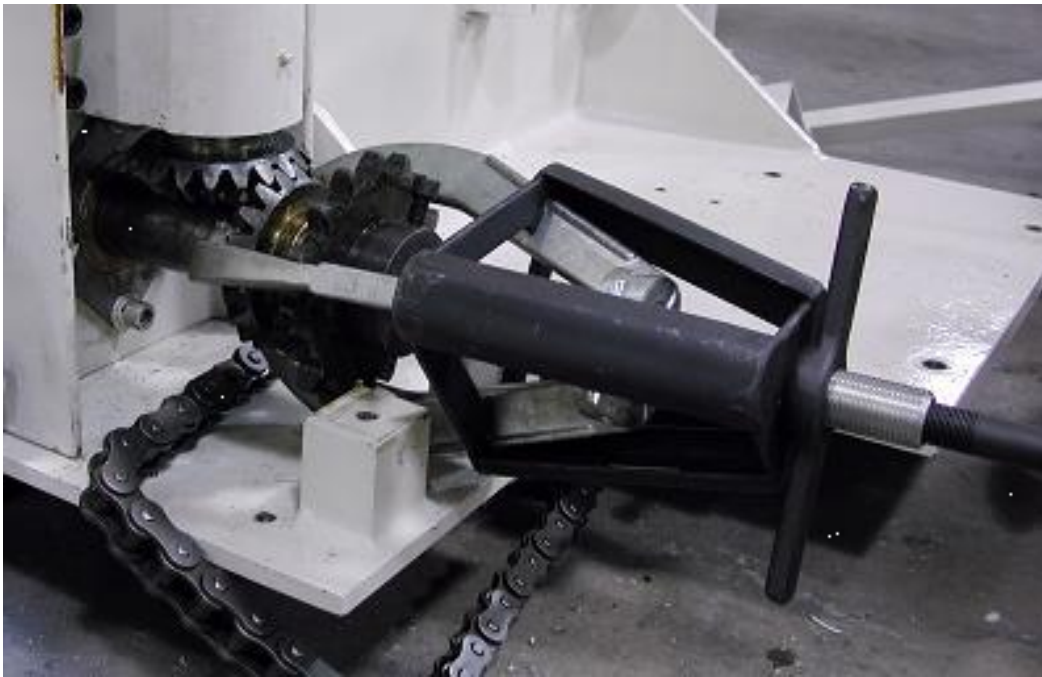

9.) Using a pulley puller, pull the gear until it is no longer meshed with the mating gear.

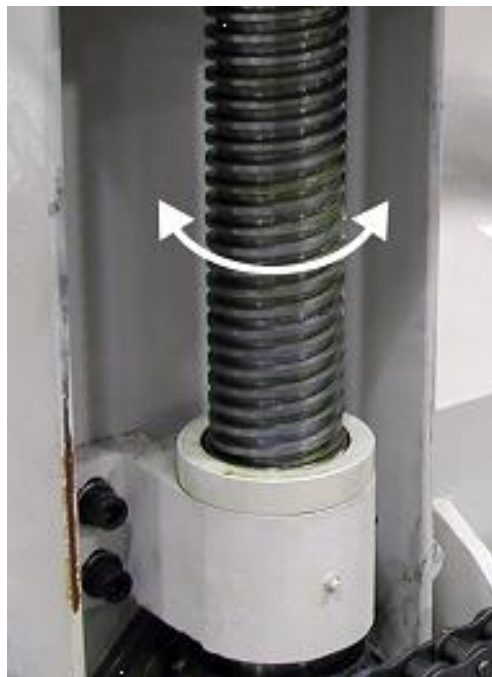

10.) Turn the Lead Screw assembly until the upper and lower platforms are parallel.  
- Clockwise lowers the motor side of the upper platform.  
- Counter clockwise raises the motor side of the upper platform.

## Leveling the Upper Platform Front to Back

Measure the distance between the upper and lower platforms on both the front and back of the machine. If these two measurements are the same, the platform is level from front to back. If the measurements are not the same, use the adjustment screws (shown below) to tilt the upper platform until it is level.



Once the upper platform is level from front to back, adjust the locking nuts (shown below) until the idler roller is resting on the side beam. Tighten the locking nuts.



Repeat these steps on the other side of the machine.

## Solving Binding Issues

If the two Lead Screw assemblies are not parallel the machine may bind when the upper platform is being raised or lowered. Use the following instructions below to relieve any binding.

- 1.) First, verify that the distance between the upper and lower platforms is the same on both sides. Refer to “Leveling the Upper Platform Side To Side” on page 30.
- 2.) Second, verify that the distance between the upper and lower platforms is the same on both the front and back of the machine. Refer to “Leveling the Upper Platform Front to Back” on page 30.
- 3.) Position the upper platform approximately halfway between the upper and lower limits of the Lead screws.
- 4.) Turn the “Current” dial in the control box counterclockwise until the red “Fault” light comes on. Now turn the “Current” dial clockwise until the red “Fault” light goes off.



- 5.) Begin lowering the upper platform. If the upper platform lowers all the way until it reaches the lower limit switches without the red “Fault” light coming on there is no bind.

If the red “Fault” light comes on there is a bind and a shim will need to be inserted between the lower bearing mount of the Lead Screw and the Side Beam on the side opposite of the motor as shown in the picture below.

**Warning!**

**Disconnect the power source before inserting shim.**



6.) After the shims have been inserted, reconnect the power source. Repeat steps 3 thru 6. Thicker shims may be required if binding still occurs.

After shims have been installed and binding no longer occurs, turn the “Current” dial back to the “10 o’clock” position as shown in the photo below.



## Operating Instructions

Before each shift, lubricate all gears, the chain and the two Lead Screws.

The Lead Screws require special lubrication. Use Acme Screw Grease (NLU-2001).

- 1.) Turn the Main Power switch to the on position.
- 2.) Turn the “Direction Selector” to the “Up” position.
- 3.) Press and hold both “Motion Control” buttons to raise the upper platform to allow clearance for the spring block.
- 4.) Turn the power off.

### Warning!

**Never load a spring block onto the lower platform with power on.**

- 5.) Place the spring block onto the lower platform. King and Queen sizes should be centered on the platform. Twin and Full sizes should be placed against the near side exposing the inner guard tube holes. On twin sizes, install the four inner guard tubes into the center row of holes in the lower and upper platforms. On full sizes, install the four inner guard tubes into the offset row of holes in the lower and upper platforms. Be sure that both locking tabs on the tubes are below the lower platform plate.
- 6.) Turn on the power. Switch the “Direction Selector” to the “down” position. Press and hold both “Motion Control” buttons to lower the upper platform until it is touching the spring block or until the lower limit switches are made.
- 7.) Carefully cut the steel straps holding the spring block together.

### Warning! Do not stand on the upper platform!

- 8.) Turn the “Direction Selector” to the “up” position. Press and hold both “Motion Control” buttons to raise the platform until the springs are completely decompressed.

**Stay at least 2 meters/6.5 feet away from machine during the unbaling process.**

Turn off the power and remove the springs from the machine.

**Do not remove the spring units from the platform until they are fully unbaled.**

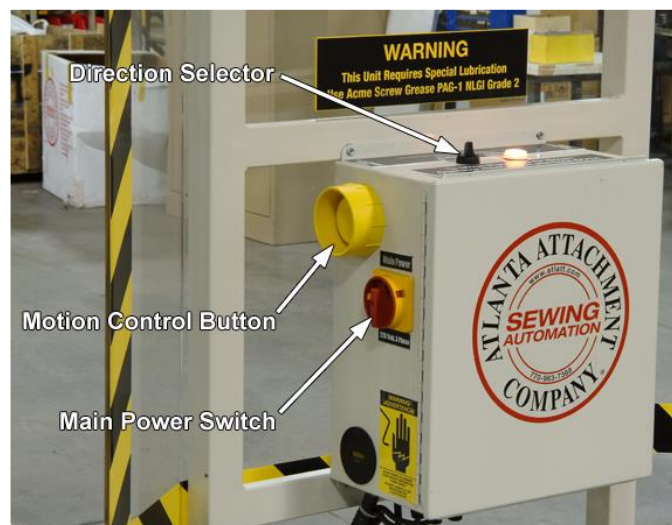

## Machine Maintenance

Maintenance should only be performed by trained, qualified personnel. Before performing any maintenance or repair work, switch off the electrical, pneumatic, etc. power to the machine at the main source and secure it with a padlock so that it cannot be switched on again without authorization. Always wear proper safety equipment when operating or performing maintenance on any equipment. All recommended maintenance is for a single shift schedule; adjust as necessary for a multi-shift operation.  
Equipment should not be used for purposes other than designed or specified.

### Daily (8 -10 hrs. of operation)

Follow manufacturer's recommendations and guidelines for operation and maintenance.  
Check for proper oil level in all oil filled or lubed components, fill as needed. Oil all points as indicated.  
Clean the machine at the end of every shift or as excess materials accumulate.  
Clean lint, waste, etc. from all areas as it accumulates, remove or open covers as necessary for access.  
Remove any material(s) wrapped around or between any moving parts.  
Wipe all photocell lenses with a clean non-abrasive dry cloth.  
Open or remove doors and/or covers and inspect chains for debris or wear and clean or replace as necessary.  
Investigate and report any unusual noises to the proper personnel.

### Weekly (40 hrs. of operation)

Check the drive chain for proper tightness and wear. Adjust and replace as necessary.  
Inspect photocell reflective tape, i.e. (machine handwheel, etc.) and replace if dirty or worn.  
Inspect all electrical and mechanical switches.  
Inspect all moving parts to ensure smooth operation, lube or clean as necessary.

### Monthly (160 hrs. of operation)

Inspect pillow blocks and other non-sealed bearings and rotating shafts and apply a enough recommended grease to each bearing/fitting.

## Assembly Drawings & Parts Lists

The materials contained herein are confidential and proprietary information of Atlanta Attachment Company. In addition to any confidentiality and non-disclosure obligations that currently exist between you and Atlanta Attachment Company, your use of these materials serves as an acknowledgment of the confidential and proprietary nature of these materials and your duty not to make any unauthorized use or disclosure of these materials.



**One-Stop Shopping**  
For Expendable Replacement Parts for AAC & Other Bedding Equipment Suppliers  
Toll Free: **1-866-885-5100**  
[www.atlantapartsdepot.com](http://www.atlantapartsdepot.com) • [sales@atlantapartsdepot.com](mailto:sales@atlantapartsdepot.com)

# 11309 Main Assembly

AAC Drawing Number 9001367 Rev4

Main Assembly  
Complete view

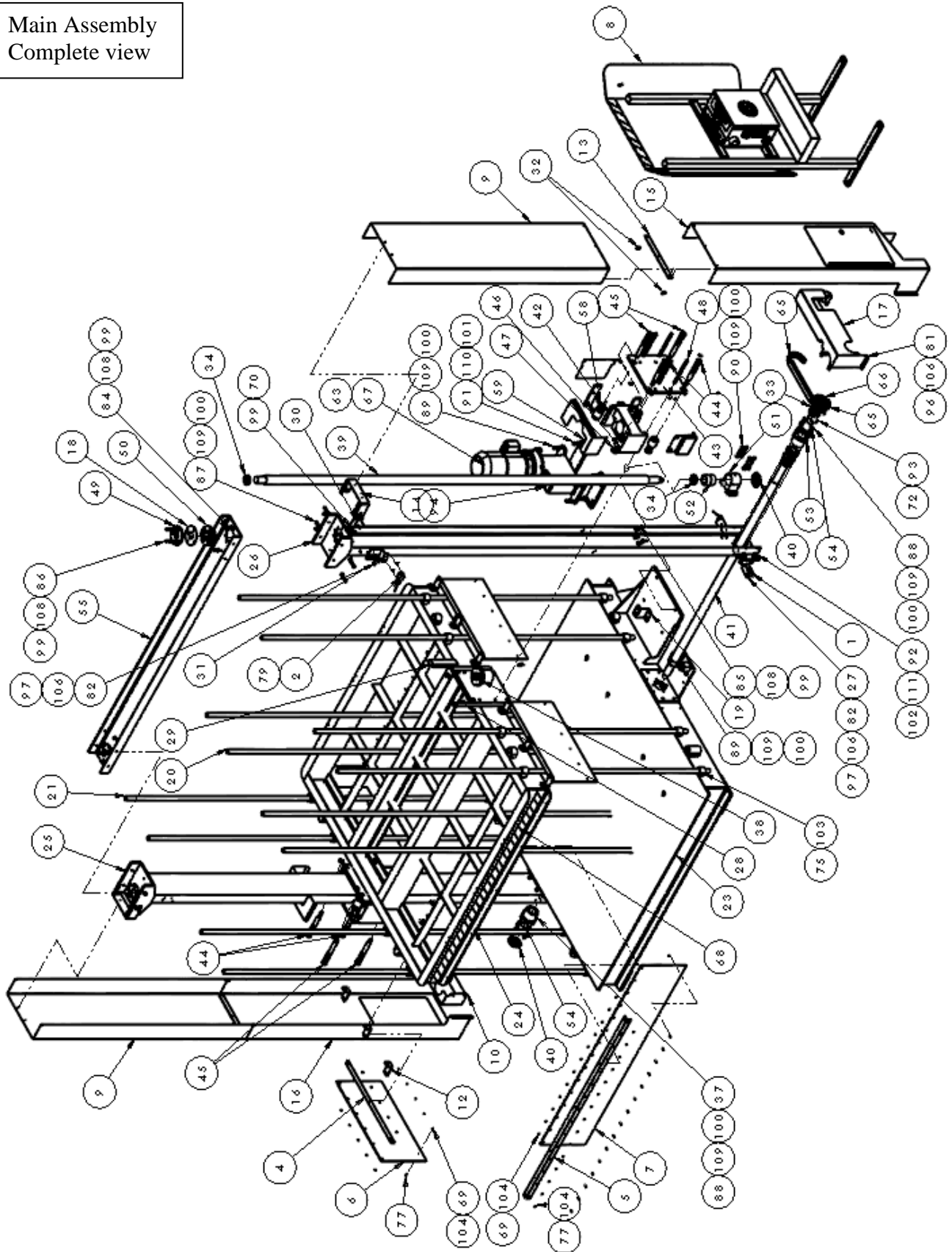

Exploded main view  
left side

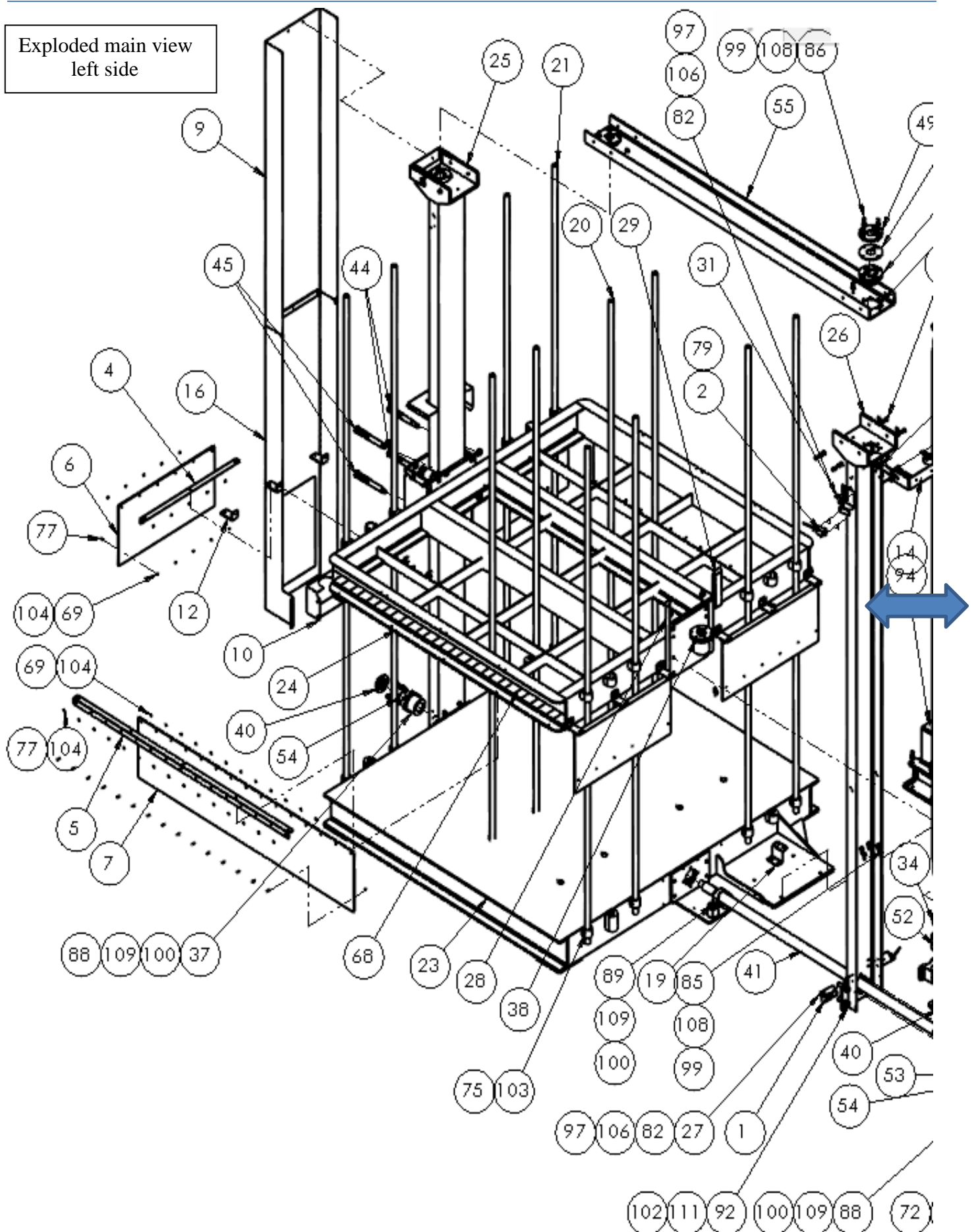

Exploded main view  
right side

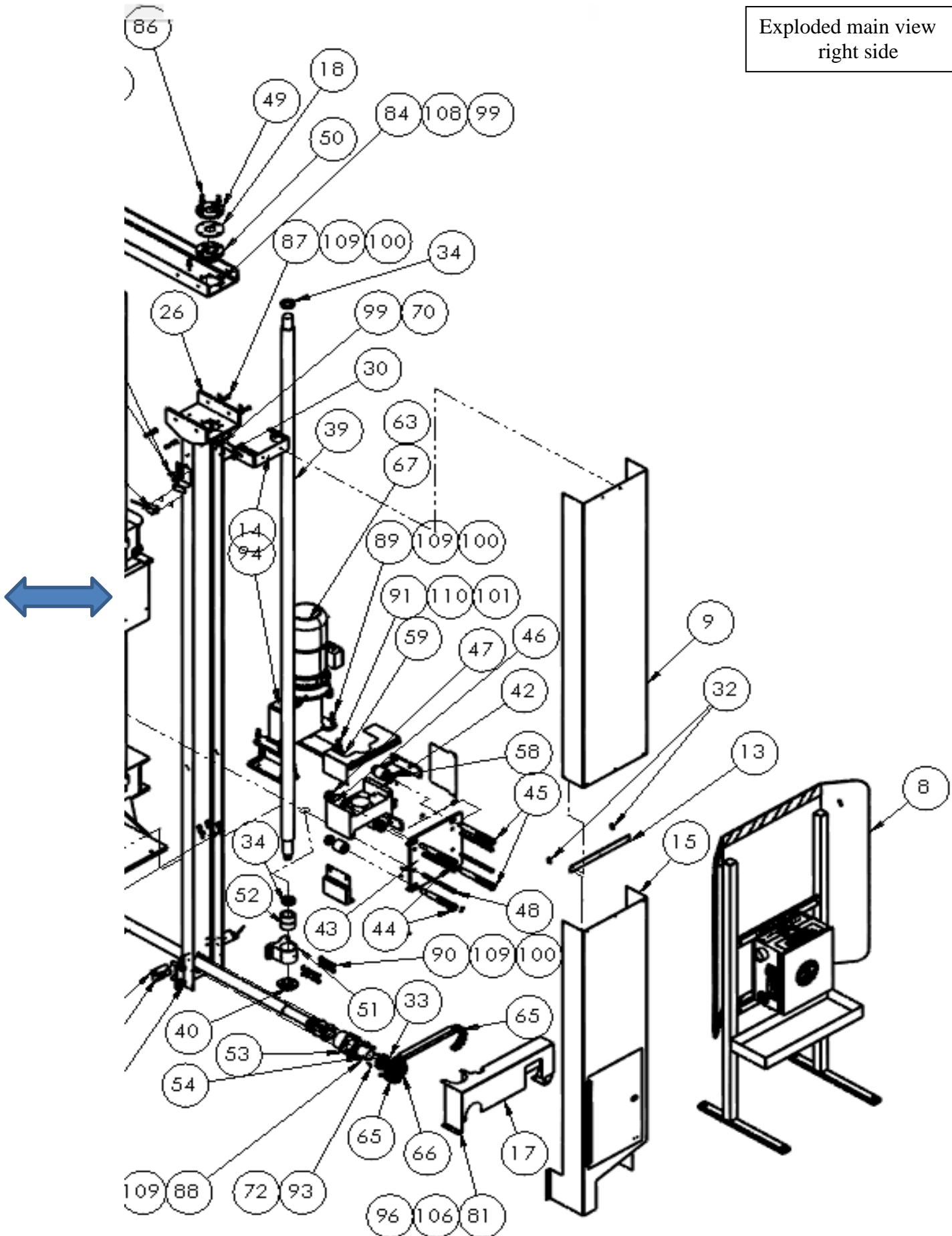

1309 parts list

ITEM NO.	HARDWARE SHOWN/QTY.	PART NUMBER	DESCRIPTION
1	1	1309-15	LIMIT SWITCHES,PAIR,18
2	1	1309-16	LIMIT SWITCHES,PAIR,32
3	1	1309-WD4	WIRING DIAGRAM, BRAKE
4	4	1309005	HANGER, GUARD, SMALL
5	2	1309006	HANGER, GUARD, LARGE
6	4	1309007	GUARD, VINYL, SMALL
7	2	1309008	GUARD, VINYL, LARGE
8	1	1309015	OPERATOR STATION
9	2	1309021	GUARD,VERTICAL, TOP
10	1	1309025	COVER,GEAR,1309
11	2	1309026	COVER,ROLLER
12	12	1309031	ANGLE TAB, SHIELD HANGING
13	2	1309032	NUT PLATE, GUARD, VERTICAL
14	2	1309034	MOUNT, GUARD, UPPER
15	1	1309036	GUARD ASSY,BOTTOM RIGHT
16	1	1309037	GUARD ASSY,BOTTOM LEFT
17	1	1309040	GUARD,CHAIN 20 TO 17
18	2	1309045	RUBBER,1/4"
19	1	1309046	STAND UP BRACKET
20	4	1309105	POLE, 1-1/4 X 11 FT,
21	8	1309106	TUBE, 1-1/4 X 11 FT
22	1	1309108	CAP, BEARING BOX
23	1	1309110	LOWER PLATFORM MODS
24	AR	1309500	UPPER PLATFORM
25	AR	1309529	BEAM WELDMENT, MO
26	AR	1309530	BEAM WELDMENT, MOD
27	2	1309535	BRACKET,LIMIT SWITCH
28	1	1309605	FLAG, UP SW, LEFT
29	1	1309606	FLAG UP SW, RIGHT
30	1	1309607	BRACKET,LIMIT SWITCH RT
31	1	1309608	BRACKET,LIMIT SWITCH LF
32	4	1317249	PLATE, NUT
33	1	13911015	SHAFT COLLAR, MOD
34	4	BB51110	THRUST BEARING,50X70X14
35	1	BB51210	BEARING, THRUST,50X78X22
36	1	BBUCP206	BEARING, PILLOWBLOCK
37	1	CC-1-24M1	BEARING BOX, MOD
38	2	CC-1-01	METRIC NUT
39	2	CC-1-02	LEAD SCREW
40	AR	CC-1-05	BEVEL GEAR
41	1	CC-1-06	DRIVE SHAFT,1309
42	AR	CC-1-14	LEAD SCREW MOUNT BLK.
43	AR	CC-1-15A	SIDE PLATE
44	AR	CC-1-16	SHOULDER BOLT, UNBALER
45	AR	CC-1-16A	SHOULDER BOLT, UNBALER

1309 parts list continued

ITEM NO.	HARDWARE SHOWN/QTY.	PART NUMBER	DESCRIPTION
46	8	CC-1-17	ROLLER,SPRING UNBAILER
47	4	CC-1-18	SPACER,SHOULDER BOLT
48	AR	CC-1-19	BOLT, M16 X 210
49	2	CC-1-20-A	FLANGE,140MM OD,52MM ID
50	2	CC-1-20-C	FLANGE BEARING ASSY
51	2	CC-1-22	LEAD SCREW SUPPORT
52	2	CC-1-23	BEARING
53	1	CC-1-24M	BEARING BOX, MOD
54	2	CC-1-25	DRIVE SHAFT BEARING
55	AR	CC-1-28	SUPPORT BEAM
56	AR	CC-1-39	ROLLER MOUNT PLATE
57	4	CC-1-40	EYE BOLT,ROLLER GUIDE
58	4	CC-1-41	EYE BOLT, ROLLER GUIDE
59	AR	CC-1-42A	PLATE,MOTOR MOUNT
60	AR	CC-1-59	COVER, GEAR, 1309
61	AR	CC-1-61	GUARD, TOP
62	8	CCCLM20FT	CLAMP COLLAR- M20
63	1	FF3460	STRAIN RELIEF,LIQ TIGHT, 3/4NPT
64	1	FF8465	NUT,LOCK, 3/4NPT,NYLON,BLK
65	1	MM80	CHAIN,SGL STRD,1"P
66	1	MM80SK16H	SPROCKET,16T,1"P,1.25B
67	1	MM112MP4BRE40	MOTOR,BRAKE,5HP,1750 RPM,
68	2	MM6052T44	CAUTION TAPE
69	54	NNE10-32	NUT,ELASTIC LOCK
70	8	NNEM10-1.5	NUT,ELASTIC LOCK,M10
71	4	NNHM12X1.75	NUT,HEX,M12
72	4	NNJ1/4-20	NUT, HEX, JAM, 1/4-20
73	AR	NNJM8	NUT,JAM,M8,ZINC PLATED
74	AR	NNJM14X1	NUT,JAM,M14X1.0
75	AR	NNK1/4-20	KEP NUT, 1/4-20
76	AR	SSHC01048	1/4-20 X 3/4 HEX CAP
77	AR	SSHC98048	SCREW, HEX CAP #10-32X.75
78	AR	SSPSM4X10	M4-0.70X10
79	8	SSSCM3X30	SCREW,SOC CAP,M3 X 30MM
80	4	SSSCM5X22	SCREW,SOCKET CAP,M5-.9X22
81	7	SSSCM6X10	M6X10 SOC CAP SCREW
82	8	SSSCM6X15	M6X15 SOC CAP SCREW
83	24	SSSCM8X25	SCREW,SOC CAP,M8X25
84	4	SSSCM10X20	CAP SCREW 10MM X 20MM
85	AR	SSSCM10X35	CAP SCREW 10MM X 35MM
86	8	SSSCM10X75	10MM X 75MM CAP SCREW
87	AR	SSSCM12X25	SCREW, M12 X 25
88	8	SSSCM12X35	SCREW, M12 X 35
89	6	SSSCM12X40	SCREW, M12 X 40
90	8	SSSCM12X50	SCREW, M12 X 50

11309 parts list continued

ITEM NO.	HARDWARE SHOWN/QTY.	PART NUMBER	DESCRIPTION
91	4	SSSCM14X40	SCREW, M14 X 40
92	8	SSSCM20X65	SCREW, M20 X 65
93	4	SSSS01016	1/4-20 X 1/4 KNURL PT
94	1	WPWRT10015	GEARBOX
95	AR	WWFM4.3	WASHER, FLAT, M4
96	AR	WWFM6	WASHER, FLAT, M6, SAE
97	AR	WWFM6.1	WASHER, FLAT, M6, SAE
98	AR	WWFM8	WASHER, FLAT, M8 I.D.
99	AR	WWFM10	WASHER, FLAT, M10 I.D.
100	AR	WWFM12	WASHER, FLAT, M12 I.D.
101	AR	WWFM14	FLAT WASHER,M14
102	AR	WWFM20	WASHER, FLAT, M20 I.D.
103	AR	WWFS1/4	WASHER,FLAT,SAE,1/4
104	AR	WWFS10	WASHER, FLAT, #10, SAE
105	4	WWLM5	M5 LOCK WASHER
106	AR	WWLM6	WASHER,LOCK,M6
107	AR	WWLM8	M8 LOCK WASHER
108	AR	WWLM10	M10 LOCK WASHER
109	AR	WWLM12	M12 LOCK WASHER
110	AR	WWLM14	M14 LOCK WASHER
111	8	WWLM20	M8 LOCK WASHER

1309015 Operator Station Assembly

AAC Drawing Number 1309015 Rev0

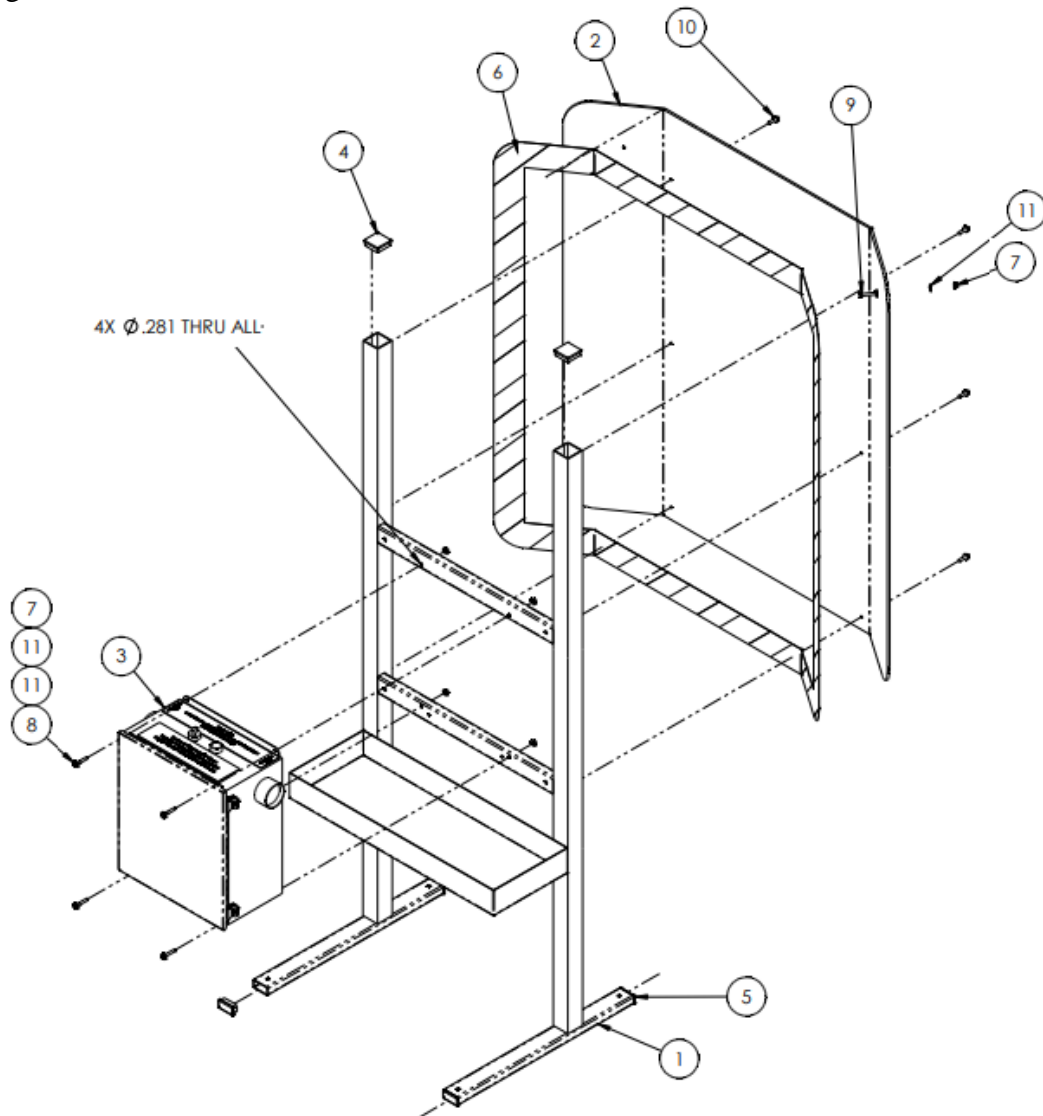

ITEM NO.	QTY.	PART NUMBER	DESCRIPTION
1	1	1309010	FRAME, STAND, 1309
2	1	1309014	GUARD, OPER. STATION
3	1	1309018	CONTROL PANEL
4	2	MM132-2X2A	END CAP, SQUARE, BLACK
5	4	MM132-1496	PLUG 1 X 2
6	1	MM6052T44	CAUTION TAPE
7	5	NNK1/4-20	NUT,KEP,1/4-20
8	4	SSHC01096	1/4-20 X 1-1/2 HHCS
9	1	SSHC01128	1/4-20 X 2 HEX HEAD
10	6	SSZS01080	SCREW,SHT MTL,W/WASHER
11	10	WWFS1/4	WASHER,FLAT,SAE,1/4

⚠ use only Allen Bradley parts here.

REPLACEMENT 120V AC/DC BULB FOR  
OLD UNITS WITH DIODES IS MM800FN130

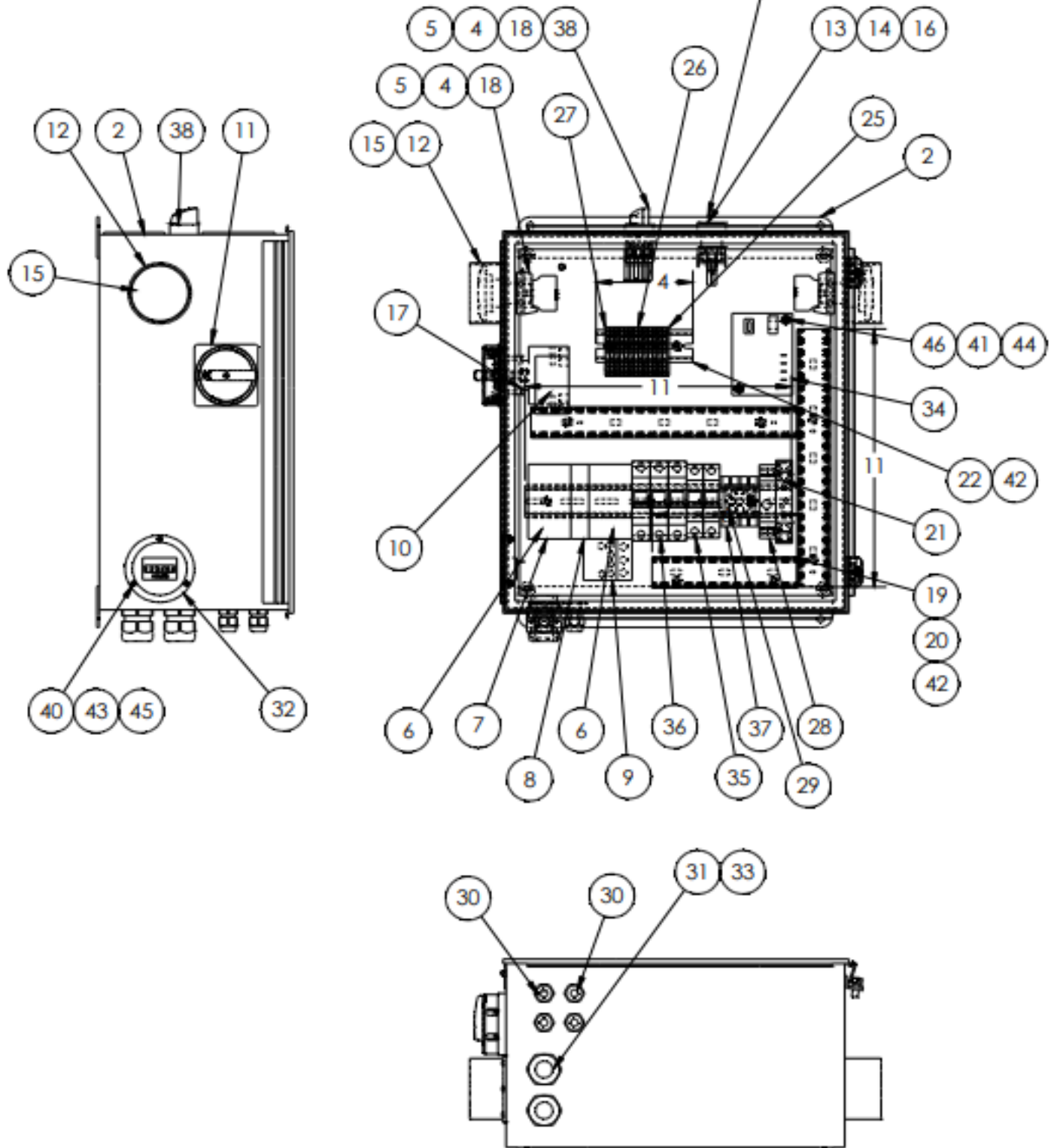

1309018 parts list

ITEM NO.	QTY	PART NUMBER	DESCRIPTION
1	A/R*	1309-WD	WIRING DIAGRAM
2	1	1309017	ENCLOSURE & PLATE, MOD
3	1	1309030	BACK PANEL MODIFICATION
4	5	EE3X01	BLOCK,P.B. CONTACT, N.C. (RED)
5	4	EE3X10	BLOCK,P.B. CONTACT, N.O. (GRN)
6	2	EE100C16L10	CONTACTOR,4P,16A,240V,IEC
7	2	EE100FC31	CONTACTOR AUX BLOCK,100C
8	1	EE100MCA00	CONTACTOR INTERLOCK
9	1	EE193-EA1GB	CONTACTOR OVERLOAD,12-32A
10	1	EE194A32PE	GROUNDING TERMINAL
11	1	EE194LHE6N175	DISCONNECT HANDLE,RED/YEL
12	2	EE800EP-A6PR5	PUSHBUTTON GUARD,22MM,YEL
13	1	EE800EP-P7	PILOT,22MM,CLEAR,240V
14	1	EE800F-N240	NEON LAMP, 240VAC
15	2	EE800FP-MM65	PUSHBUTTON,22MM,MOM,MUSH,
16	1	EE800FPD0C	LAMP HOLDER BLOCK,NO LAMP
17	1	EE194E251753	DISCONNECT,3 POLE,25A,IEC
18	3	EEA3L	LATCH,PUSH BUTTON
19	2.3 FT	EEDC1LG	DUCT,WIRE COVER,1"
20	2.3 FT	EEDF1X2	DUCT,WIRE,1X2
21	1	EEHRN56240	RELAY,3-PHASE MONITOR
22	15"	EETS35X7.5A	DIN RAIL-AMERICAN
23	A/R*	FF209-502	WAGO MARKERS (1-10)
24	A/R*	FF209-503	WAGO MARKERS (11-20)
25	1	FF280-308	TERMBLK ENDPLATE,WAGO,280
26	11	FF280-901	TERMBLK,WAGO,TOP,SNGL,GRY
27	2	FF280-907	TERMBLK,WAGO,TOP,SNGL,GRN
28	1	FF700-FEB3TU23	RELAY,TIMER,SPDI,DIN
29	1	FF700-HA32A2	RELAY,OCTAL,DPDT,10A
30	4	FF3210	STRAIN RELIEF, PG-9, 18-.31, BLK
31	2	FF3234	STRAIN RELIEF,3/4NPT
32	1	FF3311-1000	HOUR METER,LCD,AC/DC
33	2	FF8465	NUT,LOCK, 3/4NPT,NYLON,BLK
34	1	FFECS61BC	RELAY,CURRENT,2-20A
35	1	FFL722C	BREAKER, CIRCT. THERM-MAG
36	1	FFL7253C	CIRCUIT BREAKER,THERM-MAG
37	1	MM700HN125	RELAY BASE DIN RAIL MNT
38	1	MM800EPSM22	SWITCH, 2 POS SELECTOR
39	3	NNH4-40	NUT,HEX,#4-40
40	3	SSBC70024	#4-40 X 3/8 BHCS
41	2	SSPS90064	8-32 X 1 PAN HD
42	11	SSPS98024	10-32X3/8 PAN HD SLOT
43	3	WWF4	WASHER, FLAT, #4
44	2	WWF8	WASHER, FLAT, #8
45	3	WWL4	WASHER,LOCK,#4
46	2	WWL8	WASHER,LOCK,#8



1309-WD1 Wiring Diagram, 220 Volt Input, Panel Wiring  
 AAC Drawing 125781B Rev 5

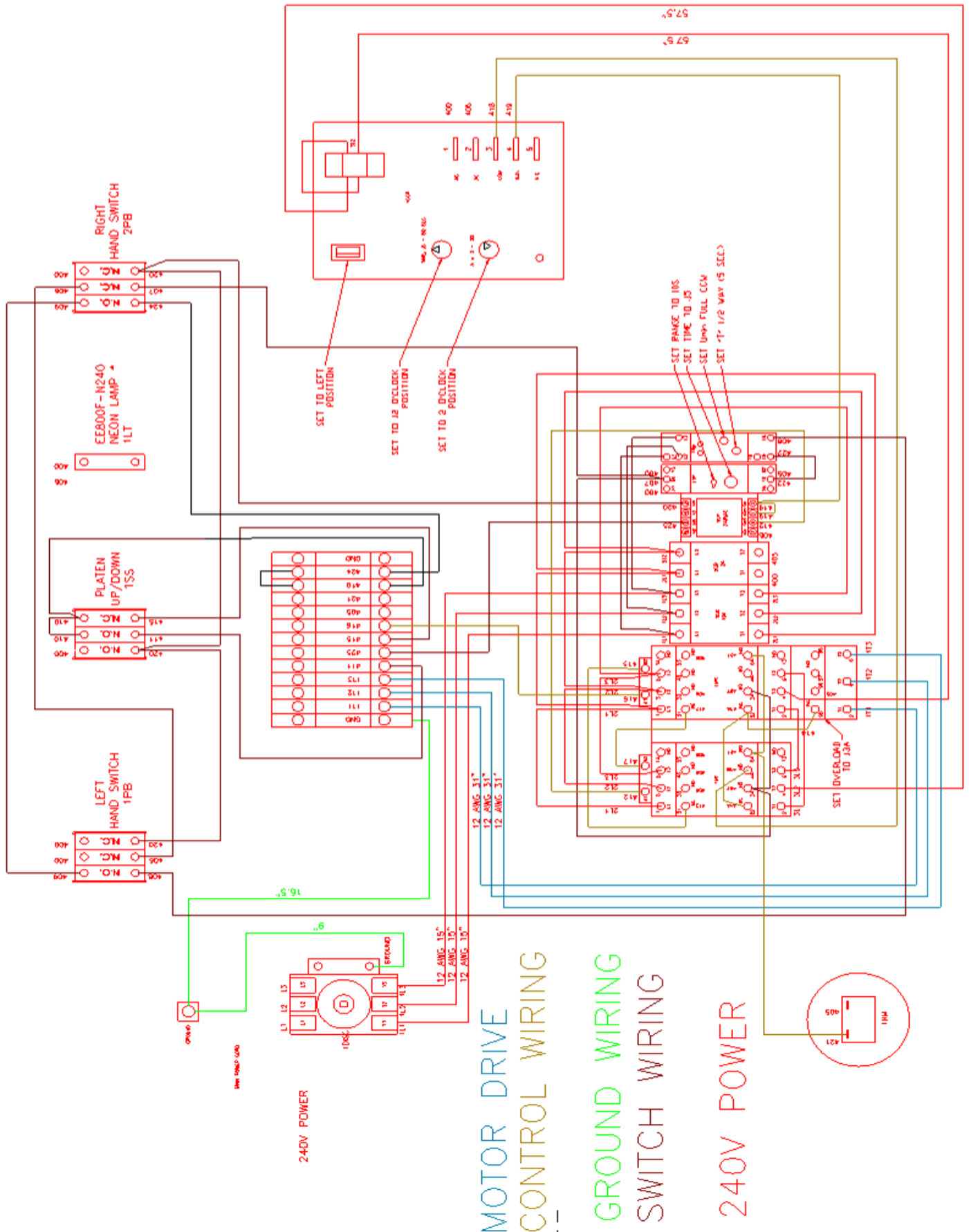

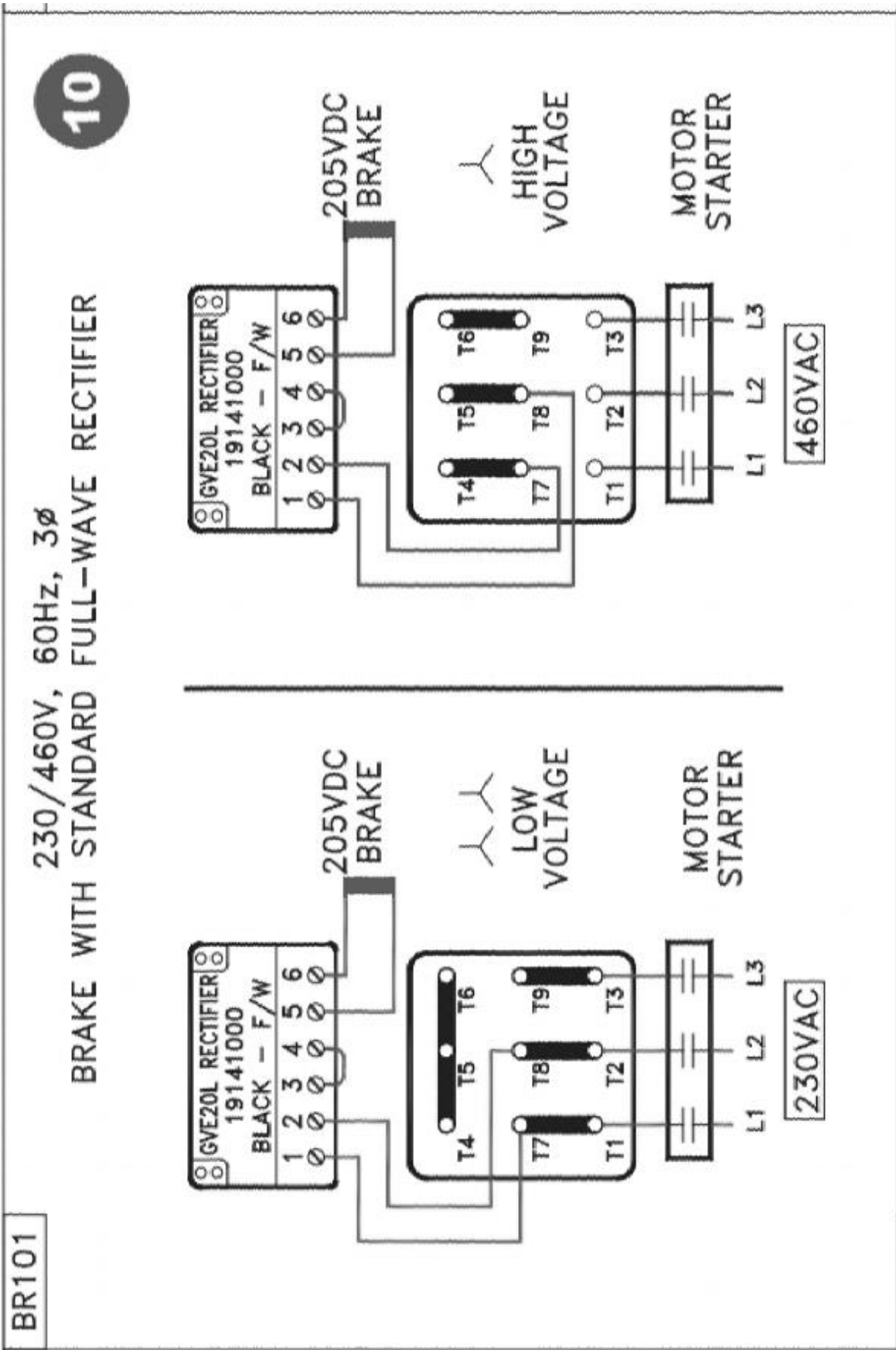

1309-WD2 Wiring Schematic, Unbaler, UL Certified, 220 Volt Input  
AAC Drawing 125426D Rev 2

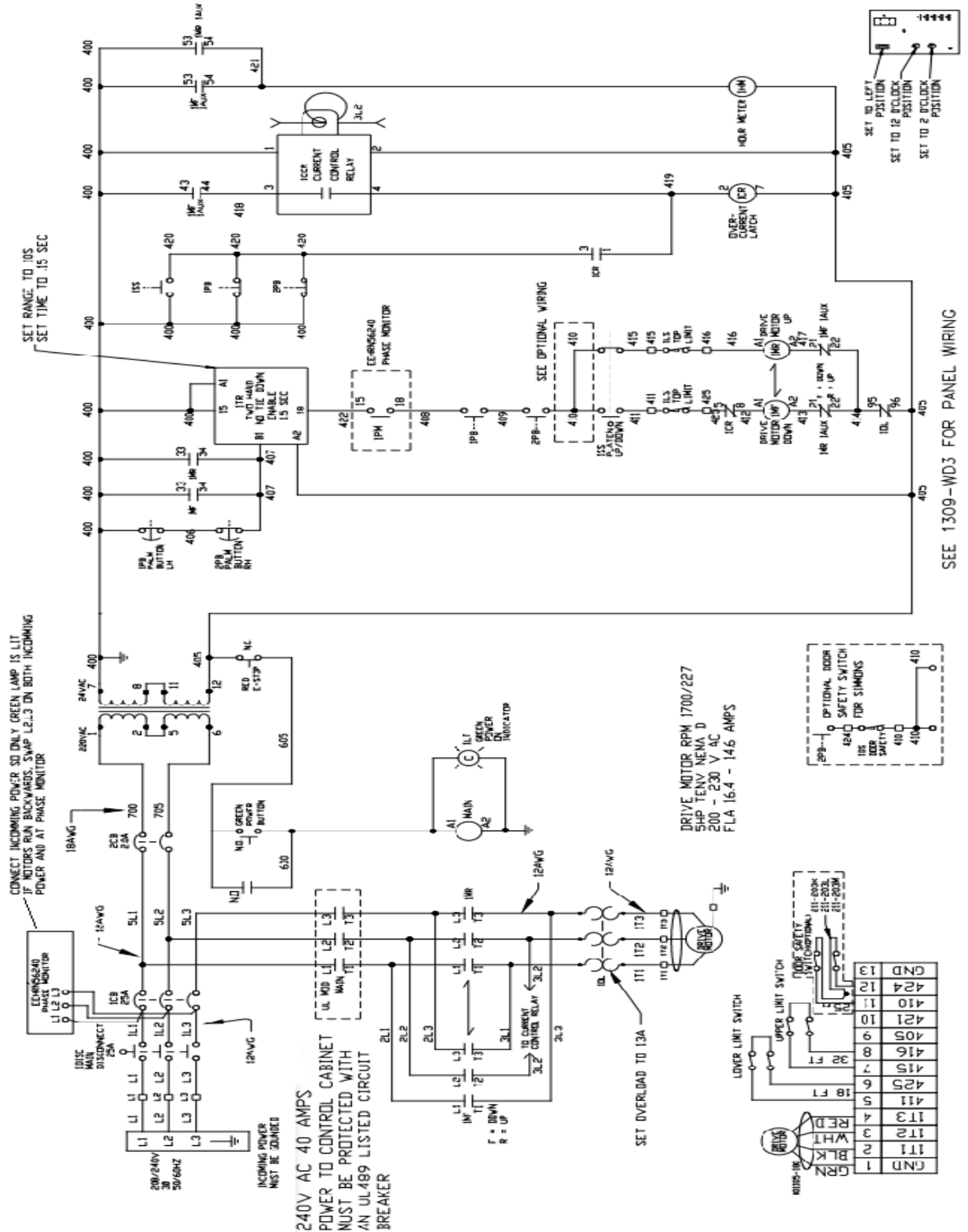

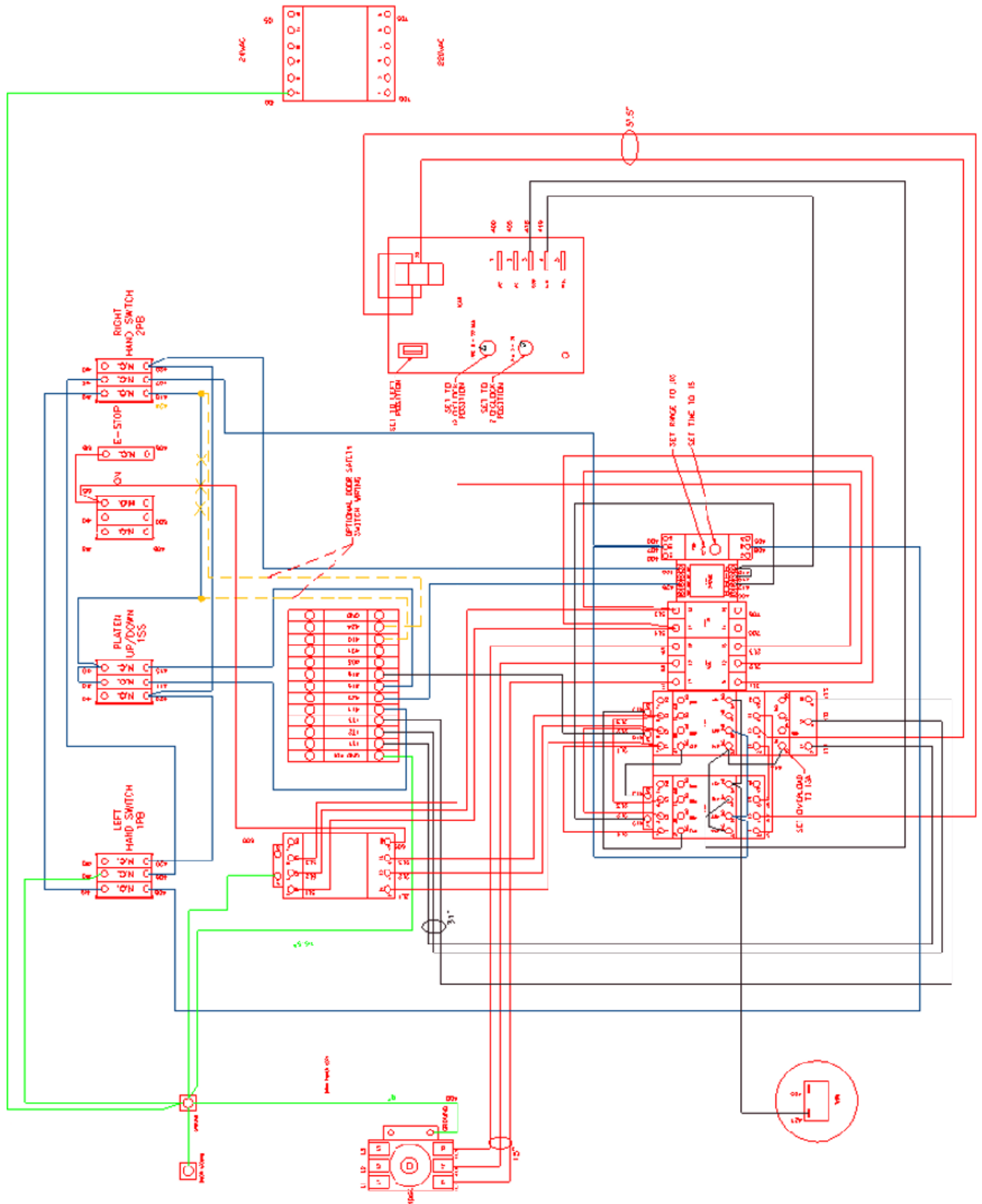

---

# Atlanta Attachment Company (AAC) Statement of Warranty

## Manufactured Products

Atlanta Attachment Company warrants manufactured products to be free from defects in material and workmanship for a period of eight hundred (800) hours of operation or one hundred (100) days whichever comes first. Atlanta Attachment Company warrants all electrical components of the Serial Bus System to be free from defects in material or workmanship for a period of thirty-six (36) months.

## Terms and Conditions:

- AAC Limited Warranty becomes effective on the date of shipment.
- AAC Warranty claims may be made by telephone, letter, fax, or e-mail. All verbal claims must be confirmed in writing.
- AAC reserves the right to require the return of all claimed defective parts with a completed warranty claim form.
- AAC will, at its option, repair or replace the defective machine and parts upon return to AAC.
- AAC reserves the right to make the final decision on all warranty coverage questions.
- AAC warranty periods as stated are for eight hundred (800) hours or one hundred (100) days whichever comes first.
- AAC guarantees satisfactory operation of the machines based on generally accepted industry standards, contingent upon proper application, installation, and maintenance.
- AAC Limited Warranty may not be changed or modified and is not subject to any other warranty expressed or implied by any other agent, dealer, or distributor unless approved in writing by AAC in advance of any claim being filed.

## What Is Covered

- Electrical components that are not included within the Serial Bus System that fail due to defects in material or workmanship, which are manufactured by AAC are covered for a period of eight hundred (800) hours.
- Mechanical parts or components that fail due to defects in material or workmanship, which are manufactured by AAC.
- Purchased items (sewing heads, motors, etc.) will be covered by the manufacturers (OEM) warranty.
- AAC will assist in the procurement and handling of the manufacturers (OEM) claim.

## What Is Not Covered

- Parts that fail due to improper usage, lack of proper maintenance, lubrication and/or modification.
- Damages caused by; improper freight handling, accidents, fire, and issues resulting from unauthorized service and/or personnel, improper electrical, plumbing connections.
- Normal wear of machine and parts such as Conveyor belts, "O" rings, gauge parts, cutters, needles, etc.
- Machine adjustments related to sewing applications and/or general machine operation.
- Charges for field service.
- Loss of time, potential revenue, and/or profits.
- Personal injury and/or property damage resulting from the operation of this equipment.



## Declaración de Garantía

### Productos Manufacturados

Atlanta Attachment Company garantiza que los productos de fabricación son libres de defectos de material y de mano de obra durante un periodo de ochocientos (800) horas de operación o cien (100) días cual llegue primero. Atlanta Attachment Company garantiza que todos los componentes del Serial bus son libres de defectos de material y de mano de obra durante un periodo de treinta y seis (36) meses.

### Términos y Condiciones:

- La Garantía Limitada de AAC entra en efecto el día de transporte.
- Reclamos de la Garantía de AAC pueden ser realizados por teléfono, carta, fax o correo electrónico. Todo reclamo verbal tiene que ser confirmado vía escrito.
- AAC reserva el derecho para exigir el retorno de cada pieza defectuosa con un formulario de reclamo de garantía.
- AAC va, según su criterio, reparar o reemplazar las máquinas o piezas defectuosas devueltas para AAC.
- AAC reserva el derecho para tomar la decisión final sobre toda cuestión de garantía.
- Las garantías de AAC tiene una validez de ochocientas (800) horas o cien (100) días cual llega primero.
- AAC garantiza la operación satisfactoria de sus máquinas en base de las normas aceptadas de la industria siempre y cuando se instale use y mantenga de forma apropiada.
- La garantía de AAC no puede ser cambiado o modificado y no está sujeto a cualquier otra garantía implicada por otro agente o distribuidor al menos que sea autorizado por AAC antes de cualquier reclamo.

### Lo Que Está Garantizado

- Componentes eléctricos que no están incluidos dentro del sistema Serial Bus que fallen por defectos de materiales o de fabricación que han sido manufacturados por AAC son garantizados por un período de ochocientas (800) horas.
- Componentes mecánicos que fallen por defectos de materiales o de fabricación que han sido manufacturados por AAC son garantizados por un periodo de ochocientas (800) horas.
- Componentes comprados (Motores, Cabezales) son protegidos debajo de la garantía del fabricante.
- AAC asistirá con el manejo de todo reclamo de garantía bajo la garantía del fabricante.

### Lo Que No Está Garantizado

- Falla de repuestos al raíz de uso incorrecto, falta de mantenimiento, lubricación o modificación.
- Daños ocurridos a raíz de mal transporte, accidentes, incendios o cualquier daño como resultado de servicio por personas no autorizados o instalaciones incorrectas de conexiones eléctricas o neumáticas.
- Desgaste normal de piezas como correas, anillos de goma, cuchillas, agujas, etc.
- Ajustes de la máquina en relación a las aplicaciones de costura y/o la operación en general de la máquina.
- Gastos de Reparaciones fuera de las instalaciones de AAC
- Pérdida de tiempo, ingresos potenciales, y/o ganancias.
- Daños personales y/o daños a la propiedad como resultado de la operación de este equipo.