



TYPICAL

TW1-1245-D2

**SINGLE NEEDLE COMPOUND FEED
LOCKSTITCH SEWING MACHINE WITH
THREAD TRIMMER**

OPERATION INSTRUCTION / PARTS MANUAL

Operation Instruction

Contents

OPERATION INSTRUCTION

1. Brief introduction	1
2. Main specifications	1
3. Feed adjustment/reverse stitching	1
4. Adjusting the upper feed stroke	1
5. Winding bobbin thread	2
6. Adjusting the bobbin thread tension	2
7. Threading needle thread/adjusting the tension of needle thread	2
8. Maintenance	3
9. Oiling	3
10. Lubricating the hook	4
11. Lubricating the machine head	4
12. Lubricating the upper feed driving eccentric	4
13. Adjusting the feed dog	5
14. Pre-adjusting the needle height	6
15. Centering the needle in the needle hole	6
16. Adjusting the feed dog position	6
17. Lower feed adjustment	7
18. Position of needle and rotary hook	7
19. Adjusting the lifting amount of presser feet	7
20. Top feed adjustment	8
21. Adjusting the bobbin case opener	8
22. Safety clutch	8
23. Needle thread tension release	9
24. Bobbin thread winder	9
25. Adjusting the height of movable knife	9
26. Adjusting the position of fixed knife	10
27. The position of thread holding spring plate	10

PARTS MANUAL

1. Machine casting components	11-12
2. Needle and presser foot components	13-16
3. Presser foot lifting components	17-18
4. Thread take-up and thread tension components	19-20
5. Feed adjusting components	21-22
6. Upper shaft and rocking shaft components	23-24
7. Timing belt components	25-26
8. Hook saddle components	27-28
9. Needle plate and hook components	29-30
10. Lower feed components	31-32
11. Lower shaft components	33-34
12. Auto-reverse stitching components	35-36
13. Automatic thread trimmer components	37-38
14. Tension release components	39-40
15. Accessories	41-44

1. Brief introduction

Machine adopts compound feed and the max. lifting amount of presser feet reaches 7mm, which guarantees the high sewing quality of different materials. Besides, it adopts the large self-lubrication hook, 4-link thread take-up and timing belt driven mechanism, which assures its lower noise even at high speed. This machine is widely used in manufacturing suitcase, sofa, car seat, upholstery, etc.

2. Main specification

Application	Medium and heavy duty
Max. sewing speed	2000 s.p.m
Max. stitch length	8mm
Needle bar stroke	36mm
Needle	DPx35 (Nm80-Nm140)
Lubrication	Semi-lubrication
Motor	AC Servo motor

3. Feed adjustment/reverse stitching (Fig. 1)

1. To adjust the stitch length by turn the dial 1. And lift the bar to start the reverse stitching.

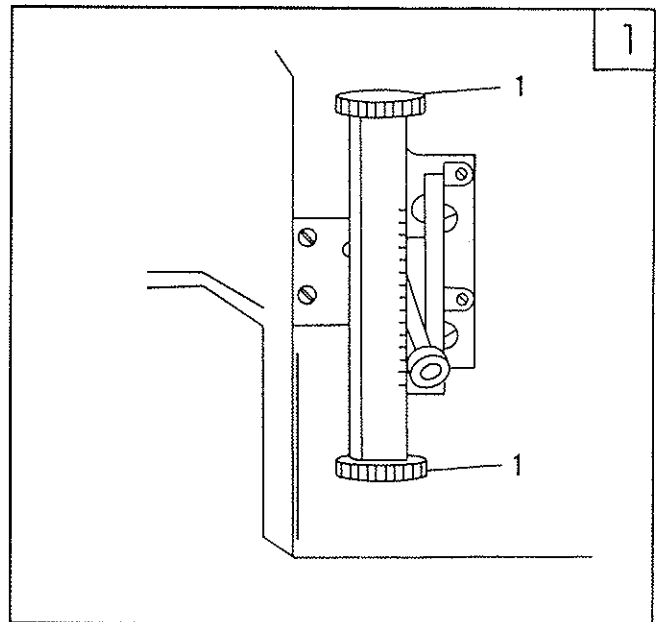

4. Adjusting the upper feed stroke(Fig. 2)

Open the rear cover 1, loosen the screw 2, and upon required, move it up or down.

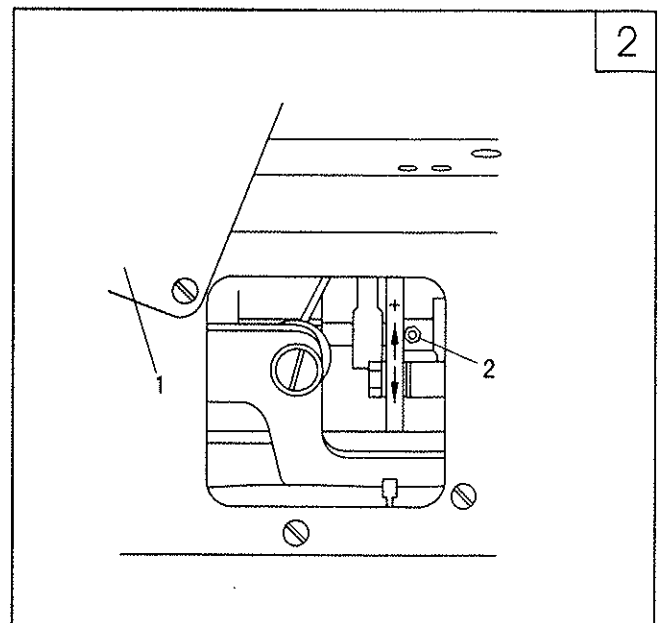

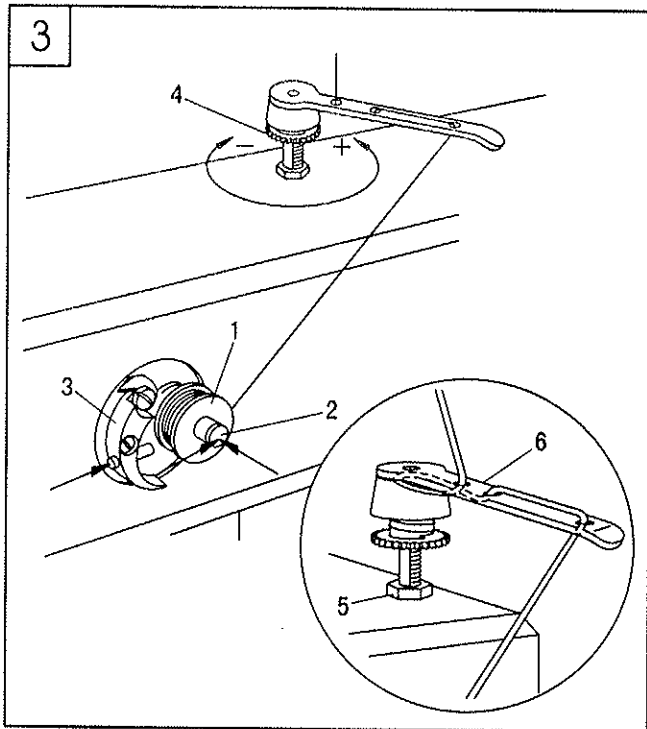

5. Winding bobbin thread (Fig. 3)

1. Put the bobbin into the bobbin shaft 2;
 2. As shown by Fig. 3, draw out the thread and winding several circles clockwise on the bobbin;
 3. Press down the shaft 2 and the gib 3 to start the winding;
 4. Adjust the tension of bobbin 1 by turning the screw 4;
 5. When the bobbin winding is full, the winding operation will stop automatically;
- If the winding is abnormal, loosen the nut 5, and as required, move the thread guide 6, then tighten the nut 5.

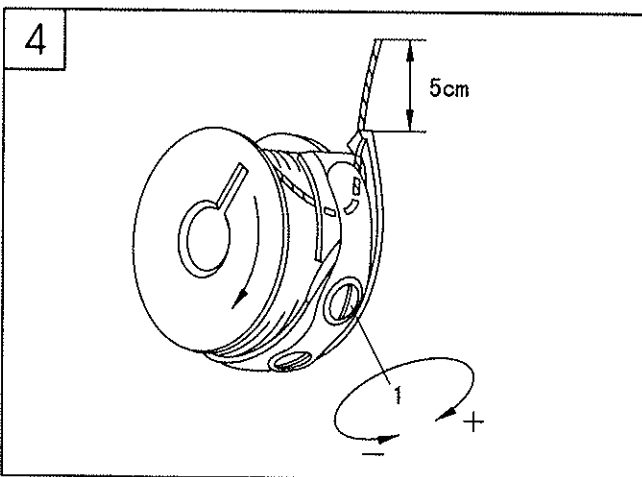

6. Adjusting the bobbin thread tension (Fig. 4)

1. Draw out the bobbin thread shown by Fig. 4. When the bobbin thread is drawn out, the bobbin should turn as the arrow goes.
2. Adjusting the tension of bobbin thread by turning the screw 1.

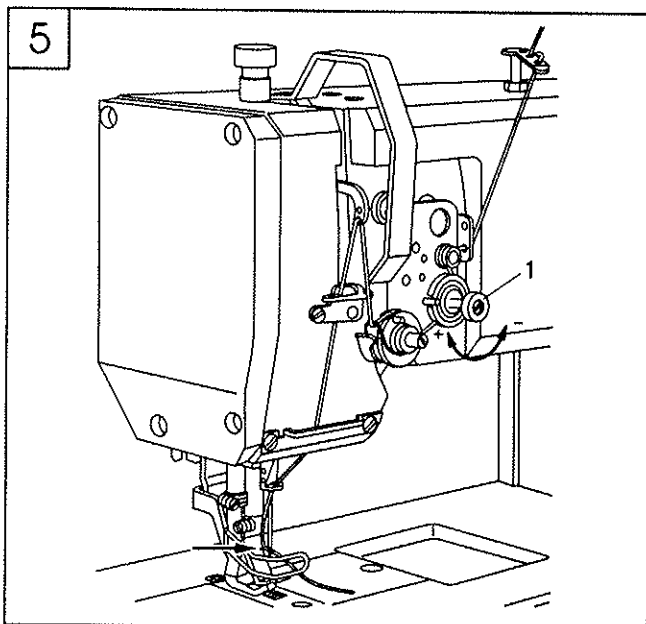

7. Threading needle thread/adjusting the tension of needle thread (Fig. 5)

1. Threading as the Fig. 5 shows; Pass the thread through the needle eye from the left side
2. Adjusting the tension of needle thread by turning the screw 1.

8. Maintenance(Fig. 6)

Clean hook aperture	Every day
Normal oiling	Twice a week
Machine head oiling	Twice a week
Check oil box for hook	Once a week
Clean hook	Once a week
Oiling the upper feed driven eccentric	Once a year

※ The above data is due to the normal situation, if the machine is used frequently, the interval of the maintenance should be shortened.

Maintenance for rotary hook (Fig. 6)

1. Clean the hook aperture with brush every day;
2. Clean the rotary hook thoroughly every week as follows:
 - a. Open the slide plate and lift the needle bar to it's highest point;
 - b. Take out the bobbin cap and bobbin;
 - c. Release the gib 1, turn the hand wheel until the Point 2 passes to the Groove 3 more than 5mm, then take out the inner hook 4;
 - d. Clean the hook track with paraffin wax;
 - e. When install the inner hook, make sure that the horn 5 must be touched with the groove under the needle plate;
 - f. Tighten the gib 1, put the bobbin and bobbin cap and close the slide plate.

9. oiling (Fig. 7)

Oiling the machine twice a week at the position showed by the arrows.

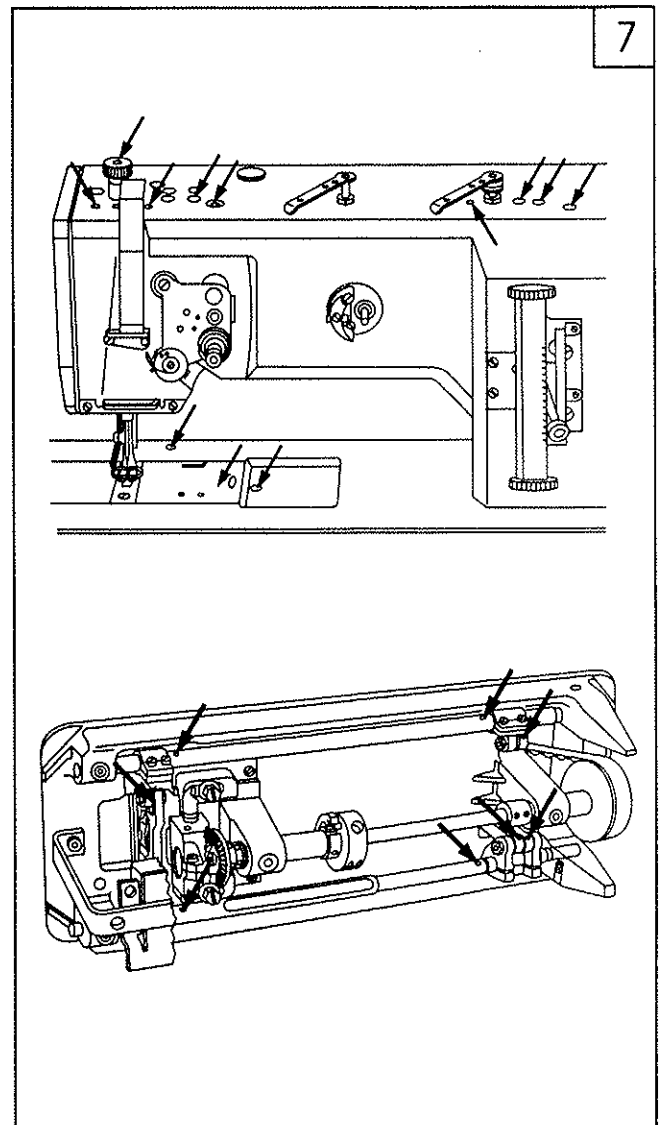
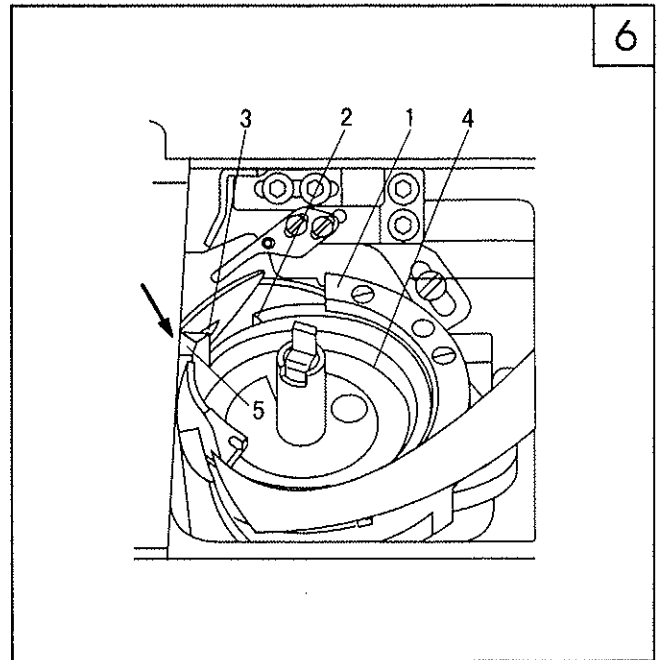

8

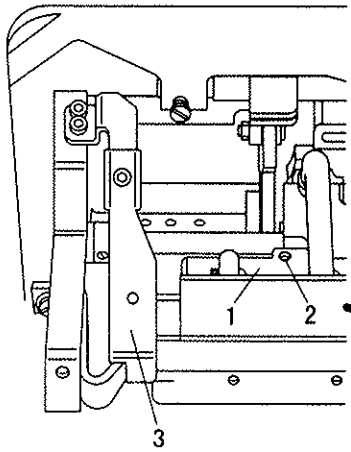

10. Lubricating the hook (Fig. 8)

1. Pull out the knee lever, then lay down the machine head;
2. Fill the oil into box 1 through the hole 2 until the oil level exceeds the highest level mark;
3. Raise the machine head.

9

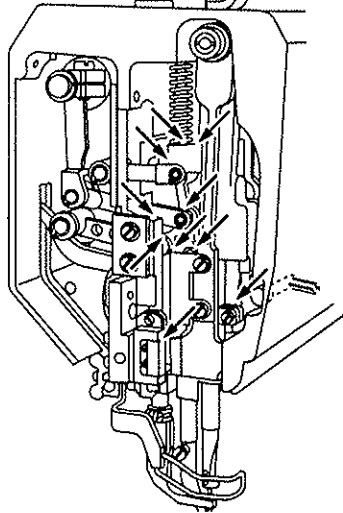

11. Lubricating the machine head (Fig. 9)

1. Open the face plate;
2. Oil at all moving position twice a week as illustrated;
3. Close the face plate.

10

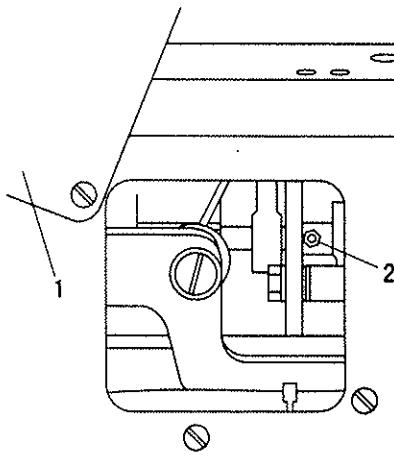

12. Lubricating the upper feed driving eccentric (Fig. 10)

1. Open the back cover 1;
2. Supply the grease on the interface 2 at least once a year.
3. Close the back cover 1.

13. Adjusting the feed dog

1. Positioning the feed dog across the direction of sewing (Fig. 11)

- a. Loosen the screw 1 and 2;
- b. Adjust the shaft 3 as required;
- c. Tighten the screw 1. (keep the screw 2 loosening for the following adjustment)

※ The feed dog must be the same distance from the left and right side of the needle plate cutout.

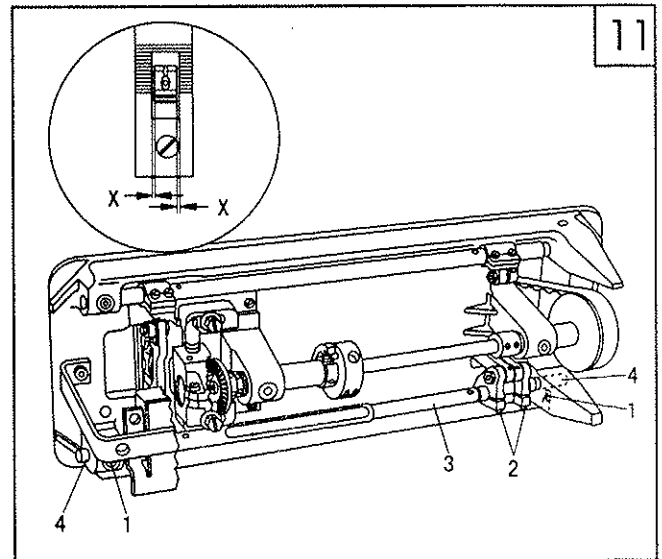

2. Positioning the feed dog in the direction of sewing (Fig. 12)

- a. Set the stitch length max.
- b. Adjust the shaft 1 as required, then tighten the screw 2.

※ With the longest stitch length setting, the clearance between the front and back cutout of needle plate should be same wherever forward or backward stitching.

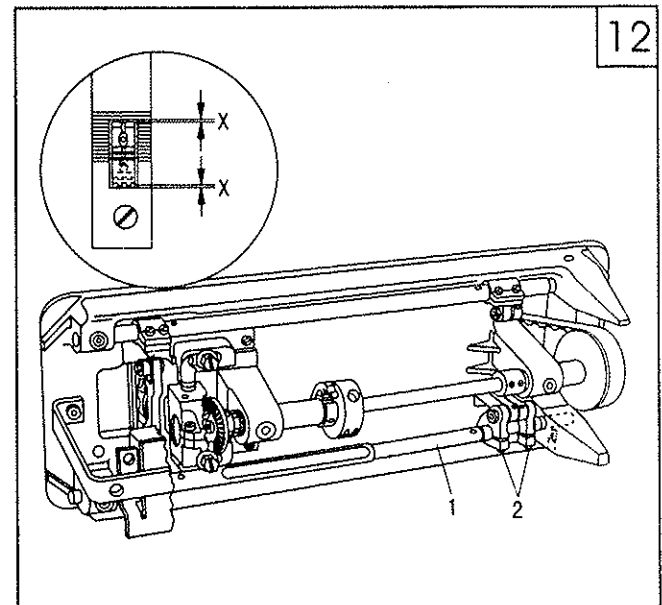

3. Adjust the height of feed dog (Fig. 13)

- a. Set the stitch length zero;
- b. Turn the hand wheel until the feed dog reaches its highest position;

Adjust the feed dog carrier 1 and screw 2 as required.

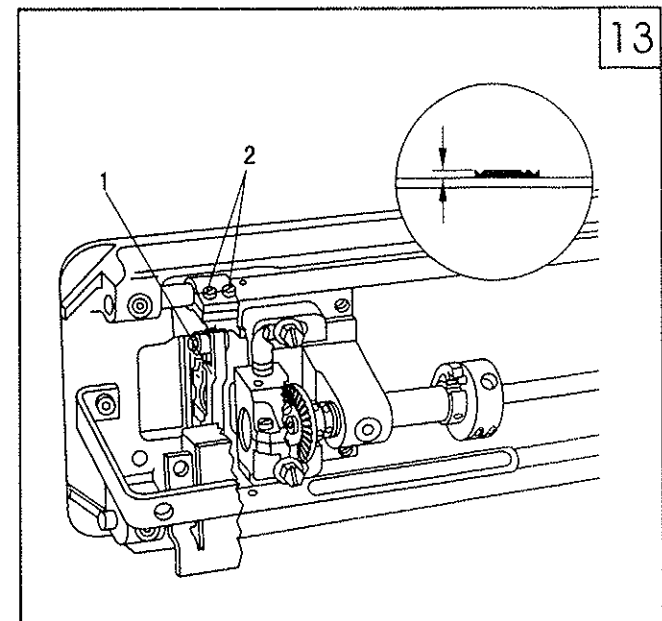

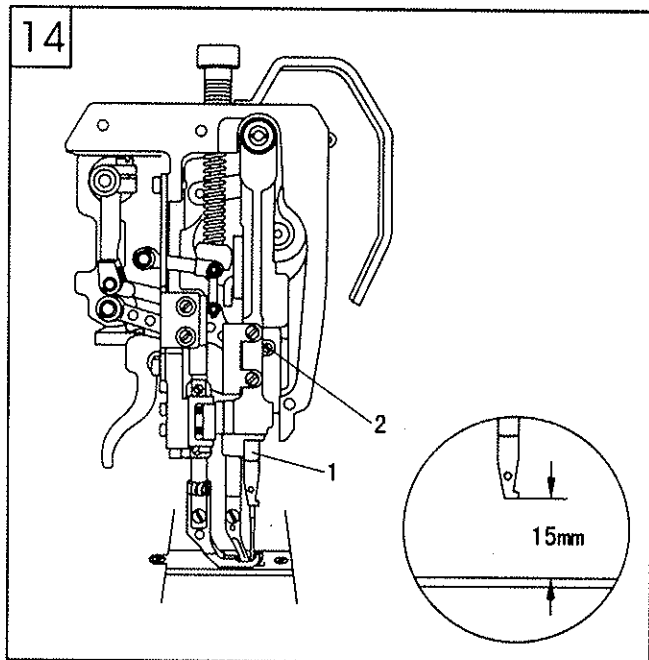

14. Pre-adjust the needle height (Fig. 14)

Move the needle bar 1 (screw 2) up and down and as required, adjust it to the right position.
 ※ When the needle bar is at the lowest position, the clearance between needle bar and needle plate should be 15mm.

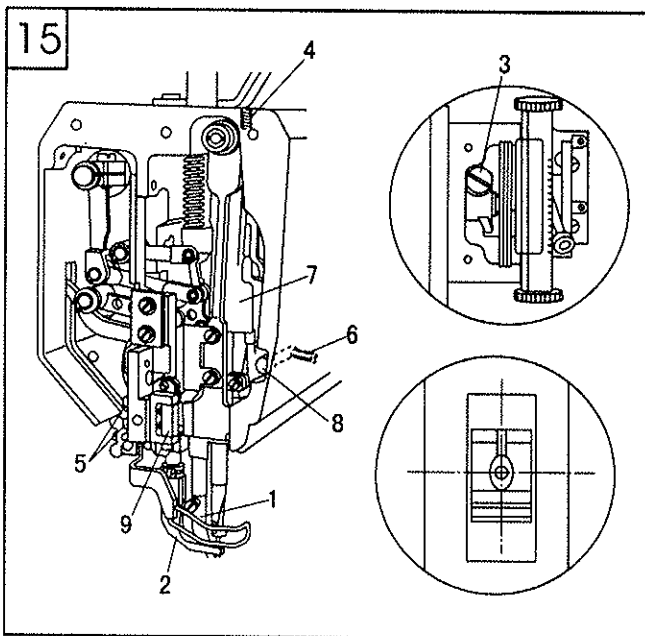

15. Centering the needle in the needle hole (Fig. 15)

1. Loosen the walking foot 1 and presser foot 2.
2. Set the stitch length zero, and lift the needle bar to its highest position;
3. Insert a new needle, and loosen the screw 3,4,5,6;
4. Turn the hand wheel, and pass the needle directly through the feed dog;
5. As required, move the needle bar rocking frame 7;
6. Tighten the screw 3,4,5.
7. Move the pin 8 to make it be touched with the needle bar frame 7, then tighten the screw 6.

※ When set the stitch length zero, the needle must enter the needle hole exactly in the middle.

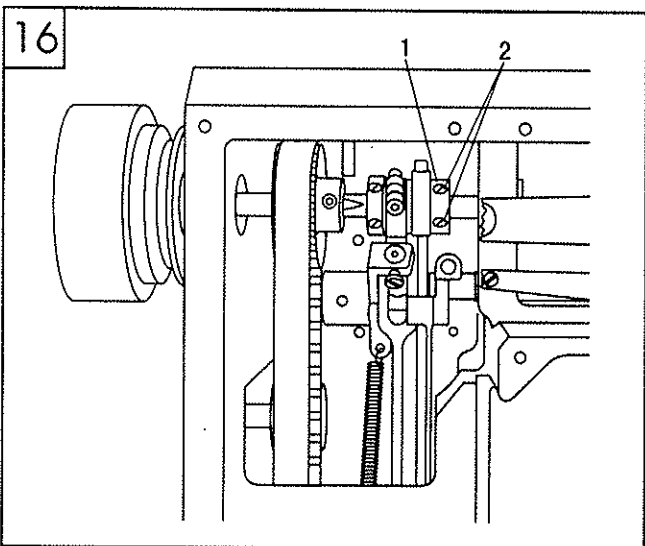

16. Adjusting the feed dog position (Fig. 16)

1. Adjust the needle bar to its lowest position;
2. Turn the eccentric cam 1 (screw 2), and adjust the feed dog to its highest position;
3. Tighten the screw 2 to make the eccentric cam not move;
4. Set the stitch length max. and as required, slightly turn the eccentric cam 1;
5. Tighten the screw 2.

※ a. When the needle bar is at its lowest position, the feed dog should be at its highest position;
 b. Set the stitch length max., turn the hand wheel, while the feed dog and the needle plate are at same level, the needle tip should just reaches the needle plate.

17. Presser foot lifter (Fig. 17)

1. Set the stitch length max.
 2. Loosen the screw 1 to make the feed eccentric cam 2 turn around the shaft;
 3. Lower the needle bar to its lowest position;
 4. Turn the eccentric cam 2 to make the eccentricity face downwards;
 5. As required, turn the eccentric cam a bit as it turns, then tighten the screw 1;
 6. Check again.
- ※ When the stitch length is set to max and the needle bar is at its lowest position, if the reverse feed bar is activated, there will be no feeding.

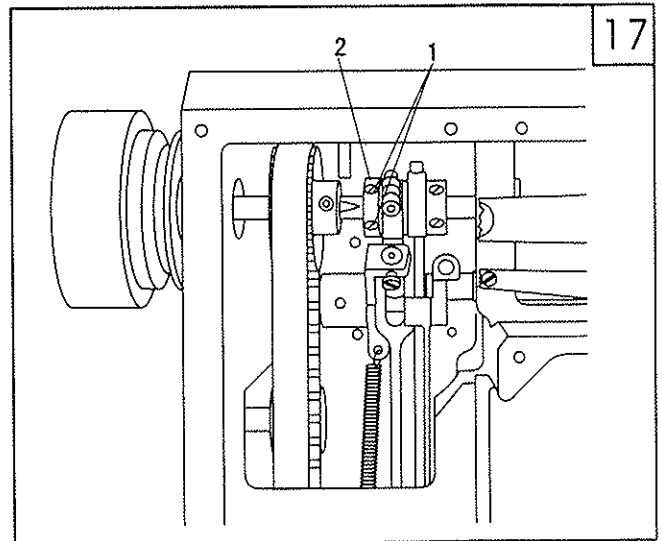

18. Position of needle and rotary hook (Fig. 18)

1. Set the stitch length to "3", and loosen the screw 1 and 2;
 2. The clearance between needle and the hook point should be adjusted to 0.05-0.1mm by moving the hook gear 4;
 3. Tighten the screw 1;
 4. Lower the needle to its lowest position, and continue to turn the hand wheel to raise 2mm from the needle's lowest position;
 5. To make the hook point aim at the center of needle, and be sure that the needle guard 7 doesn't press on the needle;
 6. Leave some gear clearance and tighten screw 2;
 7. To adjust the height of needle bar to make the vertical clearance between the top of needle eye and the hook point should be 0.8-1mm;
 8. The needle guard 7 should touch the needle lightly.
- ※ When the stitch length is set to "3", and the needle is lifted 2mm from its lowest position, the following requirements must be reached:
- a. The clearance between needle and hook point is 0.05-0.1mm;
 - b. The vertical clearance between the top of needle eye and hook point is 0.8-1mm;
 - c. The needle guard must touch the needle lightly.

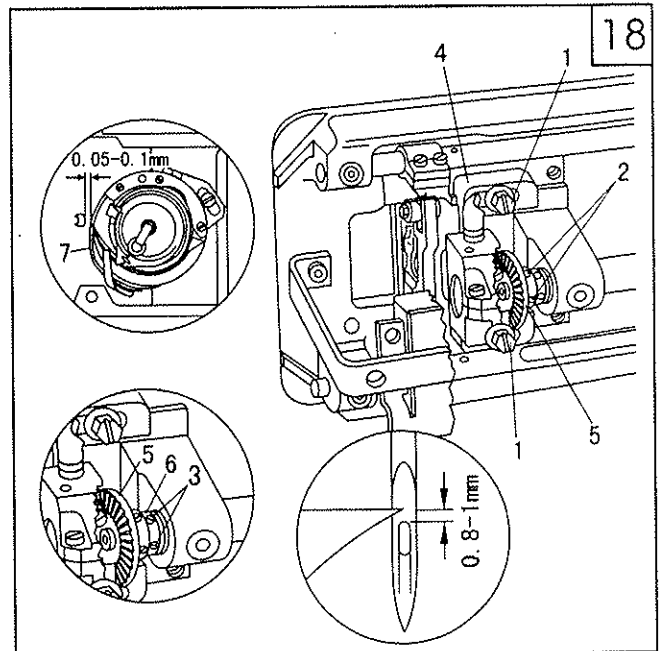

19. Adjusting the lifting amount of presser feet (Fig. 19)

1. Set the stitch length to "zero" and the lifting amount of presser feet to max.;
 2. Lower the presser foot 1 on the needle plate;
 3. Turn the handwheel to lift the walking foot to its highest position;
 4. As required, move the crank 3 (screw 4);
 5. Check again.
- ※ When the stitch length is set to zero and the lifting amount of presser feet is at the max., turn the handwheel to make sure that both of the clearance between presser foot 1/walking foot 2 and needle plate are 7mm.

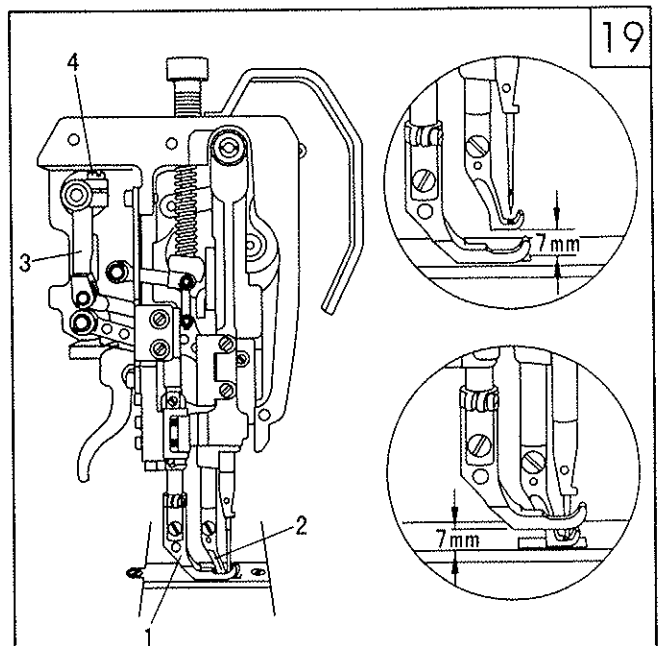

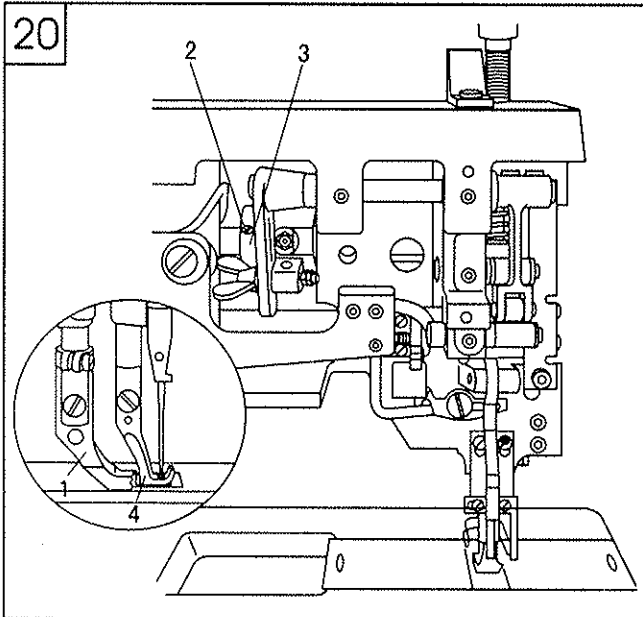

20. Top feed adjustment (Fig. 20)

1. Lower the presser foot on the needle plate;
2. Loosen the screw 2 until the feed lifting eccentric cam 3 can be turned reluctantly;
3. Adjust the eccentric cam 3 as required;
4. Tighten the screw 2;
5. Check again.

※ When the stitch length is set to max and the presser foot is lowered on the needle plate, the walking foot and the needle should reach the needle plate at the same time

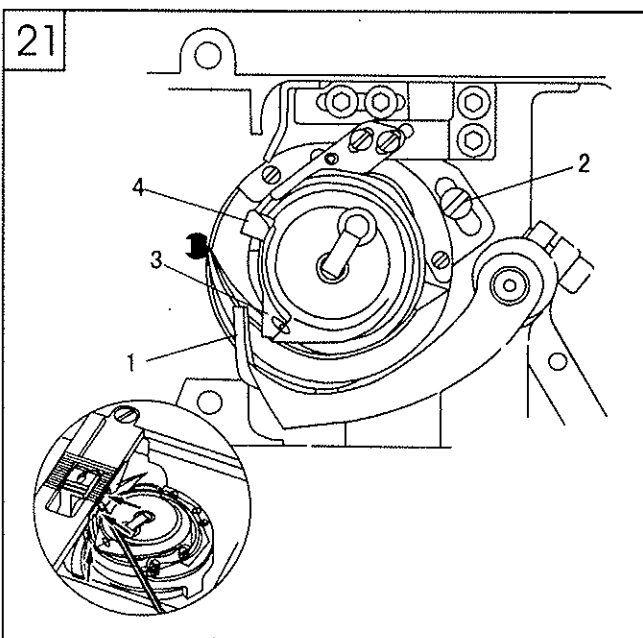

21. Adjusting the bobbin case opener (Fig. 21)

1. Threading the bobbin and needle thread, prepare the materials to be sewn and lower the presser foot;
 2. Turn the hand wheel and sew several stitches, then check as required;
 3. Move the opener 1 (screw 2) as required.
- ※ The needle thread must not be clamped when passing through the mark 1,2,3.

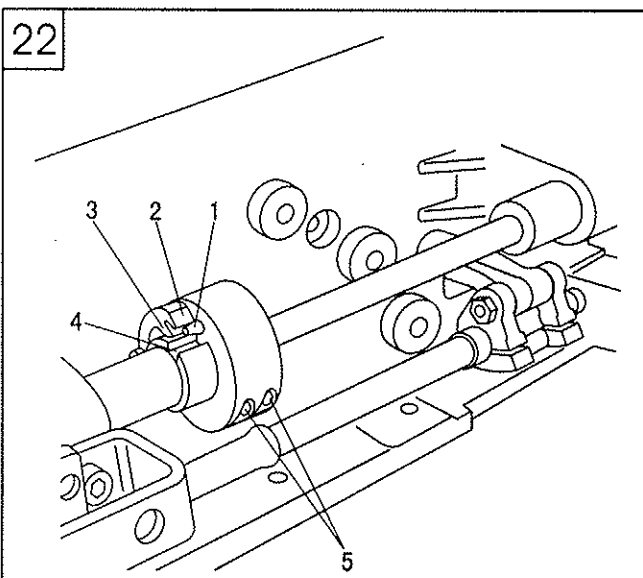

22. Safety clutch (Fig. 22)

1. When the thread is jammed, the safety clutch will be disengaged to prevent the hook from being damaged;
2. Take out the jammed thread;
3. Press the piston 1 and turn the hand wheel until the hook 3 of pawl 2 clicks into groove 4.

23. Needle thread tension release (Fig. 23)

When the presser foot is lifted, the clearance between the two tension discs should be 0.5mm (0.5mm is the min. clearance, if applied to the thick thread, it should be adjusted to 1mm or more).
Adjust the plate 1 as required.

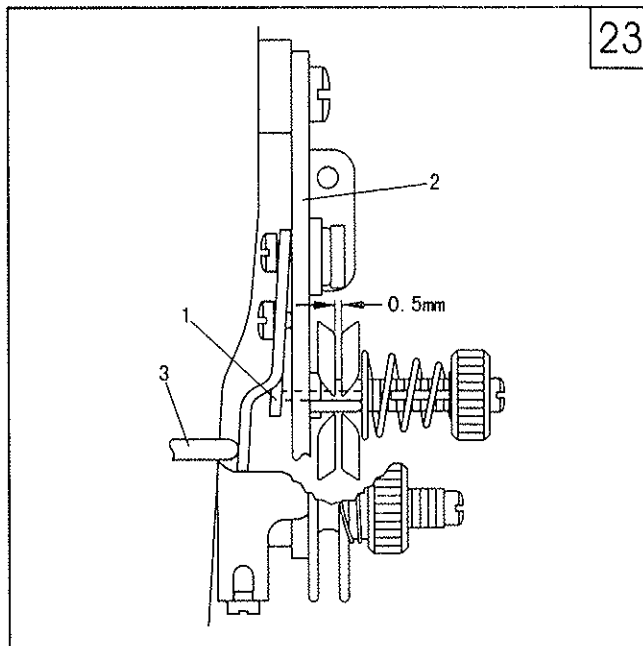

24. Bobbin thread winder (Fig. 24)

1. If the winder is on, it must work reliable, if the winder is off, the friction wheel 5 and the driving gear 1 should get apart;
2. When the thread level is about 1mm from the edge of the bobbin, the winding operation will stop automatically;
3. When winding, insert a bobbin on the winder shaft, threading and switch the winder on. Adjust the pin 3 and screw 4 as required if need.

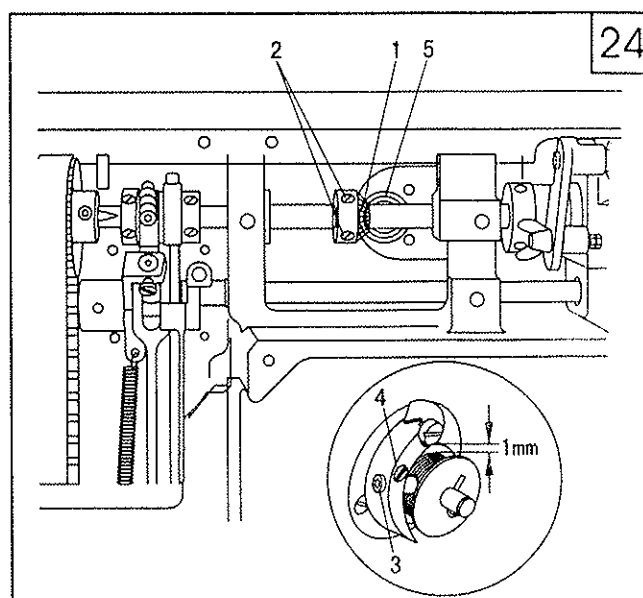

25. Adjusting the height of movable knife (Fig. 25)

When the thread take-up lever is at its highest position, and the movable knife moves forward, the lowest point of movable knife should be higher 0.1mm than the hook surface.

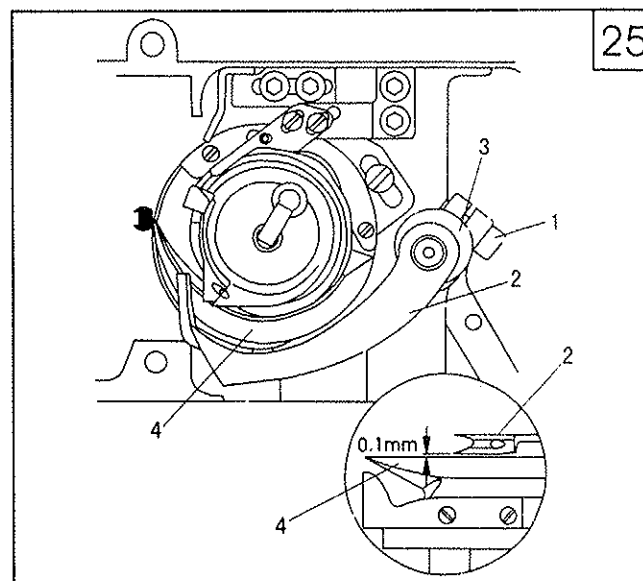

26

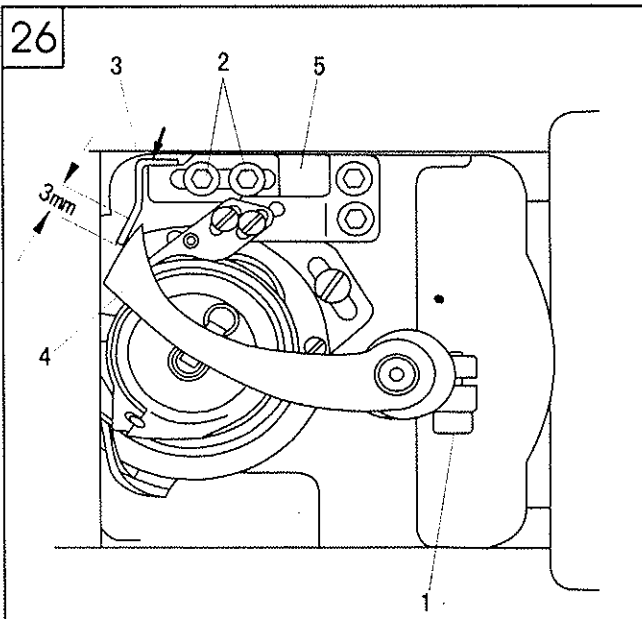

26. Adjusting the position of fixed knife (Fig. 26)

1. The groove of fixed knife 3 must be parallel with knife carrier 5, and cannot touch the machine casting shown by the arrow;
2. When the point of movable knife surpasses the fixed knife 3mm, the fixed knife 3 must touch the movable knife 4.

27

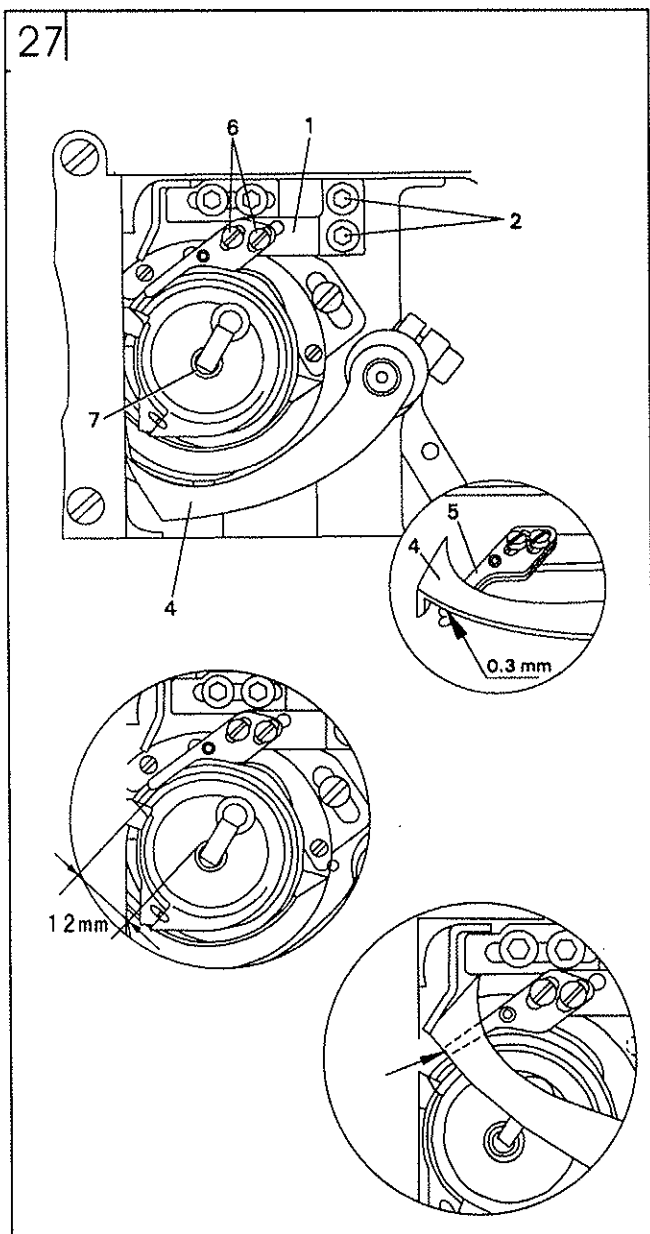

27. The position of thread holding spring plate (Fig. 27)

1. The clearance between movable knife 4 and thread holding spring plate 5 should guarantee 0.3mm;
2. When the movable knife 4 starts to move backward, the front point of plate 5 must be at the same line with the back of movable knife. (shown by arrow);
3. The clearance between the inner edge of spring plate 5 and the bush 7 is 12mm.

Parts Manual

1. Machine casting components

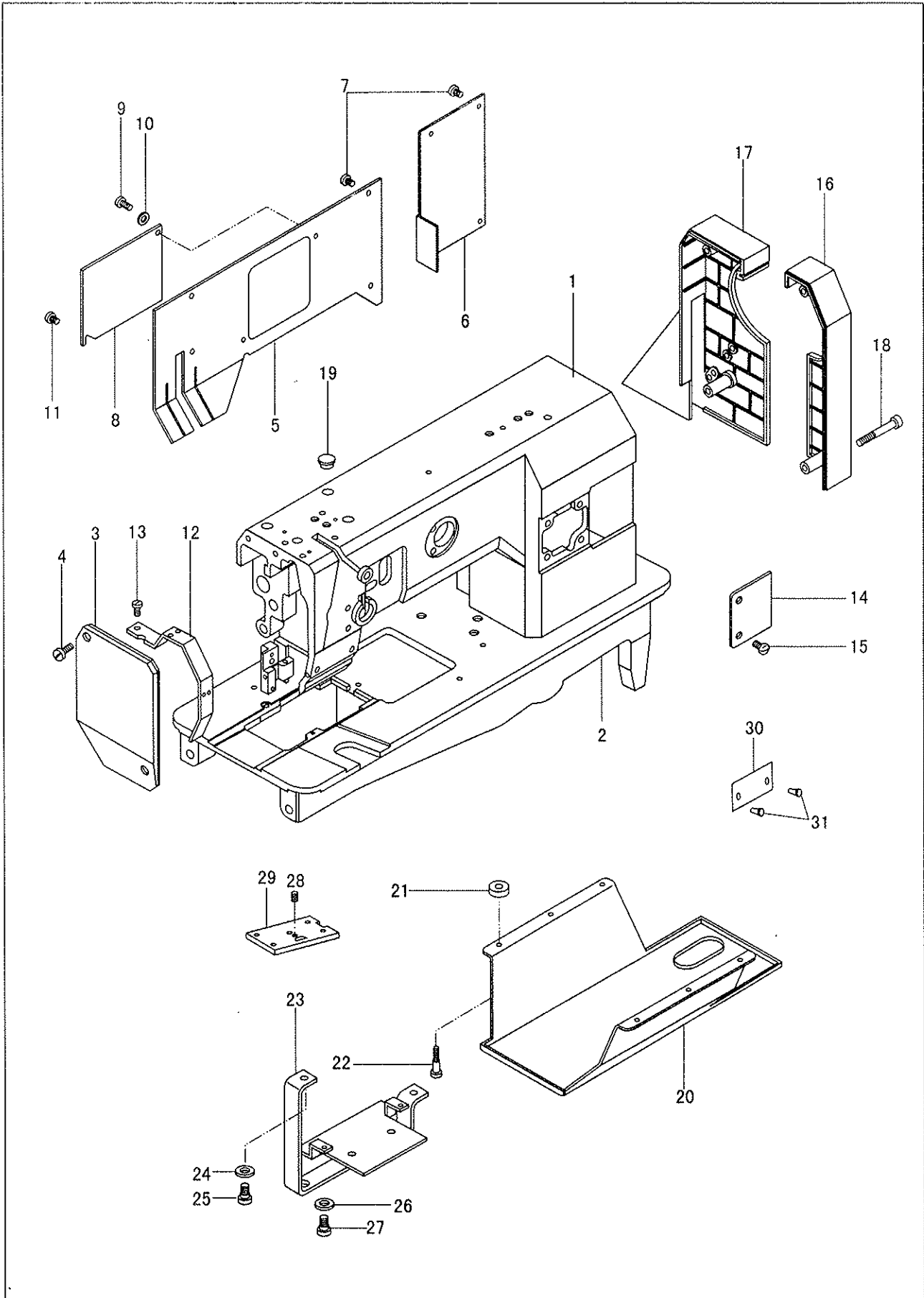

1. Machine casting components

No.	Parts No.	Name of parts	Qty.	Remarks
1	71WF2-001	Arm	1	
2	177WF2-004	Bed	1	
3	71WF2-003	Face plate	1	
4		Screw, face plate	2	GB65-M5×16
5	71WF2-004	Back cover (L)	1	
6	71WF2-005	Back cover (R)	1	
7		Screw	8	GB67-M5×8
8	71WF2-006	Cover (small)	1	
9	71WF2-007	Screw (1)	1	
10		Spring washer	1	GB1972-80
11		Screw (2)	1	GB67-M4×6
12	71WF2-008	Thread take-up lever guard	1	
13		Screw	1	GB67-M5×8
14	177WF2-014	Front cover	1	
15		Screw	2	GB67-M5×8
16	71WF5-005	Safety guard (1)	1	
17	71WF5-006	Safety guard (2)	1	
18		Set screw	4	GB70-85 M5×35
19	71WF2-025	Plug	2	
20	71WF5-007	Oil pan	1	
21	71WF5-008	Washer	6	
22		Screw	6	GB845 ST2.9×19-C-Z
23	71WF2-010	Oil box set bracket complete	1	
24		Washer	2	GB861.1-87 6
25		Screw	2	GB70-85 M6×12
26		Washer	2	GB96-85 4
27		Screw	2	GB65-M4×8
28		Screw	1	GB/T 73 M5×3
29	71WF2-036	Slide plate	1	
30	7WF4-034	Model label	1	
31		Rivet	2	GB827 2

2. Needle and presser foot components

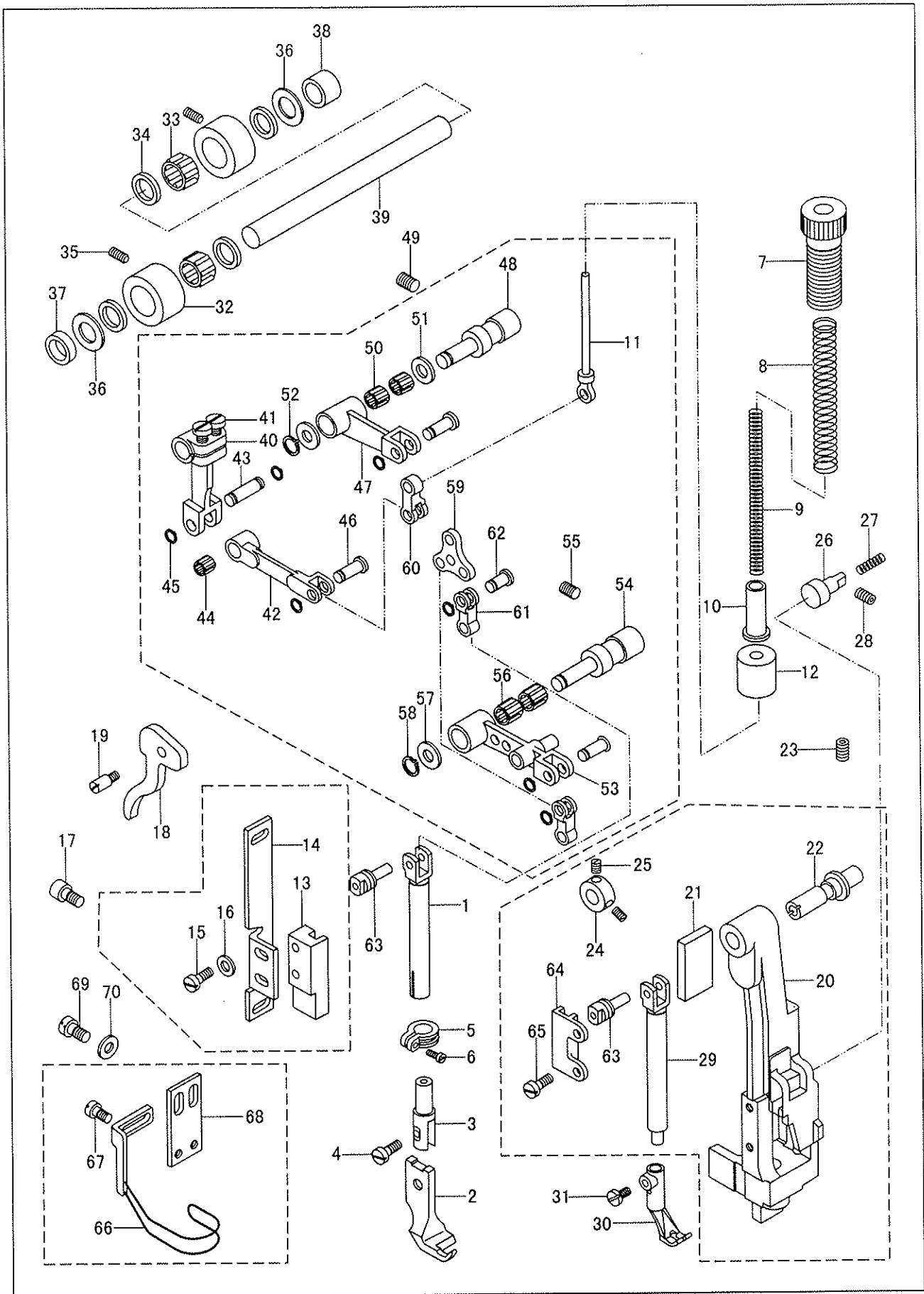

2. Needle and presser foot components

No.	Parts No.	Name of parts	Qty.	Remarks
1	71WF4-001	Presser foot bar	1	
2	71WF4-002	Presser foot	1	
3	71WF4-003	Presser foot connector	1	
4	71WF4-004	Screw	1	
5	71WF4-005	Collar	1	
6	19WF1-013B	Screw	1	
7	71WF4-006	Screw	1	M15×1
8	71WF4-007	Spring (big)	1	
9	71WF4-008	Spring (small)	1	
10	71WF4-009	Spring bushing	1	
11	71WF4-010	Guide bar	1	
12	71WF4-011	Oil felt	1	
13	71WF4-012	Slide guide	1	
14	71WF4-013	Set plate	1	
15		Screw	2	GB65-M4×10
16		Washer	2	GB97.1-4
17		Screw	2	GB70-M5×10
18	71WF4-014	Presser foot lifting bar	1	
19	71WF4-015	Lifting bar shaft	1	
20	71WF3-003	Needle bar rocking frame	1	
21	71WF3-004	Oil felt	1	
22	71WF3-005	Hinge pin	1	
23		Screw	1	GB77-M6×8
24	71WF3-006	Collar	1	
25	13WF1-029	Screw	2	M3×3
26	71WF3-007	Pin	1	
27	71WF3-008	Spring	1	
28		Screw	1	GB77-M5×8
29	71WF3-015	Walking foot bar	1	
30	71WF3-016	Walking foot	1	
31	71WF3-017	Screw	1	SM17/64"×28
32	71WF3-018	Upper feed bushing	2	
33		Bearing	2	Φ10×Φ13×9.7
34	71WF3-019	Stop ring	4	
35		Screw	2	GB77-M6×5
36	71WF3-020	Washer	2	
37	71WF3-021	Washer (front)	1	
38	71WF3-022	Washer (rear)	1	
39	71WF3-023	Upper feed shaft	1	
40	71WF3-024	Upper feed crank (1)	1	

2. Needle and presser foot components

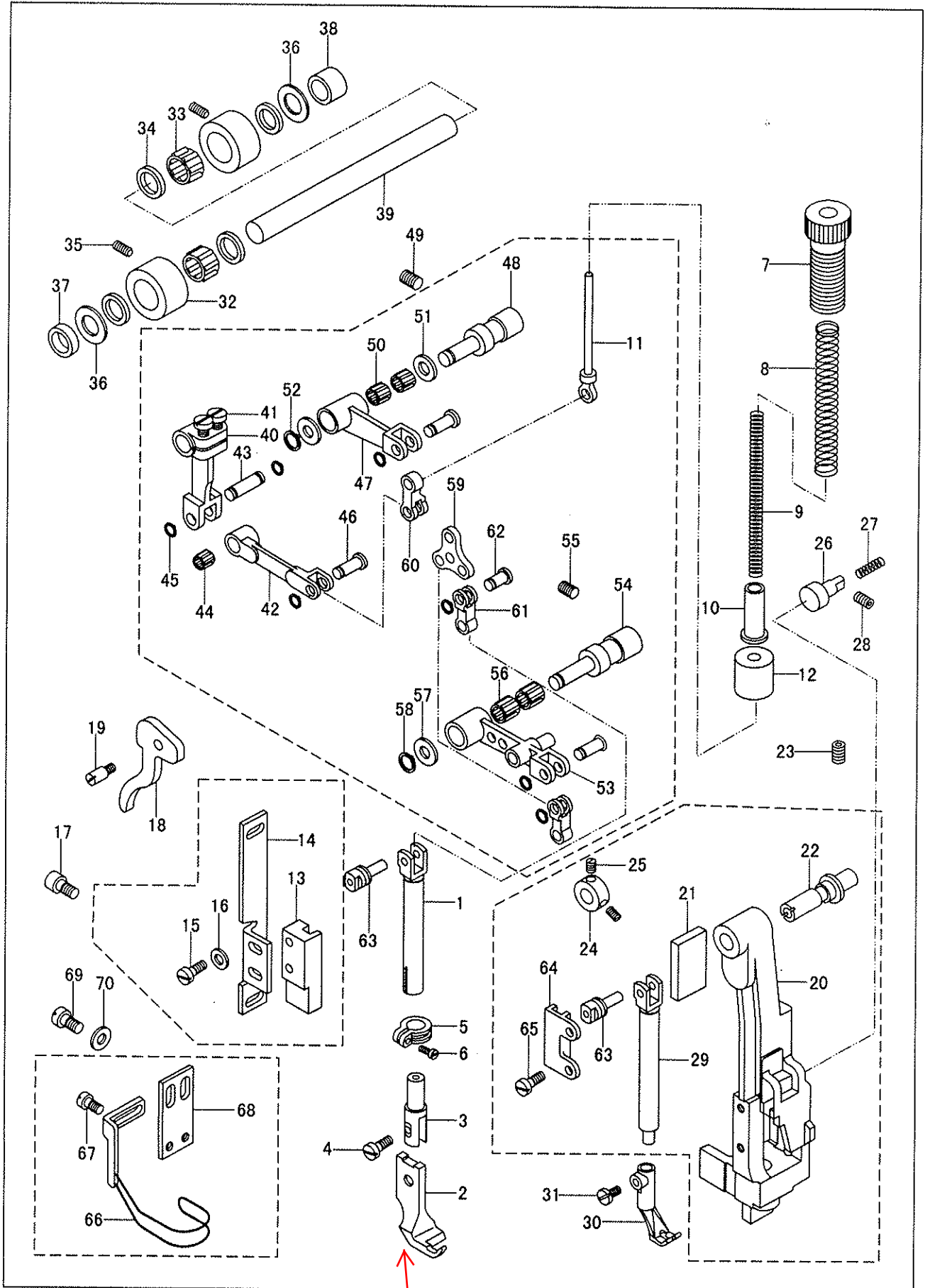

1245-46970 Fuß 2 Schenklig

2. Needle and presser foot components

No.	Parts No.	Name of parts	Qty.	Remarks
41		Screw	2	GB65-M5×12
42	71WF3-025	Presser foot lifting link	1	
43	71WF3-026	Pin	1	
44		Bearing	1	φ5×φ8×7.7
45		Spring	6	GB894.1-5
46	71WF3-027	Pin (long)	3	
47	71WF3-028	Upper feed crank (II)	1	
48	71WF3-029	Pin shaft	1	
49		Screw	1	GB77-M6×8
50		Bearing	2	φ6×φ9×7.7
51	71WF3-030	Washer	2	
52		Spring	1	GB894.1-6
53	71WF3-031	Upper feed crank (III)	1	
54	71WF3-032	Pin shaft	1	
55		Screw	1	GB77-M6×8
56		Bearing	2	φ7×φ10×7.5
57	71WF3-033	Washer	1	
58		Spring	1	GB894.1-7
59	71WF3-034	Movable plate	1	
60	71WF3-035	Link	1	
61	71WF3-036	Presser foot link	2	
62	71WF3-037	Pin (short)	1	
63	71WF3-038	Slide block	1	
64	71WF3-039	Slide guide	1	
65		Screw	2	GB65-M4×8
66	71WF2-022	Finger guard	1	
67	71WF2-023	Screw	2	GB65-M4×8
68	71WF2-024	Finger guard set plate	1	
69		Screw	2	GB65-M5×8
70		Washer	2	GB97.1-5

3. Presser foot lifting components

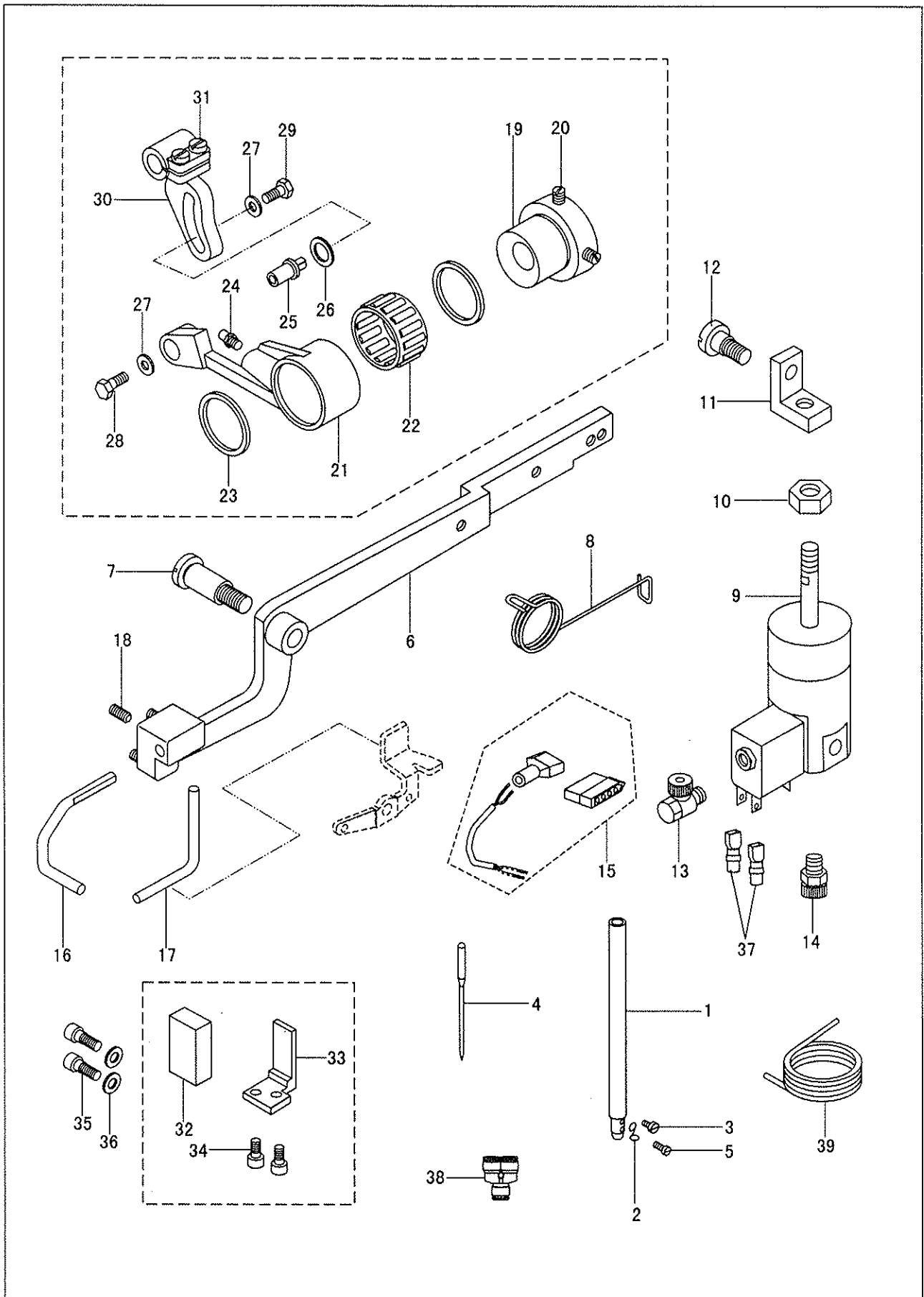

3. Presser foot lifting components

No .	Parts No .	Name of parts	Qty.	Remarks
1	71WF1-001	Needle bar	1	
2	71WF1-002	Needle bar thread guide	1	
3	13WF1-015	Screw	1	M3×5
4		Needle	1	DP×35 LR 23"
5	71WF1-003	Needle set screw	1	M3×5
6	71WF4-016	Knee lifter lever	1	
7	71WF4-017	Screw	1	
8	71WF4-018	Spring	1	
9	177WF8-001	Knee lifer cylinder	1	
10	93WF8-034	Nut	1	GB/T6172.1 M8
11	177WF8-002	Joint	1	
12	177WF8-003	Screw	1	
13	177WF5-007	Joint	1	
14	93WF9-008	Silencer	1	
15	177WF8-004	Wire assy.	1	
16	71WF4-039	Presser foot lifter bent bar	1	
17	71WF4-040	Release bent bar	1	
18		Screw	3	GB79-M5×5
19	71WF3-040	Presser foot lift cam	1	
20	13WF1-018	Screw	2	M6×0.75
21	71WF3-041	Link	1	
22		Bearing	1	φ22× φ26×12.6
23	71WF3-042	Stop ring	2	
24		Oil cup	1	GB1152-89 M6
25	71WF3-043	Pin	1	
26	71WF3-044	Washer	1	
27	71WF3-045	Washer	2	
28		Screw	1	GB5781-M5×8
29		Screw	1	GB5781-M5×10
30	71WF3-046	Adjusting crank	1	
31		Screw	2	GB65-M5×12
32	71WF3-083	Positioning block	1	
33	71WF3-084	Set bracket	1	
34		Screw	2	GB70-M4×8
35		Screw	2	GB70-M4×16
36		Washer	2	GB97.1-4
37	80WF8-005	Cover	2	
38	177WF8-006	Joint	1	APY 6
39		Air pipe	1	

4. Thread take-up and thread tension components

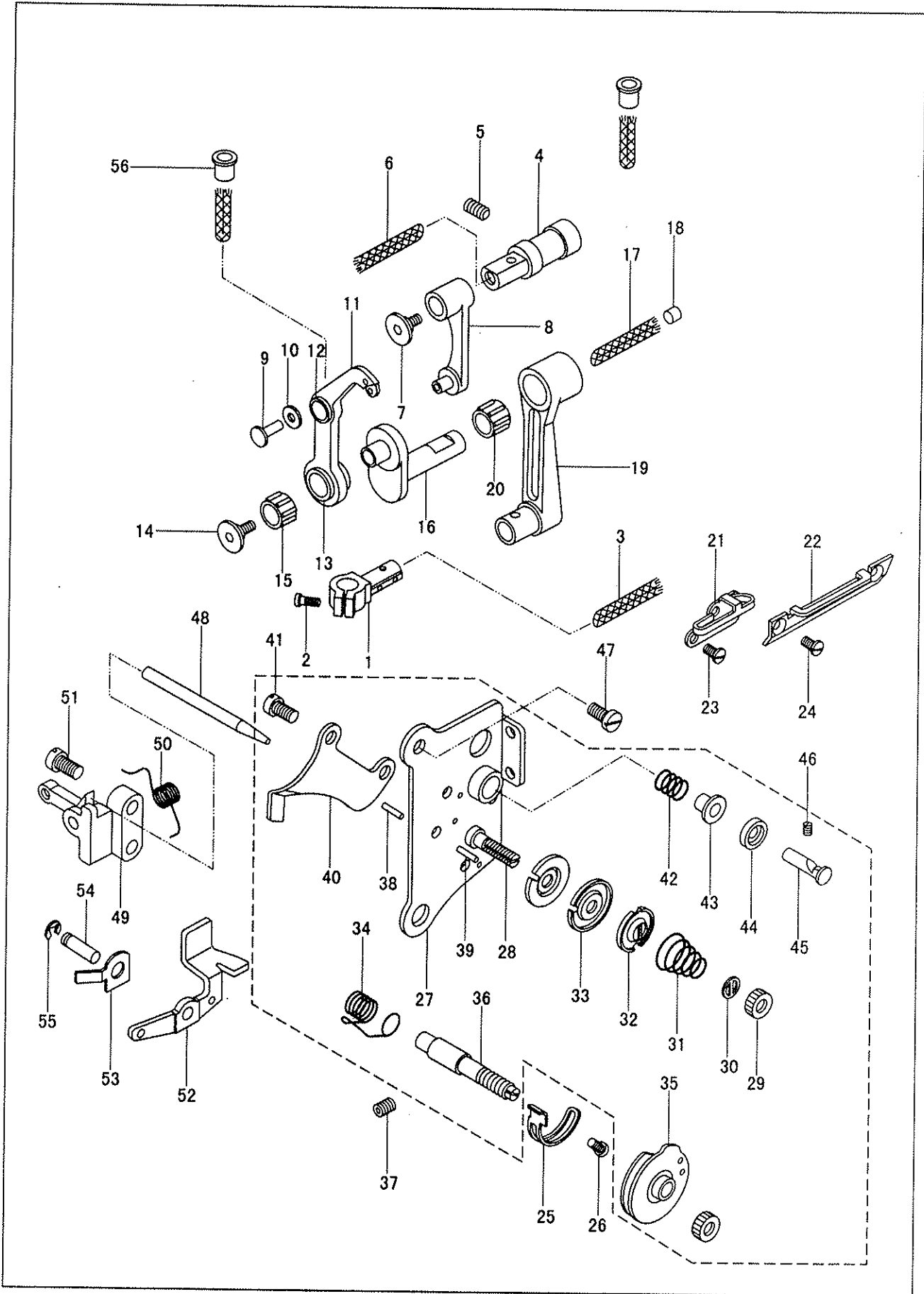

4. Thread take-up and thread tension components

No.	Parts No.	Name of parts	Qty.	Remarks
1	71WF1-004	Needle bar connector	1	
2	71WF1-005	Screw	1	M4×10
3		Oil wick	1	
4	71WF1-006	Pin shaft	1	
5		Screw	1	GB77-M6×8
6		Oil wick	1	
7	71WF1-007	Screw	1	
8	71WF1-008A	Crank	1	
9	71WF1-008B	Stud	1	
10	71WF1-008C	Washer	1	
11	71WF1-008D	Thread take-up lever	1	
12	71WF1-008E	Link bushing	1	
13	71WF1-008F	Bearing bushing	1	
14	71WF1-007	Screw	1	
15		Bearing	1	φ7×φ10×7.5
16	71WF1-009	Hinge shaft	1	
17		Oil wick	1	
18	71WF1-010	Plug	1	
19	71WF1-011	Needle bar link	1	
20		Bearing	1	φ9×φ12×12.7
21	71WF2-011	Thread guide(middle)	1	
22	71WF2-012	Thread guide (lower)	1	
23	71WF2-013	Screw	1	M5×7
24		Screw	1	GB68-M4×8
25	71WF2-016	Stop plate	1	
26		Screw	1	GB65-M4×6
27	71WF2-021A	Set plate	1	
28	71WF2-021B	Bolt	1	
29	71WF2-021C	Nut	2	
30	71WF2-021D	Washer	1	
31	71WF2-021E	Spring	1	
32	71WF2-021F	Tension release disc	1	
33	71WF2-021G	Thread tension disc	2	
34	71WF2-021H	Thread take-up spring	1	
35	71WF2-021I	Thread control plate assy.	1	
36	71WF2-021J	Bolt	1	
37		Screw	1	GB77-M5×8
38	71WF2-021K	Thread guide pin	2	
39	71WF2-021L	Thread release pin	1	
40	71WF2-021M	Thread release plate	1	
41	71WF2-021N	Screw	2	SM9/64"×40
42	71WF2-021O	Spring	1	
43	71WF2-021P	Thread tension cap	1	
44	71WF2-021Q	Thread tension disc	1	
45	71WF2-021R	Pin	1	
46		Screw	1	GB73-M4×8
47		Screw	1	GB67-M4×10
48	71WF2-022	Thread release bar	1	
49	71WF4-033	Thread release bracket assy.	1	
50	71WF4-034	Spring	1	
51	71WF4-035	Screw	2	M5×6
52	71WF4-036	Thread release lever	1	
53	71WF4-037	Spring plate	1	
54	71WF3-053	Lever stud	1	
55		Split ring	1	GB896-86 5
56	71WF2-026	Oil pipe	2	

5. Feed adjustment components

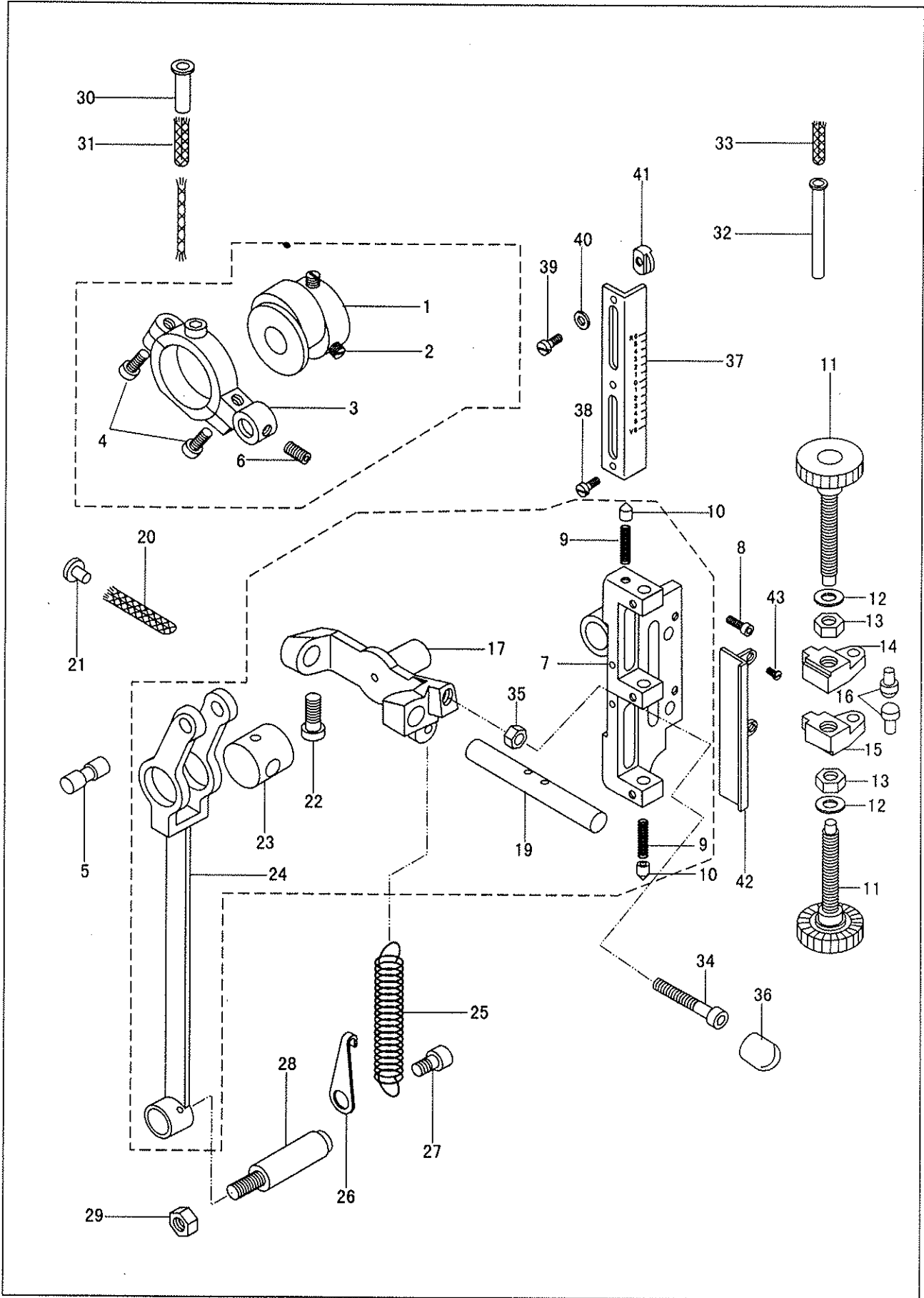

5. Feed adjustment components

No.	Parts No.	Name of parts	Qty.	Remarks
1	71WF3-047	Feed cam	1	
2	22T2-005B3	Screw	2	SM1/4"×40
3	71WF3-048	Feed crank	1	
4		Screw	2	GB70-M5×12
5	71WF3-049	Link stud	1	
6		Screw	1	GB77-M4×5
7	177WF3-001	bracket	1	
8		Screw	2	GB/T70.1 M6×16
9	177WF3-009	Spring	2	
10	177WF3-010	Pin shaft	2	
11	177WF3-007	Screw bar	2	
12	71WF3-044	Washer	2	
13	93WF8-034	Nut	2	GB/T 6172.1 M8
14	177WF3-006	Crank (upper)	1	
15	177WF3-013	Crank (lower)	1	
16	177WF3-011	Padding	2	
17	177WF3-002	Stitch length adjusting bracket	1	
19	71WF3-059	Shaft	1	
20		Oil wick	1	
21	71WF1-013	Oil plug	1	
22	71WF3-060	Screw	1	
23	71WF3-061	Feed slide block	1	
24	71WF3-062	Feed link	1	
25	71WF3-063	Reset spring	1	
26	71WF3-064	Spring hook	1	
27		Screw	1	GB70-85 M6×10
28	71WF3-013	Pin	1	
29	71WF3-014	Nut	1	SM17/64"×28
30	71WF2-027	Oil pipe	1	
31		Oil wick	1	
32	71WF2-028	Oil pipe	1	
33		Oil wick	1	
34		Screw bar	1	GB/T70.1 M8×70
35	177WF3-004	Nut	1	
36	177WF3-003	Handle	1	
37	177WF3-005	Stitch length label	1	
38		Screw	3	GB/T65 M4×5
39		Screw	2	GB/T65 M4×4
40		Washer	2	GB/T848 4
41	177WF3-012	Block	2	
42	177WF3-008	Plate	1	
43		Screw	2	GB/T65 M4×5

6. Upper shaft and rocking shaft components

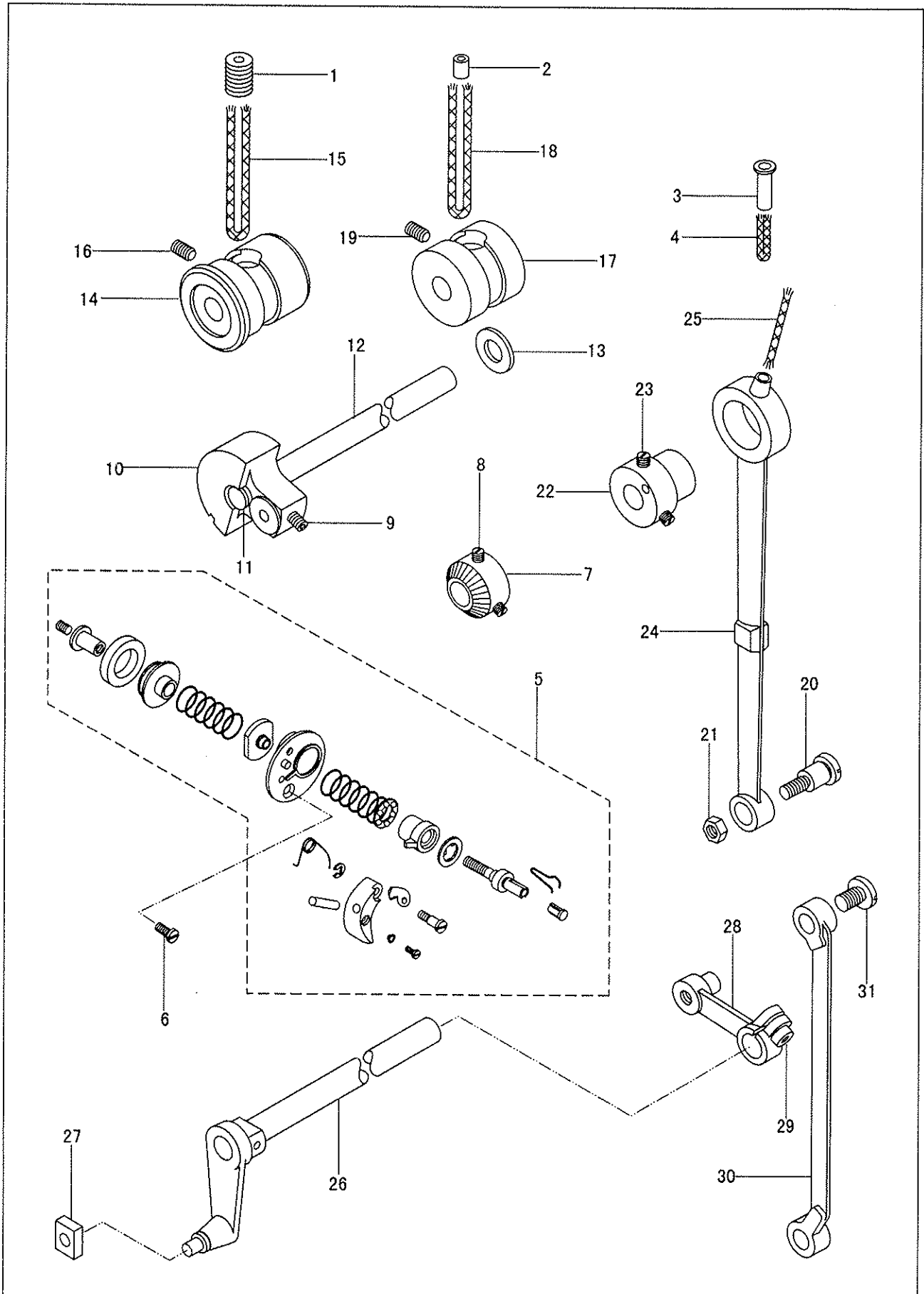

6. Upper shaft and rocking shaft components

No.	Parts No.	Name of parts	Qty.	Remarks
1	71WF2-029	Oil plug	1	
2	71WF2-030	Oil plug	1	
3	71WF2-027	Oil pipe	1	
4		Oil wick	1	
5	177WF2-005	Bobbin thread winder assy.	1	
6		Screw	1	GB68-M4×8
7	71WF2-035	Friction wheel	1	
8	13WF1-027	Screw	2	M6×0.75
9		Screw	2	GB77-M6×5
10	71WF1-012	Needle bar crank	1	
11	71WF1-013	Oil plug	1	
12	71WF1-014	Upper shaft	1	
13	71WF1-015	Washer	1	
14	71WF1-016	Upper shaft bushing (L)	1	
15		Oil wick	1	
16		Screw	1	GB77-M6×8
17	71WF1-017	Upper shaft bushing (M)	1	
18		Oil wick	1	
19		Screw	1	GB77-M6×8
20	71WF3-078	Screw	1	
21	71WF3-079	Nut	1	SM11/64"×28
22	71WF3-080	Feed dog lift cam	1	
23	71WF3-081	Screw	2	
24	71WF3-082	Feed dog lift link	1	
25		Oil wick	1	
26	71WF3-001	Needle bar rocking frame	1	
27	71WF3-002	Slide block	1	
28	71WF3-009	Crank	1	
29		Screw	1	GB70-M8×16
30	71WF3-010	Link	1	
31	71WF3-011	Screw	1	SM17/64"×32

7. Timing belt components

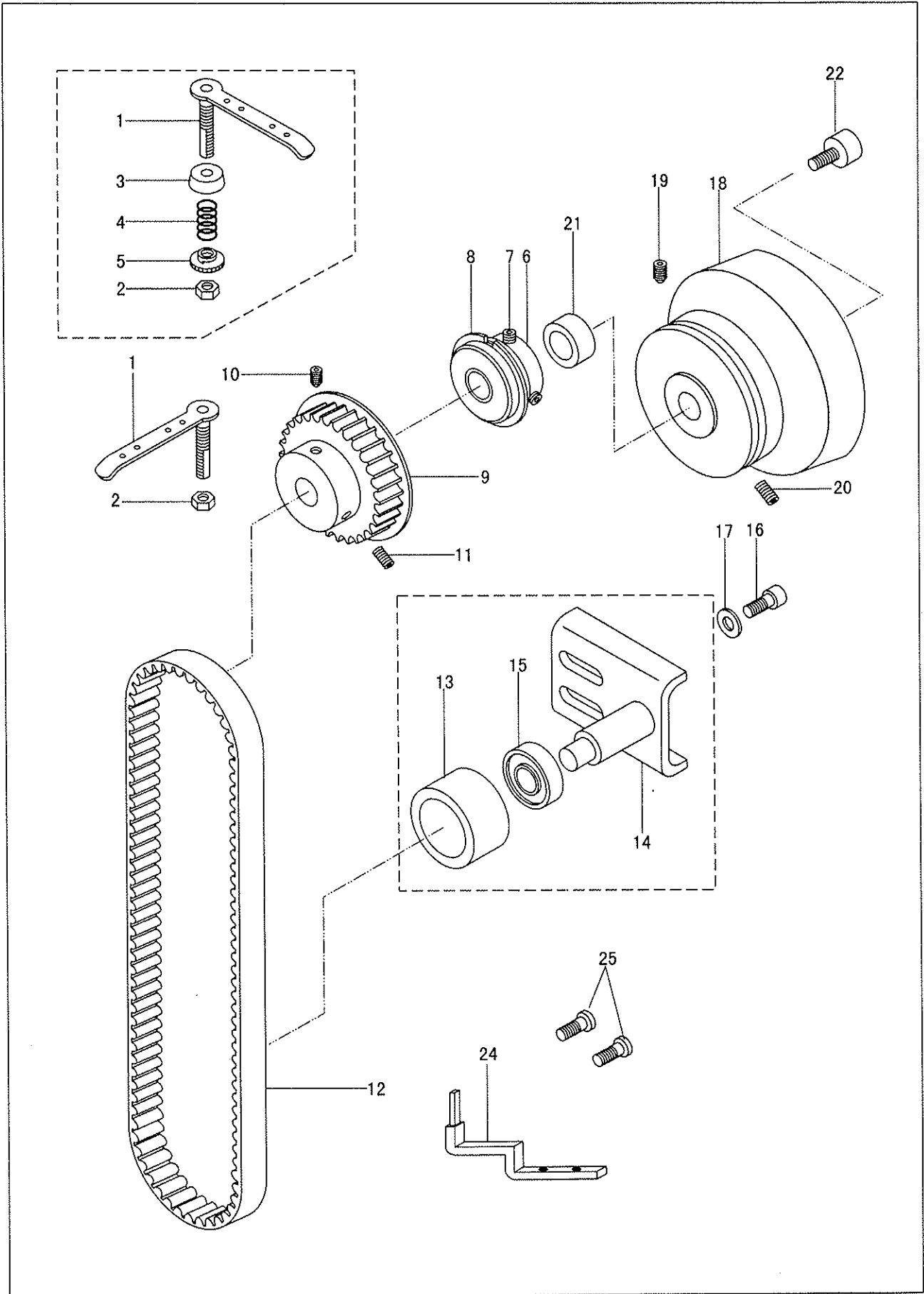

7. Timing belt components

No.	Parts No.	Name of parts	Qty.	Remarks
1	71WF2-014	Thread guide bar assy.	2	
2		Nut	2	GB6170-M6
3	71WF2-015A	Thread tension disc	1	
4	71WF2-015B	Thread tension spring	1	
5	71WF2-015C	Nut	1	
6	71WF1-018	Collar	1	
7	19WF3-005	Screw	2	M6×0.75
8		Bearing	1	6002-2ZNR 15×32×9
9	71WF1-019	Timing pulley assy.	1	
10		Screw	1	GB78-M6×0.75
11		Screw	1	GB77-M6×0.75
12		Timing belt	1	270H063
13	71WF1-021A	Tension wheel	1	
14	71WF1-021B	Tension wheel bracket	1	
15		Bearing	1	6000-2Z
16		Screw	2	GB70-M5×12
17		Washer	2	GB97.1-5
18	177WF1-001	Hand wheel	1	
19		Screw	1	GB78-M6×0.75
20		Screw	1	GB77-M6×0.75
21	71WF1-023	Washer	1	
22	100WF7-001	Screw bar	1	
24	100WF7-002	Synchronizer fixed bracket	1	
25	13WF2-040	screw	2	M4×8

8. Hook saddle components

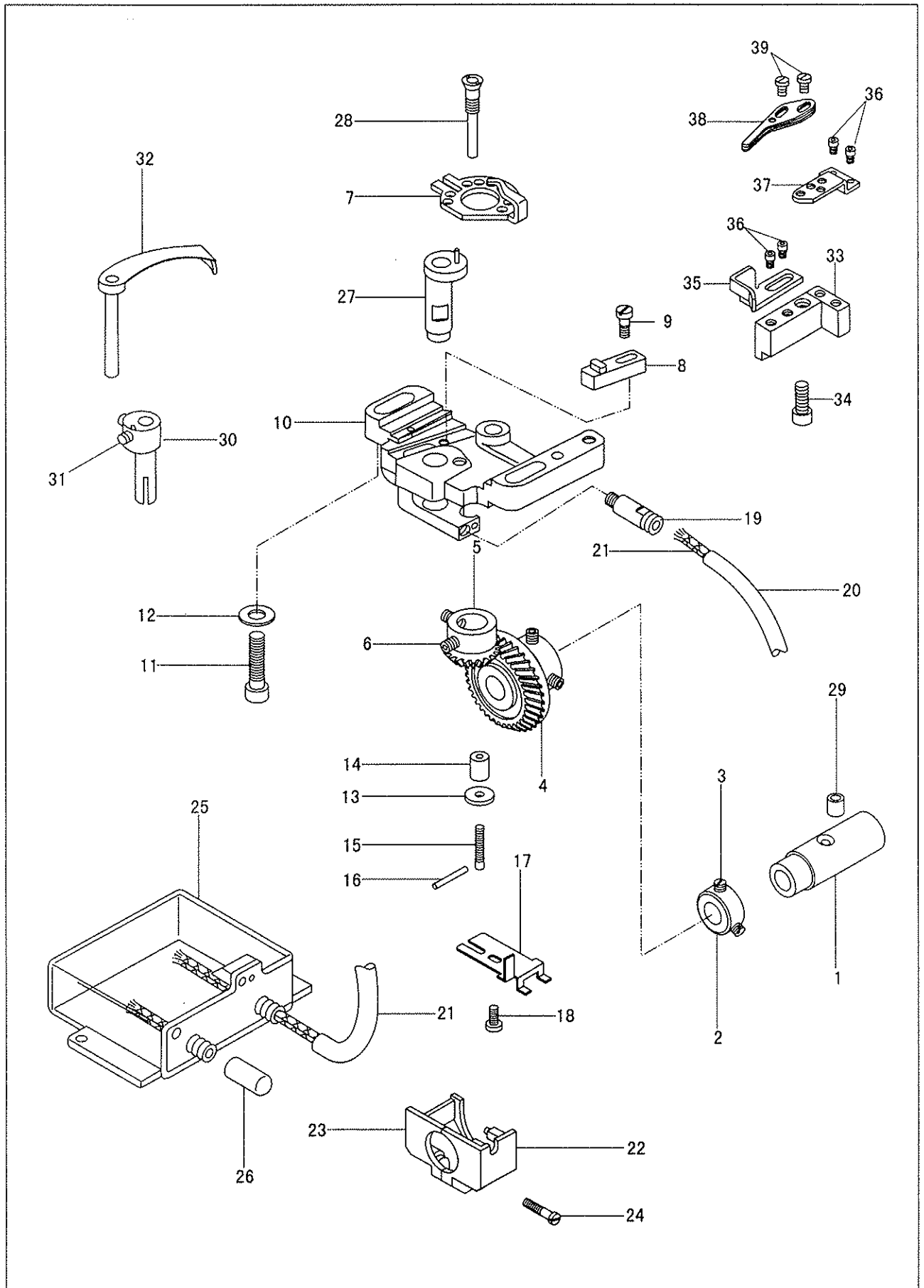

8. Hook saddle components

No.	Parts No.	Name of parts	Qty.	Remarks
1	71WF1-028	Lower shaft bushing (L)	1	
2	71WF1-031	Collar	1	
3	22WF4-005	Screw	2	M5
4	71WF1-032	Lower shaft gear	1	
5	71WF1-033	Hook gear	1	
6	19WF3-005	Screw	4	M6×0.75
7	71WF1-034	Bobbin thread opener	1	
8	71WF1-035	Adjusting plate assy.	1	
9		Screw	1	GB65-M4×8
10	177WF1-002	Hook saddle	1	
11		Screw	2	GB70-85 M6×25
12	71WF1-037	Washer	2	
13	71WF1-038	Oil felt (1)	1	
14	71WF1-039	Oil felt (2)	1	
15	71WF1-040	Screw bar	1	
16		Pin	1	GB879-86 1×16
17	71WF1-041	Cover	1	
18		Screw	1	GB65-M4×8
19	71WF1-042	Connector	1	
20	71WF1-043	Oil pipe	1	
21		Oil wick	1	φ3 L=400
22	71WF1-044	Gear cover (1)	1	
23	71WF1-045	Gear cover (2)	1	
24		Screw	1	GB65-M4×14
25	71WF1-047	Oil box	1	
26	71WF1-049	Oil hole cover	1	
27	71WF1-061	Hook shaft	1	
28	71WF1-062	Screw	1	
29	71WF2-030	Oil plug	1	
30	177WF6-021	Movable knife shaft	1	
31		Screw	2	GB/T80 M4×5
32	177WF6-020	Movable knife	1	
33	177WF6-022	Fixed knife carrier	1	
34		Screw	1	GB/T70.1 M4×16
35	177WF6-030	Fixed knife	1	
36		Screw	4	GB/T70.1 M3×6
37	177WF6-028	Thread holding spring plate carrier	1	
38	177WF6-031	Thread holding spring plate assy.	1	
39		Screw	2	GB/T67 M2×3

9. Needle plate and hook components

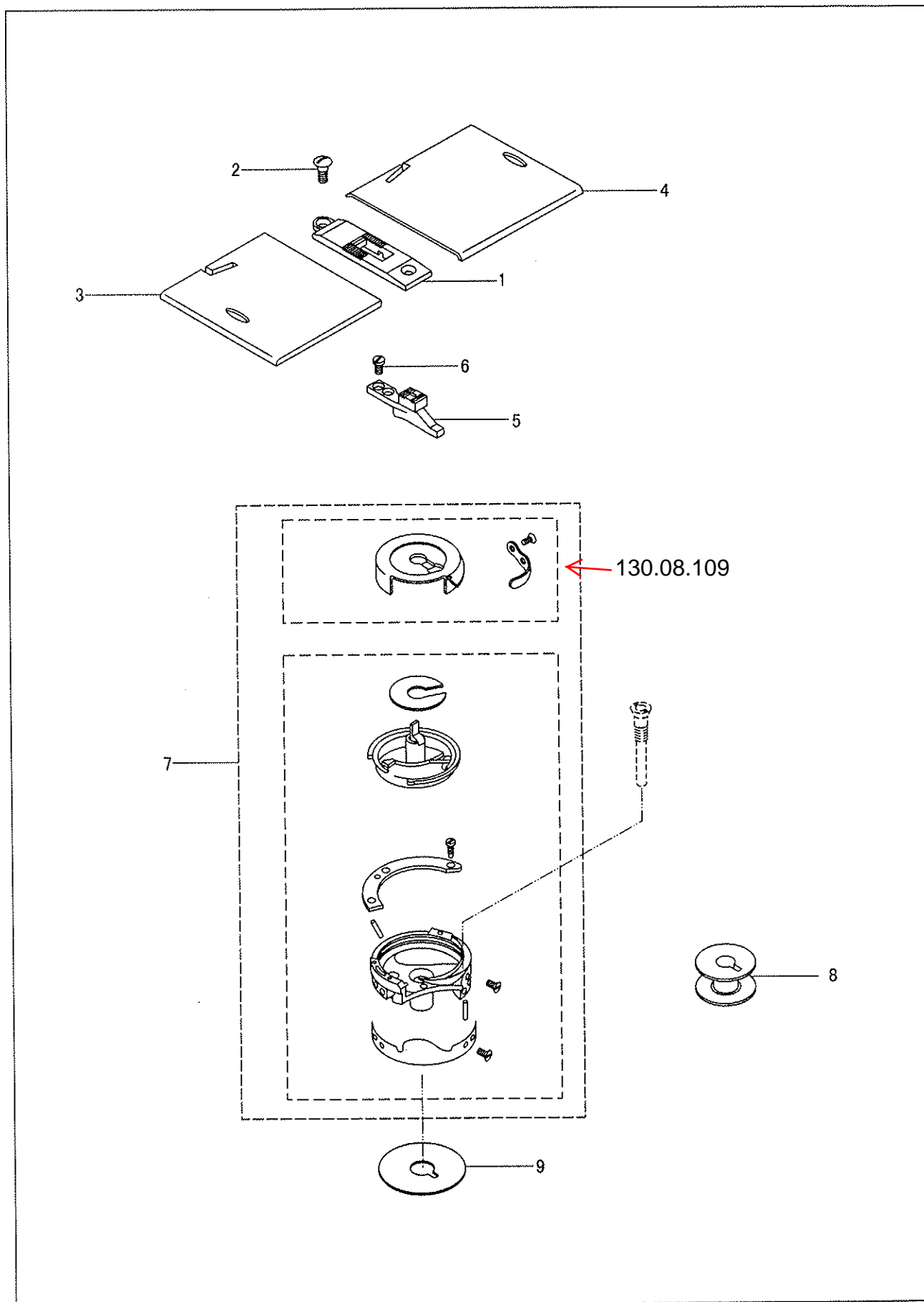

9. Needle plate and hook components

No.	Parts No.	Name of parts	Qty.	Remarks
1	177WF2-002	Needle plate	1	SM11/64"×40
2	71WF2-018	Screw	2	
3	71WF2-019	Slide plate (L)	1	
4	177WF2-015	Slide plate (R)	1	
5	177WF3-014	Feed dog	1	SM1/8"×44
6	J0. 0. 50	Screw	2	
7	177WF1-004	Hook assy.	1	
8	71WF1-046	Bobbin	1	
9	71WF1-060	Washer	1	

10. Lower feed components

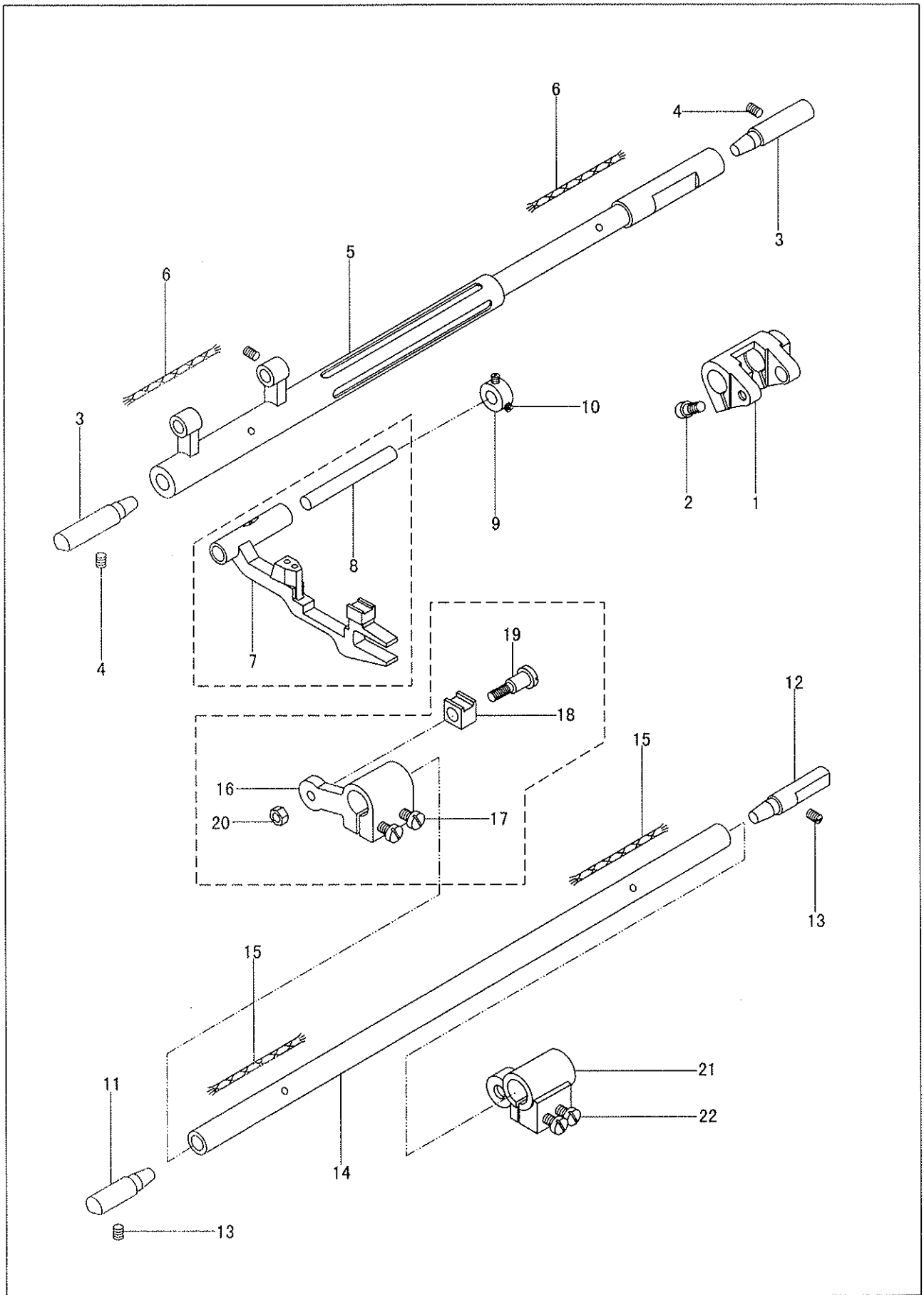

10. Lower feed components

No.	Parts No.	Name of parts	Qty.	Remarks
1	71WF3-012	Feed crank	1	
2		Screw	2	GB65-M5×10
3	71WF3-065	Feed shaft set pin	2	
4		Screw	2	GB77-M6×8
5	71WF3-066	Feed shaft	1	
6		Oil wick	2	φ3
7	71WF3-067	Feed dog carrier	1	
8	71WF3-068	Hinge shaft	1	
9	71WF3-069	Collar	1	
10		Screw	2	GB77-M5×4
11	71WF3-071	Set pin (front)	1	
12	71WF3-065	Set pin (rear)	1	
13		Screw	2	GB77-M6×8
14	71WF3-072	Feed dog lifting shaft	1	
15		Oil wick	2	φ3
16	71WF3-073	Feed dog lifting crank	1	
17		Screw	2	GB65-M5×12
18	71WF3-074	Slide block	1	
19	71WF3-075	Screw	1	
20	71WF3-076	Nut	1	SM11/64"×32
21	71WF3-077	Crank	1	
22		Screw	2	GB65-M5×10

11. Lower shaft components

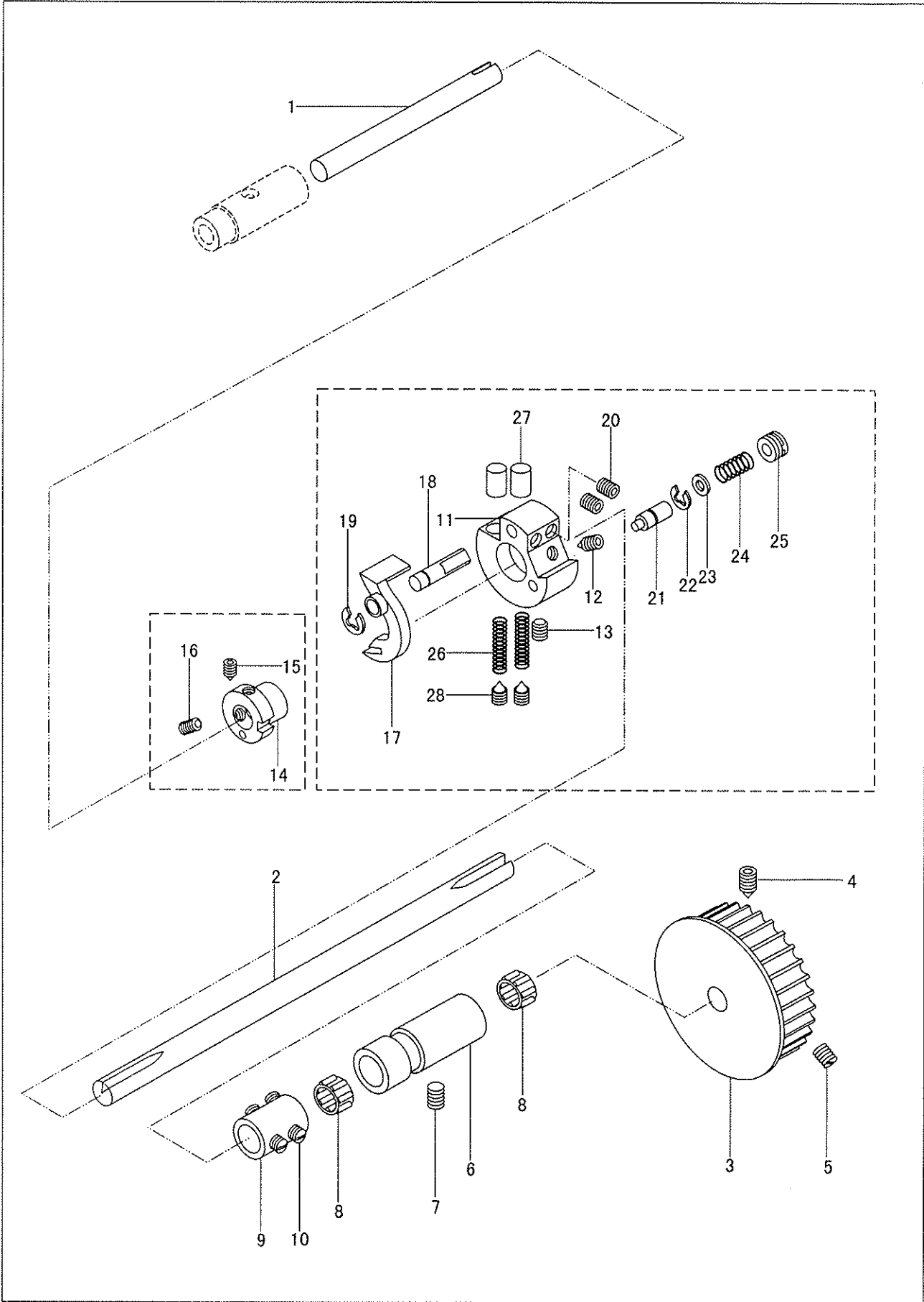

11. Lower shaft components

No.	Parts No.	Name of parts	Qty.	Remarks
1	177WF1-003	Lower shaft (front)	1	
2	71WF1-026	Lower shaft (rear)	1	
3	71WF1-027	Timing pulley assy.	1	
4		Screw	1	GB78-M6×0.75
5		Screw	1	GB77-M6×0.75
6	71WF1-029	Lower shaft bushing (rear)	1	
7		Screw	1	GB77-M6×8
8		Bearing	2	φ10×φ13×9.7
9	71WF1-030	Collar	1	
10	13WF1-027	Screw	4	
11	71WF1-050	Safety clutch body	1	
12		Screw	1	GB78-M6×0.75
13		Screw	1	GB77-M6×0.75
14	71WF1-051	Safety clutch cam	1	
15		Screw	1	GB78-M6×0.75
16		Screw	1	GB77-M6×0.75
17	71WF1-052	Spring plate	1	
18	71WF1-053	Pin	1	
19		Split ring	1	GB896-86 4
20		Screw	2	GB77-M5×6
21	71WF1-054	Stop pin	1	
22		Split ring	1	GB896-86 3
23	71WF1-055	Washer	1	
24	71WF1-056	Spring	1	
25	71WF1-057	Screw	1	
26	71WF1-058	Spring	2	
27	71WF1-059	Spring bushing	2	
28		Screw	2	GB78-M6×0.75

12. Auto-reverse stitching components

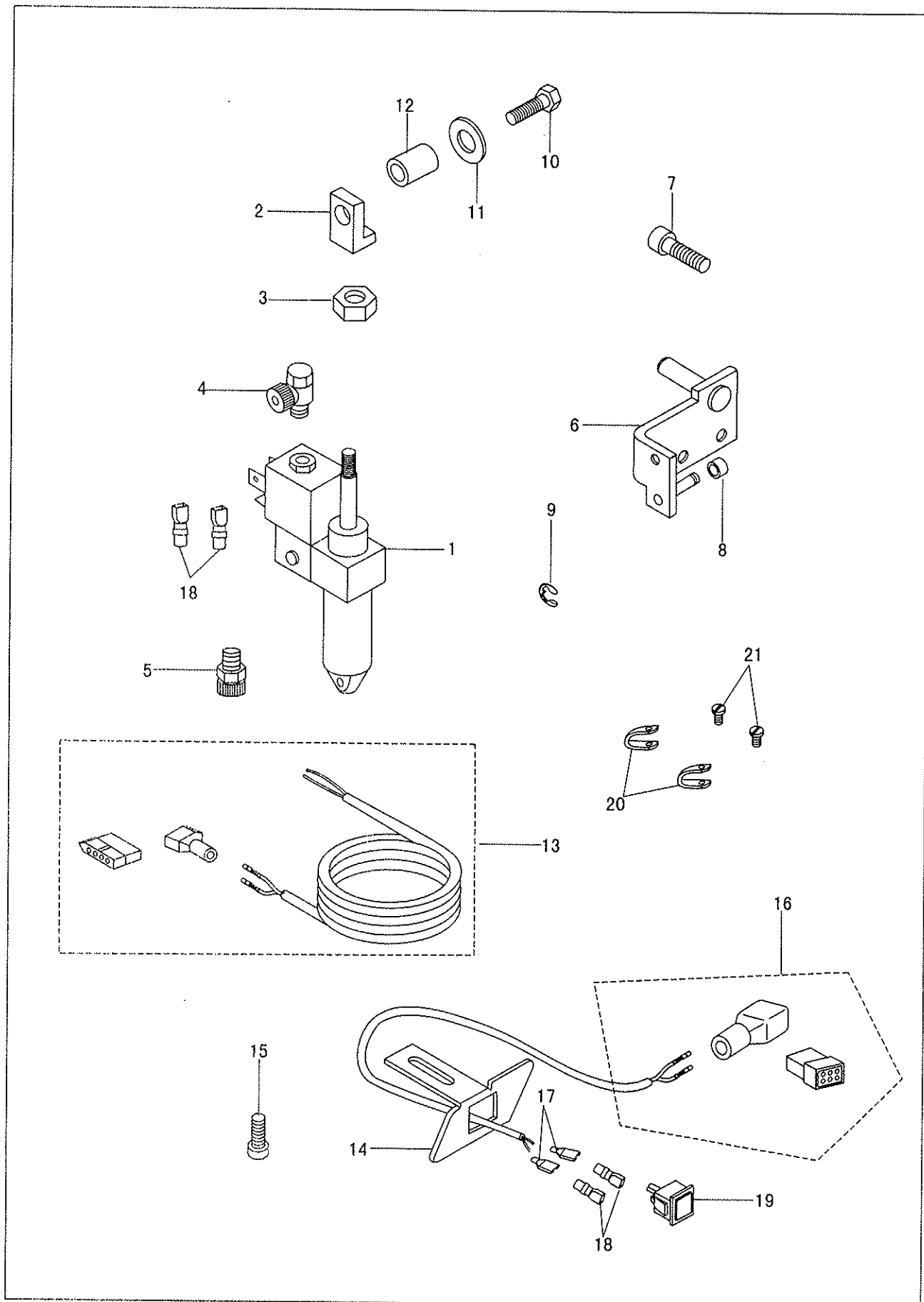

12. Auto-reverse stitching components

No .	Parts No .	Name of parts	Qty.	Remarks
1	177WF5-001	Cylinder	1	
2	177WF5-002	Joint	1	
3		Nut	1	GB/T6172.1 M5
4	177WF5-007	Joint	1	
5	93WF9-008	Silencer	1	
6	177WF5-003	Bracket	1	
7		Screw	2	GB/T70.1 M5×12
8	177WF5-004	Washer	1	
9		Spring	1	GB896 4
10		Screw	1	GB/T5783 M6×16
11	7WF5-049	Washer	1	
12	177WF5-005	Washer	1	
13	177WF5-009	Wire assy.	1	
14	177WF5-006	Carrier for reverse stitching switch	1	
15		Screw	2	GB/T70.1 M5×10
16	177WF5-008	Wire assy.	1	
17	80WF8-004	Joint	2	
18	80WF8-005	Cover	4	
19	119WF8-019	Switch button	1	
20	80WF2-020	Clamp	2	
21	16WF1-059	Screw	2	SM9/64×40

13. Automatic thread trimmer components

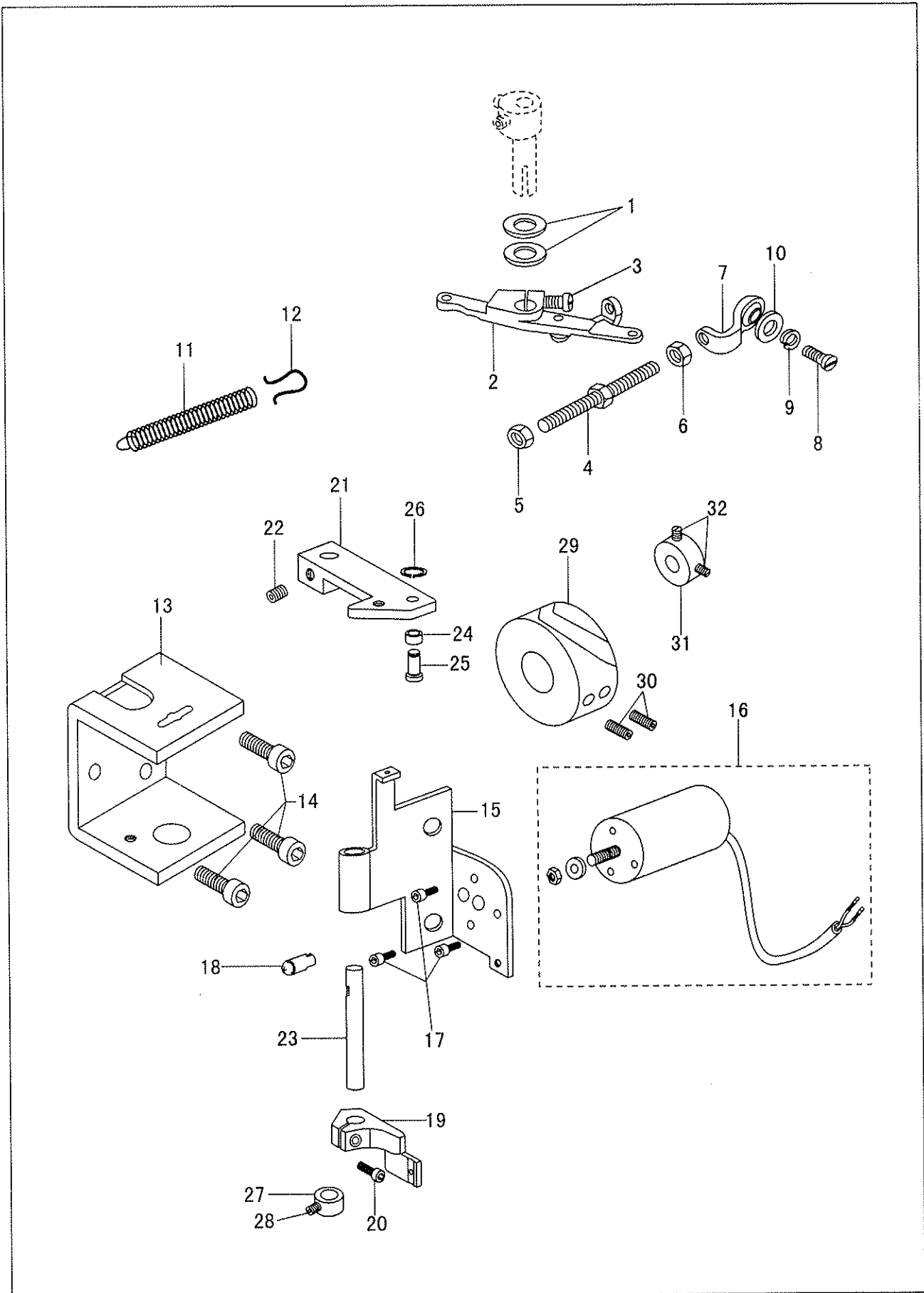

13. Automatic thread trimmer components

No.	Parts No.	Name of parts	Qty.	Remarks
1	177WF6-023	Washer	2	
2	177WF6-024	Driving crank assy.	1	
3		Screw	1	GB/T70.1 M5×10
4	177WF6-025	Screw bar	1	
5	177WF6-032	Nut	1	M6
6		Nut	4	GB/T6170 M6
7	177WF6-026	Bracket assy.	1	
8		Screw	1	GB/T65 M6×16
9		Spring washer	1	GB93 6
10	27WF3-007	Washer	1	
11	177WF6-027	Reset spring	1	GB/T97.2 6
12	177WF6-050	Spring hook	1	
13	71WF4-025	Knee lifter base	1	
14		Screw	3	GB/T70.1 M8×16
15	177WF6-041	Solenoid carrier	1	
16	177WF6-042	Solenoid assy.	1	
17		Screw	3	GB/T70.1 M4×6
18	177WF6-043	Block	1	
19	177WF6-044	Crank	1	
20	80WF6-028	Screw	1	M5×12
21	177WF6-045	Driving crank	1	
22	36WF5-025	Screw	2	SM11/64"×40
23	177WF6-046	Shaft	1	
24	177WF6-048	Roller	1	
25	177WF6-049	Pin shaft	1	
26		Spring	1	GB896 3.5
27	228WF4-007	Retaining ring	1	
28	36WF5-025	Screw	2	SM11/64"×40
29	177WF6-047	Thread trimming cam	1	
30	72WF2-014	Screw	4	M6×8
31	177WF6-040	Collar	1	
32	80WF6-036	Screw	2	M5×5

14. Tension release components

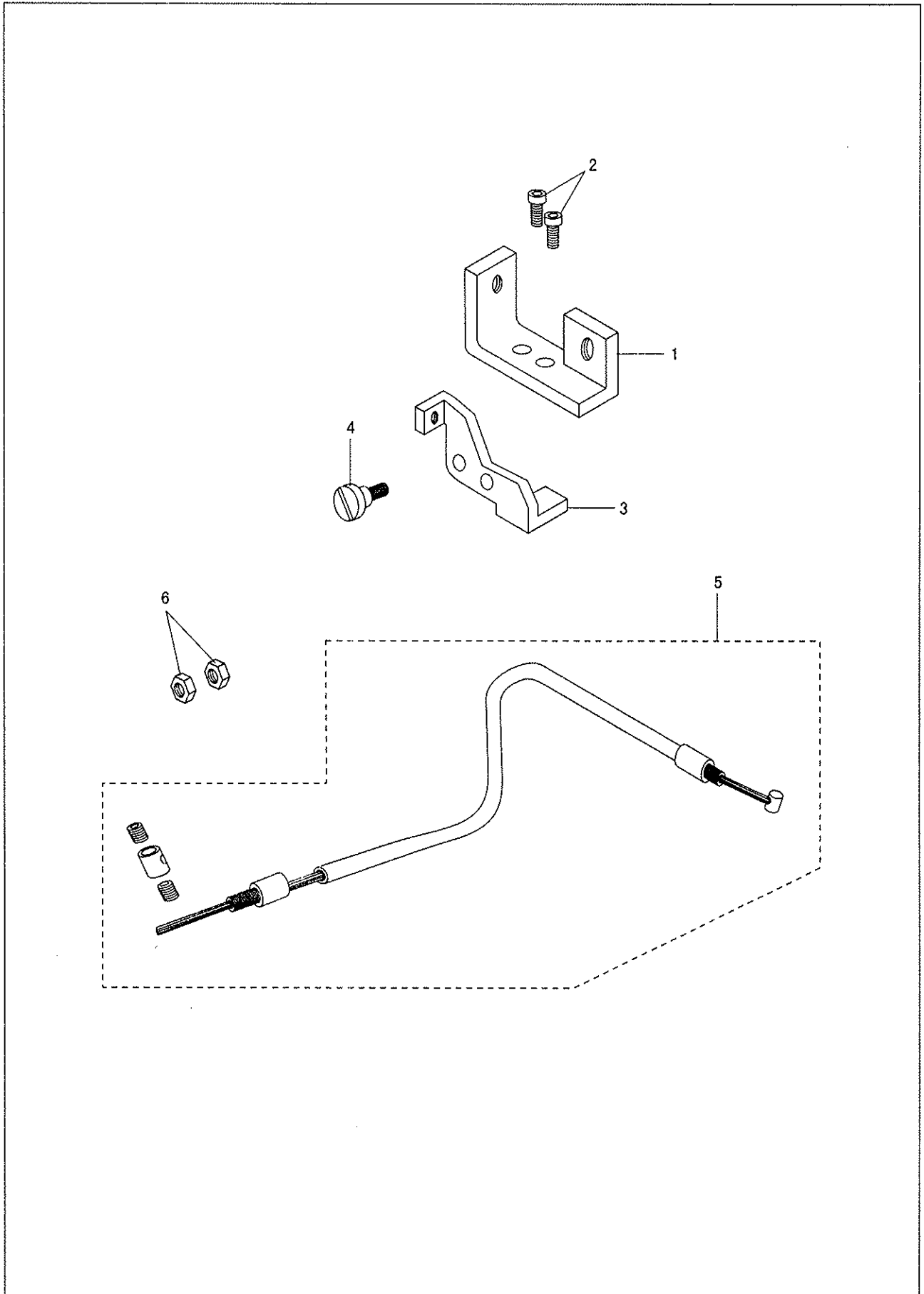

15. Accessories (1)

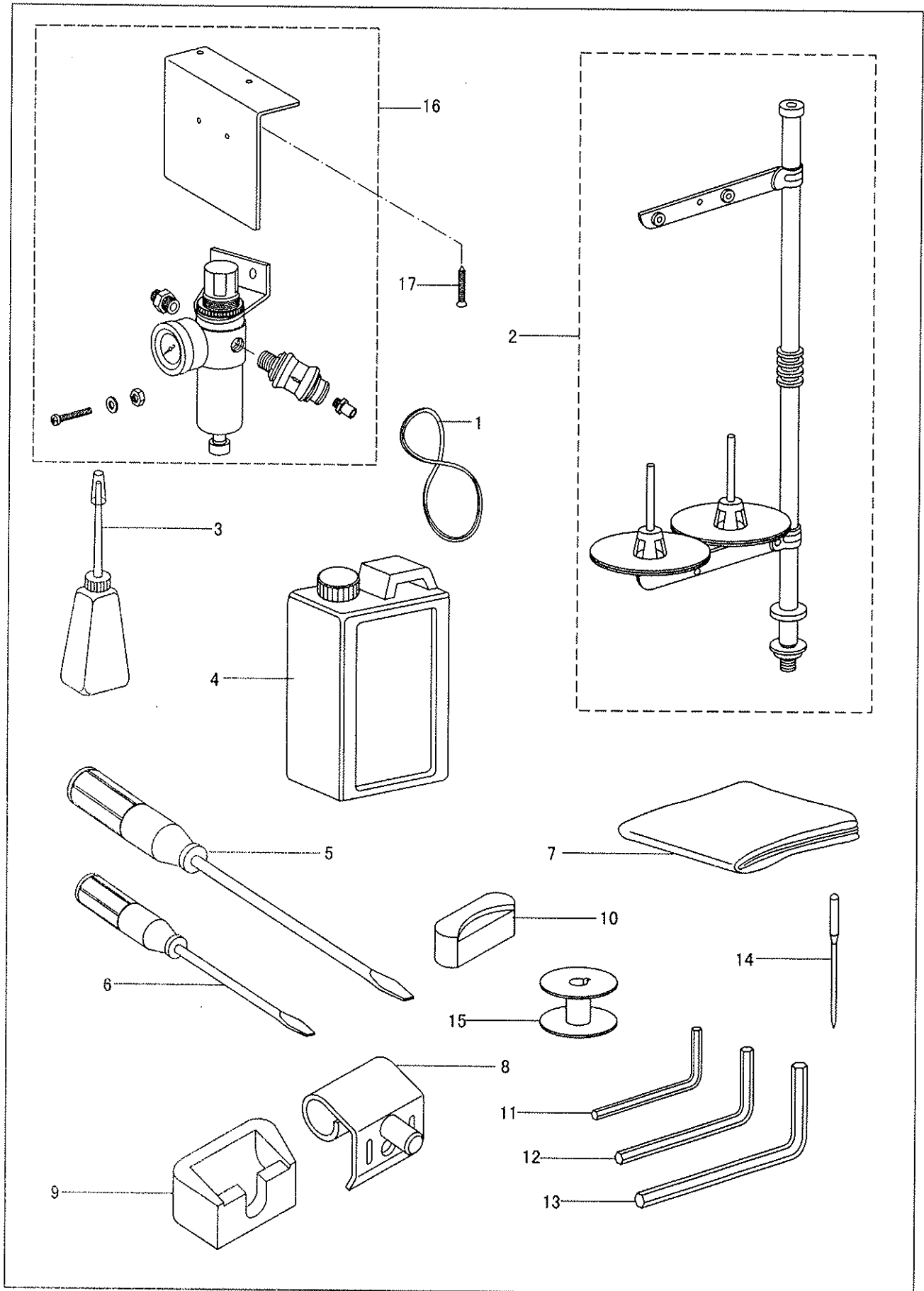

15. Accessories (I)

No .	Parts No .	Name of parts	Qty.	Remarks
1		V-belt	1	M41
2	4F-007	Thread stand assy.	1	
3	33TF-011	Oil pot	1	
4	1F-009	Oil tank	1	
5	33TF-013	Screwdriver (M)	1	
6	33TF-014	Screwdriver (S)	1	
7	1F-013	Machine cover	1	
8	71WF5-009	Machine head hinge assy.	2	
9	71WF5-010	Cushion cover	2	
10	71WF5-011	Rubber padding	2	
11		Wrench	1	S=2.5mm
12		Wrench	1	S=3mm
13		Wrench	1	S=4mm
14		Needle	3	DP×35 23#
15	71WF1-046	Bobbin	3	
16	177WF10-006	Integrator assy.	1	
17		Screw	2	GB/T845 ST3.5×12

15. Accessories (II)

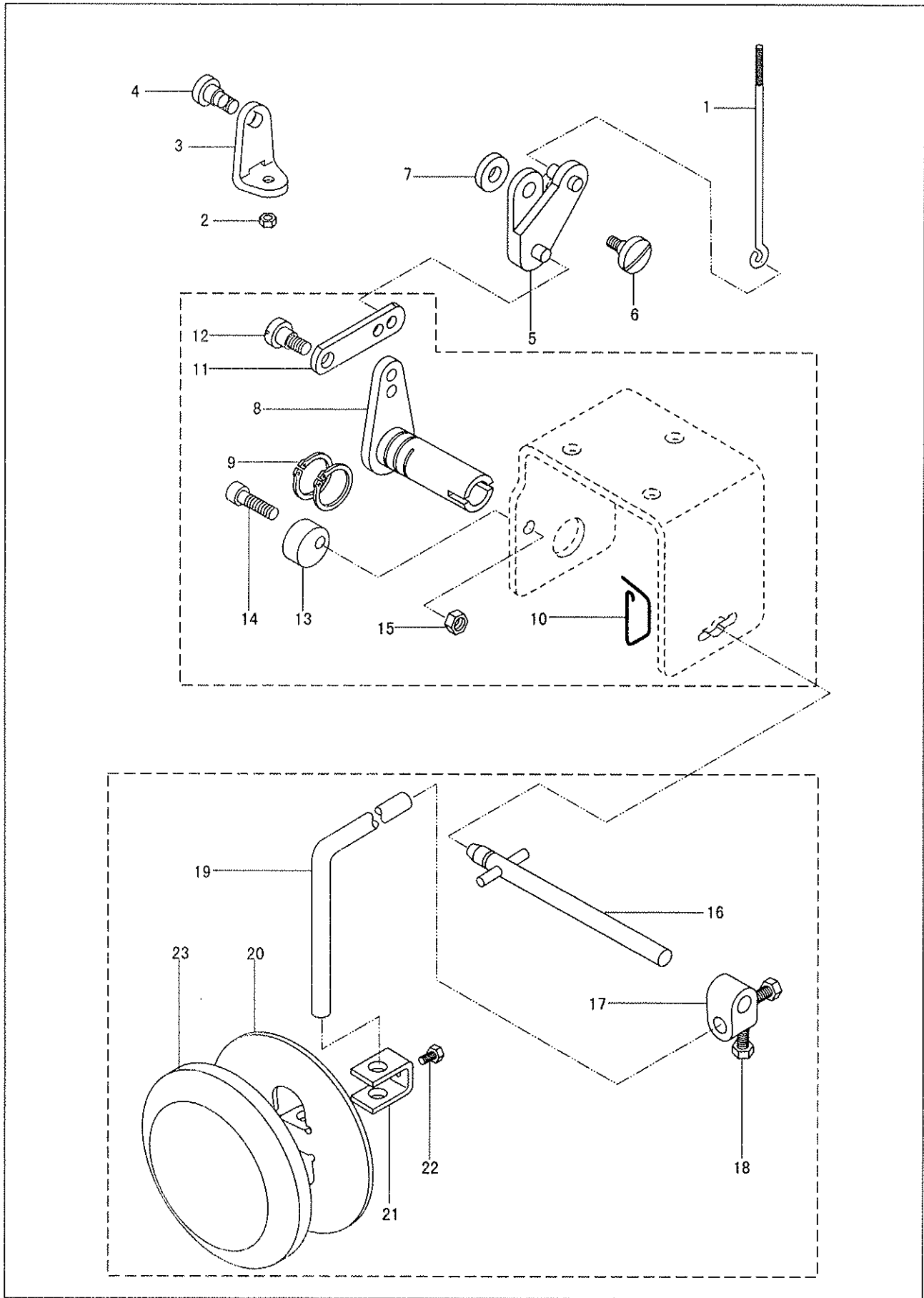

15. Accessories (II)

No.	Parts No.	Name of parts	Qty.	Remarks
1	71WF4-019	Knee lifter drawing bar	1	
2		Nut	1	GB/T6170 M5
3	71WF4-020	Connector	1	
4	71WF4-021	Screw	1	
5	71WF4-022	Movable plate assy.	1	
6	71WF4-023	Screw	1	
7	71WF4-024	Washer	1	
8	71WF4-027	Knee lifter crank assy.	1	
9		Stop ring	2	GB894.1-86 18
10	71WF4-028	Spring	1	
11	71WF4-029	Knee lifter crank link	1	
12	71WF4-030	Screw	1	
13	71WF4-031	Stop block	1	
14		Screw	1	GB70-M6×20
15		Nut	1	GB/T6170 M6
16	71WF6-001	Knee lifter shaft assy.	1	
17	71WF6-002	Knee lifter crank	1	
18	22T9-003B4	Screw	2	SM5/16"×18
19	22T9-003B2	Knee press bar	1	
20	22T9-003B5	Knee press plate	1	
21	22T9-003B6	Knee press rod bracket	1	
22	22T9-003B7	Screw	1	
23	22T9-003B8	Knee press plate pad	1	

- Please don't adjust and repair the machine by non-professionals, except adjusting stitch.
- Specifications subject to change without notice

TYPICAL SEWING MACHINE WANPING MACHINERY CO.,LTD.

ADD: WANPING TOWN, WUJIANG CITY, JIANGSU

PROVINCE, CHINA

TEL: +86-512-63391278

FAX: +86-512-63391371

POST. CODE: 215223

[Http://www.typicalwpchina.com](http://www.typicalwpchina.com)

E-mail: export@typicalwpchina.com