



Models

# AP26M

Rev 2 Updated December 30 2024(wr)

## Technical Manual & Parts Lists



CPU Controller models

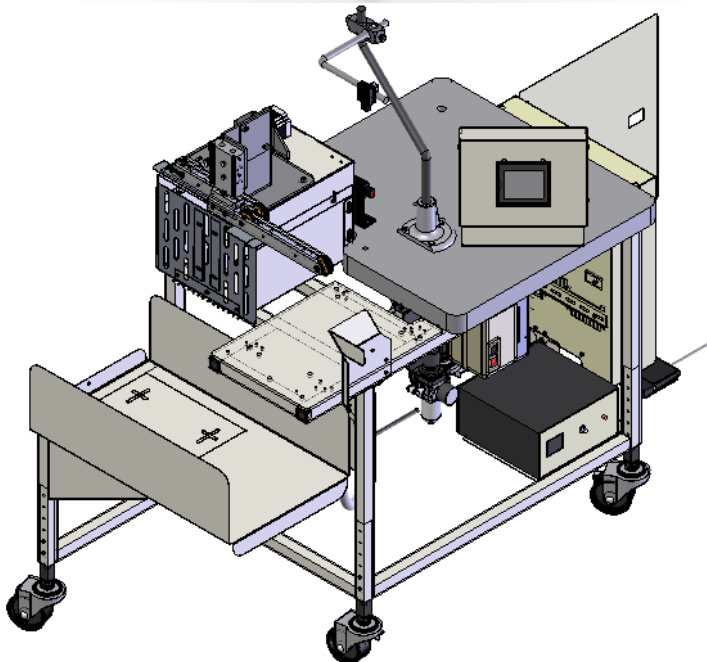

PLC Controller models

**Atlanta Attachment Company**

362 Industrial Park Drive

Lawrenceville, GA 30046

770-963-7369 • [www.atlatt.com](http://www.atlatt.com)

# ATLANTA ATTACHMENT COMPANY, INC.

## Confidential and Proprietary Information

The materials contained herein are confidential and proprietary information of Atlanta Attachment Company. In addition to any confidentiality and non-disclosure obligations that currently exist between you and Atlanta Attachment Company, your use of these materials serves as an acknowledgment of the confidential and proprietary nature of these materials and your duty not to make any unauthorized use or disclosure of these materials.

All materials contained herein are also protected by United States Copyright law and may not be used, disclosed, reproduced, distributed, published, or sold without the express written consent of Atlanta Attachment Company, which consent may be withheld in Atlanta Attachment Company's sole discretion. You may not alter or remove any copyright, trademark, or other notice from copies of these materials.

This equipment may be protected by one or more US and foreign patents.

For a complete list visit  
[atlatt.com/patents.php](http://atlatt.com/patents.php)



## IMPORTANT

**It is important to read and understand the information contained within this manual before attempting to operate the machine. Atlanta Attachment Co., Inc. shall not be held liable for damage resulting from misuse of the information presented within, and reserves the right to change the information contained within, without prior notification.**

# Contents

Important Safety Instruction .....	0
Liability .....	1
Safety Equipment on the Machines .....	2
Protective Eyewear .....	3
Important Notices.....	4
Maintenance .....	6
Repair .....	7
A Word to the End User.....	8
Safety Precautions.....	8
Description.....	10
Installation.....	11
Operation.....	12
AP26M Trouble shooting .....	15
Routine Maintenance .....	17
Thread Cutter Adjustment, UP-Position Details.....	18
Thread Cutter Adjustment, Down-Position Details .....	19
Efka Motor Parameter Settings,.....	20
Part List Directions .....	21
Assembly Drawings & Parts Lists .....	22
AAP26MG24 Short Sleeve Closer, Pegasus EX5204, Pana .....	23
AAP26MY23 Auto Short Closer, Yamato .....	24
AAP26MY52 Auto Short Sleeve Closer, Yamato AZ8003G-04DA .....	25
AAP26MEG24 Auto Shirt Closer, Efka.....	26
AAP26MEG27P Auto Shirt Closer, PLC with Efka Motor .....	27
26M-G Table Assembly.....	28
26ME-G Table Assembly, Efka.....	30
26ME-GP Table Assembly, PLC with Efka Motor .....	32
1336025 PLC Screen Assembly .....	34
AP-26MGP Console, Generic, Panasonic .....	35
AP-26MEG Console, Generic, Efka.....	37
1975-512A Venturi and Mounting Bracket .....	39
26M-500 Program Controller .....	40
26ME-500 Program Controller.....	42
1336021 PLC Control Box Assembly .....	44
AAE211E-4 4 Station Solenoid Assembly .....	46
AP-26M-03 Conveyor Assembly .....	47
AP-26M-02 Flip Stacker Assembly.....	48

26M-PD Pneumatic Diagram.....	50
26M-WD Wiring Diagram.....	51
26ME-WD Wiring Diagram .....	52
26ME-500WD Wiring Diagram .....	53
26M-500WD Wiring Diagram.....	54
AP26MPLC-WD1.....	55
AP26MPLC-WD2.....	56
Sewing Head Details.....	57
AP-26M-06 Sewing Head Detail .....	57
AP-26M-11 Sewing Head Detail .....	58
AP-26M-13 Sewing Head Detail .....	59
AP-26M-23 Sewing Head Detail .....	60
1975-400G6 Cutter & Footlift, Pegasus Sewing Head.....	61
1975-400S Cutter & Footlift, Yamato AZ8003H Sewing Head.....	62
1975-400S10 Cutter & Footlift, Yamato AZ8003G Sewing Head.....	63
1975-400M Cutter Assembly.....	64
Cutter Adjustments .....	65

## Important Safety Instruction



This part of the Instruction Material is provided for the safe use of your equipment. It contains important information to help work safely with the unit and describes the dangers inherent in machinery. Some of these dangers are obvious, while others are less evident.

### Mandatory Information

All persons operating and/or working on the AP26M, should read and understand all parts of the Safety Instructions. This applies, in particular, for persons who only operate and/or work on the unit occasionally (e.g. for maintenance and repair). Persons who have difficulty reading must receive particularly thorough instruction.

### Scope of the Instruction Material

- The Instruction Material comprises:
- Safety information
- Operator Instructions
- Electrical and Pneumatic diagrams

And may also include;

- A list of recommended spare parts
- Instruction Manual(s) for components made by other manufacturers
- The layout and installation diagram containing information for installation

### Intended Use

Our machines are designed and built-in line with the state of the art and the accepted safety rules. However, all machines may endanger the life and limb of their users and/or third parties and be damaged or cause damage to other property, particularly if they are operated incorrectly or used for purposes other than those specified in the Instruction Manual.

### Exclusion of Misuse



Non-conforming uses include, for example, using the equipment for something other than it was designed for, as well as operation without duly installed safety equipment. The risk rests exclusively with the end user.

Conforming use of the machine includes compliance with the technical data, information, and regulations in all parts of the complete Instruction Material, as well as compliance with the maintenance regulations. All local safety and accident prevention regulations must also be observed.

## Liability

The machine should only be operated when in perfect working order, with due regard for safety and the potential dangers, as well as in accordance with the Instruction Material. Faults and malfunctions capable of impairing safety should be remedied immediately. We cannot accept any liability for personal injury or property damage due to operator errors or non-compliance with the safety instructions contained in this booklet. The risk rests exclusively with the end user.

The Instruction Material should always be kept near the machine so that it is accessible to all concerned.

The local, general, statutory and other binding regulations on accident prevention and environmental protection must also be observed in addition to the Instruction Material. The operating staff must be instructed accordingly. This obligation also includes the handling of dangerous substances and provision/use of personal protective equipment.

The Instruction Material should be supplemented by instructions, including supervisory and notification duties with due regard for special operational features, such as the organization of work, work sequences, the personnel deployed, etc.

The personnel's awareness of the dangers and compliance with the safety regulations should be checked at irregular intervals.

## Choice and Qualification of Personnel

Ensure that work on the machine is only carried out by reliable persons who have been appropriately trained for such work - either within the company, by our field staff or at our office - and who have not only been duly appointed and authorized but are also fully familiar with the local regulations. Work on the machine should only be carried out by skilled personnel, under the management and supervision of a duly qualified engineer.

This not only applies when the machine is used for production, but also for special work associated with its operation (start-up and maintenance), especially when it concerns work on the hydraulic or electrical systems, as well as on the software/serial bus system.

## Training

Everyone working on or with the machine should be duly trained and informed with regard to correct use of the safety equipment, the foreseeable dangers which may arise during operation of the machine and the safety precautions to be taken. In addition, the personnel should be instructed to check all safety mechanisms at regular intervals.

## Responsibilities

Clearly define exactly who is responsible for operating, setting-up, servicing and repairing the machine. Define the responsibilities of the machine operator and authorize him to refuse any instructions by third parties if they run contrary to the machine's safety. This applies, in particular to the operators of machines linked to other equipment. Persons receiving training of any kind may only work on or with the machine under the constant supervision of an experienced operator. Note the minimum age limits permitted by law.

## A Word to the Operator

The greatest danger inherent in our machines: is that of fingers, hands or loose clothing being drawn into a machine by live, coasting or rotating tools or assemblies or of being cut by sharp tools or burned by hot elements.

### **ALWAYS BE CONSCIOUS OF THESE DANGERS!**

## Safety Equipment on the Machines



All machines are delivered with safety equipment, which shall not be removed or bypassed during operation.

The correct functioning of safety equipment on machines and systems should be checked every day and before every new shift starts, after maintenance and repair work, when starting up for the first time and when restarting (e.g. after prolonged shutdowns).

If safety equipment must be dismantled for setting-up, maintenance or repair work, such safety equipment shall be replaced and checked immediately upon completing the maintenance or repair work. All protective mechanisms shall be fitted and fully operational whenever the machine is at a standstill or if it has been shut down for a longer period.

## Damage

If any changes capable of impairing safety are observed in the machine or its mode of operation, such as malfunctions, faults or changes in the machine or tools, appropriate steps must be taken immediately, the machine switched off and a proper lockout tagout procedure followed. The machine should be examined for obvious damage and defects at least once per shift. Damage found shall be immediately remedied by a duly authorized person before resuming operation of machine.

The machine should only be operated when in perfect working order and when all protective mechanisms and safety equipment, such as detachable protective mechanisms, emergency STOP systems, etc. are in place and operational.

## Faults or Errors

The machine must be switched off and all moving or rotating parts allowed to come to a standstill and secured against accidental restart before starting to remedy any faults or errors.

## Signs on the Machine

Safety and danger signs on the machine should be observed and checked at regular intervals to ensure that they are complete and undamaged. They should always be clearly visible and legible.

### Clothing, Jewelry, Protective Equipment

Long loose hair, loose-fitting clothes, gloves, and jewelry, including rings, should be avoided in order to prevent injuries due to being caught, drawn in and wound up inside the machine.

## Protective Eyewear

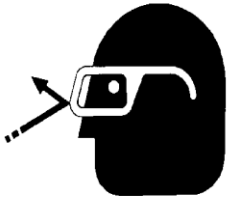

Protective eyewear that has been tested by the local authorities should be worn whenever there is a possibility of loose or flying objects or particles such as when cleaning the machine with compressed air.

## Tools

Always count the number of tools in your possession before starting work on the machine. This will allow you to check that no tools have been left behind inside the machine. Never leave a tool in the machine while working.

## Oils, Lubricants, Chemicals

Note the applicable safety regulations for the product used.

## No Smoking, Fire, Explosion Hazard

Smoking and open flame (e.g. welding work) should be prohibited in the production area due to the risk of fire and explosions.

## Workplace

A clear working area without any obstructions whatsoever is essential for safe operation of the machine. The floor should be level and clean, without any waste.

The workplace should be well lit, either by the general lighting or by local lights.

## Emergency STOP

The emergency STOP buttons bring all machine movements to a standstill. Make sure you know exactly where they are located and how they work. Try them out. Always ensure easy access to the nearest emergency STOP button while working on the machine.

## First Aid

1. Keep calm even when injured.
2. Clear the operator from the danger zone. The decision of what to do and whether to seek additional assistance rests entirely with you, particularly if someone has been trapped.
3. Give First Aid. Special courses are offered by such organizations as the employers' liability insurance association. Your colleagues should be able to rely on you and vice versa.
4. Call an ambulance. Do you know the telephone numbers for the ambulance service, police, and fire service?

## Important Notices

### Reporting and Fighting Fires

Read the instructions posted in the factory with regards to reporting fires and the emergency exits. Make sure you know exactly where the fire extinguishers and sprinkler systems are located and how they are operated. Pass on the corresponding information to the firefighters when they arrive. Ensure there are enough signs to avoid fire hazards.

The following fire extinguishers may be used:

- Dry powder extinguishers, ABC fire-extinguishing powder.
- Carbon dioxide fire extinguishers to DIN 14461 for electronic components. Great care must be exercised when using carbon dioxide fire extinguishers in confined, badly ventilated rooms (see DIN 14406 and 14270).

Isolate the machine from the power supply if a fire breaks out. Do not use water on burning electrical parts until it is certain that they have been completely disconnected from the power supply. Burning oils, lubricants, plastics, and coatings on the machine can give off gases and vapors that may be harmful to your health.

A qualified person should be consulted to repair the damage after a fire.

### Electrical Power Supply

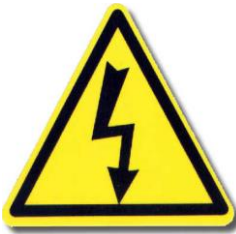

Before undertaking any maintenance or repair work on the machine, switch off the electrical power to the machine at the main source and secure it with a padlock so that it cannot be switched on again without authorization.

In practice, this may mean that the technician, electrician, and operator all attach their own padlock to the master switch simultaneously so that they can carry out their work safely. Locking extension plates should be available for multiple locks if required. The primary purpose for a lockout/tagout procedure is to protect workers from injury caused by unexpected energizing or start-up of equipment.

Energy sources (electrical/pneumatic/hydraulic, etc.) for the equipment shall be turned off or disconnected and the switches locked or labeled with a warning tag. It is the responsibility of the employer to establish control procedures. Follow lockout/tagout procedures before, setup and/or any service or maintenance work is performed, including lubrication, cleaning, or clearance of jams.

**Caution: The machine is still not completely de-energized even when the master switch is off.**

- Electricity - The machine is always isolated from the electrical power supply whenever the master switch has been switched off. However, this does not apply for the power supply in the control cabinet, nor for equipment that does not draw its power via the master switch.
- Pneumatic / hydraulic energy - Almost all our machines carry compressed air. In addition to switching off the master switch, the air supply must also be disconnected, and the machine checked to ensure it is depressurized before starting any work on the machine; otherwise, the machine may execute uncontrolled movements.

- Kinetic energy - Note that some motors or spindles, for example, may continue to run or coast run on after being switched off.

- Potential energy - Individual assemblies may need to be secured if necessary for repair work.

## **Delivery of the Machine/Packaging**

Note any markings on the packaging, such as weights, lifting points and specific information. Avoid temperature fluctuations. Condensation may damage the machine.

## **Transport Damage**

The packaging and machine must immediately be examined for signs of damage in transit. Such damage must be reported to the shipper/transporter within the applicable time limits. Contact Atlanta Attachment Company and/or your transport insurer immediately, if signs of damage are visible. Never operate a damaged machine.

## **Interim Storage**

If the machine must be stored temporarily, it must be oiled or greased and stored in a dry place where it is protected from the weather to avoid damage. A corrosion-inhibiting coating should be applied if the machine must be stored for a longer period and additional precautions taken to avoid corrosion.

## **Transporting the Machine**

Disconnect the machine from all external connections and secure any loose assemblies or parts. Never step under a suspended load. When transporting the machine or assemblies in a crate, ensure that the ropes or arms of a forklift truck are positioned as close to the edge of the crate as possible. The center of gravity is not necessarily in the middle of the crate. Note the accident prevention regulations, safety instructions and local regulations governing transport of the machine and its assemblies.

Only use suitable transport vehicles, hoisting gear and load suspension devices that are in perfect working order and of adequate carrying capacity. Transport should only be entrusted to duly qualified personnel.

Never allow the straps to rest against the machine enclosure and never push or pull sensitive parts of the machine. Ensure that the load is always properly secured. Before or immediately after loading the machine, secure it properly and affix corresponding warnings.

All transport guards and lifting devices must be removed before the machine is started up again. Any parts that are to be removed for transport must be carefully refitted and secured before the machine is started up again.

## **Workplace Environment**

Our machines are designed for use in enclosed rooms: Permissible ambient temperature approx. 5 - 40 °C (40 - 104 °F). Malfunctions of the control systems and uncontrolled machine movements may occur at temperatures outside this range.

Protect against climatic influences, such as electrostatic charges, lightning strikes, hail, storm damage, high humidity, salinity of the air in coastal regions.

Protect against influences from the surroundings: no structure-borne vibrations, no grinding dust, or chemical vapors.

Protect against unauthorized access.

Ensure that the machine and accessories are set up in a stable position.

Ensure easy access for operation and maintenance (Instruction Manual and layout diagram); also verify that the floor is strong enough to carry the weight of the machine.

## Local Regulations

Particular attention must be paid to local and statutory regulations, etc. when installing machines and the plant (e.g. with regard to the specified escape routes). Note the safety zones in relation to adjacent machines.

## Maintenance

### General Safety Instructions

The machine shall be switched off, come to a standstill, and be secured so that it cannot be switched on again inadvertently before starting any maintenance work whatsoever. Use proper lockout/tagout procedures to secure the machine against inadvertent startup.

Remove any oil, grease, dirt, and waste from the machine, particularly from the connections and screws, when starting the maintenance and/or repair work. Do not use any corrosive-cleaning agents. Use lint-free rags.

Retighten all screw connections that must be loosened for the maintenance and repair work. Any safety mechanisms that must be dismantled for setting-up, maintenance or repair purposes must be refitted and checked immediately after completing the work.

### Maintenance, Care, Adjustment

The activities and intervals specified in the Instruction Manual for carrying out adjustments, maintenance and inspections must be observed, and parts replaced as specified.

All hydraulic and pneumatic lines should be examined for leaks, loose connections, rubbing and damage whenever the machine is serviced. Any defects found must be remedied immediately.

### Waste, Disassembly, Disposal

Waste products should be cleared from the machine as soon as possible as not to create a fire hazard. Ensure that fuels and operating lubricants, as well as replacement parts are disposed of in a safe and ecologically acceptable manner. Note the local regulations on pollution control.

When scrapping (disassembling) the machine and its assemblies, ensure that these materials are disposed of safely. Either commission a specialist company familiar with the local regulations or note the local regulations when disposing of these materials yourself. Materials should be sorted properly.

# Repair

## Replacement Parts

We cannot accept any liability whatsoever for damage due to the use of parts made by other manufacturers or due to unqualified repair or modification of the machine.

## Repair, Electrical

The power supply must be switched off (master switch off) and secured so that it cannot be switched on again inadvertently before starting any work on live parts.

Those parts of the machine and plant on which inspection, maintenance or repair work is to be carried out must be isolated from the power supply, if specified. The isolated parts must first be checked to determine that they are truly de-energized before being grounded and short-circuited. Adjacent live parts must also be isolated.

The protective measures implemented (e.g. grounding resistance) must be tested before restarting the machine after all assembly or repair work on electric parts.

Signal generators (limit switches) and other electrical parts on the safety mechanisms must not be removed or bypassed. Only use original fuses or circuit overloads with the specified current rating. The machine must be switched off immediately if a fault develops in the electrical power supply.

The electrical equipment of our machines must be checked at regular intervals and any defects found must be remedied immediately.

If it is necessary to carry out work on live parts, a second person should be on hand to operate the emergency OFF switch or master switch with voltage release in the event of an emergency. The working area should be cordoned off and marked by a warning sign. Only use electrically insulated tools.

## Ventilation/Hazardous Gases

It is the end user's responsibility to ensure adequate ventilation is provided to exhaust all noxious or hazardous gases that may be present in the working environment.

## Hydraulic and Pneumatic Systems

Work on hydraulic or pneumatic equipment shall only be carried out by persons with training, knowledge, and experience of hydraulic systems. Pressure lines shall be depressurized before starting any repair work.

## General Liability

Liability for machine damage and personal injury is extinguished completely if any unauthorized conversions or modifications are undertaken. The machine must not be modified, enlarged, or converted in any way capable of affecting safety without the manufacturer's prior approval.

## Starting Machine Movements

Read the Instruction Manual carefully to establish which keys and functions start machine movements.

## A Word to the End User

The end user has sole responsibility to enforce the use of safety procedures and guards on the machine. Any other safety devices or procedures due to local regulations should be retrofitted in accordance to these regulations and/or the EC Directive on the safety of machines.

Operator's position must always be readily accessible. Escape routes must always be kept clear and safety areas should be identified.

## Safety Precautions

Safety should be a constant concern for everyone. Always be careful when working with this equipment. While normal safety precautions were taken in the design and manufacture of this equipment, there are some potential safety hazards.

**Everyone involved with the operation and maintenance of this equipment should read and follow the instructions in this manual.**

**Operate the equipment only as stated in this manual. Incorrect use could cause damage to the equipment or personal injury.**

**It is the owner's responsibility to make certain that the operator reads and understands this manual before operating this equipment. It is also the owner's responsibility to make certain that the operator is a qualified and physically able individual, properly trained in the operation of this equipment.**

Specific safety warning decals are located on the equipment near the immediate areas of potential hazards. These decals should not be removed or obliterated. Replace them if they become non-readable.

- ALWAYS keep safety shields and covers in place, except for servicing.
- ALWAYS maintain a safe distance from people when operating.
- ALWAYS operate equipment in daylight or with adequate working lights.
- Follow daily and weekly checklists, making sure hoses are tightly secured and bolts are tightened.
- ALWAYS watch and avoid holes or deep depressions.
- ALWAYS wear adequate eye protection when servicing the hydraulic system and battery.
- NEVER operate a poorly maintained machine.
- NEVER allow persons to operate this machine without proper instruction.
- NEVER put hands or feet under any part of the machine while it is running.
- NEVER attempt to make any adjustments or repairs to the machine while running. Only Trained personnel should perform repairs or maintenance.
- NEVER work under the machine unless it is safely supported with stands, blocks or a hoist and blocks.
- NEVER touch hot parts of machine.

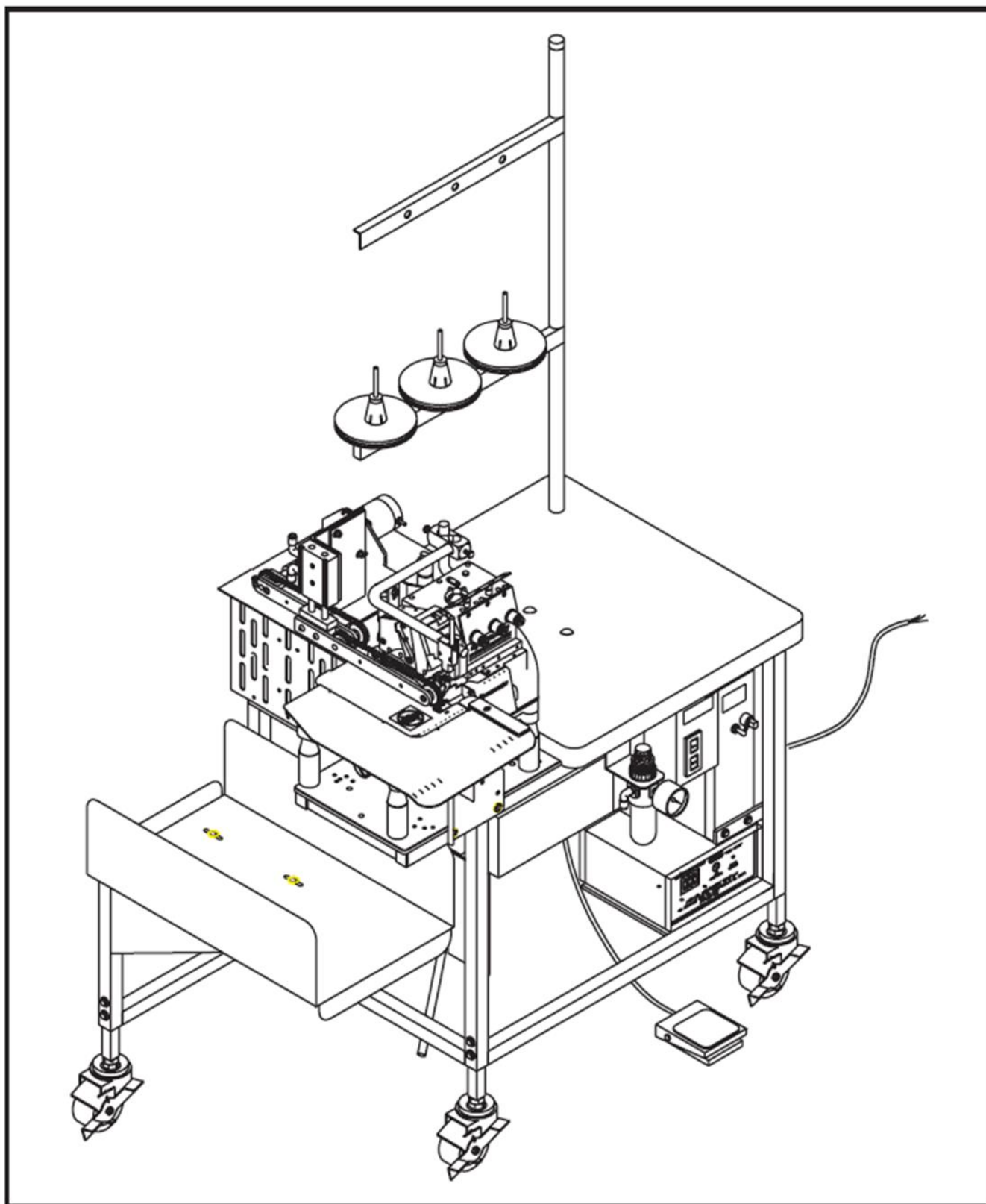

## Description

The AAP26M automated unit performs the closing operation on sleeves. The units contain Atlanta Attachment's patented back latch system along with various bundle table and stacking options. Within the AAC part number is a machine class code.

Two examples are: AAP26MG24 and AAP26MY23. G42 denotes Pegasus EX5204 and Y23 denote Yamato AZ8003-04DA.

See the table of contents for listing of accessories

### Codes and Machine Class

For easy reference Atlanta Attachment's Codes are as follow:

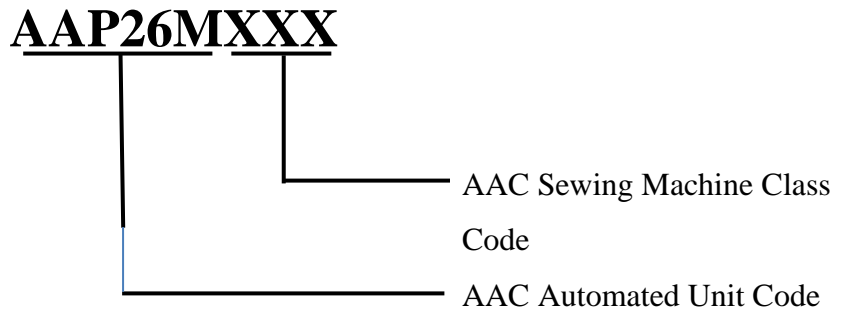

### Sewing Machine Codes

G24	PEGASUS EX5204
G29	PEGASUS S52-130
R63	RIMOLDI F27-00-1M-33
U89	UNION SPECIAL 39500XERF, 9M
Y23	YAMATO AZ8003H-04DA

## Installation

### 1. Power Connection.

Connect power cord (1) to correct power source. Most machines are 220vac, single phase. Be sure the green wire is connected to earth ground.

### 2. Air Supply

The main air regulator (2) should be set to 70-80 PSI. Air consumption is about 7 CFM.

### 3. Electric Eyes

Switch the AUTO/MANUAL toggle switch (13) to MANUAL and turn on power. Check both electric eyes for proper operation. The eye at the Handwheel (6) should be “light” when it is seeing the tape on the handwheel. The eye in front of the presser foot (7) should be “light” and pointed at the reflective tape in front of the presser foot. See page xxx for eye adjustment.

### 4. Thread Chopper

Momentarily press the CUT button and check operation of the thread chopper. The knife blades must close completely when the chopper is activated.

### 5. Stacker and Conveyor.

A. The skid plate (3) of the stacker should be perfectly level with the cloth plate (4) of the sewing machine. Loosen 4 screws (5) on the side of the stacker frame and level the skid plate as necessary.

B. The conveyor (8) should be parallel to the skid plate and should have about 1/32" (1mm) clearance above the skid plate when it is in the down position. Cover the eye (7) in front of the presser foot and momentarily press the foot switch (14). The conveyor will drop to the down position and stay there until the manual CUT button (12) is pressed. To adjust, loosen 2 screws (9). A thin piece of cardboard makes a good “gauge” to place between the conveyor and the skid plate while making this adjustment.

C. Press the JOG button (11) on the stepper motor control box and check the conveyor for smooth operation. If it does not run smoothly, turn off power and check the conveyor for mechanical problems.

D. Press and hold the CUT button. The stacker door (10) will open and stay open if you hold the button down. Release the button and the door will close. Adjust the flow controls on the cylinder for smooth operation.

### 6. Edge Guide

Set the edge guide on the cloth plate as required for proper trim-off.

### 7. Threading the Machine.

TURN OFF POWER. Thread the machine. Swing out the conveyor. Turn on power. Use the foot switch in MANUAL mode to run the sewing head. Use the CUT button to trim the chain. Swing in the conveyor.

### 8. Setting Conveyor Speed.

Switch to AUTO mode. Press Cut to reset the conveyor position up. Run a sleeve by placing it under the presser foot and covering the front eye. The sleeve should run straight back to the stacker. Adjust the thumbwheels (15) as necessary to synchronize the conveyor to the sewing head speed/stitch length so that the sleeve runs straight and the trim-off is uniform.

# Operation

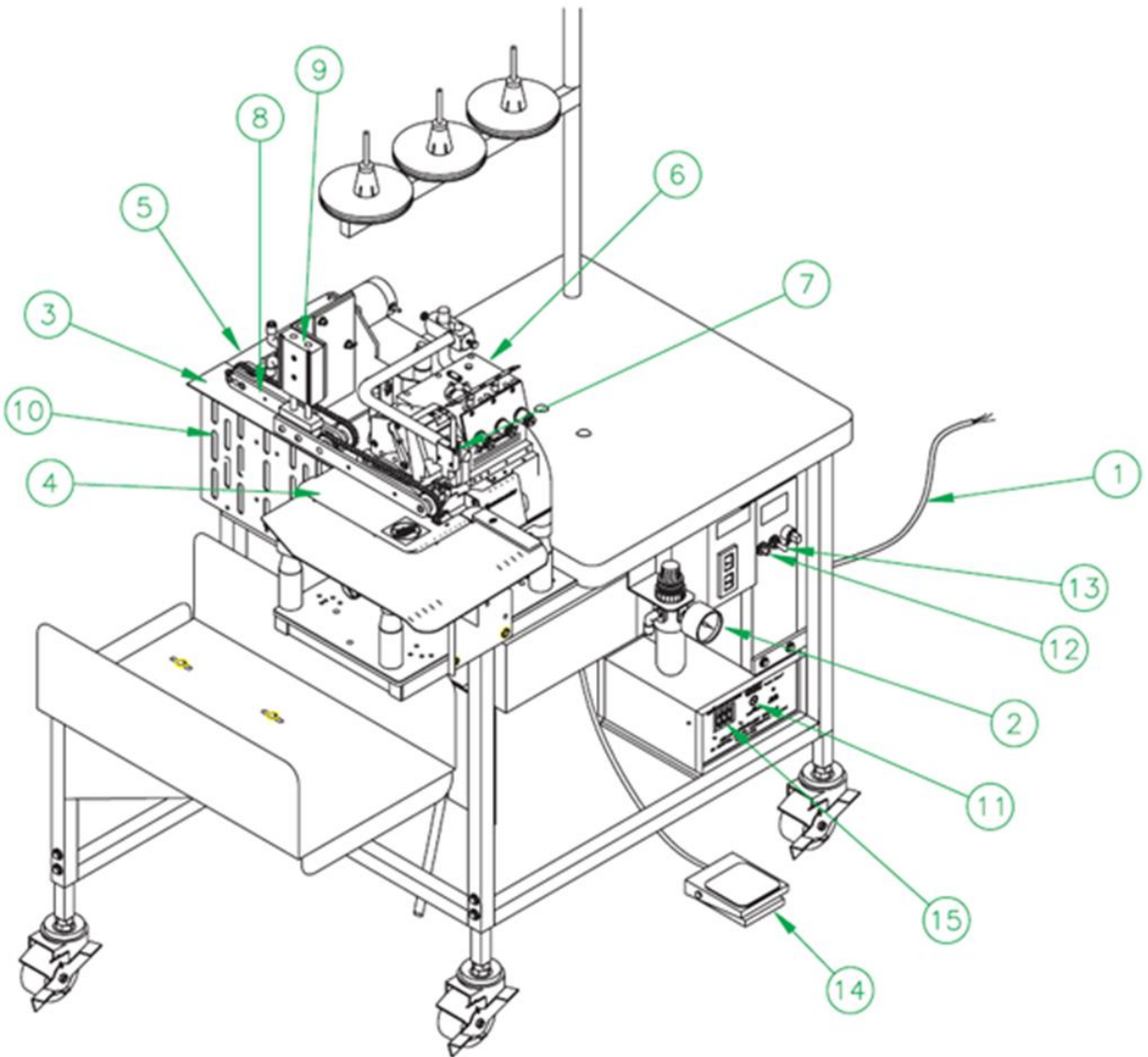

## 1. Main Control Box

A. CUT button (12). Activates the thread chopper. Hold down button to cycle the stacker door. Resets the machine to start of next cycle.

B. AUTO/MANUAL switch (13). In AUTO the machine starts when the front eye is covered.

C. In MANUAL the foot switch runs the sewing head. A sleeve can be sewn and stacked in MANUAL if the foot switch is held down until sewing is complete.

D. Fuse holder. Use 1/2 amp. slow blow type.

**E. Thumbwheels.**

#1 - L.E. Vacuum Stitches. Sets the on time for leading edge vacuum (times 8 stitches). This affects the quality of the BACKTACK. The vacuum must turn off before the front eye uncovers at the trailing edge of the sleeve.

#2 - Chain-off Stitches. Sets the length of the chain (times 2) at the trailing edge. The sewing head stops at the end of this count. Use together with thumbwheel #3 to ensure that the chain is pulled off the chaining tongue prior to cutting the chain.

#3 - Chain Pull-off Stop Delay. Sets the delay time from the head stopping until the chain cutter is activated. Adjust together with thumbwheel #2 to ensure the chain is pulled off the chaining tongue prior to cutting the chain. If this time is set to long, the sleeve will appear to stop moving during cutting, the conveyor may “stall”, and the stacking position will not be consistent.

#4 - Stack Position. Sets the stopping position of the conveyor prior to stacking. The time starts from the trailing edge of the sleeve uncovering the front eye.

**Illustration:**

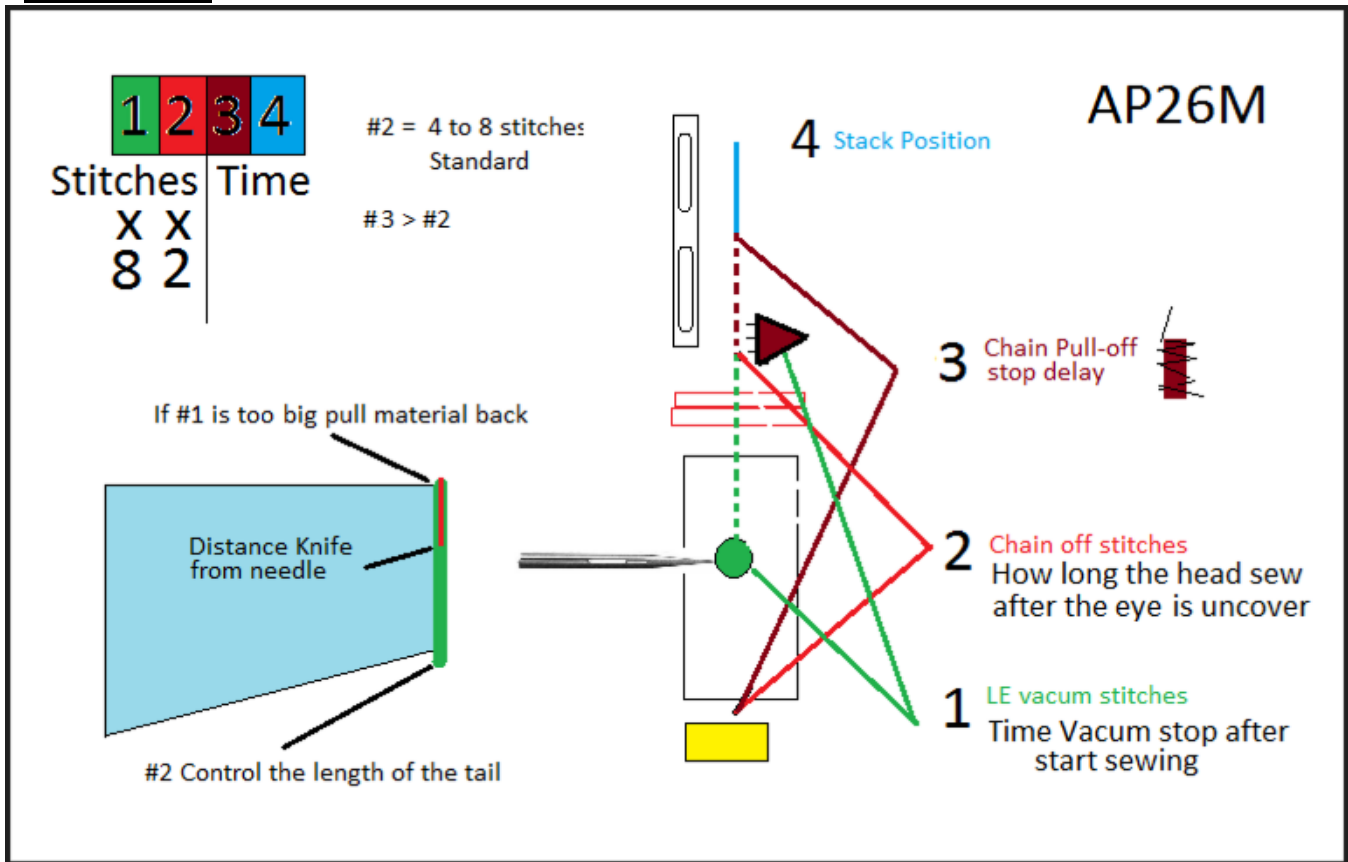

**2. Stepper Motor Control Box**

A. JOG button. Pressing this button will run the stepper motor in “jog” mode. This speed is adjustable by the small blue “pot” inside the box. This speed is usually set to about 25% faster than the conveyor runs while sewing. This extra speed helps to pull the chain off the chaining tongue prior to cutting.

B. Thumbwheels. Sets the synchronous speed of the conveyor while sewing. This speed is adjusted to match the stitch length and is proportional at all speeds.

C. Power On Lamp. Indicates power is on to the control box.

D. On/Off Switch. Located on the back side of the box above the power cord socket. Leave in on position. Always turn off “main” power switch before servicing this box.

### 3. 1975-512A Vacuum Ejector Assembly

**NOTE:**

The air supply to the ejector should be a minimum of four(4) SCFM at 80 PSI.

Trouble shooting: (Inconsistent back latch). (Pg.)

- A. Check air supply by observing pressure gauge while pressing cut button on front of the programmable controller. The pressure drop should be no more than 2-3 psi.
- B. Check for clog in vacuum ejector by removing assembly from the frame, noting how all connections were made. Remove item 3. From ejector and remove thread if necessary. Clean unit as thoroughly as possible and reinstall. Ensure all fittings are tight and do not leak, but do not over-tighten.
- C. Check connections from vacuum ejector to the throat plate to ensure there is a tight seal.

### 4. Electric Eye

To adjust the sensor first remove the transparent plastic cover from the end of the sensor. There are two adjusting screws under the cover. One screw is labeled “GAIN” and is used to set the sensitivity of the sensor. The second screw is labeled “DO & LO”. DO NOT adjust. ADJUSTMENT: With the eye of the sensor pointing at the center of the reflective tape, turn the “GAIN” screw counterclockwise until the red L.E.D. indicator is not on. Then turn the “GAIN” screw clockwise until the red L.E.D. Indicator comes on. Then turn the “GAIN” screw one full turn clockwise. The L.E.D. indicator should be blinking slowly. Cover the reflective tape and the L.E.D. indicator should go off.

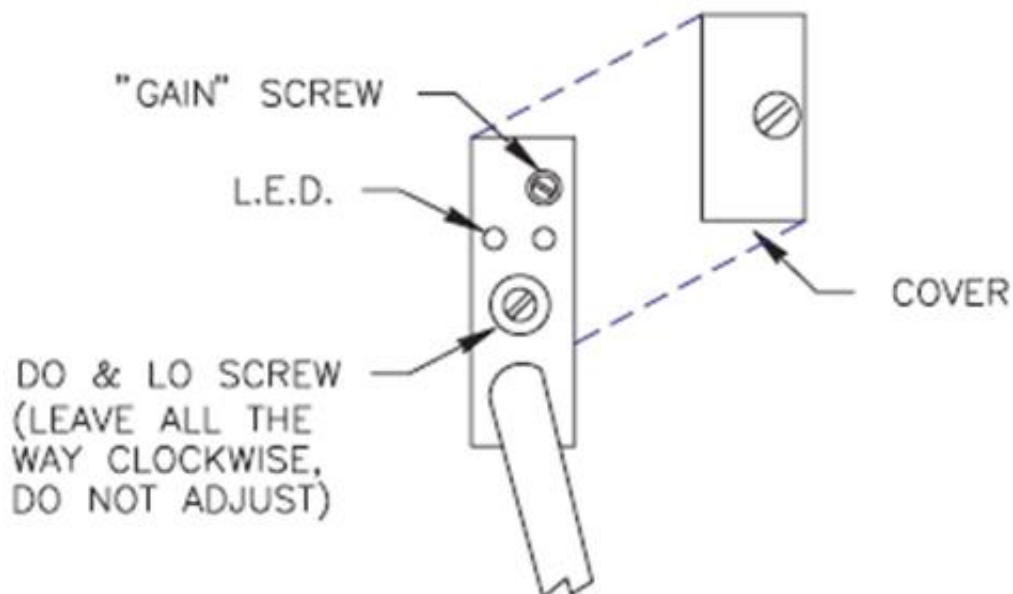

## AP26M Trouble shooting

### 1. Machine will not run at all.

Check “Lights” on electric eyes. If eyes are lit you have power. If not, check control box power supply.

### 2. Conveyor will not run while sewing but does run in jog cycle.

- A. Faulty sync cable. Inspect cable.
- B. Faulty sewing motor. Test run with side lever.
- C. Faulty stepping motor control box. Replace.

### 3. Conveyor runs while sewing but does not jog to stack position.

- A. Faulty Aux cable. Inspect cable.
- B. L.E. Vacuum time set too high. Reduce time.
- C. Faulty stepping motor control box. Replace.

### 4. Presser foot and the front of the conveyor drop very slowly.

- A. Disconnect air lines at cylinder, cycle the foot lift, and check air flow. If flow is low replace defective solenoid.
- B. If air flow is good, replace defective flow controls.
- C. Check the normally open output from the solenoid valve while the power is on. Replace if leaking air.

### 5. Presser foot and front conveyor will not drop.

- A. Check the normally open output from the solenoid valve while the power is on.
- B. Replace if leaking air.
- C. Check solenoid valve electrical connection. Manually operate solenoid valve with built in manual button.

### 6. Machine will not sew when start eye is covered in AUTO.

- A. Faulty sewing motor. Replace.
- B. Machine is in MANUAL. Check faulty AUTO/MANUAL switch.
- C. Machine will not sew when motor treadle lever is pressed. Replace defective motor.
- D. Cable between motor and control box defective.

### 7. Conveyor runs as soon as power is turned on but sewing head is not running.

- A. Disconnect AUX cable on stepper control box. If conveyor stops then check 24v power supply in control box.
- B. If conveyor continues to run then replace stepper control box.

### 8. Machine runs-away when power is turned on in AUTO.

- A. Be sure power is turned on to all control boxes.
- B. Check front sew eye operation. Adjust or replace.
- C. Foot switch defective

**9. Stepping motor will not run in automatic, jog, or runs backwards**

- A. Check socket at stepping motor for broken or bent pins.
- B. Check stepping motor cable and plugs for loose connections.
- C. Check pulleys and belts.
- D. With power turned off and the stepping motor still plugged in, turn the stepping motor shaft by hand. Moderate resistance to turning indicates a defective stepper motor control box or shorted cable. Make this test again with the other end of the cable disconnected at the stepper motor control box to see if it is the box or the cable

**10. Stacker door does not open all the way.**

- A. Adjust or replace defective flow controls.
- B. Manually cycle solenoid and check operation. Backtack problems

**11. Backtack has a knot on the leading edge of sleeve.**

- A. Insufficient vacuum for proper backtack. Check air pressure. Should be 70 psi while sewing. Check for clogged tube on throat plate, air line or vacuum generator.
- B. Chain-off stitch count too long causing buildup of chain on chaining finger.
- C. Stop delay too short causing buildup of chain on
- D. Burr on end of chaining finger tube.
- E. Sewing machine not stopping in correct position.
- F. Leading edge vacuum stitch count too short.
- G. Improper adjustment of needle threads take-up.

**12. Trailing edge chain too long.**

- A. Chain-off stitch count too long.
- B. Stop delay too long.
- C. Electric eye not reading reflective tape consistently.

**13. Trailing edge chain too short.**

- A. Chain-off stitch count too short.
- B. Stop delay too short.
- C. Conveyor not pulling sleeve properly.
- D. Sleeve not chaining off out from under presser foot.

**14. Breaks thread during chain-off/cut cycle.**

- A. Chain-off stitch count too short. Cutter cutting on sleeve.
- B. Conveyor running too fast in jog mode.
- C. Chain pull-off stop delay too long pulling the thread out of the needle and loopers.

**15. Cutter not cutting all three threads of chain.**

- A. Chain-off stitch count too short. Cutter cutting on sleeve causing threads to go behind the Cutter.
- B. Stop delay too long. Cutter missing some threads.
- C. Conveyor running too fast in jog mode.

**16. Thread chain is blown out of tube at end of cut/back tack cycle.**

- A. Defective pneumatic valve on vacuum generator.
- B. Clogged exhaust port on vacuum generator.
- C. Missing plug on pneumatic valve on vacuum generator.

## Routine Maintenance

### 1. Daily Maintenance:

- A. Clean lint from sewing motor and conveyor.
- B. Use blower gun to clean sewing head and table top.
- C. Wipe off lenses on electric eyes with soft cloth.
- D. Drain water trap on air regulator.

### 2. Weekly Maintenance:

- A. Using SF Oil for high-speed sewing or equivalent, place 3 drops of oil on the needle bar above and below the sleeve.
- B. Using SF Oil for high-speed sewing or equivalent, place 3 drops of oil on the looper bar.
- C. Check level of thread lubricant reservoirs, fill with silicone oil as necessary.
- D. Clean and lubricate u-joints on conveyor drive.

### 3. Monthly Maintenance:

- A. Check all belts for wear and adjustment.
- B. Check all set screws on drive component.
- C. Check and re-adjust and cutter blade up and down position
- D. Check all cylinders and flow control adjustments.

### 4. 90 day or 3 months Maintenance:

- A. Change oil and filter on sewing head.

### 5. Special Note

- A. For the sewing head to have a long life, the manufacturer recommends frequent oil changes:
  - After the first 250 hours of operation the oil should be removed and replaced completely.
  - After that, the oil should be changed 2 or 3 times a year for one(1) shift operations
  - If the head is subjected to multiple shifts per day, oil change frequency should be increased to 30 or 60 day intervals

## Thread Cutter Adjustment, UP-Position Details

### Upper “Movable” Blade..Up-Position

1. Set air pressure on chain cutter air cylinder to operating pressure.  
Normal range is 40 – 60 psi maximum

2. Air cylinder shaft must be extended, with clevis and linkage tight..



3. Move cylinder pivot nut, up or down to adjust position.  
\*Retighten Clevis and linkage after adjustment. \*



**\*Correct up-position\***

4. Rear of blade should have adequate clearance, without hitting any surfaces, such as casting or needle linkage.



## Thread Cutter Adjustment, Down-Position Details

### Upper "Movable" Blade..Down-Position

5. Move clamp collar up or down cylinder shaft to position Movable- blade in maximum down position.



### Correct down-position

6. Maximum down position is measured from cutting edge of movable-blade to below cutting edge of stationary-blade

\*It should never hit the lower surface of bed plate.\*  
Normal setting is 3/32" or 2.36mm below cutting edge of stationary-blade



### Recommendations:

Set-up these procedures in preventative maintenance schedule and check setting weekly, monthly or after a set number of cycles.

Failure to correctly set stroke or position of movable-blade will result:

- A. In damage to the cutting edges of one or both blades
- B. Bend movable-blade shaft
- C. Broken cutter body, from excess range or movement of movable blade

## Efka Motor Parameter Settings,

26M-PAR			
Before Programming, Perform a Master Reset of Parameters (See Below)			
PARAMETER	RANGE	VALUE	DESCRIPTION
290		7	Mode of operation (overedge). MUST SET THIS PARAMETER FIRST!
026		0	Standard treadle
111	200-9900 rpm	6800	Maximum speed when "129" is 0, 1, or 2.
161	0-1	1-CCW	Motor rotation
204		100	Foot lift modulation
270	0-5	1	External handwheel sensor configuration.
272	0200-2550	1000	Drive ratio between motor pulley and handwheel pulley. If handwheel pulley is smaller than motor pulley, increase this value to slow down sewing head until measured speed matches speed set with parameter 111. (For Yamato and Pegasus, setting should be 100; for Rimoldi, setting should be 124)
362	0-1	1	Position sensor voltage: 0 = 5V, 1 = 15V
401		0-1	Change from 0 to 1 to save settings
436		0	Use code "5913". This disables an input that was causing box to reset itself.
Front panel LED's:		Programming Instructions:	
LED 1:	Off	1. Power on holding down the "P" button till "COD" is displayed.	
LED 2:	Off	2. Press ">>" once and enter the number "5913"	
LED 3:	Off	3. Press "E" once and "2.0.0." is displayed this is a parameter	
LED 4:	Off	4. Proceed to the parameter to be changed and press "E"	
LED 5:	Off	5. The value now shows in the screen, adjust to desired value.	
LED 6:	Off	6. Press "E" to enter value and continue with parameter setting.	
LED 7:	Off, Stop at needle down.	7. Repeat for other parameters, press "P" once when complete.	
LED 8:	On, Stop at needle up.	8. Run sewing head to save parameters before powering down	

<b>To Perform Master Reset of Parameters:</b>			
1. Go to manual and lower presser foot.			
2. Power off-on Efka box holding down the "P" button till "COD" is displayed.			
3. Press ">>" once and enter the number "5913"			
4. Press "E" twice and "093" is displayed.			
5. Press "+" once, "094" is displayed.			
6. Press "P" to exit programming mode with all default values.			
7. Reset machine.			

## Part List Directions

**The following pages contain the appropriate assembly drawings for this unit.  
Las páginas siguientes contienen los dibujos de los ensambles que hacen parte de esta unidad.**

Below is a brief description of the Atlanta Attachment parts list and how to use it.  
Debajo hay una descripción de la lista de partes de Atlanta Attachment y cómo usarla.

NO.	QTY	PART #	DESCRIPTION	Page20
-----	-----	--------	-------------	--------

1	1	010-047	Belt Idler Assy	
---	---	---------	-----------------	--

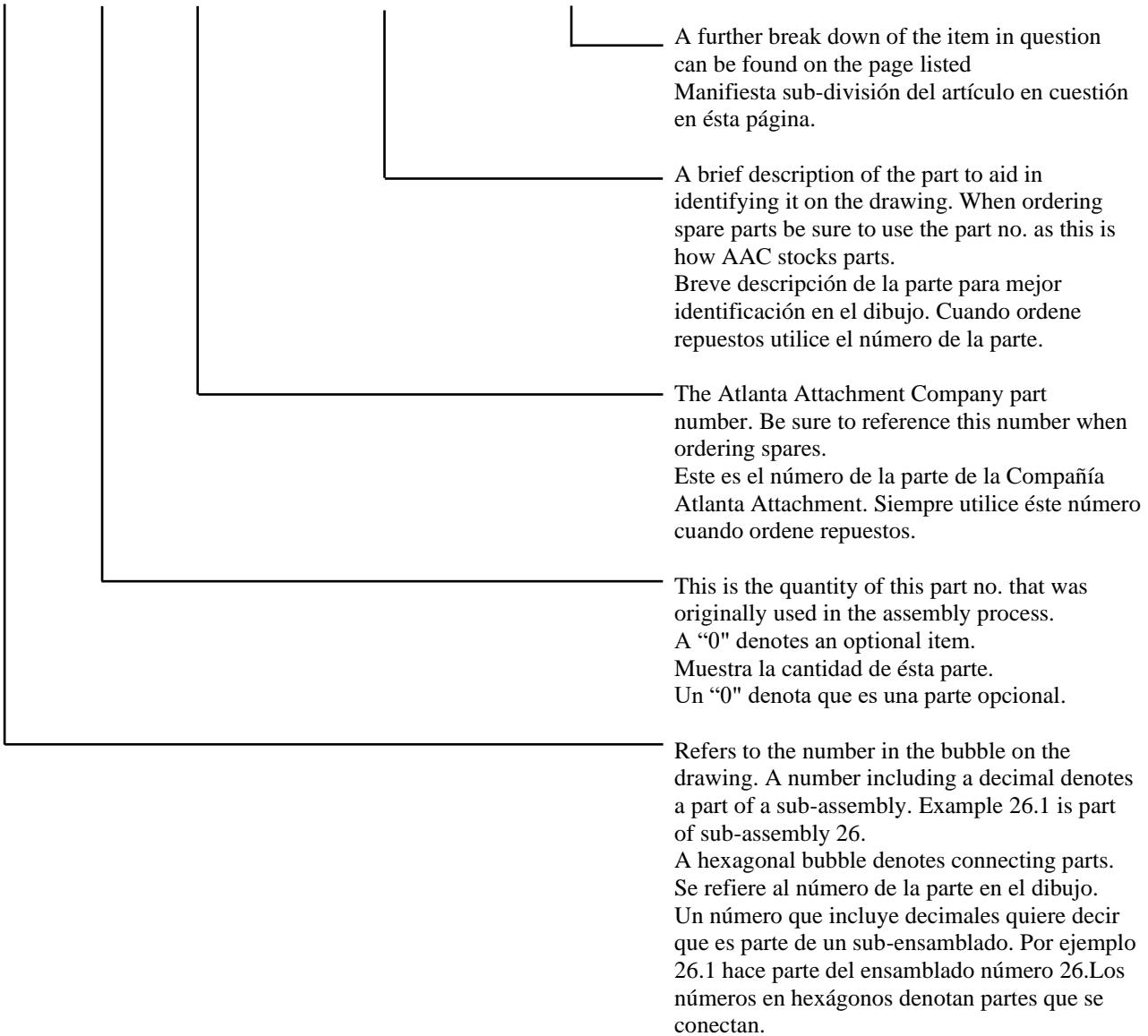

A further break down of the item in question can be found on the page listed  
Manifiesta sub-división del artículo en cuestión en ésta página.

A brief description of the part to aid in identifying it on the drawing. When ordering spare parts be sure to use the part no. as this is how AAC stocks parts.  
Breve descripción de la parte para mejor identificación en el dibujo. Cuando ordene repuestos utilice el número de la parte.

The Atlanta Attachment Company part number. Be sure to reference this number when ordering spares.  
Este es el número de la parte de la Compañía Atlanta Attachment. Siempre utilice éste número cuando ordene repuestos.

This is the quantity of this part no. that was originally used in the assembly process.  
A "0" denotes an optional item.  
Muestra la cantidad de ésta parte.  
Un "0" denota que es una parte opcional.

Refers to the number in the bubble on the drawing. A number including a decimal denotes a part of a sub-assembly. Example 26.1 is part of sub-assembly 26.  
A hexagonal bubble denotes connecting parts.  
Se refiere al número de la parte en el dibujo.  
Un número que incluye decimales quiere decir que es parte de un sub-ensamblado. Por ejemplo 26.1 hace parte del ensamblado número 26. Los números en hexágonos denotan partes que se conectan.

## Assembly Drawings & Parts Lists

The materials contained herein are confidential and proprietary information of Atlanta Attachment Company. In addition to any confidentiality and non-disclosure obligations that currently exist between you and Atlanta Attachment Company, your use of these materials serves as an acknowledgment of the confidential and proprietary nature of these materials and your duty not to make any unauthorized use or disclosure of these materials.



### **One-Stop Shopping**

For Expendable Replacement Parts for AAC & Other Bedding Equipment Suppliers

Toll Free: **1-866-885-5100**

[www.atlantapartsdepot.com](http://www.atlantapartsdepot.com) • [sales@atlantapartsdepot.com](mailto:sales@atlantapartsdepot.com)

# AAP26MG24 Short Sleeve Closer, Pegasus EX5204, Pana

AAC Drawing Number 192043C Rev 1

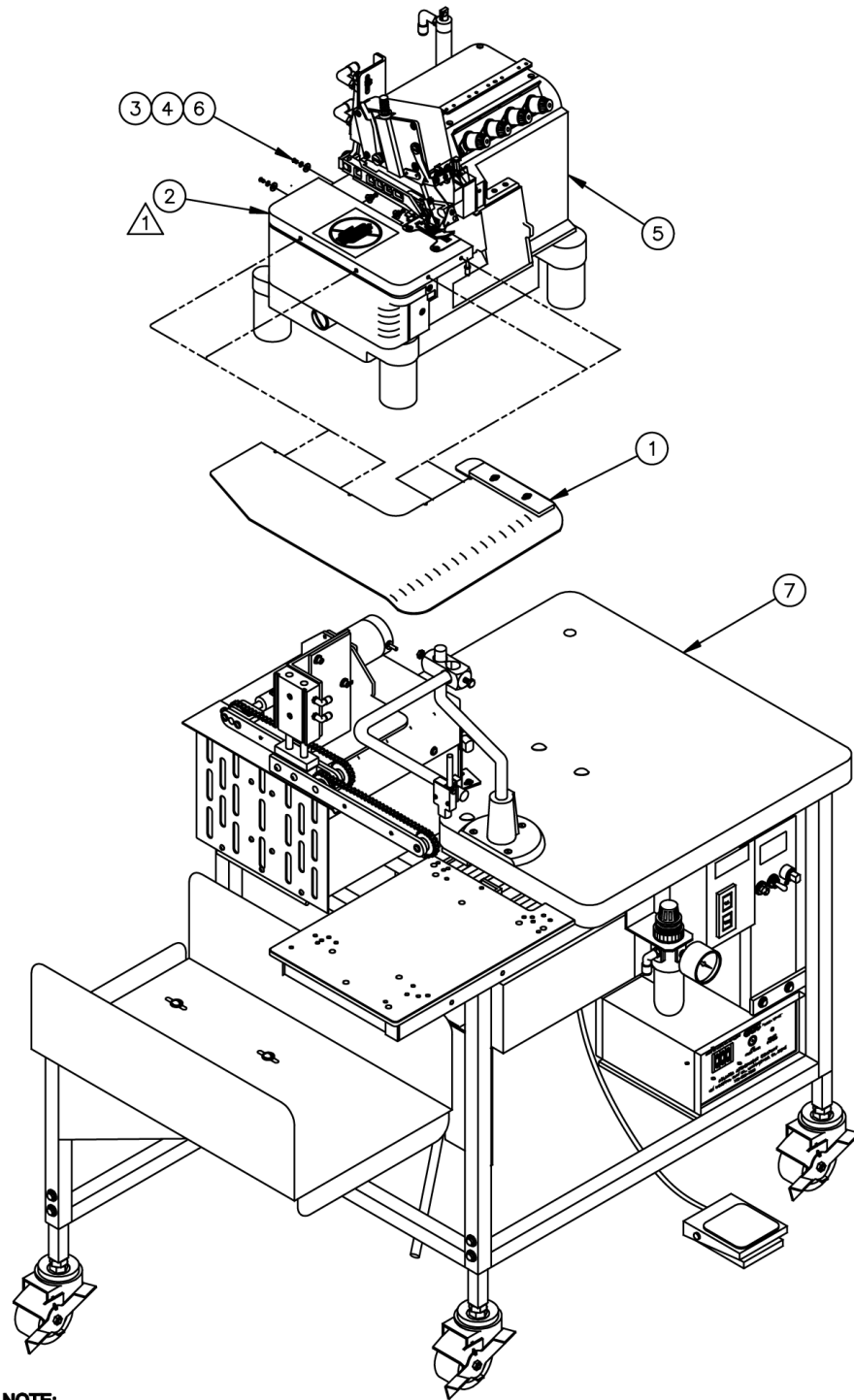

**NOTE:**

△ **IF THE CLOTH PLATE OF YOUR MACHINE HAS SQUARE EDGES, (INSTEAD OF ANGLED EDGES), THE CLOTH PLATE ASSEMBLY PART NUMBER IS 26097C**

NO.	QTY	PART #	DESCRIPTION	NO.	QTY	PART #	DESCRIPTION
1	1	26097C	Cloth Plate Assy	5	1	AP-26M-11	Sewing Head Details
2	1	?	Cloth Plate Mod.	6	4	WWSI6	Int Tooth Washer
3	4	SSTS85024	Scr, Tr SI 6-40x3/8	7	1	26M-G	Table Assy
4	4	WWB5/32ID	Brass Washer	8	AR	26M-1120	Label, Tag

# AAP26MY23 Auto Short Closer, Yamato

AAC Drawing Number 191933C Rev 6

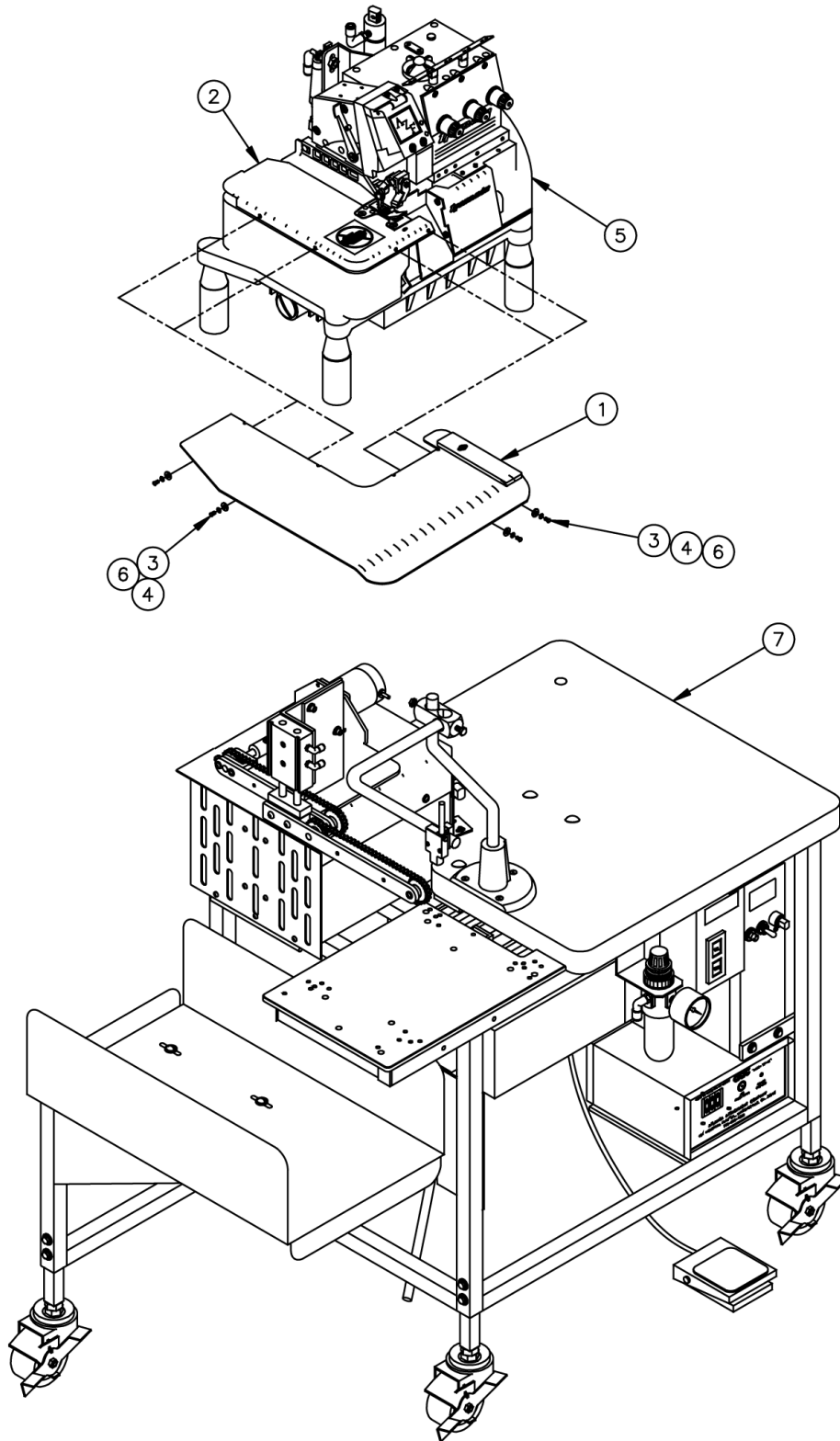

NO.	QTY	PART #	DESCRIPTION	NO.	QTY	PART #	DESCRIPTION
1	1	26097C	Cloth Plate Assy	5	1	AP-26M-06	Sewing Head Details
2	1	26347B	Cloth Plate	6	4	WWSI6	Int Tooth Washer
3	4	SSTS85024	Scr, Tr SI 6-40x3/8	7	1	26M-G	Table Assy
4	4	WWB5/32ID	Brass Washer	8	AR	26M-1120	Label, Tag

# AAP26MY52 Auto Short Sleeve Closer, Yamato AZ8003G-04DA

AAC Drawing Number 192328C Rev 0

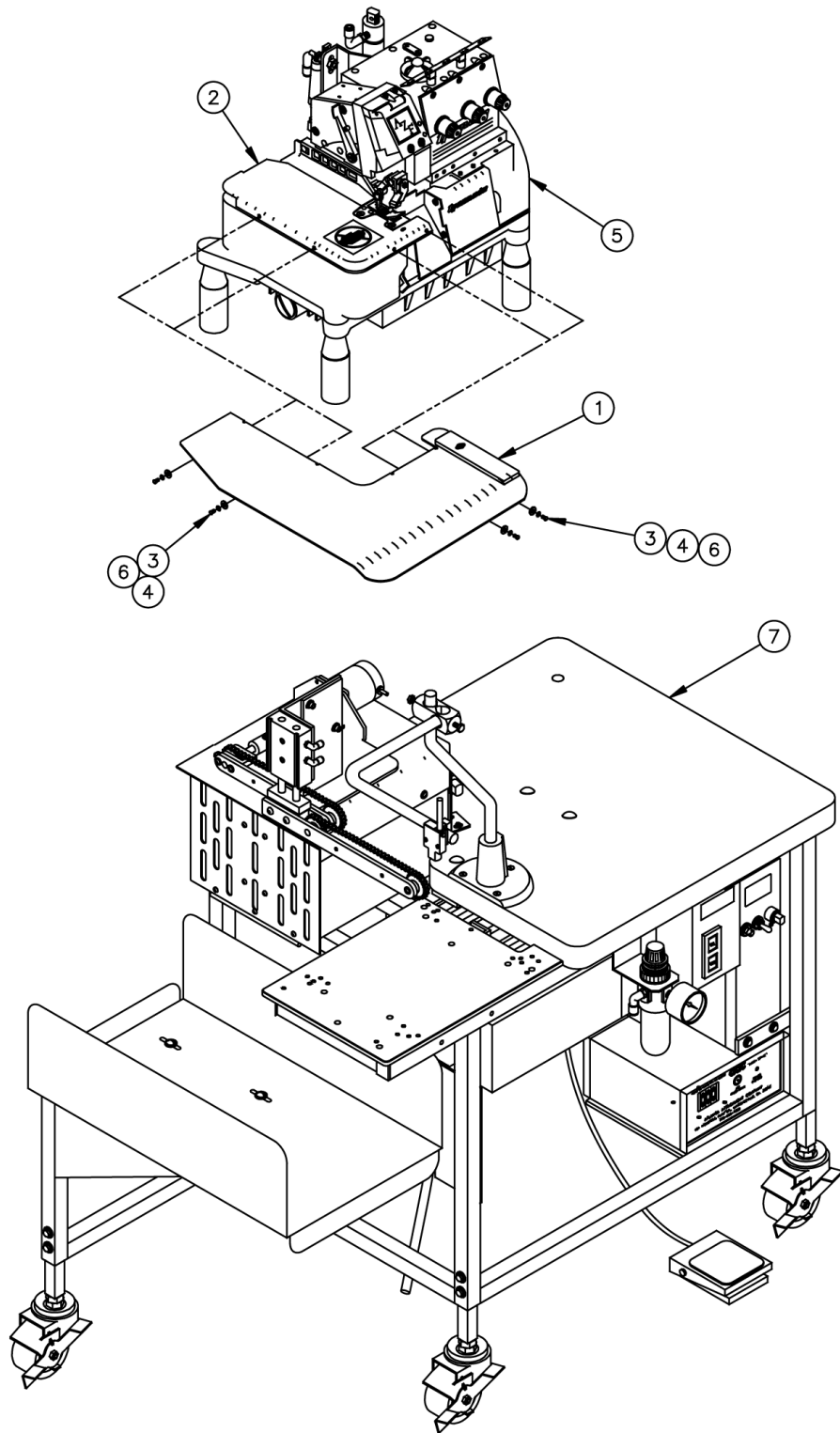

NO.	QTY	PART #	DESCRIPTION	NO.	QTY	PART #	DESCRIPTION
1	1	26097C	Cloth Plate Assy	6	4	WWSI6	Int Tooth Washer
2	1	26347B	Cloth Plate	7	1	26M-G	Table Assy
3	4	SSTS85024	Scr.Tr SI 6-40x3/8	8	AR	26M-1120	Label, Tag
4	4	WWB5/32ID	Brass Washer	9	AR	ZZ26M	Tech Manual
5	1	AP-26M-23	Sewing Head Details	10	10	SNB27-11	Needle

# AAP26MEG24 Auto Shirt Closer, Efka

AAC Drawing Number 192871C Rev 1

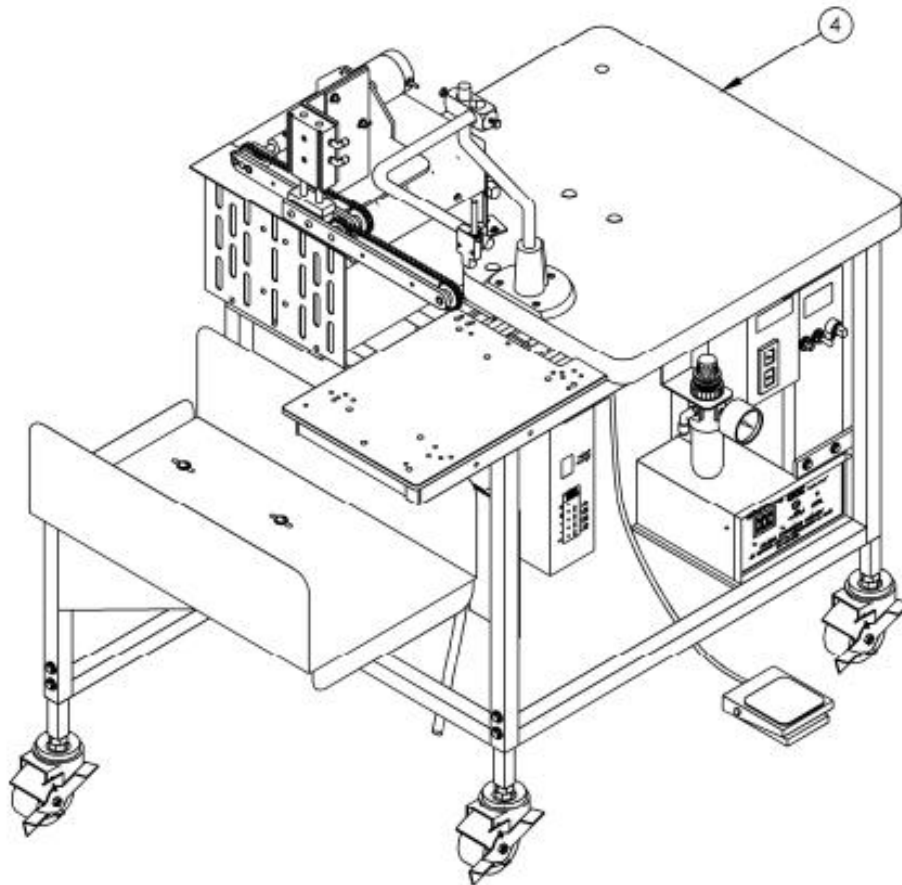
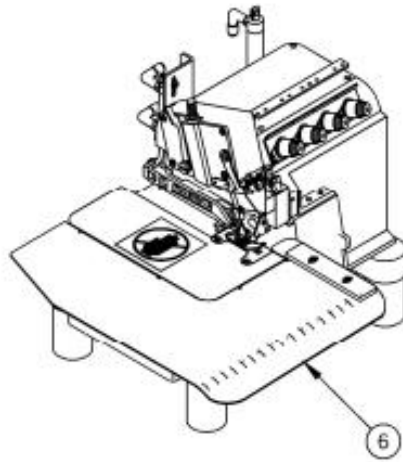

NO.	QTY	PART #	DESCRIPTION	NO.	QTY	PART #	DESCRIPTION
1	AR	ZZ26M	Manual	5	AR	26M-PD	Pneumatic Diagram
2	AR	26M-1120	Label, Tag	6	1	AP-26M-11	Sewing Head Details
3	1	26ME-WD	Wiring Diagram	7	AR	26M-PAR	Parameter Settings
4	1	26ME-G	Table Assy				

## AAP26MEG27P Auto Shirt Closer, PLC with Efka Motor

AAC Drawing Number 9008775 Rev 0

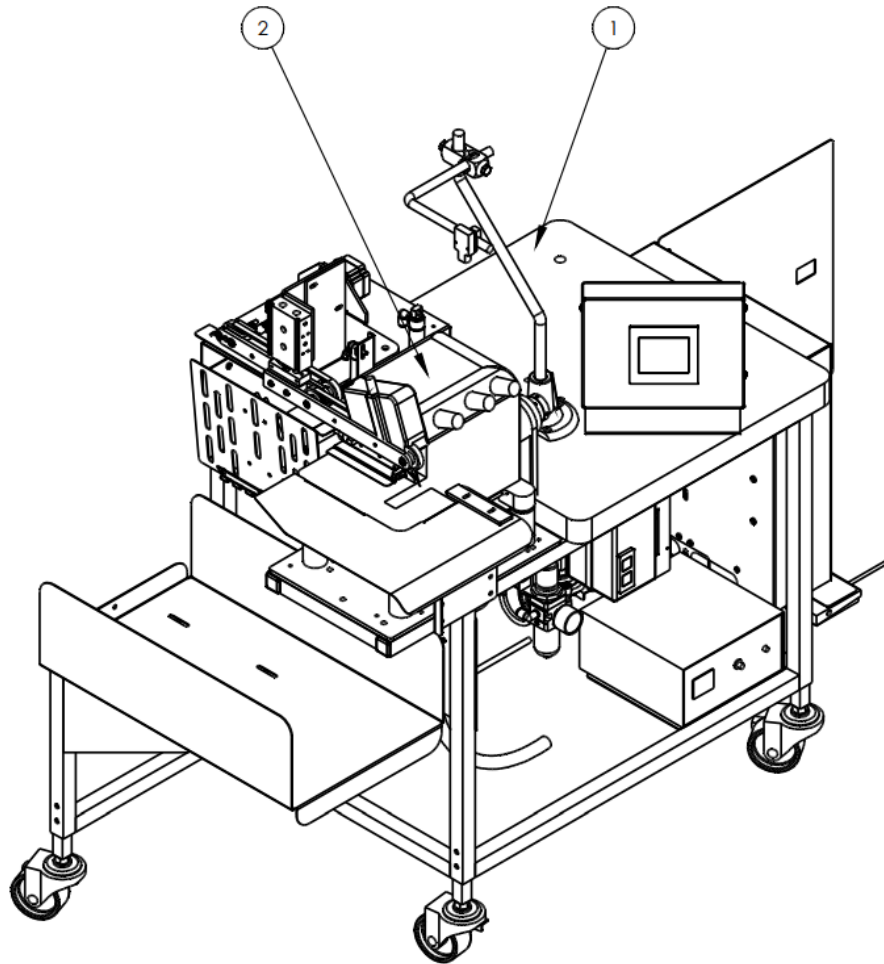

ITEM NO.	QTY.	PART NUMBER	DESCRIPTION
1	1	26ME-GP	TABLE ASSY GENERIC,EFKA, PLC
2	1	AP-26M-13	SEWING HEAD DETAIL
3	1	26M-PAR	PARAMETER SETTING EFKA
4	1	26M-PD	DIAGRAM, PNEUMATIC FOR AP25M
5	1	AP26MPLC-WD1	WIRING DIA., PLC, AP26M

# 26M-G Table Assembly

AAC Drawing Number 191964C Rev 3

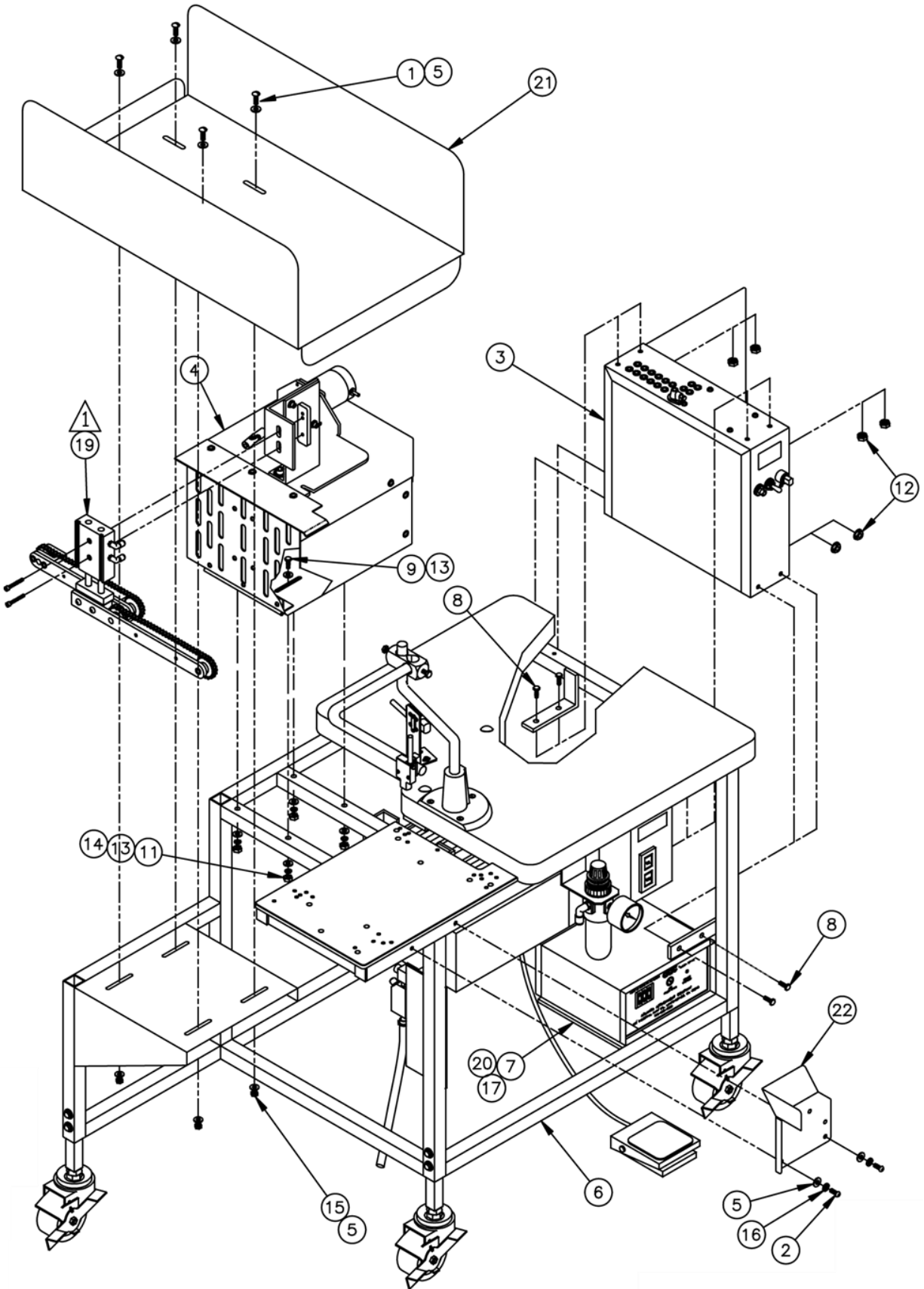

26M-G Table Assembly

NO.	QTY	PART #	DESCRIPTION
1	4	SSTS98040	Scr, Tr Hd sl 10-32x5/8
2	2	SSBC98024	Scr, But Cp 10-32x3/8
3	1	26M-500	Prog Controller
4	1	AP-26M-02	Flip Stacker Assy
5	10	WWFS10	SAE Flat Washer
6	1	AP-26MGP	Console, Generic
7	1	AP-28-600B	Control Box
8	8	SSHC01040	Scr, Hx Cp 1/4-20x5/8
9	4	SSHC01112	Scr, Hx Cp 1/4-20x1-3/4
10	AR	26M-PD	Pneumatic Diagram
11	4	NNH1/4-20	Hex Nut
12	8	NNK1/4-20	Kep Nut
13	8	WWFS1/4	SAE Flat Washer
14	4	WWL1/4	Lock Washer
15	4	NNK10-32	Kep Nut
16	2	WWSE10	Ext Tooth Washer
17	4	WWSI6	Int Tooth Washer
18	AR	26M-WD	Wiring Diagram
19	1	AP-26M-03	Conveyor Assy
20	4	SSPS80024	Scr, Pn Hd sl 6-40x3/8
21	1	26M-1001	Stacker Tray
22	1	26M-1003	Brkt, Chip Chute

# 26ME-G Table Assembly, Efka

AAC Drawing Number 192870C Rev 0

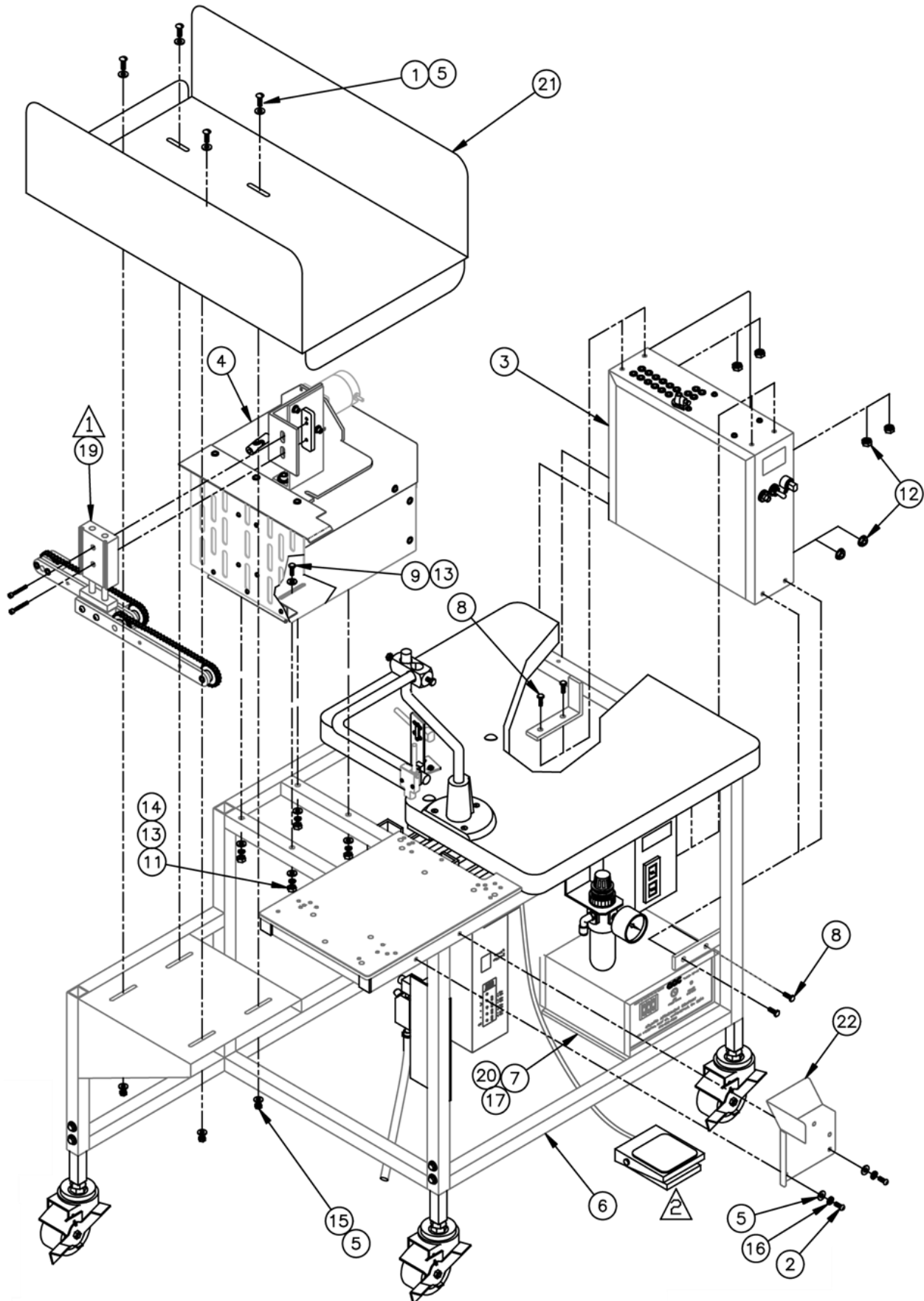

26ME-G Table Assembly

<b>NO.</b>	<b>QTY</b>	<b>PART #</b>	<b>DESCRIPTION</b>
1	4	SSTS98040	Screw, Truss Head
2	2	SSBC98024	Screw, Button Cap
3	1	26ME-500	Prog. Controller
4	1	AP-26M-02	Flip Stacker Assy
5	10	WWFS10	Flat Washer
6	1	AP-26MEG	Generic Console
7	1	AP-28-600B	Control Box
8	8	SSHC01040	Screw, Hex Cap
9	4	SSHC01112	Screw, Hex Cap
10	AR	26M-PD	Pneumatic Diagram
11	4	NNH1/4-20	Hex Nut
12	8	NNK1/4-20	Kep Nut
13	8	WWFS1/4	Flat Washer
14	4	WWL1/4	Lock Washer
15	4	NNK10-32	Kep Nut
16	2	WWSE10	External Tooth Washer
17	4	WWSI6	Internal Tooth Washer
18	AR	26ME-WD	Wiring Diagram
19	1	AP-26M-03	Conveyor Assy
20	4	SSPS80024	Screw, Pan Head
21	1	26M-1001	Stacker Tray
22	1	26M-1003	Brkt, Chip Chute

# 26ME-GP Table Assembly, PLC with Efka Motor

AAC Drawing Number 9008774 Rev 2

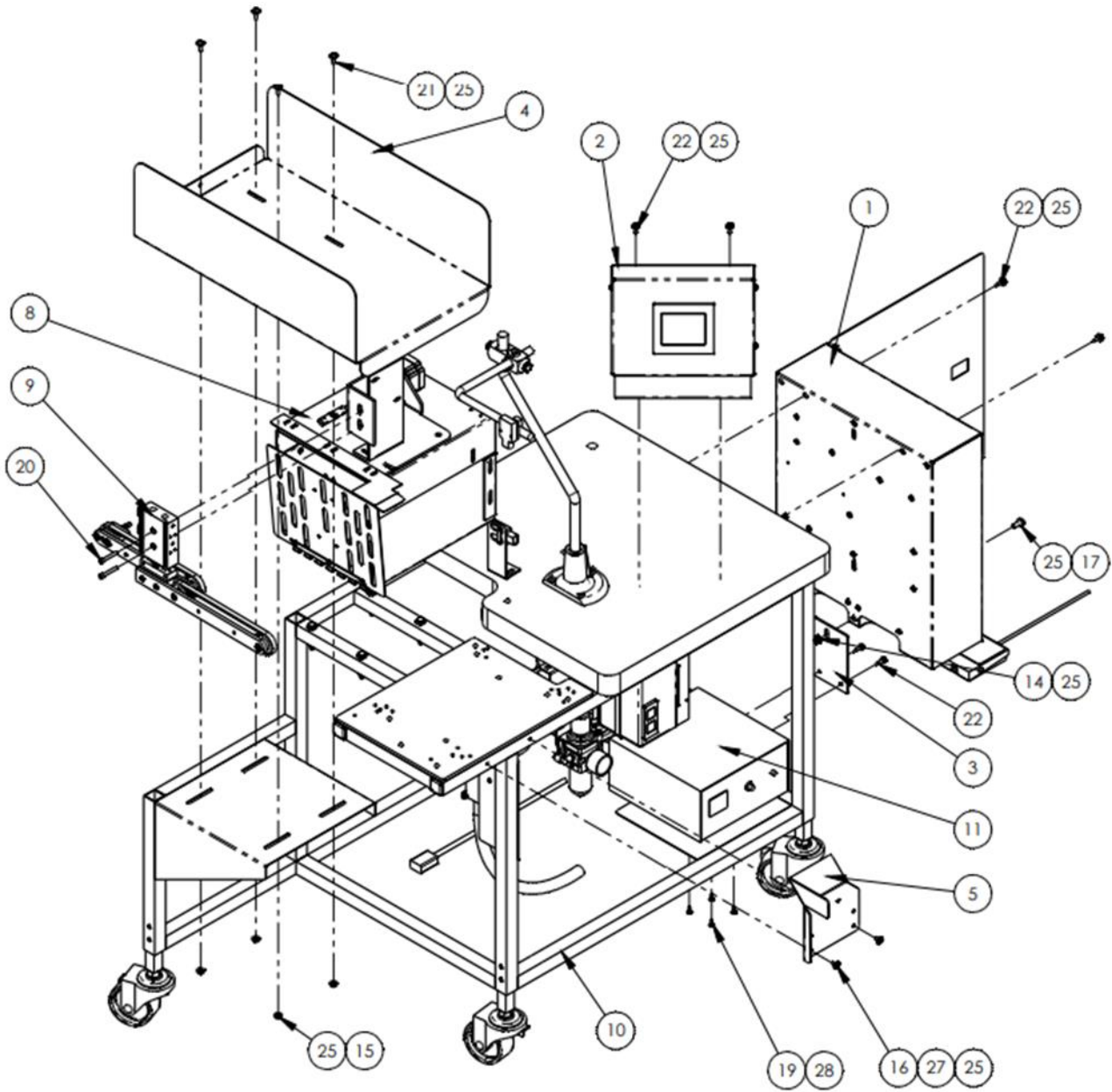

26ME-GP parts list

ITEM NO.	QTY.	PART NUMBER	DESCRIPTION
1	1	1336021	CONTROL BOX ASSY, PLC,AP26M
2	1	1336025	PLC SCREEN ASSY, W 3.5 COLOR
3	1	2600001	BRACKET, CABINET LOWER SUPPORT
4	1	26M-1001	TRAY, STACKER, AP26M
5	1	26M-1003	BRKT, CHIP CHUTE
6	1	26M-PD	DIAGRAM, PNEUMATIC FOR AP25M
7	1	26ME-LAB	LABEL PACKAGE 26ME-G
8	1	AP-26M-02	FLIP STACK ASSEMBLY AAP26M
9	1	AP-26M-03	CONVEYOR ASSEMBLY
10	1	AP-26MEG	CONSOLE, GENERIC, EFKA AAP6ME
11	1	AP-28-600B	CONT BOX,STACKABLE METERING
12	1	AP26MPLC-WD1	WIRING DIA., PLC, AP26M
13	4	NNH1/4-20	NUT,HEX,1/4-20
14	1	NNK1/4-20	NUT,KEP,1/4-20
15	4	NNK10-32S	KEP NUT, 10-32,S/S
16	2	SSBC98024	10-32 X 3/8 BUTTON CAP SC
17	1	SSHCO1040	1/4-20 X 5/8 HHCS
18	4	SSHCO1112	1/4-20 X 1-3/4 HHCS
19	4	SSPS80024	#6-32 X 3/8 LG PAN HD
20	2	SSSC98080	10-32 X 1-1/4 SOC CAP
21	4	SSTS98040	10-32 X 5/8,TRUSS HD
22	6	SSZH#10048	SCREW,SHT.METAL HEX 10
23	4	WWFS1/4	WASHER,FLAT,SAE,1/4
24	4	WWFS1/4	WASHER,FLAT,SAE,1/4
25	16	WWFS10	WASHER, FLAT, #10, SAE
26	4	WWL1/4	WASHER,LOCK, 1/4
27	2	WWSE10	WASHER,EXT. TOOTH,10 LOCK
28	4	WWSI6	WASHER,INT. TOOTH

# 1336025 PLC Screen Assembly

AAC Drawing Number 1336025 Rev 1

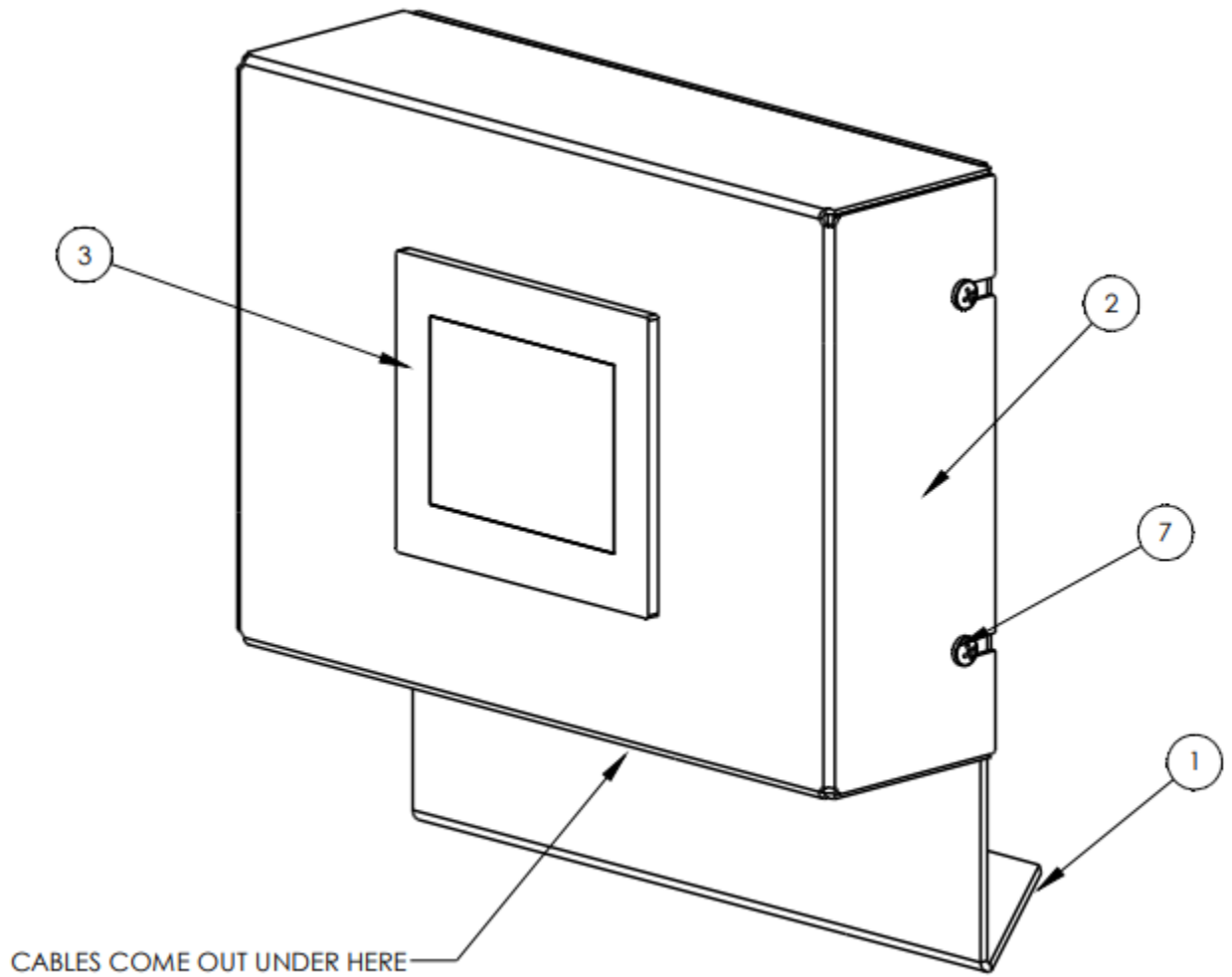

ITEM NO.	Hardware Shown/QTY.	PART NUMBER	DESCRIPTION
1	1	1336009	PLC SCREEN BACK/MOUNT
2	1	1336024	PLC SCREEN PANEL, 3.5 COLOR
3	1	EEAIG03TQ13DE	TOUCHSCREEN, 3.5" COLOR, RS232C
4	10 FT	FF36F1086W	CABLE, 4 CON, 20GA
5	6.5 FT	FF1173C	CABLE, 3 COND, 22 AWG
6	1	MM9307K69	GROMMET,5/8,1.125,.125GV
7	3	SSPP90024	8-32X3/8 PAN PHLPS

# AP-26MGP Console, Generic, Panasonic

AAC Drawing Number 191932C Rev 5

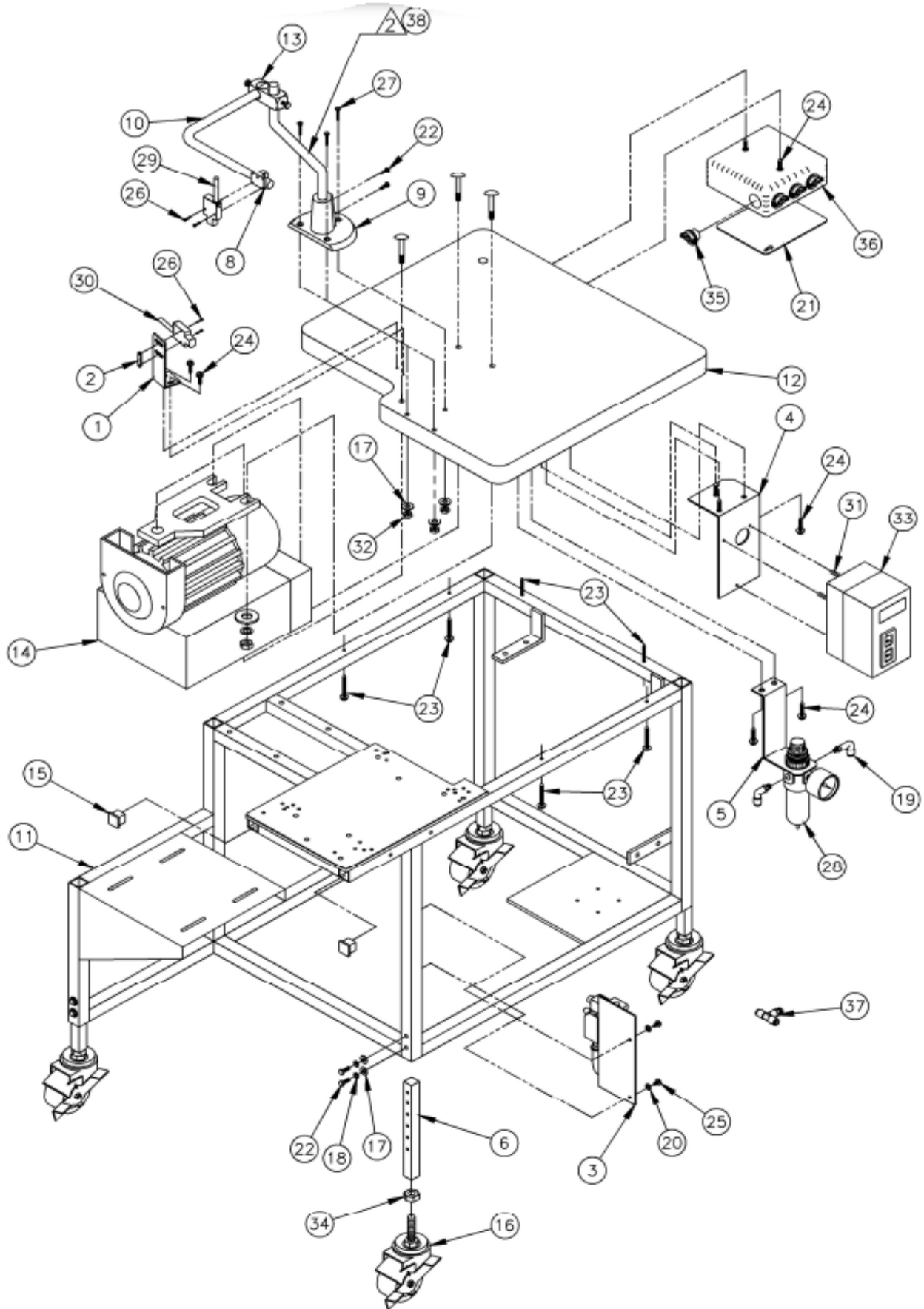

AP-26MGP parts list

NO.	QTY	PART #	DESCRIPTION
1	1	1278-6689	Table Eye Mount
2	1	1975-412A	Nut Plate
3	1	1975011	Venturi & Mounting
4	1	23081	K-CB300 Mntng Bracket
5	1	26078	Brkt, Air Regulator
6	4	26127	Leg
7	1	26273J	Set, Cable
8	1	265155A	Holder, Eye
9	1	265157	Base, Elec Eye Mount
10	1	265158	Rod, Eye Assy Holder
11	1	26M-1100	Frame Assy
12	1	26M-1002	Table Top
13	1	28201	Block, Cross
14	1	4059-D9	Panaservo-AC Motor
15	2	MM132-1202	Square End Cap
16	4	MM503022LB	Caster, Rubber
17	11	WWFS1/4	SAE Flat Washer
18	8	WWL1/4	Lock Washer
19	2	AAQME-4-8	Quick Male Elbow
20	2	WWSI10	Int Tooth Washer
21	1	K-234	Cover
22	10	SSHC01048	Scr,Hx Cp 1/4-20x3/4
23	6	SSZH#10128	Scr,Hx Sh Me #10x2
24	9	SSZH#10064	Scr,Hx Sh Me #10x1
25	2	SSPPT98032	Scr,Pn Hd Ph 10-32x1/2
26	4	SSPS70048	Scr,Pn Hd Sl 4-40x3/4
27	3	SSFS01128	Scr,Fl Sl 1/4-20x2
28	1	AA1981-5102	Reg W/Gauge
29	1	23140A	Electric Eye
30	1	FFSM312LVQ	Electric Eye
31	3	SSPS90024	Scr,Pn Hd Sl 8-32x3/8
32	3	NNK1/4-20	Kep Nut
33	1	K-CB600	Circuit Breaker
34	4	NNH1/2-13	Hex Nut
35	4	K-235	Romax Connector
36	1	K-233	Box, Elec, Square
37	1	AAQBT-4-8	Quick Branch "T"
38	REF	26220A	Rod, Stand, Bent

# AP-26MEG Console, Generic, Efka

AAC Drawing Number 192872C Rev 2

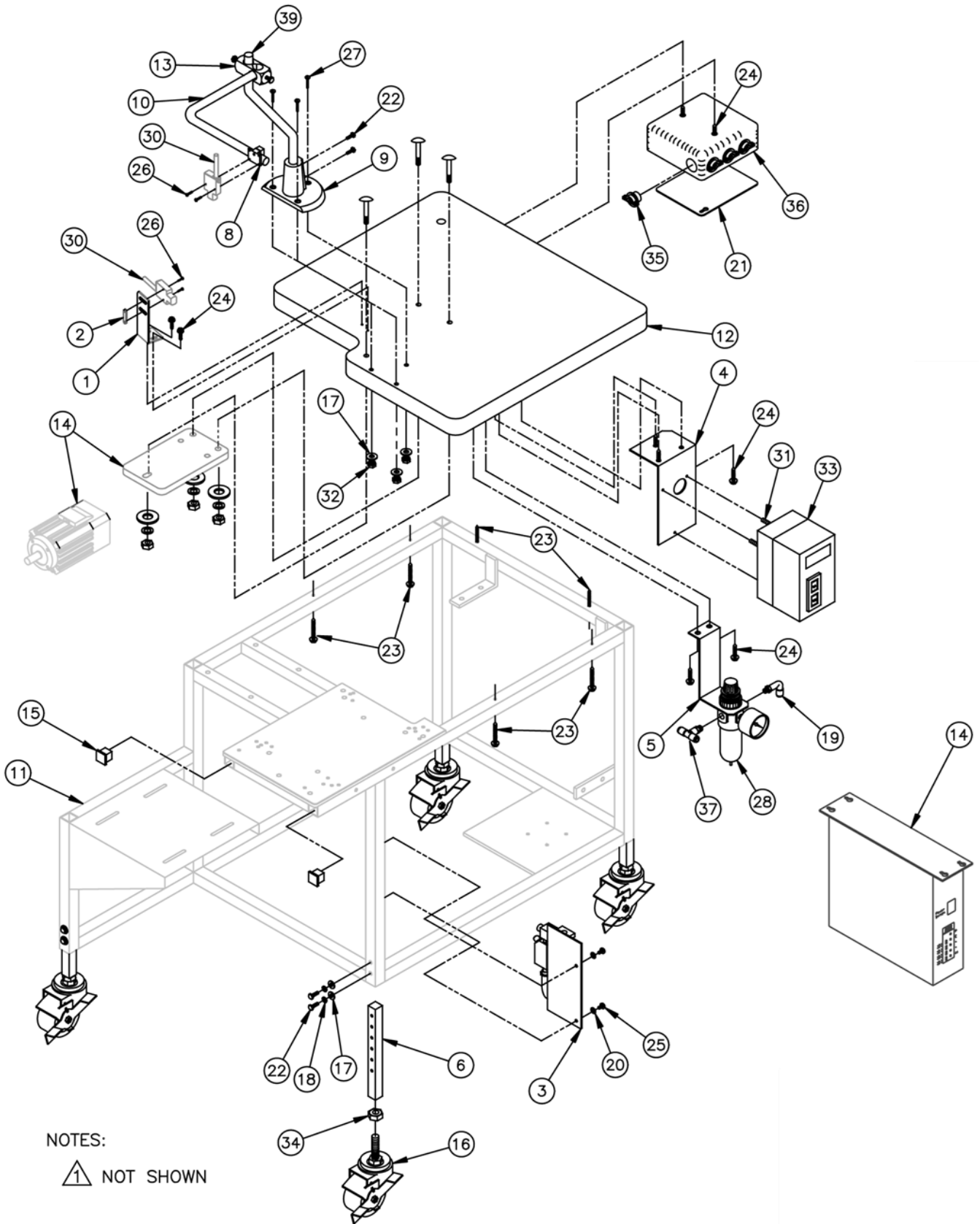

NOTES:

△ NOT SHOWN

AP-26MEG parts list

NO.	QTY	PART #	DESCRIPTION
1	1	1278-6689	Table Eye Mount
2	1	1975-412A	Nut Plate
3	1	1975-512A	Venturi & Mnt
4	1	23081	Mount Brkt
5	1	26078	Air Regulator Brkt
6	4	26127	Leg, 8.25L
7	1	EE37F3311	Power Cord
8	1	265155A	Eye Holder
9	1	265157	Eye Mnt Base
10	1	265158	Rod
11	1	26M-1100	Frame Assy
12	1	26M-1002	Table Top
13	1	28201	Cross Block
14	1	4059-DC1500	Efka Motor
15	2	MM132-1202	End Cap
16	4	MM503022LB	Rubber Caster
17	11	WWFS1/4	Flat Washer
18	8	WWL1/4	Lock Washer
19	2	AAQME-4-8	Quick Male Elbow
20	2	WWSI10	Internal Tooth Washer
21	1	K-234	Cover
22	10	SSHC01048	Screw, Hex Cap
23	6	SSZH#10128	Screw, Sheet Metal
24	9	SSZH#10064	Screw, Sheet Metal
25	2	SSPPT98032	Screw, Pan Head
26	4	SSPS70048	Screw, Pan Head
27	3	SSFS01128	Screw, Flat Slotted
28	1	AA198-5102	Regulator
29	1	0211-702A	Cable
30	2	FFSM312LVQ	Electric Eye
31	3	SSPS90024	Screw, Pan Slotted
32	3	NNK1/4-20	Kep Nut
33	1	K-CB600	Circuit Breaker
34	4	NNH1/4-13	Hex Nut
35	4	K-235	Romax Conn.
36	1	K-233	Electrical Box
37	1	AAQBT-4-8	Quick Branch, T
38	1	28-512	Cable
39	1	26220A	Bent Rod

# 1975-512A Venturi and Mounting Bracket

AAC Drawing Number 260622A Rev 10

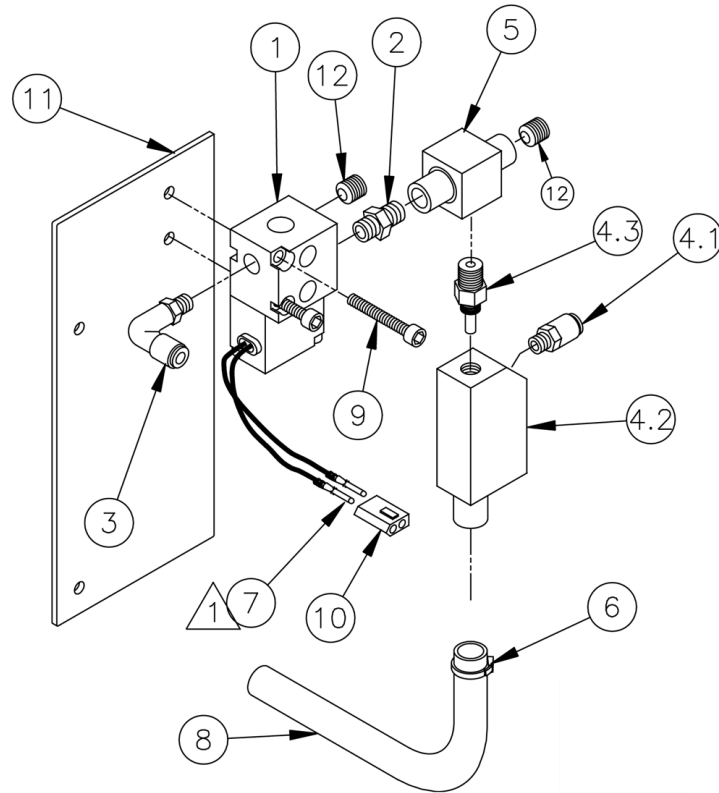

NOTES:

- △ 1 CUT SOLENOID LEADS TO 6" LENGTH.  
ATTACH MOLEX PINS (ITEM 7) TO WIRES.

NO.	QTY	PART #	DESCRIPTION
1	1	AAE45A24D	Valve, 4 Way
2	1	AAF122A-A	Hex Nipple, 1/8
3	1	AAQME-4-8	Quick Male Elbow
4	1	AAV#33-4	Venturi Assembly
4.1	1	AAQMC-4-8	Quick Male Conn
4.2	1	AAV#33-4A	4.8 CFM Vac Generator
4.3	1	AAVR-210A	Pressure Fittin
5	1	AAVS125	Shuttle Valve
6	1	EE6X750	Cable Tie, 4 1/2
7	2	FF31F1022	Pin, Male .093
8	5'	MM163VT-20	Clear Plastic Tubing
9	2	SSSC90064	Scr,So Cp 8-32x1
10	1	FF59F1802	2 Pin Male Connector
11	1	1975-511	Mount Bracket
12	2	MM4554K11	1/8" Pipe Lug

# 26M-500 Program Controller

AAC Drawing Number 191866C Rev 4

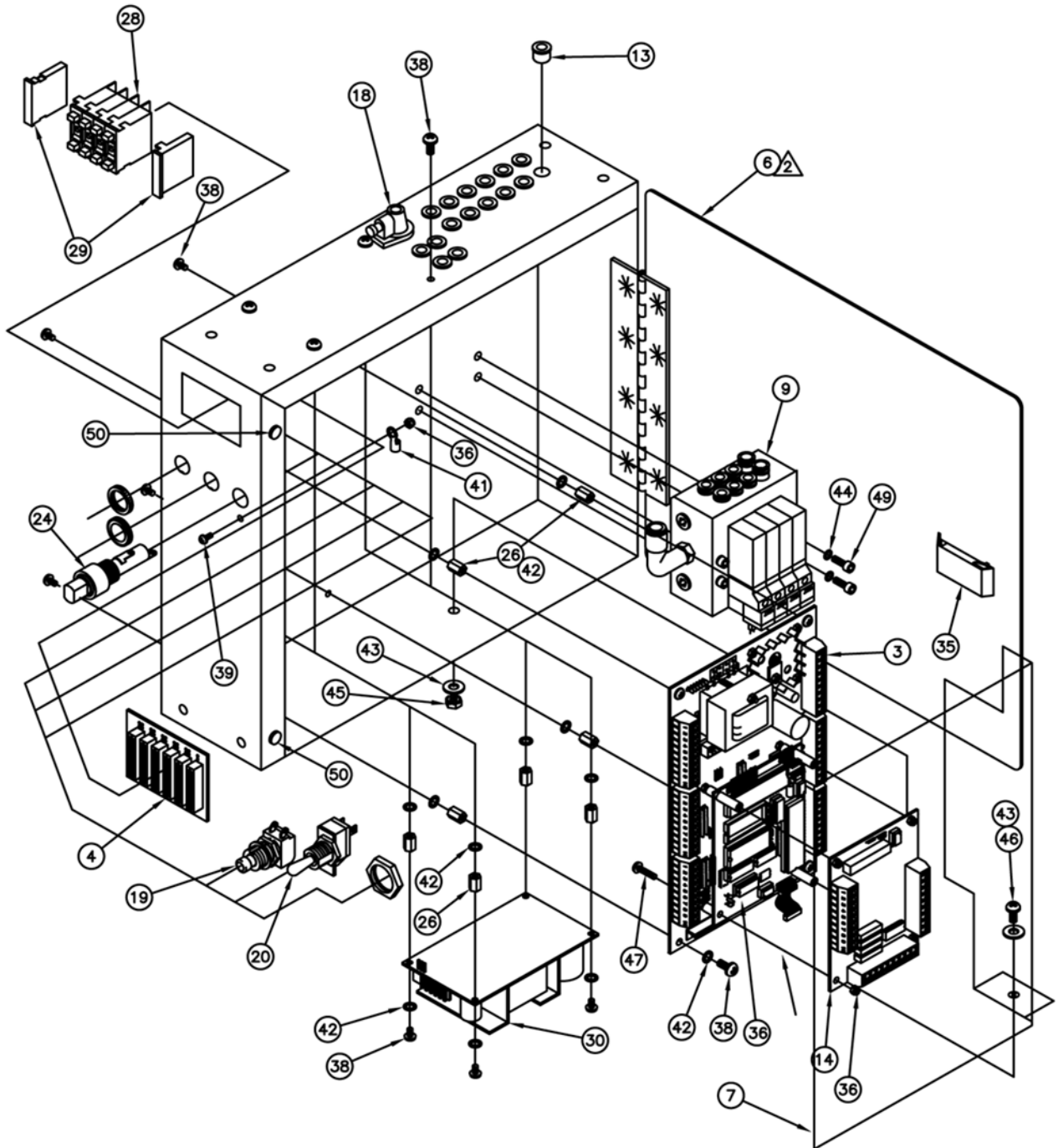

26M-500 parts list

NO	QTY	PART #	DESCRIPTION	NO	QTY	PART #	DESCRIPTION
1	1	0411-2031	FOOT SW ASBLY	26	8	FF67F4078	SPACER
2	1	1987149F3	CABLE, 26 COND	27	2	FF81F4591	PIGGY-BACK CONN
3	1	1987-149JC	PC BOARD	28	4	FFC5.2LST1	THUMBWHEEL SW
4	1	1987-517	PC BOARD	29	1	FFC5S1	END CAP (PAIR)
5	AR	26M-500WD	DIAGRAM, WIRING	30	1	FFNFS40	POWER SUPPLY
6	1	26M-501	CONTROL BOX	31	1	FFRK44T-4	CABLE
7	1	26M-502	PLASTIC COVER	32	1	FFSC15603	STRAIN RELIEF
8	1	40-313	CABLE	33	1	FFCS15606	STRAIN RELIEF
9	1	AAE211E-4	SOL ASBLY	34	1	MM2732A	EPROM
10	1	AP-28-610	CABLE	35	1	MM40450010	LATCH
11	3	EE18-3	WIRE	36	9	NNE6-32	NUT
12	4	EE8205	WIRE	37	AR	SSA-0040	SILKSCREEN
13	16	EESB-375-4	HEYCO BUSHING	38	16	SSPP80016	SCREW, PAN HD PHIL. 6-32 X 1/4
14	1	FF1035-02	P.C.BOARD	39	1	SSPP80032	SCREW, PAN HD PHIL. 6-32 X 1/2
15	8	FF12F1042	BARRIER STRIP 10 PIN	40	4	TT1825	QUICK SLIDE TERMINAL 3/16
16	1	FF156F1803	CONNECTOR	41	1	TT5802	QUICK SLIDE TERMINAL 1/4
17	1	FF156F2206	CONNECTOR	42	16	WWSI6	WASHER, #6 INT TOOTH
18	1	FF1724	STRAIN RELIEF	43	2	WWF8	FLAT WASHER
19	1	FF23F118	P.B. SWITCH	44	4	WWSI8	WASHER,INT TOOTH
20	1	FF23F385	TOGGLE SWITCH	45	1	NNK8-32	KEP NUT
21	1	FF250LA40A	METAL OXIDE VARISTOR	46	1	SSPP90032	SCREW, PAN HD PHIL. 8-32 X 1/2
22	1	FF313500	FUSE, 1/2A	47	4	SSPP80096	SCREW, PAN HD PHIL. 6-32 X 1-1/2
23	2	FF31F1033	FM SOCKET	48	1	1987-513A	CABLE
24	1	FF342838A	FUSE HOLDER	49	4	SSSC90064	SCREW, SOCKET CAP 8-32 X 1
25	1	FF59F1802	M CONNECTOR	50	2	MMSLD-ECH	RUBBER BUMPER

# 26ME-500 Program Controller

AAC Drawing Number 192869C Rev 3

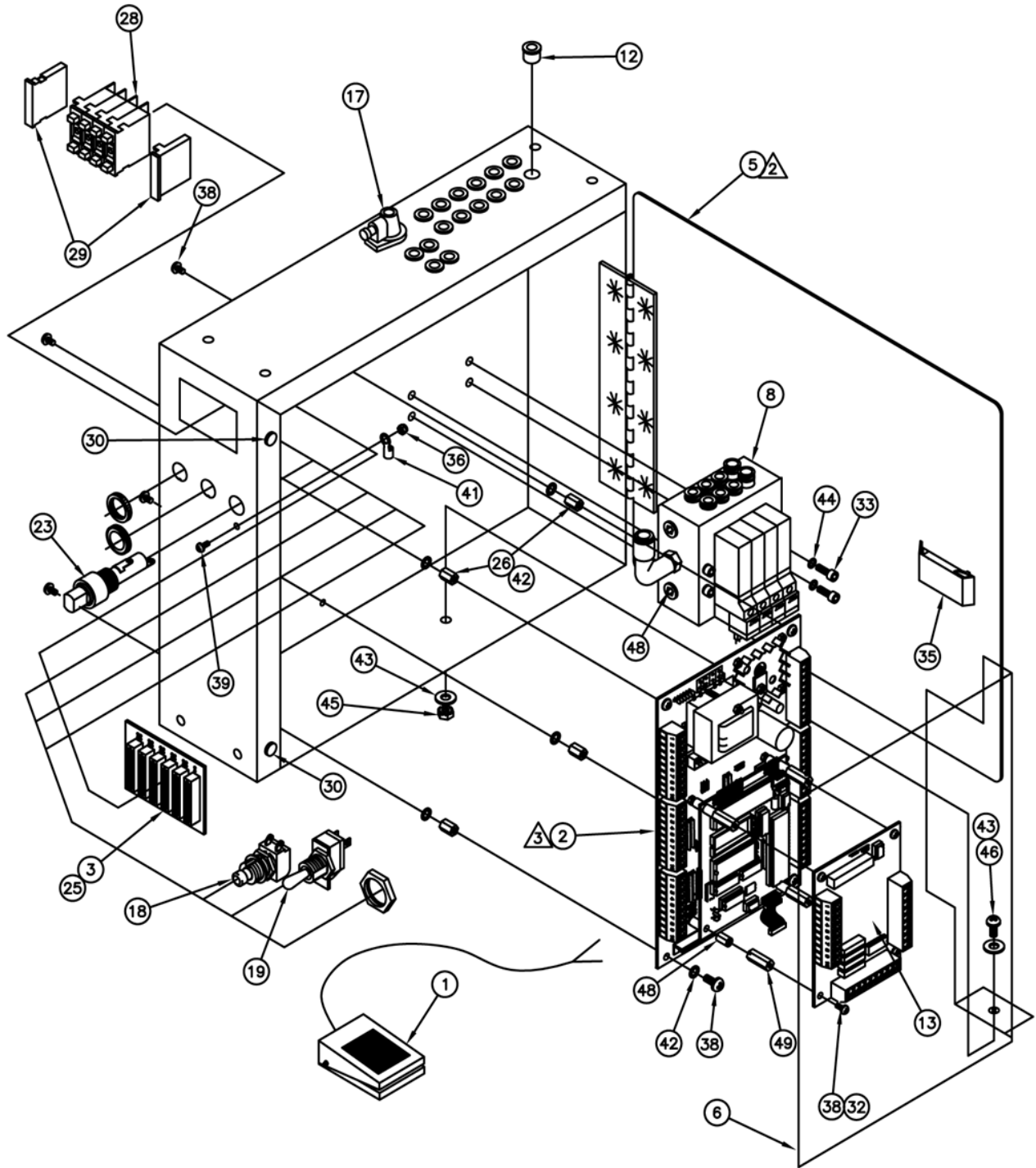

26ME-500 parts list

NO	QTY	PART #	DESCRIPTION	NO	QTY	PART #	DESCRIPTION
1	1	0411-2031	FOOT SW ASBLY	27	2	FF81F4591	PIGGY-BACK CONN
2	1	1987-149JC	PC BOARD	28	4	FFC5.2LST1	THUMBWHEEL SW
3	1	1987-517	PC BOARD	29	1	FFC5S1	END CAP (PAIR)
4	AR	26ME-500WD	DIAGRAM, WIRING	30	2	MMSLD-ECH	RUBBER BUMPER
5	1	26M-501	CONTROL BOX	31	1	FFRK44T-4	CABLE
6	1	26M-502	PLASTIC COVER	32	4	WWL6	LOCK WASHER
7	1	AP-28-612N	CABLE, EFKA	33	4	SSSC90080	SCREW, SOCKET CAP 8-32 X 1
8	1	AAE211E-4	SOL ASBLY	34	1	1987-513A	CABLE
9	1	AP-28-610	CABLE	35	1	MM40450010	LATCH
10	3	EE18-3	WIRE	36	1	NNE6-32	NUT
11	4	EE8205	WIRE	37	AR	SSA-0040	SILKSCREEN
12	16	EESB-375-4	HEYCO BUSHING	38	12	SSPP80016	SCREW, PAN HD PHIL 6-32 X1/4
13	1	FF1035-02	P.C.BOARD,TREADLE	39	1	SSPP80032	SCREW, PAN HD PHIL 6-32 X1/2
14	1	1953-120	CABLE	40	4	TT1825	QUICK SLIDE TERMINAL 3/16
15	1	0211-705C	CABLE	41	1	TT5802	QUICK SLIDE TERMINAL 1/4
16	1	FF171-16	CABLE	42	8	WWSI6	WASHER, #6 INT TOOTH
17	1	FF1724	STRAIN RELIEF	43	2	WWF8	FLAT WASHER
18	1	FF23F118	P.B. SWITCH	44	4	WWSI8	WASHER,INT TOOTH
19	1	FF23F385	TOGGLE SWITCH	45	1	NNK8-32	KEP NUT
20	1	FF250LA40A	METAL OXIDE VARISTOR	46	1	SSPP90032	SCREW, PAN HD PHIL 8-32 X 1/2
21	1	FF313500	FUSE, 1/2A	47	4	FF89F2608	SPACER
22	2	FF31F1033	FM SOCKET	48	4	FF67F4079	SPACER, 1/2 THDED
23	1	FF342838A	FUSE HOLDER	49	1	1987149F3	CABLE,26 CON RIBBON
24	1	FF59F1802	M CONNECTOR	50	1	FF1024A-PGM	INS,FF1024A POT SETTINGS
25	2	FF609-1030	SOCKET	51	1	26ME-LAB	LABEL,SETTING CONV SPEED
26	4	FF67F4078	SPACER	52	3	MM4554K11	PLUG,1/8"NPT PIPE

# 1336021 PLC Control Box Assembly

AAC Drawing Number 1336021 Rev 4

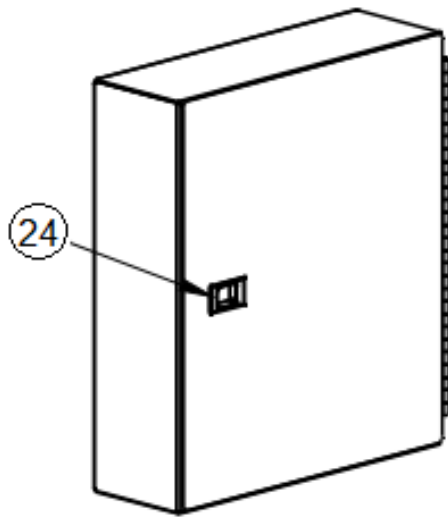
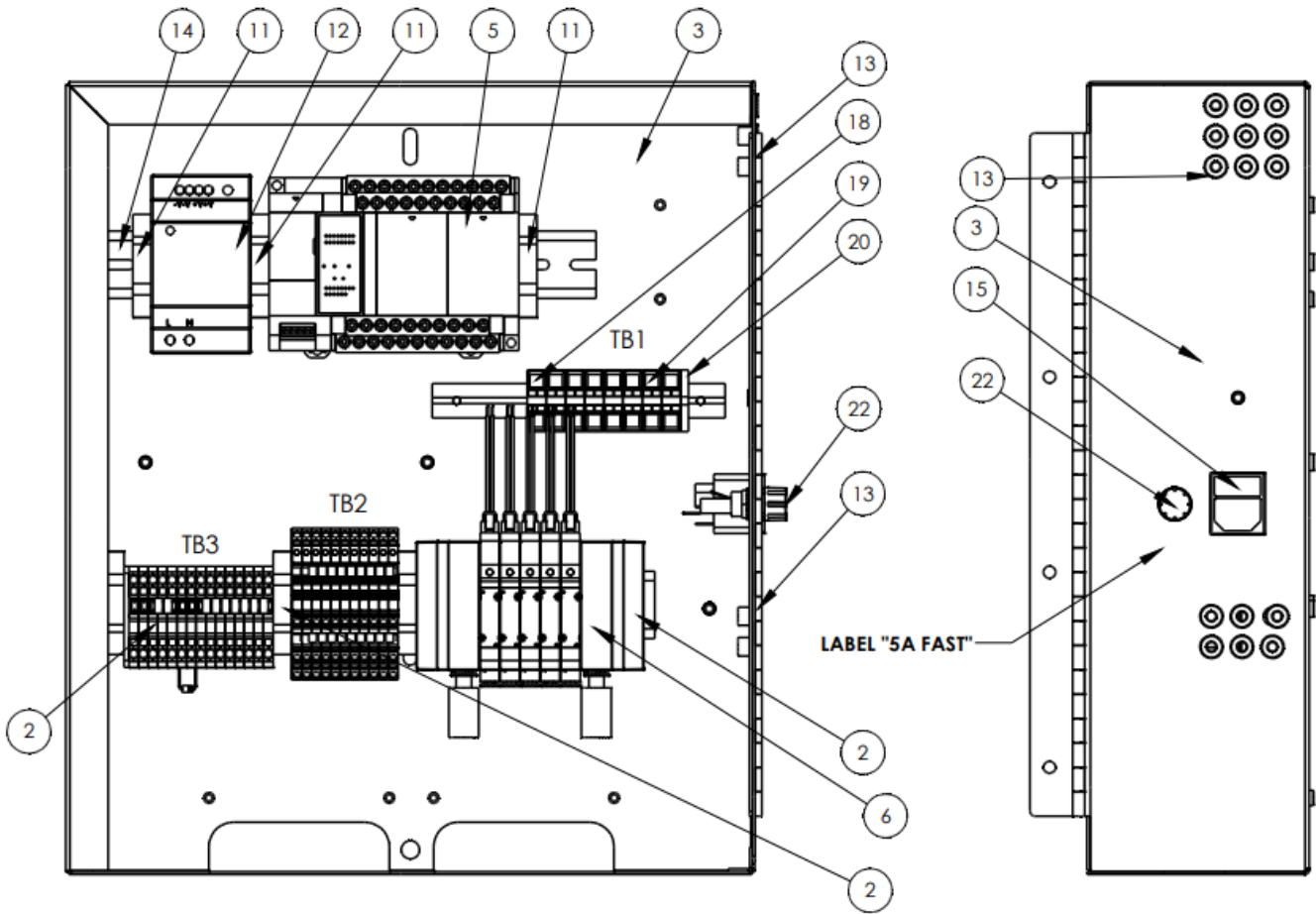

1336021 parts list

ITEM NO.	NO DOOR/QTY.	PART NUMBER	DESCRIPTION
1	1	0411-2031	FOOT SWITCH ASSEMBLY,
2	1	1336007	WAGO TERMINAL ASSEMBLY
3	1	1336020	CONTROL BOX, PLC, DOOR, RIGHT
4	1	1336023	COVER, CNTL BOX, LEXAN
5	1	AAAFPXHC30RD	CONTROLLER, PLC, 30 I/O
6	1	AAE1335-5	VALVE BANK ASSY. 5 @ 5/32
7	1	AP-28-610	CABLE,REMOTE JOG
8	1	AP-28-612RB	CABLE, SYNC, FL, N/D, MR
9	1	AP26MPLC-WD1	WIRING DIA., PLC, AP26M
10	1	AP26MPLC-WD2	WIRING DIA., POWER, AP26M-PLC
11	3	EECLIPFIX	ANCHOR,DIN RAIL
12	1	EEDR6024	POWER SUP,SWITCHER,24V
13	15	EESB-375-3	HEYCO BUSHING 3/16" ID
14	10 IN	EETS35X7.5A	DIN RAIL-AMERICAN
15	1	FF10ESB1C	CONNECTOR,POWER ENTRY
16	2' (*)	FF36F056WA	CABLE,8 COND,22 AWG
17	1	FF264-3BKT6	MOUNT, WAGO, 11 DBLS
18	6	FF264-341	TERMBLK,WAGO,TOP,DUAL,GRY
19	2	FF264-347	TERMBLK,WAGO,TOP,DUAL,GRN
20	1	FF264-371	TERMBLK,WAGO,TOP,END
21	1	FF270-1278	FUSE, 5A, FAST
22	1	FF342838A	FUSE HOLDER, PANEL MOUNT
23	1	FFR2K	RESISTOR, 2K, 1/4W
24	1	MM40450010	FASTENER,SLIDE LOCK

# AAE211E-4 4 Station Solenoid Assembly

AAC Drawing Number 191051A Rev 2

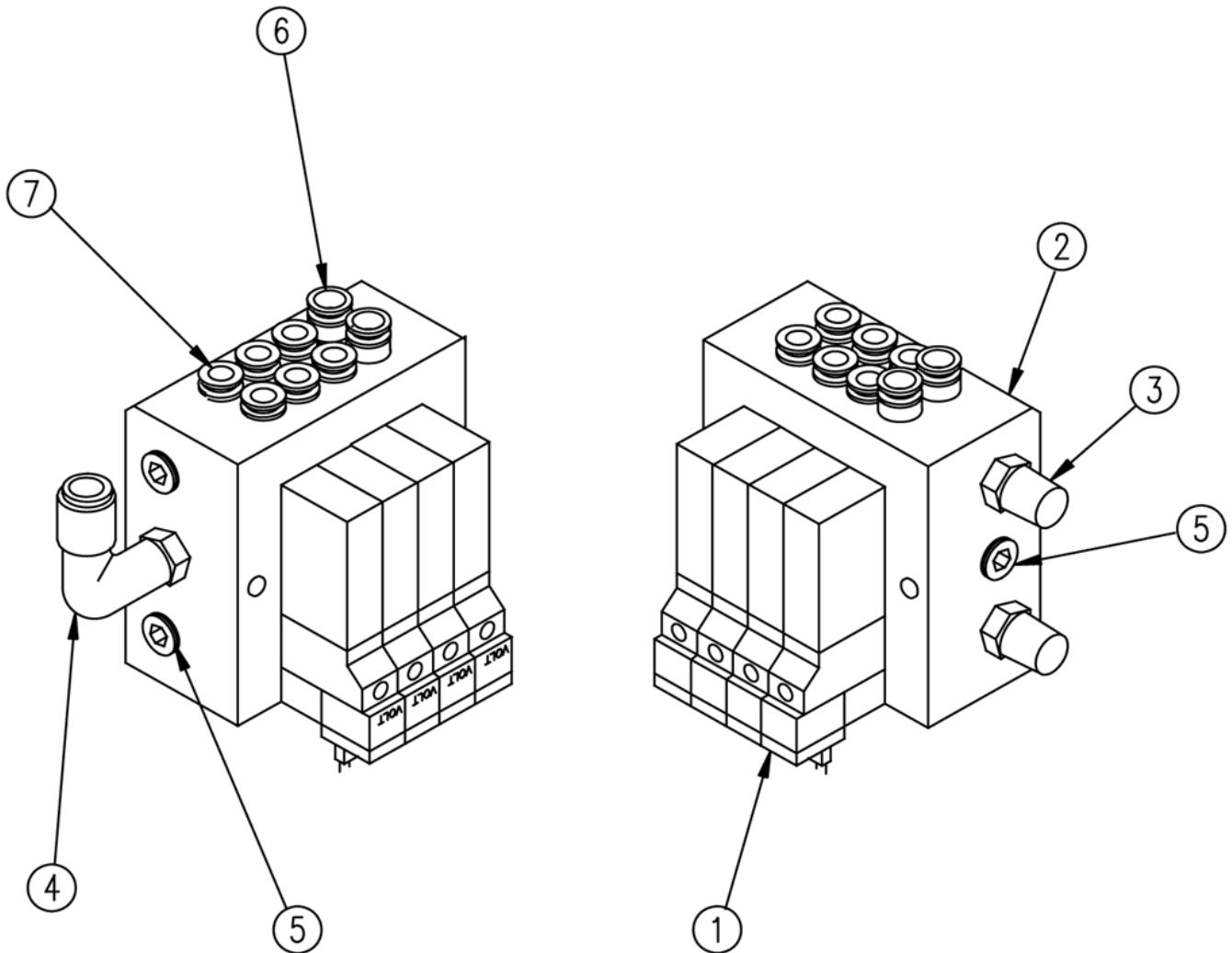

NO.	QTY	PART #	DESCRIPTION	NO.	QTY	PART #	DESCRIPTION
1	4	VQZ1151-5L0	Solenoid Valve	5	3	MM4554K11	Plug, 1/8
2	1	VV5QZ15-04	Manifold	6	2	VVQ1000-50A-N7	One Touch, 1/4
3	2	AN110-01	Silencer	7	6	VVQ1000-50A-N3	One Touch, 5/32
4	1	AAQME-4-8	Quick Male Elbow				

# AP-26M-03 Conveyor Assembly

AAC Drawing Number 191868C Rev 8

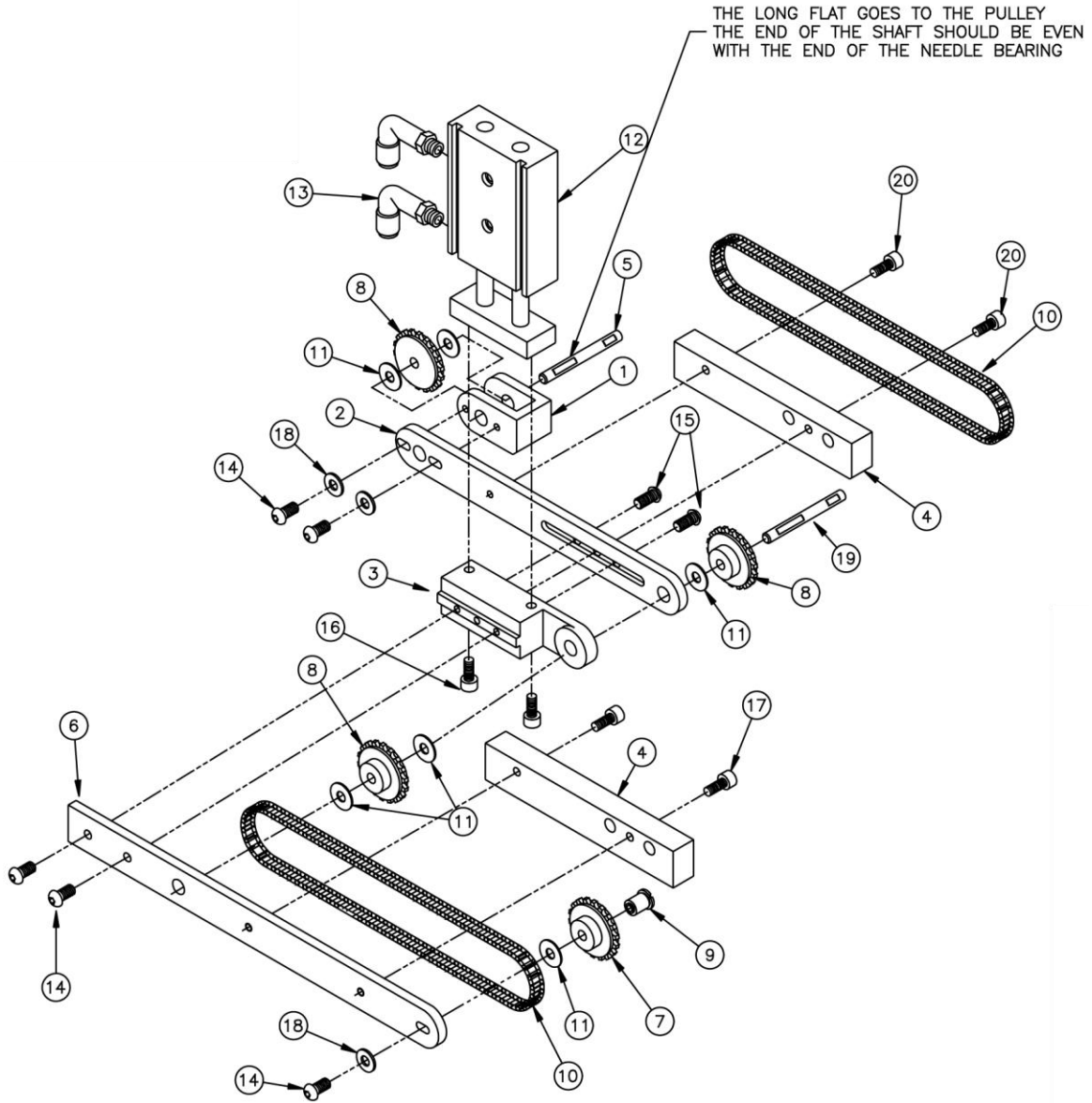

NO.	QTY	PART #	DESCRIPTION	NO.	QTY	PART #	DESCRIPTION
1	1	26M-3001	Support, Shaft	11	5	BBTRA411	Thrust Washer
2	1	26M-3002	Arm, Short	12	1	AACXSM2020	Cylinder, Guided
3	1	26M-3003	Block, Conn	13	2	AAQME-5-10	Elbow
4	2	26M-3004	Guide, Long	14	5	SSBC98032	Scr,But Cp 10-32x1/2
5	1	26M-3005	Jackshaft, 2.44L	15	3	SSSC98040	Scr,So Cp 10-32x5/8
26	1	26M-3006	Arm, Long	16	2	SSSCM5X30	Scr,So Cp 5mmx30mm
7	1	011-037	Idler Sprocket	17	3	SSSC98032	Scr,So Cp 10-32x1/2
8	3	011-039	Drive Sprocket	18	3	WWFS10	SAE Flat Washer
9	1	011-041	Stud	19	1	26M-3007	Jackshaft, 2.04L
10	2	MM25CCF080	Chain, Flex	20	2	SSSC95040	Scr, Soc, Cap

# AP-26M-02 Flip Stacker Assembly

AAC Drawing Number 191867C Rev 9

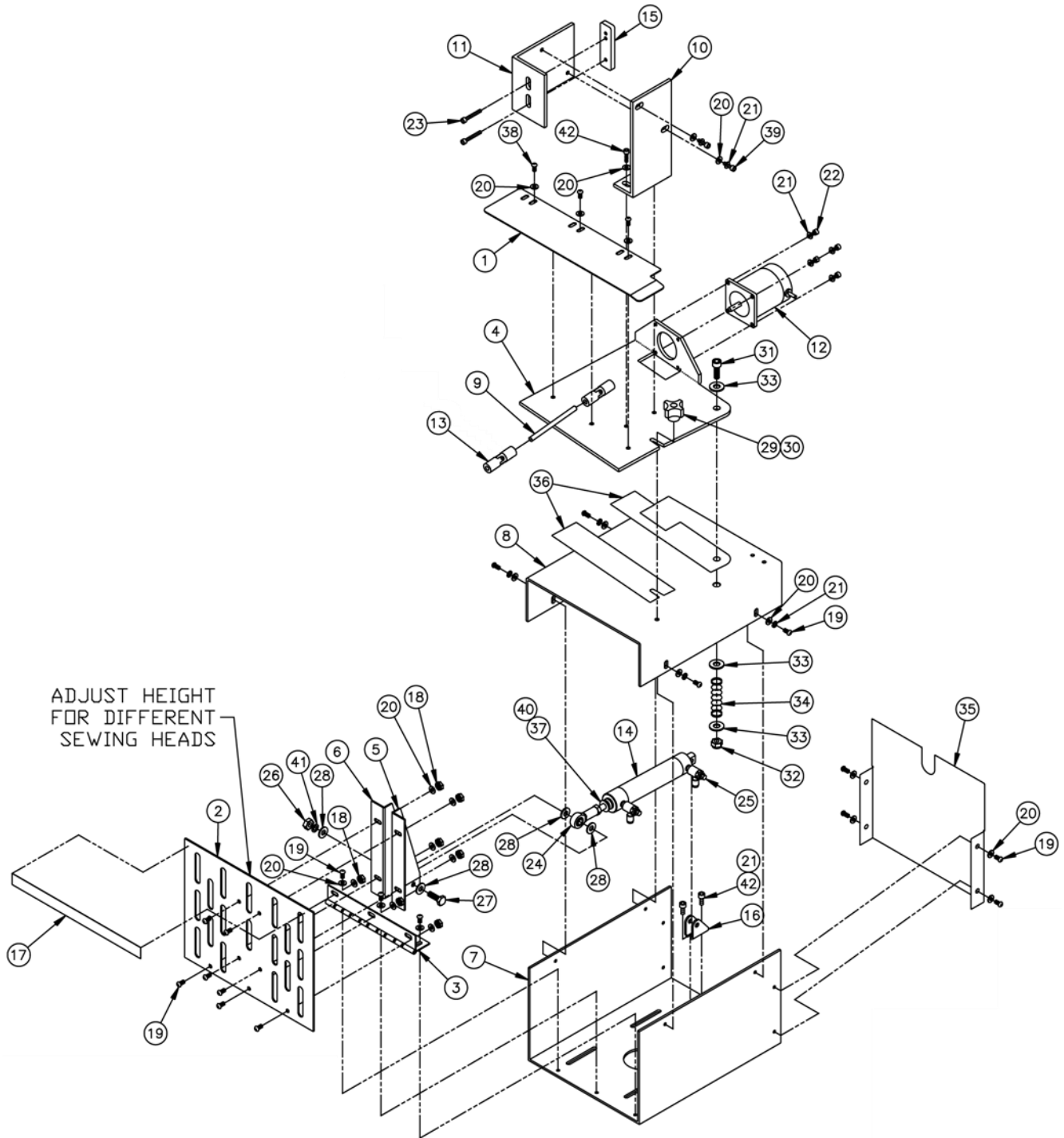

AP-26M-02 parts list

NO.	QTY	PART #	DESCRIPTION	NO.	QTY	PART #	DESCRIPTION
1	1	26M-2001A	Skid Plate	23	2	SSSC98080	Scr,So Cp 10-32x1-1/4
2	1	26M-2002A	Door, Stacker	24	1	BBAW-4	Rod End
3	1	26M-2003	Hinge	25	2	AA198RA508	Flow Control
4	1	26M-2004	Motor Bracket	26	1	NNJ1/4-20	Jam Nut
5	1	26M-2005L	Pivot Bracket, Left	27	1	SSHCO1080	Scr,Hx Hd Cp
6	1	26M-2005R	Pivot Bracket, Right	28	4	WWFS1/4	SAE Flat Washer
7	1	26M-2006	Base Plate	29	1	TTCL1AAPK1	Plastic Knob
8	1	26M-2007	Top Plate	30	1	SSSC98064	Scr,So cp 10-32x1
9	1	26M-2008	Drive Shaft	31	1	SSSC25128	Scr,So Cp 3/8-16x2
10	1	26M-2009	Cylinder Bracket	32	1	NNE3/8-16	Elastic Lock Nut
11	1	26M-2010	Cylinder Mount	33	3	WWF3/8	Flat Washer
12	1	AP-22E-103	Step Motor	34	1	273-4F	Spring
13	2	1987-409	U-Joint, 1/4	35	1	26M-2011	End Plate
14	1	AAC7DP-3	Air Cylinder	36	1.25'	MM130-10A	PTFE Tape
15	1	2112-609	Cyl Slide Plate	37	1	273-4-503	Leather Washer
16	1	AAFBP-11C	Pivot Bracket	38	3	SSBC98016	Scr,But Cp 10-32x1/4
17	1	MM6970T64	Grip Tape	39	2	SSSC98040	Scr, Soc, Cap
18	7	NNK10-32	Keq Nut	40	1	NNJ1/4-28	Jam Nut
19	18	SSBC98024	Scr,But Cp 10-32x3/8	41	1	WWL1/4	Lock Washer
20	27	WWFS10	SAE Flat Washer	42	4	SSSC98024	Scr, Soc, Cap
21	14	WWL10	Lock Washer	43	7"	AATPWL3/4	Loom Wire
22	12	SSSC98032	Scr,So Cp 10-32x1/2				

# 26M-PD Pneumatic Diagram

AAC Drawing Number 125302B Rev 2

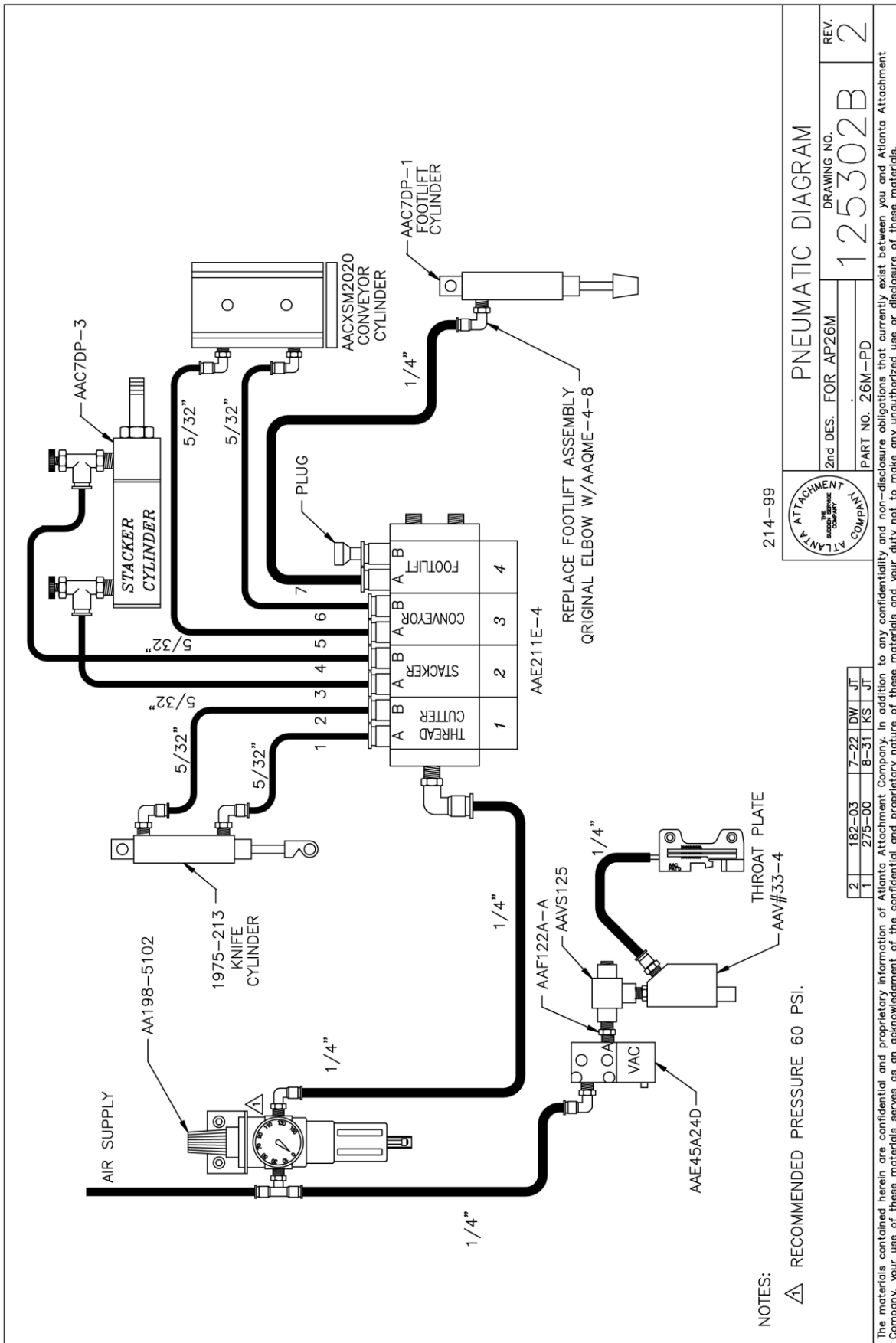

PNEUMATIC DIAGRAM

2nd DES. FOR AP26M

PART NO. 26M-PD

DRAWING NO. 125302B

REV. 2

ATLANTA ATTACHMENT COMPANY

2	182-03	7-22	DW	JT
1	275-00	8-31	KS	JT

The materials contained herein are confidential and proprietary information of Atlanta Attachment Company. In addition to any confidentiality and non-disclosure obligations that currently exist between you and Atlanta Attachment Company, your use of these materials serves as an acknowledgment of the confidential and proprietary nature of these materials and your duty not to make any unauthorized use or disclosure of these materials.







# 26M-500WD Wiring Diagram

AAC Drawing Number 125436C Rev 2

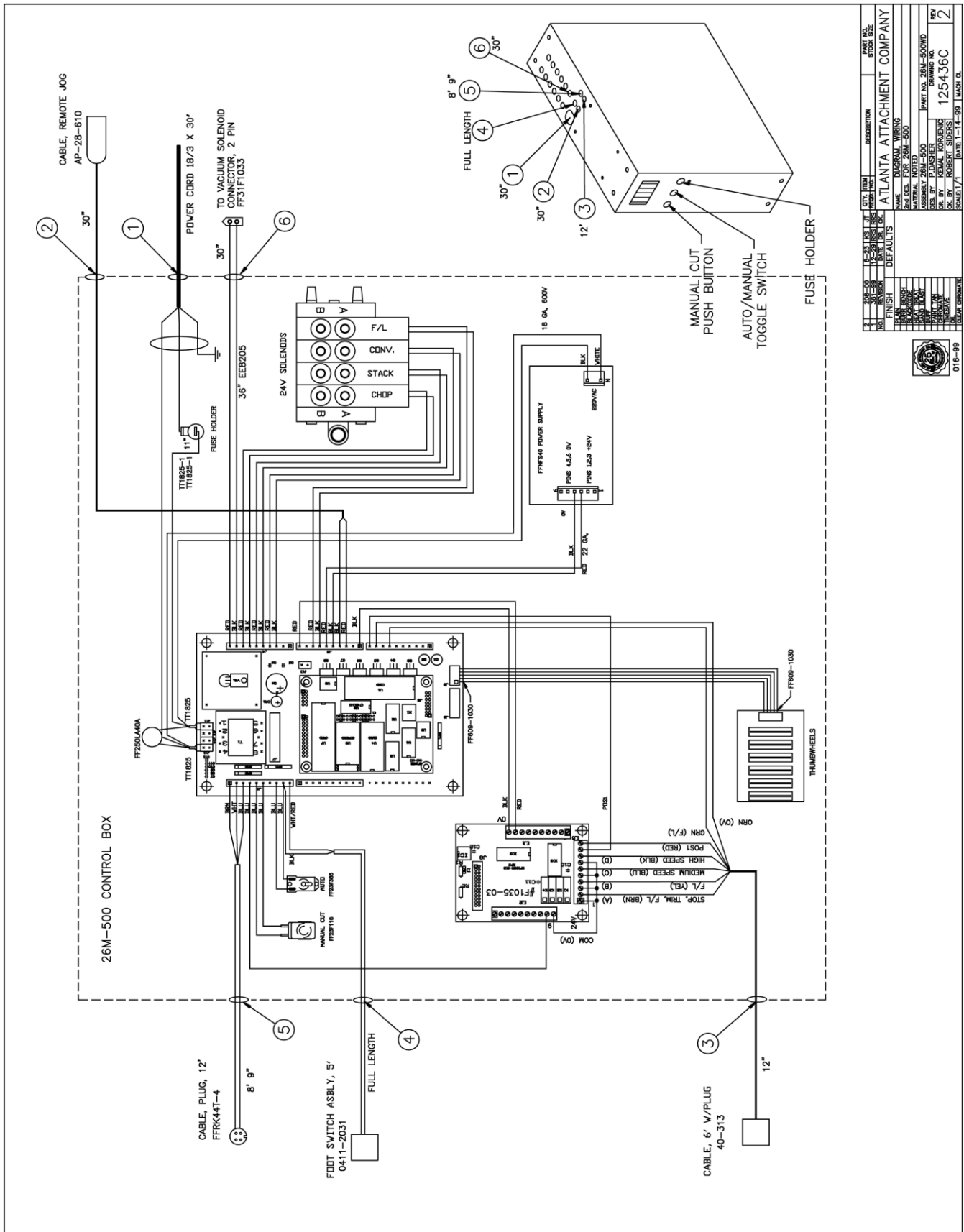

REV	DATE	BY	CHK	DESCRIPTION	ISSUE NO.	REV
1	11-14-99	ROBERT SUZERS	ROBERT SUZERS	INITIAL WIRING	1	
2	11-14-99	ROBERT SUZERS	ROBERT SUZERS	REVISIONS	2	

QTY	ITEM	DESCRIPTION	ISSUE NO.
1	26M-500	CONTROL BOX	1
1	26M-500	CONTROL BOX	1

NAME	POSITION
ROBERT SUZERS	DESIGNER
ROBERT SUZERS	DRAWING NO.
ROBERT SUZERS	PART NO.
ROBERT SUZERS	DATE
ROBERT SUZERS	SCALE

REV	DATE	BY	CHK	DESCRIPTION
1	11-14-99	ROBERT SUZERS	ROBERT SUZERS	INITIAL WIRING
2	11-14-99	ROBERT SUZERS	ROBERT SUZERS	REVISIONS



016-99

# AP26MPLC-WD1

AAC Drawing Number 125471D Rev 4

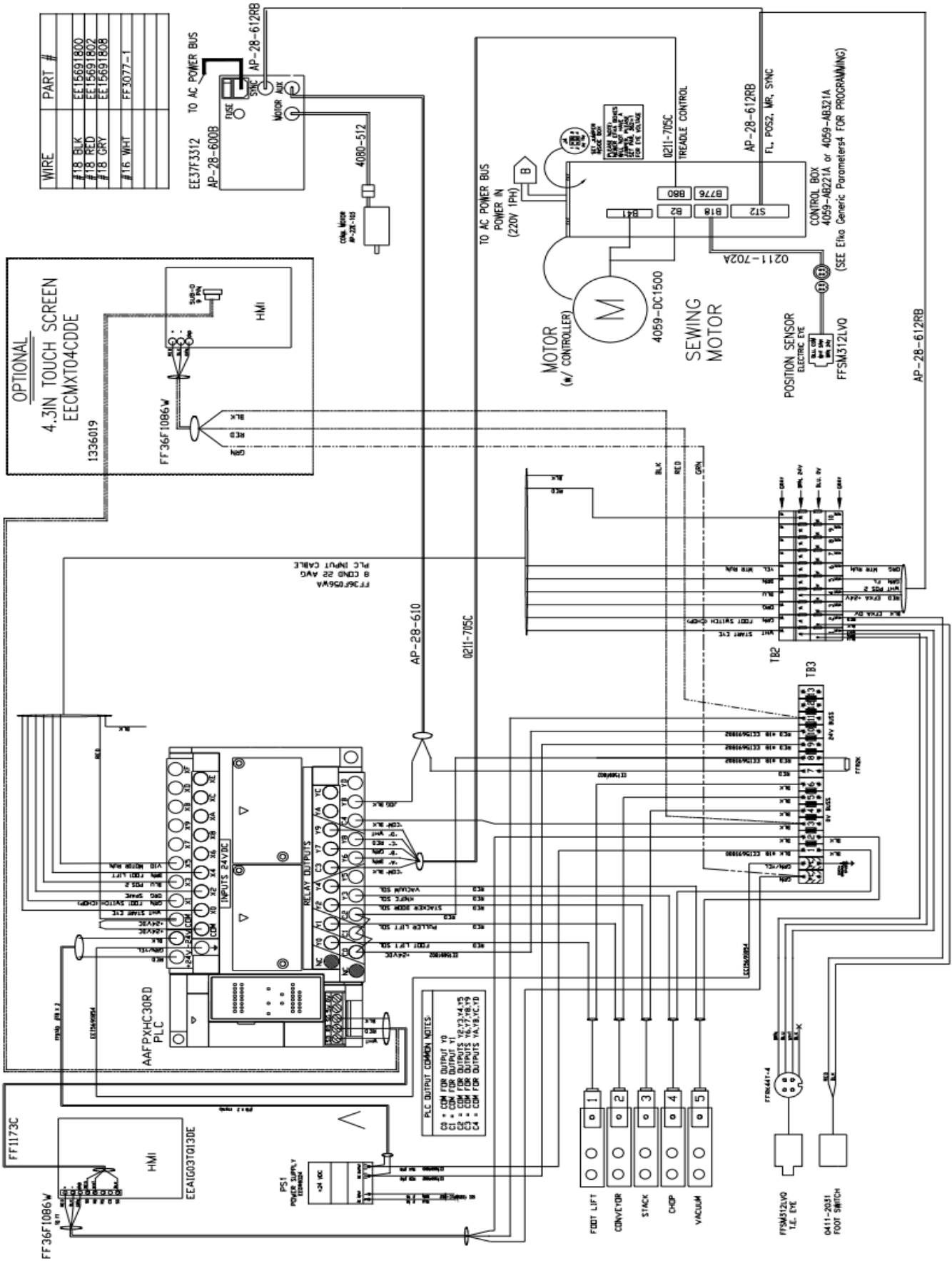

# AP26MPLC-WD2

AAC Drawing Number 125472D Rev 0

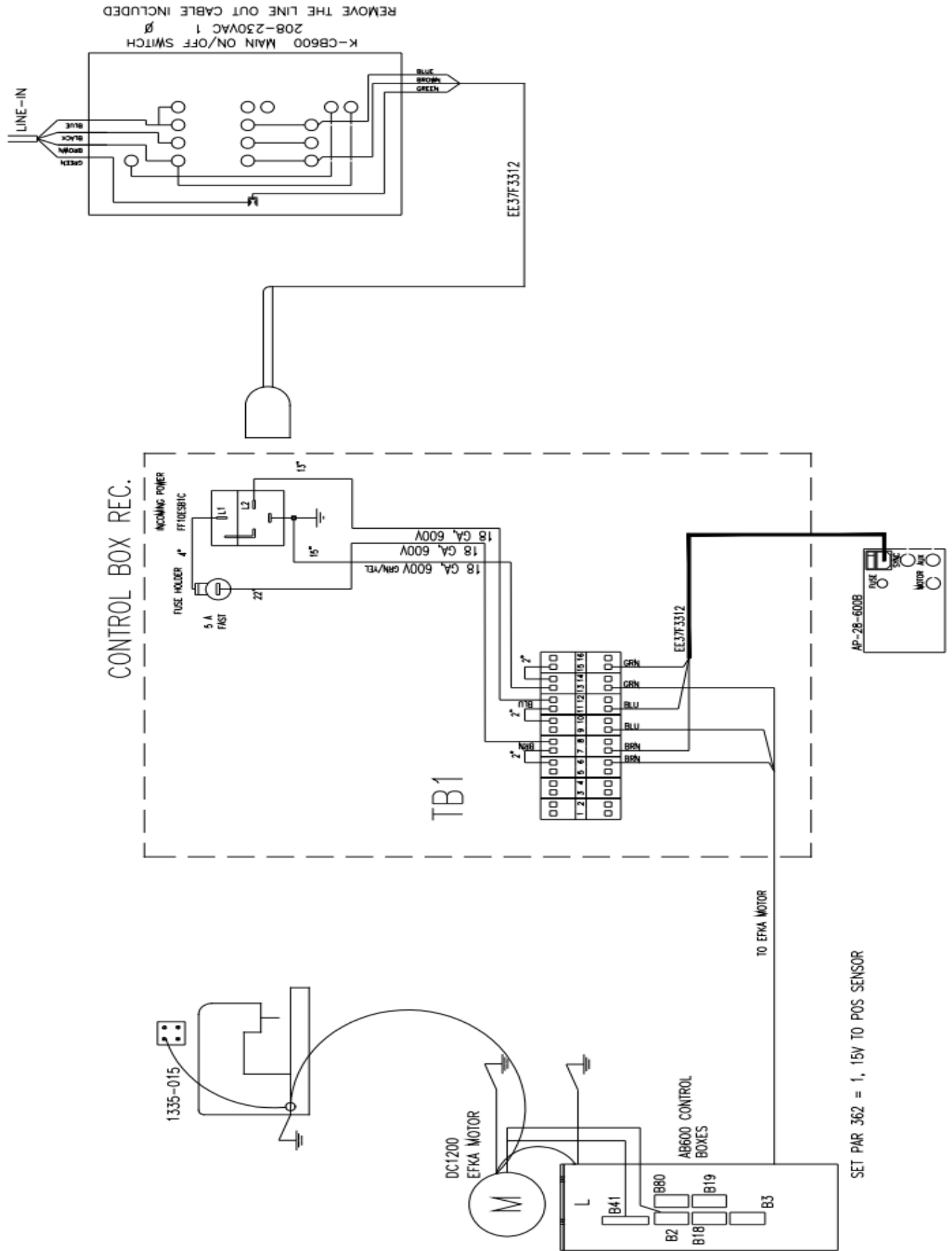

# Sewing Head Details

## AP-26M-06 Sewing Head Detail

AAC Drawing Number 191865C Rev 1

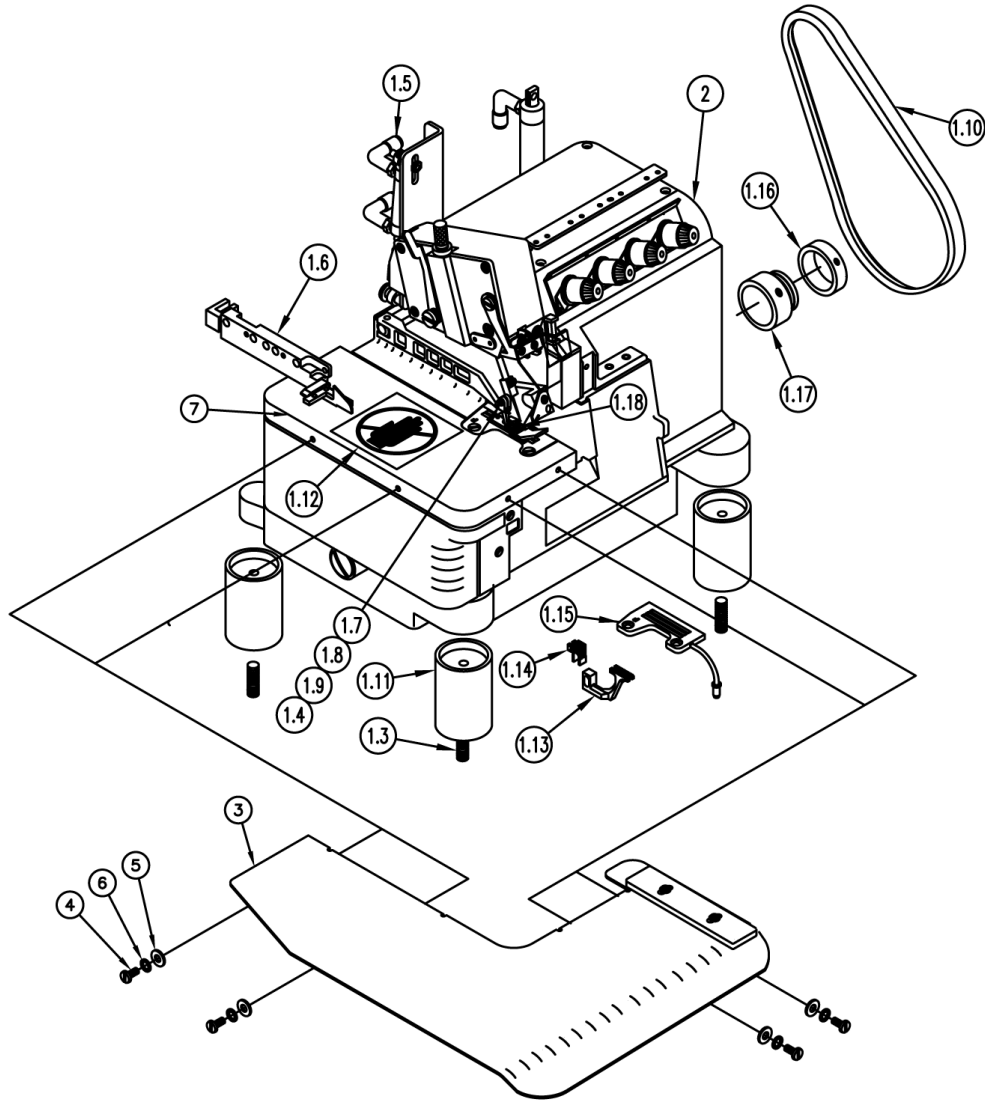

NO.	QTY	PART #	DESCRIPTION	NO.	QTY	PART #	DESCRIPTION
1	1	AP-26M-06S	Sewing Head Sub-Assy	1.11	3	26149A	Isolator Mout
1.1	1	311-129	Tape Mounting	1.12	1	26149M	Isolator Spacer
1.2	1	311-128	Tape Mounting	1.13	1	26220A	Eye Mount
1.3	1	1975-520	Spring Holder Ft	1.14	0	M2Y23-001	Main Feed Dog
1.4	1	SSSS25032	Scr,So St 3/8-16x1/2	1.15	0	M2Y23-002	Differential Feed
1.5	1	SSM185	Scr,Fil Hd 1/8-44x3/8	1.16	1	M1W19-001Y23	Toe
1.6	3	SSSS01032	Scr,So St 1/4-20x1/2	1.17	1	M3Y23-001	Throat Plate
1.7	AR	26276E	Label, Caution	1.18	1	ZX3836	V Belt
1.8	1	1975-400M	Cutter Assy	1.19	1	MMRBAND10	Rubber Band
1.9	1	1975-400S	Cutter & Footlift Pts	2	1	SYAM-8003G	Yamato Sewing Head
1.10	1	1975-519	Spring Holder				

# AP-26M-11 Sewing Head Detail

AAC Drawing Number 191062A Rev 4

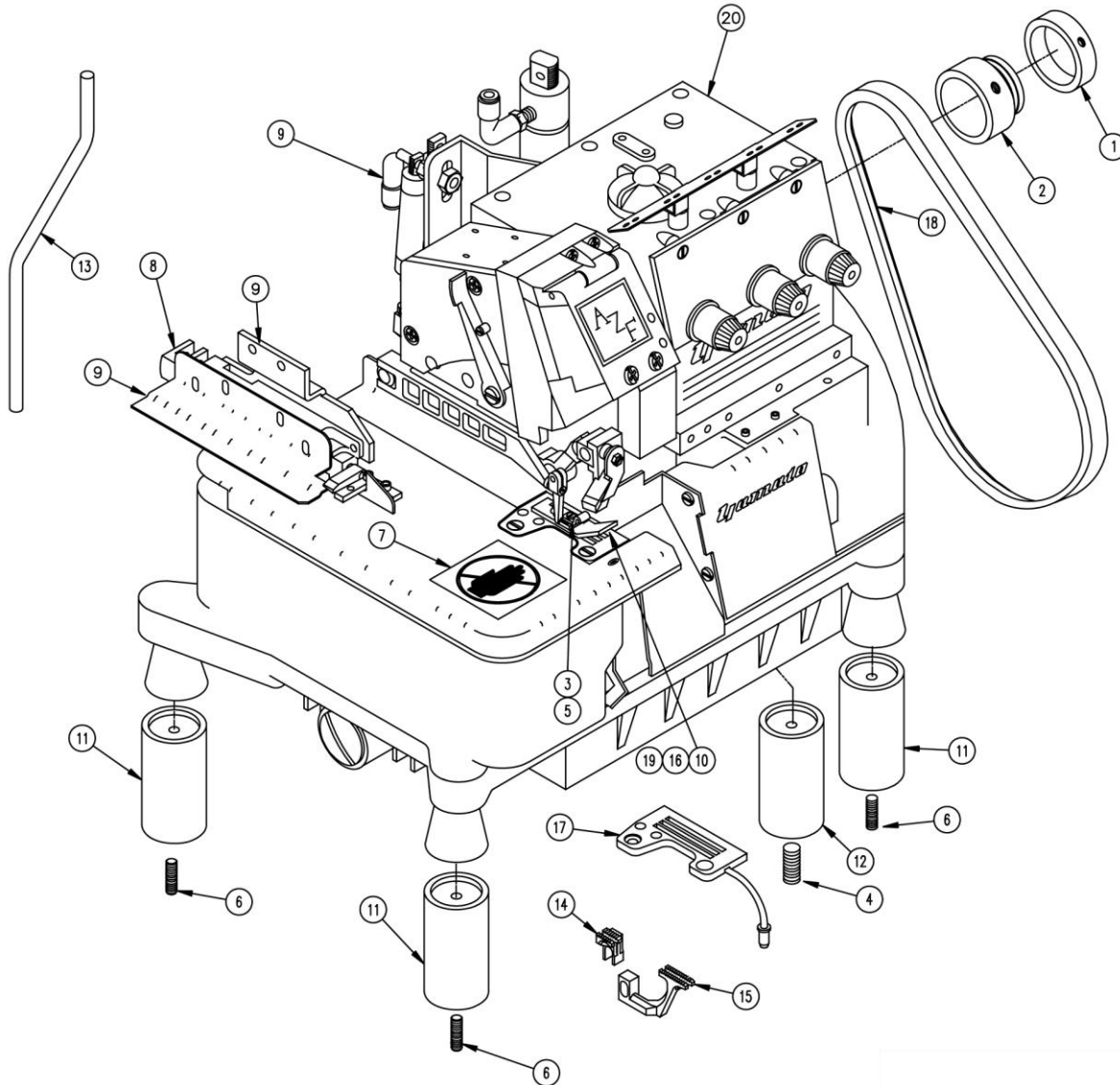

NO	QTY	PART #	DESCRIPTION	NO	QTY	PART #	DESCRIPTION
1	1	AP-26M-11S	SEWING HEAD PARTS	1.14	1	M2G24-002	MAIN FEED DOG
1.3	4	SSSS01032	SCREW, SOC SET 1/4-20 X 1/2	1.15	1	M3G24-001	PLATE, THROAT, BACKLATCH
1.4	1	M1W19-001	FOOT, EXTENDED	1.16	1	311-129	SLEEVE, TAPE MOUNT
1.5	1	1975-400G6	CUTTER & FOOTLIFT COMP	1.17	1	311-128	HUB, HANDWHEEL, TAPE MOUNT
1.6	1	1975-400M	CUTTER ASSEMBLY	1.18	1	SSM185	SCREW, FILISTER HEAD, 1/8-44
1.7	1	1975-519	SPRING RETAINER	2	1	SPEGEX5204	SEWING HEAD
1.8	1	MMRBAND10	RUBBER BAND	3	1	26097C	CLOTH PLATE ASSY
1.9	1	1975-520	MOUNT, SPRING HOLDER	4	4	SSTS85024	SCREW, TRUSS SLOTTED 6-40 X 3/8
1.10	1	ZX3833	V-BELT	5	4	WWB5/32ID	WASHER, BRASS
1.11	4	26281	ISOLATOR MOUNT	6	4	WWSI6	WASHER, INTERNAL TOOTH
1.12	1	26276E	LABEL "CAUTION"	7	1	26097E	CLOTH PLATE
1.13	1	M2G24-001	FEED DOG, DIFF.	8	AR	CLOTH PLATE	LABEL, SEW HEAD

# AP-26M-13 Sewing Head Detail

AAC Drawing Number 191062D Rev 0

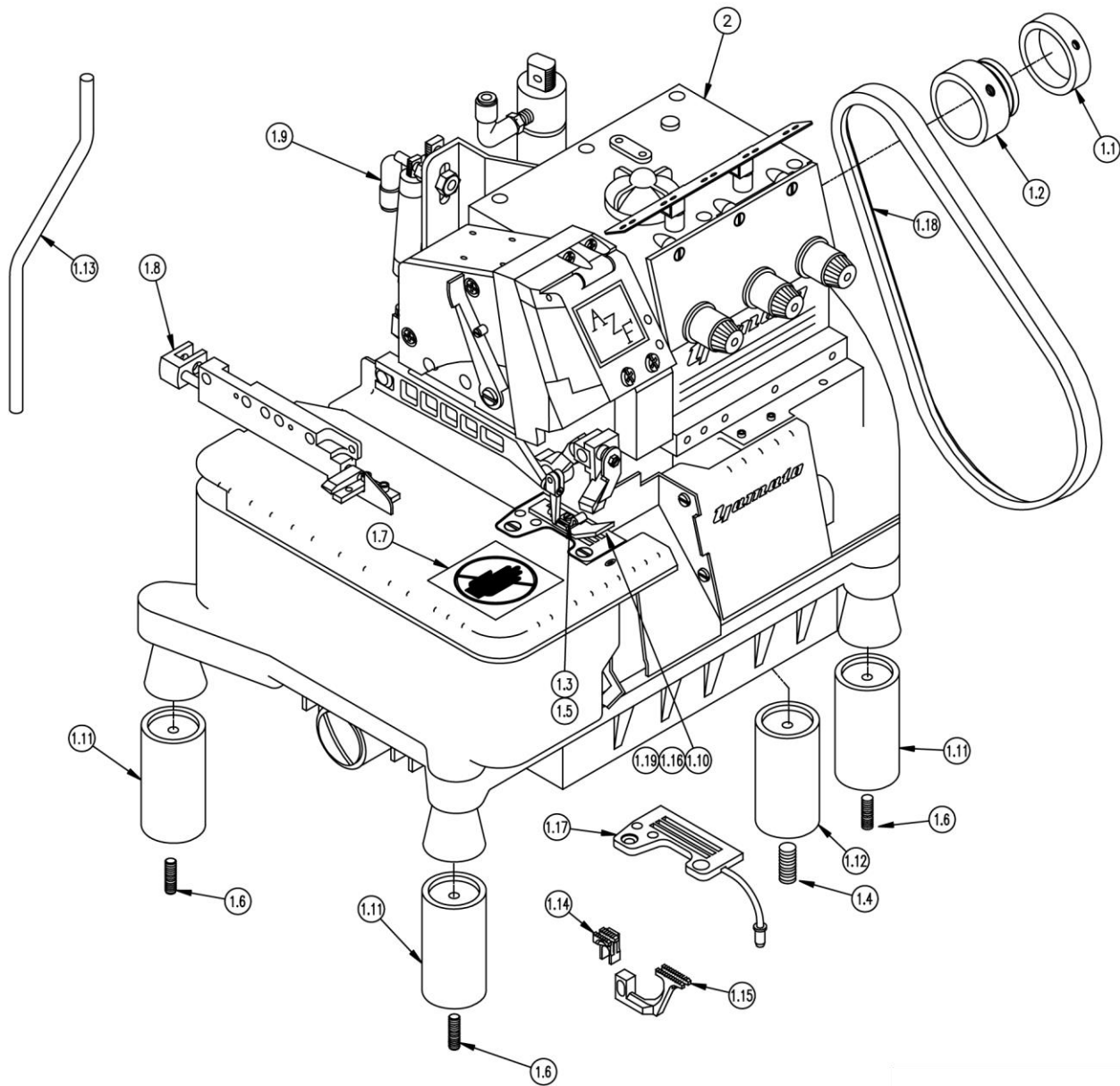

QTY. RECD.	ITEM NO.	DESCRIPTION	PART NO. STOCK SIZE	QTY. RECD.	ITEM NO.	DESCRIPTION	PART NO. STOCK SIZE
AR	8	LABEL,SEW HEAD	26M-LAB	1	1.13	FEED DOG, DIFF.	M2G24-001
1	7	CLOTH PLATE	26097E	1	1.12	LABEL "CAUTION"	26276E
4	6	WASHER, INTERNAL TOOTH	WWSI6	4	1.11	ISOLATOR MOUNT	26281
4	5	WASHER, BRASS	WWB5/32ID	1	1.10	V-BELT	ZX3833
4	4	SCREW, BRASS SLOTTED 6-40 x 3/8	SSTS85024	1	1.9	MOUNT, SPRING HOLDER	1975-520
1	3	CLOTH PLATE ASSY	26097C	1	1.8	RUBBER BAND	MMRBAND10
1	2	SEWING HEAD	SPEGEX521430	1	1.7	SPRING RETAINER	1975-519
1	1.18	SCREW,FILISTER HEAD,1/8-44	SSM185	1	1.6	CUTTER ASSEMBLY	1975-400M
1	1.17	HUB,HANDWHEEL,TAPE MOUNT	311-128	1	1.5	CUTTER & FOOTLIFT COMP	1975-400G6
1	1.16	SLEEVE,TAPE MOUNT	311-129	1	1.4	FOOT, EXTENDED	M1W19-001
1	1.15	PLATE, THROAT, BACKLATCH	M3G24-001	4	1.3	SCREW, SDC SET 1/4-20 x 1/2"	S5SS01032
1	1.14	MAIN FEED DOG	M2G24-002	1	1	SEWING HEAD PARTS	AP-26M-13S

## AP-26M-23 Sewing Head Detail

AAC Drawing Number 192324C Rev 1

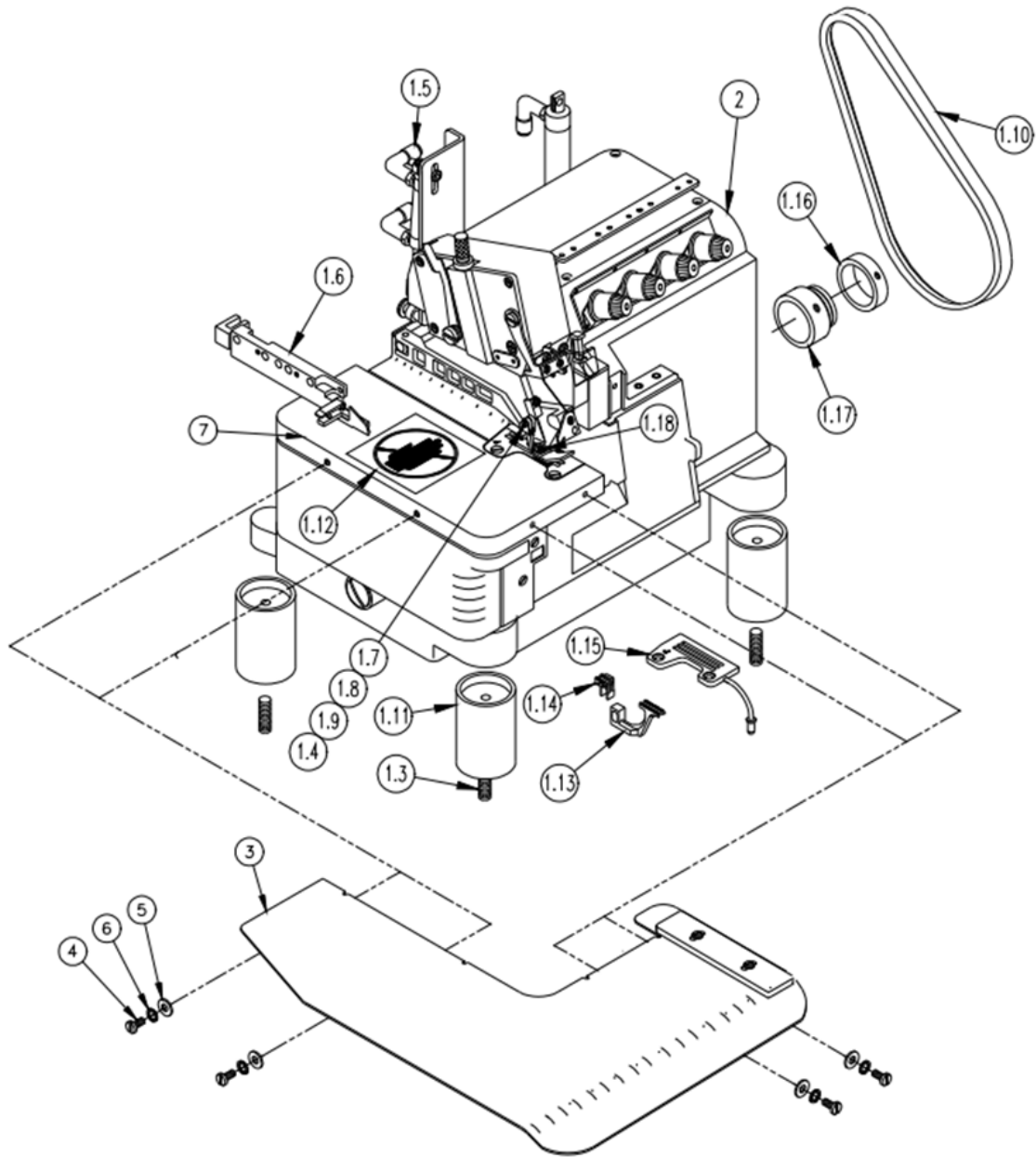

NO.	QTY	PART #	DESCRIPTION	NO.	QTY	PART #	DESCRIPTION
1	1	311-129	Tape Mounting	11	3	26149A	Isolator Holder
2	1	311-128	Tape Mounting	12	1	26149M	Isolator Spacer
3	1	1975-520	Spring Holder FT	13	1	26220A	Eye Mount
4	1	SSSS25032	Scr, Soc, Set	14	0	M2Y23-001	Feed Dog Main
5	1	SSM185	Scr, Fillister HD	15	0	M2Y23-002	Differential Feed
6	3	SSSS01032	Scr, Soc, Set	16	1	M1W19-001Y	Toe Modification
7	1	26276E	Caution Label	17	1	M3Y23-001	Throat Plate
8	1	1975-400M	Cutter Assembly	18	1	ZX3836	V Belt
9	1	1975-400S10	Cutter & Footlift Parts	19	1	MMRBAND10	Rubber Band
10	1	1975-519	Spring Holder	20	1	SYAM-8003G	Yamato Sewing HD

# 1975-400G6 Cutter & Foot lift, Pegasus Sewing Head

AAC Drawing Number 190478A Rev 7

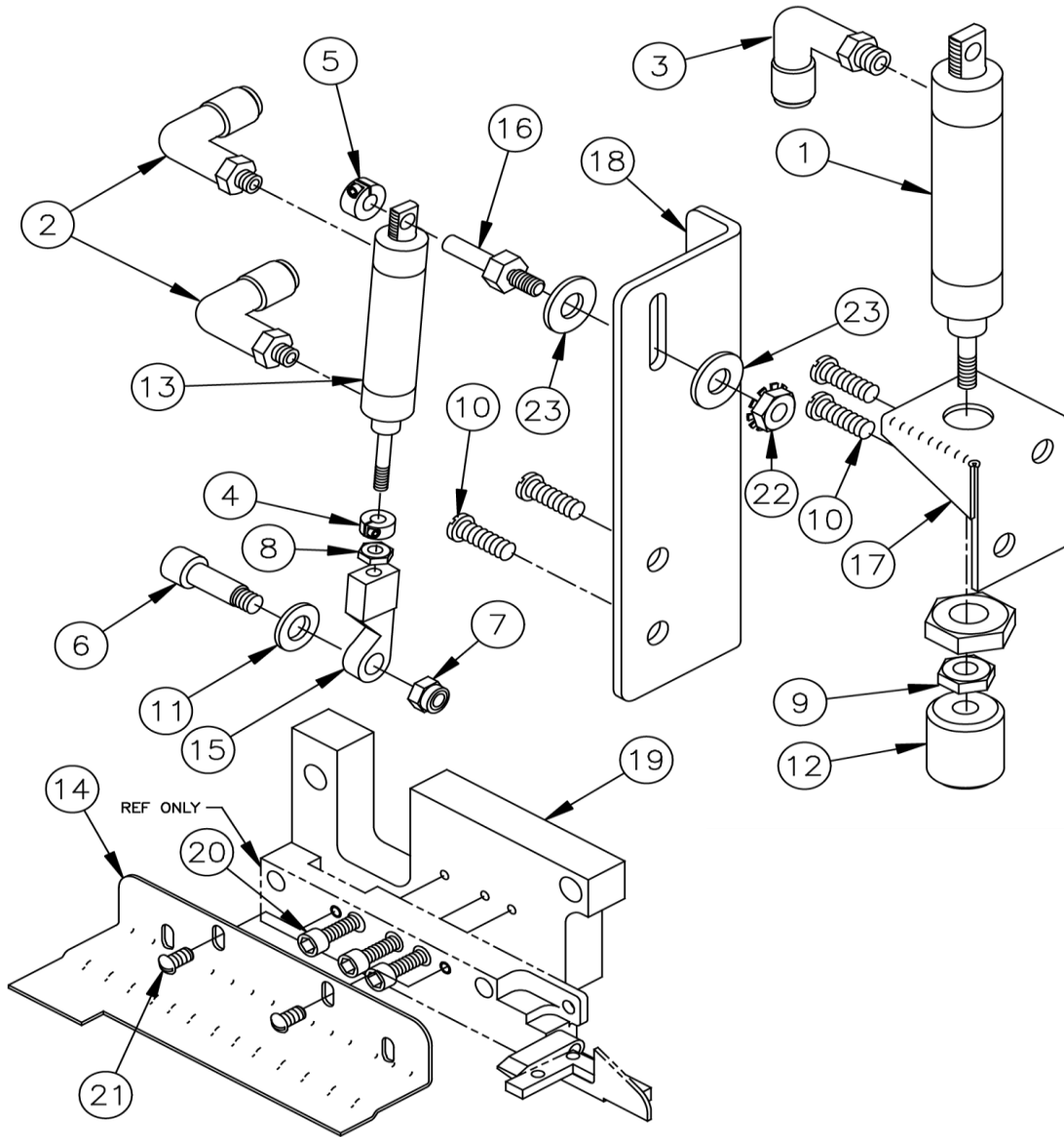

NO.	QTY	PART #	DESCRIPTION	NO.	QTY	PART #	DESCRIPTION
1	1	AAC7DP-1	Cylinder, Air	13	1	1975-213A	Cylinder, Air, Modified
2	2	AAQME-5-10	Quick Male Elbow	14	1	1975-244	Guard, Material
3	2	AAQME-5-8	Quick Male Elbow	15	1	1975-408	Link, Drive
4	1	CCCL3F	Collar, 3/16	16	1	1976-048	Stud, Cylinder Mount
5	1	CCSC33/16	3/16 Set Collar	17	1	1976-057B	Footlift Cylinder Mount
6	1	SSM4633	Shdr Scr So	18	1	1976-058	Cutter Cylinder Mount
7	1	NNE10-32	Elastic Nut	19	1	1976-059	Spacer, Cutter Body
8	1	NNH10-32	Nut, Hex 10-32	20	3	SSSC85024	Scr, Socket Cap, 6-40
9	1	NNJ1/4-28	Nut, Jam 1/4-28	21	0	SSTS85016	Scr, Truss Slotted, 6-40
10	4	SSCM6X10	Scr, Cheese Hd M6	22	1	NNK10-32	Kep Nut
11	1	WWFF1/4A	Felt Washer	23	2	WWFS10	SAE Flat Washer
12	1	11200	Bumper				

# 1975-400S Cutter & Foot lift, Yamato AZ8003H Sewing Head

AAC Drawing Number 190255A Rev 7

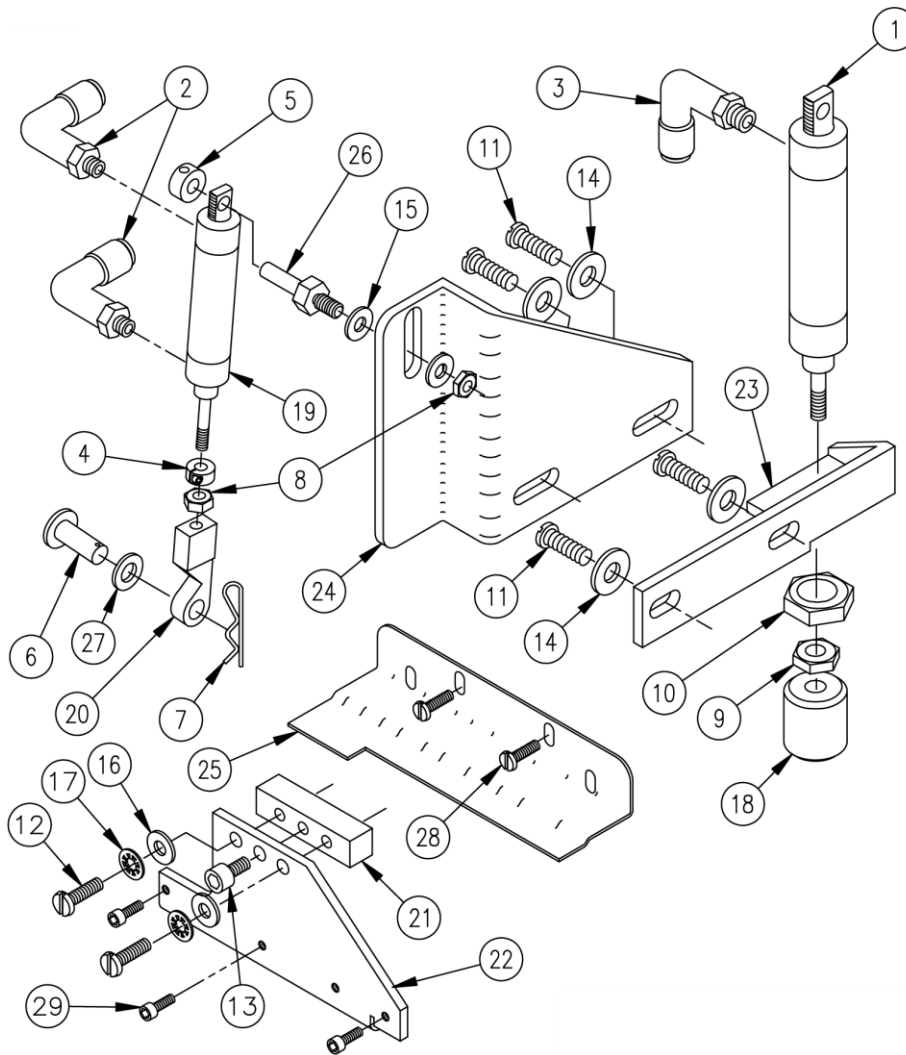

NO.	QTY	PART #	DESCRIPTION	NO.	QTY	PART #	DESCRIPTION
1	1	AAC7DP-1	Cylinder, air	16	2	WWFS6	Washer, SAE #6
2	2	AAQME-5-10	Quick male elbow	17	2	WWS16	Washer, Internal, #6
3	1	AAQME-5-8	Quick male elbow	18	1	11200	Bumper
4	1	CCCL3F	Collar, 3/16	19	1	1975-213A	Cylinder, Air, Modified
5	1	CCSC33/16	Set Collar, 3/16	20	1	1975-408	Link, Drive
6	1	MM92390A15	Clevis Pin	21	1	1975-440	Spacer, Mount
7	1	MM98335A04	Cotter Key	22	1	1975-441	Mount, Cutter Body
8	2	NNH10-32	Nut, Hex, 10-32	23	1	1975-442	Mount, Footlift Cylinder
9	1	NNJ1/4-28	Nut, Jam, 1/4-28	24	1	1975-443	Mount, Cutter Cylinder
10	1	NNJ5/8-18	Nut, Jam, 5/8-18	25	1	1975-445	Guard, Material
11	4	SSCM6X10	Scr, Cheese Head, M6	26	1	1976-048	Stud, Cylinder Mount
12	2	SSPSM4X20M	Scr, Pan Slot, M4x0.7	27	1	WWFF1/4A	Washer, Felt
13	1	SSSC98024	Scr, Socket Cap, 10-32	28	2	SSTS85016	Scr,Truss, 6-40 x 1/4
14	4	WWF1/4	Washer, Flat, 1/4	29	3	SSSC85024	Scr,Soc Cap,6-40 x 3/8
15	2	WWF10	Washer, Flat, #10				

# 1975-400S10 Cutter & Foot lift, Yamato AZ8003G Sewing Head

AAC Drawing Number 192025A Rev 3

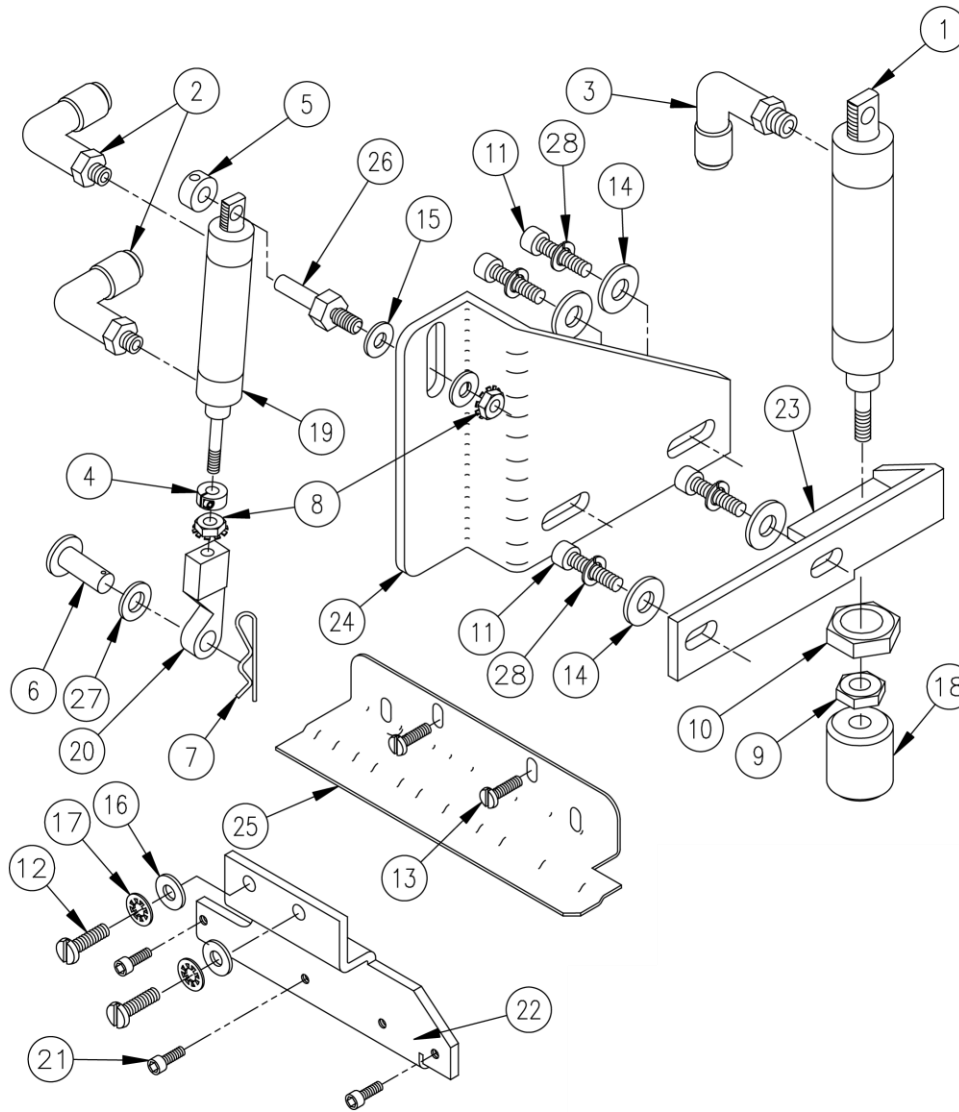

NO.	QTY	PART #	DESCRIPTION	NO.	QTY	PART #	DESCRIPTION
1	1	AAC7DP-1	Air Cylinder	15	2	WWF10	Washer, Flat #10
2	2	AAQME-5-10	Quick Male Elbow	16	2	WWFS6	Washer, SAE 6
3	1	AAQME-5-8	Quick Male Elbow	17	2	WWSI6	Washer, Int Lock, 6
4	1	CCCL3F	Collar, 3/16	18	1	11200	Bumper
5	1	CCSC33/16	3/16 Set Collar	19	1	1975-213A	Air Cylinder
6	1	MM92390A15	Clevis Pin	20	1	1975-408	Drive Link
7	1	MM98335A04	Cotter Key	21	3	SSSC85024	Scr,Soc, Cp 6-40x3/8
8	2	NNH10-32	Nut, Hex 10-32	22	1	1975-542	Mount, Cutter Body
9	1	NNJ1/4-28	Jam Nut, 1/4-28	23	1	1975-442	Mount, FtLift Cyl.
10	1	NNJ5/8-18	Jam Nut, 5/8-18	24	1	1975-443	Mount, Cutter Cyl
11	4	SSCM6X10	Scr, Chs, Hd, M6x10MM	25	1	1975-244	Material Guard
12	2	SSPSM4X10	Scr, Pn, Hd Sl	26	1	1976-048	Stud, Mount Cyl
13	2	SSTS85016	Scr, Trs Hd. 6-40x1/4	27	1	WWFF1/4A	Felt Washer
14	4	WWF1/4	Washer, Flat ¼	28	4	WWL1/4	Lock Washer

# 1975-400M Cutter Assembly

AAC Drawing Number 190330C

① ATTENTION / ATENCIÓN  
MAKE SURE THAT CUTTER SHAFT DOES NOT BIND INSIDE BODY.  
*ASEGURESE QUE EL EJE NO SE ATASCA DENTRO DEL CUERPO.*

② ASSEMBLE LEAVING SCREWS SLIGHTLY LOOSE ON LOWER CUTTER (SCREWS NOT SHOWN FOR CLARITY)  
*ARME DEJANDO LOS TORNILLOS FLOJOS EN EL CORTADOR DE ABAJO. (LOS TORNILLOS NO SE MUESTRAN POR CLARIDAD.)*

③ TIGHTEN SET COLLAR TO HOLD SPRING AT 41.15mm WITH UPPER CUTTER PRESSING AGAINST LOWER CUTTER  
*APRIETE EL COLLAR PARA MANTENER EL RESORTE A 41.15mm CON EL CORTADOR DE ARRIBA PRESIONANDO CONTRA EL CORTADOR DE ABAJO.*

④ SET SHEAR AT .05mm AND TIGHTEN SCREWS ON LOWER CUTTER UNTIL IT IS LOCKED IN PLACE  
*FIJE EL CORTE A .05mm Y APRIETE BIEN LOS TORNILLOS EN EL CORTADOR DE ABAJO.*

**CUTTER ADJUSTMENT INSTRUCTIONS**

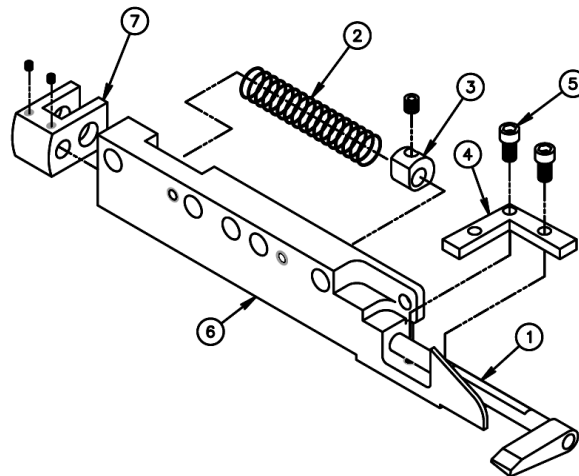

NO	QTY	PART #	DESCRIPTION	NO	QTY	PART #	DESCRIPTION
1	1	1976-100	UPPER CUTTER ASSY	5	2	SSSC70016	SCREW, SOCKET, CAP4-40 X .25
2	1	RRLC046CD15S	SPRING	6	1	1975-432	CUTTER BODY
3	1	1976-002	RETAINER	7	1	1975-407	CLEVIS
4	1	1976-024	LOWER CUTTER				

## Cutter Adjustments

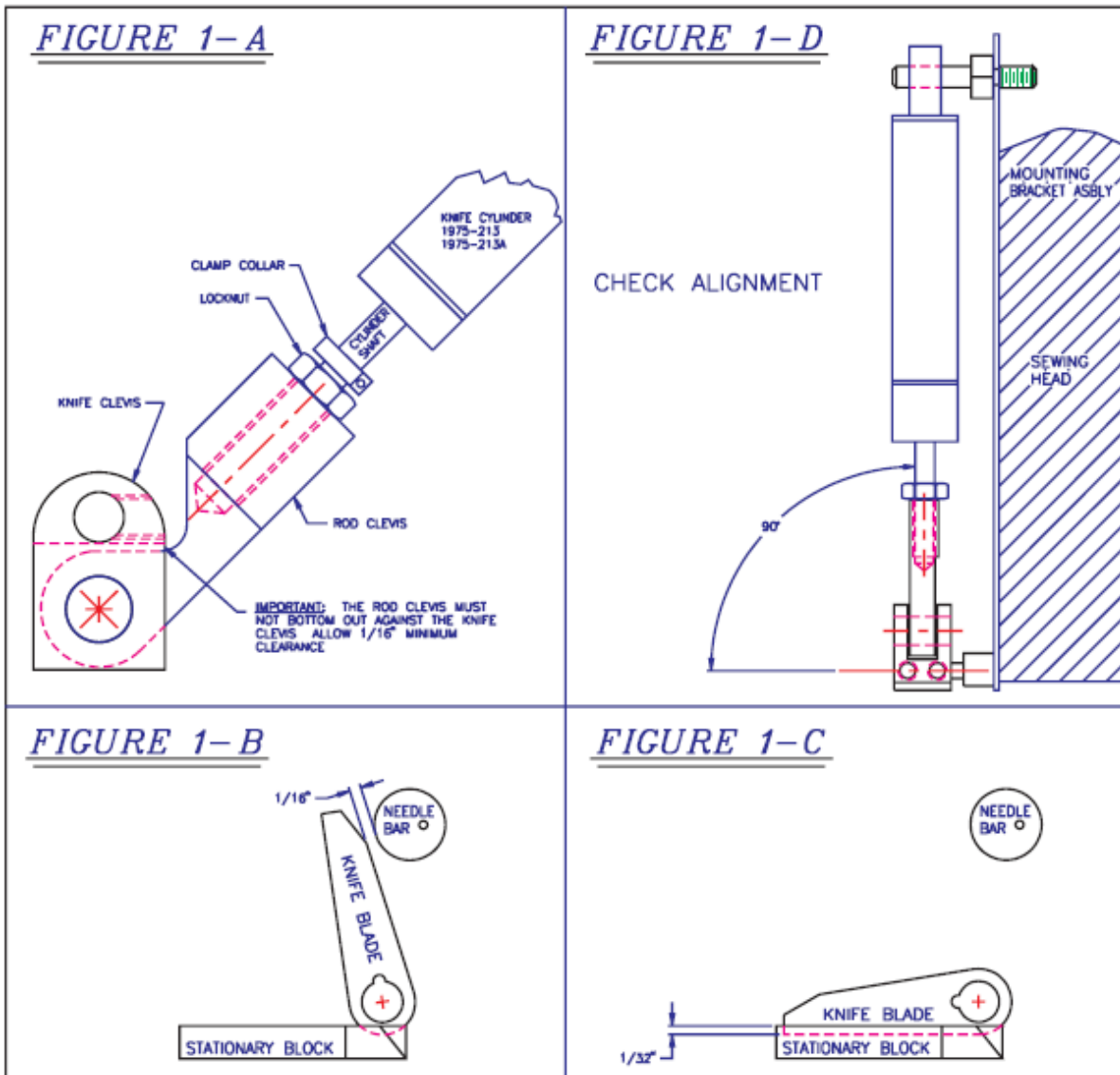

### Cutter Adjustments

With the Cutter air cylinder fully extended, clearance must be maintained (Fig 1-A) between the Cutter clevis and the rod clevis to prevent breakage of the air cylinder, Cutter body or air cylinder mounting bracket.

While maintaining this clearance, rotate the Cutter blade and rod in the Cutter clevis to its most vertical position being careful not to interfere with needle bar movement (Fig 1-B).

After checking alignment (Fig 1-D), tighten the set screws in the Cutter clevis securely.

Retract the Cutter cylinder to check the down stroke of the Cutter blade (Fig 1-C). The rod clamp collar may be moved to limit down travel

**See Maintenance Section for additional details.**

# Atlanta Attachment Company (AAC) Statement of Warranty

## Manufactured Products

Atlanta Attachment Company warrants manufactured products to be free from defects in material and workmanship for a period of eight hundred (800) hours of operation or one hundred (100) days whichever comes first. Atlanta Attachment Company warrants all electrical components of the Serial Bus System to be free from defects in material or workmanship for a period of thirty-six (36) months.

## Terms and Conditions:

- AAC Limited Warranty becomes effective on the date of shipment.
- AAC Warranty claims may be made by telephone, letter, fax or e-mail. All verbal claims must be confirmed in writing.
- AAC reserves the right to require the return of all claimed defective parts with a completed warranty claim form.
- AAC will, at its option, repair or replace the defective machine and parts upon return to AAC.
- AAC reserves the right to make the final decision on all warranty coverage questions.
- AAC warranty periods as stated are for eight hundred (800) hours or one hundred (100) days whichever comes first.
- AAC guarantees satisfactory operation of the machines on the basis of generally accepted industry standards, contingent upon proper application, installation and maintenance.
- AAC Limited Warranty may not be changed or modified and is not subject to any other warranty expressed or implied by any other agent, dealer, or distributor unless approved in writing by AAC in advance of any claim being filed.

## What Is Covered

- Electrical components that are not included within the Serial Bus System that fail due to defects in material or workmanship, which are manufactured by AAC are covered for a period of eight hundred (800) hours.
- Mechanical parts or components that fail due to defects in material or workmanship, which are manufactured by AAC.
- Purchased items (sewing heads, motors, etc.) will be covered by the manufacturers (OEM) warranty.
- AAC will assist in the procurement and handling of the manufacturers (OEM) claim.

## What Is Not Covered

- Parts that fail due to improper usage, lack of proper maintenance, lubrication and/or modification.
- Damages caused by; improper freight handling, accidents, fire and issues resulting from unauthorized service and/or personnel, improper electrical, plumbing connections.
- Normal wear of machine and parts such as Conveyor belts, "O" rings, gauge parts, cutters, needles, etc.
- Machine adjustments related to sewing applications and/or general machine operation.
- Charges for field service.
- Loss of time, potential revenue, and/or profits.
- Personal injury and/or property damage resulting from the operation of this equipment.



## Declaración de Garantía

### Productos Manufacturados

Atlanta Attachment Company garantiza que los productos de fabricación son libres de defectos de material y de mano de obra durante un periodo de ochocientos (800) horas de operación o cien (100) días cual llegue primero. Atlanta Attachment Company garantiza que todos los componentes del Serial bus son libres de defectos de material y de mano de obra durante un periodo de treinta y seis (36) meses.

### Términos y Condiciones:

- La Garantía Limitada de AAC entra en efecto el día de transporte.
- Reclamos de la Garantía de AAC pueden ser realizados por teléfono, carta, fax o correo electrónico. Todo reclamo verbal tiene que ser confirmado vía escrito.
- AAC reserva el derecho para exigir el retorno de cada pieza defectuosa con un formulario de reclamo de garantía.
- AAC va, según su criterio, reparar o reemplazar las máquinas o piezas defectuosas devueltas para AAC.
- AAC reserva el derecho para tomar la decisión final sobre toda cuestión de garantía.
- Las garantías de AAC tiene una validez de ochocientas (800) horas o cien (100) días cual llega primero.
- AAC garantiza la operación satisfactoria de sus máquinas en base de las normas aceptadas de la industria siempre y cuando se instale use y mantenga de forma apropiada.
- La garantía de AAC no puede ser cambiado o modificado y no está sujeto a cualquier otra garantía implicado por otro agente o distribuidor menos al menos que sea autorizado por AAC antes de cualquier reclamo.

### Lo Que Está Garantizado

- Componentes eléctricos que no están incluidos dentro del sistema Serial Bus que fallen por defectos de materiales o de fabricación que han sido manufacturados por AAC son garantizados por un periodo de ochocientas (800) horas.
- Componentes mecánicos que fallen por defectos de materiales o de fabricación que han sido manufacturados por AAC son garantizados por un periodo de ochocientas (800) horas.
- Componentes comprados (Motores, Cabezales, ) son protegidos debajo de la garantía del fabricante.
- AAC asistirá con el manejo de todo reclamo de garantía bajo la garantía del fabricante.

### Lo Que No Está Garantizado

- Falla de repuestos a la raíz de uso incorrecto, falta de mantenimiento, lubricación o modificación.
- Daños ocurridos a raíz de mal transporte, accidentes, incendios o cualquier daño como resultado de servicio por personas no autorizados o instalaciones incorrectas de conexiones eléctricas o neumáticas.
- Desgaste normal de piezas como correas, anillos de goma, cuchillas, agujas, etc.
- Ajustes de la máquina con relación a las aplicaciones de costura y/o la operación en general de la máquina.
- Gastos de Reparaciones fuera de las instalaciones de AAC
- Pérdida de tiempo, ingresos potenciales, y/o ganancias.
- Daños personales y/o daños a la propiedad como resultado de la operación de este equipo.