



Model

411F

Revision 2 Updated October 10, 2023(wr)

Operational Manual 411F Workstation

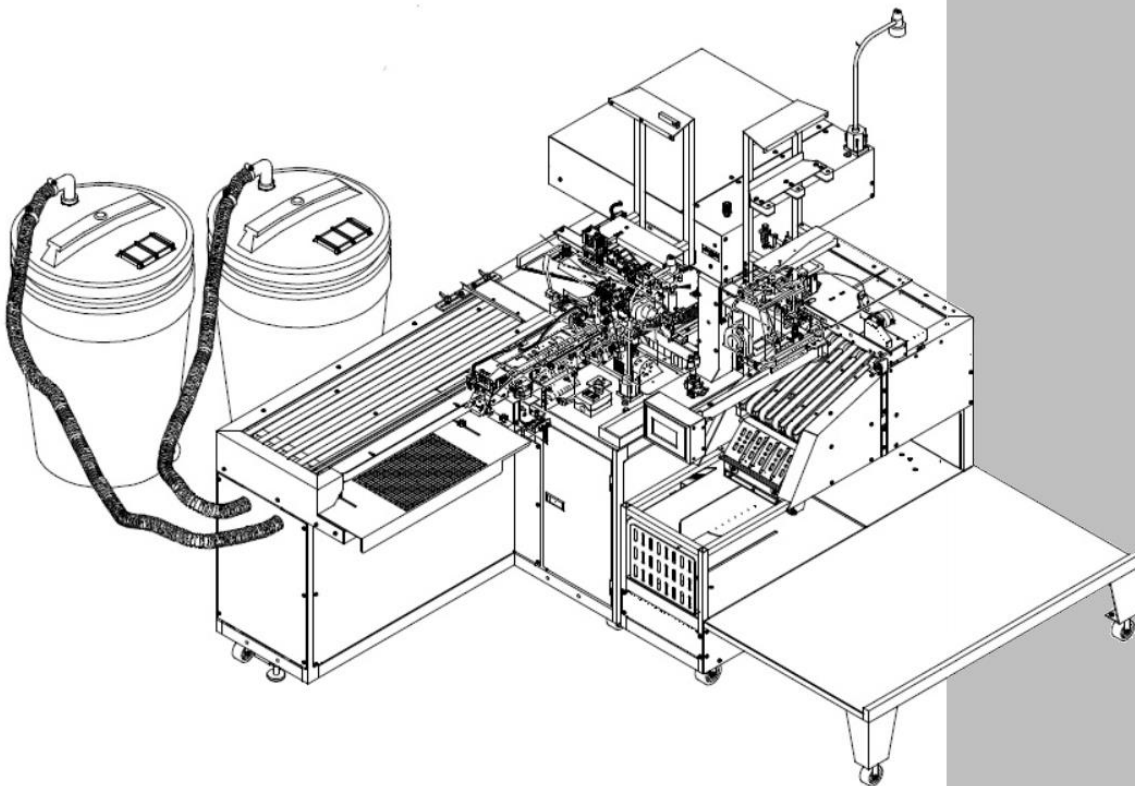

362 Industrial Park Drive
Lawrenceville, GA 30046
+1 (770-963) 7369
www.atlatt.com

Atlanta Attachment Company, Inc.

Confidential and Proprietary Information

The materials contained herein are confidential and proprietary information of Atlanta Attachment Company. In addition to any confidentiality and non-disclosure obligations that currently exist between you and Atlanta Attachment Company, your use of these materials serves as an acknowledgment of the confidential and proprietary nature of these materials and your duty not to make any unauthorized use or disclosure of these materials.

All materials contained herein are additionally protected by United States Copyright law and may not be used, disclosed, reproduced, distributed, published, or sold without the express written consent of Atlanta Attachment Company, which consent may be withheld in Atlanta Attachment Company's sole discretion. You may not alter or remove any copyright, trademark, or other notice from copies of these materials.

IMPORTANT

It is important to read and understand the information contained within this manual before attempting to operate the machine. Atlanta Attachment Co., Inc. shall not be held liable for damage resulting from misuse of the information presented within, and reserves the right to change the information contained within, without prior notification.

Patents & Patents Pending

The sale of this product does not sell or otherwise transfer any license or other rights under any U.S. Patent or other corresponding foreign patent.

This equipment is manufactured under one or more of the following patents:

4,280,421 • 4,432,294 • 4,466,367 • 4,644,883 • 5,134,947 • 5,159,889 • 5,203,270 •
5,373,798 • 5,437,238 • 5,522,332 • 5,524,563 • 5,562,060 • 5,634,418 • 5,647,293
•5,657,711 • 5,743,202 • 5,865,135 • 5,899,159 • 5,915,319 • 5,918,560 • 5,924,376
•5,979,345 • 6,035,794 • 6,055,921 • 6,202,579 • 6,279,869 • 6,295,481 • 6,494,225
•6,523,488 • 6,574,815 • 6,802,271 • 6,834,603 • 6,968,794 • 6,994,043 • 7,543,364
•7,574,788 • 7,647,876 • 7,735,439

Foreign Patents: 9-520,472 • 0,537,323 • 92,905,522.6 • 96,936,922.2 • 2,076,379 •
2,084,055

Other U.S. and Foreign Patents Pending.

Contents

CONFIDENTIAL AND PROPRIETARY INFORMATION	0
CONTENTS.....	1
SAFETY INSTRUCTION	0
Important Notices.....	3
Maintenance	5
1. INSTALLATION	7
1.1. OPTIONS & CLASSES.....	7
1.2. TECHNICAL DATA	8
1.3. PRODUCTION	8
1.4. FOOT PRINT	ERROR! BOOKMARK NOT DEFINED.
1.5. MACHINE IDENTIFICATION LABEL.....	8
1.6. INSTALLATION & SET UP.....	9
1.7. PARTS AND COMPONENTS	9
1. Leveling.....	10
2. Sewing Head.....	10
A. V-belt.....	10
B. Lubrication	10
3. Thread Detectors.....	11
4. Touch Screen.....	12
5. Power Supply	12
6. Air Supply.....	12
7. Folder.....	13
8. Top Conveyor.....	13
9. Bundle Table	13
10. Waste System	13
1.8. POWER “ON”	13
1. Power Button.....	13
2. Electric Eyes	14
3. Stepping Motors	14
4. Pedals	14
A. Hemmer Pedal	14
B. Stacker Pedal.....	14
C. Seamer Pedals	14
1.9. INTERIM STORAGE	14
2. OPERATOR INSTRUCTIONS	15
2.1. GENERAL DESCRIPTION.....	15
2.2. INDIVIDUAL COMPONENTS.....	16
1. Power Switch	17
A. Power On.....	17
B. Emergency Stop	17
2. Touch Screen.....	17
3. Hemmer Upper Conveyor.....	17
4. Hemmer Lower Conveyor.....	17
5. Hemmer Folder	17
6. Pedals	18
A. Hemmer Sewing Head.....	18
B. Push Tray Pedal	18
C. Seamer Sew	18
D. Seamer Presser foot.....	18
7. Edge Trim.....	18
8. Edge Guide (Optional).....	18

9.	Hemmer Sewing Head	18
10.	Thread Detectors.....	19
A.	Looper Thread Sensor.....	19
B.	Needle Thread Sensor.....	19
11.	Fold In Half Station.....	19
12.	Seamer Sewing Head.....	19
13.	Sleeve Stacker	19
14.	Waste System	20
2.3.	TOUCH-SCREEN.....	20
1.	General Operation.....	20
2.	Available Menus.....	22
READY	23	
START	23	
SET UP.....	23	
HEMMER MANUAL.....	24	
SEAMER MANUAL.....	24	
STYLE	24	
PIECE COUNTER	25	
2.4.	SEWING PREPARATION.....	25
1.	Operation Description.....	25
2.	Hemmer Preparation	25
A.	Looper Thread Sensor.....	26
B.	Needle Thread Sensor.....	26
3.	Seamer Preparation	29
4.	Seamer Sew-off (Repair Mode).....	30
2.5.	SEWING SEQUENCE	31
2.6.	MAINTENANCE	33
1.	General Safety Instructions	33
2.	Preparation.....	33
3.	Preventive Maintenance 8 Hrs.....	34
3.	SERVICE INSTRUCTIONS.....	35
3.1.	LOCK OUT/TAG OUT PROGRAM	35
3.2.	MECHANICAL	36
1.	Hemmer Adjustments.....	36
A.	Hem Cutting Width.....	36
B.	Sewing Width	38
C.	Stitch Length	47
D.	Needle distance	47
2.	Folding Station Adjustment.....	48
A.	Folding Plate / Air Folder Adjustment	48
B.	Air Jet/Clamp Plate Adjustment	49
C.	Hem Alignment Guide Pins Adjustment.....	50
D.	Bottom Ply Alignment Jet Adjustment.....	50
E.	Skid Plate Adjustment.....	50
F.	Transport 1 Clamp Cylinder.....	51
G.	Transport 1 Cylinder.....	51
H.	Transport 2 Clamp Cylinder.....	51
I.	Transport 2 Cylinder:	51
J.	Proximity Switch Adjustments.....	52
K.	Rotate cylinder function and adjustment.....	52
L.	Seam Guide Wheels	52
M.	Flow controls.....	52
N.	Air Regulators Top Cabinet.....	53
3.	Seamer Adjustment.....	54
A.	Seamer Air Supply Setting:.....	54
B.	Tension Opener:	54
C.	Seamer Conveyor Height Adjustment	54

D.	Seamer Conveyor Spring Pressure	54
E.	Front Belt Feed Conveyor	55
F.	Backlatch.....	Error! Bookmark not defined.
G.	Chain Trimmer:	56
H.	Seamer Waste System:	57
I.	Vacuum Ejector Assembly Maintenance:	57
4.	Stacker	58
A.	Trap Door adjustment	58
B.	Transfer wheels	58
C.	Stacker door adjustment	58
D.	Eye adjustments and positions	58
E.	Flow controls	58
3.3.	PNEUMATIC	59
1.	Air Filters	59
2.	Pressure Regulator	59
3.	Solenoid Valve Stacking Manifold	60
4.	Air Pressure Switch	60
5.	Waste Venturi.....	61
6.	Blowers	61
A.	Front of Top Conveyor.	61
B.	Front of the Trimming Knife.	61
C.	On the side of the Top conveyor.....	61
D.	Fold In Half Entrée	61
E.	Seamer Guide Wheels	61
7.	Sophie Air Jet.....	62
A.	Clamp plate	62
B.	Bottom Ply.....	62
C.	Seamer.....	62
8.	Cylinders	63
A.	Hemmer Cylinders	63
B.	Fold in Half Cylinder.....	63
C.	Seamer Cylinders.	64
D.	Stacker Cylinder's	65
3.4.	ELECTRICAL.....	66
1.	Ground	66
2.	Main Circuit Breaker	66
3.	Main Power Contactor.	66
4.	Thread Break Detectors.	67
A.	Looper Thread Sensor	67
B.	Adjustment.	67
C.	Needle Thread Sensor	67
5.	Stepping Motors	68
A.	Hemmer Sewing Head Puller Control Box.....	69
B.	Hemmer & Seamer Conveyors Control Box	70
6.	Sewing Motor Control Boxes	72
A.	Efka	72
B.	Panasonic	74
7.	Electric Eyes	76
A.	Eye Sensor Adjustment	76
B.	Reflective Tape Maintenance	76
C.	Eyes Functions	77
8.	Operation Sequence.....	80
A.	Hemmer	80
B.	Fold in Half	81
C.	Transport.....	81
D.	Seamer.....	82
E.	Stacker	83
3.5.	SERIAL BUS	84
1.	Technical Data	84

2.	Serial Bus Identification Label	84
3.	Models	84
4.	Concept Wiring.....	85
5.	Parts and Components.....	86
6.	Power Supply	87
7.	Wire Cable	87
A.	Cable Connection	87
8.	Connections Ports	88
9.	Color LED.....	89
A.	Bi color LED	89
B.	The tri-color LED.....	89
10.	Touch Screen.....	90
A.	Calibration.....	90
B.	Calibrating 003 and older Touch Screen	92
C.	Installation.....	93
11.	Modules.....	94
A.	Program Module...4080-150.....	94
B.	Data Module...4080-930.....	94
C.	Output Module...4080-140.....	94
D.	Quad Opto Input Module...4080-120.....	94
E.	Input Module...4080-110	94
F.	Single Output Module ...4080-160	94
G.	Output Module ...4080-130.....	94
12.	Module Replacement.....	95
A.	Replacement of a Single Module	95
B.	Replacement of Memory Modules	95
13.	Program Update	99
A.	Using a New Program Module	99
B.	Using a New Program Module Updating Machine Type and Memory	100
C.	Using a New Program Module to update Original Module	100
D.	Using a New Program and Additional Modules	101
E.	Update a -004 Screen with a New Program Module	101
F.	Update a -004 Screen with New Program Module that has not had a Revision change	102
G.	Update a -004 Screen with New Program using a Laptop	103
14.	Technical Screens	105
A.	Introduction	105
B.	Advanced Set Up,	106
C.	Advanced Manual	113
D.	Style	114
15.	Expiration Count 911	115
A.	Unlock Procedure 004 + 4A Screens	115
B.	Unlock on old Screens	116
3.6.	MAINTENANCE	118
1.	General Safety Instructions	118
2.	Preventive Maintenance 40 Hrs.....	119
3.	Preventive Maintenance 960 Hrs.....	120
4.	Serial Bus Preventive Maintenance	121
3.7.	TROUBLESHOOTING	122
1.	Screen Messages.....	122
2.	Hemmer Troubleshooting	123
3.	Fold-In-Half Troubleshooting	124
4.	Seamer Troubleshooting	125
5.	General Troubleshooting	127
6.	Efka Controller Error.....	130
A.	Flow Chart EFKA Error E1.....	131
7.	Panasonic D9 Controller Errors.....	132
5.	ASSEMBLY DRAWINGS & PARTS LISTS.....	133

Atlanta Attachment Company (AAC) Statement of Warranty	135
Manufactured Products	135
Terms and Conditions:	135
What Is Covered	135
What Is Not Covered	135
DECLARACIÓN DE GARANTÍA	136
Productos Manufacturados.....	136
Términos y Condiciones:	136
Lo Que Está Garantizado	136
Lo Que No Está Garantizado	136
TRAINING	137

Safety Instruction



This part of the Instruction Material is provided for the safe use of your equipment. It contains important information to help work safely with the unit and describes the dangers inherent in machinery. Some of these dangers are obvious, while others are less evident.

Mandatory Information

All persons operating and/or working on the Workstation should read and understand all parts of the Safety Instructions. This applies, in particular, for persons who only operate and/or work on the unit occasionally (e.g. for maintenance and repair). Persons who have difficulty reading must receive particularly thorough instruction.

Scope of the Instruction Material

The Instruction Material comprises:

Safety information

Operator Instructions

Electrical and Pneumatic diagrams

And may also include a list of recommended spare parts

Instruction Manual(s) for components made by other manufacturers

The layout and installation diagram containing information for installation

Intended Use

Our machines are designed and built in line with the state of the art and the accepted safety rules. However, all machines may endanger the life and limb of their users and/or third parties and be damaged or cause damage to other property, particularly if they are operated incorrectly or used for purposes other than those specified in the Instruction Manual.

Exclusion of Misuse



Non-conforming uses include, for example, using the equipment for something other than it was designed for, as well as operation without duly installed safety equipment. The risk rests exclusively with the end user.

Conforming use of the machine includes compliance with the technical data, information, and regulations in all parts of the complete Instruction Material, as well as compliance with the maintenance regulations. All local safety and

accident prevention regulations must also be observed.

Liability

The machine should only be operated when in perfect working order, with due regard for safety and the potential dangers, as well as in accordance with the Instruction Material. Faults and malfunctions capable of impairing safety should be remedied immediately. We cannot accept any liability for personal injury or property damage due to operator errors or non-compliance with the safety instructions contained in this booklet. The risk rests exclusively with the end user.

The Instruction Material should always be kept near the machine so that it is accessible to all concerned.

The local, general, statutory, and other binding regulations on accident prevention and environmental protection must also be observed in addition to the Instruction Material. The operating staff must be instructed accordingly. This obligation also includes the handling of dangerous substances and provision/use of personal protective equipment.

The Instruction Material should be supplemented by instructions, including supervisory and notification duties with due regard for special operational features, such as the organization of work, work sequences, the personnel deployed, etc.

Safety

The personnel's awareness of the dangers and compliance with the safety regulations should be checked at irregular intervals.

Choice and Qualification of Personnel

Ensure that work on the machine is only carried out by reliable persons who have been appropriately trained for such work - either within the company, by our field staff or at our office - and who have not only been duly appointed and authorized but are also fully familiar with the local regulations. Work on the machine should only be carried out by skilled personnel, under the management and supervision of a duly qualified engineer.

This not only applies when the machine is used for production, but also for special work associated with its operation (start-up and maintenance), especially when it concerns work on the hydraulic or electrical systems, as well as on the software/serial bus system.

Training

Everyone working on or with the machine should be duly trained and informed with regard to correct use of the safety equipment, the foreseeable dangers which may arise during operation of the machine and the safety precautions to be taken. In addition, the personnel should be instructed to check all safety mechanisms at regular intervals.

Responsibilities

Clearly define exactly who is responsible for operating, setting-up, servicing and repairing the machine. Define the responsibilities of the machine operator and authorize him to refuse any instructions by third parties if they run contrary to the machine's safety. This applies in particular for the operators of machines linked to other equipment. Persons receiving training of any kind may only work on or with the machine under the constant supervision of an experienced operator. Note the minimum age limits permitted by law.

A Word to the Operator

The greatest danger inherent in our machines: is that of fingers, hands or loose clothing being drawn into a machine by live, coasting, or rotating tools or assemblies or of being cut by sharp tools or burned by hot elements.

Always be conscious of these dangers!

Safety Equipment on the Machines



All machines are delivered with safety equipment, which shall not be removed or bypassed during operation.

The correct functioning of safety equipment on machines and systems should be checked every day and before every new shift starts, after maintenance and repair work, when starting up for the first time and when restarting (e.g. after prolonged shutdowns).

If safety equipment has to be dismantled for setting-up, maintenance or repair work, such safety equipment shall be replaced and checked immediately upon completing the maintenance or repair work.

All protective mechanisms shall be fitted and fully operational whenever the machine is at a standstill or if it has been shut down for a longer period of time.

Damage

If any changes capable of impairing safety are observed in the machine or its mode of operation, such as malfunctions, faults or changes in the machine or tools, appropriate steps must be taken immediately, the machine switched off and a proper lockout tagout procedure followed. The machine should be examined for obvious damage and defects at least once per

Safety

shift. Damage found shall be immediately remedied by a duly authorized person before resuming operation of machine.

The machine should only be operated when in perfect working order and when all protective mechanisms and safety equipment, such as detachable protective mechanisms, emergency STOP systems, etc. are in place and operational.

Faults or Errors

The machine must be switched off and all moving or rotating parts allowed to come to a standstill and secured against accidental restart before starting to remedy any faults or errors.

Signs on the Machine

Safety and danger signs on the machine should be observed and checked at regular intervals to ensure that they are complete and undamaged. They should be clearly visible and legible at all times.

Clothing, Jewelry, Protective Equipment

Long loose hair, loose-fitting clothes, gloves and jewelry, including rings, should be avoided in order to avoid injuries due to being caught, drawn in and wound up inside the machine.

Protective Eyewear

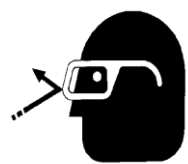

Protective eyewear that has been tested by the local authorities should be worn whenever there is a possibility of loose or flying objects or particles such as when cleaning the machine with compressed air.

Tools

Always count the number of tools in your possession before starting work on the machine. This will allow you to check that no tools have been left behind inside the machine. Never leave a tool in the machine while working.

Oils, Lubricants, Chemicals

NOTEote the applicable safety regulations for the product used.

No Smoking, Fire, Explosion Hazard

Smoking and open flame (e.g. welding work) should be prohibited in the production area due to the risk of fire and explosions.

Workplace

A clear working area without any obstructions whatsoever is essential for safe operation of the machine. The floor should be level and clean, without any waste.

The workplace should be well lit, either by the general lighting or by local lights.

Emergency STOP

The emergency STOP buttons bring all machine movements to a standstill. Make sure you know exactly where they are located and how they work. Try them out. Always ensure easy access to the nearest emergency STOP button while working on the machine.

First Aid

1. Keep calm even when injured.
2. Clear the operator from the danger zone. The decision of what to do and whether to seek additional assistance rests entirely with you, particularly if someone has been trapped.
3. Give First Aid. Special courses are offered by such organizations as the employers' liability insurance association. Your colleagues should be able to rely on you and vice versa.
4. Call an ambulance. Do you know the telephone numbers for the ambulance service, police and fire service?

Important Notices

Reporting and Fighting Fires

Read the instructions posted in the factory with regard to reporting fires and the emergency exits. Make sure you know exactly where the fire extinguishers and sprinkler systems are located and how they are operated. Pass on the corresponding information to the firemen when they arrive. Ensure there are enough signs to avoid fire hazards.

The following fire extinguishers may be used:

- Dry powder extinguishers, ABC fire-extinguishing powder.
- Carbon dioxide fire extinguishers to DIN 14461 for electronic components. Great care must be exercised when using carbon dioxide fire extinguishers in confined, badly ventilated rooms (see DIN 14406 and 14270).

Isolate the machine from the power supply if a fire breaks out. Do not use water on burning electrical parts until it is absolutely certain that they have been completely disconnected from the power supply. Burning oils, lubricants, plastics, and coatings on the machine can give off gases and vapors that may be harmful to your health.

A qualified person should be consulted to repair the damage after a fire.

Electrical Power Supply

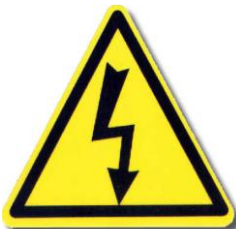

Before undertaking any maintenance or repair work on the machine, switch off the electrical power to the machine at the main source and secure it with a padlock so that it cannot be switched on again without authorization.

In practice, this may mean that the technician, electrician, and operator all attach their own padlock to the master switch simultaneously so that they can carry out their work safely. Locking extension plates should be available for multiple locks if required. The primary purpose for a lockout/tagout

procedure is to protect workers from injury caused by unexpected energizing or start-up of equipment.

Energy sources (electrical/pneumatic/hydraulic, etc.) for the equipment shall be turned off or disconnected and the switches locked or labeled with a warning tag. It is the responsibility of the employer to establish control procedures. Follow lockout/tagout procedures before, setup and/or any service or maintenance work is performed, including lubrication, cleaning or clearance of jams.

Caution: The machine is still not completely de-energized even when the master switch is off.

- Electricity - The machine is always isolated from the electrical power supply whenever the master switch has been switched off. However, this does not apply for the power supply in the control cabinet, nor for equipment that does not draw its power via the master switch.

- Pneumatic / hydraulic energy - Almost all our machines carry compressed air. In addition to switching off the master switch, the air supply must also be disconnected, and the machine checked to ensure it is depressurized before starting any work on the machine; otherwise the machine may execute uncontrolled movements.

- Kinetic energy - Note that some motors or spindles, for example, may continue to run or coast run on after being switched off.

- Potential energy - Individual assemblies may need to be secured if necessary for repair work.

Safety

Delivery of the Machine/Packaging

Note any markings on the packaging, such as weights, lifting points and special information. Avoid temperature fluctuations. Condensation may damage the machine.

Transport Damage

The packaging and machine must immediately be examined for signs of damage in transit. Such damage must be reported to the shipper/transporter within the applicable time limits. Contact Atlanta Attachment Company and/or your transport insurer immediately, if signs of damage are visible. Never operate a damaged machine.

Interim Storage

If the machine has to be stored temporarily, it must be oiled or greased and stored in a dry place where it is protected from the weather in order to avoid damage. A corrosion-inhibiting coating should be applied if the machine has to be stored for a longer period of time and additional precautions taken to avoid corrosion.

Transporting the Machine

Disconnect the machine from all external connections and secure any loose assemblies or parts. Never step under a suspended load. When transporting the machine or assemblies in a crate, ensure that the ropes or arms of a forklift truck are positioned as close to the edge of the crate as possible. The center of gravity is not necessarily in the middle of the crate. Note the accident prevention regulations, safety instructions and local regulations governing transport of the machine and its assemblies.

Only use suitable transport vehicles, hoisting gear and load suspension devices that are in perfect working order and of adequate carrying capacity. Transport should only be entrusted to duly qualified personnel.

Never allow the straps to rest against the machine enclosure and never push or pull sensitive parts of the machine. Ensure that the load is always properly secured. Before or immediately after loading the machine, secure it properly and affix corresponding warnings.

All transport guards and lifting devices must be removed before the machine is started up again. Any parts that are to be removed for transport must be carefully refitted and secured before the machine is started up again.

Workplace Environment

Our machines are designed for use in enclosed rooms: Permissible ambient temperature approx. 5 - 40 °C (40 - 104 °F). Malfunctions of the control systems and uncontrolled machine movements may occur at temperatures outside this range.

Protect against climatic influences, such as electrostatic charges, lightning strikes, hail, storm damage, high humidity, salinity of the air in coastal regions.

Protect against influences from the surroundings: no structure-borne vibrations, no grinding dust, or chemical vapors.

Protect against unauthorized access.

Ensure that the machine and accessories are set up in a stable position.

Ensure easy access for operation and maintenance (Instruction Manual and layout diagram); also verify that the floor is strong enough to carry the weight of the machine.

Local Regulations

Particular attention must be paid to local and statutory regulations, etc. when installing machines and the plant (e.g. with regard to the specified escape routes). Note the safety zones in relation to adjacent machines.

Safety

Maintenance

General Safety Instructions

The machine shall be switched off, come to a standstill, and be secured so that it cannot be switched on again inadvertently before starting any maintenance work whatsoever. Use proper lockout/tagout procedures to secure the machine against inadvertent startup.

Remove any oil, grease, dirt, and waste from the machine, particularly from the connections and screws, when starting the maintenance and/or repair work. Do not use any corrosive-cleaning agents. Use lint-free rags.

Retighten all screw connections that have to be loosened for the maintenance and repair work. Any safety mechanisms that have to be dismantled for setting-up, maintenance or repair purposes must be refitted and checked immediately after completing the work.

Maintenance, Care, Adjustment

The activities and intervals specified in the Instruction Manual for carrying out adjustments, maintenance and inspections must be observed, and parts replaced as specified.

All hydraulic and pneumatic lines should be examined for leaks, loose connections, rubbing and damage whenever the machine is serviced. Any defects found must be remedied immediately.

Waste, Disassembly, Disposal

Waste products should be cleared from the machine as soon as possible as not to create a fire hazard.

Ensure that fuels and operating lubricants, as well as replacement parts are disposed of in a safe and ecologically acceptable manner. Note the local regulations on pollution control.

When scrapping (disassembling) the machine and its assemblies, ensure that these materials are disposed of safely. Either commission a specialist company familiar with the local regulations or note the local regulations when disposing of these materials yourself. Materials should be sorted properly.

Repair

Replacement Parts

We cannot accept any liability whatsoever for damage due to the use of parts made by other manufacturers or due to unqualified repair or modification of the machine.

Repair, Electrical

The power supply must be switched off (master switch off) and secured so that it cannot be switched on again inadvertently before starting any work on live parts.

Those parts of the machine and plant on which inspection, maintenance or repair work is to be carried out must be isolated from the power supply, if specified. The isolated parts must first be checked to determine that they are truly de-energized before being grounded and short-circuited. Adjacent live parts must also be isolated.

The protective measures implemented (e.g. grounding resistance) must be tested before restarting the machine after all assembly or repair work on electric parts.

Signal generators (limit switches) and other electrical parts on the safety mechanisms must not be removed or bypassed. Only use original fuses or circuit overloads with the specified current rating. The machine must be switched off immediately if a fault develops in the electrical power supply.

The electrical equipment of our machines must be checked at regular intervals and any defects found must be remedied immediately.

If it is necessary to carry out work on live parts, a second person should be on hand to operate the emergency OFF switch or master switch with voltage release in the event of an emergency. The working area should be cordoned off and marked by a warning sign. Only use electrically insulated tools.

Safety

Ventilation/Hazardous Gases

It is the end user's responsibility to ensure adequate ventilation is provided to exhaust any and all noxious or hazardous gases that may be present in the working environment.

Hydraulic and Pneumatic Systems

Work on hydraulic or pneumatic equipment shall only be carried out by persons with training, knowledge, and experience of hydraulic systems. Pressure lines shall be depressurized before starting any repair work.

General Liability

Liability for machine damage and personal injury is extinguished completely if any unauthorized conversions or modifications are undertaken. The machine must not be modified, enlarged or converted in any way capable of affecting safety without the manufacturer's prior approval.

Starting Machine Movements

Read the Instruction Manual carefully to establish which keys and functions start machine movements.

A Word to the End User

The end user has sole responsibility to enforce the use of safety procedures and guards on the machine. Any other safety devices or procedures due to local regulations should be retrofitted in accordance to these regulations and/or the EC Directive on the safety of machines.

Operator's position must always be readily accessible. Escape routes must always be kept clear and safety areas should be identified.

Safety Precautions

Safety should be a constant concern for everyone. Always be careful when working with this equipment. While normal safety precautions were taken in the design and manufacture of this equipment, there are some potential safety hazards.

Everyone involved with the operation and maintenance of this equipment should read and follow the instructions in this manual. Operate the equipment only as stated in this manual. Incorrect use could cause damage to the equipment or personal injury.

It is the owner's responsibility to make certain that the operator reads and understands this manual before operating this equipment. It is also the owner's responsibility to make certain that the operator is a qualified and physically able individual, properly trained in the operation of this equipment.

Specific safety warning decals are located on the equipment near the immediate areas of potential hazards. These decals should not be removed or obliterated. Replace them if they become non-readable.

- ALWAYS keep safety shields and covers in place, except for servicing.
- ALWAYS operate equipment in daylight or with adequate working lights.
- Follow daily and weekly checklists, making sure hoses are tightly secured and bolts are tightened.
- ALWAYS watch and avoid holes or deep depressions.

ALWAYS wear adequate eye protection when servicing the hydraulic system and battery.

- NEVER operate a poorly maintained machine.
- NEVER allow persons to operate this machine without proper instruction.
- NEVER put hands or feet under any part of the machine while it is running.
- NEVER attempt to make any adjustments or repairs to the machine while running. Repairs or maintenance should be performed by trained personnel only.
- NEVER work under the machine unless it is safely supported with stands, blocks or a hoist and blocks.
- NEVER touch hot parts of machine.

1. INSTALLATION

NOTE: It is important that the machine technician read this manual and is familiar with all the functions and safety concerns of the unit before installing and operating.

1.1. Options & Classes



411 CLASSES

Automatic Two-Needle Sleeve & Body Hemmer

PART NUMBER	DESCRIPTION	SEWING HEAD			NEEDLE DISTANCE				MOTOR		
		Pegasus	Yamato	Juki	W & G	Rimoldi	4.5	4.8	5.6	6.4	PANA
4411F05608E	HEMMER/SEAMER, JUKI MF7822 6904S, EFKA DC1500 MOTOR			X							X
4411FY6601E	HEMMER/SEAMER, EFKA YAM 2700, 4.8 YAM 8003H, 2 NDL	X				X					X
4411FY6215E	HEMMER/SEAMER, EFKA YAM VG2700, 5.6, 8003G YAM	X					X				X
4411FY6801E	HEMMER/SEAMER, EFKA YAM VC2700, 6.4, AZ8003 YAM	X						X			X
4411FG6A11E	HEMMER/SEAMER, EFKA, IM CUF, PEG 664, 4.8, WX5204 PEG	X				X			X		X
4411FG7A04E	HEMMER/SEAMER, EFKA PEG 664, 5.6, EX5204 PEG	X						X			X

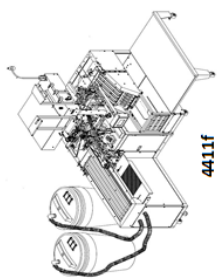

4411f

Features
 Patented Serial Bus Control System
 DC electronic motor
 Combines hemming and closing operation w/auto backlatch
 Sews 100% cotton thread max RPM
 Plain hem or imitation collarete style (patented)
 "No tool" adjustments by operator
 Auto indexing stacker
 Computerized soft touch control system
 Adjustable transfer station for closing straight or contour seams
 Vision system allows operator to inspect each sleeve without stopping sewing
 Unique automatic fold-in-half system allows sleeves be overlapped during sew cycle, increasing production
 Self-contained waste removal system
 Operator and technician friendly for easy adjustments and maintenance

INCLUDED	OPTIONS	Parameters
<p>211-G6606C</p>	<p>311-5A Top Cover 3 Needles 411-X 661-X</p>	<p>MAXIMUM SLEEVE SIZE</p>
<p>5/8 - 1" Wide folder</p>	<p>Hem with Decorative Trim</p>	<p>MINIMUM SLEEVE SIZE</p>
	<p>211-KITOX Thread handling conversion kit</p>	<p>MAXIMUM OVERLAP MINIMUM GAP</p>
	<p>2211-EG1 Active Edge Guide</p>	

E: ECO VERSION
 G : PEGASUS
 Y : YAMATO (VG)
 J : JUKI
 R : RIMOLDI
 2N: 2 NEEDLES
 SBU S: SERIAL BUS
 SLV: SLEEVE
 PANA : PANASONIC
 EFKA : EFKA
 W/SC : WITH STITCH CONDENSING
 N/SC : NO STITCH CONDENSING
 FIH: FOLD IN HALF
 STK: STACKER
 IM CUFF: IMITATION CUFF
 REG C :

Installation

1.2. Technical Data

SPECIFICATIONS	
Voltage (v/ph/hz)	220v 1ph
Current (amps)	15
Air pressure (psi)	90
Air consumption (cfm)	25
Shipping weight (lbs)	1950
Shipping dimensions (w/l/h, inch)	106 x 65 x 67

1.3. Production

Approximately 1950 sleeves hemmed & closed per hour, depending on material, size of parts, and stitch count.

1.4. Footprint

Machine footprint is 57"x93". Leave enough free space around to be able to open all doors and have access for maintenance.

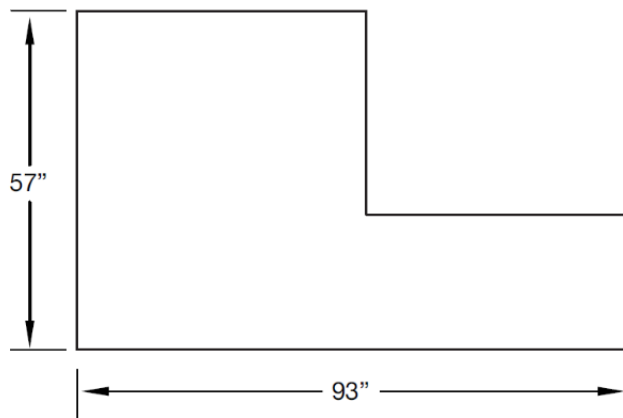

1.5. Machine Identification Label

Machine identification is located on top to the table.

Its contents are the machine class and the Serial Number. Ex: 208005081657

Serial number is divided as follow.

First number identify the order number 208005

Next number month of manufacturing (08)

Next number the year of manufacturing (16)

Following a correlative number 57

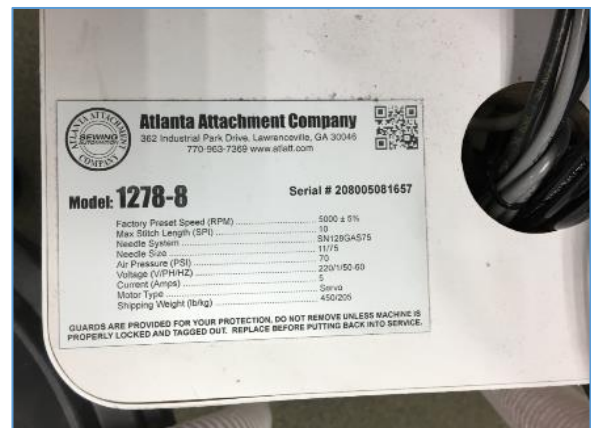

Installation

1.6. Installation & Set Up

1. Remove all shipping straps from machine.
2. Inspect the machine for any damage that may have occurred during shipping. If damage is found, report this immediately to your supervisor. Document the damage and provide details and photographs.
3. The equipment has a locking wheel system for easy movement in the production area.
Pressing the lever in the direction of arrow "ON" locks the wheel and the equipment remains stationary.
Pressing the lever in the direction of arrow "OFF" unlocks the wheel and allows the movement of the equipment.
4. Position the machine in a desired location on a sound and reasonably level floor. Make sure that there is sufficient lighting over the machine. Remove all packing material.
5. Apply with a clean towel a light coat of oil to all black oxide parts to avoid future corrosion.

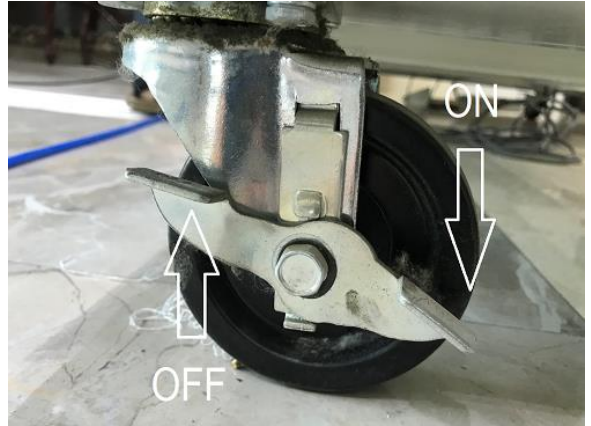

1.7. Parts and Components

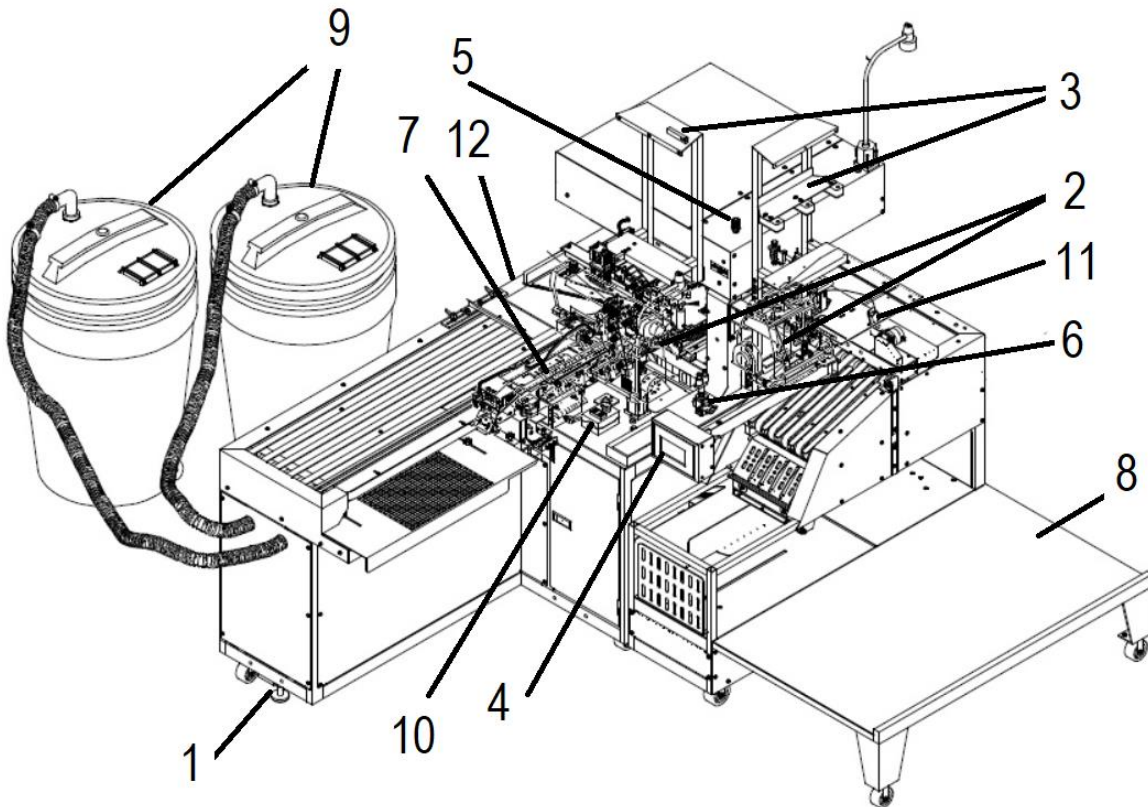

1.- Leveling feet	5.- Power Supply	9.- Waste System
2.- Sewing Heads	6.- Air Supply	10.- Power buttons
3.- Thread Detectors & Stand	7.- Top Conveyor	11.- Electric Eyes
4.- Touch Screen	8.- Bundle Table	12.- Stepping motor Boxes

Installation

1. Leveling

Use the 4 legs to level the machine. Tighten the nuts after finishing.

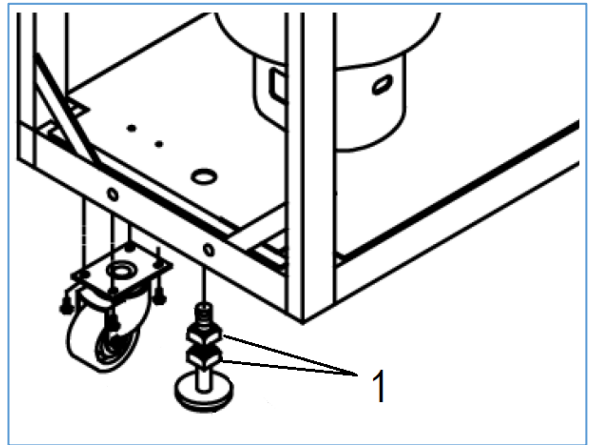

2. Sewing Head

Sewing heads can move during transportation. Make sure they are still on the mount posts and check the following steps.

A. V-belt

After removing machine from crate, check that both V-belt tensions on the hemmer and the seamer are properly adjusted

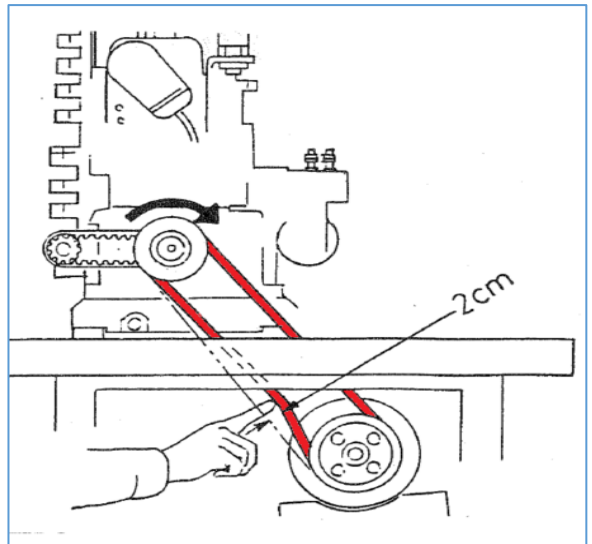

B. Lubrication

Before shipping, all the oil in the sewing head should have been drained. Be sure to supply oil to the sewing head before using the machine. Follow the lubrication procedures of the sewing head. (ISO Viscosity Grade 22 part #SO). Make sure that the oil level is at maximum. Turn the handwheel of the head and check the freedom of movement. Use the manual of the sewing head as a reference.

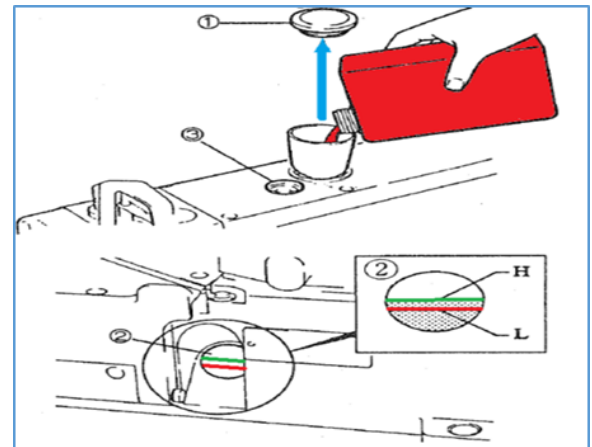

Installation

3. Thread Detectors

- Assemble all thread stands and thread detectors according to the pictures

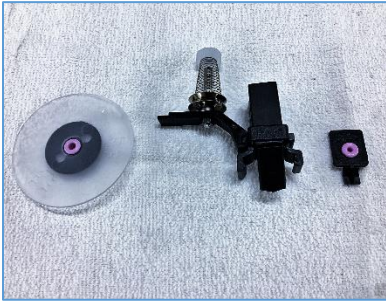

- Connect thread detector to the unit following steps A to F



A

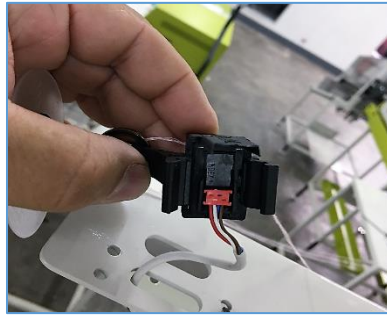

B

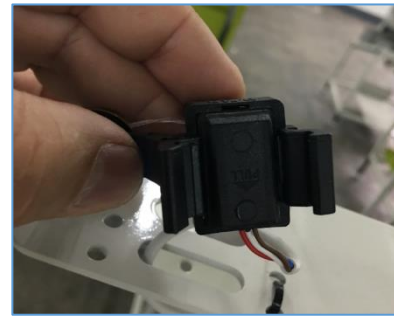

C

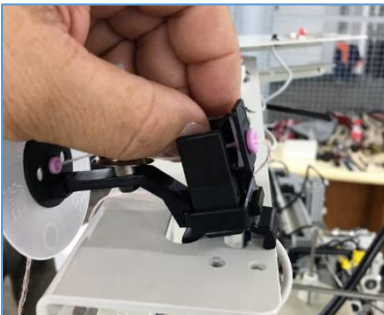

D



E

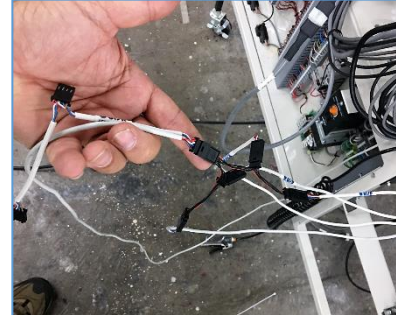

F

- Pass thread through detector picture A and the slot on the tension post as shown on B.



A

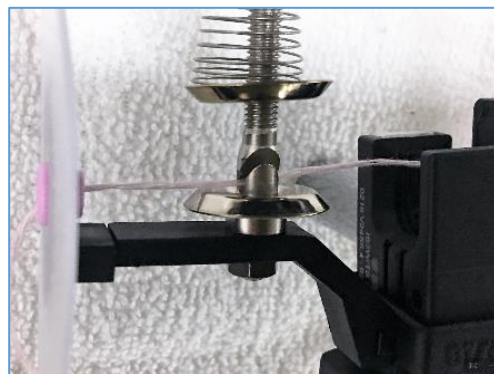

B

Installation

4. Touch Screen

Install Touch Screen. (Serial Bus)

Connect Serial Bus cables to the back of the screen on the connector "1" as show in the picture.



5. Power Supply

The machine should only be connected to the power grid of the plant by a qualified electrician who is aware of local regulations. Before turning on the main switch, verify that all connections are secure. An isolation transformer can be convenient depending on the state of the power supply. Power requirements: 208-230 Vac, single phase. 15 Amp. Connect wires 1 and 2 to a 220V source and the Green / Yellow "G" wire to ground.

NOTE: It is important that the green / yellow wire is connected to ground and this at the same time to all the components of the machine. Follow the connections according to the following graphic.

Turn "ON" the Lock Out Tag Out "4" Main Switch inside the control box. The green Light should light

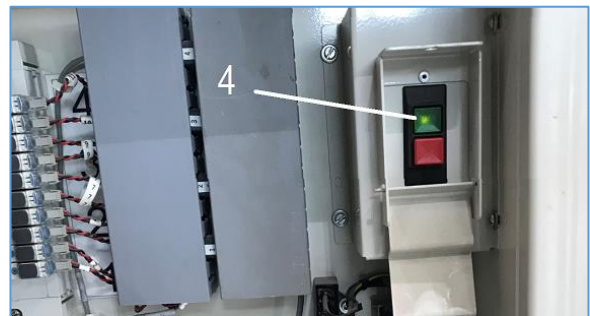
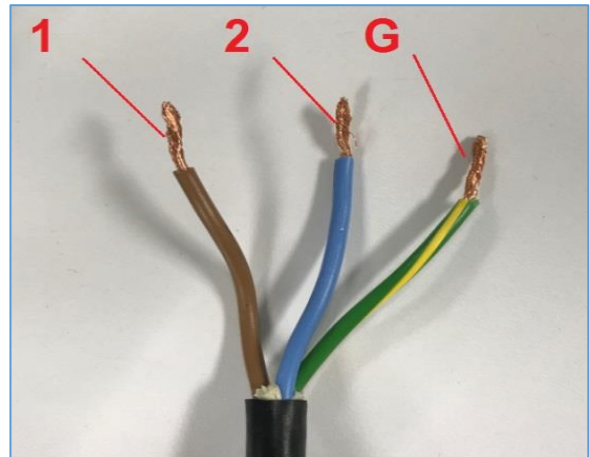

6. Air Supply

WARNING: Some moving parts can be activated when opening the valve. Only compressed, dry and filtered air should be used. Make sure that the air pressure always stays within the specified ranges, otherwise, faults can occur.

Feed two 3/8-inch diameter air lines to the air inlet connectors with a pressure greater than 90 psi (8 Bar) and a minimum flow of 25 SCFM per minute. The 90-pound pressure must be maintained throughout the automatic cycle.

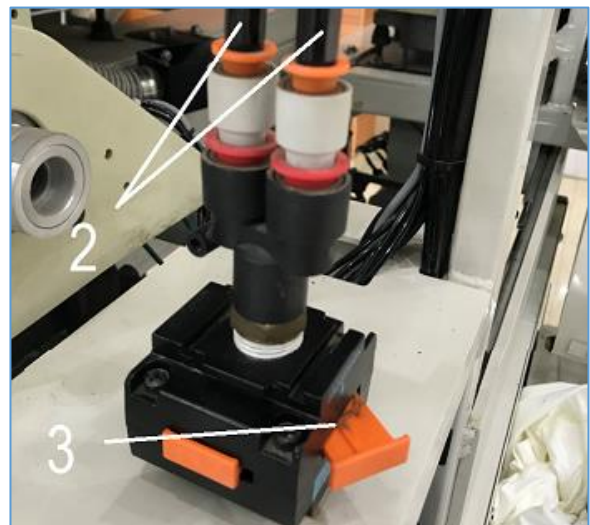

Installation

7. Folder

Folder may be removed for transportation. Install the folder attaching the 2-bottom knob that hold it to the bracket.

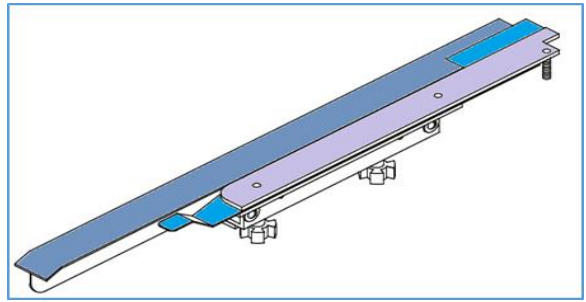

8. Top Conveyor.

Install the top conveyor on the rail guide assembly. Connect the airlines and the eye cable.



9. Bundle Table

Install bundle table according to the drawing.

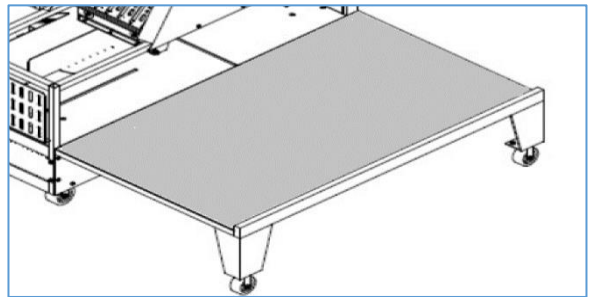

10. Waste System

Connect both waste tubes to the ends of the venturis. Make sure the filter elements are in place on the waste units.



1.8. Power “ON”

WARNING: The unit will be energized, and some moving parts can be activated when turning on the machine.

1. Power Button

Twist the Emergency Stop Red button clockwise to return to its normal position. Turn the machine “ON” by pressing the green button on the box. Machine will first display the language choices and after several seconds, it will show the “READY” screen. This screen is the one that the operator will always see upon power up



Installation

2. Electric Eyes

With the power **“ON”** examine all electric eyes (yellow) and ensure they are all adjusted and functioning properly. See service section for instructions. The unit has multiple electric eyes.



3. Stepping Motors

The pilot light on the box should be amber when the equipment is on. Press the **“JOG”** buttons and check the function of all stepping motors.

The upper one controls the two speeds of the chain puller. The button one controls the speed of the hemmer conveyor and the seamer conveyor.



4. Pedals

The unit uses 2 sets of pedals. They are tied to the machine frame. Remove the ties and locate them to the right positions.

A. Hemmer Pedal

Left. The hemmer pedal runs the Hemmer sewing head in manual, and in automatic, starts the unit. Rotate the hand wheel of the Hemmer by hand and check for freedom of movement. Hand wheel rotation should already be set. Step on the sew pedal and verify proper function of the sewing head.



B. Stacker Pedal

Right. Cycles the stacker unloader.

C. Seamer Pedals

They are located under the seamer head. They operate the seamer head. One is to raise the presser foot and the other one runs the sewing head.

Rotate hand wheel of the seamer by hand and check for freedom of movement. Step on the sew pedal to check hand wheel rotation. Viewing the machine from the hand wheel end, the hand wheel must be turning clockwise.

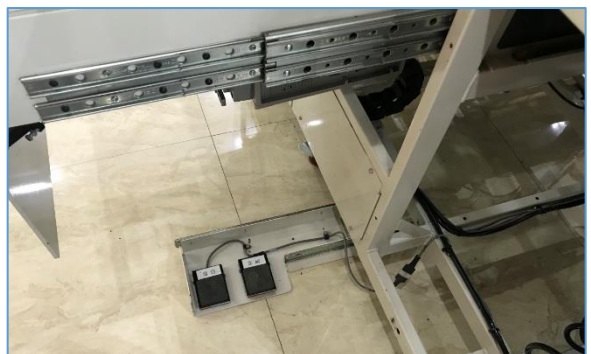

1.9. Interim Storage

If the machine has to be stored temporarily, it must be oiled or greased and stored in a dry place where it is protected from the weather in order to avoid damage. A corrosion-inhibiting coating should be applied if the machine has to be stored for a longer period of time and additional precautions taken to avoid corrosion

2. OPERATOR INSTRUCTIONS

NOTE: It is important that the machine operator read this manual and is familiar with all the functions and safety concerns of the unit before operating.

CAUTION: There are cloth and thread trimming knives on this piece of equipment. These knives cut automatically. DO NOT put fingers or hands in or around these knives. All adjustments made to the sewing machine head or knives should be done with the power off.

2.1. General Description

The 411F is an electronically controlled automatic workstation consisting of a conveyORIZED hemming system, fold-in-half station, a closing station with automatic backlatch and a programmable indexing stacker.



- Patented Serial Bus Control System
- DC electronic motor
- Combines hemming and closing operations with auto backlatch
- Sews 100% cotton thread max RPM
- Plain hem or imitation collaret style (patented)
- “No tool” adjustments by operator
- Auto indexing stacker
- Computerized soft touch control system
- Adjustable transfer station for closing straight or contour seams
- Unique automatic fold-in-half system allows sleeves to be overlapped during sew cycle, increasing production
- Self-contained waste removal system
- Operator and technician friendly for easy adjustments and maintenance



2.2. Individual Components

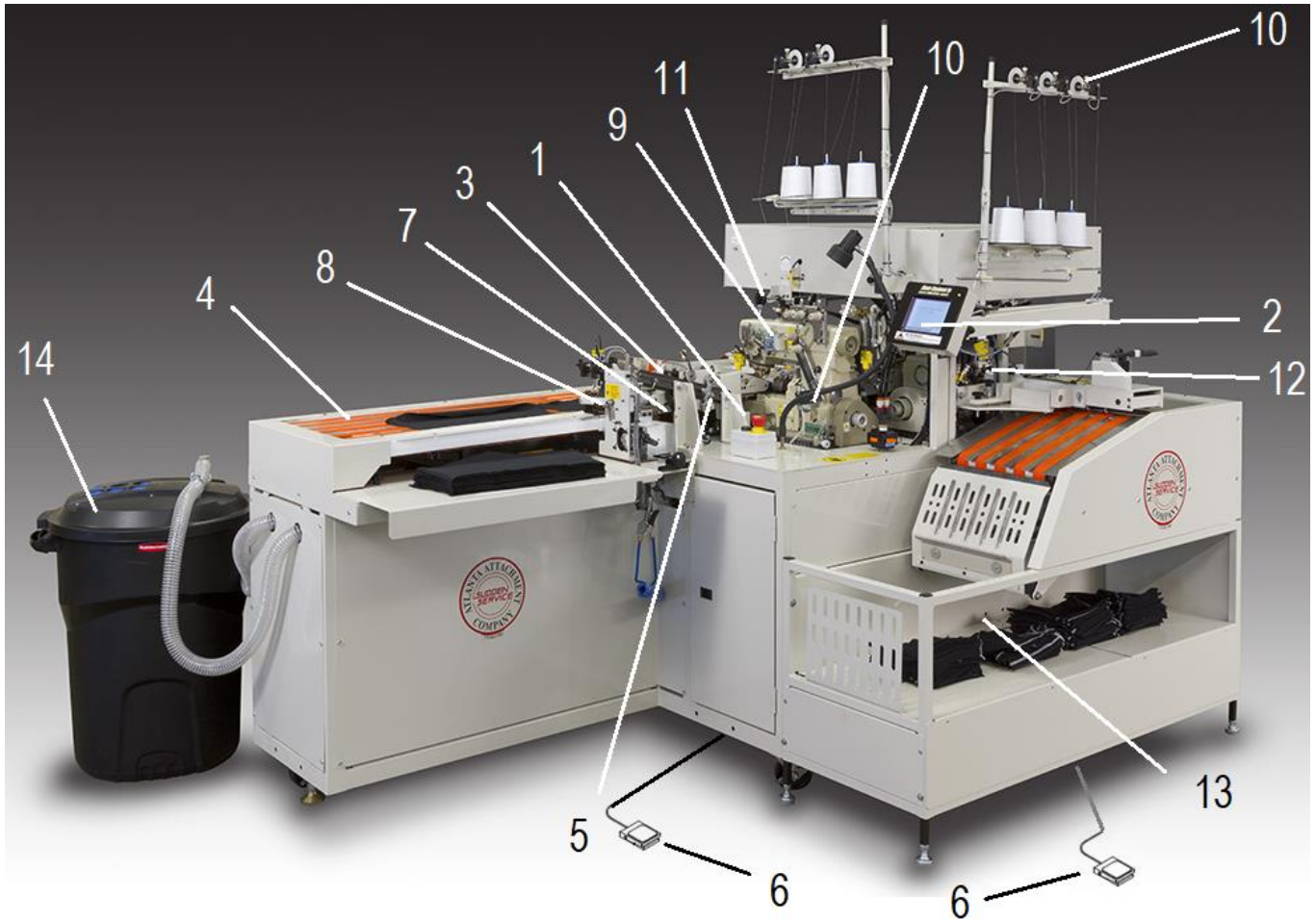

1.- Power Switch	9.- Hemmer Sewing Head
2.- Touch Screen	10.- Thread detectors
3.- Hemmer Upper Conveyor	11.- Fold in Half Station
4.- Hemmer Lower Conveyor	12.- Seamer Sewing Head
5.- Folder	13.- Sleeve Stacker
6.- Pedals	14.- Waste System
7.- Edge Trim	
8.- Edge Guide (optional)	

Operation Instructions

1. Power Switch

CAUTION: Unlocking the button with the Power “ON” engaged will turn on power to the machine. The Power Switch allows the operator to start and stop the automatic function of the machine, shut off power to the machine in the event of an emergency.

A. Power On

The green button turns the machine power on.

B. Emergency Stop

The red knob turns the machine power off. This button will lock when pressed. Twisting the button will cause it to unlock and return to its normal position.



2. Touch Screen

The touch screen controls all machine functions. More details are available in related chapters in this manual.



3. Hemmer Upper Conveyor

The upper conveyor feeds the sleeve into the hemmer. It can be easily raised up after loosening the holding bolt.

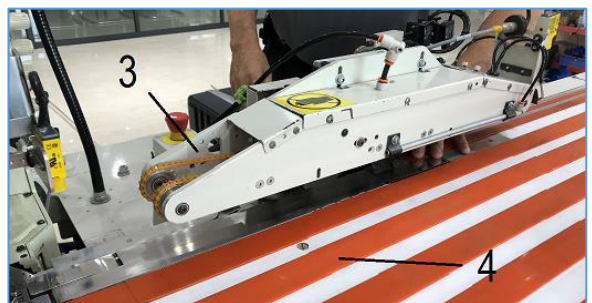

4. Hemmer Lower Conveyor

Together with the top conveyor, it is responsible for feeding the sleeve into the hemmer.

5. Hemmer Folder

The folder turns the edge of the sleeve under to form the hem before sewing. To remove it from the unit, loosen the 2 knobs.

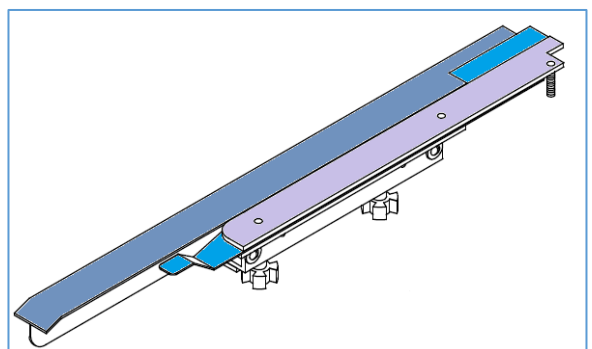

6. Pedals

The machine has 4 Pedals. 2 in the hemmer area and 2 under the Closer area.

A. Hemmer Sewing Head

On the Ready page, activating this pedal starts the hemmer belt, and the machine is ready to be loaded. In the manual mode, it runs the hemmer head.

B. Push Tray Pedal

Pressing the Unload pedal activates the Stacker cylinder, unloading the sleeves stacks to the bundle table.

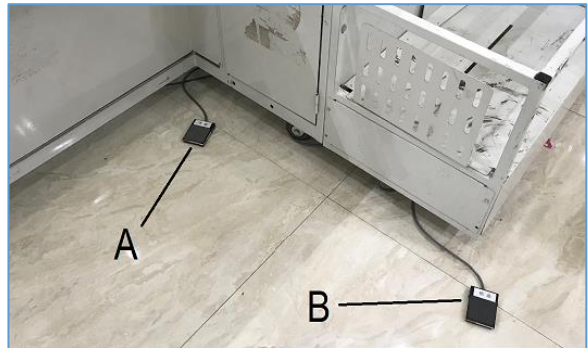

C. Seamer Sew

Activating this pedal runs the seamer manually.

D. Seamer Presser foot.

Activating this pedal will raise or lower the seamer presser foot.

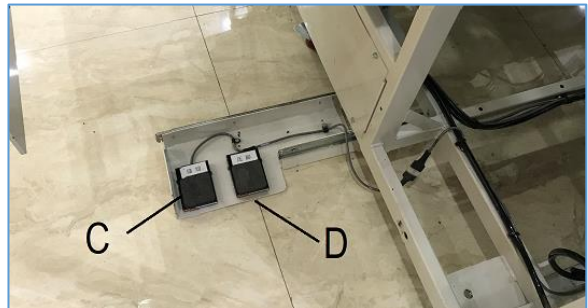

7. Edge Trim

The edge trim knife is used to create a clean straight edge for the hemmed seam. The knife position controls the cut edge position in the hemmed seam in relation to the needles.



8. Edge Guide (Optional)

It guides the edge of the material before it goes into the edge knife.



9. Hemmer Sewing Head

It is responsible for the hem sewing. The machine can be supplied with different sewing heads and different needle configurations.



Operation Instructions

10. Thread Detectors

The unit uses two types of thread sensor.

A. Looper Thread Sensor

For the detection of the Looper thread on the hemmer, a friction type sensor is used.

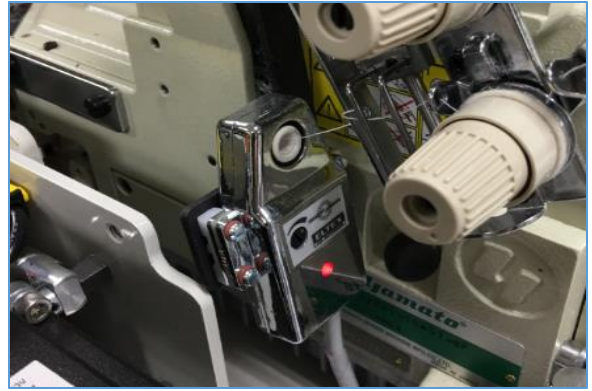

B. Needle Thread Sensor

It is used for thread break detection on the seamer and the hemmer. It is an optical detector.



11. Fold In Half Station

The fold in half section folds the sleeve in half and transports the sleeve from the hemmer to the seamer.

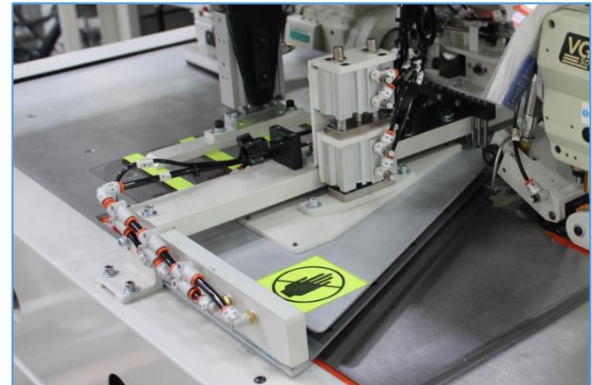

12. Seamer Sewing Head

It sews the closing seam on the sleeve.



13. Sleeve Stacker

The stacker moves the sleeve from the seamer conveyor to the stacker tray. When the bundle stack is done, the stack is moved, and a new stack is begun. The unload pedal moves the stacks to the bundle table. When stacker full light is illuminated, operator depresses the unload pedal to move bundles.



Operation Instructions

14. Waste System

It only runs while the machine is in operation to reduce air consumption. It has filtered waste containers to trap lint. It needs to be cleaned every day. See maintenance section on this manual



2.3. Touch-Screen

1. General Operation

Twist the Emergency Stop Red button to return to its normal position. Turn the machine "ON" by pressing the green button on the box.



The machine will first display the language choices and after several seconds it shows the "READY" screen. This screen is the one that the operator will always see upon power up.

CAUTION: Do Not Use Any Sharp Objects to Touch the Screen

The graphics images presented on the touch screen show "3-dimensional" buttons, which may be pressed to access other screens, change counters and timers, or actuate hardware. Areas lacking the "3-dimensional" border contain information only. The row of buttons across the bottom of the screen are called Standard buttons. They will appear or change based on the needs of the current screen.



RESET: Always brings the machine back to its original power up state.



LANGUAGE: Return to the language screen. You can select multiple languages to use.



HOME: Leaves the current screen and takes you to the home page.



Operation Instructions

CLOCK: Lower right button allows access to a screen for setting the correct time. While on the Main Screen it allows you to set the time and date. On all other screens it is a display only.



EXIT: Leaves the current screen and takes you to an appropriate screen (usually back one level or to the previous screen you were on.)



CONTINUE: Used to restart an event or function that has been temporarily paused or suspended.

ABORT: Used to correct numbers when typed on the security page.



Other buttons are localized on top of or inside the screen.

ARROWS: Pressing the arrows right or left will take you to the next or previous pages.



COUNTERS: Are identified with the "+" and "-" buttons in the corners. These counters may be adjusted by touching the "+" and "-" boxes.

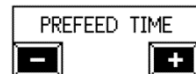

NOTE: When a button has a white background the function is "ON" or enabled. A dark background indicates off or disabled. Some buttons may toggle ON or OFF, others must be held in the ON state.

ERRORS: When the machine detects any sort of error, the machine stops. If not in advanced functions, an error message screen is displayed and often gives the operator several options for recovering from the error.

Other screens display whenever there is a machine error or other condition that prohibits the operation of the machine. Simply follow the instruction on the screens to resolve the problem.

The CONTINUE will restart the machine. The RESET button is pressed to reset all operations.

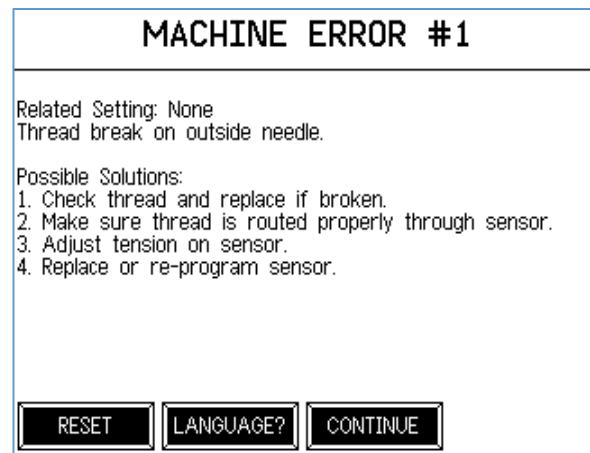

KEYBOARD: There are also advanced settings and advance functions available. These functions are only accessible by a password, and include timers that control machine hardware, input and output test screens, and machine statistics. To get to the advanced functions the appropriate password must be entered at the security screen. Security access is reset whenever the main power is turned off, or the RESET button on the main page is pressed.

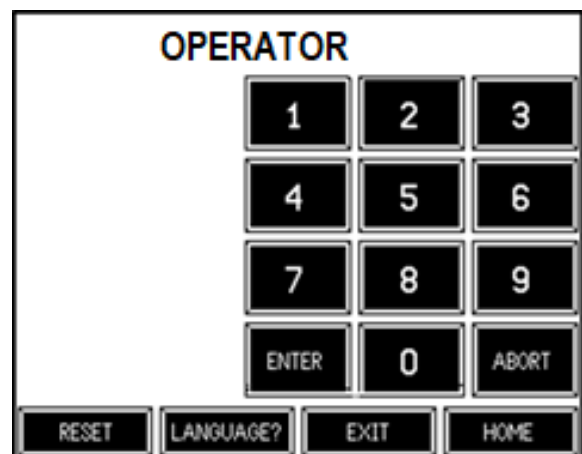

Operation Instructions

2. Available Menus

The operator accessible functions allow normal operation and production information recording. They also report machine problems and let the operator choose how to respond to these errors. In addition, they allow the operator to make important adjustments to the machine. The following is a summary of the different screens and their functions available for the Sewing Operator.

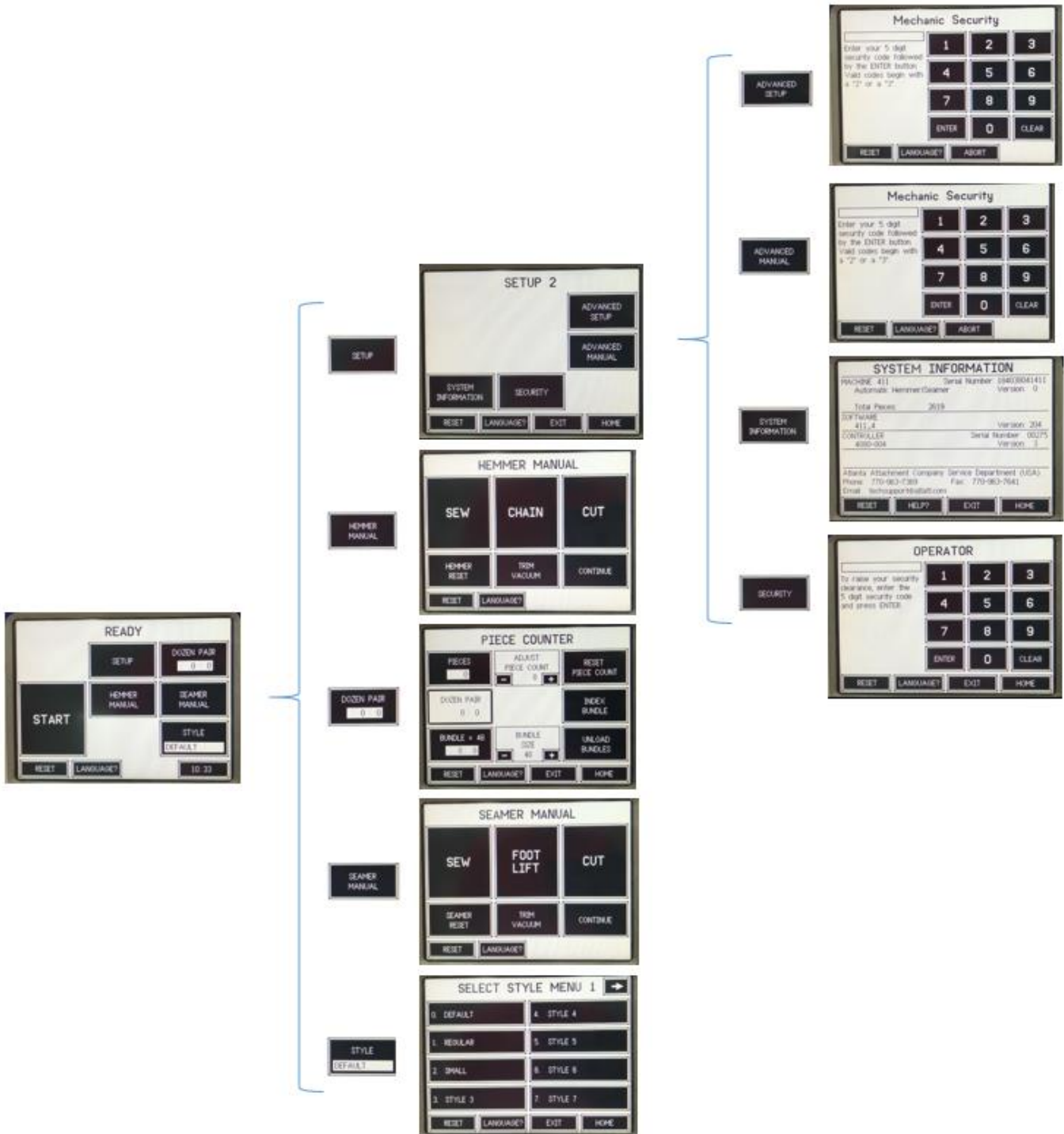

Operation Instructions

READY

After you power it “ON” this screen appears. This is the home operation screen.

START

This button starts the machine in automatic mode allowing the machine to run continually as long as sleeves are being loaded.

SET UP

Allows fast access to the “**SETUP 2**” screen to do several of the machine adjustments. Some of the options are password protected and not available to operators.

ADVANCE SET UP: This button takes you to the Advanced Functions screen. It is locked with a password. It is only to be used by technicians.

ADVANCE MANUAL: This button takes you to the Manual Input and Output Test screens which allow you to test the inputs and outputs on the machine, such as photoelectric eyes and switches. Mechanic security level required. It is locked with a password. It is only to be used by technicians.

SYSTEM INFORMATION: This button takes you to a screen that displays various information about the machine, such as the serial number or software revision number.

SECURITY: Allows you to change your current level of security or change the password for your security level or any level below you. Appropriate security level required.

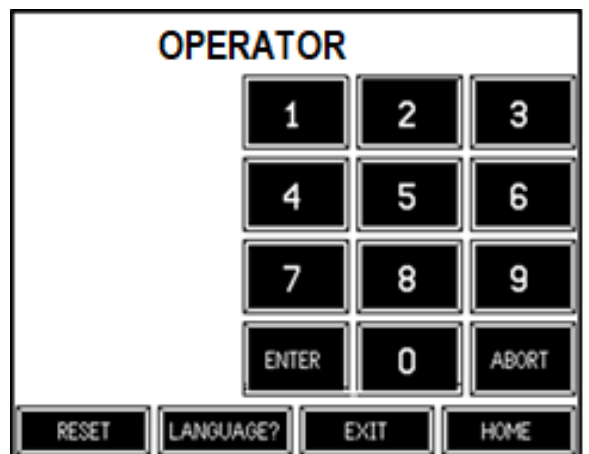
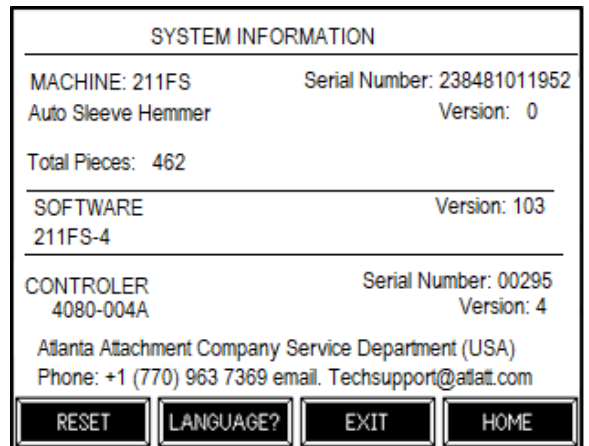
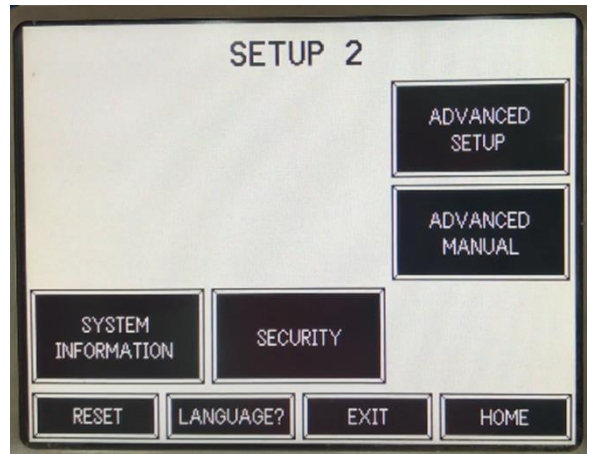

Operation Instructions

HEMMER MANUAL

This button takes you to a screen which allows the operator to manually run the hemmer sewing head in either sewing or chaining mode.

SEW: After pressing the button, the sewing head will run, and puller will run at the sewing speed. The presser foot will be lowered touching the material. There should be material under the presser foot. The sewing head will run as long as the button is held.

CHAIN: After pressing the button, the sewing head will run, and puller will run the chaining speed. The presser foot will be lifted.

CUT: Pressing this button manually activates the thread chop knife.

HEMMER RESET: Resets the hemmer section back to automatic ready condition.

TRIM VACUUM: Will activate the vacuum of the edge trimmer.

CONTINUE: The automatic cycle will resume running.

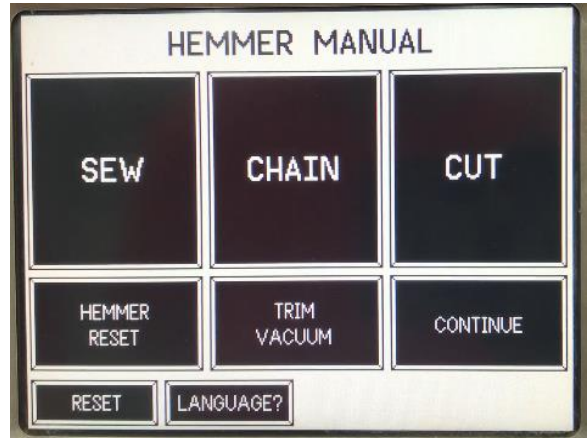

SEAMER MANUAL

This button takes you to a screen which allows the operator to manually run the Seamer sewing head.

SEW: After pressing the button, the sewing head will run. The presser foot will be lowered to feed the material. There should be material under the presser foot.

FOOT LIFT: After pressing, the seamer presser foot will be lifted.

CUT: Pressing this button manually activates the thread chop knife.

SEAMER RESET: Resets the seamer back to the automatic ready condition.

TRIM VACUUM: Will activate the vacuum of the edge trimmer.

CONTINUE: The automatic cycle will resume running.

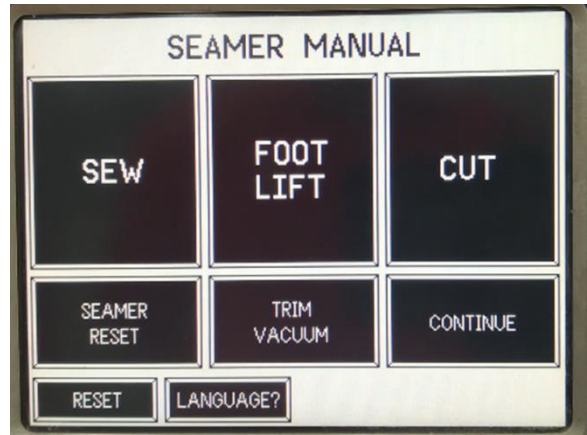

STYLE

From the SETUP screen, the STYLE button will allow an operator to recall any of the 16 styles that are stored. Once recalled, the operator may temporarily modify a style's settings. However an operator is not able to store changes to styles. Of the 16 styles, style "00" holds the factory default settings and cannot be changed even by the technician, style "15" is reserved for AAC technicians.

Once the machine is adjusted for a particular type of sleeve or material the style may be saved and recalled at a later time. Mechanic security level is required to save styles, operators may recall styles.

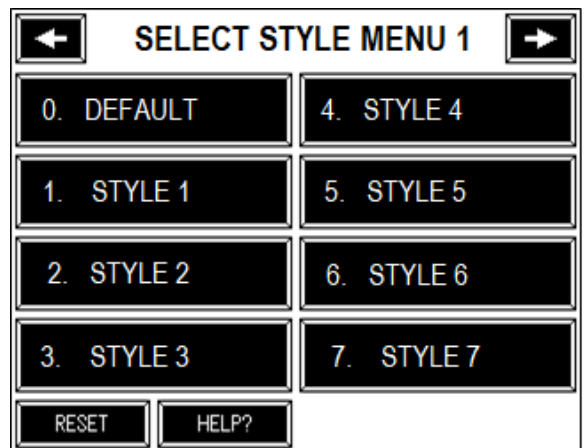

Operation Instructions

PIECE COUNTER

On the MAIN PAGE screen is the piece counter. Pressing this button will allow the operator to select from 3-piece count display formats or to reset the piece counter. The piece counter counts only sleeves which make it all the way to the stacker door. Sleeves sewn through the repair cycle are not counted. On the PIECE COUNTER screen is the BUNDLE button which sets the bundle size and allows a “forced” index of the bundles.

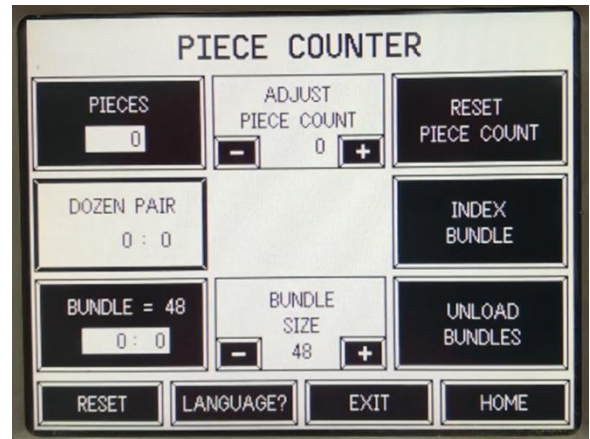

2.4. Sewing Preparation

1. Operation Description

The operator aligns the sleeve to an edge guide, initiates the sewing cycle and continues loading.



The sleeves are automatically trimmed, hemmed, folded in half, transported to closer, backlatched, closed and stacked. Stacker indexing is accomplished by programming the number of sleeves in a bundle.



2. Hemmer Preparation

- Remove the top conveyor and folder.
- Open the machine covers and thread the sewing head according to the sewing head manufacturer.

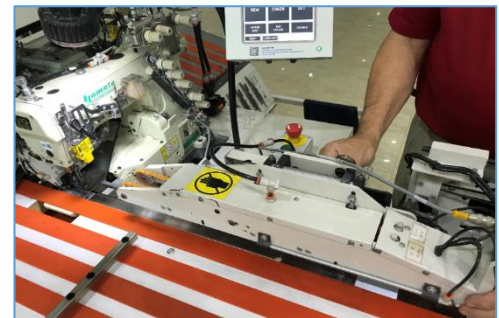

Operation Instructions

A. Looper Thread Sensor

This type of thread detector monitors the consistent movement of thread over a ceramic surface. With the unit running in manual mode, the LED on the detector must not be on. The presence of a red light on any of the detectors indicates thread breakage or maladjustment, thus causing the unit to stop.



B. Needle Thread Sensor

Part Number: (4003-3WT2)

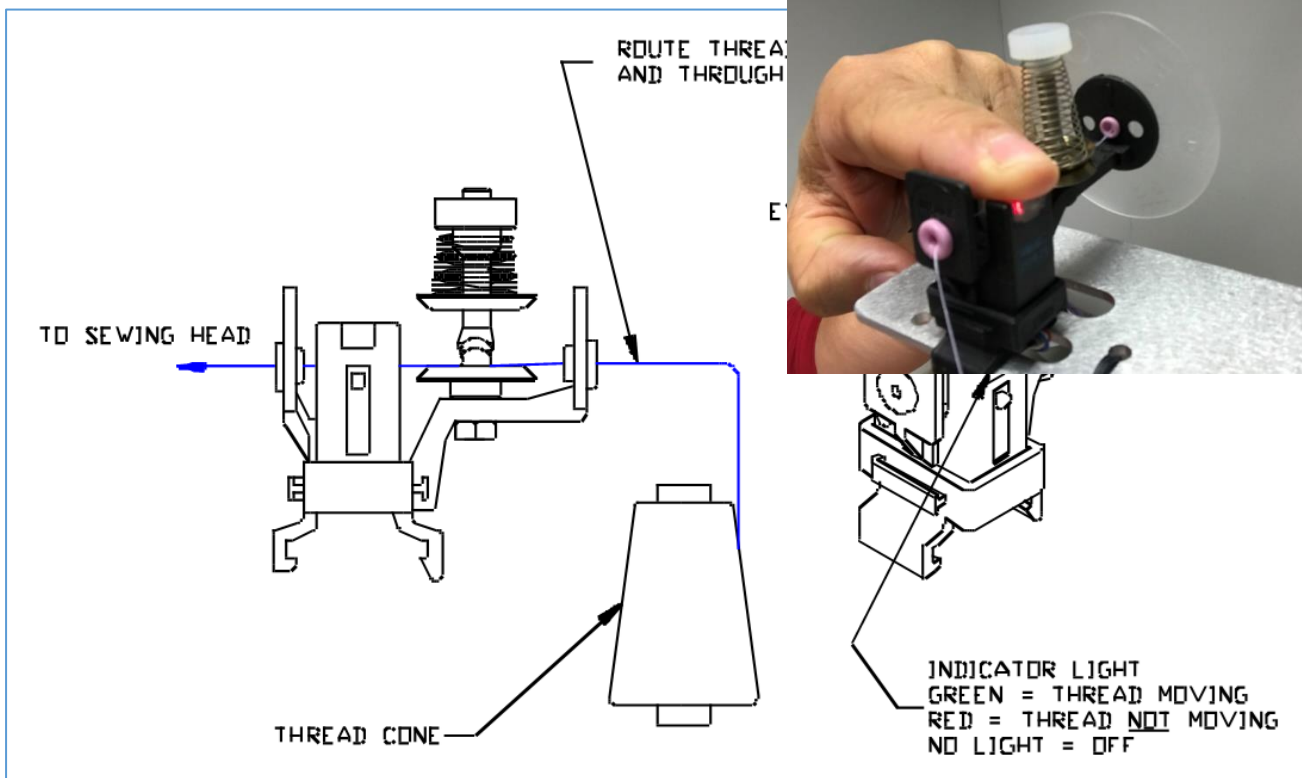

The needle thread sensors are optical sensors that detect the vibration frequency of the thread as it is sewing. The thread must pass the sensor at the correct level and frequency to be detected. The tension spring assembly is the only adjustment for the vibration frequency. If it is too tight, the thread won't vibrate enough. Use the minimum tension needed to get consistent detection.

The sensor can be turned off and reset by pressing the RED on the sensor.

Operation Instructions

- Activate the pneumatic valve “A” to raise the presser foot.
- Manually set a piece of material under the presser foot. Lower the presser foot. You can raise the puller if needed with the valve B.
- Press the Hemmer Manual button on the Ready screen.
- Press SEW and start sewing some stitches on the sleeve to make sure the unit is sewing properly.
- Keep running until the end of the sewing material reaches the presser foot. Release the Sew button.
- After reaching the edge of the material, Press CHAIN on the HEMMER MANUAL screen to sew off of the sleeve.

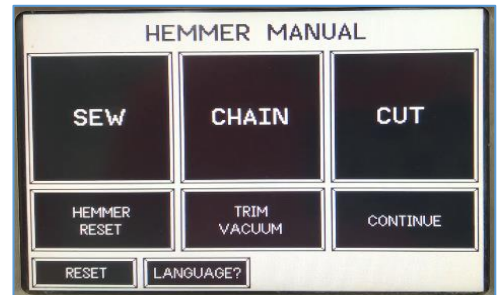
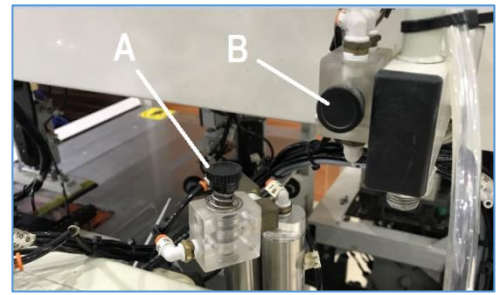

Operation Instructions

- Continue sewing in the CHAIN mode until the sewing material passes the cutting knife.
- Press CUT on the Manual screen. The chain will be cut and pulled inside the tube of the chain vacuum.
- Make sure the folder is in the proper position. Make sure the folder is aligned against the table and the air lines are connected.
- Tighten the folder in position with the 2 knobs underneath.
- Pull the spring pin and lower the upper conveyor into position. Make sure the conveyor is completely flat with the folder. Check that there is not any air line or cable clamped underneath the conveyor. Tighten the top conveyor knob.
- Return the skid plate to its original position.

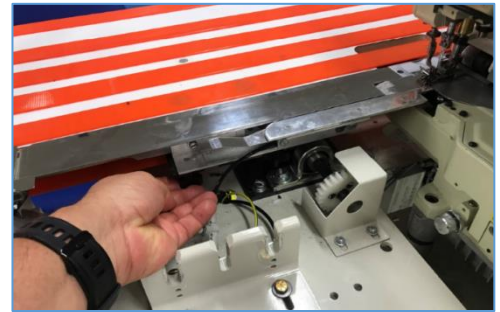

3. Seamer Preparation

- With the machine in the manual mode (Seamer Manual), open both latches on the cabinet and pull out the seamer station.



- Remove the bed plate and open the machine covers.
- Thread the machine according to the sewing head manufacturer. Refer to the chapter of Needle thread Detectors if required
- Close the covers and return the plate to its original position.
- Press the right pedal to raise the presser foot and set a piece of material underneath it.

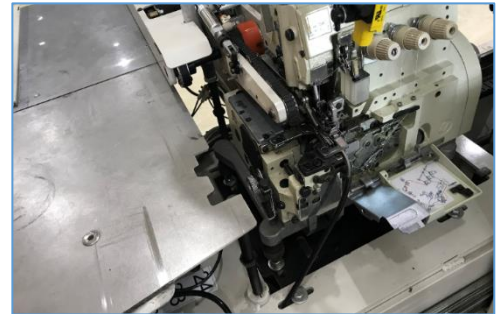

- With the left pedal, run some stitches to make sure the unit is sewing properly.

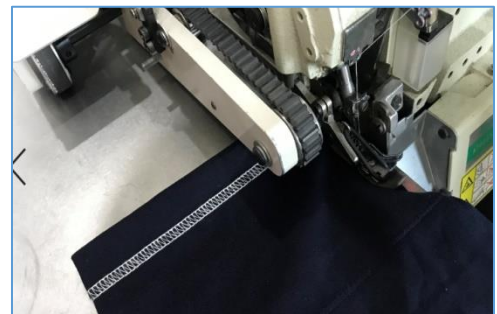

- Keep sewing a length of chain.



Operation Instructions

- Activate the chain cutter by pushing the right button on the cabinet.
- Close seamer cabinet and fasten the latches.



4. Seamer Sew-off (Repair Mode)

1. Machine must be in Automatic mode (READY page) with the seamer extended.



2. Insert the sleeve under the edge trimming cutter and as close to the needle as possible.



3. Depress the sew pedal.
- A. Vacuum comes on.
 - B. Stitching begins.
 - C. Keep the sew pedal pressed until the transfer wheels move the sleeve out of the seamer conveyor.



4. The sleeve will sew through and be stacked.

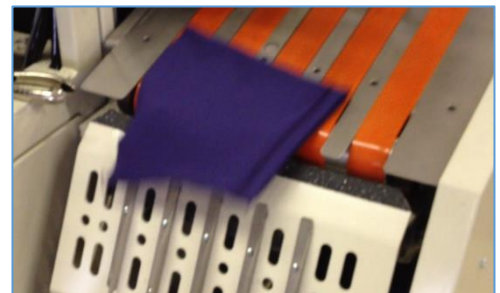

Operation Instructions

2.5. Sewing Sequence

Operator presses START on the READY Screen

- Conveyor belt starts running

- The operator places a sleeve against the edge guide and initiates sewing.

- The operator places a second sleeve against the edge guide.

NOTE: The unit will continue sewing as long as parts are placed on the conveyor within a specific distance. The sew cycle will stop if the operator fails to position the next part, thereby reducing thread waste.

- The hemmer sewing head will hem the sleeve.

- The sleeve will be folded in the Fold in Half station

- The folded sleeve will be transferred by the Transfer 1 clamp from the fold in half station to the Transfer 2 clamp.

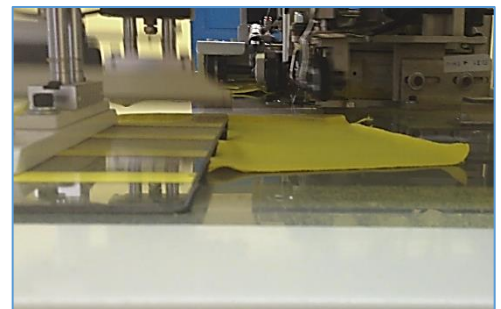
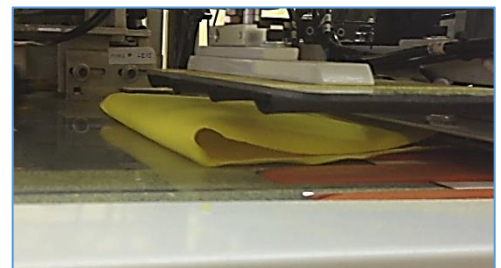
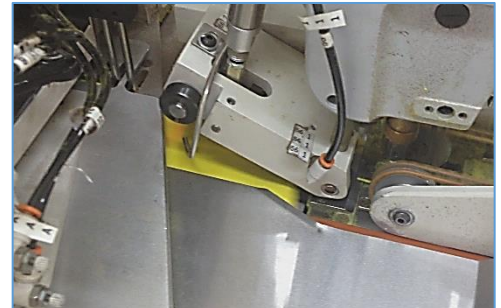
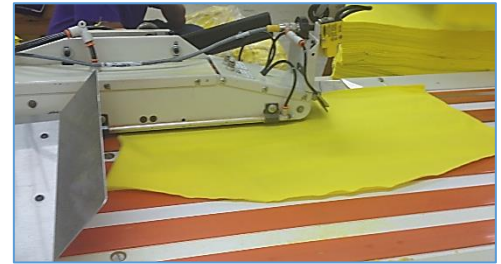
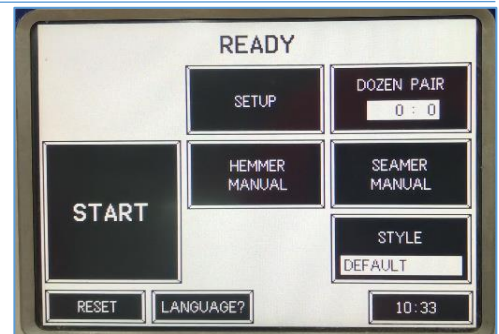

Operation Instructions

The Transfer 2 clamp will transfer the sleeve from the Transfer 1 clamp to the Sleeve Seamer station.

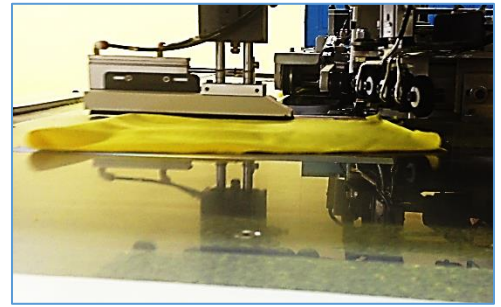

- The Guiding wheels will catch the sleeve and align it in front of the presser foot.

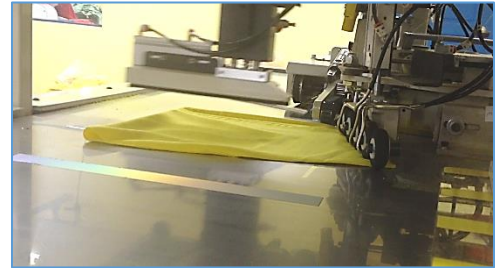

- The Sleeve seamer will close the sleeve.



- The Seamer conveyor transfers the sleeve to the Stacker section.



- The Stacker door catches the sleeve and stacks it in the stacker tray.



- The sleeve is done, and stacking finishes the cycle.



Average production on sleeves is 350 - 400 dozen pair per 8-hour day.

2.6. Maintenance

It is important that the machine operator read this manual and is familiar with all the functions and safety concerns of the unit before operating.

1. General Safety Instructions

Maintenance should only be performed by trained, qualified personnel. Before performing any maintenance or repair work, switch off the electrical, pneumatic, etc. power to the machine at the main source and secure it with a padlock so that it cannot be switched on again without authorization. Refer to lockout/tag out procedures

- Always wear proper safety equipment when operating or performing maintenance on any equipment.
- All recommended maintenance is for a single shift schedule; adjust as necessary for a multi-shift operation.
- Equipment should not be used for purposes other than designed or specified.
- The machine shall be switched off, come to a standstill, and be secured so that it cannot be switched on again inadvertently before starting any maintenance work whatsoever.
- Use proper lockout/tag out procedures to secure the machine against inadvertent startup.
- Remove any oil, grease, dirt and waste from the machine, particularly from the connections and screws, when starting the maintenance and/or repair work.
- Do not use any corrosive-cleaning agents.
- Use lint-free rags.
- Retighten all screw connections that have to be loosened for the maintenance and repair work.
- Any safety mechanisms that have to be dismantled for setting-up, maintenance or repair purposes must be refitted and checked immediately after completing the work

2. Preparation

Remove folder and top conveyor, open all sewing head covers.









A. Oil and filter change intervals should occur 30 days (or 200 Hrs. of operation) after installation and every six months (or 1200 Hrs. of operation) thereafter. If you run the unit on 24-hour shifts, factor in the hours run and change accordingly.

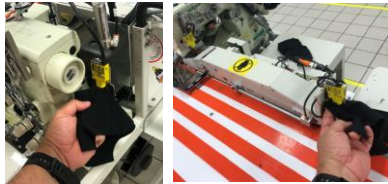

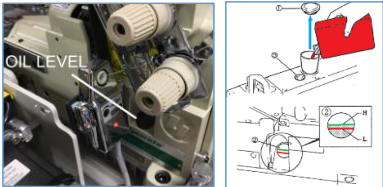
Preventive Maintenance 8 Hrs

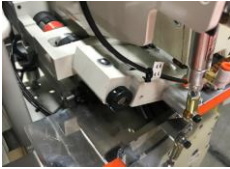
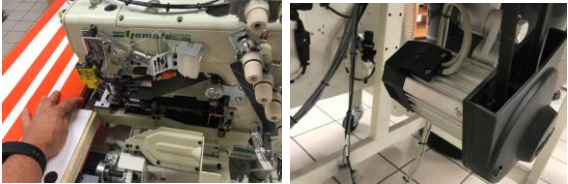
Model: 411F	Required Materials
Serial #:	
Operation: Sleeve Hemming	
Sew Head:	
Serial #:	
Needle: SNUY128GAS-70	

Before starting the day's shift with "The Machine Off"	
Wipe with a clean cloth of all electric eyes and reflecting tapes	
Check for liquid waste in the air filter and drain if necessary.	
Check the oil level in the lubrication tank and add if required. Keep Level between lines H and L of oil gauge	
Clean filter on waist container. Dump as necessary	
After a day's shift with "The Machine Off"	
Check for thread accumulation on rollers, pulleys and the moving parts	
Open covers, blow out and wipe with a clean cloth the machine and remove any dirt or tangled threads. Clean sewing motor ventilation	
Cover the machine and notify the supervisor of any unusual noise or abnormality that is present during the working shift	

3. SERVICE INSTRUCTIONS

NOTE: Maintenance should only be performed by trained, qualified personnel.

3.1. Lock Out/Tag Out Program

"Lock out/Tag out (LOTO)" refers to specific practices and procedures to safeguard employees from the unexpected energization or startup of machinery and equipment, or the release of hazardous energy during service or maintenance activities. This requires that a designated individual turns off and disconnects the machinery or equipment from its energy source(s) before performing service or maintenance and that the authorized employee(s) either lock or tag the energy-isolating device(s) to prevent the release of hazardous energy and take steps to verify that the energy has been isolated effectively. The following references provide information about the LOTO process.

Equipment Energy Control Procedure Lockout/Tagout Program				
Description: Sleeve Hemmer		Model: 411F		
Manufacturer: Atlanta Attachment Co.		Location:		
Energy		Location	Magnitude	Control Method
Electrical:	X	Disconnect/Ctrl Box	220V	Lockout & Tag
Pneumatic:	X	Main Regulator	90 PSI	Lockout & Tag
Gravity:	X	Conveyors, Belts		
Remember to Release All Stored Energy!				
Shutdown Procedure:				
Inform all affected personnel that the machine will be in Lockout status. Turn the power and pneumatic disconnects to the OFF position. Fill out the tag with necessary information of the Lockout. Install the Lockout device. Verify all stored electrical energy has been released by pressing the power on button. Also, use meter to test circuits in the electrical panel to insure stored energy is released there as well. Perform necessary maintenance, services and/or repairs.				
Startup Procedure:				
Inform all affected personnel that the Lockout of this machine is being removed. Replace any guards or safety devices which may have been removed during maintenance. Remove the Lockout device and tag. Turn the power and pneumatic disconnects to the ON position. Push the green button on the back of the control panel to turn the machine on. Inform all affected personnel that the Lockout has been removed and that the machine is ready for normal production operation.				

Approved By: _____

Date: _____

3.2. Mechanical

NOTE: All maintenance should be performed by a qualified service technician.

1. Hemmer Adjustments

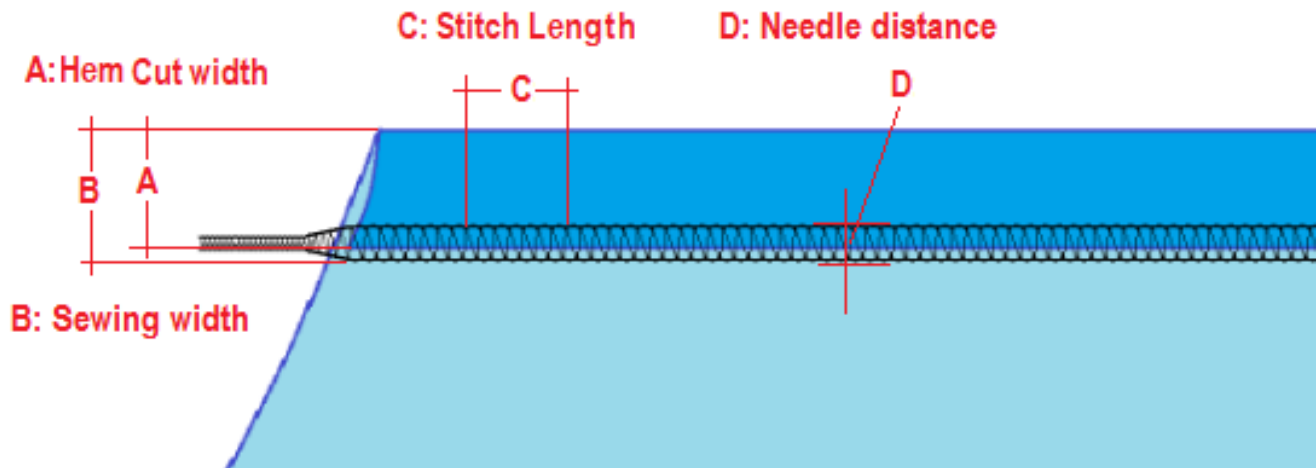

A. Hem Cutting Width

The cutting margin is determined by the knife position in relation to the needles. To adjust, loosen the screw below the knife assembly and turn the knob to move the complete cutting assembly in or out.



If the screw is turned counterclockwise, the knife will move to the inside and the raw edge of the material will be inside the cover stitch.

If the screw is turned clockwise, the knife will move to the outside and the raw edge will be outside the cover stitch.

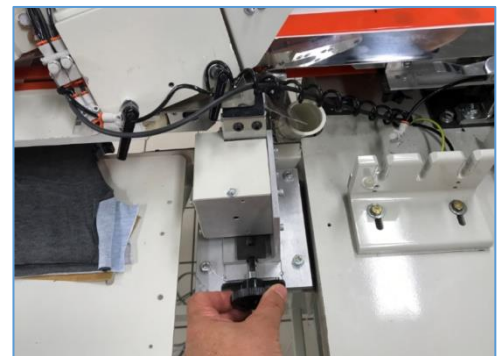

Service Instructions

1. Material Edge Trimming Guide Adjustments

The Material Guide Roller Should Be Adjusted In three Dimensions

A. Vertically

It should be located vertically to be 2 times the thickness (1) (Fig. 1) of the sewn material above the lower fixed knife.

This is accomplished by loosening the two 1/4-20 bolts (2) (Fig. 4) attaching the material guide roller support block to the frame of the upper conveyor.

Care should be taken to keep the support block moved to the right as it is also used to tension the drive belt. Once the adjustment is made, tighten the two 1/4-20 bolts securely.

The material guide spring (3, Fig. 1) should be adjusted to be only slightly above the lower fixed knife.

The material roller should NOT contact the material. It is used to guide the material into the knife. If the wheel pinches the material, the cut edge will be ragged.

B. Along the sewing plane

The material guide roller should be adjusted along the sewing plane so as to be centered at the right 1/3 (Fig. 2) of the cutting edge of the upper movable knife blade.

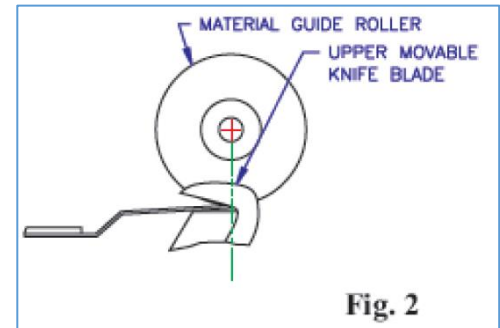
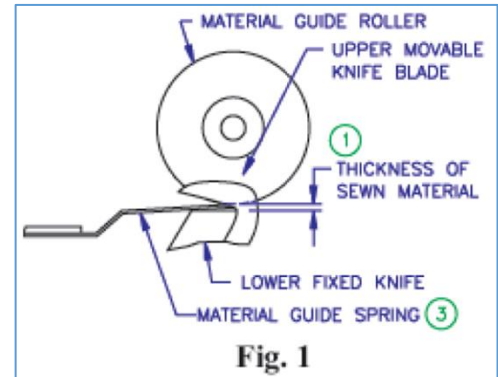

This is accomplished by loosening the two 1/4-20 bolts (4) (Fig. 4) located in the slotted holes of the upper conveyor mounting bracket. After locating the material guide roller properly, tighten the two 1/4-20 bolts securely.

C. Along the drive shaft

The material guide roller should be adjusted along the drive shaft to leave 1/16" clearance between the roller and the upper movable knife blade. This is accomplished by loosening the set screws (5) (Fig. 3) in the material guide roller and moving the roller along the shaft until the desired 1/16" clearance is reached. Tighten the set screws. Do not overtighten, the roller is plastic

NOTE: This adjustment will have to be repeated every time the material trimming knife is adjusted for the amount of trim off.

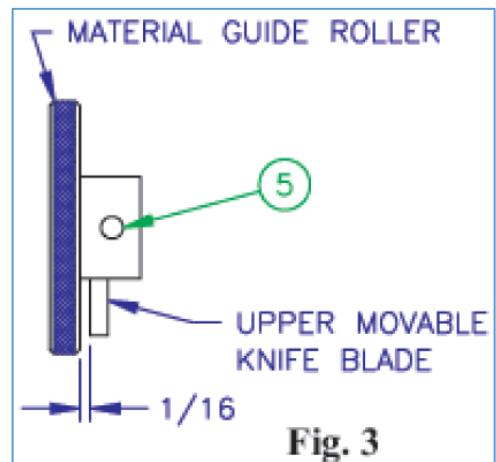
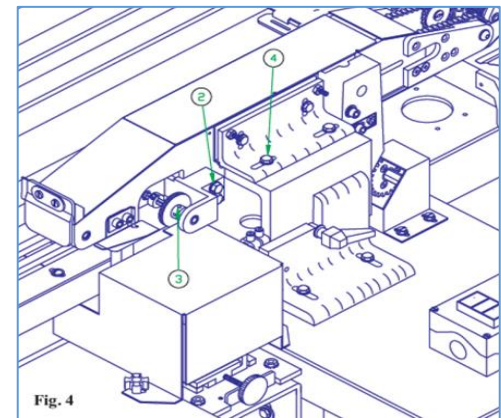

Service Instructions

B. Sewing Width

The sewing width is the distance from the left needle to the folded edge of the material. We will need first to make the Folder adjustments, the top conveyor adjustments and the sewing head adjustments.

1. Folder Adjustments

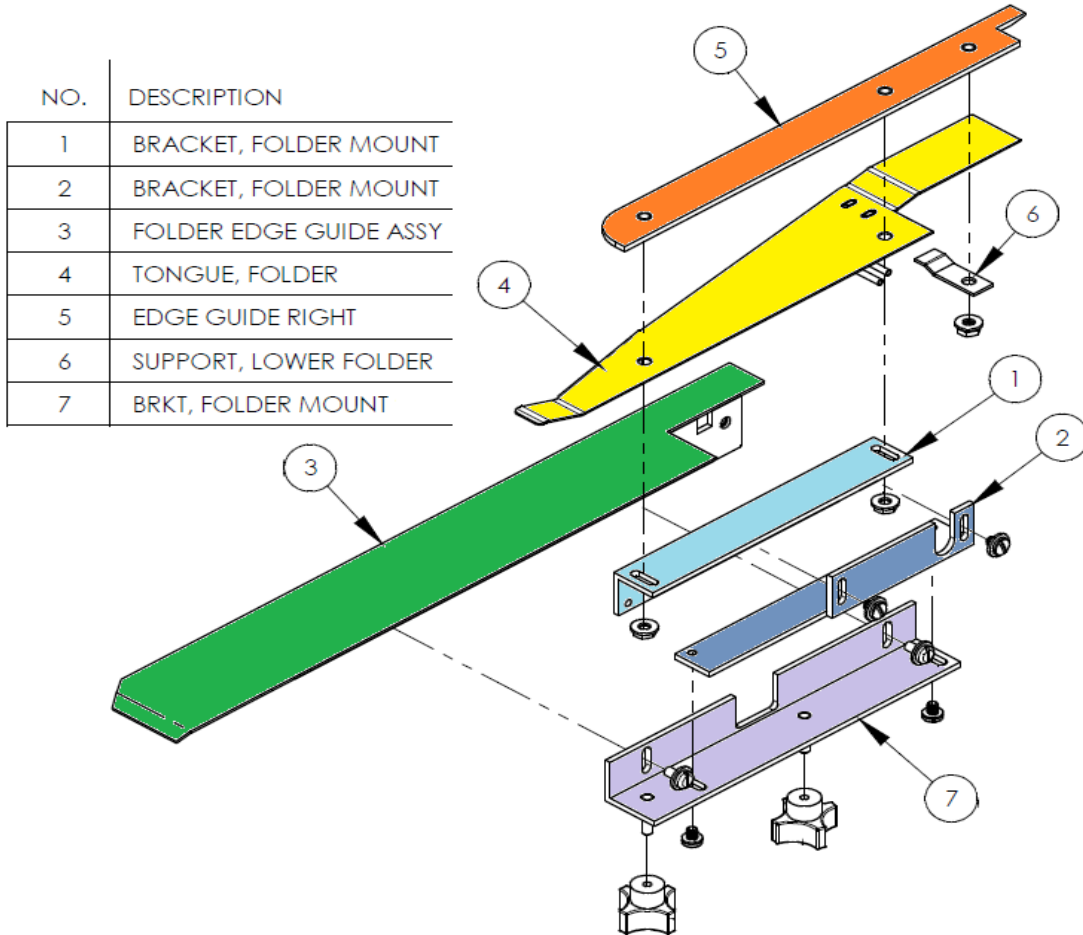

A. Polish

Folder assembly must be perfectly smooth and shiny on all surfaces that will have direct contact with the sewing material and the top belt.

B. Holding plate

Assemble the Folding Edge Guide with the folder mount bracket and make sure that the 2 screws that hold it in the bracket are touching the end of the slots. If necessary, loosen the 2 screws that hold the bracket to the wooden table, install the folder and tighten it up.

C. Alignment

With the folder assembly bracket tight into the Holding plate, tight the 2 screw making sure the Folding Edge Guide is in contact and aligned with the wooden table. Make sure the folder is parallel to the table

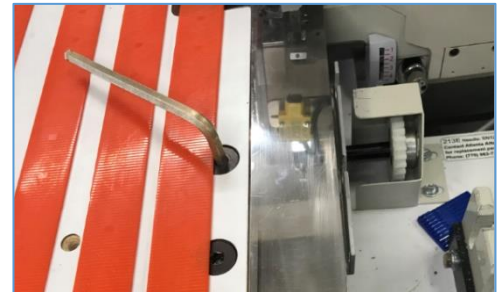

Service Instructions

D. Height of the Folding Edge Guide

Folding Edge Guide must be aligned in height with the wooden table and the sewing head. Loosen the 2 screws that hold the Folding Edge guide to the folder mount bracket and adjust the height.

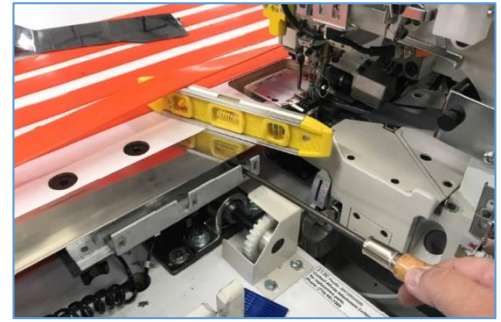

E. Sewing Head Height

The height of the sewing head must match the height of the Folding Edge Guide and the table. Loosen the 2 nuts that hold the sewing head support post and adjust if required. Tighten the nuts.

Set 1/16" gap between the rear of the folder and the sewing head.

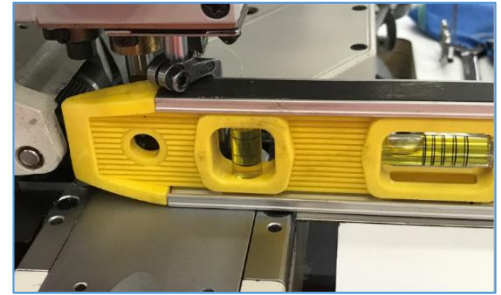

F. Folder Material Gap

Set the capacity of the folder by adjusting the gap between the folder edge guide and the right edge guide.

The space from the Edge Guide Right to Folder Edge Guide should be approximately 2 millimeters, and it should be parallel from the beginning to the end.

For thin material, a 1.5 mm gap can be used. For thick material, 3mm or more may be required.



G. Height of the Edge Guide Right

The right Edge guide must be aligned in height with the Folder Edge guide. Loosen both screws and adjust as required.

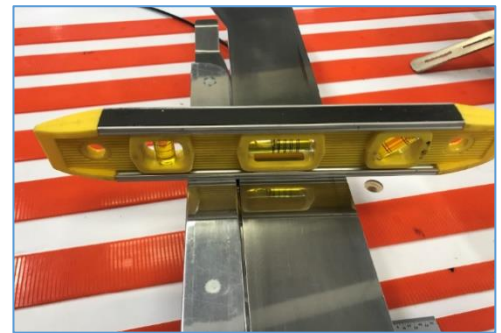

After completing adjustments, verify carefully that X and Y are completely flat, and the distance between the Edge Guide Right and the Folder Edge guide is parallel.

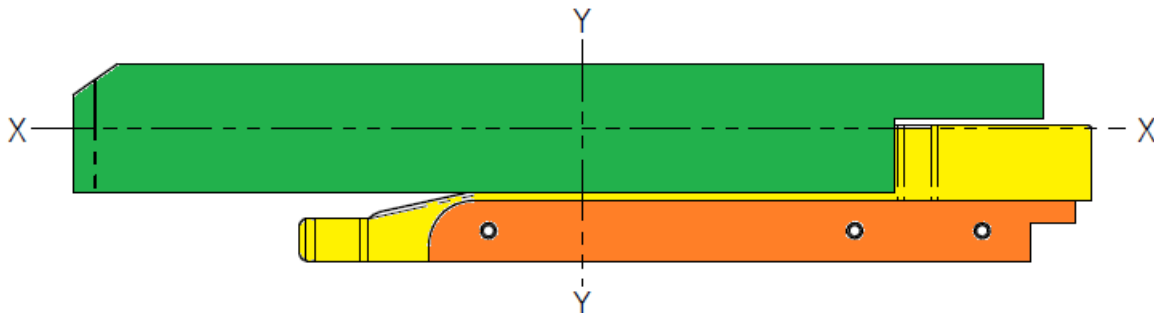

Service Instructions

2. Top Conveyor Adjustment

A. Alignment

The top conveyor should be perfectly aligned with the folder.

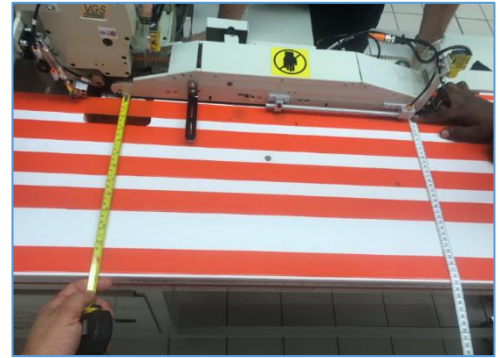

B. Position

Set the top conveyor parallel to the folder and the edge of the table top. The right edge of the right belt should be positioned over the gap between the folder edge guide and the right edge guide. However the belts must not rub the presser foot on either side.

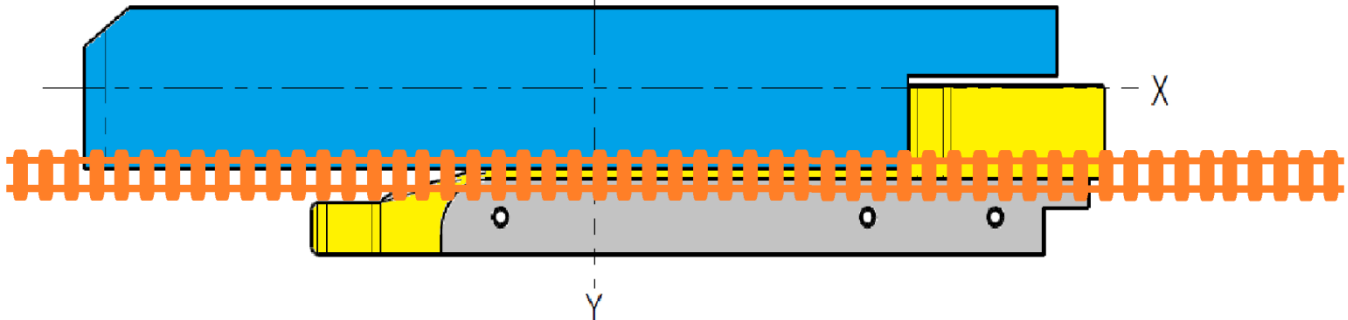

C. Level

Carriage should be leveled with the machine table in all direction

1. Height

The height of the carriage is adjusted that both belts should have contact with the Lexan plates and should be held down against the folder and the table with the pressure of the Lexan plates.



3. Sewing Head

A. Pre-set chaining tensions

Pre-set the chaining tension. Adjust to ensure a smooth chain-off without skipped stitches. Sewing tensions are located above the chaining tension on the tension assembly with the cylinder controlling the opening and closing of tensions during sewing and chaining. Adjust to quality specification.



Set up according to factory specification. 100% cotton may require adjustments on looper take-up timing and thread handling components. Cotton thread requires less looper thread in the stitch because thread has no stretch. See cotton setup enclosed in the sewing head setup instructions.

Service Instructions

B. Presser Foot Height

Foot-lift height should be set with the unit stopped at top dead center position.

Press Set Up, go to Advanced Manual, go to Hemmer, press the Foot lift button, and set the height adjustment screw located on the foot lift mechanism to raise the presser foot up off of the feed dogs approximately 1/32". Lock the wing nut after adjustment.

In its maximum upper position the outside sole of the presser foot should stay in touch with the stitch plate. A small clearance should be present in the inside part of the presser foot.

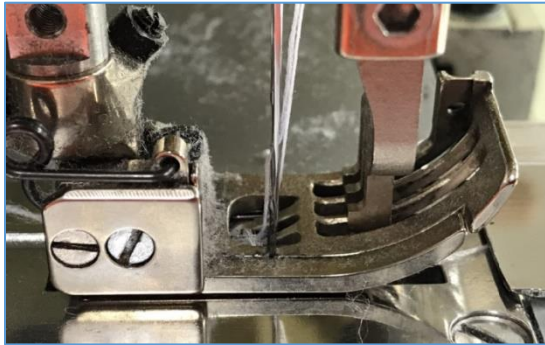

DOWN

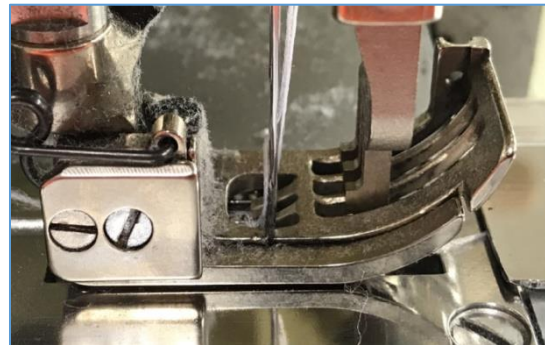

UP

Adjustments are made with the limit screw (A)



C. Feed Adjustments

1. Remove top feed belt and folder
2. Lift puller and keep it lifted through this part of the adjustment.
3. With the top belt, without any puller interference use 2 pieces of material 2 inches wide x 20 inches long. Perfectly align the 2 pieces off material and introduce it under the presser foot.
4. Sew it using "SEW" button on the Hemmer Manual page.



5. Check Stitch count to match specifications



Too much feed in the bottom

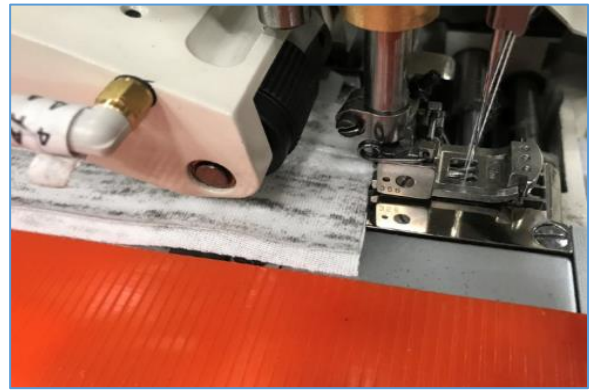

Correct top and bottom feeding

Material should be aligned from the beginning to the end. If this condition does not happen adjust top feed to make this happen. A complete flat seam needs to be achieved without the belt feed or the puller feed.

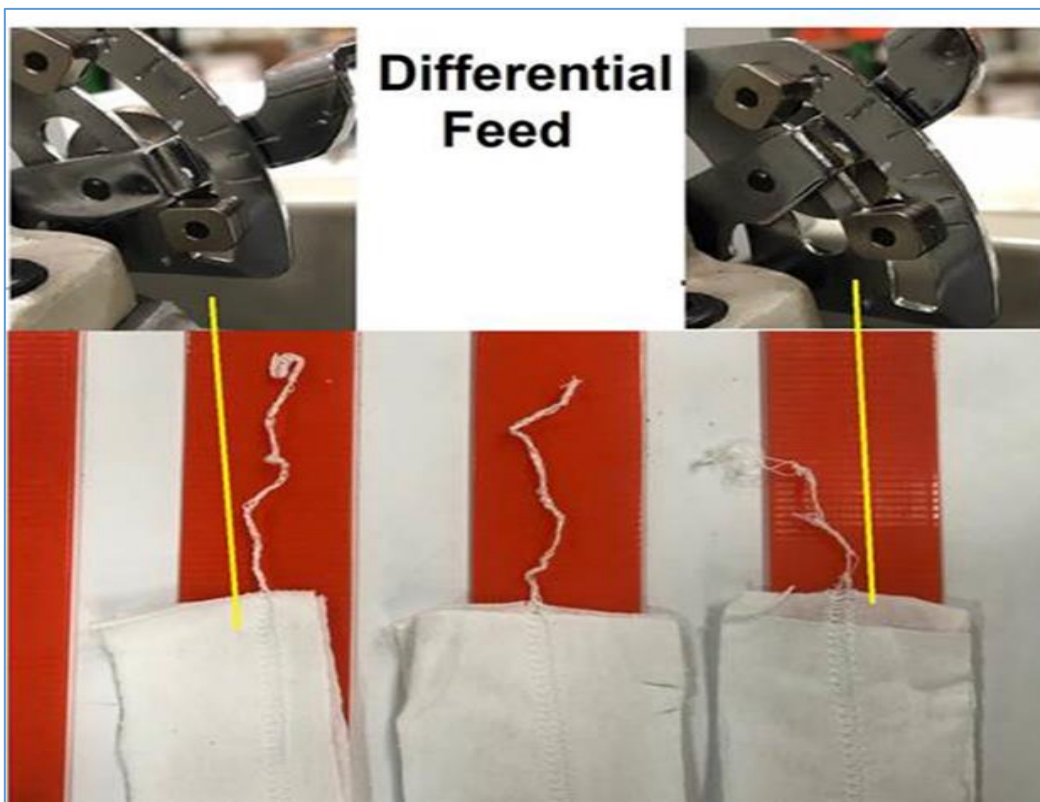

Low value

Right feed

Too Much value.

Service Instructions

Seam must be flat and nice from the beginning to the end. If this condition does not happen adjust sewing head, calibrate thread tension, calibrate feeding, inspect throat plate for any burrs, etc.

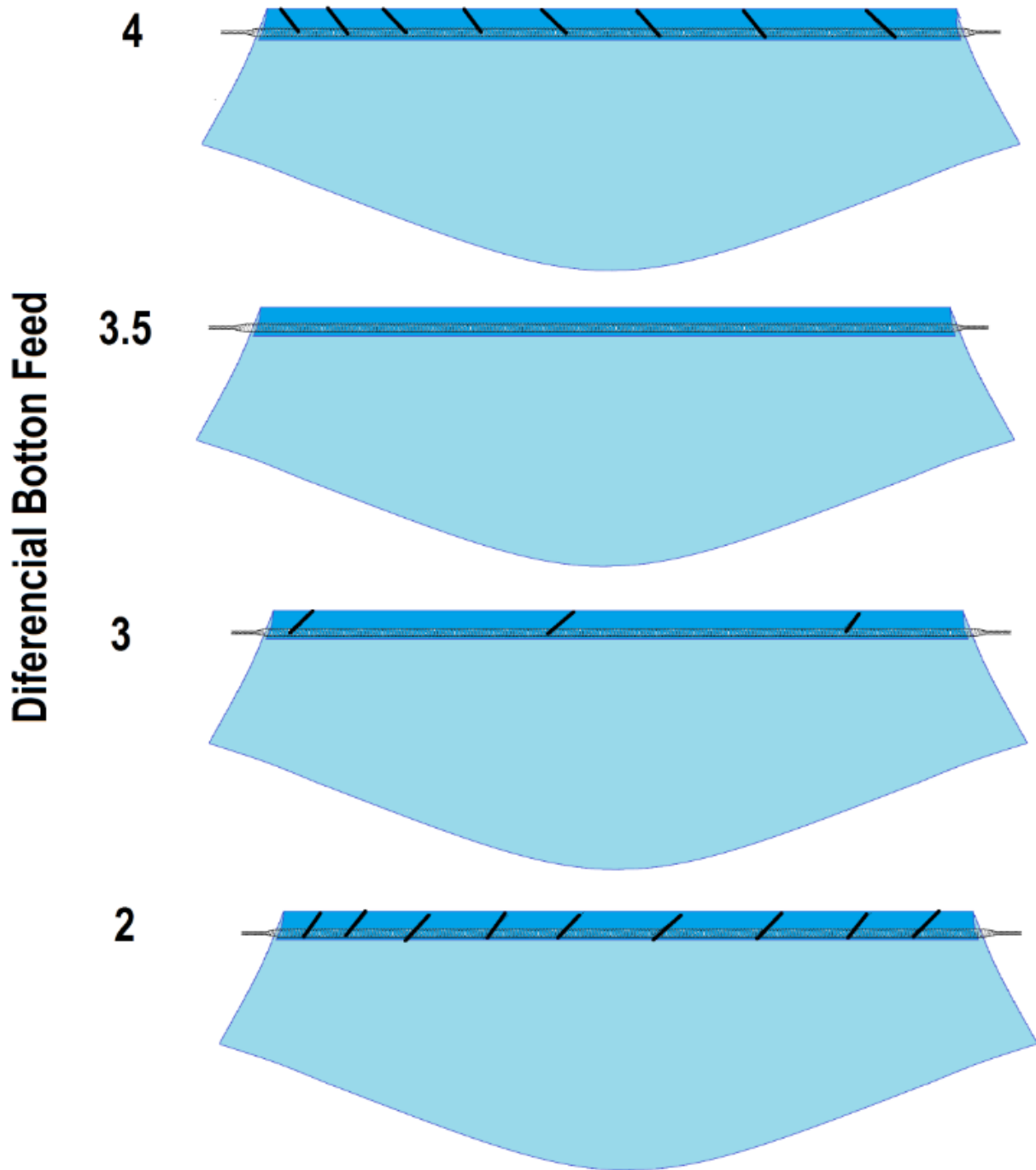

Service Instructions

Puller Adjustment

Assembly/disassembly:

Chain puller must be assembled to have little to no axial play in shafts, as they are tightened and secured to proper adjustments.

There are two adjustments that can be made to the chain puller: height and levelness.

Height Adjustment.

Actuate the manual puller lift and set the puller so that there is 1/2" clearance between the puller roller and the chaining plate. This adjustment is made by loosening the two socket cap screws and positioning it so that the proper clearance is obtained. (1, Fig. 2)



Level Adjustment.

After the proper height adjustments have been made the puller roller must be set so that it is level with the chaining plate. This adjustment should be made with the power OFF. With power off, the roller must turn freely. This adjustment is made by loosening the two mounting screws located on the front of the main assembly. Take note as you torque down the screws, the puller will sometimes move as proper torque is acquired. Recheck clearance between the puller and the puller chaining plate after tightening the screws. Loosen the two 5/16-18 hex cap bolts (2, Fig.2) that secure the puller to the mounting bracket.

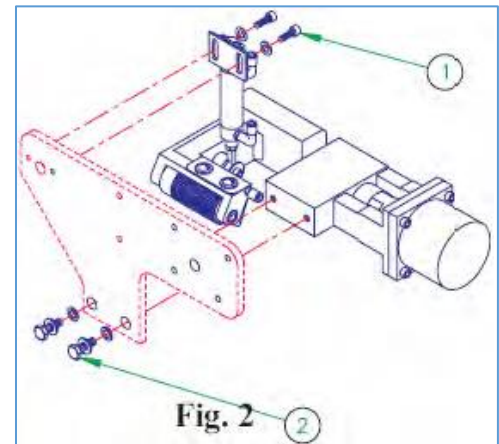

It may or may not be necessary to raise or remove the presser foot to make this adjustment.

When the roller is level with the chaining plate tighten the two hex cap bolts

Care should be taken in making this adjustment, as an improper adjustment may cause thread breakage and skipped stitches during the chaining process.

Speed Adjustment

The AP-28-620B stepper box located on the lower frame controls the speed of the puller.

Set the puller sewing speed so the Hemmer makes a flat, straight hem. Set the chaining speed just fast enough that the chain is pulled straight out from the center of the back of the presser foot during chaining. This speed is usually 30% to 60% faster than the sewing speed depending on the stitch length and needle gauge. When using cotton or spun polyester thread, the puller speed should be about 20%-25% faster than its sewing speed.



Service Instructions

Chain Cutter

NOTE: This is a very important step! All adjustments must be made as accurately as possible.
* Remove upper conveyor, folder and raise sewing head * Remove puller, knife assembly and gauge parts A. Use related technical information on setup specifications See Yamato, Pegasus or Rimoldi text.

Assembly

- Fasten the drive link to the clevis using the shoulder screw with felt wick, soaked in sewing machine oil, and tighten with elastic nut. The clevis clamp screws should be loose.

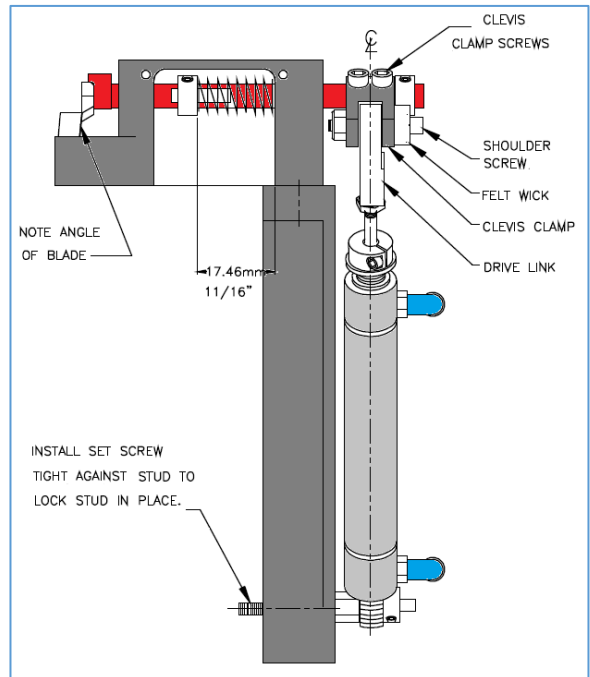

NOTE: The cylinder must be parallel to the bracket to prevent binding.

- Assemble so that the mount block and Clevis surface are parallel when the shaft of the cylinder is at its full length

NOTE Install Stud with Blue Loctite & tighten securely

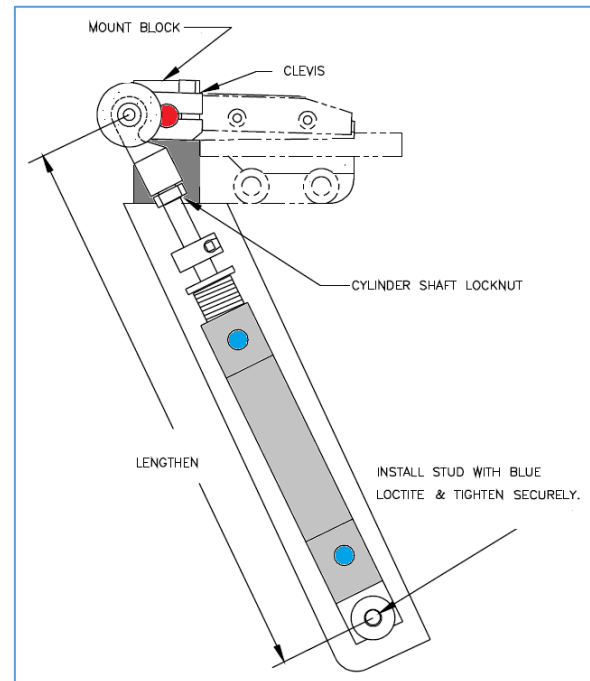

Stroke

- Adjust movable blade tip at 1/16" past the surface of stationary blade. This sets the closed height.

NOTE: These last 2 adjustments must be held true throughout for the trimmer to cut cleanly.

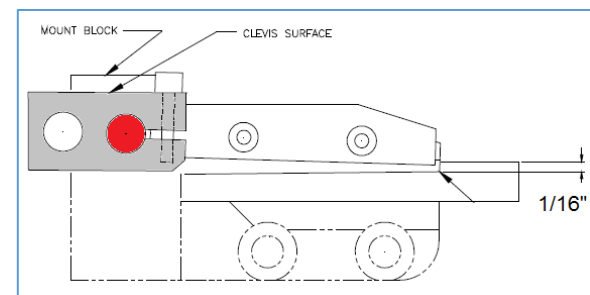

Service Instructions

Raise the movable blade and adjust to 3/4" opening so that the hem of the sleeve does not hang in the V groove of the knife in the up position.

The clamp collar on the air cylinder sets this height adjustment.

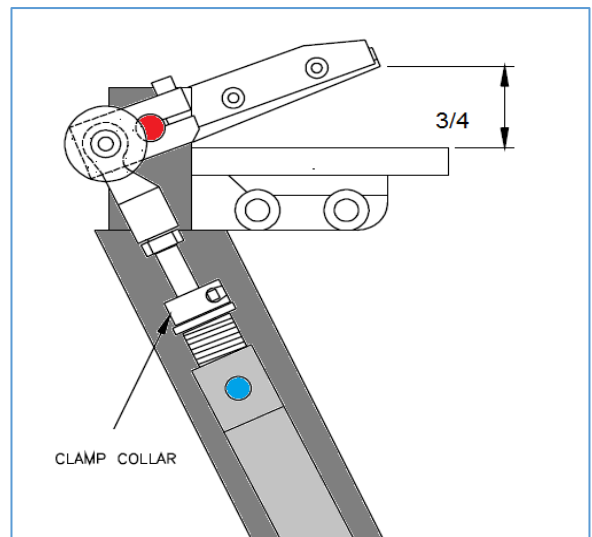

Shear Set

The spring pressure should be adjusted so that the knife will cut with minimum spring pressure. Factory setting is that the set screw in the collar is set to the end of the flat cut in the knife shaft.

The shear should be set on bottom blade for .003". Lower knife has 2 cutting edges, so the knife can be turned over for new cutting edge.

- Loosen Screws on Stationary blade.
- Place .002 - .003 gauge as shown.
- Close opposite end of stationary blade & tighten Screws until it is locked in place.
- Test with material for clean cut.

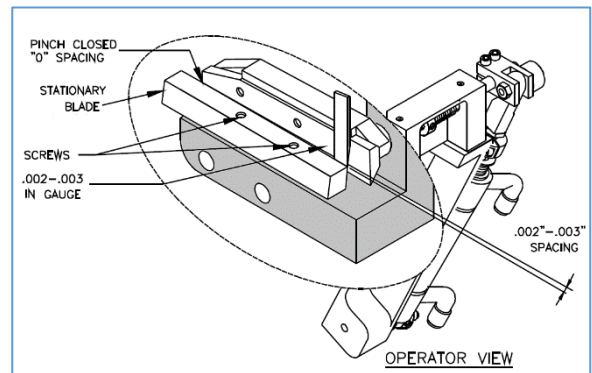

Position

The left to right adjustment should be set so that the chain vacuum hole is centered on the needle gauge. Take note the chain will sometimes move during chaining. More adjustment to the outside may be necessary to insure vacuum captures thread chain during chaining. Make sure chaining plate is flat to sewing head. Approximately 3/8" of blade should extend past the center line of the chain.

Sewing Head Position

The position of the seam in reference to the folding edge is set by moving the position of the sewing head. To adjust, move the sewing head left or right after loosening the 2 screws that hold the sewing head mount plate.



When you run light materials, you will need to leave a 1/16 to 1/8 of material outside the left needle.

For regular weight material you can hide the cutting edge between the needles

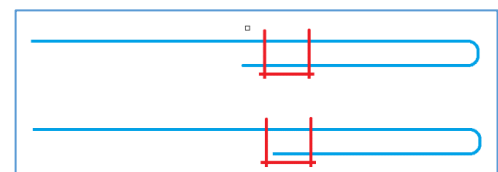

Service Instructions

C. Stitch Length

Stitch length can be set in manual sew. Take note to set stitch length to specified spi as it is important for proper set up. Some material may require more or less differential feed.

Adjustment

The stitch length can be adjusted using the knob on the front of the machine.

The Stitch length without the influence of the puller should be 10% smaller than the final stitch length required.

1. Press the puller up valve to keep the puller up.
2. Place material under the foot.
3. Press the SEW button to sew a seam to measure the stitch length.
4. When the end of the material gets to the foot, press CHAIN and pull the material until the material clear the thread knife.
5. Press CUT and check the stitch count on the sample.
6. Adjust the stitch length knob and sew another sample if needed.
7. When desired stitch count is achieved, move the puller pressure airline back to the top fitting.
8. Place material under the foot to begin setting the SEW puller speed.
9. After the first stitch is accomplished drop the puller and run the unit on "SEW" mode. Puller must pull the material gently and increase the stitch length 10%.
10. Adjust the puller Sewing Speed if required.



Example: If the stitch count without the puller is 11, with the puller, it should be 10.

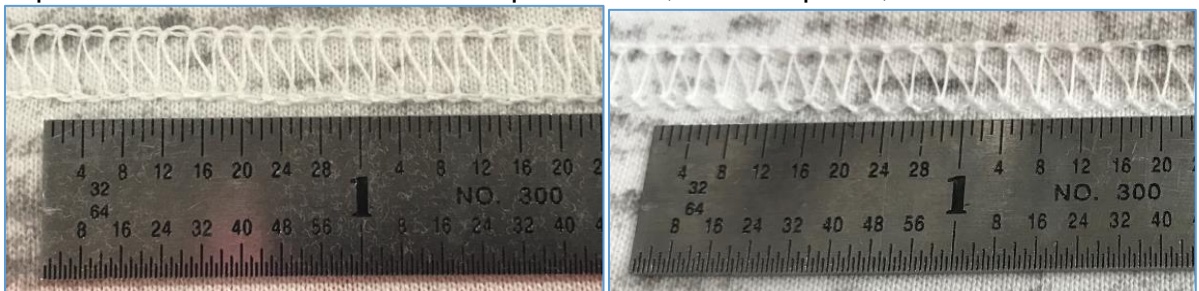

11. Run the sewing head on "CHAIN" mode without sewing material.
12. The Chain puller speed should be at least 20% higher than the puller sewing speed.

Example: If the puller speed is set to 80 in the control box the chaining speed should be set to 100.

The machine should be chaining correctly with a uniform chain.

If this condition is not happening, make sure the puller pressure is activated and the puller is pulling the chain while sewing. Inspect the throat plate for any damage, and the bridge, under the throat plate that helps the chaining, does not have any damage.

D. Needle distance

The distance is defined by the sewing components of the machine. The most common are 6.4 mm and 5.6 mm.

2. Folding Station Adjustment

A. Folding Plate / Air Folder Adjustment

A. Folding plate must be set level, and 1/4" above the surface of the belts.

This plate is factory adjusted and should not need to be readjusted. In case this adjustment has been changed, the following procedure will properly realign and level the plate. Loosen four side mtg. screws and lift the plate up. Insert a 1/4" thick and approximately 4" wide x 12" long (or any other suitable size) spacer plate under the fold plate. Let the fold plate rest on the spacer plate and while lightly pushing down on the top of the fold plate snug all four mtg. screws to secure the fold plate in place. Pull the spacer plate out. Tighten all mounting screws.

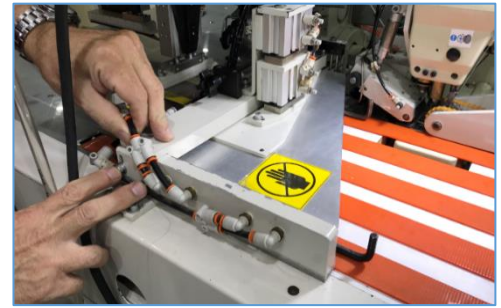

B. Folding plate must be set perpendicular to the hem.

Again this adjustment is factory set, but in case it is misadjust, following procedure will set the folding plate to the correct position. Loosen the four screws mounting the fold in half mechanism to the hemmer. Tighten one of the screws close to the outside of the machine. This will allow the whole mechanism to pivot about this screw. Next, move the folding plate around to get an equal distance from the edge of the tabletop, to the fold edge of the folding plate, on both ends of the plate. Tighten all screws.

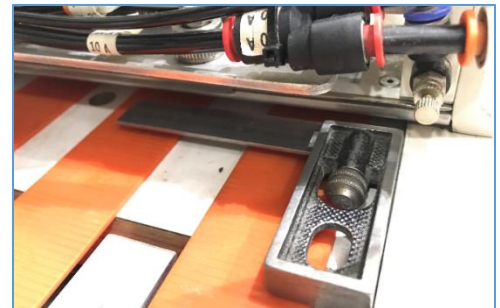

C. The folding plate has two internal air channels which form air folder blowers.

- One supports the hem portion of the sleeve,
- The second supports the body portion of the sleeve.
- There is a third channel inside, the uncurler blade, designed to blow below the top ply during leading edge folding, so that any underside curls will be uncurled before clamping.

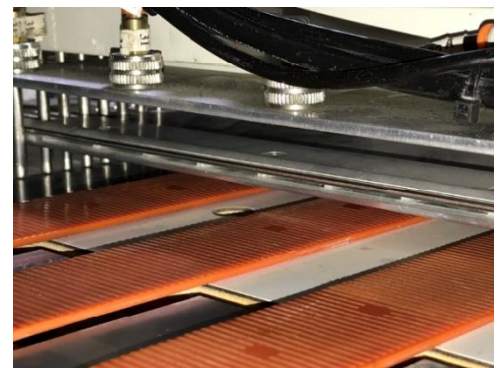

To control the air distribution properly, the air flow to the folding plate/air folder has two flow controls. (See Air regulator Cabinet Page: 53)

- The first flow control regulates the flow through the hem and body side of the folding plate channels. It should be adjusted so that the top and bottom plies of the sleeve are separated. The edge alignment will be affected if the plies rub each other.
- The second flow control is used to control the air flow from inside of the uncurler blade. The flow should be about half open to allow air to prevent an under curl from forming. The air source for this blower is taken from the body air jets, so this flow control should never be open more than halfway, otherwise the air flow supplied to the body air jets may not be adequate.

Service Instructions

B. Air Jet/Clamp Plate Adjustment

A: The air jet/clamp plate has three operating positions, and is factory adjusted to the following dimensions:

- Position #1, fully open 11/16" above folding plate
- Position #2, align gap 1/4" above folding plate
- Position #3, clamp just touching the top of the uncurler blade.

Do the following to reset them if set incorrectly.

- First adjust the align gap by fully extending the top cylinder (1) and almost fully unscrewing the two stop (2) screws from the top of the cylinder.
- Insert a 1/4" thick plate between the top surface of the cylinders mounting plate and the bottom of the cylinders body (4).
- Retract the cylinder with the spacer in place and screw both stop screws (2) until they rest on the top of the cylinder guide rods.
- Lock the jam nuts, extend cylinder, and remove the spacer plate.

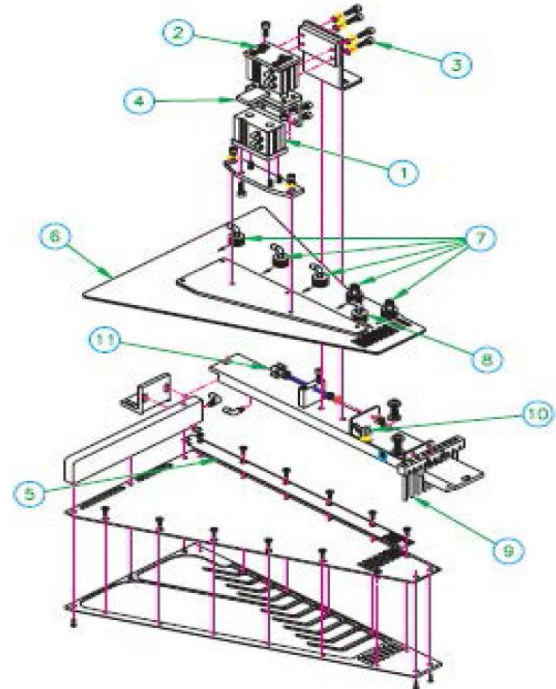

To adjust the clamp position.

- Loosen the four (3) mounting screws that mount both cylinders to the frame and extend both cylinders.
- Rest the clamp on the uncurler blade (5) without applying any pressure. Make sure that the clamp plate (6) makes contact with the uncurler blade across the entire length of the clamp,
- Lock the four mounting screws (3).

The flow controls controlling the speed of the two cylinders that operate this clamp, are factory set for a smooth, long-lasting operation of this mechanism.

B. All air jets on the clamp plate (7) must point straight back in order not to affect the hem alignment. The first two air jets are called hem jets since they fold the hem side of the sleeve. The back pressure indicator gauge for this set of jets should be set to 30 to 35 psi, when the override on the corresponding valve is depressed (machine not running). The three outside jets, called body jets should be set to 15 to 20 PSI.

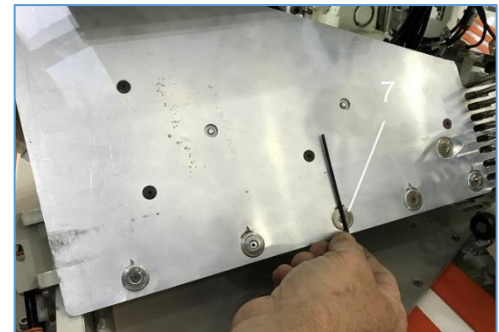

C. Top ply alignment jet (8) mounted on the clamp plate, is factory adjusted to point perpendicular to the hem. The air back pressure should be set to 10 to 15 psi, in a similar manner as the hem and the body jets. This adjustment depends on the sleeve size, for larger sleeves use more pressure, for smaller use less.

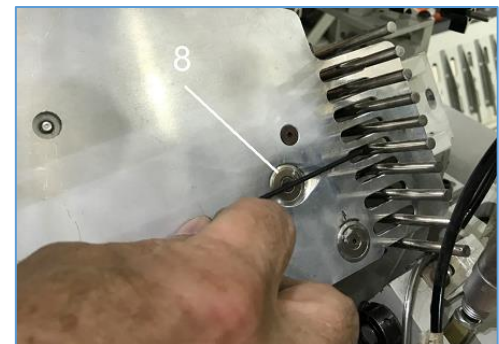

Service Instructions

C. Hem Alignment Guide Pins Adjustment

Hem alignment guide pins (9) are set to the bottom of the hem. This can vary from material to material, so provisions were made for easy operator, or mechanic infield adjustment.



The adjustment procedure is as follows:

- Loosen the clamp handle (10) and with adjust the pins back beyond the hem line.
- Start the machine and hem a sample sleeve to be sewn.
- Let the sleeve hem until it is just about ready to be folded in half.
- Stop the machine by pressing the Pause button on the screen and adjust the pins to almost touch the edge of the sleeve.
- Lock the new pin location by tightening the clamp handle (10).

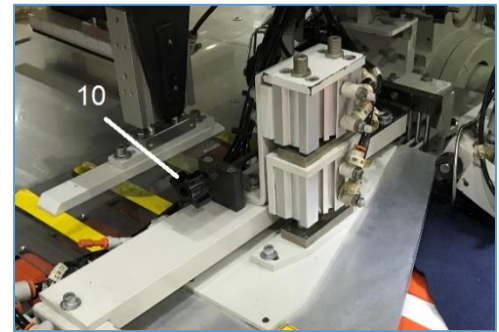

D. Bottom Ply Alignment Jet Adjustment

The bottom ply alignment jet must point in the direction perpendicular to the hem. Its purpose is to maintain sleeve alignment against the guide pins. The air back pressure should be set to about 20 psi (adjust if necessary, in a manner similar to the one described above for adjustment of the top ply alignment jet in 2B, C)

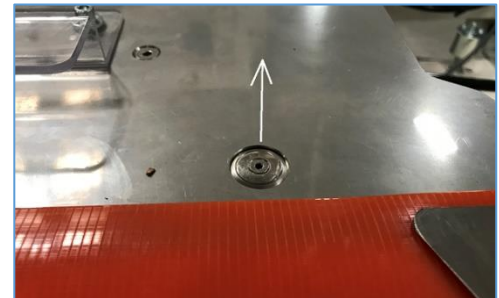

E. Skid Plate Adjustment

The skid plate should be adjusted left to right, so that it lays as close to the top conveyor as possible, to cover and hold the sleeve on the belts. This will keep the sleeve in a uniform position as it is being folded in half.

The front to back adjustment depends on the amount of the sleeve being clamped in the folding clamp.

The relief bend in the skid plate should line up directly below the location of the leading edge of the sleeve. This alignment is necessary so that when the sleeve is taken away by the transport #1 clamp, it is no longer held between the skid plate and the belts. If this plate is not in the proper location, the sleeve will snap during the transport, and cause bad hem misalignment, or unusual folds or curls.

The relief bend should occasionally be checked to make sure that it has proper clearance above the belts (about 1/16). If it appears not to have the proper clearance, it needs to be slightly bent at the leading-edge bend. Also make sure that the bend is not too severe, since if the top of the pressure plate in the area of the relief bend touches the bottom of the fold plate, it will result in too much pressure on the belts and the sleeve, causing unpredictable alignment problems, or even conveyor belt stalling.

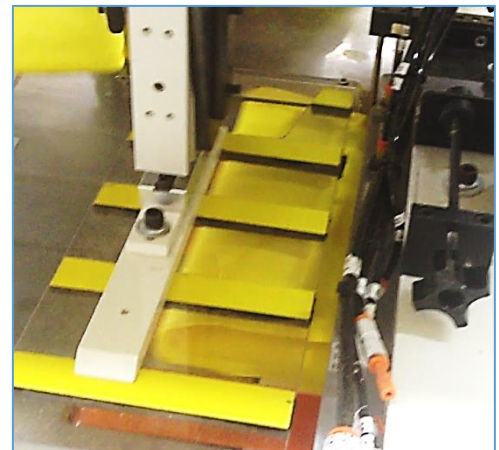

Service Instructions

F. Transport 1 Clamp Cylinder.

When the Transport 1 Clamp Cylinder is fully extended, the clamp pad should just lightly touch the table. Adjust by moving entire cylinder up/down. Do not to adjust too tight. This will cause excessive wear on the rubber pads on the bottom of the clamp pad. Note that the rubber pads must rest between the conveyor belts.

Adjust the Transport 1 Clamp Cylinder “stop” so that the cylinder has 1-3/4" of stroke. With the transport clamp and the pick-up head both in their up positions, set the Plexiglas shield on the back of the pick-up head to be flush with Plexiglas part of the transport clamp. Be sure that the ply separator does not hit the shield on the sleeve pick-up head, the top part of the ply separator must slide under the Plexiglas shield.



G. Transport 1 Cylinder.

The adjustable stop at the right end of the #1 Transport Cylinder is used to adjust the amount of trim-off that the Seamer will have. Adjust the shock absorber for quiet operation. (FIH Mode) Make sure the proximity switch on the stop block is made when the transport reaches it.



H. Transport 2 Clamp Cylinder.

Lay an unhemmed folded sleeve under the Transport 2 clamp. Extend the clamp cylinder. Adjust by loosening the two mounting screws located on the cylinder and lower the whole cylinder until the clamp contacts the sleeve. Do not adjust too tight. This will cause excessive wear on the rubber pad on the bottom of the clamp pad. Adjust the “stop” on the cylinder so the cylinder has 1-1/8" of stroke. Adjust the position of the cylinder that operates the extendible tongue so that the tip of the tongue will not hit the Seamer edge trimming knife when the tongue passes under the seamer presser foot.



I. Transport 2 Cylinder:

The adjustable stop at the end of the Transport 2 cylinder is used to adjust the stop position of the sleeve at the Seamer presser foot. Adjust so the sleeve stops under the Seamer foot with the Seamer start eye covered. If this stop is adjusted, be sure the proximity switch is set to activate at the end of the cylinder stroke. Adjust the shock absorber for quiet operation.

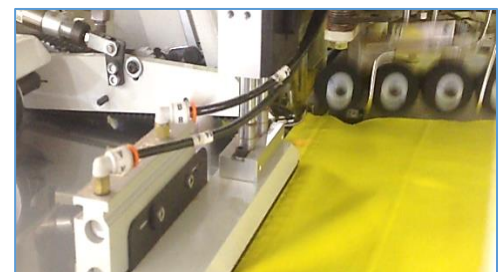

Service Instructions

J. Proximity Switch Adjustments.

The proximity switch “A” on transports 1 & 2 should be activated when the cylinder carriage stops against the stop block mechanism. Set the proximity switch so that it lights up when the cylinder is against the stop block. When transport 2 is at its home position, the home proximity switch LED should be on.



K. Rotate cylinder function and adjustment.

Transport 2 has a rotate mechanism that allows you to sew straight seams. This mechanism is calibrated in 5-degree increments. Set the angle according to the pattern to be sewn.

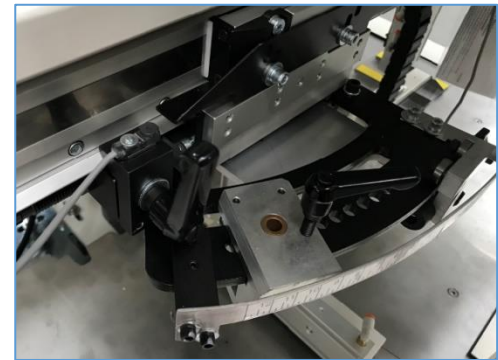

L. Seam Guide Wheels

They are located in front of the seamer. They are responsible for the guiding of the material before closing. The guide wheel timing can be modified by parameters #40 & # 41 on the screen. The amount of taper can be modified mechanically. It will define if the closing seam is straight or tapered.



**Straight
Not Activated**

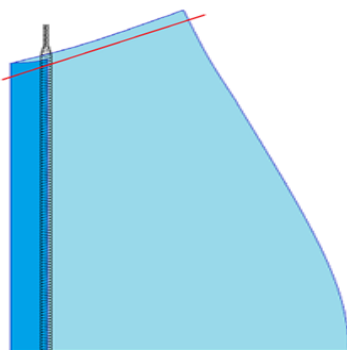

**Taper
Activated**

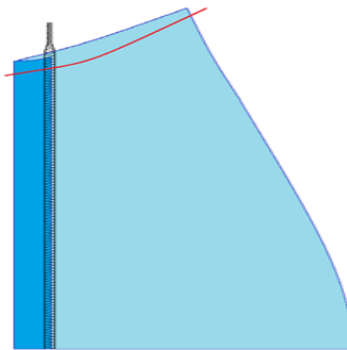

M. Flow controls.

Flow controls are set from the factory. If adjustments are necessary, they should be set to allow smooth low impact movements in order to ensure long life of air cylinders and components. Operate unit to test previous set-up and adjustments.

N. Air Regulators Top Cabinet

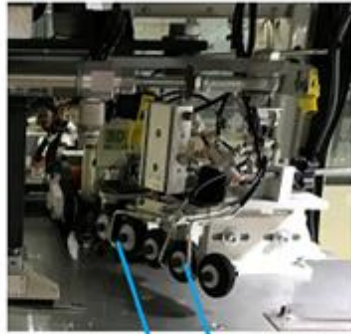

Seamer Guide
Blowers

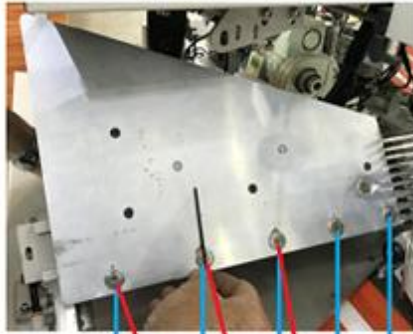

30psi
Leading edge
Jets Body

60psi
Leading Edge
Jets-Hem



Air Folder
Blower

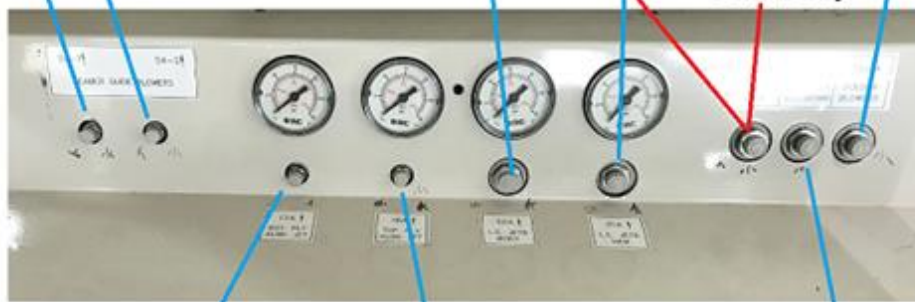

Trailing Edge
Jets Body

Bottom Ply
Align Jet
30psi

Top Ply
Align Jets
30psi

Transfer #1
Slow Down

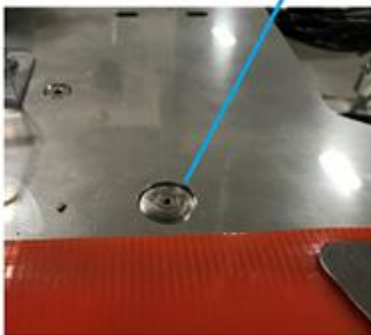

3. Seamer Adjustment

CAUTION: There is a thread trimming Cutter located behind the presser foot. This Cutter operates automatically and manually. DO NOT put fingers or hands in or around this Cutter. All sewing adjustments to the sewing machine head should be made with the main power "OFF".

A. Seamer Air Supply Setting:

A. The Seamer air regulator should be set to 80 PSI. This regulator controls the pressure to the back latch venturi air tank. The air pressure to the Seamer solenoid valves is controlled by a second non-adjustable regulator factory preset to 65 PSI.



B. Tension Opener:

A. Check needle thread tension opener for proper operation.



C. Seamer Conveyor Height Adjustment

A. The side conveyor should be 1/32" to 1/16" above the skid plate depending on the material thickness.

This adjustment is made using the height adjustment knobs on the support weldment. The belt must not contact the plate.

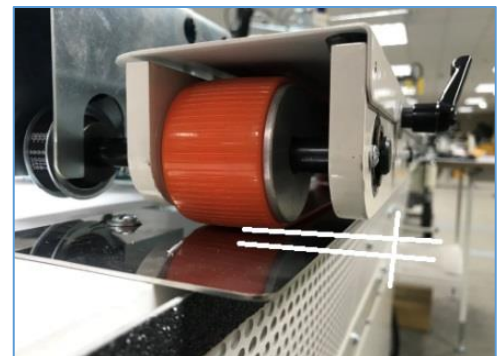

D. Seamer Conveyor Spring Pressure

A. Set the spring pressure to balance the weight of the conveyor by approximately 25-50%. If the conveyor stalls, decrease the pressure by turning the spring pressure knob clockwise. If the conveyor slips on the garment, increase the pressure by turning the pressure knob counterclockwise.



Service Instructions

E. Front Belt Feed Conveyor

A. The front belt feed conveyor should be set at a height so that it just contacts the cloth plate. When the height is properly adjusted, material under the feed belt cannot be easily pulled from under the belt. This adjustment is made by loosening the nut on the air cylinder rod and rotating the rod. When the proper height is achieved, tighten the nut. The flow controls on the air cylinder should be adjusted to ensure smooth operation of the front feed belt.

B: The tension of the belt can be controlled by the tension pulley adjustment slot. To release the cylinder, just push the cylinder out and raise it up.



Loosening the screw and moving the pulley up or down will increase or decrease the tension.

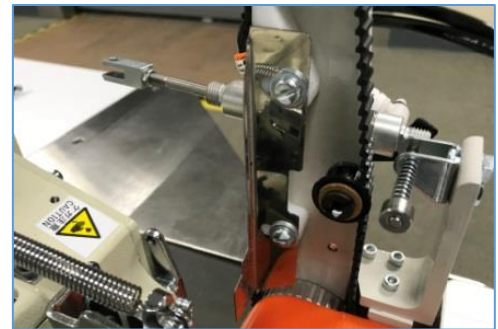

F. Back latch

It is responsible for a clean sewing beginning. The automatically controlled vacuum generator draws the chain from the previous piece toward the operator into the hollow chaming tongue as the chain is sewn into the seam. Operating sequence:

- Transport 2 inserts the garment under the presser foot as close to the needle as possible.
- Machine cycle starts.
- Vacuum comes on.
- Stitching begins.
- Vacuum shuts off.

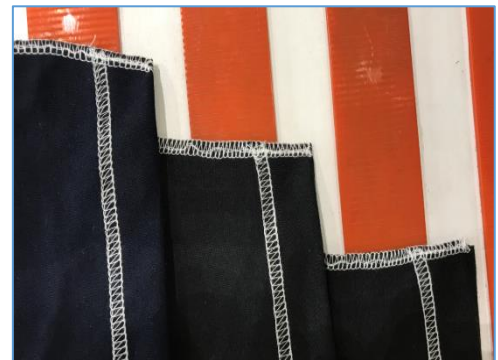

Service Instructions

NOTE: The length of the back latch is determined by the amount of chain produced before the sleeve reaches the needle.

After the machine stops, check the needle stop position. The upper looper should be in the upward stroke just at or past the eye of the lower looper.

NOTE: This means the needle is not in the highest position. The chain will be drawn into the tube by the vacuum after the cut signal.

6. Another sleeve can be sewn now.



G. Chain Trimmer:

A. Check chain trimmer function.

- ① ATTENTION / ATENCIÓN
MAKE SURE THAT CUTTER SHAFT DOES NOT BIND INSIDE BODY.
ASEGURESE QUE EL EJE NO SE ATASCA DENTRO DEL CUERPO.
- ② ASSEMBLE LEAVING SCREWS SLIGHTLY LOOSENED ON LOWER CUTTER (SCREWS NOT SHOWN FOR CLARITY)
ARME DEJANDO LOS TORNILLOS FLOJOS EN EL CORTADOR DE ABAJO. (LOS TORNILLOS NO SE MUESTRAN POR CLARIDAD.)

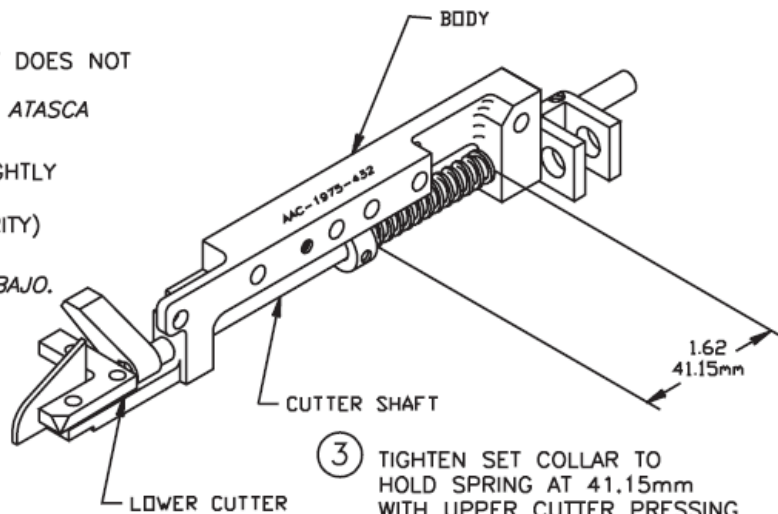

- ③ TIGHTEN SET COLLAR TO HOLD SPRING AT 41.15mm WITH UPPER CUTTER PRESSING AGAINST LOWER CUTTER
APRIETE EL COLLAR PARA MANTENER EL RESORTE A 41.15mm CON EL CORTADOR DE ARRIBA PRESIONANDO CONTRA EL CORTADOR DE ABAJO.

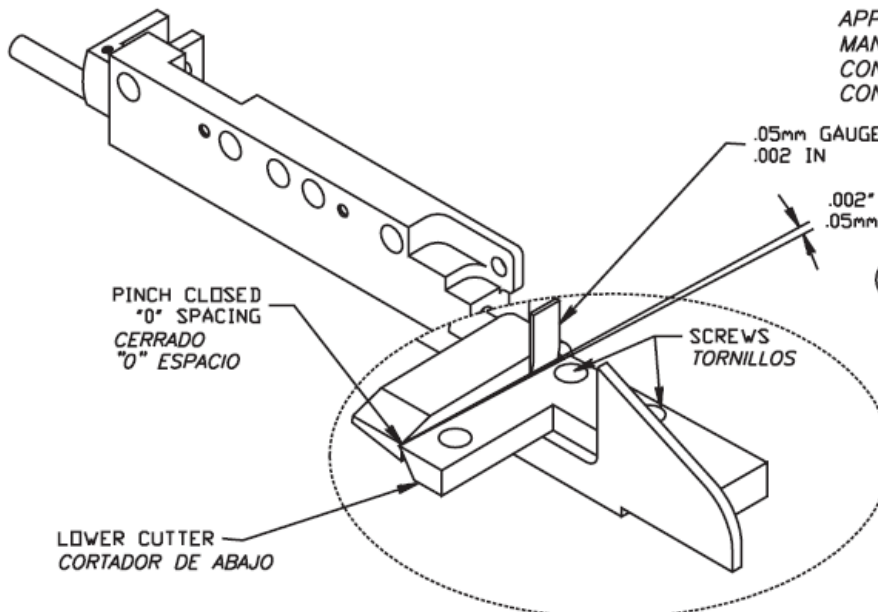

- ④ SET SHEAR AT .05mm AND TIGHTEN SCREWS ON LOWER CUTTER UNTIL IT IS LOCKED IN PLACE
FIJE EL CORTE A .05mm Y APRIETE BIEN LOS TORNILLOS EN EL CORTADOR DE ABAJO.

CUTTER ADJUSTMENT INSTRUCTIONS

Service Instructions

H. Seamer Waste System:

A. The Seamer waste system turns on when the needle thread tension opens during chain-off. The waste Venturi stays on for an adjustable time set by timer Seamer Waste System On time (Screen Setting Seamer 9). This timer should be set long enough to carry the trimmings all the way to the waste can.

NOTE: The time interval of the vacuum “on” is only long enough to capture the stitch chain and sew past the vacuum tube at the rear of the throat plate. To change this time interval refer to the ADVANCE SETTINGS 1 chain vacuum on time. Upon completion of sew, the machine cut the chain automatically.



I. Vacuum Ejector Assembly Maintenance:

NOTE: The air supply to the ejector should be a minimum of 4SCFM at 80 PSI.

A. Check air supply by observing pressure gauge while pressing manual cut button. The pressure drop should be no more than 2-3 psi.

B. Check for clogs in the vacuum generator by removing the assembly from the frame, noting how all connections were made. Remove Part AAV#33-4 from the assembly and remove thread if necessary. Clean unit as thoroughly as possible and reinstall. Ensure all fittings are tight and do not leak, but do not over-tighten.

C. Check air line connections from vacuum generator to the throat plate to ensure there is a tight seal.

D. Check air line between the throat plate and the vacuum generator for clogs, etc. Replace if dirty.



4. Stacker

A. Trap Door adjustment

The Stacker Trap Door adjustment is accomplished by using the stop collars and cylinder rod ends under the stacker trap door. In the up position, door should be .005 below seamer cloth plate. In the lowered position, seamer door should be adjusted so that door does not contact conveyor belts.

B. Transfer wheels

The Transfer wheels should be adjusted so they contact conveyor belts evenly when the trap door is down.



C. Stacker door adjustment

The stacker door should be adjusted in the closed position by moving the stop plate and the clamping collar on the stacker door cylinder. In the up position, door should be 1/8" from belts when collar is bottomed out on cylinder nose.



D. Eye adjustments and positions

A. Eyes should be adjusted as previously noted. There are 3 eyes on the stacker; start stack, stacker eye and stacker full eye. (See Page 76)



E. Flow controls

A. Flow controls should be adjusted to obtain smooth low impact motion. Stacker door should be fast enough to obtain consistent stacks.

3.3. Pneumatic

NOTE: All maintenance should be performed by a qualified service technician.

1. Air Filters

Clean air from your compressed air system is essential for the safe and efficient operation of this equipment. This unit has 2 compressed air filters. They remove contamination from compressed air after compression has taken place. Harmful contaminants like oil, dust, dirt, rust, and water, alone or in combination, can attack your system and clog sensitive pneumatic parts.

- It can reduce the efficiency of the unit.
- Wear out seals and erode system components.
- Increase maintenance and repair costs.

Air leaving a standard screw or piston compressor will generally have a high-water content, as well as a high concentration of oil and other contaminants.

Condensate is drained manually by pushing the red button on the drain plug. They require a regular maintenance schedule (i.e., once per shift).



2. Pressure Regulator

The purpose of the regulators is to keep the operating pressure of the system virtually constant regardless of fluctuations in the line pressure (primary pressure) and the air consumption.

There are 5 pressure regulators inside the lower cabinet with their respective gauges.

1. Guide Wheel

Amount of pressure on the guide wheels.
Pressure needs to be set from 15 to 20 Psi.

2. Transport Clamp

Amount of pressure on the transport clamps
Pressure needs to be set from 15 to 20 Psi.

3. Hemmer

Air pressure for the hemmer section
Needs to be set to 80 psi.

4. Fold in Half

Air pressure to the fold in half section
Needs to be set to 80 psi.

5. Seamer.

Air pressure for the seamer section
Needs to be set to 80 psi.



Service Instructions

3. Solenoid Valve Stacking Manifold

Control System voltage is 24 VDC. A red light means the valve is energized

Each valve can be activated manually by pushing the blue button.

There are 3 manifolds on the machine. The first one is located inside the lower control panel.

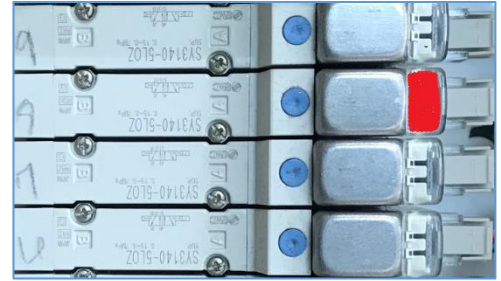

The second one is located on top of the Folding / Transport station.

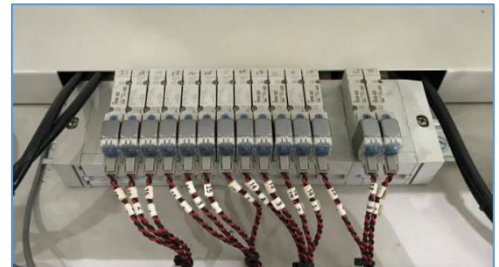

The third one is in the seamer / stacker station.



4. Air Pressure Switch

There are 2 pressure switches. One is located inside the control box. This Sensor is responsible for the detection of the secondary air pressure if it does not reach the pre-adjusted value. The pre-adjusted pressure is 70 psi. The other one is the foot lift safety switch. Located in the top cabinet, it is monitoring the presser foot position. If the presser foot is up, the sewing machine will not run. For more details of connections see the plumbing and wiring diagrams located at the end of the manual.



5. Waste Venturi

The purpose of the waste venturis is to pull the trimmings away as they're cut off of the sleeve. The air flow should be enough to get the material from the knife to the waste can.

- If it is set too high, it will pull the edge of the sleeve and hold it.
- If it is too low, it will not pull the cut material into the trashcan.
- The Seamer waste has an additional parameter under seamer settings in the computer which allows the user to change the venturi on time.



6. Blowers

A. Front of Top Conveyor.

It helps to uncurl the material edge before it arrives at the upper conveyor.

The air flow should be enough to uncurl the material as it passes the air jet.

If it is too low, the material will remain curled up and may get sewn into the seam curled.



B. Front of the Trimming Knife.

It blows the material flat before the edge is cut by the edge trimming knife. Set height according to the material thickness.

C. On the side of the Top conveyor.

It blows the sleeve flat against the table conveyor before it goes under the skid plate and into the fold in half section.



D. Fold In Half Entrée

It blows the sleeve flat against the table conveyor before it goes under the folding station



E. Seamer Guide Wheels

It keeps the top edge of the folded sleeve flat before it goes under the seamer presser foot.



Service Instructions

7. Sophie Air Jet

Unit has several available. They are activated by solenoid valves.

Their function is to help to guide the material in the sewing process.

Air flow can be regulated on the flow controls directly on the air jet. The direction of the air flow can be controlled by loosening the nut and rotating the body of the air jet.



A. Clamp plate

Its purpose is to maintain sleeve control when it goes through the clamp plate.

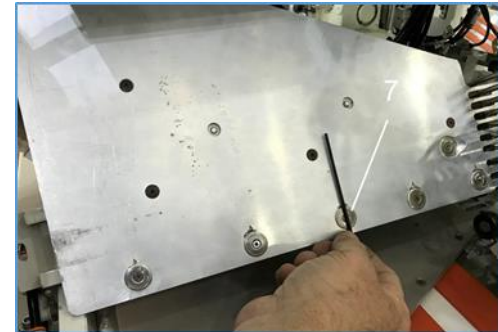

B. Bottom Ply

Its purpose is to maintain sleeve alignment against the guide pins.

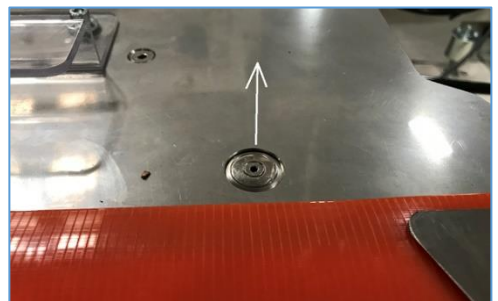

C. Seamer

Its purpose is to help to transport the sleeve under the seamer conveyor.

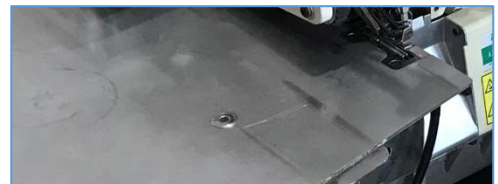

8. Cylinders

A. Hemmer Cylinders

1. Tension release Cylinder

It controls the movement of the hemmer thread release.

2. Foot lift cylinder

It controls the movement of the

3. Puller pressure cylinder

Its controls the pressure of the sewing puller.

4. Sewing head lift cylinder

It is locate under the bottom conveyor table. Its function is to raise the sewing head. It is activated by a pneumatic switch located at the folder clamp

B. Fold in Half Cylinder

5. Clamp plate assembly Cylinders

Its controls the opening and closing of the sleeve clamp

6. Transport 1 Cylinder

Its controls the movement of the sleeve from the sleeve clamp to the Transport 2

7. Transport 1 Clamp Cylinder

Its controls the clamping of the sleeve by the Transport 1

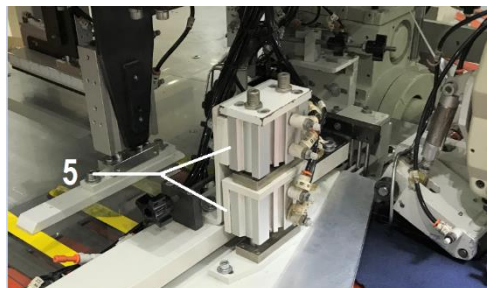
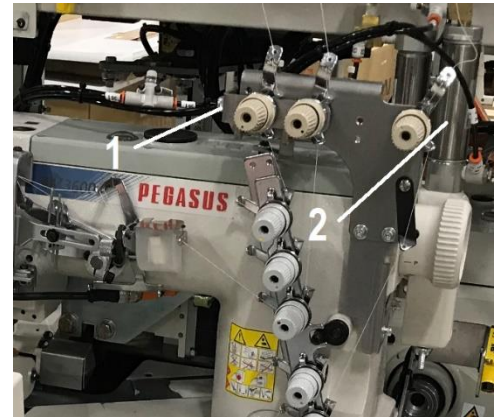

Service Instructions

8. Transport 2 Cylinder

It controls the movement of the sleeve form the Transport 1 to the seamer.

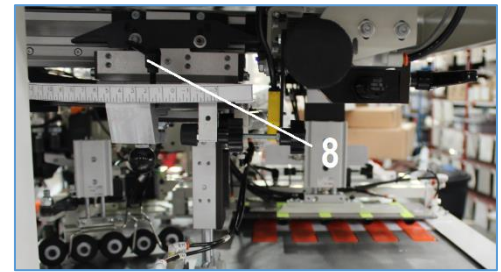

9. Transport 2 Clamp Cylinder

It controls the movement of the clamp cylinder

10. Transport 2 Finger Clamp Cylinder

It controls the movement of the finger clamp

11. Transport 2 Rotate Cylinder

It controls the movement of the Transport 2 clamp rotation

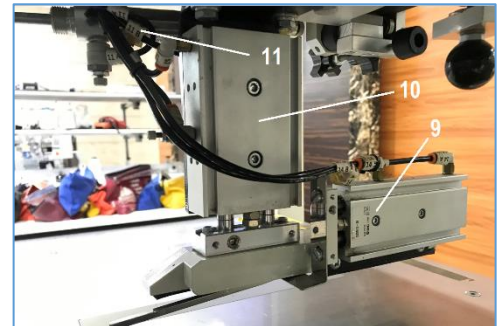

C. Seamer Cylinders.

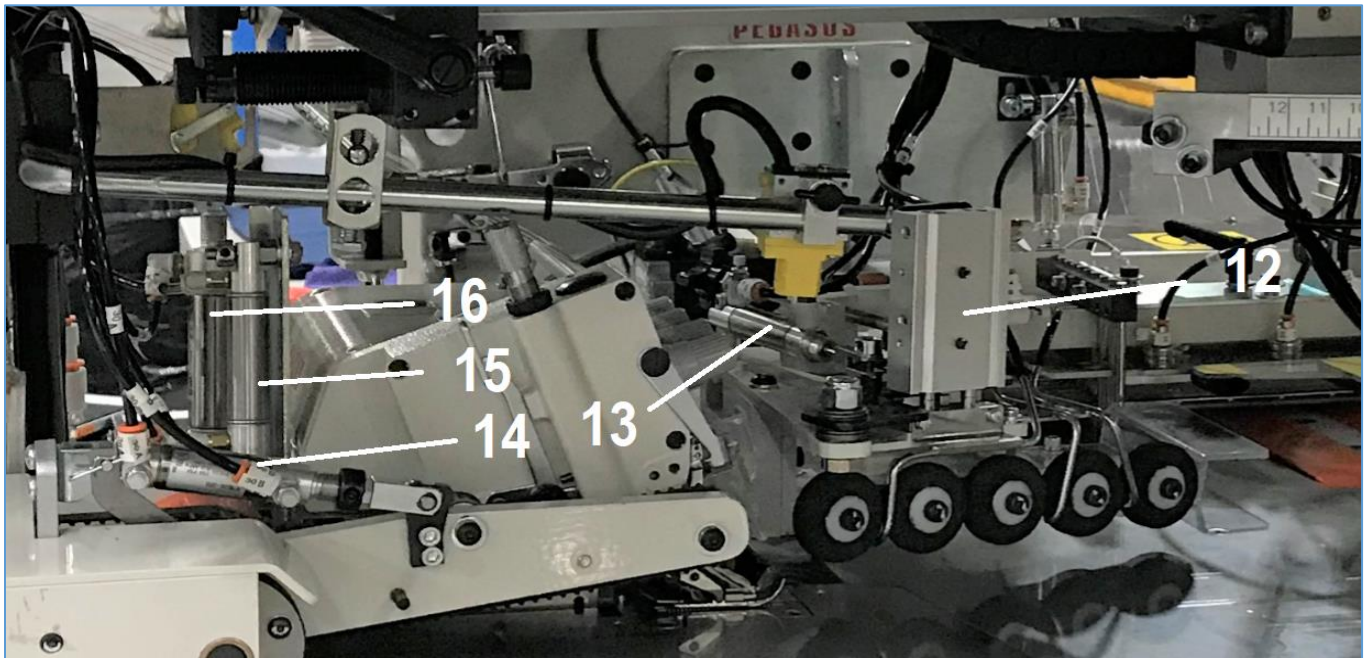

12. Guide Wheel Up / Down

It controls the movement of the guide well up and down

13. Guide Wheels Rotate

It controls the movement of the guide wheel rotation.

14. Seamer Front Conveyor Arm Lift

It controls the movement of the seamer front conveyor arm. The movement speed is controlled by the flow controls mounted on the cylinder.

15. Closer Knife

It controls the cutting of the sewing thread at the end of sewing.

The time of his activations is controlled in the Seamer Advanced Settings [Thread Chopper on time].

16. Foot Lift

It controls the movement of the seamer presser foot

Service Instructions

17. Seamer Thread Tension Opener

It controls the thread tension release at the seam end. It is activated by the Tension opener valve. The time of this activation is controlled in the Seamer Advanced Settings [Tension delay].



D. Stacker Cylinder's

18. Trap Door Cylinder

Transport the already seamed from the seamer conveyor to the stacker conveyor.



19. Stacker Door Cylinder

The Stacker speed is controlled by 2 flow controls connected directly to the air cylinder. The activation time is controlled in the Stacker ADVANCED SETTINGS (Stacker Door On Delay). The movement must be fast enough to remove the part from the conveyor (Use air flow control), but the arm should not reach the maximum extended position. The length of the activation is control by the STACKER ADVANCED SETTINGS (Stacker Door On Time).

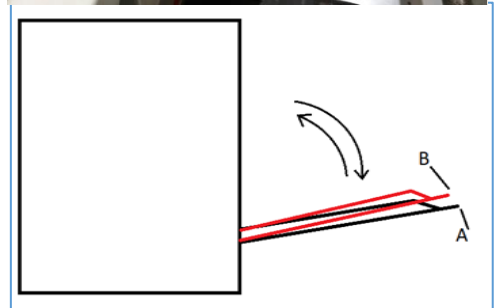

20. Indexer Cylinder

Responsible to move the sleeve bundle out of the stacker door.

21. Unload Cylinder

Responsible to move the already finished bundles to the bundle table



3.4. Electrical

NOTE: All maintenance should be performed by a qualified service technician.

1. Ground

This unit need to be connected to ground (earth) for several reasons. In most powered equipment, exposed metal parts are connected to ground to prevent user contact with dangerous voltage when electrical insulation fails. In electrical power distribution systems, a protective ground conductor is an essential part of the safety Grounding system. Connection to ground also limits the build-up of static electricity



2. Main Circuit Breaker

The main power On/Off switch is on the inside of the control Panel. It is used to turn the power on to the whole machine. This machine requires 220V Single Phase. If you have problems with the power not coming on when the ON button is pressed you may check this switch.

ATTENTION. Make sure that the machine is unplugged before proceeding and that all lock out/tag out procedures have been correctly followed (See to Lockout tag out procedure)



3. Main Power Contactor.

When you press the green button above the touch Screen, it activates the contactor to turn on the power to the machine.

It also functions to protect the unit after a power failure. It will keep the machine without power until the green START button is pressed.



4. Thread Break Detectors.

A. Looper Thread Sensor

This type of thread detector monitors the consistent movement of thread at a 5-degree angle (see picture) over a ceramic surface. With the unit running in manual mode, the LED on the detector must not be on. The presence of a red light on any of the detectors indicates thread breakage or maladjustment, thus causing the unit to stop. Part # 011-132A

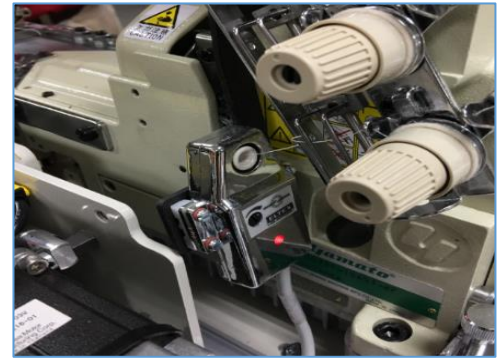

B. Adjustment.

To adjust thread detector, switch control panel to manual. Depress the chain switch to make unit run and chain-off. Take precaution that the chain is under chain puller before running.

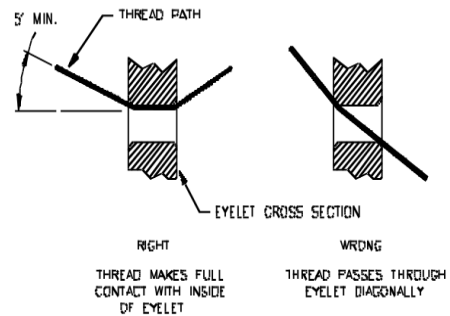

CROSS SECTION OF THREAD EYELET SHOWING RIGHT AND WRONG THREAD PATH.

Looking at the face of the thread detector with unit running in manual chaining mode, turn blue nylon screw (see Fig. 2) counterclockwise until you see the LED light up. Turn screw clockwise until LED goes out. Turn 1/16" more CW.

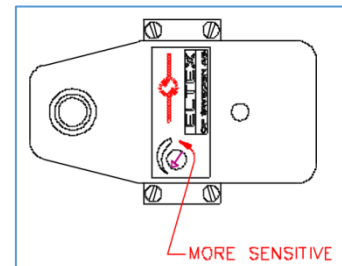

C. Needle Thread Sensor

Part Number: (4003-3WT2)

The needle thread Sensors are optical sensors that detect the vibration frequency of the thread as it is sewing. The tread must pass the sensor at the correct level and frequency to be detected. The tension spring assembly is the only adjustment for the vibration frequency, If is to rigid the thread wont vibrate enough, Use the minimum tension possible to get consistent detection.

The Sensor can be turned off and reset by pressing the RED on the Sensor.



5. Stepping Motors

There are 3 stepping motors in the machine. The Chain Puller and the 2 conveyor belts. The Sewing Head Puller is controlled by the upper stepper box. The Hemmer and Seamer conveyors are controlled by the lower stepper box.

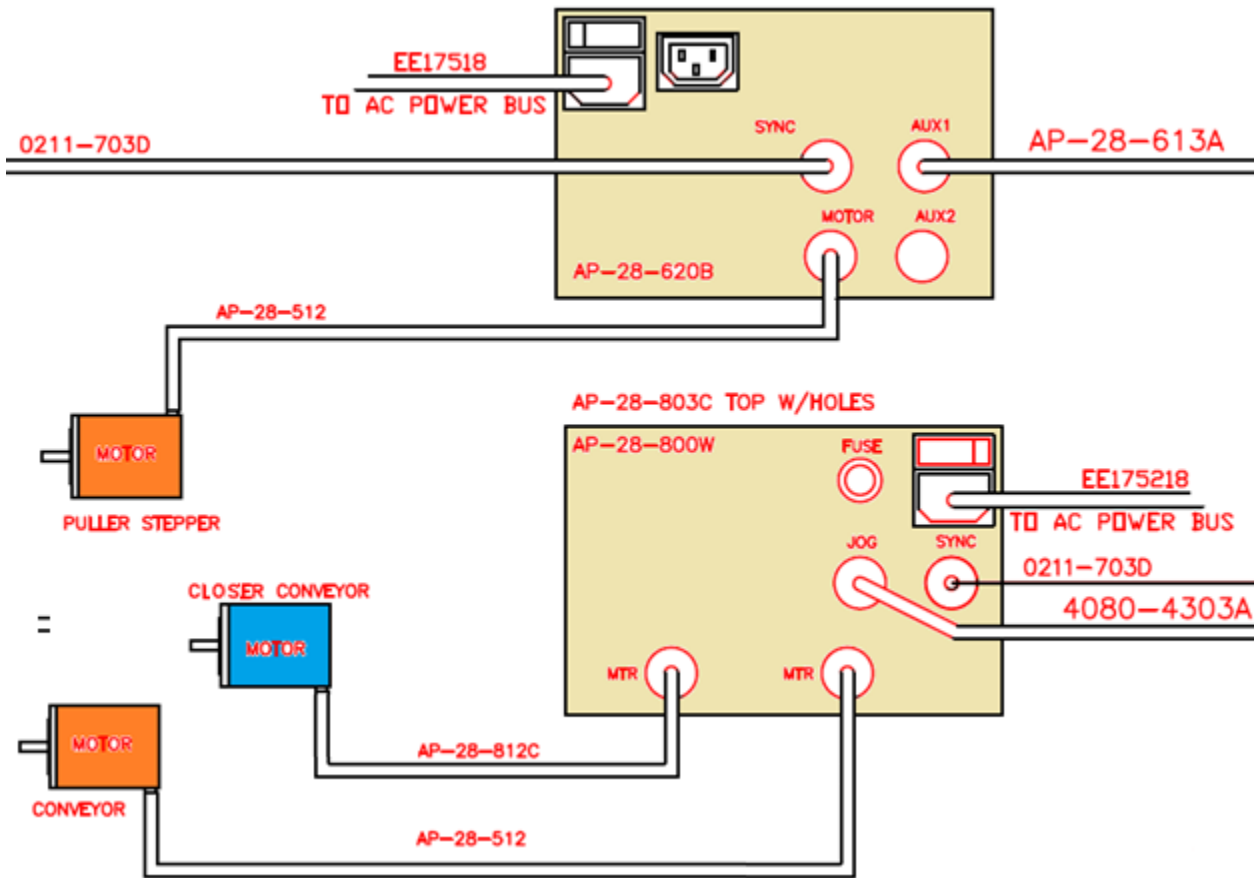

The Chain Puller uses a 2 AMP motor.
The Hemmer Conveyor Belt uses a 4 AMP motor.
The Seamer Conveyor Belt uses a 2 AMP motor.

Service Instructions

A. Hemmer Sewing Head Puller Control Box

Thumbwheels

Left thumbwheels

They adjust the speed of the puller roller when running in CHAIN Speed. This Speed is used before the sleeve gets under the presser foot, and in the gap between sleeves.

- If you change the RPM of the sewing head, there is no need to adjust the thumbwheels; they will remain synchronized to the head.
- Decreasing the number makes the puller go slower.



Right thumbwheels

They adjust the speed of the puller roller when running in SEWING Speed. This Speed is used when the sleeve is under the presser foot.

- If you change the RPM of the sewing head, there is no need to adjust the thumbwheels; they will remain synchronized to the head.
- If you change the sewing stitch length, it will be necessary to adjust these numbers to re-synchronize the puller with the sewing head.
- Decreasing the number makes the belt go slower. For example, if you changed the stitch length from 10 SPI to 11 SPI, you would need to decrease the number in the thumbwheels by 10% to match the 10% shorter stitch length.

Jog Button

Pressing the JOG button will turn on the stepping motor in Jog Speed.



Power

There is an On/Off switch (A) , fuse (B) , JOG cable (C) , stepping motor cable (D) and Sync cable (E) on the back of the boxes

Leave the On/Off switch ON all the time.

NOTE: When working on the box always disconnect the power cord before servicing.

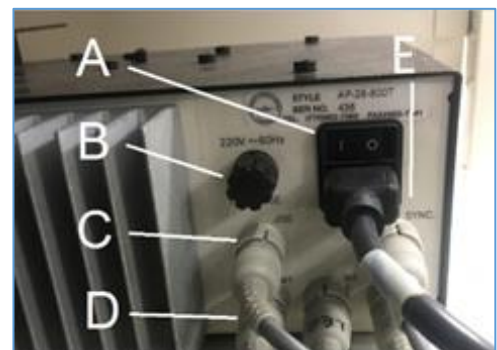

B. Hemmer & Seamer Conveyors Control Box

The control box powers the Hemmer and Seamer conveyor motors. The amber light show that the box is energized.

Thumbwheels

Right Thumbwheels

They control the synchronous speed of the hemmer feed belts while sewing



- If you change the RPM of the sewing head, there is no need to adjust the thumbwheels; they will remain synchronized to the head.
- If you change the sewing stitch length, it will be necessary to adjust these numbers to re-synchronize the feed belt with the sewing head.
- Decreasing the number makes the belt go slower. For example, if you changed the stitch length from 10 SPI to 11 SPI, you would need to decrease the number in the thumbwheels by 10% to match the 10% shorter stitch length.

Hemmer Conveyor Sew speed adjustment

The conveyor belt should feed at the same lineal speed as the sewing head.

Based on the stitch length, calculate the lineal speed. Measuring with a tachometer, run the conveyor on “SEW”: speed and see if it matches the sewing lineal speed. Adjust the 3 digits dial of the conveyor box that control the conveyor speed to match the lineal sewing speed. See example below of the material reaction with different Sew speed values.

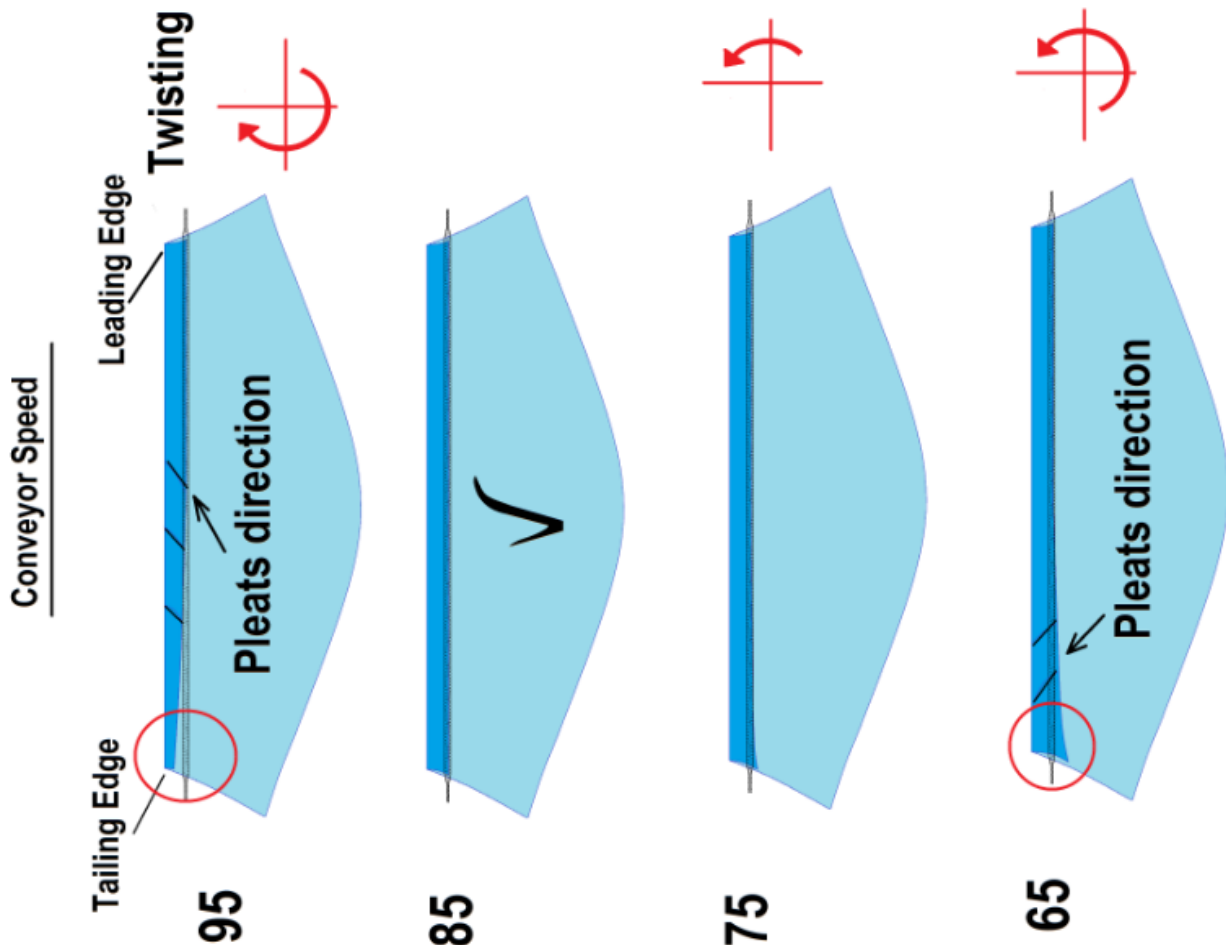

Service Instructions

Left Thumbwheels

The thumbwheel switches labeled SEAMER CONVEYOR SYNC 1 are used to synchronize the conveyor with the Seamer sewing head. They control the synchronous speed of Seamer Conveyor while sewing.

- The number set into the thumbwheels depends on the stitch length of the Seamer and the motor used to drive it. The sleeve should sew straight into the Seamer/conveyor. If the sleeve pulls away from the trimming cutter, the conveyor is running faster than the sewing head and the number should be reduced. If the sleeve is pulled into the trimming cutter, the conveyor is running too slow, and the number should be increased.
- If you change the RPM of the Closer sewing head, there is no need to adjust the thumbwheels; they will remain synchronized to the head.
- If you change the sewing stitch length, it will be necessary to adjust these numbers to re-synchronize the feed belt with the sewing head.
- Decreasing the number makes the belt go slower. For example, if you changed the stitch length from 10 SPI to 11 SPI, you would need to decrease the number in the thumbwheels by 10% to match the 10% shorter stitch length.

Jog Speed Dial

It controls the Jog Speed of the Hemmer belt. This is the speed between sleeves when the hemmer sewing head is not running. This speed must match the synchronous speed of the belt while sewing. Readjust the center dial of the box if required. Moving the tab to the left unlocks the dial. Moving the tab to the right locks the dial.



Jog Button Hemmer

Pressing the right JOG button will turn on the Hemmer belt stepping motor in Jog Speed.



Jog Button Closer.

Pressing the left jog button will run the closer conveyor stepping motor. This is the speed between sleeves when the closer sewing head is not running. This speed is used to help to form the seamer chain and transport the sleeve to the stacker. To adjust the speed the box needs to be opened. Set the Seamer JOG speed with a potentiometer inside the stepper control box. The JOG speed should be adjusted to be about 25% faster than the synchronous speed See

Power

On the back of the boxes, there is a fuse holder and an on/off switch. Leave the switch on, except to do maintenance on the stepper motors or conveyors. Both amber lights must be on during machine operation.

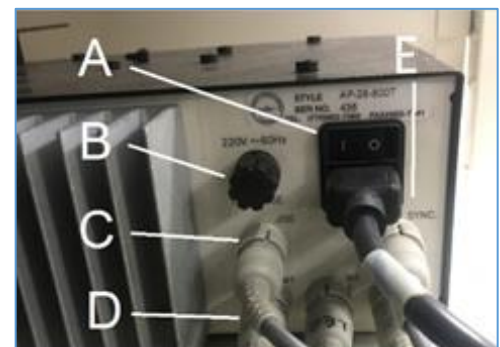

6. Sewing Motor Control Boxes

Units can be supplied with 2 different motor types

A. Efka

It is located under the sewing head. It has an On/Off switch which should remain in the “ON” position at all times, the Sewing head is controlled by this box

Programming the Control Box

NOTE: The parameter numbers in the illustrations below serve as examples and may not be available in all program versions. In this case, the display shows the next higher parameter number. See List of Parameters. If you have a screen with 4 digits your access code will be 3112 instead of 311

Parameter Settings EFKA DC1500

Hemmer

Before Programming, Perform a Master Reset of Parameters (See Below)			
PARAMETER	RANGE	VALUE	DESCRIPTION
290		5	Mode of operation. MUST SET THIS PARAMETER FIRST!
026	0-5	0	F-026=0 to disable the EB401 selection after power on.
111	200-9900 rpm	4800	Maximum speed when "129" is 0, 1, or 2.
119	1-3	1	Linear acceleration
161	0-1	1=CCW	Motor rotation
270	0-5	1	External handwheel sensor configuration.
272	015-9999	1000	Drive ratio between motor pulley and handwheel pulley. If handwheel pulley is smaller than motor pulley, increase this value to slow down sewing head until measured speed matches speed set with parameter 111. (For Yamato and Pegasus, setting should be 1000; for Rimoldi, setting should be 1240)
362	0-1	1	Position sensor voltage: 0 = 5V, 1 = 15V
436		0	Use code "5913". This disables an input that was causing box to reset itself.
401	0	1	Change 401 from 0 to 1 to save all parameters
Front panel LED's:			Programming Instructions:
LED 1:	Off		1. Power on holding down the "P" button till "COD" is displayed.
LED 2:	Off		2. Press ">>" once and enter the number "5913"
LED 3:	Off		3. Press "E" once and "4.0.0." is displayed this is a parameter
LED 4:	Off		4. Proceed to the parameter to be changed and press "E"
LED 5:	Off, Stop at needle down.		5. The value now shows in the screen, adjust to desired value.
LED 6:	On, Stop at needle up.		6. Press "E" to enter value and continue with parameter setting.
LED 7:	Off		7. Repeat for other parameters, press "P" once when complete.
LED 8:	Off		8. Run sewing head to save parameters before powering down
			To Perform Master Reset of Parameters:
			1. Power on holding down the "P" button till "COD" is displayed.
			2. Press ">>" once and enter the number "5913"
			3. Press "E" twice and "093" is displayed.
			4. Press "+" once, "094" is displayed.
			5. Press "P" to exit programming mode with all default values.

Seamer

Before Programming, Perform a Master Reset of Parameters (See Below)			
PARAMETER	RANGE	VALUE	DESCRIPTION
290		5	Mode of operation. MUST SET THIS PARAMETER FIRST!
026	0-5	0	F-026=0 to disable the EB401 selection after power on.
111	200-9900 rpm	6800	Maximum speed when "129" is 0, 1, or 2.
119	1-3	1	Linear acceleration
161	0-1	0=CW	Motor rotation
270	0-5	1	External handwheel sensor configuration.
272	015-9999	1000	Drive ratio between motor pulley and handwheel pulley. If handwheel pulley is smaller than motor pulley, increase this value to slow down sewing head until measured speed matches speed set with parameter 111. (For Yamato and Pegasus, setting should be 1000; for Rimoldi, setting should be 1240)
362	0-1	1	Position sensor voltage: 0 = 5V, 1 = 15V
436		0	Use code "5913". This disables an input that was causing box to reset itself.
401	0	1	Change 401 from 0 to 1 to save all parameters
Front panel LED's:			Programming Instructions:
LED 1:	Off		1. Power on holding down the "P" button till "COD" is displayed.
LED 2:	Off		2. Press ">>" once and enter the number "5913"
LED 3:	Off		3. Press "E" once and "4.0.0." is displayed this is a parameter
LED 4:	Off		4. Proceed to the parameter to be changed and press "E"
LED 5:	Off, Stop at needle down.		5. The value now shows in the screen, adjust to desired value.
LED 6:	On, Stop at needle up.		6. Press "E" to enter value and continue with parameter setting.
LED 7:	Off		7. Repeat for other parameters, press "P" once when complete.
LED 8:	Off		8. Run sewing head to save parameters before powering down
			To Perform Master Reset of Parameters:
			1. Power on holding down the "P" button till "COD" is displayed.
			2. Press ">>" once and enter the number "5913"
			3. Press "E" twice and "093" is displayed.
			4. Press "+" once, "094" is displayed.
			5. Press "P" to exit programming mode with all default values.

B. Panasonic

Programming D9 Motor

1. Turn off power to machine.
2. Hold Up Arrow button, Turn on the power
3. Display shows Axxx
4. Use + & - buttons to scroll to desired parameter #.
5. Press > to toggle to parameter value.
6. Displays shows the parameter value xxxx.
7. Use + & - buttons to change parameter value.
8. Press enter (E) button to save change.
9. Press > to toggle to back to parameter number.
10. Use + & - buttons to scroll to next desired parameter #.
11. Repeat until all desired parameters are updated. Be sure to press enter (E) after changing the parameter values.
12. Turn off the power momentarily.
13. For 411 set the following parameters:
 - A 27 = 1 (Stop needle up)
 - A 29 = 1 (Rotation, 1 CCW, 0 CW)
 - A 70 = 5000 (max speed)
 - A 91 = 1 (Pneumatic solenoid foot lift, 100% modulation)
1. Turn off power to machine.
2. Hold "E" & "-" buttons, Turn on the power
3. Use + & - buttons to change parameter value to F166.
4. Press > to toggle to parameter value.
5. Use + & - buttons to change parameter value to 600 (one minute foot time-out).
6. Press enter (E) button to save change.
7. Turn off the power momentarily.



Programming D7 Motor

Apply to Small Programmer MPUR01A10

NOTE: to adjust parameters after initial programming, start with step number 10

1. Turn off power to machine.
2. Plug in the small Panasonic programmer.
3. Hold ENTER and MODE "+", Turn on the power. Continue holding down buttons for 8 seconds, until 106 Y2 is displayed on screen.
4. Double-click the "ENTER" button to exit parameter mode.
5. Turn off the power.
6. Turn the speed control on the motor to the minimum.
7. Turn on the power.
8. Run the sewing head for a few seconds (at least 5) to set the pulley ratio in the Panasonic Motor. Pressing the sew pedal will cause the head to sew.
9. Turn off the power.
10. Turn on the power.
11. Press MODE "+" several times until the word parameter is displayed on the screen.
12. Double-click the "ENTER" button to enter parameter mode.
13. Using the MODE "+" and "-" buttons to locate the parameter and the DATA "+" and "-" buttons to adjust the individual parameter, set the following parameters:
 - 135 = desired RPM
 - 605 = 64 (foot modulation On-time)
 - 606 = 1 (foot modulation Off-time)
14. (Refer to this step only for Pegasus Machines with a hall effect under trimmer sensor) Set parameter 011 equal to 131. (011=3 is default)
15. (Refer to this step only for Rimoldi Machines with a hall effect position sensor) Set parameter 520 equal to 1 and parameter 523 equal to 222.
16. Double-click the "ENTER" button to exit parameter mode.
17. Turn off the power.
18. Turn the speed control on the motor to the maximum.
19. Turn on the power.
20. Test RPM of sewing head with tachometer.
21. The sewing speed shouldn't exceed the setting in parameter 135

Start delay from lifted foot is parameter 603 and is typically set at the factory default. *

Reset sequence for large programmer:

Hold the "A", "B" and "ENTER" buttons, while turning on the power, wait 5 sec.

Press the enter button.

Parameter programming sequence for large programmer:

Hold the "D" and "ENTER" buttons, while turning on the power, wait 5 sec.

Press the enter button.

Press the backtick buttons (the two buttons on the bottom right of the programmer)

Use the "A" and "B" buttons to locate the parameter (see step 13 above) and "C" and "D" to adjust the individual parameter (see step 13 above)

7. Electric Eyes

The unit uses several eyes and sensors to control the Operation Sequence.

A. Eye Sensor Adjustment

Remove the clear plastic cover from the end of the sensor. There are two adjusting screws under the cover. One is labeled "GAIN" and is used to set the sensitivity of the sensor. The other screw is labeled "DO & LO" and should always be fully clockwise. LO/DO is for light or dark operated. All eyes are set to LO light operated.

With the end of the sensor pointing at the center of the reflective tape, turn the "GAIN" screw counterclockwise until the red Led indicator is off

Turn the "GAIN" screw clockwise until the LED indicator comes on.

Turn the "GAIN" screw one full turn clockwise. The LED indicator should be blinking slowly approximately 2 pulses per second. The eye on the hand wheel should be at least 2 full turns.

Cover the eye so that the sensor cannot see the reflective tape and the Led should go off.

Part #FFSM312V

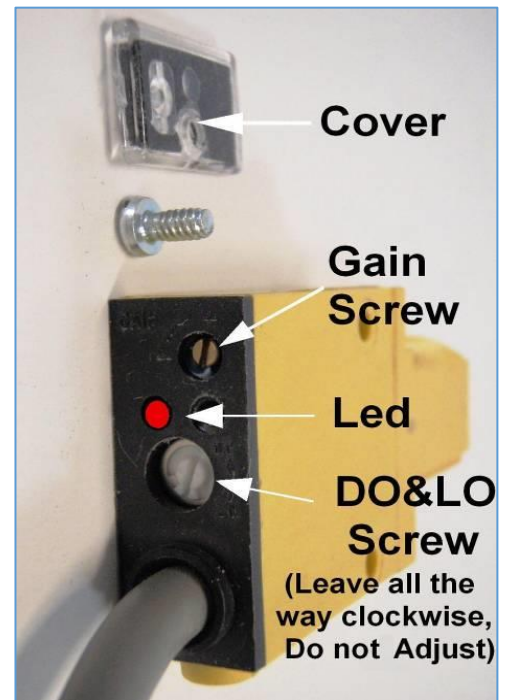

B. Reflective Tape Maintenance

Use a soft cloth for cleaning. Do not use chemicals or abrasives to clean it. Avoid any contact with oils and liquids. Do not touch the tape with bare fingers. If tape is dirty or opaque, the eye may not function correctly.



Service Instructions

C. Eyes Functions

The unit uses 10 eyes to be able to operate all the functions. The eyes work as follows:

1. Hem Fold Eye

After the unit starts in the auto mode, this sensor reads the leading edge and keep the conveyor running. If there is no fabric under the folder eye, a timer will time out (Conveyor Stop Delay #15) and the unit stops. It also controls the timing of the folder air.

2. Hemmer Sew Eye

Located in front of the presser foot, the function of the eye is to read the leading and trailing edges of the sleeve and start several of the time counters.

This eye controls the start of the hemmer, timing of the presser foot up and down, puller, sew and chain speed, cutting and vacuum.

3. Fold in half Eye

When the leading edge covers the Fold In Half eye, it starts the counting for the fold in half cycle. (#23)

After time is counted, it opens the gap between the fold in half plates to its maximum, starts the hem jets, the body jets and the air alignment jets to pull and align the sleeve into the clamp.

It starts an additional counter (#21) and the Fold in Half plate moves to its middle position to increase the flow to make sure the sleeve comes through flat before it is clamped.

#22 controls how far the sleeve goes into the clamp before the sleeve is clamped. The sleeve should be clamped between the third and the second to last slot in the clamp. The conveyor keeps running.

The FIH eye reads the trailing edge of the sleeve and starts the counter (#25) Fold Transport Clamp down delay. When the time is counted, the Transport 1 clamp moves down and clamps the sleeve. It controls the alignment of the sleeve at the closing edge.

- Time too short, material will be short of matching.

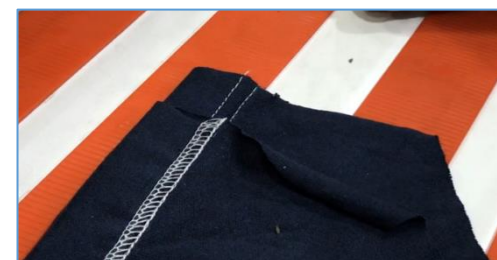

Service Instructions

- Time too long, there will be extra top material overlapping the top material.



Fold Air On delay # 24

This controls the air coming from the lower plate that the material wrap around, to inflate the sleeve so that the ply does not drag across each other and affect the alignment.

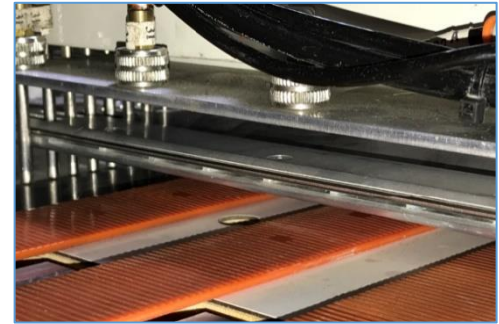

If number #23 is too small, the vacuum it will try to pick it up too early and the friction across the edge will not allow the sleeve into the clamp cleanly.

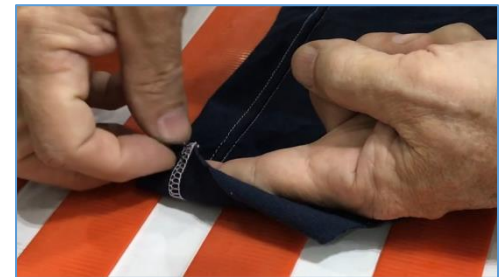

If #23 is too large, the leading edge will pass too far, and after the vacuum turns on, the vacuum will not pick it up, or will leave a fold on the leading edge.



4. Transport #1 Stop Eye

It reads the folded edge after the Transport #1 transfers the sleeve to the eye and stops. After that, transport #2 come and pick the sleeve to the Seamer station,

This eye can be disabled on the Fold In Half Advanced Settings page (Fold Mode Size to "Auto").



5. Seamer Start Eye

After the eye is covered, a timer starts, and the Guide Wheels come down, and the vacuum for the back latch turns on.

The seamer Sewing Head starts sewing.

You can set up a delay on the Pivot to change the profile of the seam using the Seam Guide Straight delay #41

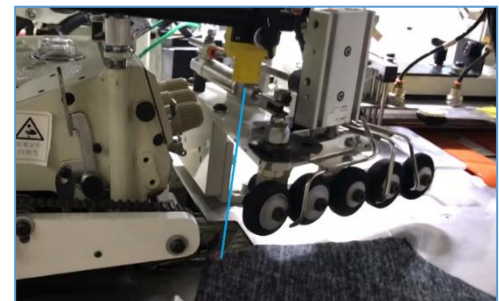

Service Instructions

6. Start Stack Eye

The function of the Stacker Start Eye is to detect the leading edge and activate the Trap Door and Transfer Wheels. The closed sleeve is moved from the seamer conveyor to the stacker conveyor.



7. Stacker Door Eye

The function of Stacker Door Eye is to detect the trailing edge of the sleeve and activate the stacker door.

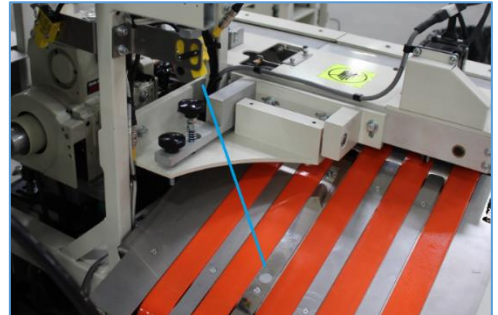

8. Stacker Full eye

When this eye is covered, it will turn on the LED at the hemmer conveyor area telling the operator that the stacker is full, and the unloader needs to be used to move the bundles onto the bundle table to clear the stacker tray.



9. Hemmer Needle Positioning Eye.

The function of the needle positioning eye is to control the position of the needle stop and monitor the motor speed of the hemmer.



10. Seamer Needle Positioning Eye

The function of the needle positioning eye is to control the position of the needle stop and monitor the motor speed of the seamer.



Service Instructions

8. Operation Sequence.

This unit uses several Electric Eyes, Switches and Proximity Sensors to control the Sequence of Operation. After the detection of a signal the Software starts a routine. This routine can include activation of a movement, start a time count, etc. See below the Routines that will be run after the activation of the Sensors and the timer's # on the Advance Set-Up screens.

A. Hemmer

Load sleeve on conveyor Depress Start or Hemmer Start Pedal	Hemmer Conveyor ON	Waste System: ON	Hemmer Trim: ON	FIH Bott. Alignment: ON	FIH LE Clamp MIDDLE
Waiting for Folder Eye to see Leading Edge of Sleeves	Hem. Conv. Jog Off DELAY #3 Hemmer Conveyor: OFF	Waste System: OFF	Hemmer Trim: OFF	Leading Edge Jets: ON Leading Edge Jets: ON Time Leading Edge Jets: OFF	
Waiting for Hemmer Eye to see Leading Edge of Sleeves	Hemmer Head: STARTS #8,8,10	Puller Sew Speed DELAY #6 Puller SEW SPEED	Foot Down DELAY #4 Foot DOWN	LE Chain Cut DELAY #11 Chain Cut CYCLE	Chain Vacuum CYCLE
Waiting for Hemmer Eye to see Trailing Edge of Sleeve	Hemmer Head Off DELAY #16 Head STOP	Puller Fast DELAY #7 Puller CHAIN SPEED	Foot Up DELAY #5 Foot UP	Trailing Edge Cut DELAY #12 Chain Cut CYCLE	

Service Instructions

B. Fold in Half

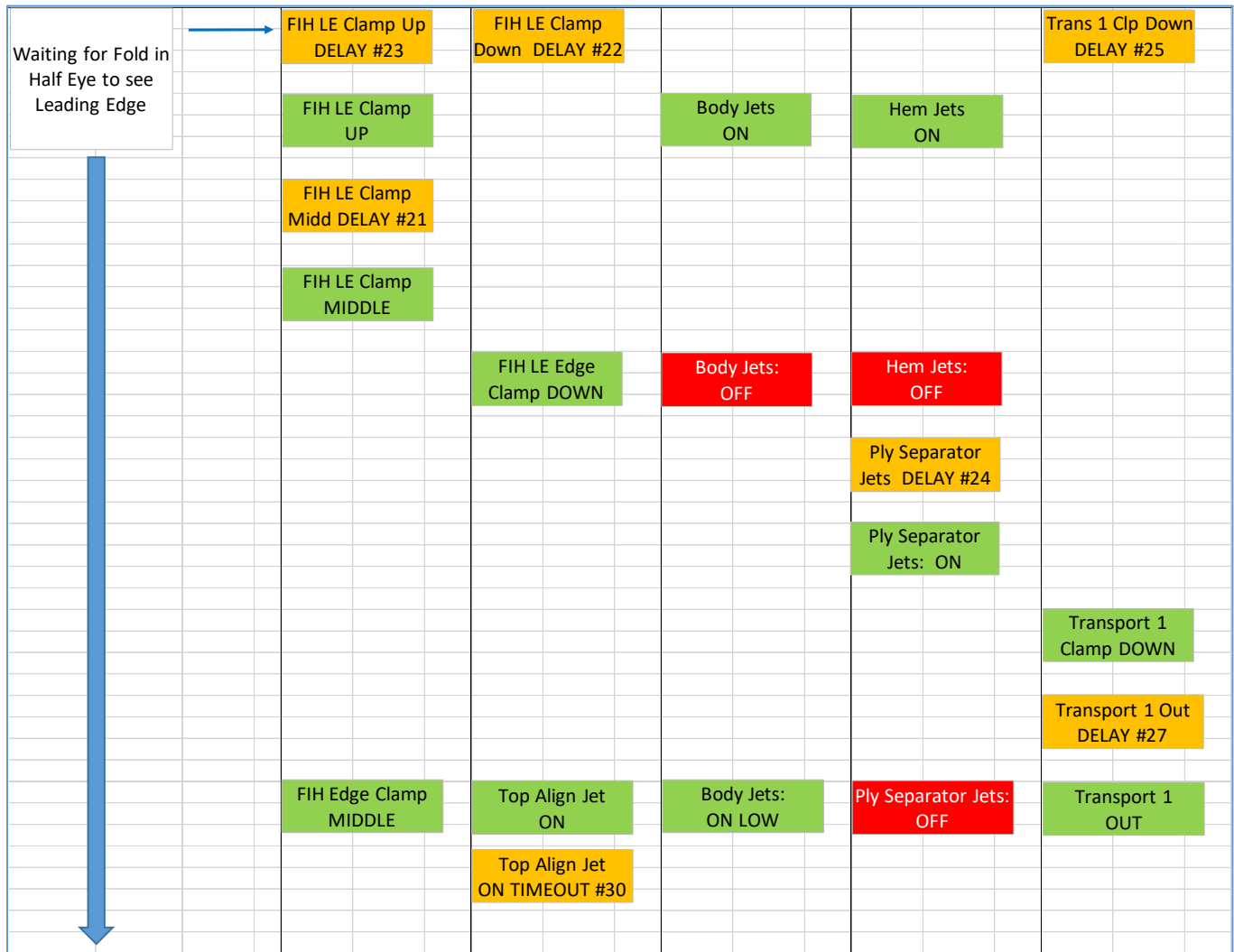

C. Transport

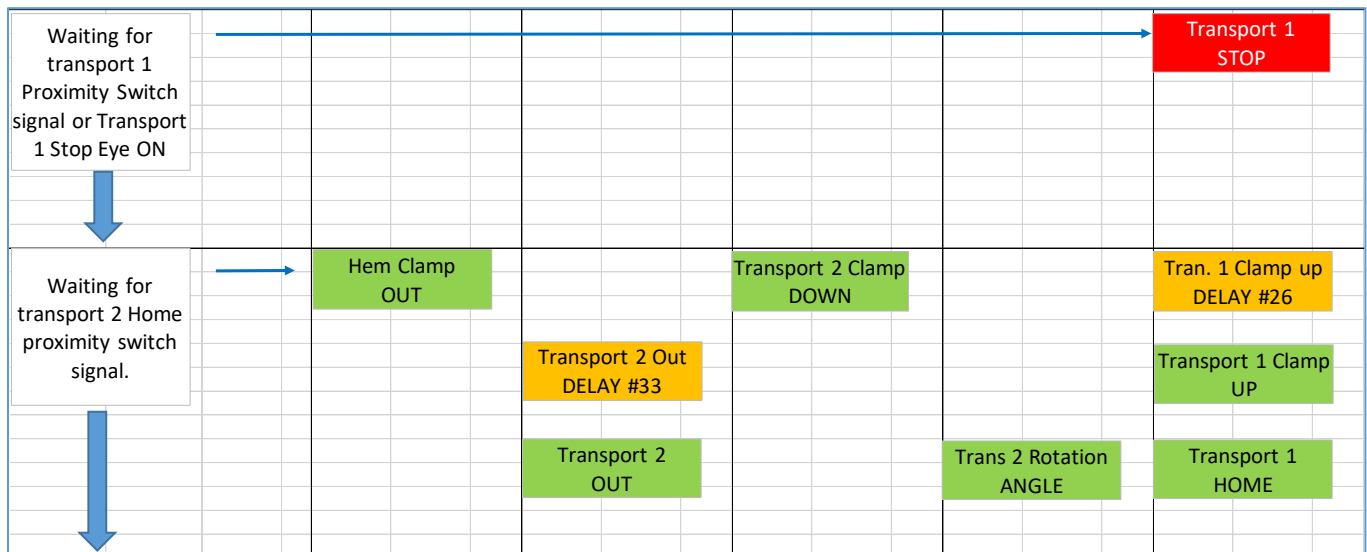

Service Instructions

D. Seamer

Waiting for transport 2 out proximity Switch signal Sew Eyes to see Hem of Sleeve 	Hem Clam HOME Seamer Head RUN Straight Sew TIME (Contr.) #45 Seamer Head STOP (Contr.) Seamer Start DELAY (Contr.) #44 Seamer Head START (Contr.)	Conveyor Arm DOWN Back Latch CYCLE	Trans 2 Clamp Up DELAY #34 Transport 2 Clamp UP Transport 2 Home DELAY #35 Transport 2 HOME	Seam Guide DOWN (Straight) Transport 2 Rot. STRAIGHT Seamer Guide DOWN (Contr.) Seamer Guide Rot. DELAY (Contr.) #41 Seamer Guide STRAIGHT	Stacker Conveyor ON Stacker Conveyor off DELAY #66	
	Waiting for Seamer Eye to see Trailing Edge of sleeve 	Seamer Head STOP	Seamer Conveyor JOG Back Latch CYCLE	Waist System CYCLE Chain Cut DOWN Chain Cut DOWN TIME #49 Chain Cut UP	Thread Untension DELAY #48 Thread Tension UNTENSION (F) Seam Chaining TIME #46 Seam Chain Stretch TIME #47 Thread Tension TENSION (T)	Seam Guide UP Seam Guide ANGLE Conveyor Arm Up TIME #43 Conveyor Arm UP

Service Instructions

E. Stacker

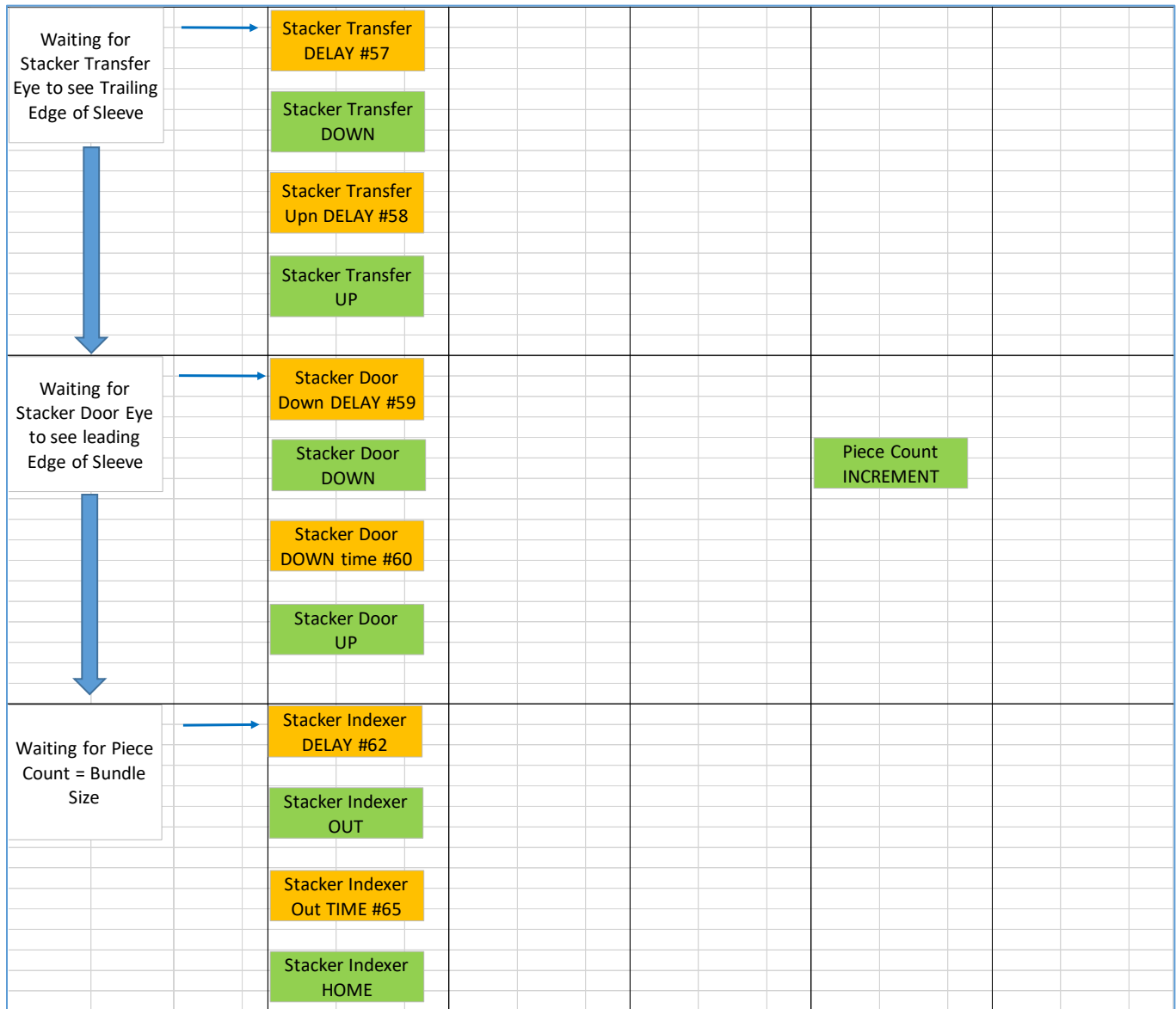

Service Instructions

3.5. Serial Bus

The Serial Bus System, based on only four wires, is self-diagnostic and offers helpful solutions to solve the problem. An operator using a touch screen control panel manages this rugged, uncomplicated system. Designed to international standards, this multi-lingual, easy to operate interface will allow parameters to be saved, allow technician access with password protection, and offers a built-in production performance monitor which can be networked to a central computer.

A warranty of 3-Year covers all electrical components of the state-of-the-art Serial Bus Control. Controller part number is 4080-004.

The functions of the touchscreen are divided into two categories: Operator accessible functions and advanced accessible functions. The advanced accessible functions have five levels of security: Supervisor, Mechanic, Head mechanic, Technician, Engineer



1. Technical Data

SPECIFICATIONS /ESPECIFICACIONES	
input Voltage / Voltage de Entrada	110-240 VAC 50/60 Hz
Input Current / Corriente de entrada	1.4A 50/60 Hz
Output Voltage / Voltage de Salida	+24V DC
Output Current / Corriente de Salida	4.0A

2. Serial Bus Identification Label

Identification is located on back of the Console
Its contents are the Console Style (Example: 4080-003) and the serial number (Example SER NO. 125)

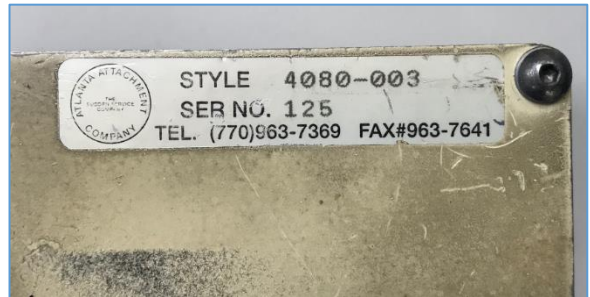

3. Models

Serial Bus System started in 1998. Different Models has been created over the last 20 years. Some updates kits are available to update from old systems to the new larger screen version.



4080-000

4080-001

4080 003

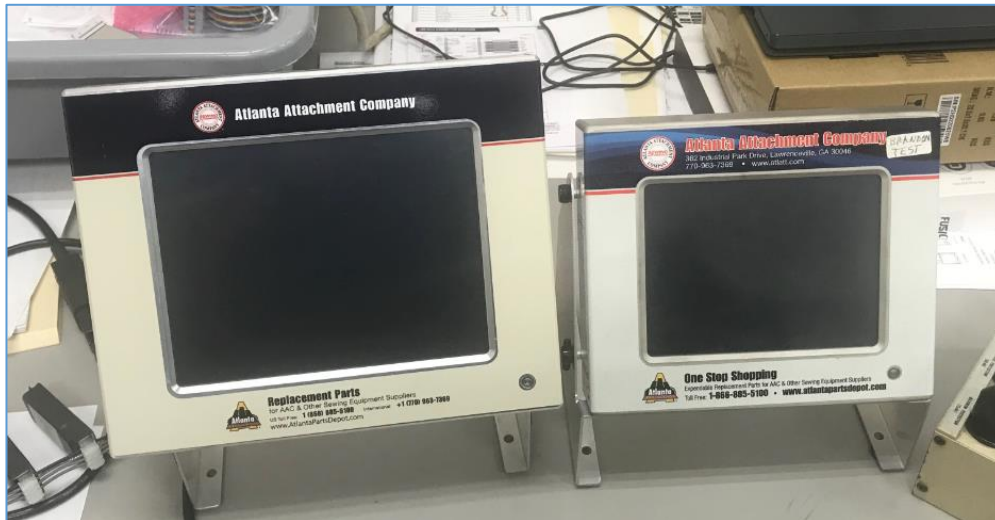

4080 -
004A
4080
004

4. Concept Wiring

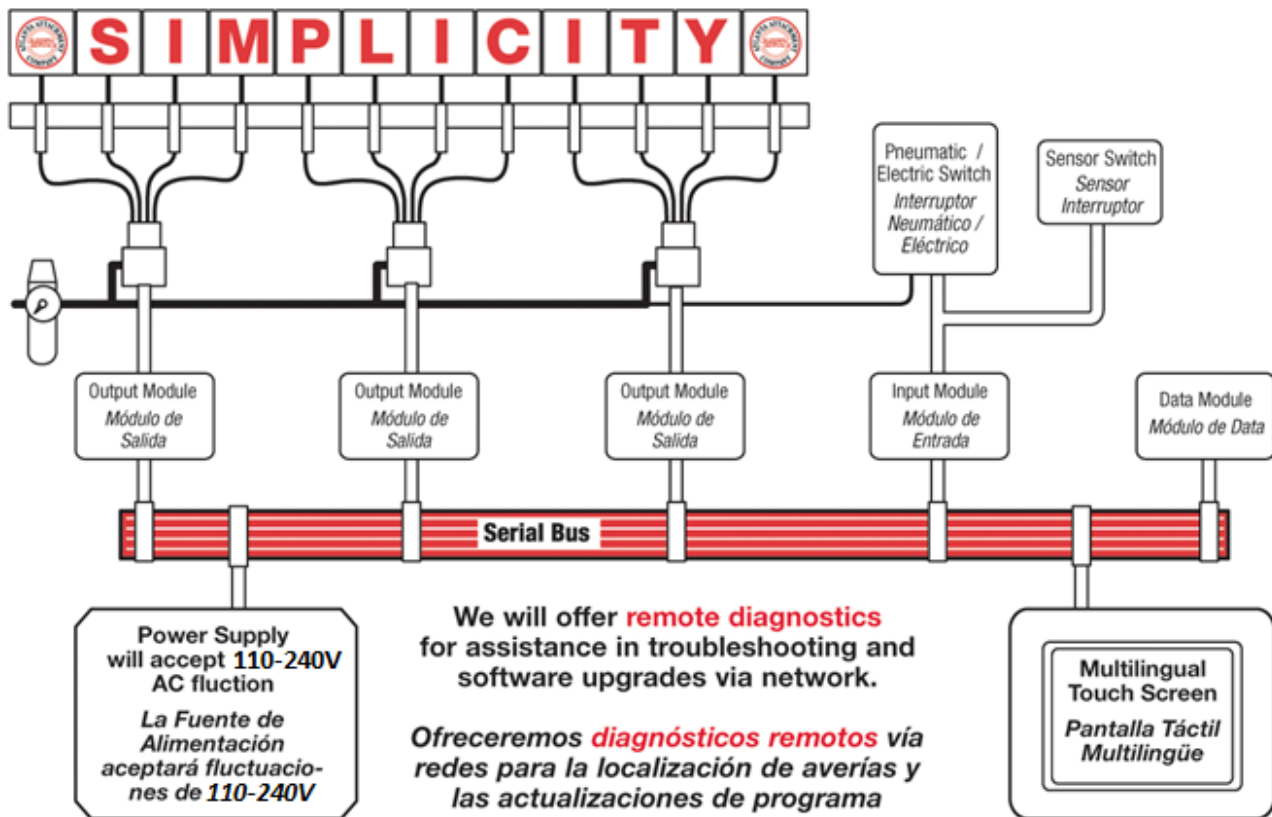

5. Parts and Components

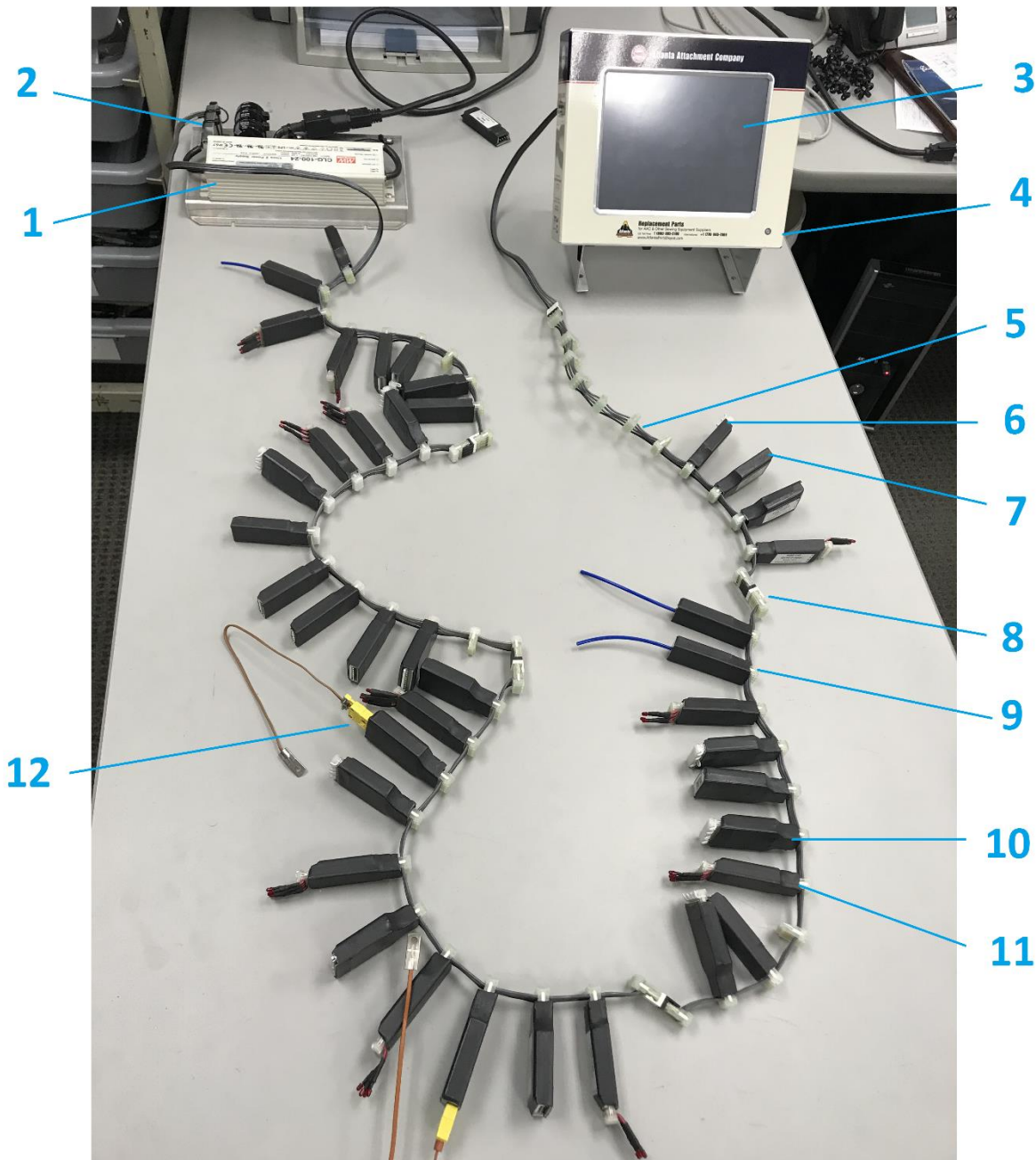

1.- Power Supply	5.- Cable (4 wires)	9.- Air Module
2.- Power Module	6.- Data Module	10.- Input Module
3.- Touch Screen	7.- Program module	11.- Output Module
4.- Tri-Color LED	8.- Wire extension connector	12.- Temperature Module

Service Instructions

6. Power Supply

Earlier systems were provided with the 4080-990 Power Supply. It provide 24VDC to the whole system



Later Systems use the 4080-990B power Supply. It provide 24VDC to the whole system

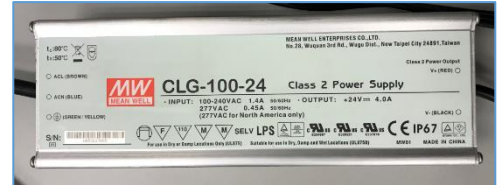

7. Wire Cable

Used to interconnect whole the system. 2 lines are powered and the other 2 are used to transfer data from the touch screen to the module and from the modules to the touch screen.

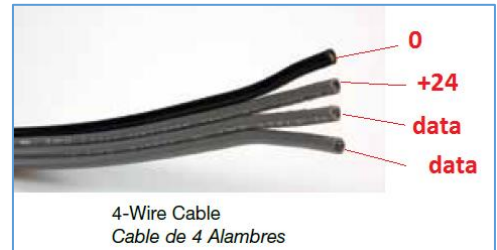

A. Cable Connection

It is important to have a good contact between all wires and module inputs and outputs.

Two special wire insertion tools are used to insert the main 4 wire cable and the small cables into their connectors.

The EEMRT156F is used to grip the main big 4 wires cable to its connectors.

The EEMRT100 is use to connect the smaller output wires to their connectors



The MMIT156 is a little more complex and used to insert the main bigger 4 wires cable to its connectors.

The MMIT-100F is used to insert the smaller output wires to their connectors



Service Instructions

FF156T1804: Conn Idc, 1x4x.156, #18 Awg Thru

FFSC15604: Cover, Strain Relief

001005: Cable, 4 Cond, 18 Awg, Sbus Ribbon, Pvc

001006: Cable, 5 Cond, 18 Awg, Sbus Ribbon, Pvc

EEMRT156F: Tool, Mascon, Conn T-Grip, .156

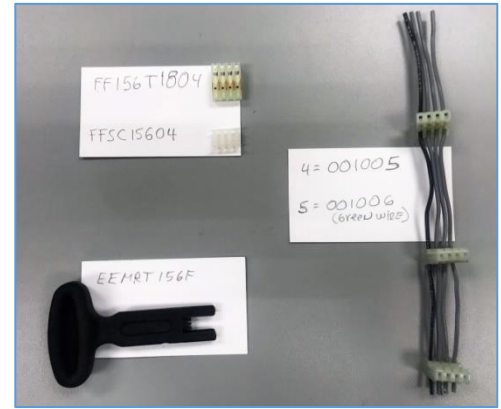

MMIT-100F: Tool, Crimping, ITW 100 Series Connectors

FF100F2203: Conn Idc, 1x3, .100 #22 Awg, End, Red

FFSC10003: Strain Rel, Conn, 100, 3

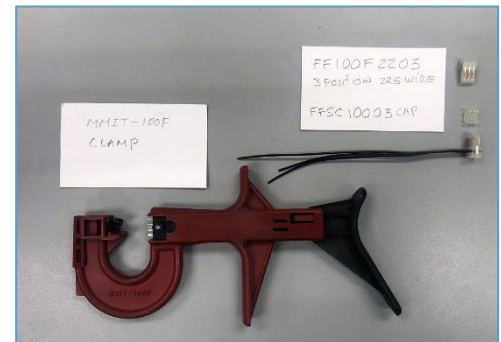

8. Connections Ports

NET: Connect the network connector. To external customer network. Use to industry 4.0

USB 1: No function at this time. USB A type port

USB 2: No function at this time. USB A type port

COM: Connect standard type B USB printer cable. Use to interchange data between computer and the control panel. Example updating software



1.- 16 port auxiliary connector not used at this time.

2.- 7 port for the connection of the 4-wire cable



9. Color LED

The bi or tri color LED is an independent status indicator that works even if the controller's display is not working correctly

A. Bi color LED

The Bi-color LED (A) is used on the 4080-003 and earlier controllers.

General Meanings

OFF : No power

FLASH GRN: OK. All is well and the application software is running.

RED: Program is not running.

RED flash: Software Booting

The software is initializing hardware and running memory checks.



B. The tri-color LED

The tri-color LED (B) is used on the 4080-004 and 4080-004A controllers.

General Meanings

In any color sequence, bright red, yellow, or green indicates the following general meanings:

GRN: OK. All is well and the application software is running.

YEL: Wait. The operating system is doing checks and resolving issues before launching the application.

RED: Fatal Error. The only option is to power down and fix the problem indicated.

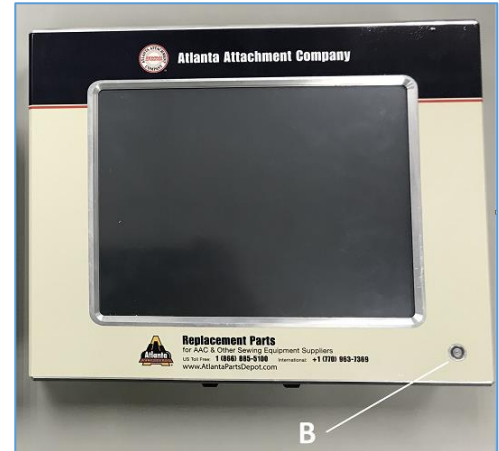

Normal Operation

OFF : No power

The only time the LED should be off is if there is no power. The LED is always a power indicator. Even when the software crashes or locks up, if the -004 hardware is not broken, the LED should still be lit.

RED LO : Software not controlling LED yet

RED LO is normal for a few seconds after a hard reset / power up. Extended RED LO indicates software is not executing due to hardware failure or software that is so badly corrupted that it cannot auto-recover. If the issue is bad software, the only remedy is a USB download.

YEL HI/LO flash: Software Booting

The software is initializing hardware and running memory checks. This may take 6 or 7 seconds.

GRN HI/LOW 1 second "heart beat" : Machine software running

The green heartbeat shows that the application software is executing normally.

In addition, this LED is used to indicate low level faults by blinking a sequence of colors. This information can be used with AAC technical support to troubleshoot issues.

10. Touch Screen

CAUTION: Do Not Use Any Sharp Objects to Touch the Screen.

A. Calibration

If you are having troubles locating the right place to get access to the function by touching the screen a screen calibration may be required.

Proceed as following:

Place one finger on the screen and hold it there while pushing the Green ON button.

1. When the screen turns light, remove your finger and the screen will display two lines, one vertical and one horizontal, intersecting at the top left corner. The text "Touch at the crossed lines to calibrate display." should appear in various languages. In older machines, there will be no text. Using a small pointing device that will not puncture or damage the screen (such as a pencil eraser), touch the screen where the two lines intersect. Do this with as much accuracy as possible.
2. When the screen is touched, the display will change to two lines intersecting at the lower right of the screen.

CUTION: The implementation of step 2 and step 3 directly affects the validity of all the buttons in the entire program. It is very important to be accurate.

3. . Repeat step 2 where these lines intersect. On 004 screen all 4 corners need to be adjusted.

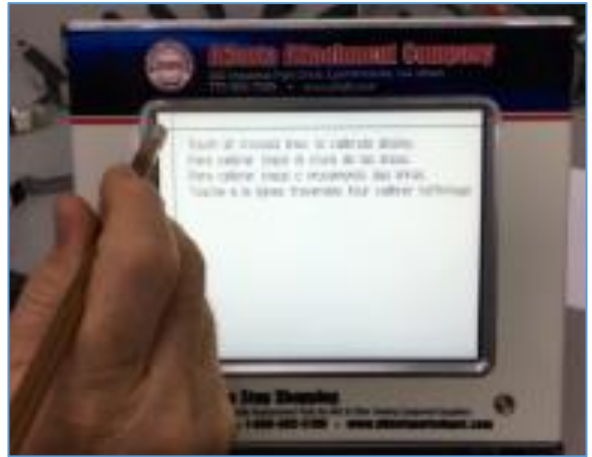

Service Instructions

4. Press the language button of your choice.



5. Press the RESET button at the lower left corner of the screen. See figure.



Service Instructions

B. Calibrating 003 and older Touch Screen

If you are having troubles locating the right place to get access to the function by touching the screen a screen calibration may be required.

Proceed as following:

1. Place one finger on the screen and hold it there while pushing the Green ON button.
2. When the screen turns light, remove your finger and the screen will display two lines, one vertical and one horizontal, intersecting at the top left corner. The text "Touch at the crossed lines to calibrate display." should appear in various languages. In older machines, there will be no text.
3. Using a small pointing device that will not puncture or damage the screen (such as a pencil eraser), touch the screen where the two lines intersect. Do this with as much accuracy as possible.

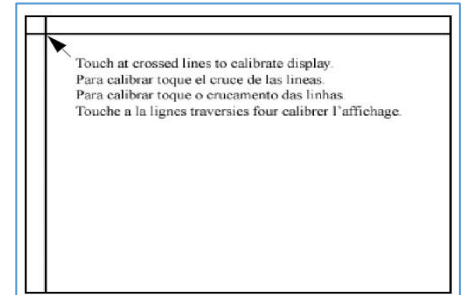

4. When the screen is touched, the display will change to two lines intersecting at the lower right of the screen.
5. Repeat step 4 where these lines intersect.

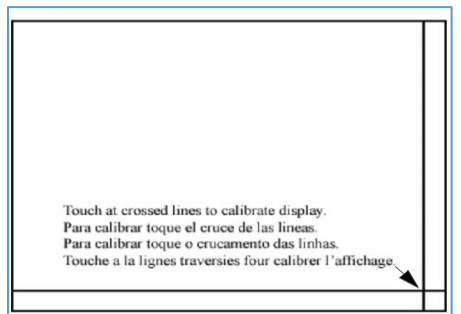

NOTE: The implementation of step 3 and step 4 directly affects the validity of all the buttons in the entire program. It is very important to be accurate.

Press the language button of your choice.

Press the RESET button at the lower left corner of the screen.



C. Installation

To install new screen you must follow these directions.

1. Install new screen and turn power on.
2. When screen displays "Fatal Error Message" press continue.
3. Enter Mechanic Security Code.
4. After reading the "Warning Message" press continue again.
5. Screen will begin to process the up-loading of the existing program from the program module. This will take 60 - 90 seconds.
6. After reading the "Last Warning Message" press continue again.
7. Screen will begin to process information again for 15 - 30 seconds.
8. Reset routine will follow.

NOTE Machine assemblies will reset or move to home positions.

9. Screen will return to the Main Display and is ready to run.

11. Modules

A. Program Module...4080-150

Stores the program information. It is also used to load program modifications or updates. For update procedures please refer to next chapter.



B. Data Module...4080-930

Stores the unique data required to operate this particular machine; such as serial number, original factory parameters, etc. This module should never be exchanged with another machine.



C. Output Module...4080-140

They are responsible for transferring signals from the computer to the working elements such as valves, motors and relays, etc. They have 4 outputs channels.



D. Quad Opto Input Module...4080-120

They are responsible for transferring signals from the machine to the computer, such as external relays. They are optically insulated. They have 4 input channels



E. Input Module...4080-110

They are responsible for transferring signals from the machine to the computer such as switches, electric eyes, sensors, etc. They have 4 input channels



F. Single Output Module ...4080-160

They are responsible for transferring signals from the computer to external single channel device (electrically insulated), usually high load motors.



G. Output Module ...4080-130

They are responsible for transferring signals from the computer to external connections, servo motor controls (electrically insulated) They have 4 outputs channels.



12. Module Replacement

NOTE: Even though all output and/or input modules within the machine are identical, they cannot be moved to another location on the serial bus cable, as the computer automatically assigns a working address for each one.

- If a replacement is necessary, always replace with a new or loaner module from another machine.
- Electrical Power to the machine must be turned “OFF” during replacements.
- Computer will show an error if one or more modules are missing.
- Removing more than 1 module at a time will require reinstalling all of the modules.



A. Replacement of a Single Module

1. Remove the old module and connect the new one. After turning on the power, the computer will show a missing module error.
2. Press Continue and the new module will be addressed, and all modules installed message will be appear
3. Press Reset and the home page will appear

B. Replacement of Memory Modules

NOTE: Make sure that all the settings and save styles are on file. (You will lose all setting and sizes)

During the process you need help from AAC. (Only do this procedure during AAC business hours)

Locate the Memory Module. (4080-970)

- Replace the old module with the new one.



Service Instructions

- Unplug all modules except Program (4080-150), memory (4080-970) and just in the old 004 system the Adaptor module (4080-980).



- Power up the machine.

Fatal error will appear

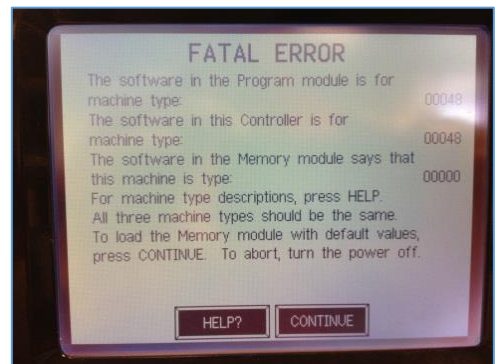

- Press continue.

- To get an engineer code call AAC. (Press on top of screen to get number for AAC)



Service Instructions

- After typing in the engineer code there will be a Warning screen.
- Presses continue at the Fatal Error screen.
- Follow the procedure on the screen until all modules are installed.

NOTE: Press "INSTALL" the first time without installing any modules! The unit should prompt the error message "No Modules installed, or No Modules found". After clearing error message proceed as prompted on screen.

- When all modules are installed, reset machine.
- To clear the 911 error code you need to call AAC
 - Power down the machine
 - Power up the machine while pressing the screen in the middle
 - Let go of the screen when the screen lights up.

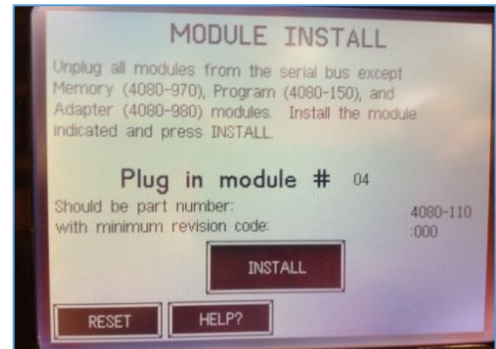
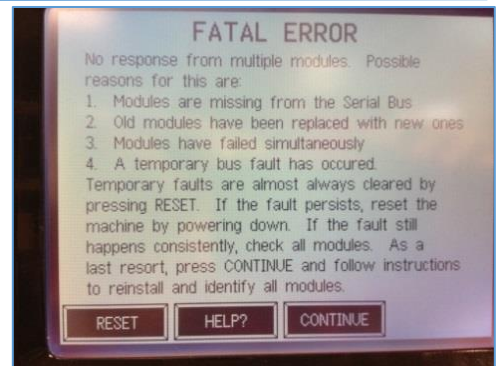

Service Instructions

- Follow the calibration procedure.
- Choose Language
- Press button “MEM MOD CLOCK”.

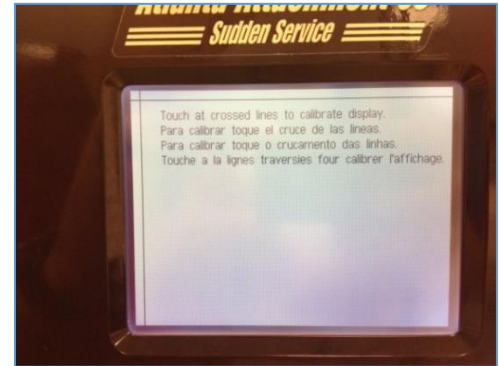

- Use you pass code (Default 22222)
- Have the machine type, serial # and security # ready for AAC (Pic. 6)
- Press button “SET EXP COUNT “and type in the new code given by AAC.

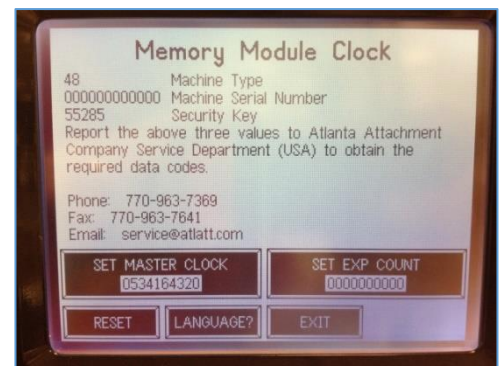
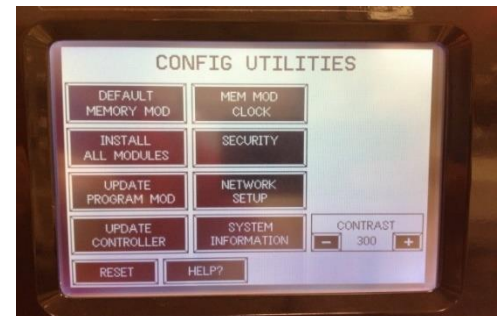

- Reset the machine. (Machine should power up normal)
- Reset all setting in the machine and program the styles back.

13. Program Update

NOTE: Very important, before starting the procedure below, go to Advanced Settings and write down all the settings shown in these screens.

A. Using a New Program Module

NOTE: Very important, before starting the procedure below, go to Advanced Settings and write down all the settings shown in these screens.



- a. Turn off power to the machine.
- b. Replace the existing Program Module with the Program Module that contains the updated program.
- c. With your finger on the screen, turn power on to the machine. When the screen changes from dark to light, remove your finger from the screen.



- d. Carefully calibrate the screen. See screen calibration.

CAUTION: Do not turn off the machine during this process for any reason, as vital information will be corrupted and it will be necessary to the call manufacturer for assistance and/or return the touch screen and module for base programming.

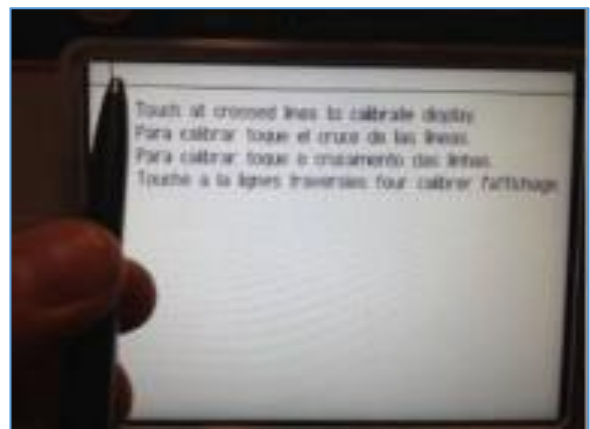

- e. Select Language
- f. Press the “Update Controller” button. Input mechanic security code 22222. This process takes up to 5 minutes and asks you to press the “Continue” button once during this time. When complete the Controller will contain the updated program.

NOTE: Continue to item “f” only if you need to reprogram original module.

- g. Turn off power to the machine.
- h. Replace the Program Module that you installed in step #2 with the original Program Module that came with the machine.
- i. With your finger on the screen, turn power on to the machine. When the screen changes from dark to light, remove your finger from the screen.

Service Instructions

- j. Carefully calibrate the screen.
- k. Press the “Update Program Mod” button. Input technician security code 22222. This process takes up to 5 minutes. When complete the original Program Module that came with the machine and the Controller will contain the updated program.

Now that the process is complete, go to Advanced Settings and verify them using the settings you wrote down at the beginning of the process. Make any necessary corrections.

B. Using a New Program Module Updating Machine Type and Memory

NOTE: Very important: 1 before starting the procedure below, go to Advanced Settings and write down all the settings shown in these screens. Call Atlanta Attachment Technical Services, during normal business hours for assistance with Engineering Code for item 5 below.

1. Turn off power to the machine.
2. Replace the existing Program Module with the Program Module that contains the updated program.
3. With your finger on the screen, turn power on to the machine. When the screen changes from dark to light, remove your finger from the screen.
4. Carefully calibrate the screen, by touching the intersecting lines at the top left and bottom right, then pick the desired language
5. Press the “Update Memory Module” button and you will be asked for an Engineering Code; that must be provided by Atlanta Attachment.
6. Press the “Update Controller” button. Input mechanic security code (3xxxx). This process takes up to 5 minutes and asks you to press the “Continue” button once during this time. When complete the Controller will contain the updated program.

Now that the process is complete, go to Advanced Settings and verify them using the settings you wrote down at the beginning of the process. Make any necessary corrections.

C. Using a New Program Module to update Original Module

NOTE: Very Important – Before starting the procedure below, go to Advanced Settings and write down all the settings shown in these screens.

1. Turn off power to the machine.
2. Replace the existing Program Module with the Program Module that contains the updated program.
3. With your finger on the screen, turn power on to the machine. When the screen changes from dark to light, remove your finger from the screen.
4. Carefully calibrate the screen.

Service Instructions

5. Press the “Update Controller” button. Input mechanic security code (3xxxx). This process takes up to 5 minutes and asks you to press the “Continue” button once during this time. When complete the Controller will contain the updated program.
6. Turn off power to the machine.
7. Replace the Program Module that you installed in step #2 with the original Program Module that came with the machine.
8. With your finger on the screen, turn power on to the machine. When the screen changes from dark to light, remove your finger from the screen.
9. Carefully calibrate the screen.
10. Press the “Update Program Mod” button. Input technician security code (xxxxx). This process takes up to 5 minutes. When complete the original Program Module that came with the machine and the Controller will contain the updated program.

Now that the process is complete, go to Advanced Settings and verify them using the settings you wrote down at the beginning of the process. Make any necessary corrections.

D. Using a New Program and Additional Modules

NOTE: Very Important – Before starting the procedure below, go to Advanced Settings and write down all the settings shown in these screens.

1. Turn off power to the machine.
2. Replace the existing Program Module with the Program Module that contains the updated program.
3. Unplug all numbered I/O modules from the SBUS cable. Do not unplug the Program, Data/Memory, or Adaptors.
4. With your finger on the screen, turn power on to the machine. When the screen changes from dark to light, remove your finger from the screen.
5. Carefully calibrate the screen.
6. Press the “Update Controller” button. Input mechanic security code (3xxxx). This process takes up to 5 minutes and asks you to press the “Continue” button once during this time. When complete the Controller will contain the updated program.

Now that the process is complete, go to Advanced Settings and verify them using the settings you wrote down at the beginning of the process. Make any necessary corrections.

E. Update a -004 Screen with a New Program Module

NOTE: Very Important – Before starting the procedure below, go to Advanced Settings and write down all the settings shown in these screens.

1. Turn off power to the machine.

Service Instructions

2. Replace the existing Program Module with the New Program Module that contains the updated program.
3. Turn power on to the machine.
4. On the “Controller Software Error” screen, press “Copy Program Module to Controller” button in the lower right corner of the page.
5. On the “System Mechanic Security” screen enter code “33333” and press “enter”.
6. When the “Warning” screen appears, press “continue”. The screen will go blank – DO NOT TURN OFF POWER.
7. When the upload is complete the machine will “Reset” itself.

F. Update a -004 Screen with New Program Module that has not had a Revision change

NOTE: Very Important – Before starting the procedure below, go to Advanced Settings and write down all the settings shown in these screens.

1. Turn off power to the machine.
2. Replace the existing Program Module with the New Program Module that contains the updated program.
3. With your finger on the screen, turn power on to the machine. When a message appears under your finger, remove your finger from the screen.
4. Carefully calibrate the screen by touching the screen at all four corners at the cross lines with the tip of a pen.
5. Select a language from the list.
6. In the “System Mechanic Security” screen enter code “33333” and press “enter”.
7. In the “Controller Setup” screen press “continue”
8. In the “Config Utilities” screen press the “Copy Program Module To Controller” button.
9. Wait for the “Program Module Check” to finish.
10. When the “Warning” screen appears press “continue”. The screen will go blank – DO NOT TURN OFF POWER.
11. When the upload is complete the machine will “Reset” itself.

Service Instructions

G. Update a -004 Screen with New Program using a Laptop

NOTE: Very Important – Before starting the procedure below, go to Advanced Settings and write down all the settings shown in these screens.

Before starting, make sure you have a Windows laptop with .NET 3.5 or later and a USBA-USBB cable that looks like the one on the picture



1. Install the SBus 4 Downloader software and program on your laptop.

- A. Use the Dropbox link above to save “SBus4 Downloader Setup.msi” to your desktop (close the website’s signup window if needed).

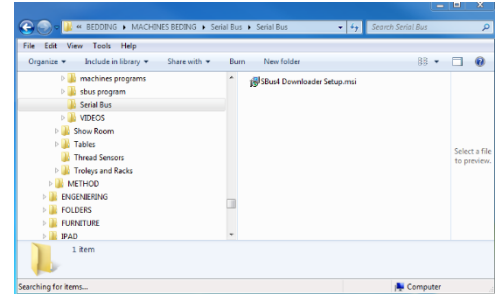

We use Dropbox for file hosting because Outlook won’t allow .msi attachments.

<https://www.dropbox.com/s/lik7e99fif1zzi1/SBus4%20Downloader%20Setup.msi?dl=0>

- B. Run this .msi setup file and follow the steps to install the program. When finished, it should create a shortcut on your desktop called SBus4 Downloader.

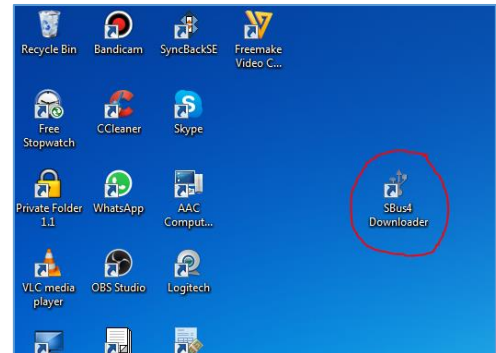

- C. Get the new program. Example: example: 1278_8G_105.zip .

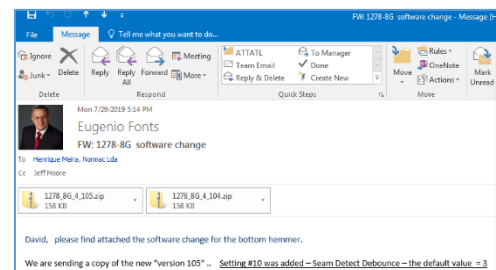

- D. Load the program in a directory in your computer. Do not unzip the file.

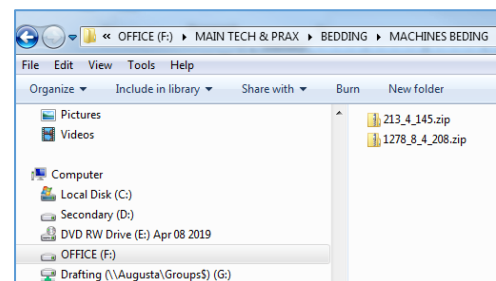

Service Instructions

2. Download a new program to the Controller.

- A. Hook up your USB cable from your laptop to the COM port on 4080-004 controller.



- B. Power up the machine and run the SBus4 Downloader program. Make sure they have been connected for 10 seconds or so (this lets Windows auto-detect the controller). When connecting to the controller for the first time, it may take Windows some extra time to set up the USB drivers – just keep an eye on the system tray and it should report when the device is ready.

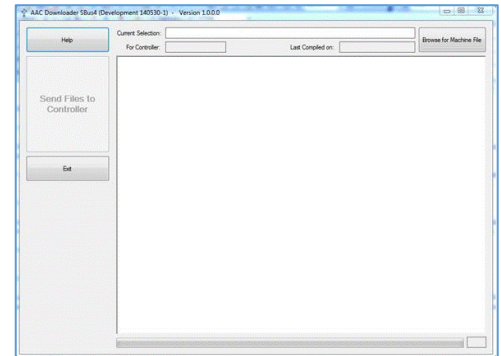

- C. Then press “Browse for Machine File” on upper right Column and choose the program that you saved to your computer earlier. Example: “1278_8_105.zip”

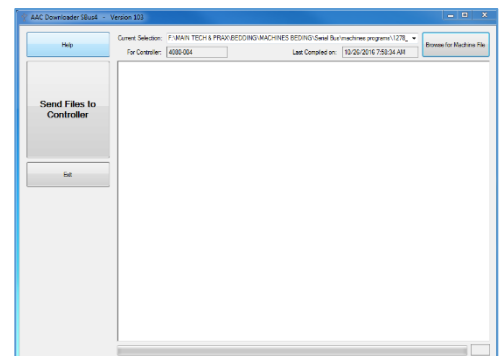

- D. Press “Send Files to Controller” and it should take less than 60 seconds to finish the download. During the download, it is normal for the controller screen to fade and/or show colored stripes.

Once the controller powers up, you can shut down the downloader and disconnect the USB cable.

If the software you uploaded is a different version than what is in the program module, it will prompt you with a program version conflict. Choose to copy from the controller to the program module. It will automatically erase, program, and verify the program module.

14. Technical Screens

A. Introduction

The touch screen is divided into two major categories:

- Functions accessible to the operator and
- Advanced functions accessible to the technician.

The advanced functions consist of five security levels: Supervisor, Mechanic, Chief Mechanic, Technician, and Engineer.

To access the technical functions, select [SET UP] from the [READY] Screen



The [SET UP 2] appear.

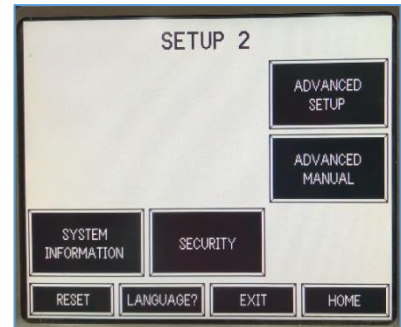

A Mechanic Security code must be entered to enter the [ADVANCE SET UP] and [ADVANCE MANUAL] Screens. The key code may be changed to any 5-digit number at the [SECURITY] screen.

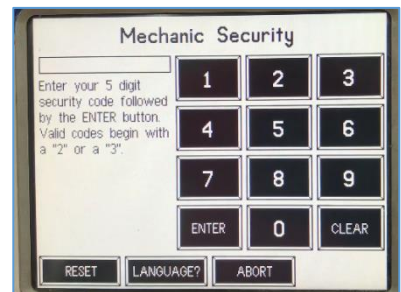

Using the correct key code will allow the 2 Technical Screens.

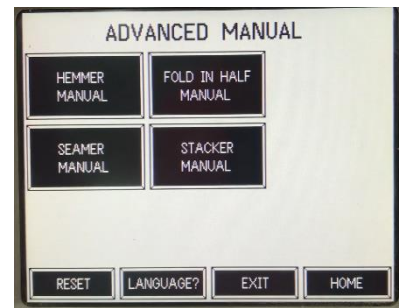
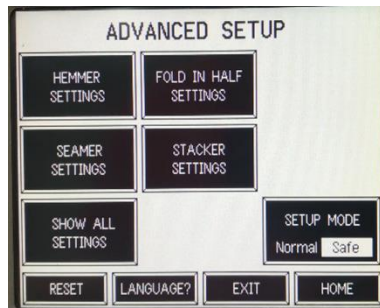

Service Instructions

B. Advanced Set Up,

This button takes you to the Advanced Functions screen. It is locked with a password. It is only to be use by technicians.



This button selection gives access to all available settings for the machine.

NOTE: All objects on Settings screens 1, 2, 3 to 10 are buttons that take you to a setting screen that will allow you to adjust the setting and will give a brief description of how the setting works.



1. Hemmer Basic Settings

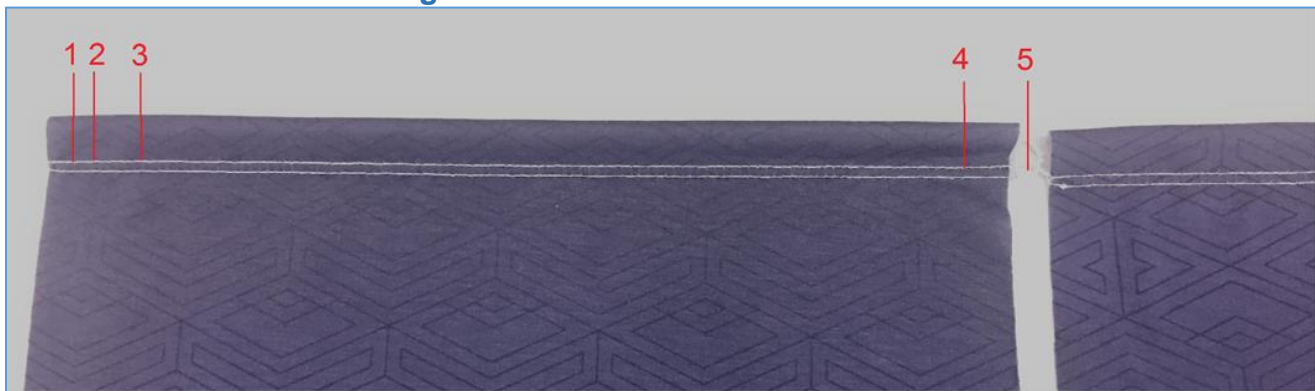

1 = Presser foot down
 2 to 3 stitches after beginning
 Too early: Gatering at the beginning
 Too late: Extra large stitches at the beginning

2 = Puller pressure off
 2 or 3 stitches after presser foot down
 Too early: Thread break (chain wrap around looper)
 Too late: Long stitches on the beginning

3 = Chain cutter leading edge
 3/8 to 1/4 inches thread chain at the beginning
 Too early : Chain too long
 Too late: Cutting sleeve

4 = Presser foot up, puller pressure on
 2 stitches before trailing edge
 Too early : Long stitches at the end
 Too late: Thread wrap and break

5 = Trailing edge cut
 3/8 chain length
 Too early : Cuts the material
 Too late : Chain too Long

Hemmer Settings 1

#1 Set Up Page Display Mode:

#2 Piece count display Mode

#3 Hem Lead Edge detection time

#4. Foot Down Delay: Time from the sew eye seeing the leading edge of the sleeve till the presser foot drops. The foot should drop at the first stitch in the sleeve. If set too early, it will cause thread breaks.

#5. Foot Up Delay: Time from the sew eye seeing the trailing edge of the sleeve till the presser foot lifts to allow chaining. The foot should lift at the last stitch in the sleeve. If set too late it will cause thread breaks.

#6 Puller Slow Speed Delay. Puller changes from chaining speed to Sewing speed.

#7 Puller Fast Speed Delay. Puller change form sewing speed to chaining speed.

#8 Hem Left needle Thread detection Delay. Allows the sewing head to get to full speed before enabling the thread detector.

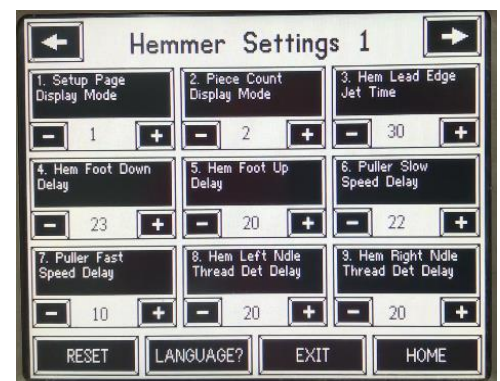

Service Instructions

#9 Hem Right needle Thread detection Delay: Allows the sewing head to get to full speed before enabling the thread detector.

Hemmer Settings 2

#10 Hem Looper Thread detection Delay. Allows the sewing head to get to full speed before enabling the thread detector.

#11 Hem Leading Edge Cut Delay: This setting allows the user to control the amount of time from the sew eye seeing the leading edge of a sleeve till the leading-edge chain chop occurs. The higher the number the shorter the length of chain.

#12 Hem Trail Edge Cut Delay: This setting allows the user to control the amount of time from the sew eye seeing the trailing edge of a sleeve till the trailing edge chain chop occurs. The lower the number the shorter the length of chain.

#13. Hem Double Cut time: Time of gap from the ends of the trailing and leading-edge chains. If gap is smaller than this setting, only the leading-edge cut will occur. A single cut between sleeves is preferred.

#14. Hem Chain Knife Down Time: Time the knife stays in the down position. Too small prevents the knife from cutting reliably, too large causes the leading-edge chain to wad up in front of the knife.

#15 Hem conveyor off time Out: Controls how long the conveyor continues to run after the last sleeve is loaded.

#16 Hem Head Off time Out: Controls how long the head runs after the trailing edge of the sleeve clears the sew eyes.

#17 Hem Maximum Length: Controls how long the head can run without showing a jam error.

#18 Hem Minimum length

Hemmer Settings 3

#19 Hem to Fold Jam Time: Control how long the fold in half eye can stay uncovered before showing a hemmer unfolded jam message.

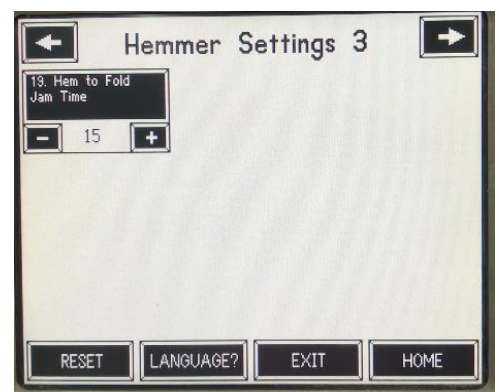
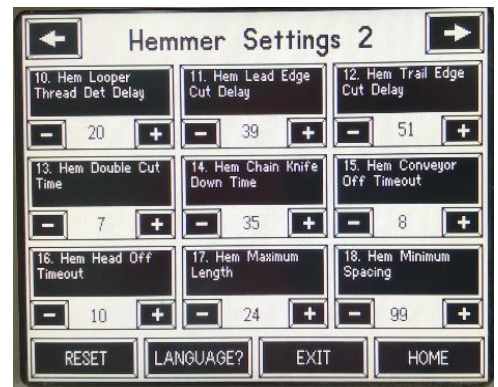

Service Instructions

2. Fold In half Basic Setting

Fold in Half Setting 4

#20 Folding Mode: Set the operating mode of the fold in half section. Can be set to automatic or fold to size. Refer to Transfer 1 Stop eye on page 78 for details

#21 Fold Lead Edge Clamp Middle Delay: Controls when the clamp plate moves to the middle position after the sleeve leading edge covers the fold in half eyes.

#22 Fold Lead Edge Clamp down Delay: Controls when the clamp plate moves to the closed position after the sleeve leading edge covers the fold in half eye.

#23 Fold Lead Edge Clamp up Delay: Controls when the clamp plate moves to the open position after the sleeve leading edge cover the fold in half eye

#24 Fold Folder Air Delay: Controls when the folder air is turned on after the sleeve leading edge covers the fold in half eye

#25 Fold Transport 1 Clamp down Fealty: Controls when the Transport 1 clamp comes down after the trailing edge of the sleeve uncovers the fold in half eye. This controls the edge of the sleeve alignment.

#26 Fold Transport 1 Clamp up Delay: Controls when the transfer 1 clamp is lifted after the clamp reaches the Transport 1 out sensor.

#27 Fold Transport 1 out Delay: Controls when the Transport 1 clamp begins to move to the out position. Setting needs to be long enough to let the clamp get down before moving the sleeve.

#28 Fold Transport 1 Stop Rev time: Controls the slow down and stop of transport 1 in fold to Size mode

Fold in Half Setting 5

#29 Fold Transport 1 Stop Forward time: Controls the slow down and stop of transport 1 in fold to Size mode

#30 Fold Top Align Jet on time: Controls the length of time the top alignment jet is on.

#31 Fold Transport 2 Enable: Controls the operation of transport 2

#32 Fold Transport 2 Rotate Enable: Controls the operation of the transport 2 clamp rotation.

#33 Fold Transport 2 out Delay: Controls the time interval of the transport 2 clamp move down before moving to the seamer head.

#34 Fold Transport 2 Clamp up Delay: Controls the time interval to allow the finger clamp to extract form under the seamer foot before raising the transport 2 clamp.

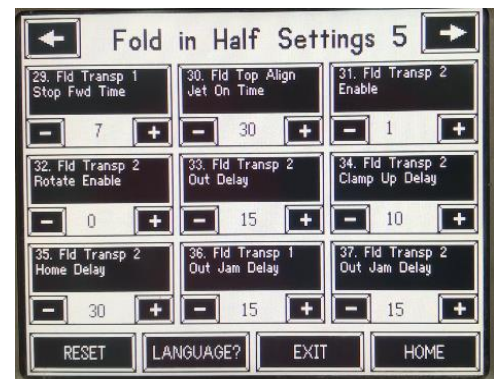
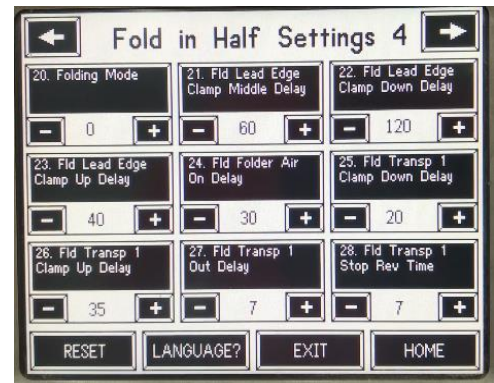

#35 Fold Transport 2 Home delay: Controls the time interval to allow the transport 2 carriage to return to the home position

#36 Fold Transport 1 out Jam Delay: Controls: the time interval to allow transport 1 to reach the out position sensor with our reporting and error.

#37 Fold Transport 2 out Jam Delay: Controls the time interval to allow transport 2 to reach the out position sensor without reporting an error

Fold in Half Setting 6

#38 Fold Transport 2 Home Jam time: Controls the time interval to allow transport 2 to return to the home position with pout reporting an error

#39 Fold to Seamer Jam Enable. Controls the jam error function for transport 2

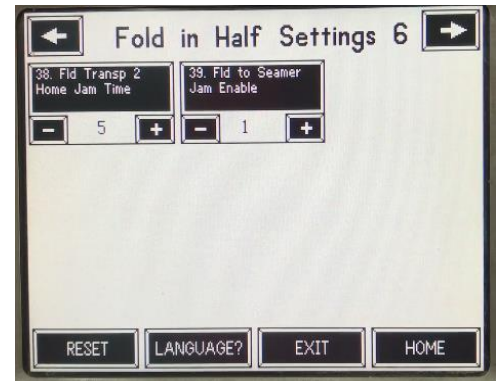

3. Seamer Basic Settings

Seamer Settings 7

#40 Seam Guide Pivot Enable: It activate the function of pivoting of the Sean guide. See Seam Guide Adjustments for more details on page 52

#41 Seam Guide Straight Delay; Controls the delay of the guide wheels lowering to allow the start of the seam to be sew straight before the wheels turn the sleeve.

#42 Seam Conveyor Arm down Delay: Controls the time interval form the seamer cycle beginning and the front conveyor arm lowering onto the sleeve.

#43 Seam Conveyor Arm up Delay
Controls when the front arm raises after the trailing edge clears the seamer sew eye

#44 Seam Sew Head Start Delay
It is the time after the Sew Eye is covered until the sewing head start.

#45 Seam Straight Sew Time: Control the time when the guiding wheel start to pivot

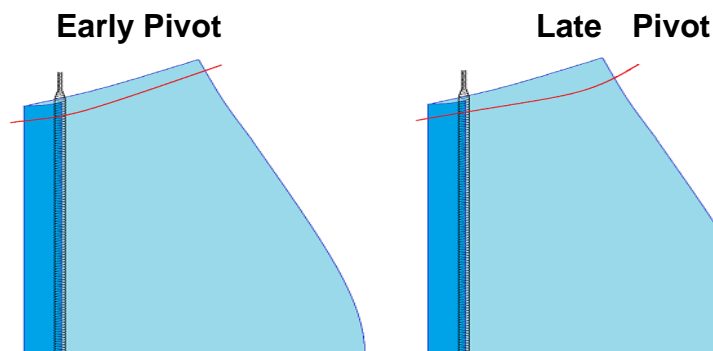
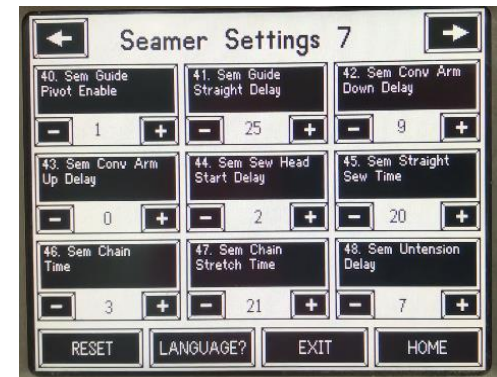

Service Instructions

#46 Seam Chain time: Controls the time interval the seamer head continues to run after the sleeve trailing edge clears the seamer sew eye

#47 Seam Chain Stretch time: Controls the time the conveyor stretched the chain until the knife cut it.

#48 Seam “no tension” Delay: Controls when the needle thread tension release come on to make the chain easier to pull in to the thread plate tube.

Seamer Settings 8

#49 Seam Chain Knife down Time: Controls the time interval of the chain cutting knife. If the time is too short the knife will not cut cleanly.

#50 Seam Back latch On time: Controls the time interval the back latch vacuum is on at the start of the seamer sewing. If this is too short you will have a knot at the beginning of the seam.

#51 Seam trim Vacuum On time: Controls the time interval the turn vacuum on after the trimming to get the waste can

#52 Seam Sew Eye Jam Time: Controls how long the seamer sew eye can be covered before a Jam error is reported.

#53 Seam to Stacker Jam Time: Controls the time interval to allow the sleeve to move from the seamer conveyor to the stacker conveyor without getting a jam error. Most common cause of that error is because the chain has not been cut properly

#54 Seam Needle Thread Detection time: Controls the time allowed for the needle thread to get to speed before enabling the detector.

#55 Seam Up Looper thread detector Delay: Controls the time allowed for the up Looper thread to get to speed before enabling the detector.

#56 Seam Low Looper Thread Detector delay: Controls the time allowed for the Low looper thread to get to speed before enabling the detector.

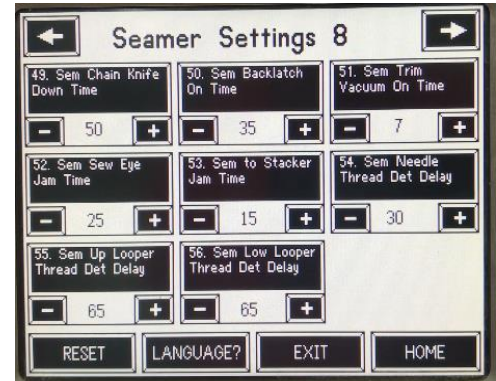

Seamer Settings 9

#57 Stacker Transfer Wheels Down Delay: Controls the time interval after the leading edge cover the seam conveyor eye. You want to have a least $\frac{3}{4}$ of the sleeve in the conveyor belt before the wheel come down

#58 Stacker Transfer Wheel Up Delay: Controls how long the transfer wheels stay down to move the sleeve onto the seamer conveyor.

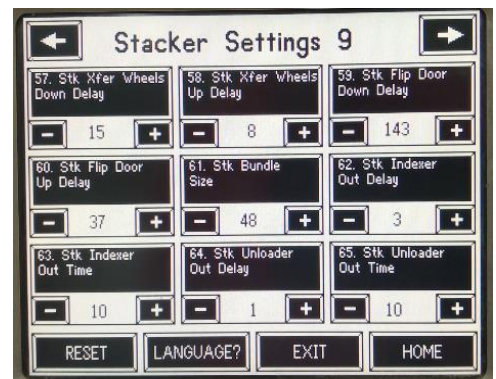

Service Instructions

#59 Stacker Flip Door down Delay: Controls the time interval after the stacker eye is covered until the stacker door stacks the sleeve.

#60 Stacker Flip Door up delay:

#61 Stacker Bundle Size: Controls how many sleeves are stacked per bundle

#62 Stacker Indexer out Delay: Controls the time interval from the stacker door stacking the last sleeve in the bundle until the indexer moves the bundle.

#63 Stacker Indexer Out time: Controls the time interval the indexer is on.

#64 Stacker Unloader Out Delay: Controls the time interval from the unloader been activated and the begin moving

#65 Stacker Unloader Out time: Controls the length of time the unloader signal is on.

4. Stacker Basic Settings

Stacker Settings 10

#66 Stacker Conveyor of Delay: Controls how long the stacker conveyor runs after the sleeve clears the eye

#67 Stacker Transfer Eye Jam Delay: Controls how long the stacker transfer eye can be covered before a jam error is reported.

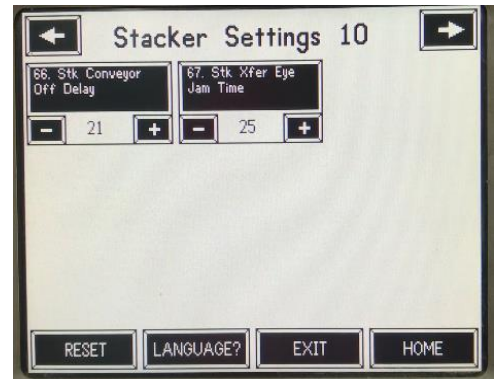

5. Show All Settings

Shows the current parameter values being used by the machine. It doesn't show the function, only the value. Before any program or module change, take notes of these values or a picture in case of any program issues.

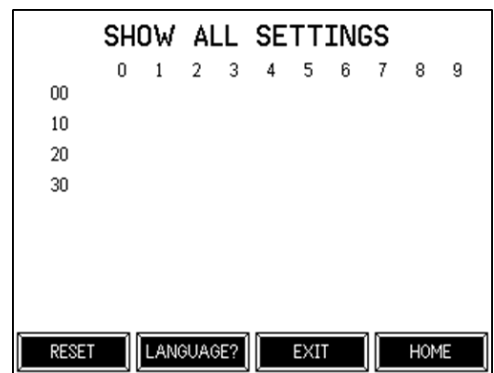

C. Advanced Manual

ATTENTION: Be extremely careful while manually activating output devices since this will activate various parts of the machine without any interlocking or safety controls of the main program. This may in some cases cause damage to the machine or to personnel
 This section Shows Manual Outputs and Manual Inputs



Advance Manual is divided into 4 areas: Hemmer, Fold in Half, Seamer and Stacker.

NOTE: While testing input devices the machine WILL NOT start in automatic mode.

The eyes, foot pedals, and proximity switches can be checked

A double line below the name of an input device is used to denote a change in its state.

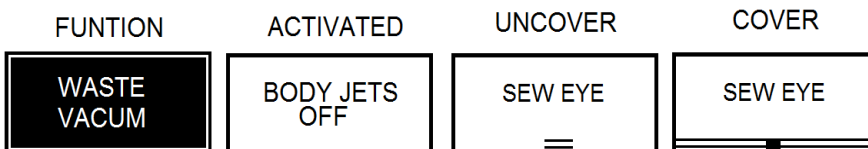

An example is when you manually cover the sew eye a double line below SEW EYE appears.

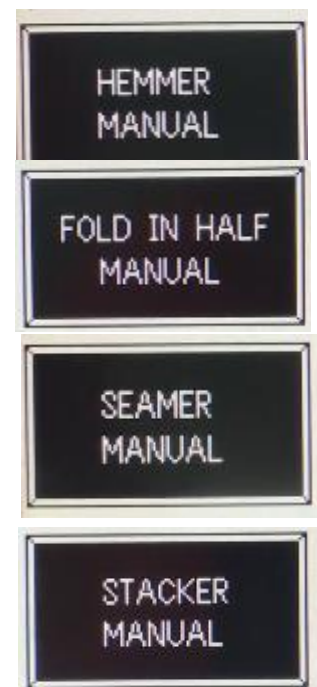

D. Style

The STYLE button shows the current style being used. Pressing the STYLE button will take you to the two pages listing the 15 available styles. At the bottom of the page are ADVANCED and RECALL SETTINGS buttons.

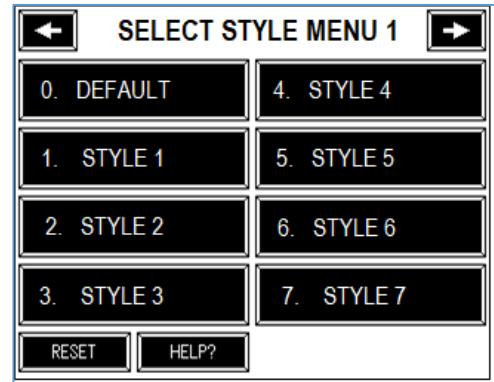

Edit the Style

- Press the ADVANCED button.
- The security keypad will appear.
- Enter the mechanic's security code and press ENTER.
- The screen will go back to the STYLE page selected.
- Press EDIT NAMES to change the style name. The name can be a combination of letters, numbers, or symbols including spaces. The page will show the current name in the box with four buttons around it. The buttons to the left and right of the box move the cursor left or right. The buttons on the top and bottom of the box increment or decrement through the alphabet, numbers, and symbols. When the Style Name is complete, press exit
- SAVE SETTINGS button will save all of the current parameter settings under that style.
- RECALL SETTINGS will install the last set of parameters saved to that style.



15. Expiration Count 911

Expiration Count Code "911" is not an error that can be resolved without assistance from Atlanta Attachment.

- Machine has displayed this error as the result of someone removing or installing modules incorrectly.
- Machine has completed a predetermined time-cycle set by the factory.

When contacting Atlanta Attachment via phone or e-mail, please provide this information below, as displayed on the "911" screen

- The machine type
- The machine serial number
- The security key
- The master clock

Here is what the 911 warning currently says:

Warning 911 Instructions

1. Contact the Atlanta Attachment Company Service Department (USA).

Phone: +1 (770) 963-7369

Fax: +1 (770) 963-7641

Email: techsupport@atlatt.com

2. Once in contact, provide the following information.

000 Machine Type

000000000000 Machine Serial Number

00000 Security Key

0000000000 Master Clock

To TEMPORARILY bypass this warning, press CONTINUE

A. Unlock Procedure 004 + 4A Screens

1. Power up the machine while pressing the center of the screen with your finger.
2. Once the screen becomes white, remove your finger and two lines should appear crossing in the upper left corner of the screen.
3. Calibrate the touch screen by pressing where the lines cross (all four corners) with the tip of a pencil eraser or ball point pen cap.
4. Two other lines should appear crossing in the lower right corner of the screen.
5. Calibrate the touch screen by pressing where the lines cross with the tip of a pencil eraser or ball point pen cap.
6. A language selection menu should now appear.

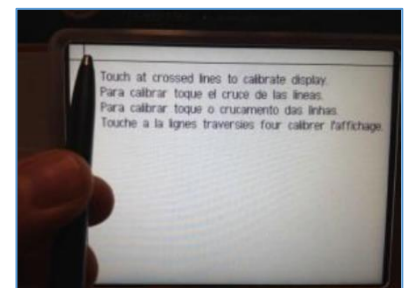

7. A MECHANIC SECURITY SCREEN should appear. Type your 5-digit security code

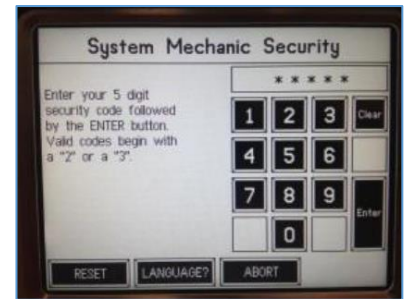

8. The Controller Setup show up; press continue



9. In the screen CONFIG UTILITIES, press EXP CODE.

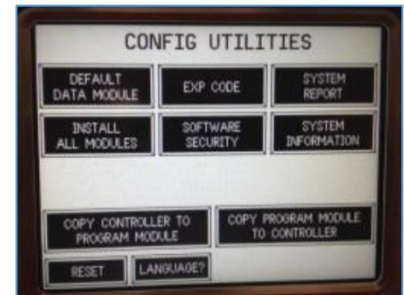

10. Report the three numbers at the top to the AAC Service department staff.

- A. The machine type
- B. The machine serial number
- C. The security key

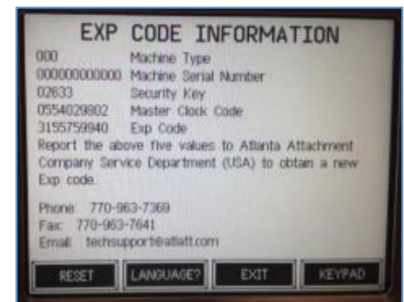

11. The AAC Service department staff will provide you with the new EXP CODE value.

12. To enter it, press the KEYPAD button at the bottom right of the screen.

13. Enter in the new EXP CODE. using the keypad on the screen. When the 15-digit number is correct, Press Enter.

14. Press RESET to reboot the machine.

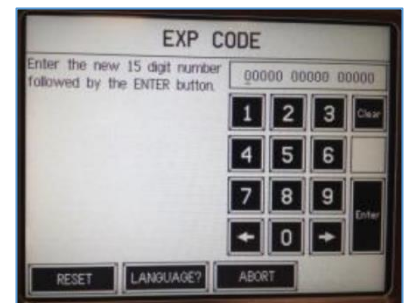

B. Unlock on old Screens

1. Power up the machine while pressing the center of the screen with your finger. Once the screen the screen becomes white, remove your finger and two lines should appear crossing in the upper left corner of the screen.

Service Instructions

2. Calibrate the touch screen by pressing where the lines cross with the tip of your finger. Release. Two other lines should appear crossing in the lower right corner of the screen.
3. Calibrate the touch screen by pressing where the lines cross with the tip of your finger. Release. A language selection menu should now appear. Touch the language that you wish to use. The Config Utility screen should appear.
4. Press the Mem Mod Clock button at the top center of the screen. A Mechanic Security screen should appear. Enter your 5-digit Mechanic code on the keypad and press Enter. The Memory Module Clock page should appear.
5. Report the three numbers at the top to the AAC Service department staff.
The machine type
The machine serial number
The security key
6. The AAC Service department staff will provide you with the new EXP COUNT value. To enter it, press the SET EXP COUNT button at the bottom right of the screen. The Exp Count screen should appear.
7. Enter in the new EXP COUNT value using then left and right buttons to position the cursor where desired. Use the Increment and Decrement buttons above and below to adjust the value under the cursor. When the 15-digit number is correct, press Enter. The Mem Mod Clock page should appear.
8. Press RESET to leave the Config mode.

3.6. Maintenance

NOTE: Always wear proper safety equipment when operating or performing maintenance on any equipment.

It is important that the machine operator read this manual and is familiar with all the functions and safety concerns of the unit before operating.

1. General Safety Instructions







Maintenance should only be performed by trained, qualified personnel. Before performing any maintenance or repair work, switch off the electrical, pneumatic, etc. power to the machine at the main source and secure it with a padlock so that it cannot be switched on again without authorization. Refer to lockout/tag out procedures

- Always wear proper safety equipment when operating or performing maintenance on any equipment.
- All recommended maintenance is for a single shift schedule; adjust as necessary for a multi-shift operation.
- Equipment should not be used for purposes other than designed or specified.
- The machine shall be switched off, come to a standstill, and be secured so that it cannot be switched on again inadvertently before starting any maintenance work whatsoever.
- Use proper lockout/tag out procedures to secure the machine against inadvertent startup.
- Remove any oil, grease, dirt, and waste from the machine, particularly from the connections and screws, when starting the maintenance and/or repair work.
- Do not use any corrosive-cleaning agents.
- Use lint-free rags.
- Retighten all screw connections that have to be loosened for the maintenance and repair work.
- Any safety mechanisms that have to be dismantled for setting-up, maintenance or repair purposes must be refitted and checked immediately after completing the work

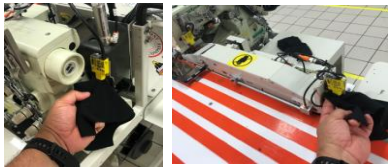

Preventive Maintenance 40 Hrs

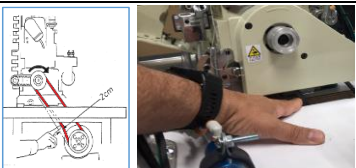





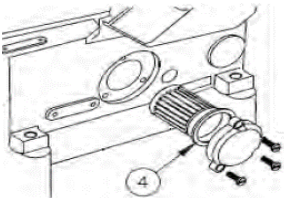

Model: 411F	Required Materials
Serial #:	
Operation: Sleeve Hemming	
Sew Head:	
Serial #:	
Needle: SNUY128GAS-70	

Open covers, remove needle plate. With an air gun blow the machine out and remove accumulated dirt in hard to reach areas	
Check Sharpness of edge trimming knives and sharpen if required. Replace if needed	
Check all reflecting tape for wear and replace if required. If tape is replaced readjust eye sensors	
Check all air cylinders for correct activation speed. Adjust flow control if required. Check pressure regulator and adjust. Main 90 psi,	
Check all mechanical assemblies. Tighten loose components if found. (Turn air pressure off and move by hand)	
Check tension of all stepping motor belts and sewing motor v-belt and adjust if necessary	
Using SF Oil for high speed sewing or equivalent place 3 drops of oil on the needle bar above and below the bushing.	
Using SF Oil for high speed sewing or equivalent place 3 drops of oil on the Seammer upper Lopper Arm	
.- Perform Daily Maintenance	

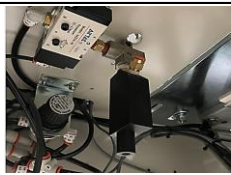

Preventive Maintenance 960 Hrs

Model: 411F	Required Materials Oil can Oil for sewing machine Clean cloth Compressed air
Serial #:	
Operation: Sleeve Hemming	
Sew Head:	
Serial #:	
Needle: SNUY128GAS-70	

Oil and filter change intervals should occur at 30 days or 200 service hours after installation and then every 6 months or 1200 service hours. If you run the unit on 24-hour shifts, factor in the hours in operation and change accordingly.	
Check filter elements in air regulator and replace if necessary	
Inspect pillow blocks and other non-sealed bearings (conveyors and rotating shafts) and apply one shot of recommended grease to each bearing/fitting.	
Open or remove doors and/or covers and inspect belt(s) for debris or wear and clean or replace as necessary.	
Remove and clean the top conveyor assembly.	
Remove and clean chain puller assembly.	
Remove vacuum assembly, clean with electronic solvent inside the vacuum generator. Check condition of 1/4" vacuum hose. Replace if necessary.	
Check cylinder mounts on stacker for looseness. Check all cylinders for flow control adjustments.	

.- Perform Weekly Maintenance

Service Instructions

4. Serial Bus Preventive Maintenance

- Clean the screen with a clean and soft cloth.



- Never use Chlorine or alcohol base products. It may deteriorate the first layer of the screen



- Clean the Modules and components; make sure the cable cabinet is organized and all modules are properly connected. Avoid any contact with oil on the system.

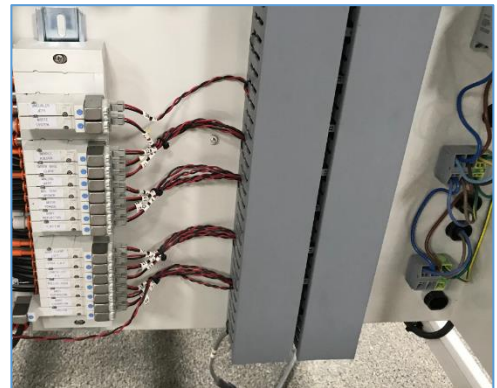

- Avoid power cables close to the serial bus than produce static to the system



- Take notes or picture of the ALL SETTINGS screen for your records.

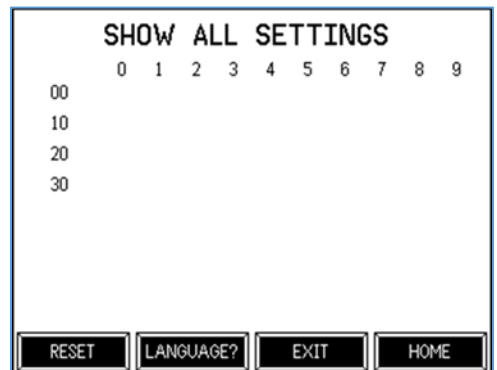

3.7. Troubleshooting

1. Screen Messages

Error	Solution
Hemmer thread break enable delay:	Delays thread break enable until head accelerates to sewing speed.
Fold-In-Half jam detection:	Time allowed between hemmer sew eye covering and F-I-H start eye covering. Adjust according to conveyor speed. Stops machine with error display.
Spacing JAM:	Time from leading edge of first sleeve until leading edge of next sleeve. Adjust to match minimum cycle time of F-I-H hardware. Intended to alert operator that sleeves may be too small to fold properly. Stops machine with error display.
Fold-in-half Trans #1 jam time out:	Delay. Time allowed for Transport #1 to move from start to proximity switch or Transport 1 Stop Eye. Stops machine with error display.
Fold-in-half Trans #2 jam time out:	Time allowed for Transport #2 to move from start to proximity switch. Stops machine with error display
Seamer thread break enable delay:	Delays thread break enable until head accelerates to sewing speed.
Seamer to stacker jam time:	Time allowed for sleeve to move from seamer chain cutter to stacker eye. Stops machine with error display.
Seamer sew eye jam time out:	Maximum time allowed for the seamer start eye to see material without generating an error. Stops machine with alarm display.
Stacker transfer eye jam time out:	Time that the stacker transfer eye may see continuous material without generating an error. Stops machine with error display.
Double cut minimum gap of chain cutter:	Sets the minimum length of time allowed for 2 complete chop cycles between trailing edge and leading edge on hemmer. If the gap between edges is too small the chopper will only make the leading-edge cut.
Transport #2 enable:	Used to disable Transport #2 for maintenance
Fold-in-half to seamer jam enable	Jam detection occurs if the seamer eye is not covered by the sleeve when Transport #2 clamp releases the sleeve at the seamer foot. This jam detection can be disabled for maintenance purposes.
Guide rotate enable:	Used to control mode of seamer guide wheels. Can be set for straight or curved seams.

2. Hemmer Troubleshooting

Problem	Solution
Chain trimmer working but not cutting.	<p>A. Check sharpness of knives and shear angle.</p> <p>B. Check air pressure while running machine. Must have 70 PSI.</p> <p>C. Check hardware for worn or loose parts.</p>
Chain trimmer not operating.	<p>A. Manually operate valve and check for pneumatic problem.</p> <p>B. Operate valve from manual screen and check if LED on valve lights. If not, check wiring for open circuit. If LED lights, check for pneumatic problem.</p> <p>C. Check setting of timers.</p>
Edge trimmer motor not operating.	<p>A. Check connection from module to motor. Replace motor.</p>
Edge trimmer not cutting properly.	<p>A. Check sharpness of knives.</p> <p>B. Check knife adjustment.</p> <p>C. Check hardware for worn or loose parts.</p> <p>D. Check setting of feed wheel and air blowers.</p>
Machine skipping or breaking thread.	<p>A. See sewing head adjustments in manual.</p> <p>B. Check for bent or burred needle.</p> <p>C. Check tension settings. Check if sewing tension opener operating properly.</p> <p>D. Check puller speed.</p> <p>E. Check levelness of puller. Check for loose or worn parts on puller.</p>
Thread chain wraps around puller roller.	<p>A. Check chain venturi operating properly.</p> <p>B. Check roller for burrs.</p> <p>C. Check clearance between roller and guard. Guard must not pinch chain against roller.</p> <p>D. Check blower #56-1. (Chain puller air jet, Pg. 128)</p>
Sewing head fails to start when sleeve reaches sewing eye. (Machine gives false thread break error)	<p>A. Check sewing motor for error code.</p> <p>B. Operate sewing motor manually and check operation.</p> <p>C.- Check Sewing eye adjustment</p> <p>D.- Check reflective tape</p>
Machine gives false thread break errors.	<p>A. Check adjustment of sensors while running in manual.</p> <p>B. Check threading of sensors.</p> <p>C. Check setting of delay, sensor enable delay.</p> <p>D. Check acceleration of sewing head.</p>
Puller Stepping motor not operating.	<p>A. Check cables and motor connector.</p> <p>B. Check plugs on back of control boxes.</p> <p>C. Plug motor cable into other box and check jog function.</p>

Service Instructions

	<p>D. If motor has no holding torque at idle, replace motor control box. (AP-28-620B)</p> <p>E. With power turned off and the stepping motor still plugged in, turn the motor shaft by hand. Moderate resistance to turning indicates a defective control box or shorted cable. Test again with motor cable unplugged at box to see if it is the box or cable.</p>
--	--

3. Fold-In-Half Troubleshooting

Problem	Solution
Clamp fails to pick up sleeve.	<p>A. Sleeves placed too close together.</p> <p>B. Sleeves too small. Check minimum sleeve size.</p> <p>C. Air blowers misadjusted or defective.</p>
Inconsistent fold-in-half alignment.	<p>A. Check air folder adjustment. Air should blow just enough to keep sleeve from collapsing on itself as it folds.</p> <p>B. Check electric eye #3 adjustments and reflective tape condition.</p> <p>C. Check skid plate condition and adjustment.</p> <p>D. Check if leading edge of hem hits or snags on the folding plate. Check direction of blower.</p> <p>E. Guide pins must all touch plate.</p> <p>F. Check flatness of hemmed sleeve as it approaches F-I-H clamp.</p> <p>G. Make sure that internal cushion on the transport #1 home is set properly. If set too hard it may not allow transport #1 to finish its stroke on the way home when sleeves are placed close together on the conveyor.</p> <p>H. Check if skid-plate is adjusted properly. Relief end must be in line with leading edge of sleeve and raised above belts to allow proper release of the bottom half of the sleeve.</p>
Transport #1 not positioning sleeve consistently. (Closer trim off varies in fold-in-half mode)	<p>A. Check #1 clamp fully extended before transport #1 begins to move.</p> <p>B. Check vertical adjustment of #1 clamp. Must not clamp too hard.</p> <p>C. Check #1 transport deceleration adjustment. Adjust for smooth operation.</p> <p>D. Check adjustment of limit switch. Must activate at end of stroke.</p> <p>E. Check #1 clamp raises off of folded sleeve without disturbing sleeve.</p> <p>F. Check adjustment of shock absorber. #1 transport must bottom out against stop for consistent positioning.</p>
Transport #2 not positioning sleeve consistently.	<p>A. Pleats in front edge of seam caused by loading sleeve too deep into seamer. Check stop position of transport #2 and adjust.</p> <p>B. Check #2 clamp not allowing sleeve to slip during positioning move. Check all adjustments.</p> <p>C. Check adjustment of limit switch. Must activate at end of stroke.</p>

4. Seamer Troubleshooting

Problem	Solution
Seamer will not run at all.	A. Check all connections to sewing motor. Check internal fuses. Check motor panel for error codes.
Seamer runs but goes to position speed and will not stop.	A. Needle up position sensor not working properly. Check sensor adjustment and reflective tape on handwheel.
Conveyor will not run while sewing but does run in jog cycle.	A. Faulty cable between sewing motor and control panel. B. Faulty cable between stepper motor control box SYNC socket and control panel. Inspect cable for bad connections. C. Faulty stepping motor control box. Replace. D. Faulty sewing motor. Replace.
Presser foot and front conveyor drop very slowly	A. Disconnect air lines at cylinder, cycle the foot lift, and check air flow. If flow is low replace defective solenoid. B. If air flow is good, replace defective flow controls.
Presser foot and front conveyor will not drop.	A. Check the output from the solenoid valve while the power is on. Replace if leaking air.
Machine will not sew when start eye is covered in automatic but the presser foot drops.	A. Faulty motor. Replace.
Conveyor runs as soon as power is turned on but sewing head is not running.	A. Disconnect AUX cable on stepper control box. If conveyor stops then troubleshoot control panel. B. If conveyor continues to run then replace stepper control box.
Machine runs-away when power is turned on.	A. Check power supply voltages to all control boxes. B. Disconnect remote cables to motor and apply power. If machine runs-away, then replace defective sewing motor. C. If machine runs-away when remote treadle cable is plugged back in then troubleshoot control panel. D. Treadle is jammed in sewing position.
Backtack has a knot on the leading edge of sleeve.	A. Insufficient vacuum for proper backtack. Check air pressure. Should be 80 psi while sewing. Check for clogged tube on throat plate, airline or vacuum generator. B. Tension-opener not working.) C. Chain-off stitch count too long causing build-up of chain on chaining finger. D. Stop delay too long causing build-up of chain on chaining finger. E. Burr on end of chaining finger tube. F. Sewing machine not stopping in correct position.

Service Instructions

	G. Leading edge vacuum stitch count too short.
Inconsistent back latch.	<p>A. Check air supply by observing pressure gauge while pressing cut button on front of the programmable controller. The pressure drop should be no more than 2-3 psi.</p> <p>B. Check for clog in vacuum ejector by removing assembly from the frame, noting how all connections were made. Remove item 3. From ejector and remove thread if necessary. Clean unit as thoroughly as possible and reinstall. Ensure all fittings are tight and do not leak, but do not over-tighten.</p> <p>C. Check connections from vacuum ejector to the throat plate to ensure there is a tight seal.</p>
Trailing edge chain too long.	<p>Chain-off stitch count too long.</p> <p>Stop delay too long.</p> <p>Electric eye not reading reflective tape consistently.</p> <p>Trailing edge chain too short.</p> <p>Chain-off stitch count too short.</p> <p>Stop delay too short.</p> <p>Conveyor not pulling sleeve properly.</p> <p>Sleeve not chaining off out from under presser foot.</p> <p>Tension-opener not working.</p>
Trailing edge chain too short.	<p>A. Chain-off stitch count too short.</p> <p>B. Stop delay too short.</p> <p>C. Conveyor not pulling sleeve properly.</p> <p>D. Tension-opener not working.</p>
Breaks thread during chain-off/cut cycle.	<p>A. Chain-off stitch count too short. Cutter cutting on sleeve.</p> <p>B. Stop delay too short. Cutter cutting on sleeve.</p> <p>C. Conveyor running too fast in jog mode.</p>
Cutter not cutting all three threads of chain.	<p>A. Chain-off stitch count too short. Cutter cutting on sleeve causing threads to go behind the Cutter.</p> <p>B. Stop delay too long. Cutter missing some threads.</p> <p>C. Conveyor running too fast in jog mode.</p>
Thread chain is blown out of tube at end of cut/backtack cycle.	<p>A. Defective pneumatic valve on vacuum generator.</p> <p>B. Clogged exhaust port on vacuum generator.</p>

5. General Troubleshooting

Problem	Cause:
1.- Chain cutter knife not cutting.	A. Manually activate solenoid valve and check operation of air cylinder. B. Disconnect air pressure and check hardware for mechanical problems. C. Check cutting blades for proper adjustment. D. Check cables and wiring for loose connections. E. Check Chop On time Delay.
2. Sewing Head will not run.	A. Check if Emergency switch is ON. B. Check cable at computer “B” socket and at motor socket. C. Check eye in front of foot.
3. Edge trimming knife not cutting cleanly.	A. Check sharpness of knives. B. Check knife adjustment. C. Check top conveyor alignment. Right conveyor belt must be parallel to line of feed and aligned with edge of fabric at edge of folder. D. Plastic roller must be kept close to top knife blade. See “adjustment to material edge trimming guide system” page
4. Foot does not raise and drop at edge of sleeve.	A. Check Foot down delay setting. B. Check electric eye adjustment at front of foot. C. Check reflective tape.
5. Machine skipping or breaking thread.	A. See adjustment in manual on page 1-17. B. Check needle thread tension too tight or too loose. C. In case of thread breaking during chaining, check the levelness of the puller to the chaining plate. This is very critical to proper chaining. Look for adjustment of levelness. D. Chaining must be checked in “MANUAL MODE”.
6. Thread chain wraps around roller.	A. Check air jets on puller bracket. B. Check that the trimmer venturi is working. C. Check roller for wear or burrs.
7. Machine stops while front electric eye remains covered.	A. Check adjustment of front eye. B. Check for thread breaks. C. Check sew eye time out setting.
8. Thread break sensor tripping without broken thread.	A. Adjust thread break detectors per manual

Service Instructions

<p>9. Machine runs-away when power is turned on.</p>	<p>A. Be sure power is turned on to all control boxes. B. Disconnect remote treadle plug at sewing motor and apply power. If machine runs-away, then replace defective Motor. C. If machine runs-away when remote treadle cable is plugged back in then replace defective AAC control box. D. Sew pedal is jammed in sewing position</p>
<p>10. Stepping motor will not run in automatic, JOG, or runs backwards.</p>	<p>A. Check the socket at the stepping motor for broken or bent pins. B. Check the stepping motor cable and plugs for loose connections. C. Check pulleys and belts. D. With power turned off and the stepping motor still plugged in, turn the stepping motor shaft by hand. Moderate resistance to turning indicates a defective stepper motor control box or shorted cable. Make this test again with the other end of the cable disconnected at the stepper motor control box to see if it is the control box or cable.</p>
<p>Problem</p>	<p>Cause:</p>
<p>1. Thread break on outside needles.</p>	<p>A. Check thread and replace if broken. B. Make sure thread is routed properly through sensor. C. Adjust tension on sensor. D. Replace or re-program sensor.</p>
<p>2. Thread break on inside needles.</p>	<p>A. Check thread and replace if broken. B. Make sure thread is routed properly through sensor. C. Adjust tension on sensor. D. Replace or re-program sensor</p>
<p>3. Thread break on looper.</p>	<p>A. Check thread and replace if broken B. Make sure thread is routed properly through sensor. C. Adjust Sensitivity of sensor (Light goes off as thread moves through it. D. Replace sensor.</p>
<p>4.- Low air pressure detected.</p>	<p>A. Air shutoff valve is closed. B. Airline is disconnected from machine. C. Air supply pressure is below 80 PSI. D. Air regulator is adjusted below 70 PSI. E. Air pressure switch is disconnected. F. Air pressure switch needs adjustment. G. Air pressure switch has failed. H. Module #5 has failed.</p>

Service Instructions

5. Possible sleeve jam. Relative setting: Jam Detect Time	A. Sleeve is jammed under the presser foot. B. Sleeve is jammed under the conveyor.
6. Stacker bypassed return limit switch. Relative setting: Stacker Switch Timeout.	A. Stacker switch timeout setting set to low. B. Possible defective limit switch.
7. Foot pedal pressed at power up or Reset.	A. Something is pressing down on the switch. B. Possible defective foot pedal.
8. Stacker limit switch has been engaged too long. Relative setting: Stacker Switch Jam Timeout.	A. Stacker is jammed at switch. B. Possible defective limit switch.
9. Sew eye is covered at automatic startup.	A. The sew eye is prevented from seeing the reflective tape. All eyes must be clear to start the machine in automatic mode. Manual can be used to remove material from under the foot. Restart in Automatic starts the machine as if it were in the middle of a sleeve. B. Possible defective sew eye. Possible Causes:
10. Sew eye has been covered too long. Relative setting: Sew Eye Timeout.	A. The sew eye is prevented from seeing the reflective tape. B. The conveyor has stopped. C. Possible jam under sew eye. D. Possible defective sew eye.
11. Stacker eye has been covered too long. Relative setting: Stacker Eye Timeout.	A. The stacker eye is prevented from seeing the reflective tape. B. The conveyor has stopped. C. Possible jam under stacker eye. D. Possible defective stacker eye

6. Efka Controller Error

General Information			
On the control	On the V810	On the V820	Signification
A1	InF A1	InF A1	Pedal not in neutral position, when turning the machine on
A2	-StoP- blinking	-StoP- blinking + symbol display	Machine run blockage
A3	InF A3	InF A3	Reference position is not set
A6	InF A6	InF A6	Light barrier monitoring
A7	Symbol blinking	Symbol blinking	Bobbin thread monitor

Programming Functions and Values (Parameters)			
On the control	On the V810	On the V820	Signification
Returns to 000 or to last parameter number	Returns to 0000 or to last parameter number	Like V810 + display InFo F1	Wrong code number or parameter number input

Serious Condition			
On the control	On the V810	On the V820	Signification
E1	InF E1	InF E1	The external pulse encoder e.g. IPG... is defective or not connected.
E2	InF E2	InF E2	Line voltage too low, or time between power off and power on too short.
E3	InF E3	InF E3	Machine blocked or does not reach the desired speed.
E4	InF E4	InF E4	Control disturbed by deficient grounding or loose contact.
E9	InF E9	InF E9	EEPROM defective.

Hardware Disturbance			
On the control	On the V810	On the V820	Signification
H1	InF H1	InF H1	Commutation transmitter cord or frequency converter disturbed.
H2	InF H2	InF H2	Processor disturbed

A. Flow Chart EFKA Error E1

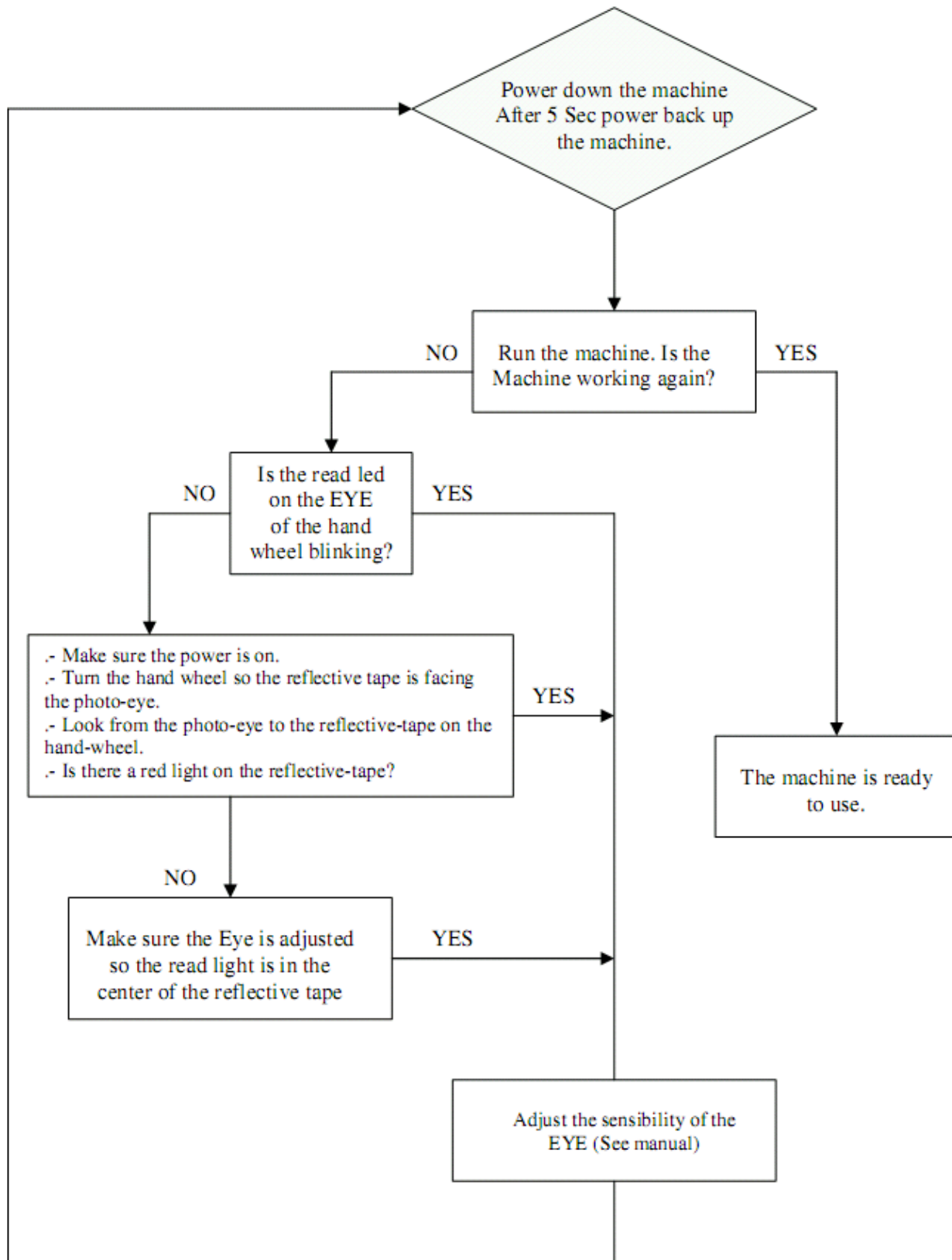

7. Panasonic D9 Controller Errors

• Information Error Code and Measurement:

Error Code	Abnormality Item	Cause of The Problem	Measure
E - 1	•Sewing machine lock	<ul style="list-style-type: none"> • Sewing machine lock • Needle sensor connector is disconnected •V-Belt has loose tension • Motor connector is disconnected • Trimmer sequence is set improperly 	<ul style="list-style-type: none"> •Check the sewing machine •Connect the needle sensor connector •Tighten the belt(See page 4) •Connect the motor connector •Confirm trimmer sequence
E - 2	•Hardware tripping in control	<ul style="list-style-type: none"> • Abnormal power supply voltage for control box •High voltage at braking form high speed 	<ul style="list-style-type: none"> •Check the power-supply voltage •Replace the control box to repair the regenerated circuit
E - 3	•Encoder signal of motor sensor is abnormal	<ul style="list-style-type: none"> • Motor connector is disconnected 	<ul style="list-style-type: none"> •Connect the motor connector •Check the wires of the motor sensor cable
E - 4	• Commutation signal of motor sensor is abnormal	<ul style="list-style-type: none"> • Motor connector is disconnected 	<ul style="list-style-type: none"> •Connect the motor connector • Check the wires of the motor sensor cable •Replace the motor
E - 5	•Abnormal motor speed	<ul style="list-style-type: none"> • Abnormal control box 	<ul style="list-style-type: none"> •Replace the control box
E - 6	•Motor over-load or lock	<ul style="list-style-type: none"> •Machine has heavy load •Motor connector is disconnected 	<ul style="list-style-type: none"> •Check the machine load. If yes, reduce the machine load. •Connect the motor connector.
E - 7	• High voltage supply	<ul style="list-style-type: none"> • Power supply voltage abnormal 	<ul style="list-style-type: none"> • Exchange control Box
E - 8	•Abnormal Solenoid.	<ul style="list-style-type: none"> •Solenoid is short-circuited 	<ul style="list-style-type: none"> •Check the solenoid.
E - 10	• Control Box memory is abnormal.	<ul style="list-style-type: none"> • EEPROM has wrong data. 	<ul style="list-style-type: none"> • Reset EEPROM by using (RESET) node.

E - 11	•Abnormal Communication	<ul style="list-style-type: none"> •The console is cable was plugged in after power on. 	<ul style="list-style-type: none"> • Plug in the console cable with power off, then power on.
SAFE	Safety Switch	<ul style="list-style-type: none"> Trimming protection Safety switch broken Safety switch setting incorrect (open or close) 	<ul style="list-style-type: none"> Correct trimming device to be used Check if the switch is damaged Usually set to close, use A14 to adjust.

5. ASSEMBLY DRAWINGS & PARTS LISTS

The materials contained herein are confidential and proprietary information of Atlanta Attachment Company. In addition to any confidentiality and non-disclosure obligations that currently exist between you and Atlanta Attachment Company, your use of these materials serves as an acknowledgment of the confidential and proprietary nature of these materials and your duty not to make any unauthorized use or disclosure of these materials.

See Separate Parts Manual



Atlanta
PARTS DEPOT

One-Stop Shopping
For Expendable Replacement Parts for AAC & Other Bedding Equipment Suppliers
Toll Free: **1-866-885-5100**
www.atlantapartsdepot.com • sales@atlantapartsdepot.com

Atlanta Attachment Company (AAC) Statement of Warranty

Manufactured Products

Atlanta Attachment Company warrants manufactured products to be free from defects in material and workmanship for a period of eight hundred (800) hours of operation or one hundred (100) days whichever comes first. Atlanta Attachment Company warrants all electrical components of the Serial Bus System to be free from defects in material or workmanship for a period of thirty six (36) months.

Terms and Conditions:

- AAC Limited Warranty becomes effective on the date of shipment.
- AAC Warranty claims may be made by telephone, letter, fax or e-mail. All verbal claims must be con-firmed in writing.
- AAC reserves the right to require the return of all claimed defective parts with a completed warranty claim form.
- AAC will, at its option, repair or replace the defective machine and parts upon return to AAC.
- AAC reserves the right to make the final decision on all warranty coverage questions.
- AAC warranty periods as stated are for eight hundred (800) hours or one hundred (100) days whichever comes first.
- AAC guarantees satisfactory operation of the machines on the basis of generally accepted industry standards, contingent upon proper application, installation and maintenance.
- AAC Limited Warranty may not be changed or modified and is not subject to any other warranty expressed or implied by any other agent, dealer, or distributor unless approved in writing by AAC in advance of any claim being filed.

What Is Covered

- Electrical components that are not included within the Serial Bus System that fail due to defects in material or workmanship, which are manufactured by AAC are covered for a period of eight hundred (800) hours.
- Mechanical parts or components that fail due to defects in material or workmanship, which are manufactured by AAC.
- Purchased items (sewing heads, motors, etc.) will be covered by the manufacturers (OEM) warranty.
- AAC will assist in the procurement and handling of the manufacturers (OEM) claim.

What Is Not Covered

- Parts that fail due to improper usage, lack of proper maintenance, lubrication and/or modification.
- Damages caused by; improper freight handling, accidents, fire and issues resulting from unauthorized service and/or personnel, improper electrical, plumbing connections.
- Normal wear of machine and parts such as Conveyor belts, "O" rings, gauge parts, cutters, needles, etc.
- Machine adjustments related to sewing applications and/or general machine operation.
- Charges for field service.
- Loss of time, potential revenue, and/or profits.
- Personal injury and/or property damage resulting from the operation of this equipment.

Declaración de Garantía

Productos Manufacturados

Atlanta Attachment Company garantiza que los productos de fabricación son libres de defectos de material y de mano de obra durante un periodo de ochocientos (800) horas de operación o cien (100) días cual llegue primero. Atlanta Attachment Company garantiza que todos los componentes del Serial bus son libres de defectos de material y de mano de obra durante un periodo de treinta y seis (36) meses.

Términos y Condiciones:

- La Garantía Limitada de AAC entra en efecto el día de transporte.
- Reclamos de la Garantía de AAC pueden ser realizados por teléfono, carta, fax o correo electrónico. Todo reclamo verbal tiene que ser confirmado vía escrito.
- AAC reserva el derecho para exigir el retorno de cada pieza defectuosa con un formulario de reclamo de garantía.
- AAC va, según su criterio, reparar o reemplazar las máquinas o piezas defectuosas devueltas para AAC.
- AAC reserva el derecho para tomar la decisión final sobre toda cuestión de garantía.
- Las garantías de AAC tiene una validez de ochocientas (800) horas o cien (100) días cual llega primero.
- AAC garantiza la operación satisfactoria de sus máquinas en base de las normas aceptadas de la industria siempre y cuando se instale use y mantenga de forma apropiada.
- La garantía de AAC no puede ser cambiado o modificado y no está sujeto a cualquier otra garantía implicada por otro agente o distribuidor menos al menos que sea autorizado por AAC antes de cualquier reclamo.

Lo Que Está Garantizado

- Componentes eléctricos que no están incluidos dentro del sistema Serial Bus que fallen por defectos de materiales o de fabricación que han sido manufacturados por AAC son garantizados por un período de ochocientas (800) horas.
- Componentes mecánicos que fallen por defectos de materiales o de fabricación que han sido manufacturados por AAC son garantizados por un periodo de ochocientas (800) horas.
- Componentes comprados (Motores, Cabezales,) son protegidos debajo de la garantía del fabricante.
- AAC asistirá con el manejo de todo reclamo de garantía bajo la garantía del fabricante.

Lo Que No Está Garantizado

- Falla de repuestos a raíz de uso incorrecto, falta de mantenimiento, lubricación o modificación.
- Daños ocurridos a raíz de mal transporte, accidentes, incendios o cualquier daño como resultado de servicio por personas no autorizados o instalaciones incorrectas de conexiones eléctricas o neumáticas.
- Desgaste normal de piezas como correas, anillos de goma, cuchillas, agujas, etc.
- Ajustes de la máquina en relación a las aplicaciones de costura y/o la operación en general de la máquina.
- Gastos de Reparaciones fuera de las instalaciones de AAC
- Pérdida de tiempo, ingresos potenciales, y/o ganancias.
- Daños personales y/o daños a la propiedad como resultado de la operación de este equipo.



TRAINING

Check	Description	Time Hrs.
	Basic Function - Review Of Machine <ul style="list-style-type: none"> • Sequence of operation • Manual And Automatic Operation For Technicians • Serial Bus 	4
	Edge Trimming Knife <ul style="list-style-type: none"> • Knife adjustment, disassembly and adjustments. • Proper setting and changing blades. • Height of assembly to folder.1 	2
	Hemmer Section Adjustment <ul style="list-style-type: none"> • Foot lift / head lift switch. • Air electric switch in conjunction with foot lift. • Chain cutter assembly basic function. • Maintenance of chain trimmer. • Proper adjustments of knife blades. • Setting of chain trimmer to sewing head. • Basic function. • Oil and filter change intervals. • Timing and adjustments. 	3
	Folder on Hemmer <ul style="list-style-type: none"> • Basic function. • Mechanical breakdown adjustment • Alignment procedure. • Adjust hem size procedure. 1 	2
	Fold In half Section Adjustments	3
	Transfer Section Adjustments	2
	Seamer Adjustments <ul style="list-style-type: none"> • Foot lift / head lift switch. • Air electric switch in conjunction with foot lift. • Chain cutter assembly basic function. • Maintenance of chain trimmer. • Basic function. • Oil and filter change intervals. • Timing and adjustments. 	2
	Waste System Assembly Function and Operation <ul style="list-style-type: none"> • Disassemble vacuum assembly; adjust for proper air volume; set to proper PSI (90 psi.). • Discuss how to perform preventative maintenance. • Proper tube connection. 	2
	Thread Detectors Hemmer and Seamer <ul style="list-style-type: none"> • Proper alignment. • Adjust sensitivity. • Operation procedure 	1
	Stacker <ul style="list-style-type: none"> • Basic operation. 	1



	<ul style="list-style-type: none">• Adjustment of door and tray alignment.	
	Sew Off Machine <ul style="list-style-type: none">• Start review of any questions thus far.	2
	Electrical and Pneumatics <ul style="list-style-type: none">• Diagram evaluation.	5
	Discuss Operation Of Stepped Boxes <ul style="list-style-type: none">• Puller drive system, stepping motor controller.• Conveyor drive system, stepping motor controller.• Hemmer driver stepping motor controller.• Adjustments and functions of each.• Setting of jog feature of each.• Power connections and AMP settings of each.	3
	Electric eyes <ul style="list-style-type: none">• Discuss the ease of setting the eyes in correct position.• Easy removal of eyes.• Set gain on electric eyes.• Maintenance of reflective tape.	2
	Troubleshoot Unit	4
	Basic Function - Review Of Machine with Operator <ul style="list-style-type: none">• Sequence of operation• Operator instruction and breakdown• Manual And Automatic Operation For Operator	2
	Evaluate any questions.	2

Participants:

Instructor: _____ **Date:** _____



Air Filters.....	59	Patents & Patents Pending.....	0
Air Supply.....	12	Pneumatic.....	0, 3, 6, 35, 59, 74
Blowers.....	61	Presser Foot.....	41
Calibration.....	90	Pressure Regulator.....	59
CLOCK	21	Production.....	8
Contents.....	1	RESET	20, 21, 91, 116
Cutting Margin.....	36	Safety Instruction.....	0
Edit the Style.....	114	Screen Error Messages.....	122
Efka.....	72, 131	Serial Bus.....	12, 84
Electric Eyes.....	14, 76	Serial Number.....	8
Electrical.....	0, 3, 5, 35, 66, 95, 138	Set Up.....	106
Emergency Stop.....	13, 17, 20	SET UP.....	23
EXP CODE.....	116	Sewing Head Lubrication.....	10
Expiration Count 911.....	115	Show All Settings.....	112
Eye Sensor Adjustment.....	76	Solenoid Valve.....	60
First Aid.....	2	START.....	23, 66
Foot print.....	8	Stepping Motors.....	14, 68
Ground.....	66	Style.....	114
Installation.....	9	STYLE.....	24, 114
INSTALLATION.....	7	Technical Data.....	8, 84
JOG button.....	69, 71	Thread Break Detectors.....	67
Lockout/Tagout Program.....	35	Thread Detectors.....	11
Main Circuit Breaker.....	66	Thumbwheels.....	69, 70
Main Power Contactor.....	66	Top Conveyor.....	See
Maintenance.....	5, 33, 35, 76, 118, 137, 138	Touch-Screen.....	20
MECHANIC SECURITY SCREEN.....	116	Troubleshooting.....	122
Needle Thread Sensor.....	19, 26, 67	Update Controller.....	99
Options & Classes.....	7	V-belt.....	10
Panasonic.....	75, 133	Waste System.....	13, 20
Parts and Components.....	9, 86	Waste Venturi.....	61



Atlanta Attachment Company Inc.
362 Industrial Park Drive
Lawrenceville, GA 30046
Phone: +1 (770) 963-7369
www.atlatt.com

Printed in USA
Digital Version of this Manual Available at:
http://atlatt.com/tech_manuals.php

Atlanta Attachment Company 362 Industrial Park Drive, Lawrenceville, GA 30046 E-mail: Sales@atlatt.com Phone: +1 (770) 9637369