



Model

1335E

Revision 4.2 Updated July 8, 2024

Technical Manual & Parts Lists

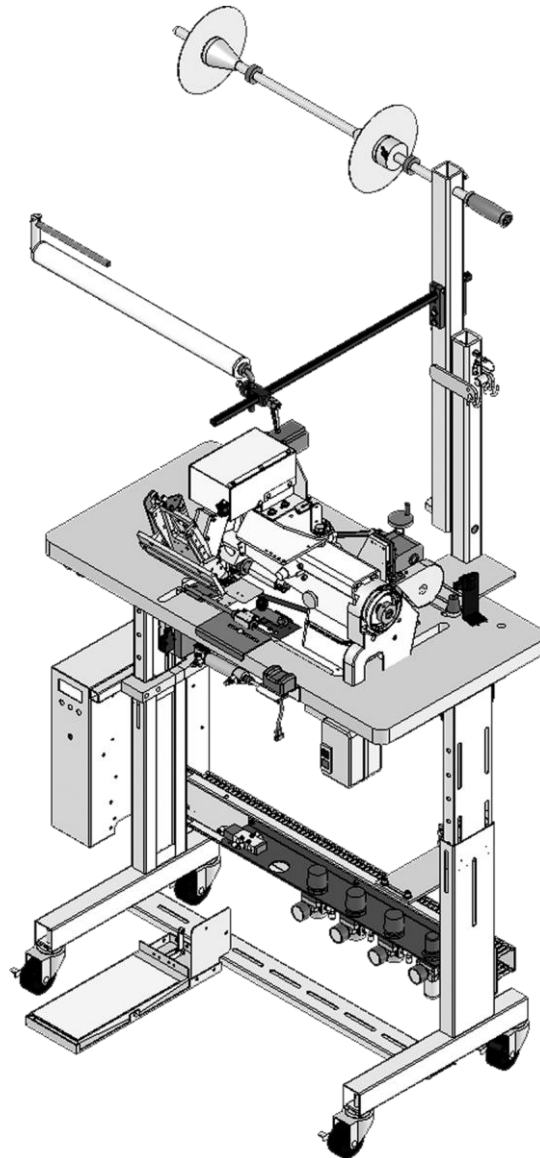

Atlanta Attachment Company

362 Industrial Park Drive

Lawrenceville, GA 30046

770-963-7369 • www.atlatt.com

ATLANTA ATTACHMENT COMPANY, INC.

Confidential and Proprietary Information

The materials contained herein are confidential and proprietary information of Atlanta Attachment Company. In addition to any confidentiality and non-disclosure obligations that currently exist between you and Atlanta Attachment Company, your use of these materials serves as an acknowledgment of the confidential and proprietary nature of these materials and your duty not to make any unauthorized use or disclosure of these materials.

All materials contained herein are additionally protected by United States Copyright law and may not be used, disclosed, reproduced, distributed, published or sold without the express written consent of Atlanta Attachment Company, which consent may be withheld in Atlanta Attachment Company's sole discretion. You may not alter or remove any copyright, trademark or other notice from copies of these materials.

IMPORTANT
It is important to read and understand the information contained within this manual before attempting to operate the machine. Atlanta Attachment Co., Inc. shall not be held liable for damage resulting from misuse of the information presented within, and reserves the right to change the information contained within, without prior notification.

Contents

Important Safety Instruction	0
Liability	1
Safety Equipment on the Machines	2
Protective Eyewear	3
Important Notices.....	4
Maintenance	6
Repair	7
A Word to the End User.....	8
Safety Precautions.....	8
General Machine Data	9
Electrical & Pneumatic Specifications.....	9
Installation & Setup	9
Control Box Operation.....	9
Main Control Box:	9
Stepper Control Box	10
Efka Control Box	11
Basic Machine Operation.....	11
Loading the Roll Holder	12
Loading and Adjusting the Folder	12
Adjusting the Edge Guide.....	12
Loading the Panel	12
Sewing the Panel with Rounded Corners.....	12
Sewing the Panel with Straight Corners	13
Adjusting the Corner Ruffles	13
Finishing the Panel.....	13
Efka Control Box Settings	13
General Machine Adjustments.....	14
Air Pressure.....	14
Sewing Head	14
Ruffler Drive.....	14
Puller Drive.....	14
General Machine Maintenance	15
Daily.....	15
Weekly	15
Electric Eye Sensor Adjustment	15
Reflective Tape Maintenance	15

Technical Manual & Parts Lists

1335M Folder Spacer Reference Chart.....	16
1335E Parameter Settings	17
Spare Parts Kit	18
Assembly Drawings & Parts Lists	19
11335E Manual Ruffler	21
1335922 Stand & Motor Assembly	24
1335924 Stepper Box Assembly.....	26
1335M-2000A Ruffler Assembly	28
1335183 Stripper Blade Assembly	30
1335184 Puller Assembly	32
1335332 Ruffler Cylinder Lift Assembly	34
1335716 Pneumatic Shelf Assembly	36
1335930 Roll Holder Assembly.....	38
1335710 Sewing Head Assembly	40
1335923 Zero-Max Mount Assembly.....	42
1335M-113 Foot Pressure Assembly.....	44
1335M-2200 Ruffler Mount Angle Assembly.....	46
1335M-2300B Pivot Assembly.....	48
1335E-500 Control Box Assembly.....	50
1335M-6000 Footlift Assembly.....	51
33008708 Ball Bearing Disc Assembly	52
1335E-PD Pneumatic Diagram.....	53
1335E-WD Wiring Diagram.....	54

Important Safety Instruction



This part of the Instruction Material is provided for the safe use of your equipment. It contains important information to help work safely with the unit and describes the dangers inherent in machinery. Some of these dangers are obvious, while others are less evident.

Mandatory Information

All persons operating and/or working on the 1335E Manual Ruffler Workstation should read and understand all parts of the Safety Instructions. This applies, in particular, for persons who only operate and/or work on the unit occasionally (e.g. for maintenance and repair). Persons who have difficulty reading must receive particularly thorough instruction.

Scope of the Instruction Material

- The Instruction Material comprises:
- Safety information
- Operator Instructions
- Electrical and Pneumatic diagrams

And may also include;

- A list of recommended spare parts
- Instruction Manual(s) for components made by other manufacturers
- The layout and installation diagram containing information for installation

Intended Use

Our machines are designed and built in line with the state of the art and the accepted safety rules. However, all machines may endanger the life and limb of their users and/or third parties and be damaged or cause damage to other property, particularly if they are operated incorrectly or used for purposes other than those specified in the Instruction Manual.

Exclusion of Misuse



Non-conforming uses include, for example, using the equipment for something other than it was designed for, as well as operation without duly installed safety equipment. The risk rests exclusively with the end user.

Conforming use of the machine includes compliance with the technical data, information and regulations in all parts of the complete Instruction Material, as well as compliance with the maintenance regulations. All local safety and accident prevention regulations must also be observed.

Liability

The machine should only be operated when in perfect working order, with due regard for safety and the potential dangers, as well as in accordance with the Instruction Material. Faults and malfunctions capable of impairing safety should be remedied immediately. We cannot accept any liability for personal injury or property damage due to operator errors or non-compliance with the safety instructions contained in this booklet. The risk rests exclusively with the end user.

The Instruction Material should always be kept near the machine so that it is accessible to all concerned.

The local, general, statutory and other binding regulations on accident prevention and environmental protection must also be observed in addition to the Instruction Material. The operating staff must be instructed accordingly. This obligation also includes the handling of dangerous substances and provision/use of personal protective equipment.

The Instruction Material should be supplemented by instructions, including supervisory and notification duties with due regard for special operational features, such as the organization of work, work sequences, the personnel deployed, etc.

The personnel's awareness of the dangers and compliance with the safety regulations should be checked at irregular intervals.

Choice and Qualification of Personnel

Ensure that work on the machine is only carried out by reliable persons who have been appropriately trained for such work - either within the company, by our field staff or at our office - and who have not only been duly appointed and authorized, but are also fully familiar with the local regulations. Work on the machine should only be carried out by skilled personnel, under the management and supervision of a duly qualified engineer.

This not only applies when the machine is used for production, but also for special work associated with its operation (start-up and maintenance), especially when it concerns work on the hydraulic or electrical systems, as well as on the software/serial bus system.

Training

Everyone working on or with the machine should be duly trained and informed with regard to correct use of the safety equipment, the foreseeable dangers which may arise during operation of the machine and the safety precautions to be taken. In addition, the personnel should be instructed to check all safety mechanisms at regular intervals.

Responsibilities

Clearly define exactly who is responsible for operating, setting-up, servicing and repairing the machine. Define the responsibilities of the machine operator and authorize him to refuse any instructions by third parties if they run contrary to the machine's safety. This applies in particular for the operators of machines linked to other equipment. Persons receiving training of any kind may only work on or with the machine under the constant supervision of an experienced operator. Note the minimum age limits permitted by law.

A Word to the Operator

The greatest danger inherent in our machines: is that of fingers, hands or loose clothing being drawn into a machine by live, coasting or rotating tools or assemblies or of being cut by sharp tools or burned by hot elements.

ALWAYS BE CONSCIOUS OF THESE DANGERS!

Safety Equipment on the Machines



All machines are delivered with safety equipment, which shall not be removed or bypassed during operation.

The correct functioning of safety equipment on machines and systems should be checked every day and before every new shift starts, after maintenance and repair work, when starting up for the first time and when restarting (e.g. after prolonged shutdowns).

If safety equipment has to be dismantled for setting-up, maintenance or repair work, such safety equipment shall be replaced and checked immediately upon completing the maintenance or repair work. All protective mechanisms shall be fitted and fully operational whenever the machine is at a standstill or if it has been shut down for a longer period of time.

Damage

If any changes capable of impairing safety are observed in the machine or its mode of operation, such as malfunctions, faults or changes in the machine or tools, appropriate steps must be taken immediately, the machine switched off and a proper lockout tagout procedure followed. The machine should be examined for obvious damage and defects at least once per shift. Damage found shall be immediately remedied by a duly authorized person before resuming operation of machine.

The machine should only be operated when in perfect working order and when all protective mechanisms and safety equipment, such as detachable protective mechanisms, emergency STOP systems, etc. are in place and operational.

Faults or Errors

The machine must be switched off and all moving or rotating parts allowed to come to a standstill and secured against accidental restart before starting to remedy any faults or errors.

Signs on the Machine

Safety and danger signs on the machine should be observed and checked at regular intervals to ensure that they are complete and undamaged. They should be clearly visible and legible at all times.

Clothing, Jewelry, Protective Equipment

Long loose hair, loose-fitting clothes, gloves and jewelry, including rings, should be avoided in order to avoid injuries due to being caught, drawn in and wound up inside the machine.

Protective Eyewear

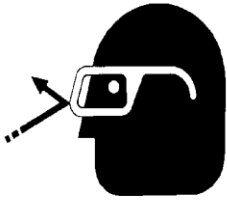

Protective eyewear that has been tested by the local authorities should be worn whenever there is a possibility of loose or flying objects or particles such as when cleaning the machine with compressed air.

Tools

Always count the number of tools in your possession before starting work on the machine. This will allow you to check that no tools have been left behind inside the machine. Never leave a tool in the machine while working.

Oils, Lubricants, Chemicals

Note the applicable safety regulations for the product used.

No Smoking, Fire, Explosion Hazard

Smoking and open flame (e.g. welding work) should be prohibited in the production area due to the risk of fire and explosions.

Workplace

A clear working area without any obstructions whatsoever is essential for safe operation of the machine. The floor should be level and clean, without any waste.

The workplace should be well lit, either by the general lighting or by local lights.

Emergency STOP

The emergency STOP buttons bring all machine movements to a standstill. Make sure you know exactly where they are located and how they work. Try them out. Always ensure easy access to the nearest emergency STOP button while working on the machine.

First Aid

1. Keep calm even when injured.
2. Clear the operator from the danger zone. The decision of what to do and whether to seek additional assistance rests entirely with you, particularly if someone has been trapped.
3. Give First Aid. Special courses are offered by such organizations as the employers' liability insurance association. Your colleagues should be able to rely on you and vice versa.
4. Call an ambulance. Do you know the telephone numbers for the ambulance service, police and fire service?

Important Notices

Reporting and Fighting Fires

Read the instructions posted in the factory with regard to reporting fires and the emergency exits. Make sure you know exactly where the fire extinguishers and sprinkler systems are located and how they are operated. Pass on the corresponding information to the firemen when they arrive. Ensure there are enough signs to avoid fire hazards.

The following fire extinguishers may be used:

- Dry powder extinguishers, ABC fire-extinguishing powder.
- Carbon dioxide fire extinguishers to DIN 14461 for electronic components. Great care must be exercised when using carbon dioxide fire extinguishers in confined, badly ventilated rooms (see DIN 14406 and 14270).

Isolate the machine from the power supply if a fire breaks out. Do not use water on burning electrical parts until it is absolutely certain that they have been completely disconnected from the power supply. Burning oils, lubricants, plastics and coatings on the machine can give off gases and vapors that may be harmful to your health.

A qualified person should be consulted to repair the damage after a fire.

Electrical Power Supply



Before undertaking any maintenance or repair work on the machine, switch off the electrical power to the machine at the main source and secure it with a padlock so that it cannot be switched on again without authorization.

In practice, this may mean that the technician, electrician and operator all attach their own padlock to the master switch simultaneously so that they can carry out their work safely. Locking extension plates should be available for multiple locks if required. The primary purpose for a lockout/tagout procedure is to protect workers from injury caused by unexpected energizing or start-up of equipment.

Energy sources (electrical/pneumatic/hydraulic, etc.) for the equipment shall be turned off or disconnected and the switches locked or labeled with a warning tag. It is the responsibility of the employer to establish control procedures. Follow lockout/tagout procedures before, setup and/or any service or maintenance work is performed, including lubrication, cleaning or clearance of jams.

Caution: The machine is still not completely de-energized even when the master switch is off.

- Electricity - The machine is always isolated from the electrical power supply whenever the master switch has been switched off. However, this does not apply for the power supply in the control cabinet, nor for equipment that does not draw its power via the master switch.
- Pneumatic / hydraulic energy - Almost all our machines carry compressed air. In addition to switching off the master switch, the air supply must also be disconnected and the machine checked to ensure it is depressurized before starting any work on the machine; otherwise the machine may execute uncontrolled movements.

- Kinetic energy - Note that some motors or spindles, for example, may continue to run or coast run on after being switched off.
- Potential energy - Individual assemblies may need to be secured if necessary for repair work.

Delivery of the Machine/Packaging

Note any markings on the packaging, such as weights, lifting points and special information. Avoid temperature fluctuations. Condensation may damage the machine.

Transport Damage

The packaging and machine must immediately be examined for signs of damage in transit. Such damage must be reported to the shipper/transporter within the applicable time limits. Contact Atlanta Attachment Company and/or your transport insurer immediately, if signs of damage are visible. Never operate a damaged machine.

Interim Storage

If the machine has to be stored temporarily, it must be oiled or greased and stored in a dry place where it is protected from the weather in order to avoid damage. A corrosion-inhibiting coating should be applied if the machine has to be stored for a longer period of time and additional precautions taken to avoid corrosion.

Transporting the Machine

Disconnect the machine from all external connections and secure any loose assemblies or parts. Never step under a suspended load. When transporting the machine or assemblies in a crate, ensure that the ropes or arms of a forklift truck are positioned as close to the edge of the crate as possible. The center of gravity is not necessarily in the middle of the crate. Note the accident prevention regulations, safety instructions and local regulations governing transport of the machine and its assemblies.

Only use suitable transport vehicles, hoisting gear and load suspension devices that are in perfect working order and of adequate carrying capacity. Transport should only be entrusted to duly qualified personnel.

Never allow the straps to rest against the machine enclosure and never push or pull sensitive parts of the machine. Ensure that the load is always properly secured. Before or immediately after loading the machine, secure it properly and affix corresponding warnings.

All transport guards and lifting devices must be removed before the machine is started up again. Any parts that are to be removed for transport must be carefully refitted and secured before the machine is started up again.

Workplace Environment

Our machines are designed for use in enclosed rooms: Permissible ambient temperature approx. 5 - 40 °C (40 - 104 °F). Malfunctions of the control systems and uncontrolled machine movements may occur at temperatures outside this range.

Protect against climatic influences, such as electrostatic charges, lightning strikes, hail, storm damage, high humidity, salinity of the air in coastal regions.

Protect against influences from the surroundings: no structure-borne vibrations, no grinding dust, or chemical vapors.

Protect against unauthorized access.

Ensure that the machine and accessories are set up in a stable position.

Ensure easy access for operation and maintenance (Instruction Manual and layout diagram); also verify that the floor is strong enough to carry the weight of the machine.

Local Regulations

Particular attention must be paid to local and statutory regulations, etc. when installing machines and the plant (e.g. with regard to the specified escape routes). Note the safety zones in relation to adjacent machines.

Maintenance

General Safety Instructions

The machine shall be switched off, come to a standstill and be secured so that it cannot be switched on again inadvertently before starting any maintenance work whatsoever. Use proper lockout/tagout procedures to secure the machine against inadvertent startup.

Remove any oil, grease, dirt and waste from the machine, particularly from the connections and screws, when starting the maintenance and/or repair work. Do not use any corrosive-cleaning agents. Use lint-free rags.

Retighten all screw connections that have to be loosened for the maintenance and repair work. Any safety mechanisms that have to be dismantled for setting-up, maintenance or repair purposes must be refitted and checked immediately after completing the work.

Maintenance, Care, Adjustment

The activities and intervals specified in the Instruction Manual for carrying out adjustments, maintenance and inspections must be observed and parts replaced as specified.

All hydraulic and pneumatic lines should be examined for leaks, loose connections, rubbing and damage whenever the machine is serviced. Any defects found must be remedied immediately.

Waste, Disassembly, Disposal

Waste products should be cleared from the machine as soon as possible as not to create a fire hazard. Ensure that fuels and operating lubricants, as well as replacement parts are disposed of in a safe and ecologically acceptable manner. Note the local regulations on pollution control.

When scrapping (disassembling) the machine and its assemblies, ensure that these materials are disposed of safely. Either commission a specialist company familiar with the local regulations or note the local regulations when disposing of these materials yourself. Materials should be sorted properly.

Repair

Replacement Parts

We cannot accept any liability whatsoever for damage due to the use of parts made by other manufacturers or due to unqualified repair or modification of the machine.

Repair, Electrical

The power supply must be switched off (master switch off) and secured so that it cannot be switched on again inadvertently before starting any work on live parts.

Those parts of the machine and plant on which inspection, maintenance or repair work is to be carried out must be isolated from the power supply, if specified. The isolated parts must first be checked to determine that they are truly de-energized before being grounded and short-circuited. Adjacent live parts must also be isolated.

The protective measures implemented (e.g. grounding resistance) must be tested before restarting the machine after all assembly or repair work on electric parts.

Signal generators (limit switches) and other electrical parts on the safety mechanisms must not be removed or bypassed. Only use original fuses or circuit overloads with the specified current rating. The machine must be switched off immediately if a fault develops in the electrical power supply.

The electrical equipment of our machines must be checked at regular intervals and any defects found must be remedied immediately.

If it is necessary to carry out work on live parts, a second person should be on hand to operate the emergency OFF switch or master switch with voltage release in the event of an emergency. The working area should be cordoned off and marked by a warning sign. Only use electrically insulated tools.

Ventilation/Hazardous Gases

It is the end users responsibility to ensure adequate ventilation is provided to exhaust any and all noxious or hazardous gases that may be present in the working environment.

Hydraulic and Pneumatic Systems

Work on hydraulic or pneumatic equipment shall only be carried out by persons with training, knowledge and experience of hydraulic systems. Pressure lines shall be depressurized before starting any repair work.

General Liability

Liability for machine damage and personal injury is extinguished completely if any unauthorized conversions or modifications are undertaken. The machine must not be modified, enlarged or converted in any way capable of affecting safety without the manufacturer's prior approval.

Starting Machine Movements

Read the Instruction Manual carefully to establish which keys and functions start machine movements.

A Word to the End User

The end user has sole responsibility to enforce the use of safety procedures and guards on the machine. Any other safety devices or procedures due to local regulations should be retrofitted in accordance to these regulations and/or the EC Directive on the safety of machines.

Operator's position must always be readily accessible. Escape routes must always be kept clear and safety areas should be identified.

Safety Precautions

Safety should be a constant concern for everyone. Always be careful when working with this equipment. While normal safety precautions were taken in the design and manufacture of this equipment, there are some potential safety hazards.

Everyone involved with the operation and maintenance of this equipment should read and follow the instructions in this manual.

Operate the equipment only as stated in this manual. Incorrect use could cause damage to the equipment or personal injury.

It is the owner's responsibility to make certain that the operator reads and understands this manual before operating this equipment. It is also the owner's responsibility to make certain that the operator is a qualified and physically able individual, properly trained in the operation of this equipment.

Specific safety warning decals are located on the equipment near the immediate areas of potential hazards. These decals should not be removed or obliterated. Replace them if they become non-readable.

- ALWAYS keep safety shields and covers in place, except for servicing.
- ALWAYS operate equipment in daylight or with adequate working lights.
- Follow daily and weekly checklists, making sure hoses are tightly secured and bolts are tightened.
- ALWAYS watch and avoid holes or deep depressions.
- ALWAYS wear adequate eye protection when servicing the hydraulic system and battery.
- NEVER operate a poorly maintained machine.
- NEVER allow persons to operate this machine without proper instruction.
- NEVER put hands or feet under any part of the machine while it is running.
- NEVER attempt to make any adjustments or repairs to the machine while running. Repairs or maintenance should be performed by trained personnel only.
- NEVER work under the machine unless it is safely supported with stands, blocks or a hoist and blocks.
- NEVER touch hot parts of machine.

General Machine Data

Electrical & Pneumatic Specifications

Electrical:	220 VAC, 5amp, 50/60 Hz Single Phase
Pneumatic:	70-80 PSI, 2 SCFM avg.
Sewing Head:	Consew 326S
Sewing Speed:	3500 RPM
Needle (Standard):	SNTVX7X140
Stitch Density:	6 SPI

Installation & Setup

Provide a 220VAC, single phase, 5 Amp electrical drop and 1/4" air supply line (80 PSI). Remove any shipping straps from machine. Mount and adjust the Guide Roller Assembly. Check the oil level in the oil pan.

Control Box Operation

Main Control Box:

The front of the main control box has an Auto/Manual Switch, a Manual Ruffle Pushbutton, an Unwinder Reverse Switch, a Fuse Holder, and 6 Thumbwheels. On the back is the power entry socket and an on/off switch. Be sure the on/off switch is always on.

Note: The on/off switch only switches one line and does not make the box safe to work on. Always disconnect the main power cord before servicing the control box.

The Auto/Manual Switch turns on the automatic ruffling cycles for the corners. When this switch is in Manual, the ruffling is disabled and the machine will only sew, trim, and foot lift.

The Manual Ruffle pushbutton turns on one ruffle cycle and also functions as the Reset button for the automatic cycle. Pushing this button once will turn on the ruffle cycle. Pushing it a second time will reset the automatic program and cause the ruffle hardware to reset and go to its "Home" position. Use this button to reset the ruffler after adjusting the ruffle size.

The Unwinder will run whenever the Treadle is not in the neutral position (either sewing or heeled back) and the Loop Eye is seeing the gusset material.

The Fuse Holder fuses the entire machine. Replace the fuse with a 5A Slow Blow 250v as necessary.

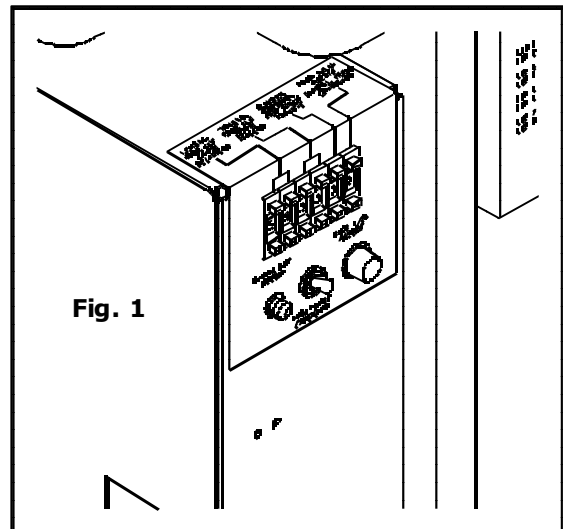

Thumbwheels

The first thumbwheel (#1) on the left sets the stitch count for the SLOW START feature after the last ruffle. This reduces the sewing speed for a few stitches to help the material feed to the puller before the machine goes to high speed. The stitch count equals twice the number shown on the thumbwheel. This feature can be turned off by setting thumbwheel #1 to "0".

The second Thumbwheel controls the sewing speed of the sewing head during ruffling. Each increment is approximately 100 rpm. The normal setting is "6".

The third and fourth Thumbwheels together make up the Stop count for the corners. This is the stitch count (00-99 stitches) from when the front eye uncovers until the sewing stops in the corner to start the ruffling cycle. This should be adjusted to stop the panel so that when the corner turn is finished the right edge of the panel is flush against the edge guide. If, after turning the corner, the right edge of the panel is to the left of the edge guide, decrease the stitch count to stop the panel sooner. If, after turning the corner, the right edge of the panel is to the right of the edge guide, increase the stitch count to stop the panel closer to the foot.

The fifth Thumbwheel sets the number of ruffles to be sewn in each corner. Adjust this setting along with the ruffle size to achieve desired corner finish.

The sixth Thumbwheel sets the number of stitches sewn in each ruffle and is adjusted according to the ruffle size. There should be enough stitches to sew to the folded edge of each ruffle.

Stepper Control Box

The Ruffler box is located under the table and has three Thumbwheels on the front which are set to synchronize the Ruffler to the sewing head. The number is proportional to the stitch LENGTH and is not affected by sewing speed. The 10-turn potentiometer is used to set the speed of the Ruffler during the feed in to pleat and feed out to make the next ruffle. It is set to maximum and is locked in place by a small locking lever. Unlock to adjust.

The box has an on/off switch on the back where the power cord plugs in. Leave this switch on all the time.

Note: The on/off switch only switches one line and does not make the box safe to work on. Always disconnect the main power cord before servicing the control box.

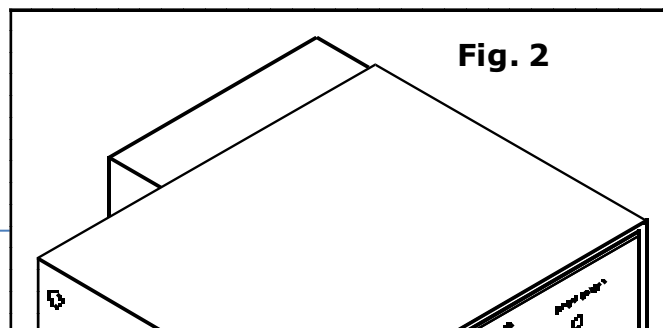

Efka Control Box

The sewing machine is powered by the Efka motor controller located under the table. It has its own on/off switch which should be left on at all times. It also has some small buttons and LED's on the front to indicate the enabled functions. The only LED that should be on is the second to last from the bottom which sets the control to stop the machine needle down at neutral treadle and needle up after full heel back. The functions can be changed upon power up or after a full heel back. The control box has been preprogrammed to operate with the Ruffler. If the box were replaced, the new box would need to be programmed according to the included parameter list in order to function properly. Notice that the sewing head does not stop at normal needle up (lockstitch heads) position after full heel back, but stops at needle top dead center to allow more room for loading thicker material (the head actually turns in reverse for a moment).

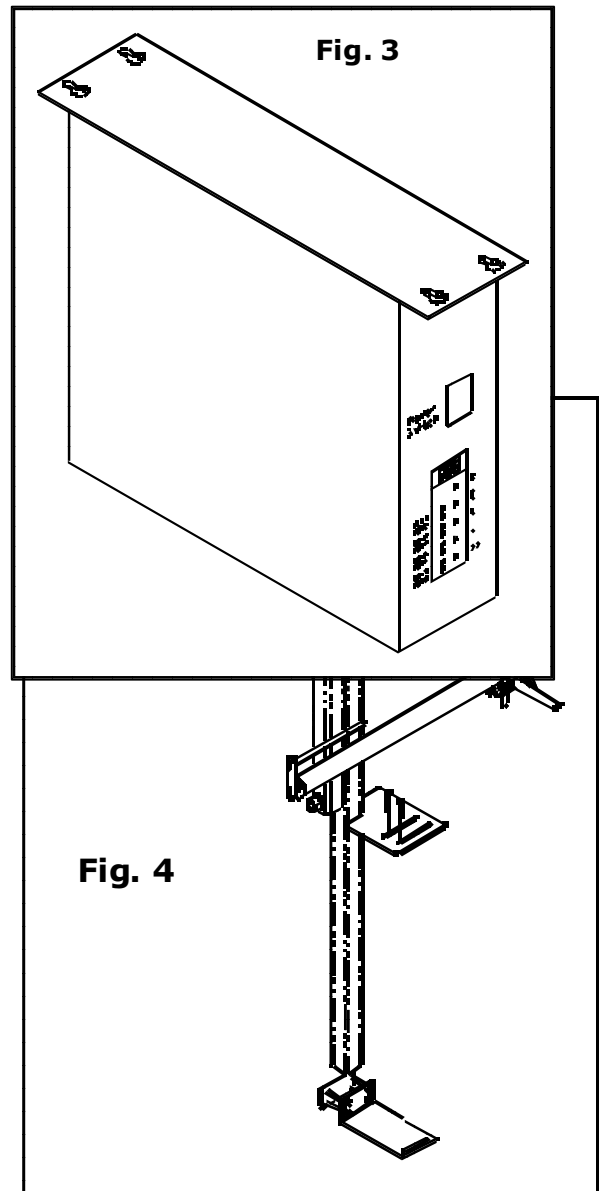

Basic Machine Operation

Loading the Roll Holder

Remove the outer disc from the upper rod. Place a roll of material on the rod and replace the outer disc. Feed the material over the top roller and down to the folder with the good side toward the sewing head. (When making continental foundations, the good side will face the operator)

Loading and Adjusting the Folder

Feed the gusset through the top portion of the folder with the flange to the right and under the right flange guide. Adjust the left guide to make a snug fit to the gusset width. Adjust the folder left or right as necessary to set the desired stitch margin. Normally, with the folder positioned to its right most position in its slots, a 6" wide gusset will be centered on the needle. The folder spacers should be sized as required to fit the thickness of the gusset. Extra spacers can be ordered to fit any thickness gusset from 1/8" to 9/16". Adjust the lower portion of the folder in the same manner.

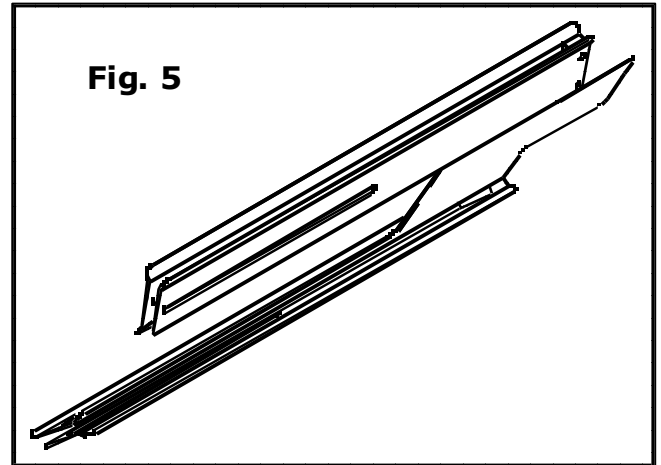

Adjusting the Edge Guide

The edge guide located on the front of the table should be set so its left edge aligns with the right edge of the gusset. This is the guide for the right edge of the panel.

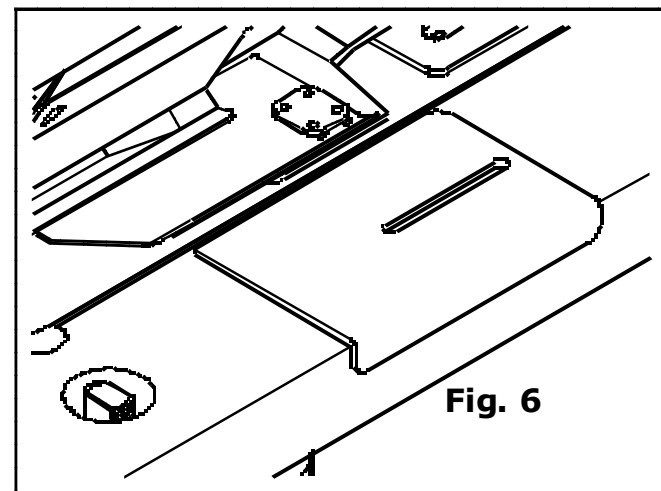

Loading the Panel

Heel back the treadle or step on the foot lift pedal to raise the presser foot. Swing in the stripper blade and the folder/ruffler assembly. Be sure the sensor at the back of the swing-out bracket is lit indicating that the bracket is all the way in to the detent. Activate the "Wipe" switch to raise the folder for easier loading. Pull the gusset through the folder, under the presser foot and under the puller. Activate the "Wipe" switch again to lower the folder. Load the panel under the gusset with the center of the short side even with the needle and the edge of the panel against the edge guide. Lower the presser foot. Be sure the Auto/ Manual switch is in its Auto position (up). Be sure the folder is "Down". The automatic cycle will not function while the folder is up.

Sewing the Panel with Rounded Corners

Set thumbwheel #5 to any ruffle setting between 1 and 6 as desired.

Sew the panel to the corner being sure not to get your hands in the way of the electric eye mounted under the table which must "see" the edge of the panel as it nears the presser foot. The machine will stop automatically at the corner. Go to neutral treadle as you position your hands for turning. Place your right hand on the panel near the presser foot and your left hand about 1 foot to the left on the panel. Treadle forward and allow the machine to make the first ruffle sewing straight. Begin to rotate the panel as the rest of the ruffles are formed. Try to turn an equal amount with each ruffle so that when the ruffles are complete the panel has turned 90 degrees and the right edge of the panel is resting against the left edge of the edge guide. The ruffles can be made one at a time by going to neutral treadle between each ruffle. Complete all four corners.

Sewing the Panel with Straight Corners

Set thumbwheel #5 to "7" for 1 ruffle per side, "8" for 2 ruffles per side, or "9" for 3 ruffles per side. Sew the panel to the corner being sure not to get your hands in the way of the electric eye mounted under the table, which must "see" the edge of the panel as it nears the presser foot. The machine will pause momentarily as the ruffler engages and then continue to sew straight as it makes the ruffles.

After the last ruffle is finished on the first side of the corner the machine will continue to sew slow stitches based on the setting of thumbwheel #1. The number of slow stitches sewn is equal to twice the setting of thumbwheel #1. Setting the thumbwheel to "0" will disable this slow sew function. After the slow stitches the machine will stop with the presser foot lifted. Turn the panel 90 degrees. Release and depress the treadle. The foot will drop and the machine will again make slow stitches based on the setting of thumbwheel #1, and then begin making the ruffles on the second side of the corner. When the ruffles are complete the machine will resume sewing at treadle speed. Adjust the stop count as necessary to achieve the desired corner finish.

Adjusting the Corner Ruffles

The ruffles should be set so the outer edge of the gusset lays flat for taping. A typical ruffled gusset will have ruffles which butt against each other without overlapping or gaps between them. Adjust Thumbwheels #5 and #6 and the ruffle size knob to achieve the desired finish. Euro style gussets typically have 3 or 4 small ruffles with extra stitches between them.

Finishing the Panel

After the last corner, sew the panel until the starting edge of the gusset is almost to the presser foot. Stop and activate the "Wipe" switch to raise the folder. Cut the gusset so that there is enough overlap of gusset for finishing. Swing out the stripper blade. Fold the trailing edge of the gusset under itself, lay it on top of the starting edge and oversew the two together. Heel back and remove the panel. Reload the gusset under the foot and puller and lower the folder. Note: The automatic functions will not operate with the folder up!

Efka Control Box Settings

The Efka control has been preprogrammed to operate the sewing head in conjunction with the ruffler. The maximum sewing speed has been preset to 4000 RPM. The maximum sewing speed can be temporarily reduced by holding in the "-" button on front of the control box while sewing. To restore maximum speed use the "+" button. Be sure the needle down LED is the only LED lit on front of the control box. The LED's can be changed only immediately after power on or a full healback. Refer to the appendix for complete Efka programming parameters.

General Machine Adjustments

Air Pressure

Set all air supply pressure regulators (Right to left):

Main Pressure:	70 PSI
Puller Pressure:	30 PSI
Ruffle Blade Pressure:	10 PSI
Foot Sew Pressure:	15 PSI

Sewing Head

See the manufacturer's manuals for normal adjustments and parts. The presser foot spring pressure should be set very light so that the ruffling blade can feed under the foot while ruffling. The Efka motor should be set for stopping needle down at neutral treadle to help hold the ruffle in place while turning the corners. The auxiliary foot pressure cylinder should be set to provide added foot pressure while sewing straight.

Ruffler Drive

Set the Ruffler blade position left to right. The slot in the Ruffler blade should align with the sewing needle. Loosen the 4 clamp screws and adjust ruffler blade left or right as needed.

Set the Ruffler blade IN position so that the front edge of the blade is even with the needle when the ruffler drive is positioned at the IN sensor. To position the drive at the sensor, press the manual ruffle button once and quickly tap the treadle or sew pedal. The Ruffler should position itself at the IN sensor. Adjust the sensor position in its slot, press the manual ruffle button to reset the ruffler and repeat the cycle to test the setting.

Set the Ruffler blade OUT position by turning the adjusting knob on the front cover of the ruffler drive. This controls how big each ruffle will be. After making an adjustment, always reset the ruffler by pressing the manual ruffle button twice.

The swing-out stripper blade protects the panel from the ruffler blade while ruffling so that the panel does not get pleated by the blade. It should be positioned as close to the presser foot as possible. The ruffling air pressure should be set as high as practical without it pressing the stripper blade down and pinching the panel while turning.

Puller Drive

Set the puller down position as low as practical without actually touching the cloth plate. The roller should be centered on the needle. Set the Puller air pressure as needed to provide positive feeding without the puller stalling at high speed.

General Machine Maintenance

Daily

- Clean machine at the end of every shift
- Clean lint etc. from the Looper/bobbin area on the sewing head
- Remove any threads wrapped around moving parts of the handwheel, puller, and ruffler.
- Wipe all photo eye lenses with clean, nonabrasive, dry cloth
- Use blow-off hose to get rid of excess lint, thread and other clippings
- Follow manufactures recommendations and guidelines for daily maintenance and lubricating of the sewing head.

Weekly

- Check all belts for tightness and condition. Adjust or replace as necessary.
- Check oil level in oil pan.
- Put one drop of machine oil on all moving Ruffler parts.

Electric Eye Sensor Adjustment

To adjust the sensor, first remove the clear plastic cover from the end of the sensor. There are two adjusting screws under the cover. One is labeled "GAIN" and is used to set the sensitivity of the sensor. The other screw is labeled "DO & LO" and should always be fully clockwise.

With the end of the sensor pointing at the center of the reflective tape, turn the "GAIN" screw counter-clockwise until the red LED indicator is off. Then turn the "GAIN" screw clockwise until the LED indicator comes on. Then turn the "GAIN" screw one full turn clockwise. The LED indicator should be blinking slowly. Cover the eye so that the sensor cannot see the reflective tape and the LED should go off.

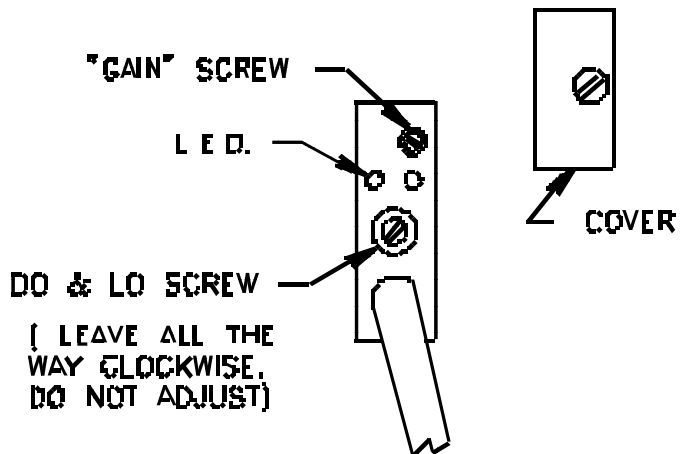

Reflective Tape Maintenance

Use a soft cloth for cleaning.
Do not use chemicals or abrasives to clean it.
Avoid any contact with oils and liquids.
Do not touch the tape with bare fingers.
If tape is dirty or opaque, the eye may not function correctly.

1335M Folder Spacer Reference Chart

QUANTITY	ASBLY#	DESC.	PREFLANGED, OFFSETTABLE, 6"								PREFLANGED, OFFSETTABLE, 9"								CONTINENTAL BORDER, 18"								DWG#
			1/8	3/16	1/4	5/16	3/8	7/16	1/2	9/16	5/8	11/16	3/4	1/8	3/16	1/4	5/16	3/8	7/16	1/2	9/16	5/8	11/16	3/4			
1	A-2216D40	L. GUIDE,1/8,KEYED,ALU	2																						298720C		
2	A-2216D32	L. GUIDE, 3/16,KEYED,ALU																							298600B		
3	A-2216D33	L. GUIDE, 1/4,KEYED,ALU																							298706B		
4	A-2216D34	L. GUIDE,5/16KEYED,ALU																							298785A		
5	A-2216D35	L. GUIDE,3/8,KEYED,ALU																							298707B		
6	A-2216D37	L. GUIDE,7/16,KEYED,ALU																							298863B		
7	A-2216D38	L. GUIDE,1/2,KEYED,ALU																							298864B		
8	A-2216D39	L. GUIDE,9/16,KEYED,ALU																							298719C		
9	A-2216D59	L. GUIDE,5/8,KEYED,ALU																							298831C		
10	A-2216D60	L. GUIDE,11/16,KEYED,ALU																							298832C		
11	A-2216D61	L. GUIDE,3/4,KEYED,ALU																							298833C		
1	A-2216D58	R. GUIDE,1/16,KEYED,THDED	2																						298724C		
2	A-2216D51	R. GUIDE,1/8,KEYED,THDED																							298602B		
3	A-2216D52	R. GUIDE,3/16,KEYED,THDED																							298747C		
4	A-2216D53	R. GUIDE, 1/4,KEYED, THDED																							298820A		
5	A-2216D54	R. GUIDE,5/16,KEYED,ALU																							298710B		
6	A-2216D55	R. GUIDE,3/8,KEYED,ALU																							298721C		
7	A-2216D56	R. GUIDE,7/16,KEYED,ALU																							298722C		
8	A-2216D57	R. GUIDE,1/2,KEYED,ALU																							298723C		
9	A-2216D62	R. GUIDE,9/16,KEYED,ALU																							298834C		
10	A-2216D63	R. GUIDE,5/8,KEYED,ALU																							298835C		
11	A-2216D64	R. GUIDE,11/16,KEYED,ALU																							298836C		
1	A-2216G14	SPACER,1/16(Ø HOLE)																							298759A		
2	A-2216G24	SPACER,1/8(Ø HOLE)	2																						298767A		
3	A-2216G32	SPACER,3/16(Ø HOLE)																							298716C		
4	A-2216G33	SPACER,1/4(Ø HOLE)																							298717C		
5	A-2216G29	SPACER,5/16(Ø HOLE)																							298808A		
6	A-2216G21	SPACER,3/8(Ø HOLE)																							298764A		
7	A-2216G30	SPACER,7/16(Ø HOLE)																							298809A		
8	A-2216G31	SPACER,1/2(Ø HOLE)																							298810A		
9	A-2216G34	SPACER,9/16(Ø HOLE)																							298719C		
10	A-2216G41	SPACER,5/8(Ø HOLE)																							298837C		
11	A-2216G42	SPACER,11/16(Ø HOLE)																							298838C		
12	A-2216G43	SPACER,3/4(Ø HOLE)																							298839C		
SSBC98024		SCREW, 10-32 X 3/8																									
SSBC98032		SCREW, 10-32 X 1/2																									
SSBC98040		SCREW, 10-32 X 5/8	4	4																							
SSBC98048		SCREW, 10-32 X 3/4			4	4																					
SSBC98056		SCREW, 10-32 X 7/8					4	4																			
SSBC98064		SCREW, 10-32 X 1							4	4																	
SSBC98072		SCREW, 10-32 X 1-1/8									4	4															
SSBC98096		SCREW, 10-32 X 1-1/2											4	4													

1335E Parameter Settings

PARAMETER	JUKI/CONSEW CHAINSTITCH	1335E PARAMETER DESCRIPTION
Do this first	****	Perform a master reset before programming, see below
290	5	Mode (Lockstitch) of operation. MUST SET THIS PARAMETER FIRST!
111	400	Maximum speed when "129" is 0, 1, or 2.
153	--	Braking power at machine stand still
161	1	Motor rotation, 1=CCW
180	--	Degrees reverse run goes to get to needle up
181	--	Delay till reverse run starts after trim
182	0	Enable reverse run after trim to get to "true" needle up
202	50	Sew delay after foot lift off
219	--	Braking power at stop
250	--	Thread trimmer activation angle
270	1	External handwheel sensor configuration. (Position 2)
271	180	Ref angle for Position 1 (Trim) from Position 2
272	100	Drive ratio between motor pulley and handwheel pulley. If handwheel pulley is smaller than motor pulley, increase this value to slow down sewing head until measured speed matches speed set with parameter 111. (For Yamato and Pegasus, setting should be 100; for Rimoldi, setting should be 124)
Front panel LED's:		
LED 1: Off		Programming Instructions: 1. Power on holding down the "P" button till "COD" is displayed. 2. Press ">>" once and enter the number "311" 3. Press "E" once and "2.0.0." is displayed this is a parameter 4. Proceed to the parameter to be changed and press "E". 5. The value now shows in the screen, adjust to desired value. 6. Press "E" to enter value and continue with parameter setting. 7. Repeat for other parameters, press "P" once when complete. 8. Run sewing head to save parameters before powering down
LED 2: Off		
LED 3: Off		
LED 4: Off		
LED 5: Off		
LED 6: Off.		
LED 7: ON, Stop at needle down.		
LED 8: OFF, Stop at needle up.		
To Perform Master Reset of Parameters: 1. Power on holding down the "P" button till "COD" is displayed. 2. Press ">>" once and enter the number "591" 3. Press "E" twice and "093" is displayed. 4. Press "+" once, "094" is displayed. 5. Press "P" to exit programming mode with all default values.		

Spare Parts Kit

Part Number	Description	Qty
1278-7055B	Proxy Switch	1
1335M-2002E	Ruffler Blade	1
5S5-31	Looper	1
61-04-01/B3	Screw	1
EEFE-RR2	Reflective Tape	12'
FFSM312LV	Electric Eye	1
GG150XL075	Gear Belt	1
GG180XL037	Gear Belt	1
GR1999	Needle Guard	1
GR2000	Needle Guard	1
GS071	Screw	1
SNTVX7X140	Needle	100

Assembly Drawings & Parts Lists

The materials contained herein are confidential and proprietary information of Atlanta Attachment Company. In addition to any confidentiality and non-disclosure obligations that currently exist between you and Atlanta Attachment Company, your use of these materials serves as an acknowledgment of the

confidential and proprietary nature of these materials and your duty not to make any unauthorized use or disclosure of these materials.



Atlanta
PARTS DEPOT

One-Stop Shopping
For Expendable Replacement Parts for AAC & Other Bedding Equipment Suppliers
Toll Free: **1-866-885-5100**
www.atlantapartsdepot.com • sales@atlantapartsdepot.com

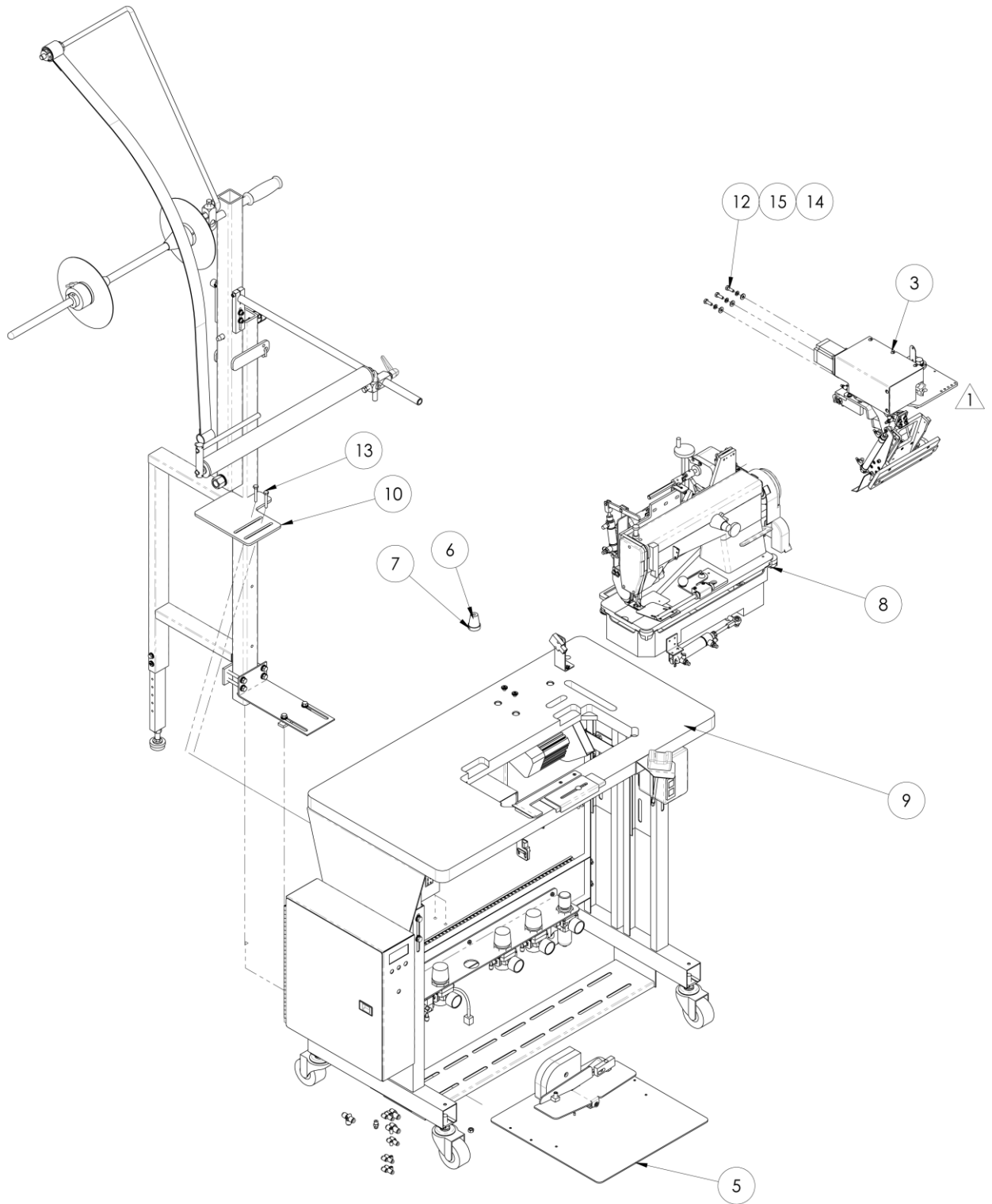

11335E Manual Ruffler

AAC Drawing Number 9000013 Rev5

ITEM NO.	QTY	PART NUMBER	DESCRIPTION
1	AR	1335E-PD	PNEUMATIC DIAGRAM
2	AR	1335E-WD	WIRING DIAGRAM
3	1	1335M-2000A	RUFFLER ASSY- 1335E
NS	1	1335M-2002E	RUFFLER BLADE
5	1	4059-FP301D	FOOT PEDAL ASSY,EFKA
6	1	51295A	ISOLATOR, MACHINE MOUNT
7	1	1335704	WASHER,3/8L,1.25OD
8	1	1335710	SEWING HEAD ASSEMBLY
9	1	1335922	STAND & MOTOR ASSY 1335E
10	1	1335930	ROLLHOLDER ASSY,OVERHEAD
11	2	NNH3/8-16	5/16-18 HEX NUT
12	3	SSHCO1048	1/4-20 X 3/4 HEX HEAD
13	2	SSHCO1112	1/4-20 X 1-3/4 HEX HEAD
14	3	WWFS1/4	WASHER FLAT, 1/4
15	3	WWL1/4	1/4 LW
16	2	WWL1/4	WASHER,LOCK,1/4
17	2	WWFS1/4	WASHER,FLAT,SAE,1/4

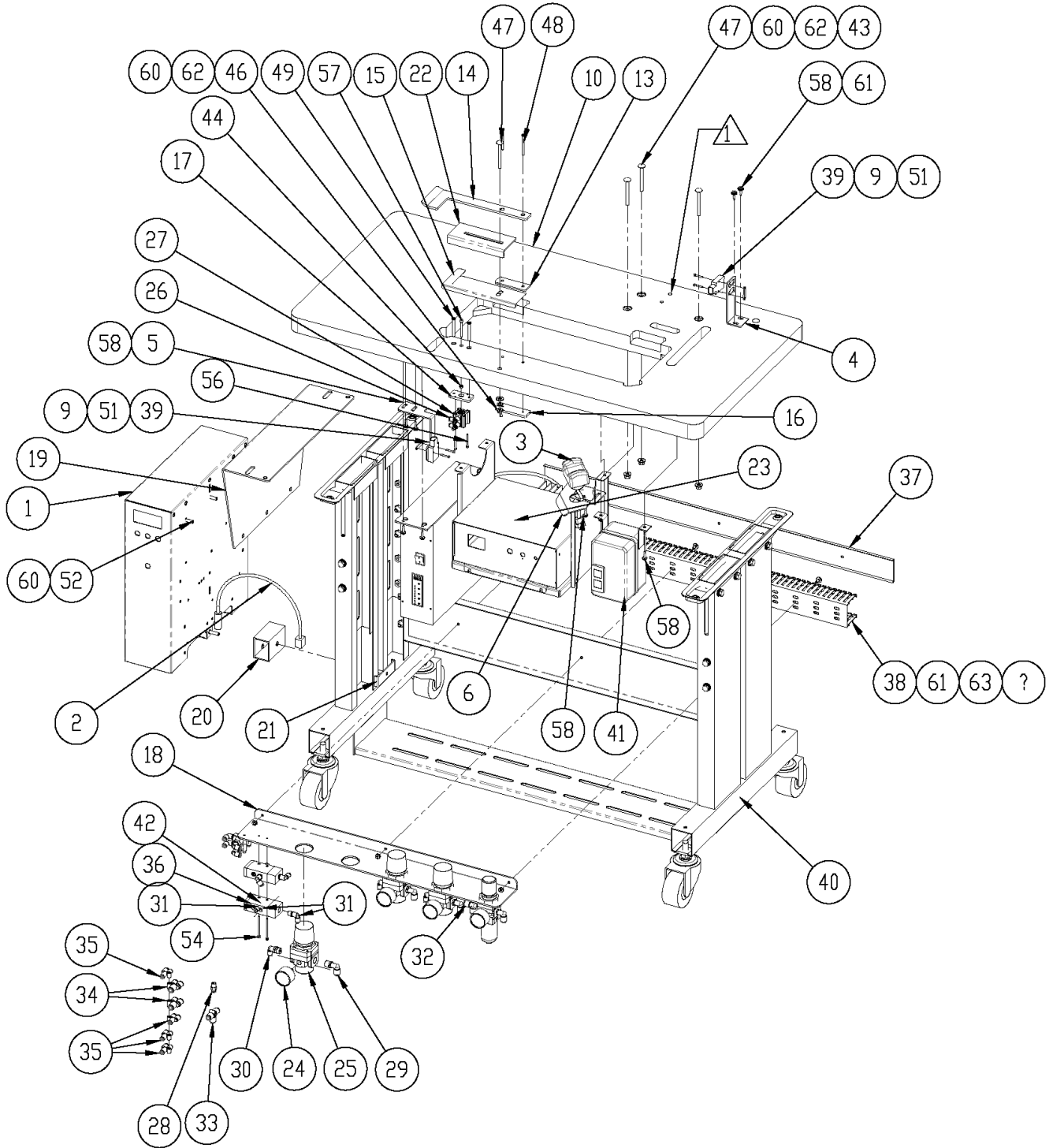

1335922 Stand & Motor Assembly

AAC Drawing Number 1335922 Rev 8

ITEM	QTY	PART NUMBER	DESCRIPTION	ITEM	QTY	PART NUMBER	DESCRIPTION
1	1	1335E-500	CONTROL BOX ASSY	34	1	EEDF2X2	DUCT,WIRE,2X2, MOD
2	1	0211-702A	CABLE,POS. SENSOR,6'	35	2	FFSM312LVQ	EYE,ELECTRIC,10-30VDC
3	1	1278-6602A	TOUCH SWITCH ASSEMBLY	36	1	K-CB600	MOTOR STARTER,ELEC
4	1	1278-6689B	BRACKET, EYE MOUNT	37	1	MM4554K11	PLUG, 1/8" PIPE
5	1	1278-6689D	TABLE EYE MOUNT	38	3	NNH1/4-20	NUT,HEX,1/4-20
6	1	1278-6718A	BRKT,OPTO TOUCH SWITCH	39	1	NNHM4X0.7	NUT,HEX,M4-0.7
NS	AR	1335E-PD	PNEUMATIC DIAGRAM	40	3	NNK10-32	KEP NUT, 10-32
NS	AR	1335E-WD	WIRING DIAGRAM	41	1	NNW1/4-20	NUT, WING, 1/4-20
9	2	1975-412A	PLATE,NUT,4-40,,95CTC	42	4	SSBK01160	BOLT, CRGE, 1/4-20X2-1/2
10	1	4048-326S	TABLE TOP,326S CONSEW	43	2	SSFS90128	#8-32 X 3/4 FLAT SLOT
11	1	4080-4508B	CABLE,STEP MOTOR,4 AMP,7'	44	2	SSFS98112	#8-32 X 3/4 FLAT SLOT
12	1	1335274	WASHER PLATE - PANEL TENS	45	4	SSPS70048	4-40 X 3/4 PAN HD SLOTTED
13	1	1335275	TOP PLATE- PANEL TENSION	46	2	SSSC80128	6-32 X 2 SOC CAP SC
14	1	1335278	PANEL TENSION FINGER	47	3	SSSC98032	10-32X1/2, SOC CAP
15	1	1335280	NUT PLATE - PANEL TENSION	48	2	SSSCM3X30	SCREW,SOC CAP,M3 X 30MM
16	1	1335281	NUT PLATE - PANEL TENSION	49	1	SSSCM4X40	SCREW,SOC CAP,M4-0.7X40
17	1	1335716	PNEUMATIC, SHELF	50	16	SSZH#10048	SCREW,SHT.METAL HEX 10
18	1	1335786	SPACER HOLDER	51	2	TTIW1/4-20	THREADED INSERT, WOOD.1/4-20
19	1	1335872	EDGE GUIDE	52	8	WWFS1/4	WASHER,FLAT,SAE,1/4
20	1	1335924	Stepper Box Assembly	53	5	WWFS10	WASHER, FLAT, #10, SAE
21	1	AA198-503	0-30PSI AIR GAGE 1/8NPT	54	5	WWL1/4	WASHER,LOCK, 1/4
22	1	AA198-RP3	REGULATOR,PRECISION AIR	55	1	1335784	BRKT,ANGLE,CONTROL BOX
23	1	AACNCQ2B16-10D	COMPACT, 16MM BORE, 10MM	56	1	1335785	SPACER BLOCK
24	1	AAQMC-5-8	QU. MALE CONN 5/32X1/8	57	1	SSHC01160	1/4-20 X 2-1/2 HHCS
25	1	AAQME-4-4	ELBOW, MALE,Q, 1/4 TUBE, 1/4 NPT	58	3	WWL10	WASHER,LOCK,#10
26	1	AAQME-5-4	ELBOW, QUICK MALE, 5/32 X 1/4 NPT	59	1	SSSC01040	1/4-20 X 5/8" SOC CAP SC
27	3	AAQME-5-8	QUICK MALE ELBOW	60	3	SSSC01032	1/4-20X1/2 SOC CAP
28	1	AAQMT-4-4	T, MALE1/4X1/4NPT	61	2	AA198RA510	FL CONT,5/32X10-32
29	1	AAQUT-4-4	QUICK UNION T 1/4X1/4	62	1	K-4D	35.5 LEG CENTERS
30	2	AAQUY-4-4	Y UNION, 1/4X1/4	63	1	WWF1/4	WASHER, FLAT, 1/4", COM
31	4	AAQUY-5-5	QUICK UNION Y, 5/32	64	1	4059-DC1500	EFKA DC1500/AB220A
32	1	AAV125B	PILOT VALVE	65	1	4059-DC1500	EFKA CONTROLLER BOX
33	1	EEDC2X2	COVER,WIRE DUCT				

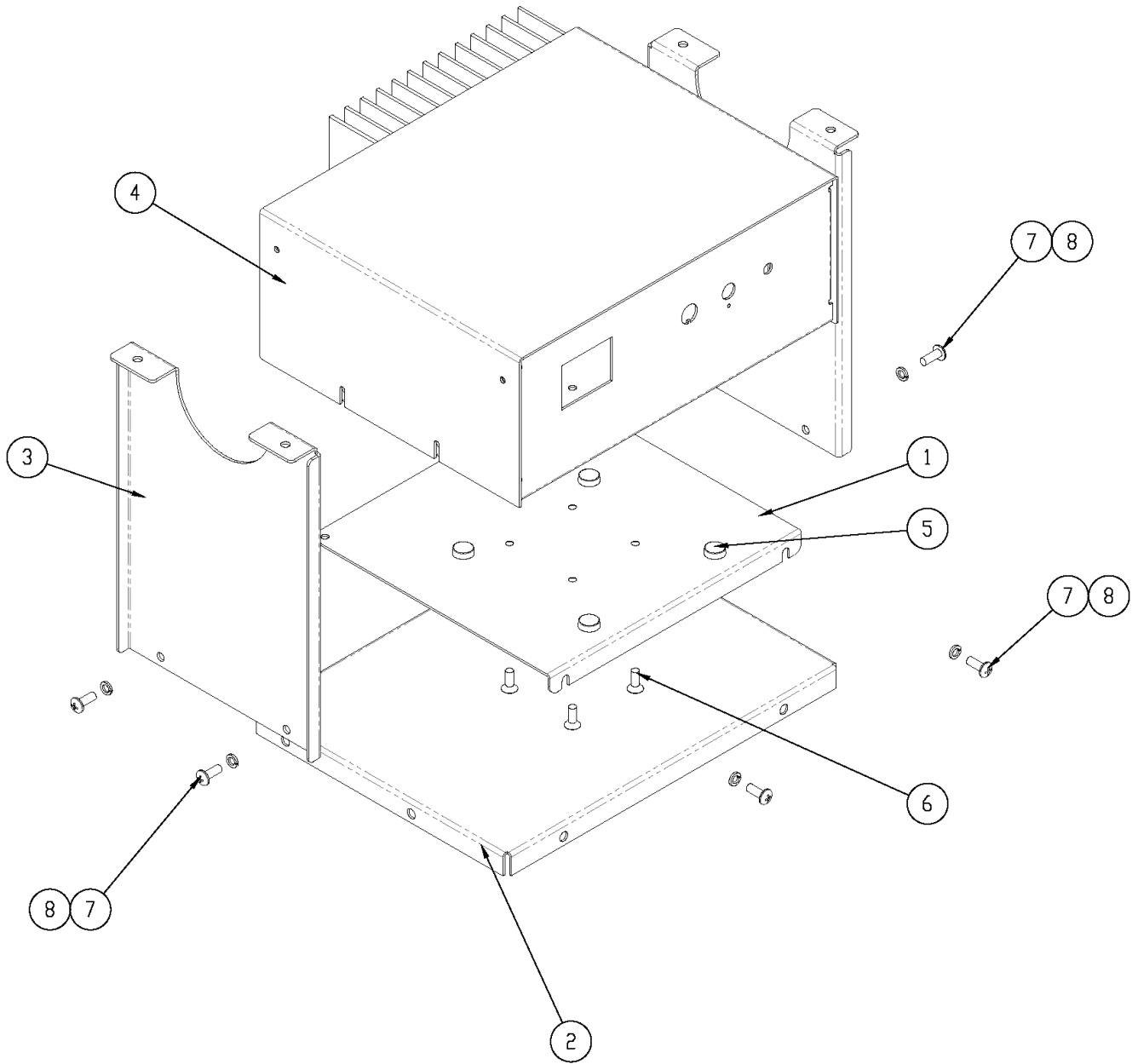

1335924 Stepper Box Assembly

AAC Drawing Number 1335924 Rev1

NO.	QTY	PART#	DESCRIPTION
1	1	1335M-9010	BRKT, STEPPER BOX BASE
2	1	1335M-9011	BOX , SHELF MOTOR
3	2	1335916	MNT, CTRL BOX
4	1	AP-28-800Y1A	BOX,STEPPER,H.S. (X5),2A
5	4	MMSLD-ECH	1/2" DIA RUBBER BUMPER
6	4	SSFC98032	10-32 X 1/2 FLAT ALLEN CAP
7	6	SSPP98032	10-32 X 1/2 PAN PHIL
8	6	WWL10	WASHER,LOCK,#10

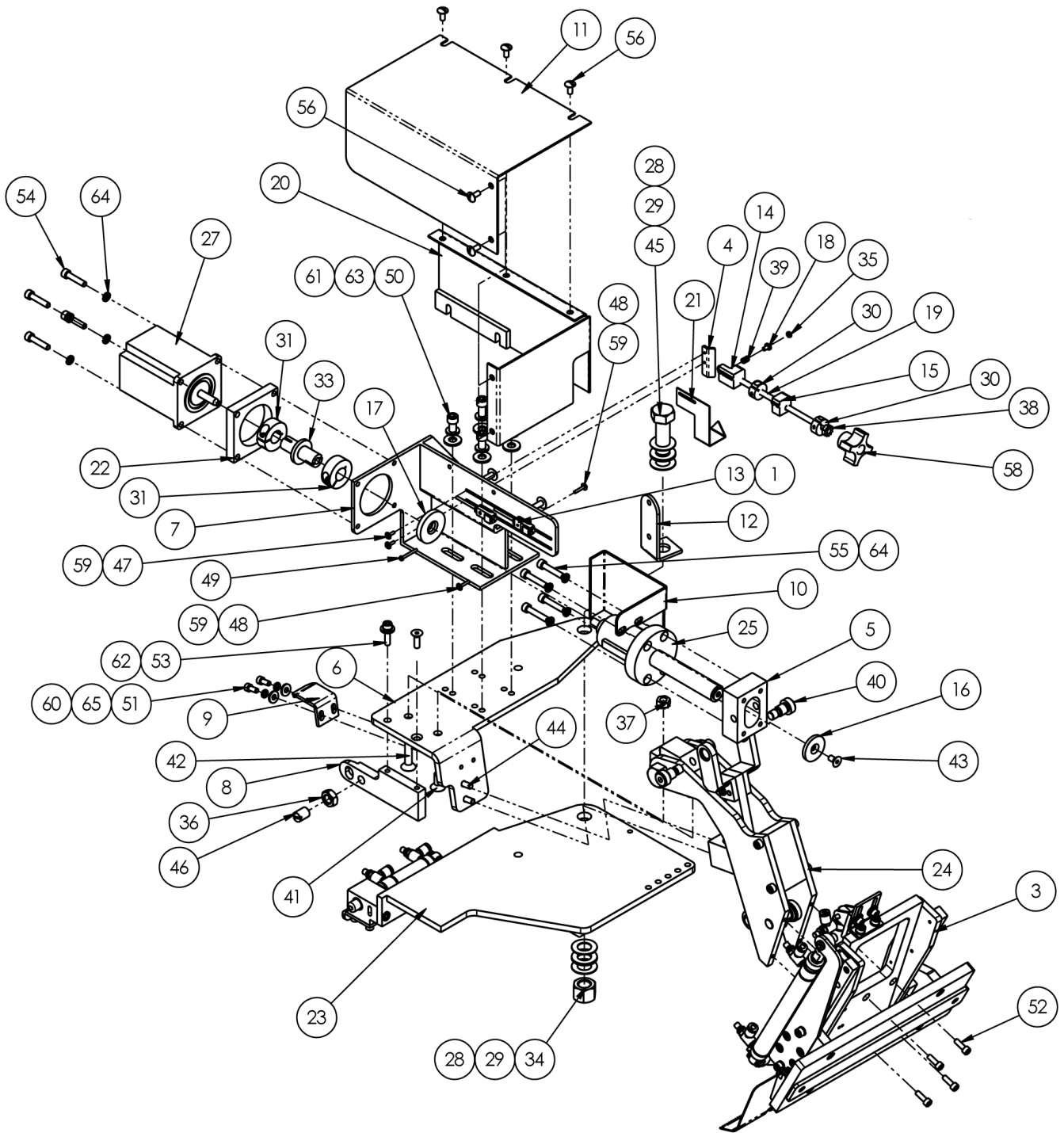

1335M-2000A Ruffler Assembly

AAC Drawing Number 9000004 Rev3

Page 34

NO.	QTY	PART #	DESCRIPTION	NO.	QTY	PART #	DESCRIPTION
1	2	1278-7055D	PROX SWITCH W/PLUG,12"	34	1	NNE1/2-13	ELASTIC LOCK NUT
NS	AR	1325-4126	TEFLON TAPE, 1"	35	1	NNH2-56	#2-56 HEX NUT
3	1	1335332	RUFFLER CYL LIFT ASSY	36	1	NNJ3/8-16	3/8-16 HEX JAM NUT
4	1	1335M-001	BRACKET, STOP, PROX SWITC	37	1	NNK1/4-20	KEP NUT, 1/4-20
5	1	1335M-2006	TRUNION BLOCK	38	1	NNK10-32	KEP NUT, 10-32
6	1	1335M-2008	PIVOT PLATE	39	1	RRLC026B1	SPRING,COMP .026X.18X.25
7	1	1335M-2016	MTG BRKT WELDT	40	2	SSAS024024M	3/8 X 3/4 X 5/16-18
8	1	1335M-2019	LOCKING LEVELR	41	1	SSFC01040	1/4-20 X 5/8 FLAT ALLEN
9	1	1335M-2020	HLD DWN BRKT	42	1	SSFC01096	1/4-20 X 1-1/2 FLAT ALLEN
10	1	1335M-2021	VANE, SWITCH ACTUATING	43	1	SSFC98024	#10-32 X 3/8 FLAT ALLEN
11	1	1335M-2030	MOTOR COVER, CLEAR	44	3	SSFC98040	#10-32 X 5/8 FLAT ALLEN
12	1	1335M-2031	PIVOT BRKT AIR LINE	45	1	SSHC45096	1/2-13 X 1 1/2 L HHCS
13	1	1335M-2034	NUT PLATE #2-56	46	1	SSMB58N	PLUNGER,BALL,3/8-16X5/8L
14	1	1335M-2035	ADJUSTMENT NUT	47	2	SSPS50020	#2-56 X 5/16 PAN HD SLOT
15	1	1335M-2036	SUPPORT BLOCK	48	2	SSPS50032	#2-56 X 1/2 PAN HD SLOT
16	1	1335M-2037	STOP WASHER	49	1	SSPS50048	#2-56 X 3/4 PAN HD SLOT
17	1	1335M-2038	STOP WASHER	50	4	SSSC01032	1/4-20 X 1/2 SOC CAP
18	1	1335M-2039	NUT,SPRING RETAINER	51	2	SSSC90024	#8-32 X 3/8 SOC CAP
19	1	1335M-2040	ADJUSTMENT SCREW	52	4	SSSC90032	#8-32 X 1/2 SOC CAP
20	1	1335M-2042	COVER	53	1	SSSC98048	#10-32 X 3/4 SOC CAP
21	1	1335M-2047	POINTER	54	4	SSSC98056	#10-32 X 7/8 SOC CAP
22	1	1335M-2049	SPACER, MOTOR, 3/8	55	4	SSSC98064	#10-32 X 1 SOC CAP
23	1	1335M-2200	PLATE, NUT, 8-32 @.43 CTC	56	5	SSTS90024	#8-32 X 3/8 TRUSS HD
24	1	1335M-2300B	PIVOT ASSY	57	2	SSTS98040	#10-32 X 5/8 TRUSS HD
25	1	1335M-2400	BALL SCREW AND NUT	58	1	TTCL1APPK1	PLASTICK KNOB, #10-32
26	1	AA198-7006	O RING, 1/8 ID, 1/4 OD	59	4	WWF2	WASHER, FLAT #2
27	1	AP-22E-103	STEP MOTOR,MODIFIED	60	2	WWF8	WASHER, FLAT #8
28	2	BBNTA815	BEARING,THRUST,1/2BORE	61	4	WWFS1/4	WASHER FLAT, 1/4
29	4	BBTRA815	WASHER,THRUST,STEEL 1/2	62	1	WWFS10	WASHER, FLAT #10
30	2	CCCL10T	CLAMP COLLAR TRD, 10-32	63	4	WWL1/4	1/4 LW
31	2	CCCL8F	CLAMP COLLAR- 1/2	64	9	WWL10	#10 LW
32	20"	MM130-4126	LABEL, SCALE, METRIC	65	2	WWL8	#8 LW
33	1	MM8FM	JOINT,UNIVERSAL,MOD				

Page 48

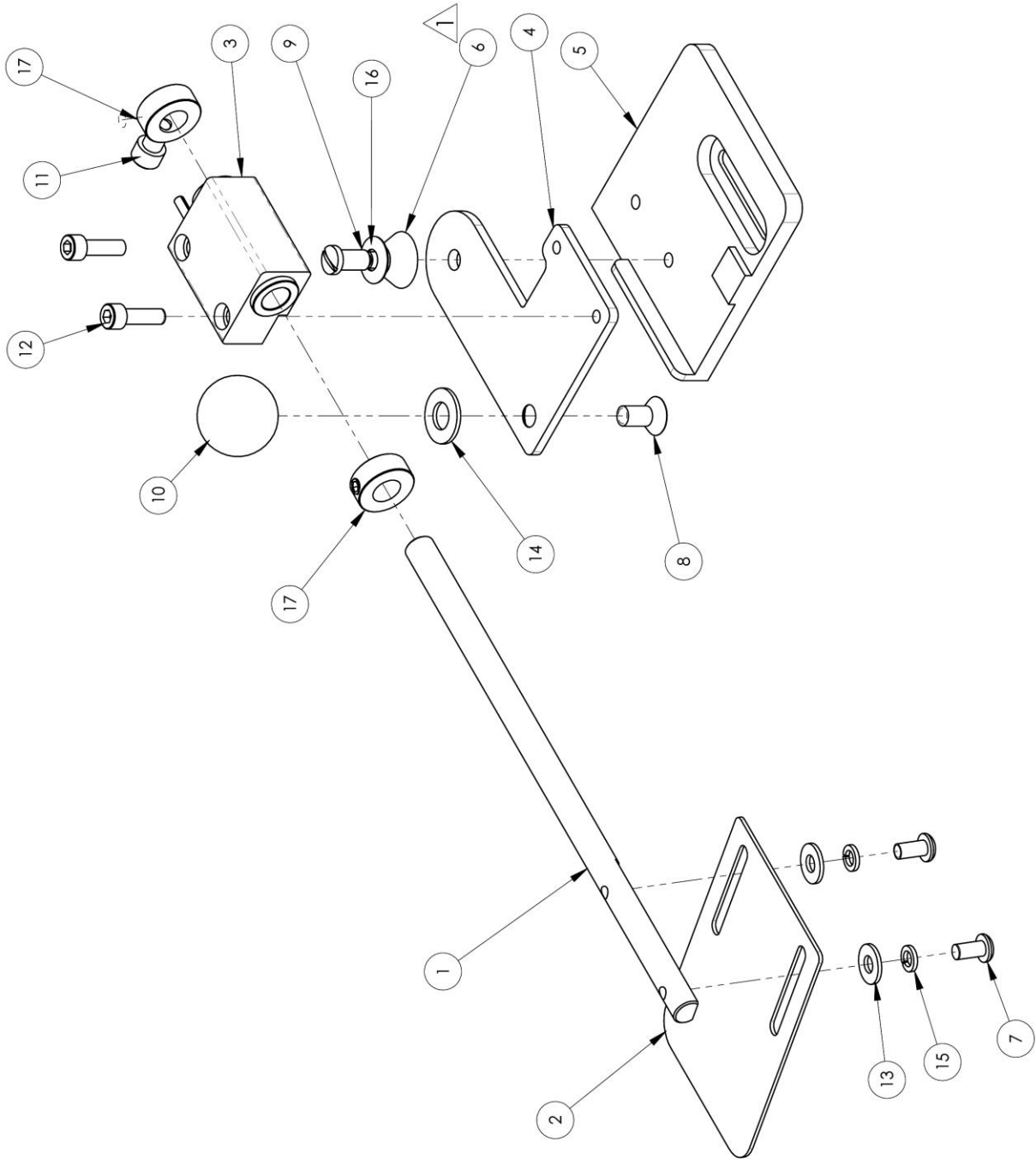

1335183 Stripper Blade Assembly

AAC Drawing Number 1335183 Rev2

ITEM NO.	QTY	PART NUMBER	DESCRIPTION
1	1	1335154	PIVOT ROD, STRIP BLADE
2	1	1335475	STRIPPER BLADE-1804P
3	1	1335624	BLOCK, MOUNTING
4	1	1335627	MOUNT ARM, STRIPPER BLADE
5	1	1335M-5001	PLATE, MOUNTING
6	1	RRBEEHIVEH	SPRING, HEAVY BEEHIVE
7	2	SSBC98024	10-32 X 3/8 BUTTON CAP SC
8	1	SSFC01032	1/4-20 X 1/2 FLAT ALN CAP
9	1	SSM200246	SCREW, SHLDR, SLT. 248X.437L
10	1	SSMBK13	KNOB, BLACK PLASTIC
11	1	SSSC01024	1/4-20 X 3/8 SOC CAP SC
12	2	SSSC98040	10-32 X 5/8 SOC CAP
13	2	WWFS10	WASHER, FLAT, #10, SAE
14	1	WWFS5/16	WASHER, FLAT, SAE, 5/16
15	2	WWL10	WASHER, LOCK, #10
16	1	WWS307-1	WASHER, SPRING, BELVEL
17	2	CCSC6F3/8	COLLAR, SET 3/8

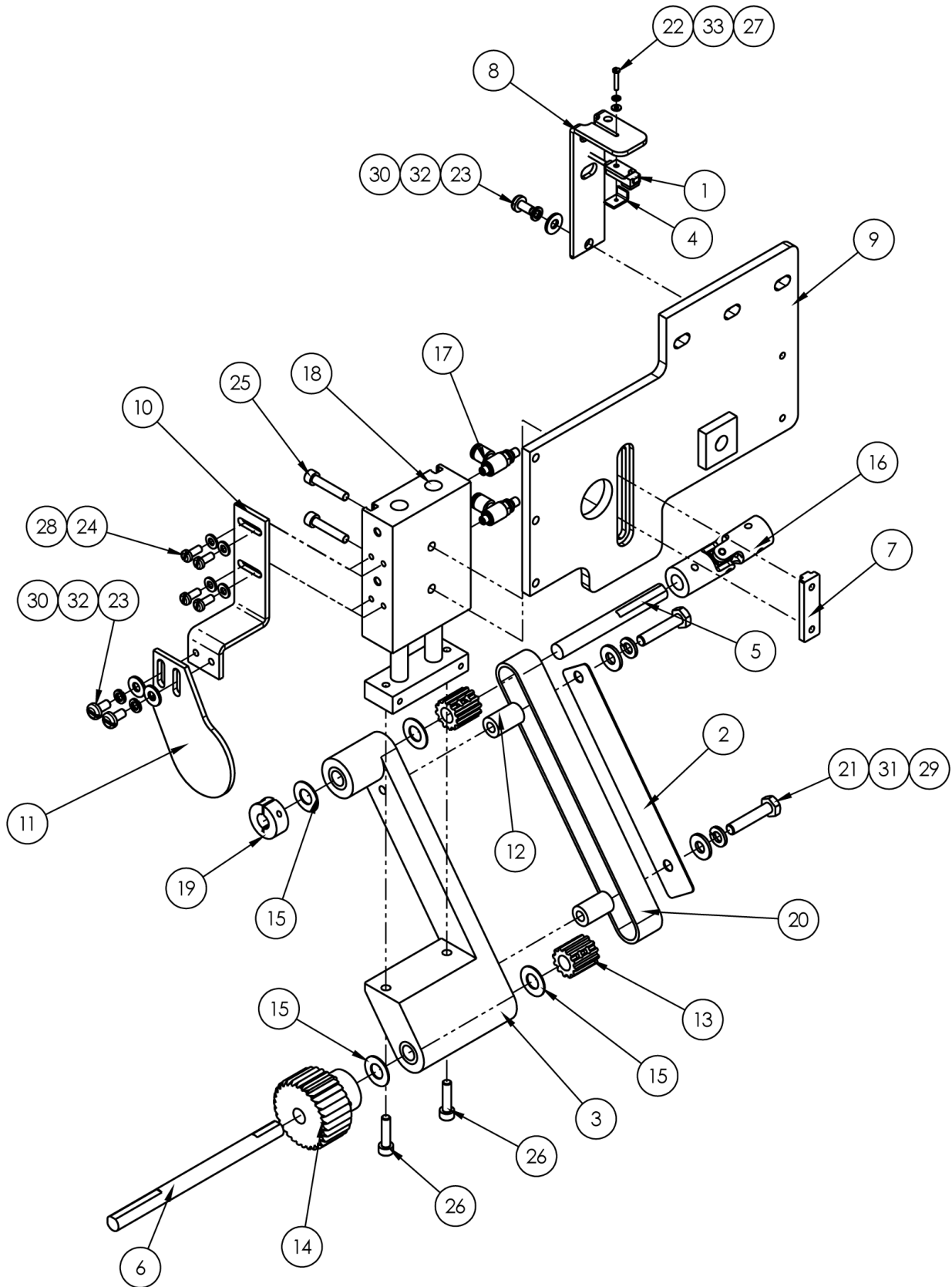

1335184 Puller Assembly

AAC Drawing Number 1335184 Rev2

NO.	QTY	PART #	DESCRIPTION
1	1	1278-7055D	PROX SWITCH W/PLUG,12"
2	1	1335185	COVER, DRIVE BELT
3	1	1335927	YOKE, PULLER
4	1	1335M-2034	PLATE, NUT #2-56
5	1	1335M-3002	SHAFT,FLAT,60C,.375OD
6	1	1335M-3003	SHAFT,FLAT,60C,.375OD
7	1	1335M-3007	T-NUT, 10-32
8	1	1335M-3008	MTG. BRKT. SENSOR
9	1	1335M-3010	BRKT, CYLINDER MOUNT
10	1	1335M-312	BRACKET,GUARD MOUNT
11	1	1335M-313	PLATE, PLASTIC, GUARD
12	2	1535-241	SPACER, TRANSFER
13	2	350196	GEAR PULLEY, .376 ID, .74
14	1	3514-3C	ROLLER, FLUTED, 30T, 1.75
15	4	3517	WASHER,THRUST,BRONZE
16	1	3524-06A	U-JOINT,MODIFIED
17	2	AA198RA510	FLOW CONTROL,5/32X10-32
18	1	AACXSM2020	CYLINDER,AIR,DUAL ROD
19	1	CCCL6F	CLAMP COLLAR- 3/8
20	1	GG150XL075	BELT,GEAR,1/5P,75T,3/4W
21	2	SSHCO1080	1/4-20 X 1-1/4 HHCS
22	1	SSPS50032	SCREW,2-56 x 1/2
23	3	SSPS98024	10-32X3/8 PAN HD SLOT
24	4	SSPSM4X10	M4-0.70X10
25	2	SSSC98064	10-32 X 1 SOC CAP
26	2	SSSCM5X20	M5-0.8 X 20 SOC CAP
27	1	WWF2	WASHER, FLAT, #2
28	4	WWFM4.3	WASHER, FLAT, M4
29	2	WWFS1/4	WASHER,FLAT,SAE,1/4
30	3	WWFS10	WASHER, FLAT, #10, SAE
31	2	WWL1/4	WASHER,LOCK,1/4
32	3	WWL10	WASHER,LOCK,#10
33	1	WWSI2	WASHER,INTERNAL TOOTH,2

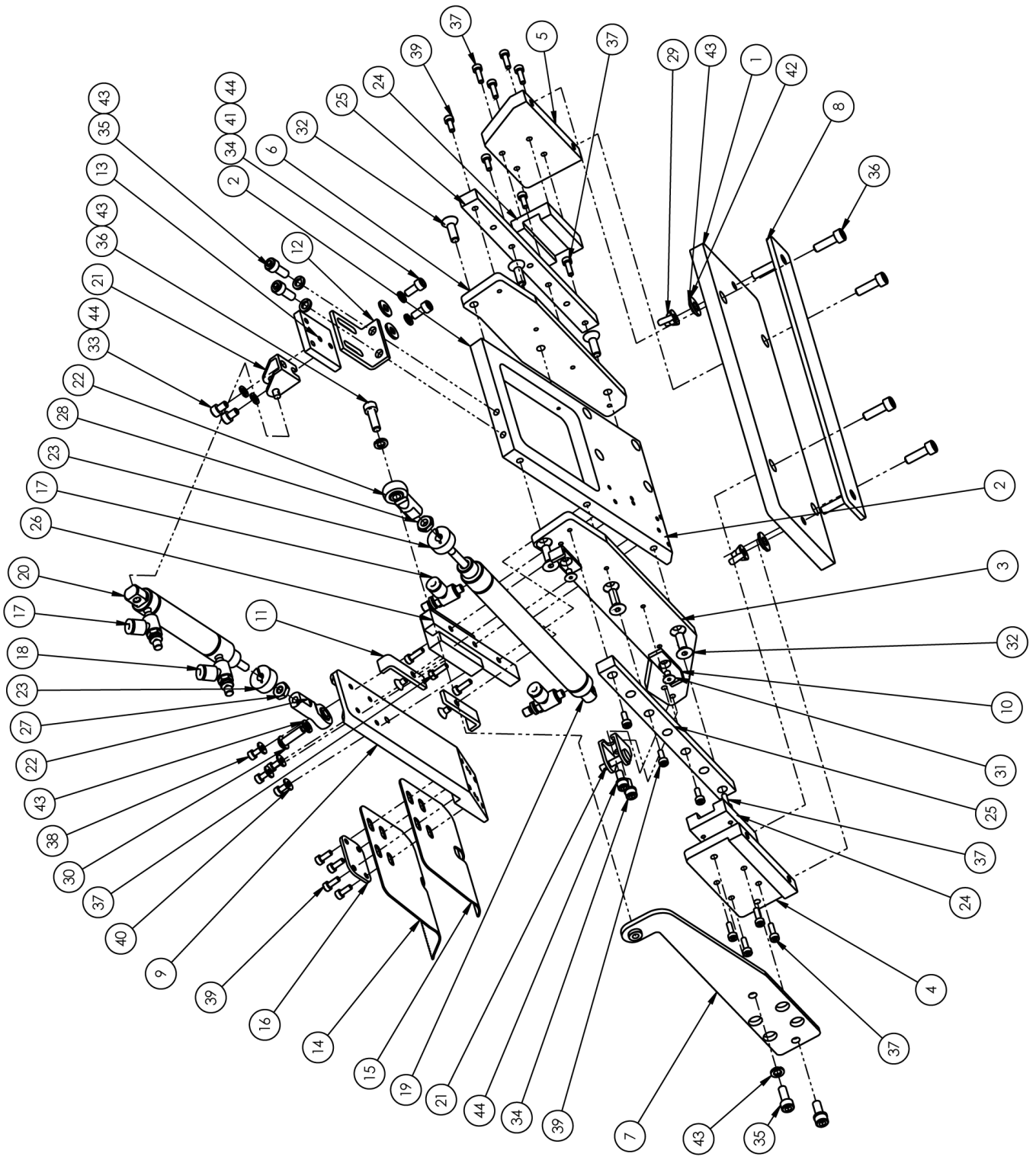

1335332 Ruffler Cylinder Lift Assembly

AAC Drawing Number 1335332 Rev8

NO.	QTY	PART #	DESCRIPTION
1	1	1335223	BASE MTG PLT, FOLDER
2	1	1335224	BASE MTG PLATE
3	1	1335226	MTG PLT LH- RAIL
4	1	1335227	SUPPORT-SLIDE, LH SIDE
5	1	1335228	SUPPORT, RH
6	1	1335229	MTG PLT RH- RAIL
7	1	1335230	FOLDER SLIDE ARM
8	1	1335235	STUD PLATE-YAMATO1804
9	1	1335335	MTG PLT- HEAVY DUTY
10	2	1335338	BRG STOP
11	2	1335775	BEARING STOP, LONG
12	1	1335776	CYL. MOUNTING ANGLE
13	1	1335777	CYL. MOUNTING PLATE
14	1	1335M-2002E	BLADE, RUFFLER, 2.25 X 12
15	1	1335M-2002F	BLADE, RUFFLER, 2.25 X 12
16	1	1335M-5004	PLATE, WASHER, 136DIA@4PL
17	3	AA198RA510	FLOW CONTROL,5/32X10-32
18	1	AA198RR510	REV FL CONT,5/32X10-32
19	1	AAC024DXP	CYL,BIMBA,9/16 B,4 S
20	1	AAC8DP-1.5	CYL, AIR, DA, 9/16B, 2S
21	2	AAFBP-8C	BRKT,PIVOT,5/32 BORE
22	2	BBAW-3Z	BRG,ROD END,F, 10-32
23	2	CCCL3F	CLAMP COLLAR- 3/16
24	3	MMGN12HZ0HN	MGN12H BEARING BLOCK
25	2	MMGNR12R0165HN	165MM RAIL - MGN12H BLK
26	1	MMGNR12R090HN	12MM X 90MM RAIL
27	1	NNH10-32	#10-32 HEX NUT
28	1	NNJ10-32	NUT,JAM,THIN #10-32
29	2	NNW10-32	#10-32 WING NUT
30	1	SSBC98040	#10-32 X 5/8 BUT HEAD
31	4	SSFC80016	#6-32 X 1/4 FLAT ALLEN
32	6	SSFC98040	#10-32 X 5/8 FLAT ALLEN
33	2	SSSC90016	#8-32 X 1/4 SOC CAP
34	4	SSSC90024	#8-32 X 3/8 SOC CAP
35	4	SSSC98032	#10-32 X 1/2 SOC CAP
36	5	SSSC98040	#10-32 X 5/8 SOC CAP
37	13	SSSCM3X10	M3-0.5 X 10 SOC CAP
38	4	SSSCM3X6	M3-0.5 X 6 SOC CAP
39	10	SSSCM3X8	M3-0.5 X 8 SOC CAP
40	4	WWF4	WASHER, FLAT #4
41	2	WWF8	WASHER, FLAT #8
42	2	WWFS10	WASHER, FLAT #10
43	8	WWL10	#10 LW
44	6	WWL8	#8 LW

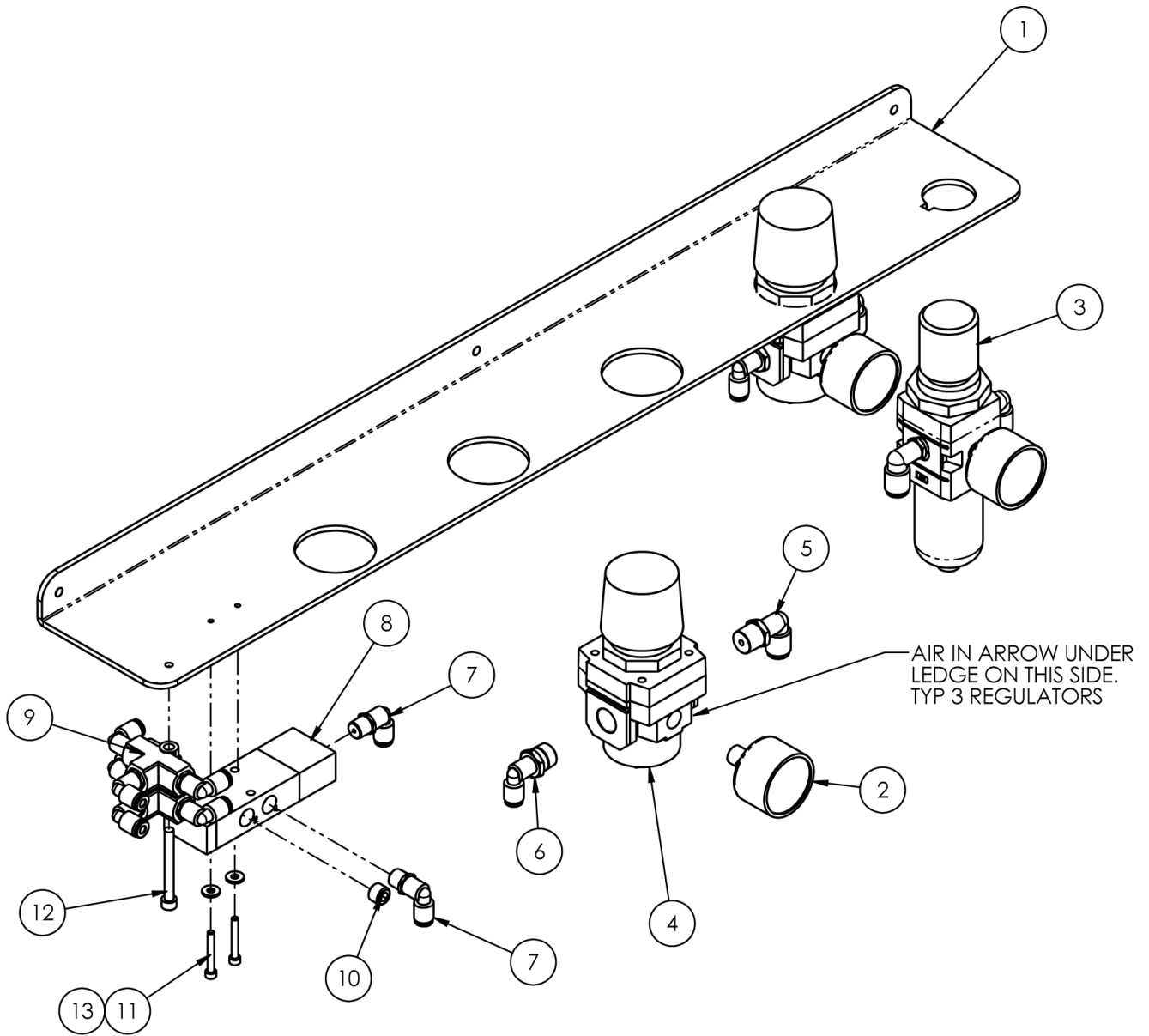

1335716 Pneumatic Shelf Assembly

AAC Drawing Number 1335716 Rev3

NO.	QTY	PART #	DESCRIPTION
1	9	AAQME-5-8	QUICK MALE ELBOW
2	2	AAVS125	SHUTTLE VALVE, 1/8" PORT
3	2	SSSC80064	#6-32 X 1 SOC CAP
4	2	WWFS6	WASHER, FLAT, #6
5	1	1335715	BRACKET, PNEUMATIC
6	1	AA198-503	0-30PSI AIR GAGE 1/8NPT
7	1	AA198-5102	REGULATOR W/GAUGE & NUT
8	1	AA198-RP3	REGULATOR, PRECISION AIR
9	2	AAQME-4-4	ELBOW, MALE, 1/4X1/4NPT
10	2	AAQME-5-4	ELBOW, MALE 5/32X1/4NPT
11	1	AAV125B	PILOT VALVE
12	1	MM4554K11	PLUG, 1/8" PIPE
13	1	SSSC98112	SCR, SOC CAP 10-32 X 1-3/4

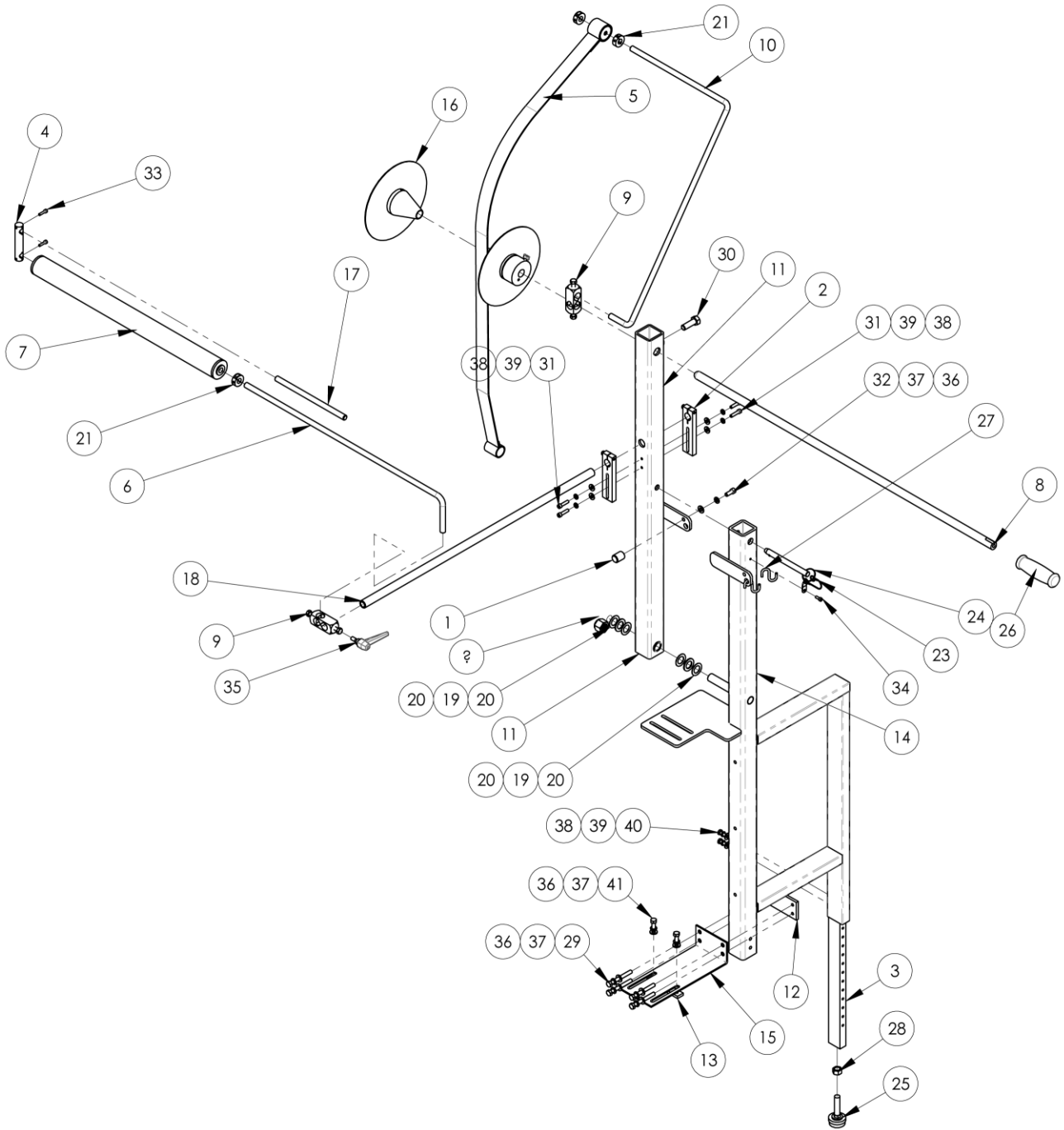

1335930 Roll Holder Assembly

AAC Drawing Number 1335930 Rev4

NO	QTY	PART #	DESCRIPTION
1	1	11200A	BUMPER 5/16-24
2	2	1325-346A	HOLDER, ROD, 3/4", SLOT
3	1	132556-273	LEG, 3/4 X 1-1/2 X 15 LG
4	1	1335-319B	ARM, 1/2" ROD CLAMP
5	1	1335-825	DRAG TENSION ASSEMBLY
6	1	1335-835A	ROD, 1/2 DIA, 90 DEG
7	1	1771-205	ROLLER, 2.0 O.D X .51 D X 23.38 L
8	1	1961-252E	ROD, ROLL, 38.0 L
9	2	28201	BLOCK, CROSS, (LARGE)
10	1	1335179	ROD, BENT, CRS, 1/2 OD
11	1	1335664	PIVOT, SWING
12	1	1335667	NUT, PLATE, 5/16-18 4X
13	1	1335794	NUT, PLATE, 5/16-18, 2@3.0
14	1	1335931	MAIN SUPPORT, UNWINDER
15	1	1335932	STABILIZER, UNWINDER, 1335E
16	2	33008708	DISC ASSY, 8"
17	1	8732-0576	ROD, STRAIGHT, SS, 1/2 X
18	1	97-1711	TUBE, 3/4 X 30 X 1/8 WALL
19	2	BBNTA1220	BEARING, THRUST, .750B
20	4	BBTRA1220	WASHER, THRUST, STEEL
21	3	CCCL8F	CLAMP COLLAR- 1/2
22	2 FT	K-3594T47	CHAIN, .190, .34W
23	1	MM30345T21	LANYARD, 6" LONG
24	1	MM98320A525	QUICK RELEASE PIN, 1/2" DIA
25	1	MMFB4444	FOOT, RUBBER
26	1	MMGP-105	GRIP HANDLE-FOAM 3/4 ID
27	2	MMS096	HOOK, S, 3/16 X 1-1/2"
28	1	NNH1/2-13	NUT, HEX, 1/2-13
29	4	SSHHC10176	5/16-18 X 2-3/4 HEX HEAD
30	1	SSHHC45096	1/2-13 X 1-1/2 HEX HEAD
31	4	SSSC01064	1/4-20 X 1 SOC CAP
32	1	SSSC20048	5/16-24 X 3/4 SOC CAP
33	2	SSSC95048	#10-24 X 3/4 SOC CAP
34	1	SSSC98032	#10-32 X 1/2 SOC CAP
35	1	TTH32425	HANDLE, THRD, 5/16-18 X 3/4
36	7	WWFS5/16	WASHER, FLAT, 5/16
37	7	WWL5/16	5/16 LW
38	6	WWFS1/4	WASHER, FLAT, SAE, 1/4
39	6	WWL1/4	WASHER, LOCK, 1/4
40	2	SSHHC01064	1/4-20 X 1 HHCS
41	2	SSHHC10064	5/16-18 X 1 HHCS
42	1	NNE.75-16	NUT, ELASTIC LOCK, 3/4-16



1335710 Sewing Head Assembly

AAC Drawing Number 1335710 Rev 6

ITEM	QTY.	PART NUMBER	DESCRIPTION
1	1	22T7-013M	PRESSER BAR SPRING, MOD.
2	1	40-576	PLATE,NUT,10-32@.75 CTC
3	1	1278-6364	DISC, TAPE MOUNTING
4	1	1335M-113	FOOT PRESSURE ASSY
5	1	1335M-3009	BRKT, FACE MOUNT
6	1	1335M-6000	FOOTLIFT ASSEMBLY
7	1	3524-06A	U-JOINT,MODIFIED
8	1	22100-019	ADAPTER, SYNCHRONIZER
9	1	1335183	STRIPPER BLADE ASY,1335MD
10	1	1335184	PULLER ASSEMBLY,326S CONS
11	1	1335700	THROAT PLATE, SCON-326S
12	1	1335701	BRACKET,L
13	1	1335702	BLT GD,1.88R
14	1	1335703	BELT GD, 326S CONSEW
NS	1	1335712	LIFTING ROD
16	1	1335717	OIL PAN, SJUKI-481U
17	1	1335911	HANDWHEEL, SCON-326S
18	1	1335921	HEX SHAFT, 3/8X4.5
19	1	1335923	ZERO-MAX MOUNT, 326S CONS
20	1	B1122552000	GASKET,FACE PLATE
21	1	GG180XL037	BELT,GEAR,1/5P,3/8W
22	1	M1191-019	FOOT, SN, LEFT EXT.
23	1	PP20XLB037M2	PULLEY 1/5P, 20T
24	1	SCON-326S	SEWING HEAD,CONSEW
25	6	SS7111810TP	SCREW,11/64-40X18MM
26	5	SSBC98032	10-32 X 1/2 BUTTON CAP SC
27	1	SSHHC20064	5/16-24 X 1 HEX CAP
28	2	SSSC98016	10-32 X 1/4 SOC CAP
29	2	SSSC98024	10-32 X 3/8 SOC CAP
30	1	WWL5/16	WASHER,LOCK, 5/16
31	2	WWL10	WASHER,LOCK,#10

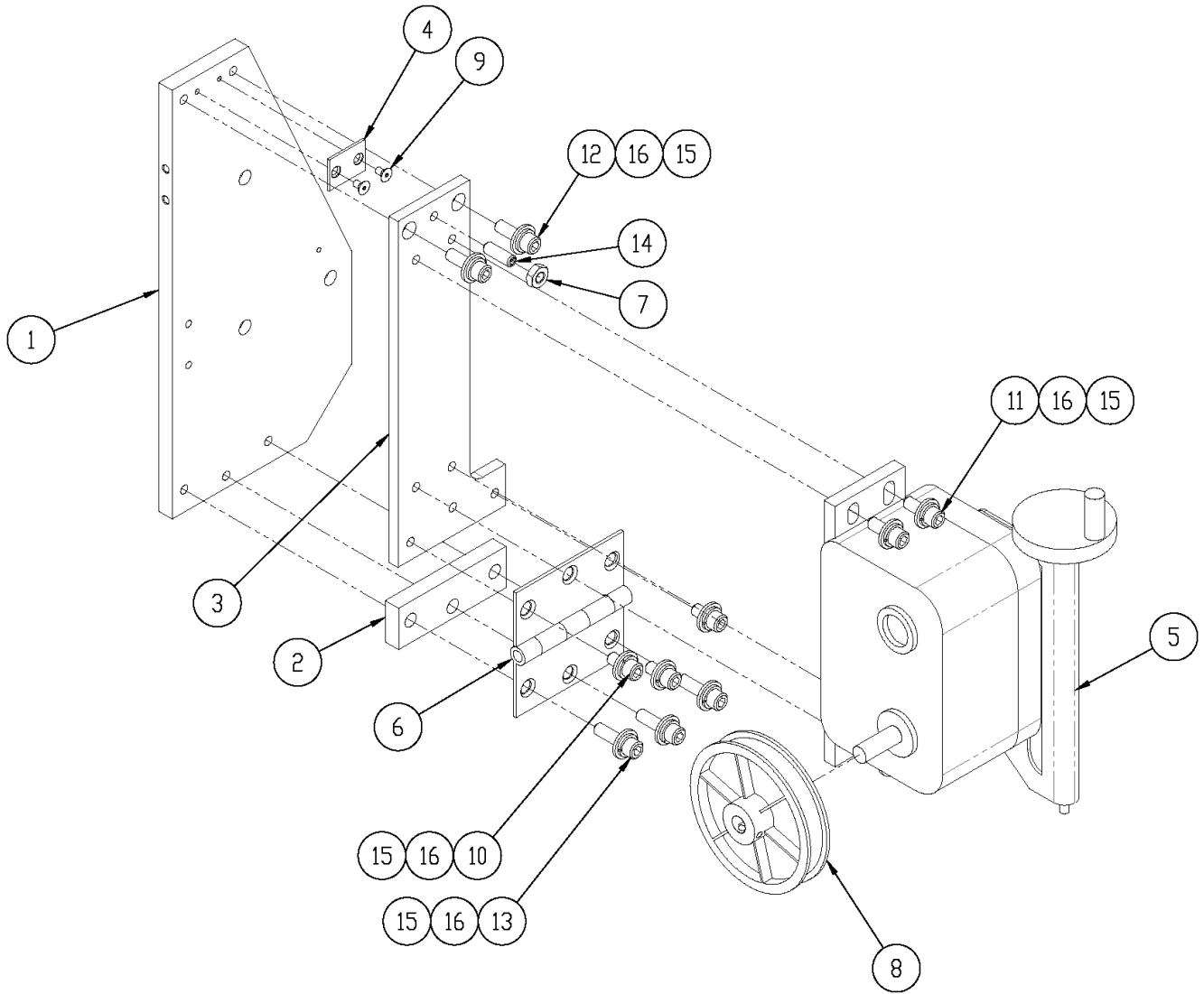

1335923 Zero-Max Mount Assembly

AAC Drawing Number 1335923 Rev2

NO.	QTY	PART#	DESCRIPTION
1	1	1335912	MOUNT, ZERO-MAX,
2	1	1335913	HINGE SPACER, 1335E
3	1	1335914	BASE, ZERO-MAX, 1335E
4	1	1335915	PRESSURE PLATE, 1335E
5	1	E2SC	Z-MAX W/SCR CNTRL,CW
6	1	MM741-3A	HINGE,3X3,STANLEY
7	1	NNJ1/4-20	NUT, HEX, JAM, 1/4-20
8	1	PP48XL037	PULLEY,GEAR,1/5P,48T,3/8B
9	2	SSFC80016	SCR,FLAT HD,CAP,6-32 X 1/4
10	3	SSSC01032	1/4-20X1/2 SOC CAP
11	4	SSSC01040	1/4-20 X 5/8" SOC CAP SC
12	2	SSSC01048	1/4-20 X 3/4" SOC CAP SC
13	3	SSSC01056	1/4-20 X 7/8 SOC CAP
14	1	SSSS01048	1/4-20 X 3/4
15	12	WWFS1/4	WASHER,FLAT,SAE,1/4
16	12	WWL1/4	WASHER,LOCK,1/4

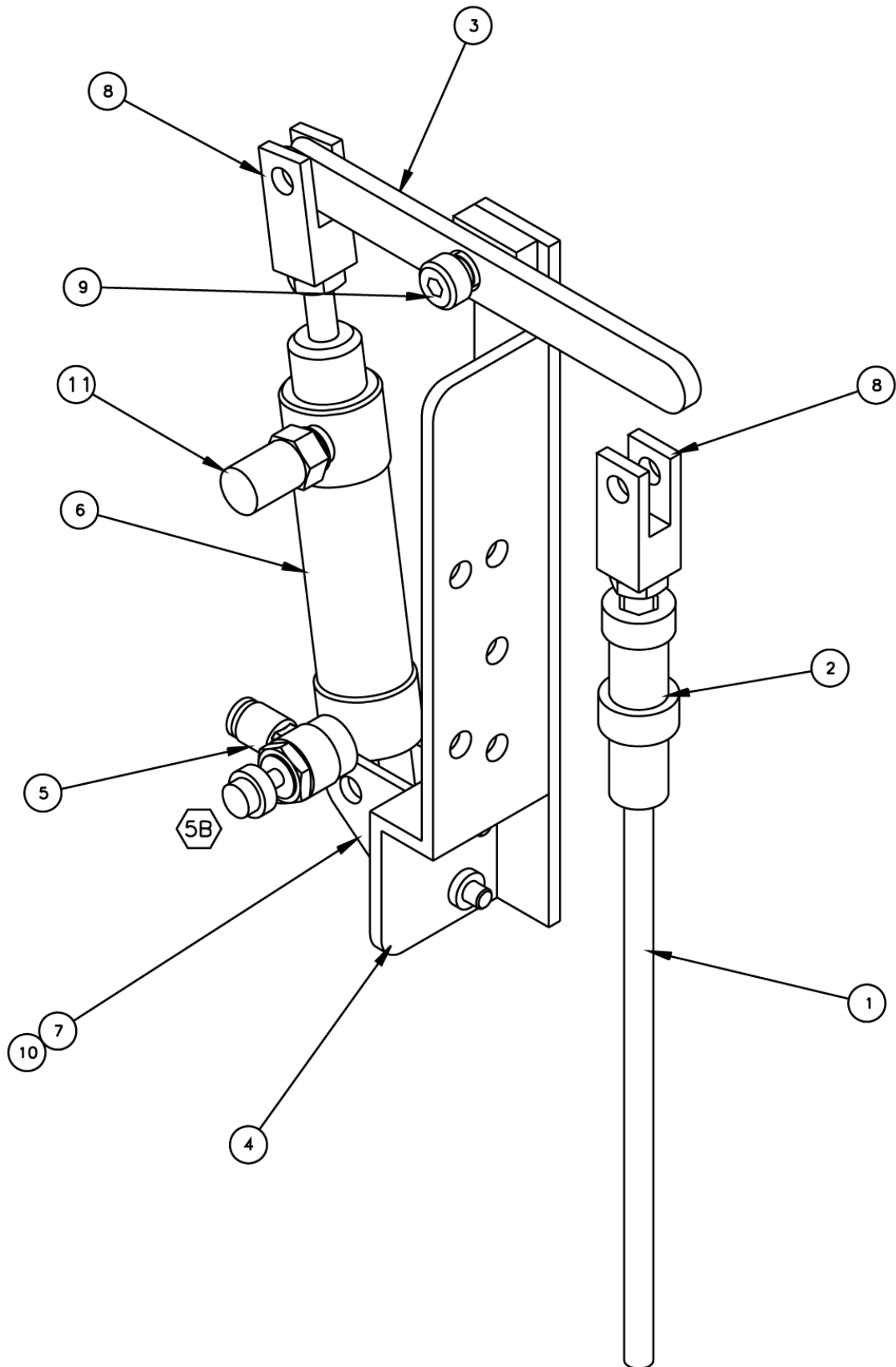

1335M-113 Foot Pressure Assembly

AAC Drawing Number 192700A Rev1

NO.	QTY	PART #	DESCRIPTION
1	1	1335M-106	Pressure Rod
2	1	1335M-107	Knob
3	1	1335M-108	Lever
4	1	1335M-112	Mnt Brkt
5	1	AA198RR508	Flow Control
6	1	AAC7DP-.5	Air Cylinder
7	1	AAFBP-11C	Pivot Brkt
8	2	AAFCT-7	Clevis
9	1	SSAS020024	Screw, Allen Shoulder
10	2	SSPP98032	Screw, Pan Head
11	1	AAFP18	Muffler

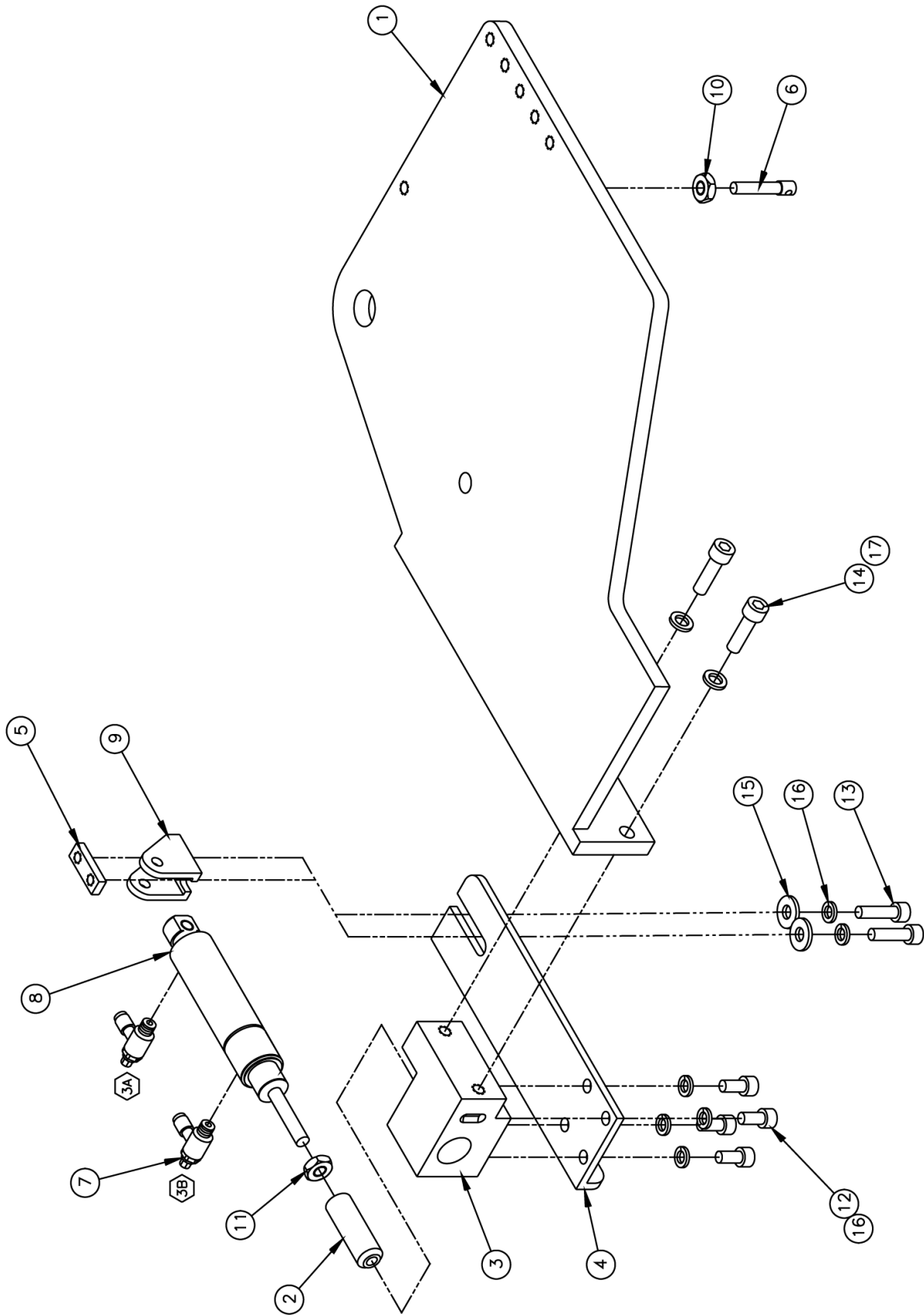

1335M-2200 Ruffler Mount Angle Assembly

AAC Drawing Number 192727C Rev1

NO.	QTY	PART #	DESCRIPTION
1	1	1335M-2005	Mounting Angle
2	1	1335M-2017	Rod End
3	1	1335M-2027	Cylinder Mnt
4	1	1335M-2028	Cylinder Support
5	1	1335M-2046	Nut Plate
6	1	A-2206A	Threaded Rod
7	2	AA198RA510	Flow Control
8	1	AAC8DP-.5	Air Cylinder
9	1	AAFBP-8C	Pivot Brkt
10	1	NNH10-32	Hex Nut
11	1	NNH10-32S	Hex Nut
12	4	SSSC90024	Screw, Socket Cap
13	2	SSSC90032	Screw, Socket Cap
14	2	SSSC98040	Screw, Socket Cap
15	2	WWF8	Flat Washer
16	6	WWL8	Lock Washer
17	2	WWL10	Lock Washer

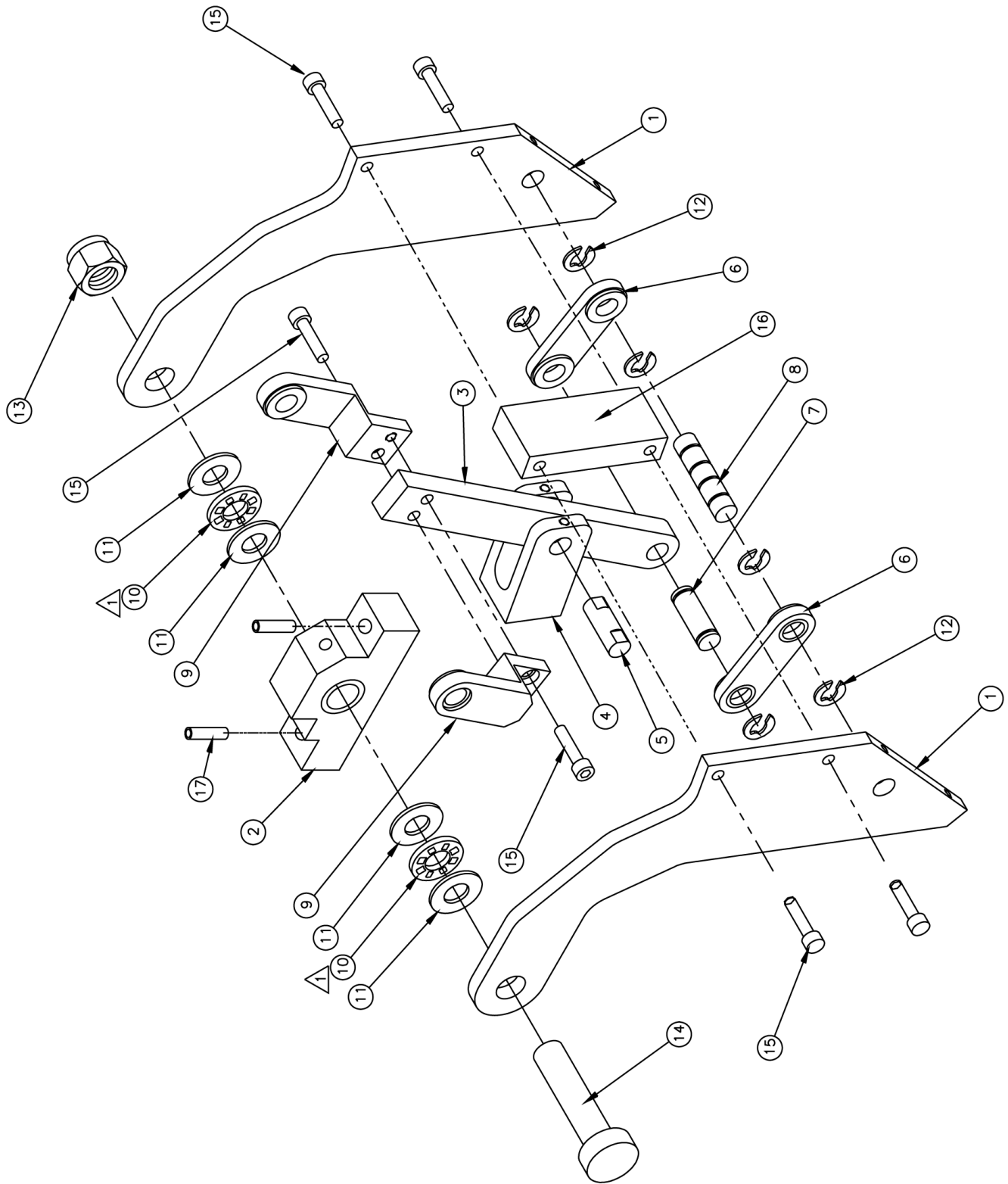

1335M-2300B Pivot Assembly

AAC Drawing Number 192985C Rev3

NO.	QTY	PART #	DESCRIPTION
1	2	1335M-2004A	Pivot Arm
2	1	1335M-2007	Pivot Block
3	1	1335M-2009	Drive Link
4	1	1335M-2010	Pivot Block
5	1	1335M-2011	Pivot Shaft
6	2	1335M-2012	Side Link
7	1	1335M-2013	Link Shaft
8	1	1335M-2014	Link Shaft
9	2	1335M-2015	Link Yoke
10	2	BBNTA815	Thrust Bearing
11	4	BBTRA815	Thrust Washer
12	6	MM8407A134	E-Ring
13	1	NNE1/2-13	Elastic Lock Nut
14	1	SSH45160	Screw, Hex Cap
15	6	SSSC98048	Screw, Socket Cap
16	1	1335373	Spacer
17	2	11S012X064	Spring Pin

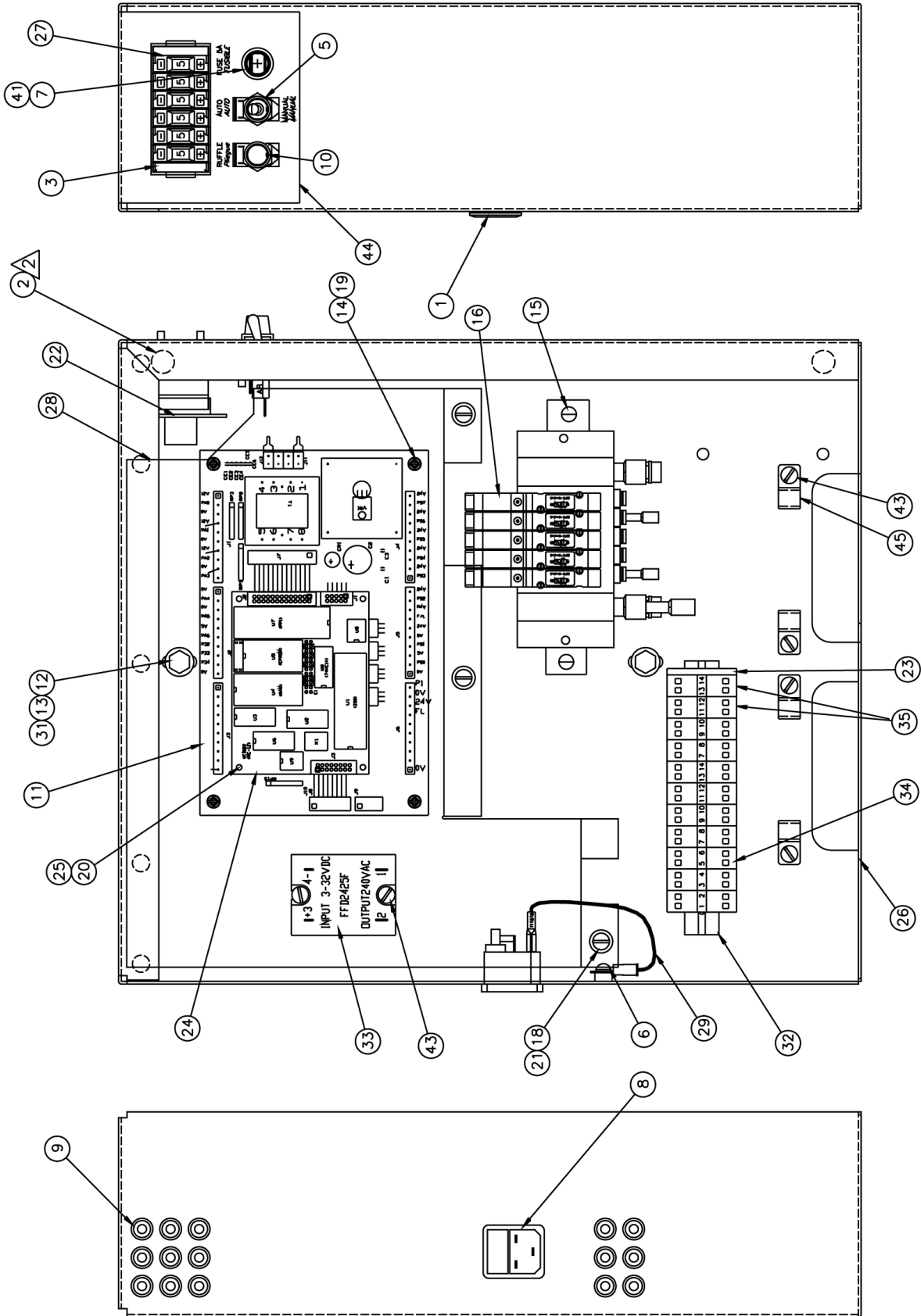

1335E-500 Control Box Assembly

AAC Drawing Number 192212A Rev1

NO.	QTY	PART #	DESCRIPTION	NO.	QTY	PART #	DESCRIPTION
1	1	MM40450010	SLIDE LOCK	28	1	1335M-501	CONTROL BOX COVER
2	2	MMSLD-ECH	BUMPER	29	1	1981A-511	GROUND WIRE
3	1	FFC5S1	END CAP, PAIR	30	1	EE37F3312	CEE POWER CORD
4	1	1987149F3	CABLE, 26 COND X3	31	2	WWFS1/4	FLAT WASHER, SAE
5	1	FF23F385	TOGGLE SWITCH	32	1	FF264-3BKT6	MOUNT, WAGO
6	1	SSPS98016	PAN HD SLOTTED SCREW	33	1	FFD2425F	SOLID STATE RELAY
7	1	FF342838A	FUSE HOLDER	34	9	FF264-341	WAGO, DUAL, GREY
8	1	FF10ESB1C	CONN, POWER ENTRY	35	1	FF264-347	WAGO, DUAL, GRN
9	15	EESB-375-3	HEYCO BUSHING	36	1	FFRK44T-4	CABLE, EYE, 12FT
10	1	FF23F118	PUSH BUTTON SWITCH	37	1	0211-703D	CABLE, PULLER SYNC
11	1	1987-149JC	PC BOARD	38	1	0211-705C	CABLE, TREADED
12	2	WWL1/4	LOCK WASHER, 1/4	39	1	0211-705D	CABLE, REMOTE
13	2	SSHC01032	HEX CAP SCREW	40	3	0411-1906B	CABLE, PROX SWITCH
14	4	SSPP80016	PAN HD PHILLIPS SCREW	41	1	FF313005	FUSE
15	2	SSPS98032	PAN HD SLOTTED SCREW	42	AR	1335E-WD	WIRING DIAGRAM
16	1	AAE1335-5	SOLENOID ASSY.	43	6	SSPS90024	PAN HD SLOTTED SCREW
17	1	1987-513A	CABLE	44	AR	1335MF-LAB1	LABEL, CONTROL BOX
18	3	WWFS10	WASHER, #10 SAE	45	4	AAF1/8	PLASTIC CLAMPS
19	4	FF67F4078	THREADED SPACER	46	1	AP-28-610UA	CABLE, JOG/DIR/ENABLE
20	4	FF89F2609	SPACER	47	1	AP-28-612RA	CABLE
21	3	SSPS98024	PAN HD SLOTTED SCREW	48	1	FF250LA40A	MTL OXIDE VARISTOR
22	1	1987-517	PC BOARD	49	6	SSPS90080	PAN HD SLOTTED SCREW
23	1	FF264-371	WAGO, END CAP	50	2	1335-022	CABLE, 3PIN FM MOLEX
24	1	FF1035-02	PC BOARD ISOLATION	51	1	1987149F5	CABLE, JUMPER
25	4	SSPP80096	PAN HD PHILLIPS SCREW	52	1	1987149F	CABLE, 26 CON RIBBON
26	1	1335M-505	CONTROL BOX WELDMENT	53	9	FF12F1042	BARRIER STRIP
27	6	FFC5.2LST1	THUMB WHEEL SWITCHES	54	AR	FF1024A-PGM	INS, FF1024A POT SETTINGS

Page 54

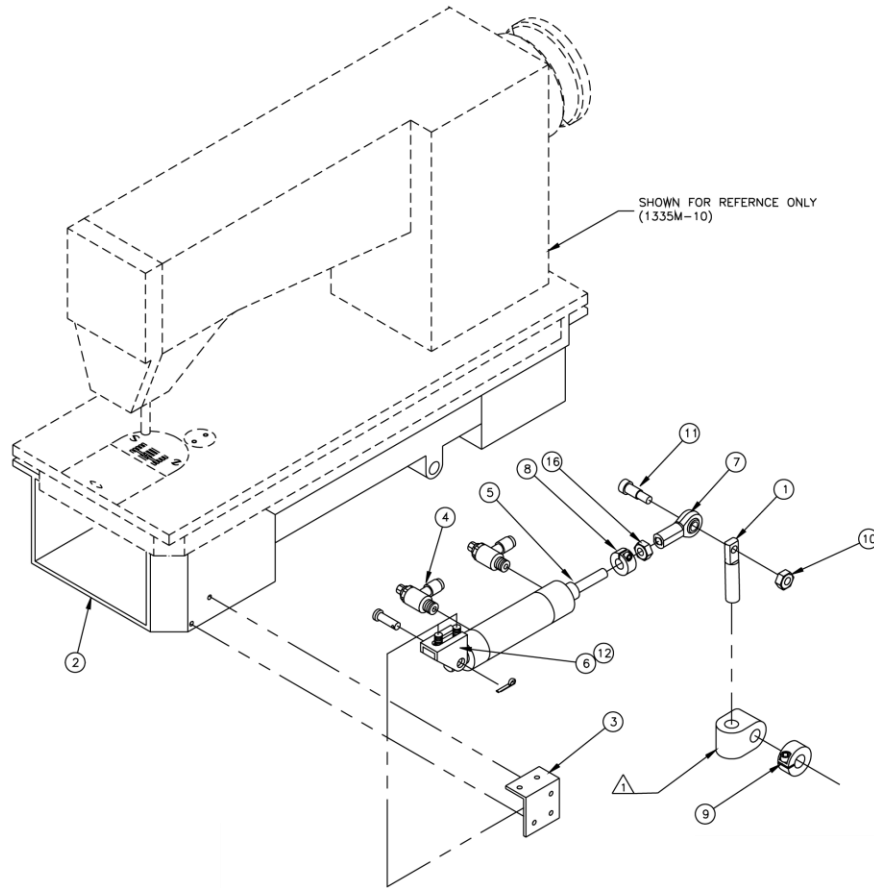

1335M-6000 Footlift Assembly

AAC Drawing Number 192736C Rev1

NO.	QTY	PART #	DESCRIPTION
1	1	1918-073	Footlift Link
2	1	32006517	Oil Tray
3	1	32006524	Pivot Mnt Brkt
4	2	AA198RA508	Flow Control
5	1	AAC6DP-2	Air Cylinder
6	1	AAFBP-11C	Pivot Brkt
7	1	BBAW-5Z	Rod End Bearing
8	1	CCCL5F	Clamp Collar
9	1	CCSCL7F	Clamp Collar
10	1	NNH1/4-20	Hex Nut
11	1	SSAS020032	Screw, Allen Shoulder
12	2	SSBC98024	Screw, Button Cap
13	2	SSSC98024	Screw, Socket Cap
14	2	WWL10	Lock Washer
15	2	WWFS10	Flat Washer
16	1	NNJ5/16-24	Jam Nut

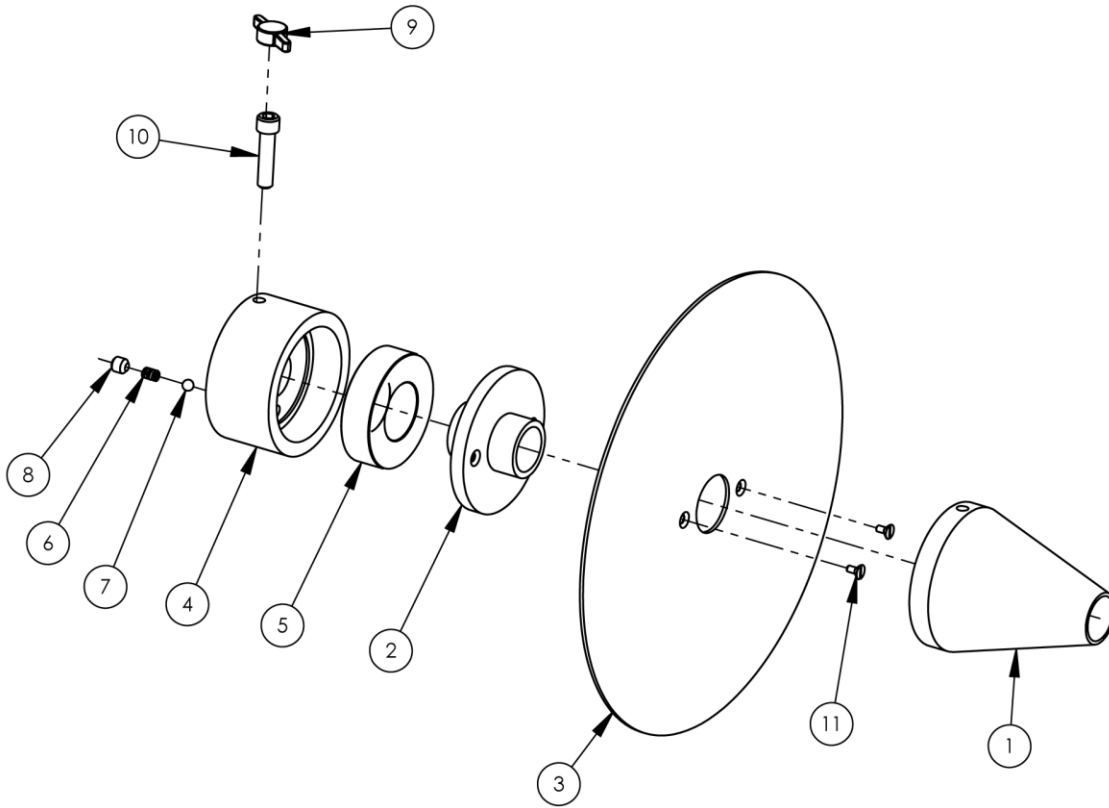

33008708 Ball Bearing Disc Assembly

AAC Drawing Number 9000904 Rev 4

NO.	QTY	PART #	DESCRIPTION
1	1	33008604	CONE, SPOOL
2	1	33008602	HUB, FLANGE 3/4 BORE
3	1	SEE CHART	SEE CHART
4	1	33008601	HUB, CENTER, 3/4 SHAFT
5	1	BB23216-88	BEARING, BALL, 1.0B
6	1	RRLC026B1	SPRING, COMP .026X.18X.25
7	1	JJ012	3/16 DIA. BALL
8	1	SSSP01016	1/4-20 X 1/4 NYLOCK
9	1	SSW#1_4	WING SCREW KNOB
10	1	SSSC01064	1/4-20 X 1 SOC CAP
11	2	SSFS80016	6-32 X 1/4, FLAT SLOT

-	BALL BEARING	DISC ASSEMBLY	33008732
3	1	33008632	DISC 32" DIA
-	BALL BEARING	DISC ASSEMBLY	33008724
3	1	33008624	DISC 24" DIA
-	BALL BEARING	DISC ASSEMBLY	33008716
3	1	33008616	DISC 16" DIA
-	BALL BEARING	DISC ASSEMBLY	33008708

1335E-WD Wiring Diagram

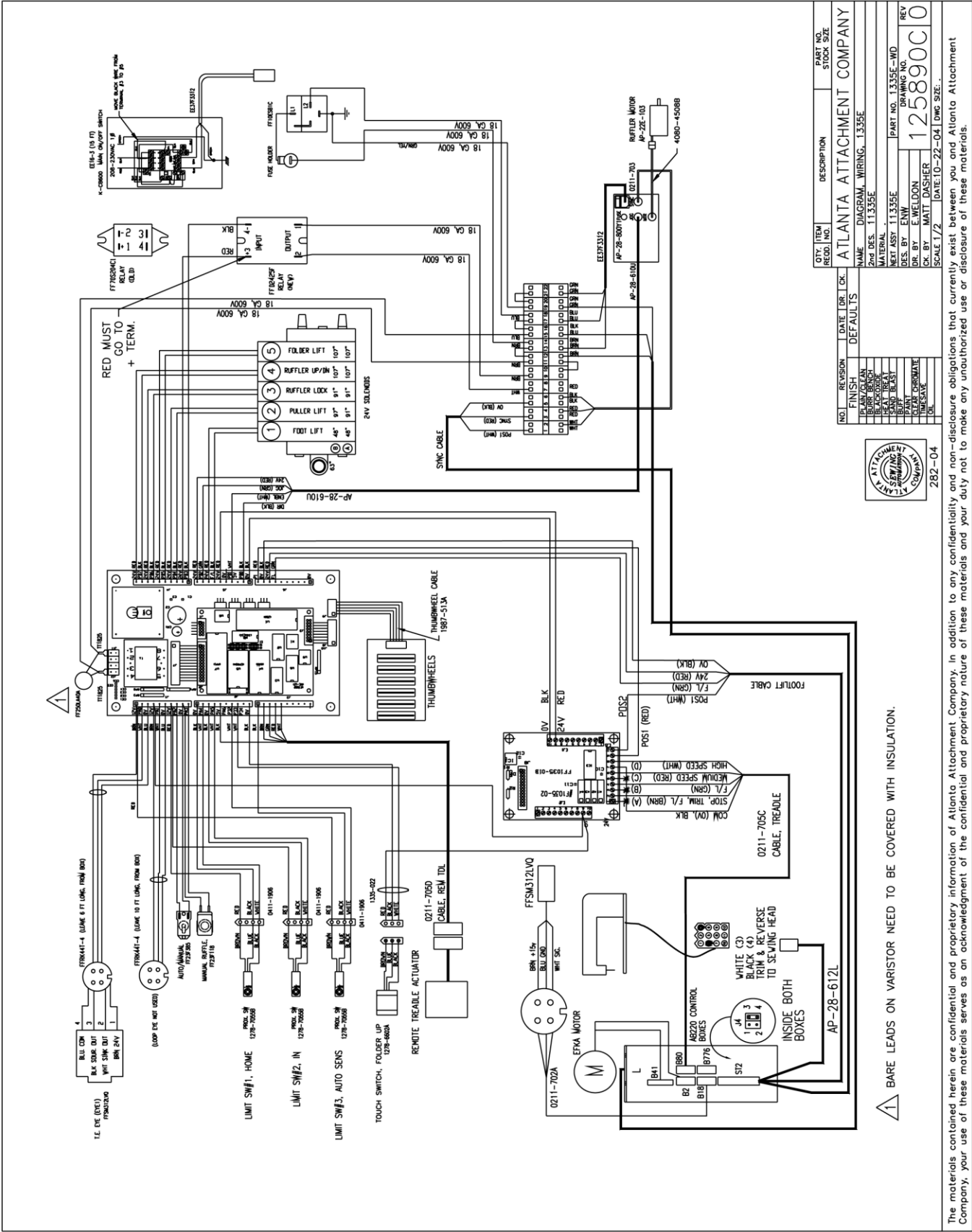

QTY	ITEM	DESCRIPTION	PART NO.
RECD.	NO.		STOCK SIZE
ATLANTA ATTACHMENT COMPANY			
NO.	REVISION	DATE	DR. CK.
DEFAULTS			
NAME: DIAGRAM, WIRING, 1335E			
MATERIAL: 2nd DES. 11.3.35E			
NEXT ASSY: 11.3.35E			
PART NO. 1335E-WD			
DRAWING NO. 125890C0			
DES. BY: ENW			
DR. BY: E. WELDON			
CHECKED BY: MATT DASHER			
SCALE: 1/2			
DATE: 10-22-04			
DWG. SIZE:			



⚠ BARE LEADS ON VARISTOR NEED TO BE COVERED WITH INSULATION.

The materials contained herein are confidential and proprietary information of Atlanta Attachment Company. In addition to any confidentiality and non-disclosure obligations that currently exist between you and Atlanta Attachment Company, your use of these materials serves as an acknowledgment of the confidential and proprietary nature of these materials and your duty not to make any unauthorized use or disclosure of these materials.

Atlanta Attachment Company (AAC) Statement of Warranty

Manufactured Products

Atlanta Attachment Company warrants manufactured products to be free from defects in material and workmanship for a period of eight hundred (800) hours of operation or one hundred (100) days whichever comes first. Atlanta Attachment Company warrants all electrical components of the Serial Bus System to be free from defects in material or workmanship for a period of thirty six (36) months.

Terms and Conditions:

- AAC Limited Warranty becomes effective on the date of shipment.
- AAC Warranty claims may be made by telephone, letter, fax or e-mail. All verbal claims must be confirmed in writing.
- AAC reserves the right to require the return of all claimed defective parts with a completed warranty claim form.
- AAC will, at its option, repair or replace the defective machine and parts upon return to AAC.
- AAC reserves the right to make the final decision on all warranty coverage questions.
- AAC warranty periods as stated are for eight hundred (800) hours or one hundred (100) days whichever comes first.
- AAC guarantees satisfactory operation of the machines on the basis of generally accepted industry standards, contingent upon proper application, installation and maintenance.
- AAC Limited Warranty may not be changed or modified and is not subject to any other warranty expressed or implied by any other agent, dealer, or distributor unless approved in writing by AAC in advance of any claim being filed.

What Is Covered

- Electrical components that are not included within the Serial Bus System that fail due to defects in material or workmanship, which are manufactured by AAC are covered for a period of eight hundred (800) hours.
- Mechanical parts or components that fail due to defects in material or workmanship, which are manufactured by AAC.
- Purchased items (sewing heads, motors, etc.) will be covered by the manufacturers (OEM) warranty.
- AAC will assist in the procurement and handling of the manufacturers (OEM) claim.

What Is Not Covered

- Parts that fail due to improper usage, lack of proper maintenance, lubrication and/or modification.
- Damages caused by; improper freight handling, accidents, fire and issues resulting from unauthorized service and/or personnel, improper electrical, plumbing connections.
- Normal wear of machine and parts such as Conveyor belts, "O" rings, gauge parts, cutters, needles, etc.
- Machine adjustments related to sewing applications and/or general machine operation.
- Charges for field service.
- Loss of time, potential revenue, and/or profits.
- Personal injury and/or property damage resulting from the operation of this equipment.

Declaración de Garantía

Productos Manufacturados

Atlanta Attachment Company garantiza que los productos de fabricación son libres de defectos de material y de mano de obra durante un periodo de ochocientos (800) horas de operación o cien (100) días cual llegue primero. Atlanta Attachment Company garantiza que todos los componentes del Serial bus son libres de defectos de material y de mano de obra durante un periodo de treinta y seis (36) meses.

Términos y Condiciones:

- La Garantía Limitada de AAC entra en efecto el día de transporte.
- Reclamos de la Garantía de AAC pueden ser realizados por teléfono, carta, fax o correo electrónico. Todo reclamo verbal tiene que ser confirmado vía escrito.
- AAC reserva el derecho para exigir el retorno de cada pieza defectuosa con un formulario de reclamo de garantía.
- AAC va, según su criterio, reparar o reemplazar las máquinas o piezas defectuosas devueltas para AAC.
- AAC reserva el derecho para tomar la decisión final sobre toda cuestión de garantía.
- Las garantías de AAC tiene una validez de ochocientas (800) horas o cien (100) días cual llega primero.
- AAC garantiza la operación satisfactoria de sus máquinas en base de las normas aceptadas de la industria siempre y cuando se instale use y mantenga de forma apropiada.
- La garantía de AAC no puede ser cambiado o modificado y no está sujeto a cualquier otra garantía implicado por otro agente o distribuidor menos al menos que sea autorizado por AAC antes de cualquier reclamo.

Lo Que Está Garantizado

- Componentes eléctricos que no están incluidos dentro del sistema Serial Bus que fallen por defectos de materiales o de fabricación que han sido manufacturados por AAC son garantizados por un periodo de ochocientas (800) horas.
- Componentes mecánicos que fallen por defectos de materiales o de fabricación que han sido manufacturados por AAC son garantizados por un periodo de ochocientas (800) horas.
- Componentes comprados (Motores, Cabezales,) son protegidos debajo de la garantía del fabricante.
- AAC asistirá con el manejo de todo reclamo de garantía bajo la garantía del fabricante.

Lo Que No Está Garantizado

- Falla de repuestos al raíz de uso incorrecto, falta de mantenimiento, lubricación o modificación.
- Daños ocurridos a raíz de mal transporte, accidentes, incendios o cualquier daño como resultado de servicio por personas no autorizados o instalaciones incorrectas de conexiones eléctricas o neumáticas.
- Desgaste normal de piezas como correas, anillos de goma, cuchillas, agujas, etc.
- Ajustes de la máquina en relación a las aplicaciones de costura y/o la operación en general de la máquina.
- Gastos de Reparaciones fuera de las instalaciones de AAC
- Pérdida de tiempo, ingresos potenciales, y/o ganancias.
- Daños personales y/o daños a la propiedad como resultado de la operación de este equipo.



Atlanta Attachment Company
Industrial Park Drive
Lawrenceville, GA 30046
770-962-7369
atlatt.com

Printed in the USA