



Models

**1331B**  
**1331BC**  
**1331BD**

Revision 1 Created July 9, 2024(wr)

# Technical Manual & Part Lists

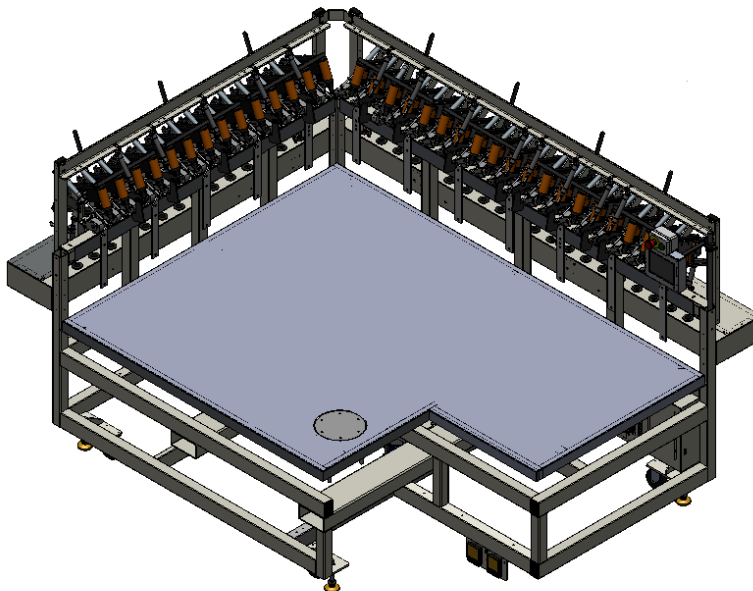
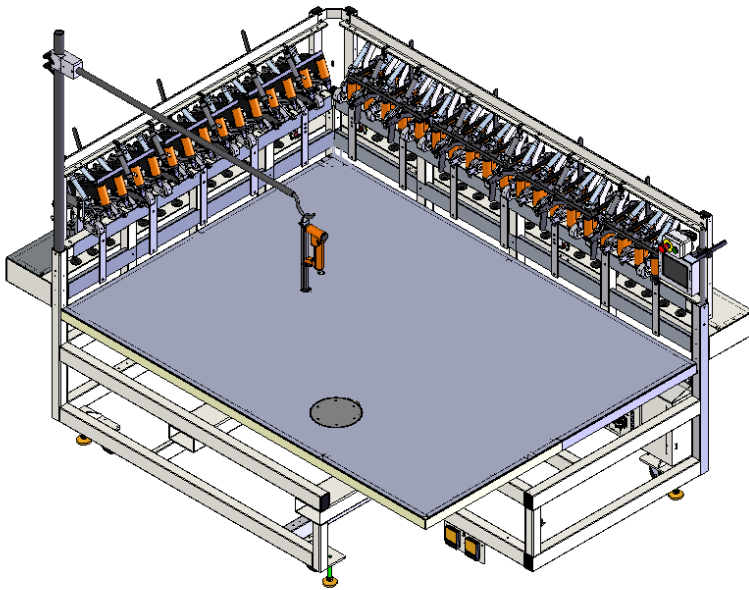

362 Industrial Park Drive  
Lawrenceville, GA 30046  
+1 (770-963) 7369  
[www.atlatt.com](http://www.atlatt.com)



# Atlanta Attachment Company, Inc.

## Confidential and Proprietary Information

The materials contained herein are confidential and proprietary information of Atlanta Attachment Company. In addition to any confidentiality and non-disclosure obligations that currently exist between you and Atlanta Attachment Company, your use of these materials serves as an acknowledgment of the confidential and proprietary nature of these materials and your duty not to make any unauthorized use or disclosure of these materials.

All materials contained herein are additionally protected by United States Copyright law and may not be used, disclosed, reproduced, distributed, published, or sold without the express written consent of Atlanta Attachment Company, which consent may be withheld in Atlanta Attachment Company's sole discretion. You may not alter or remove any copyright, trademark, or other notice from copies of these materials.

## IMPORTANT

It is important to read and understand the information contained within this manual before attempting to operate the machine. Atlanta Attachment Co., Inc. shall not be held liable for damage resulting from misuse of the information presented within and reserves the right to change the information contained within, without prior notification.

## Patents & Patents Pending

The sale of this product does not sell or otherwise transfer any license or other rights under any U.S. Patent or other corresponding foreign patent.

This equipment is manufactured under one or more of the following patents:

4,280,421 • 4,432,294 • 4,466,367 • 4,644,883 • 5,134,947 • 5,159,889 • 5,203,270 •  
5,373,798 • 5,437,238 • 5,522,332 • 5,524,563 • 5,562,060 • 5,634,418 • 5,647,293  
•5,657,711 • 5,743,202 • 5,865,135 • 5,899,159 • 5,915,319 • 5,918,560 • 5,924,376  
•5,979,345 • 6,035,794 • 6,055,921 • 6,202,579 • 6,279,869 • 6,295,481 • 6,494,225  
•6,523,488 • 6,574,815 • 6,802,271 • 6,834,603 • 6,968,794 • 6,994,043 • 7,543,364  
•7,574,788 • 7,647,876 • 7,735,439

Foreign Patents: 9-520,472 • 0,537,323 • 92,905,522.6 • 96,936,922.2 • 2,076,379 •  
2,084,055

Other U.S. and Foreign Patents Pending.

# Contents

<b>CONFIDENTIAL AND PROPRIETARY INFORMATION .....</b>	<b>0</b>
<b>SAFETY INSTRUCTION .....</b>	<b>0</b>
Important Notices.....	3
Maintenance .....	5
<b>1. INSTALLATION .....</b>	<b>8</b>
1.1. PARTS AND COMPONENTS .....	8
1.2. TECHNICAL DATA .....	9
1.3. ACCESSORIES.....	10
1.4. FOOTPRINT .....	11
1.5. MACHINE IDENTIFICATION LABEL.....	11
1.6. INSTALLATION & SET UP.....	11
1.6.1. Unloading .....	11
1.6.2. Leveling.....	12
1.6.3. Electrical.....	12
1.6.4. Air.....	12
1.6.5. Cleaning .....	12
1.6.6. Lubrication.....	12
1.6.7. Power “ON”.....	12
1.6.8. Electric Eyes.....	13
1.6.9. Lift Table Pedal.....	13
1.6.10. Rotary Table Foot Pedal.....	13
<b>2. OPERATION .....</b>	<b>14</b>
2.1. INDIVIDUAL COMPONENTS.....	14
2.1.1. Control Panel.....	15
a. Emergency Stop .....	15
b. Power On.....	15
c. Serial Bus control.....	15
2.1.2. Lift Table Pedals:.....	15
2.1.3. Rotation Plate Pedal .....	15
2.1.4. Manual Staple.....	16
2.1.5. Automatic Staples.....	16
2.1.6. Proximity Eyes.....	16
2.2. TOUCH-SCREEN.....	17
2.2.1. General Operation .....	17
1. Startup Sequence .....	17
2. Navigation .....	18
2.2.2. Available Menus .....	19
1. READY SEMI-AUTOMATIC. ....	19
2. READY- TRAINING: .....	19
3. PAUSED: .....	19
4. STAPLING FOUNDATION. ....	19
5. PIECE COUNTER. ....	19
2.2.3. Set up Screen.....	20
1. Reset Staple Left .....	20
2. SHOW ALL SETTINGS .....	20
3. SYSTEM INFORMATION: .....	20
4. SECURITY .....	20
5. ADVANCED ADJUSTMENTS .....	20
6. CONTRAST .....	20
2.3. OPERATION DESCRIPTION .....	21
2.3.1. Foundation Edge Stapling Cycle.....	21
2.3.2. Dust Cover Stapling Cycle .....	22

2.3.3.	Reloading the Staplers .....	23
MAINTENANCE .....		25
2.3.4.	General Safety Instructions.....	25
2.3.5.	Preventive Maintenance 8 Hrs.....	26
<b>3.</b>	<b>SERVICE.....</b>	<b>27</b>
3.1.	LOCKOUT/TAGOUT PROGRAM .....	27
3.2.	OPERATION SEQUENCE.....	28
3.3.	MECHANICAL ADJUSTMENTS.....	29
3.3.1.	Table .....	29
1.	Column Lift.....	29
2.	Alignment and Leveling.....	29
3.3.2.	Tension Wheel.....	29
1.	Movement .....	29
2.	Rotation.....	30
3.	Lower Position .....	30
3.3.3.	Border Clamp Fingers.....	30
3.3.4.	Staplers.....	30
1.	Height.....	30
2.	Position .....	31
3.	Firing Cylinder.....	31
4.	Bypass Valve .....	31
3.4.	PNEUMATIC .....	32
3.4.1.	Air Maintenance Unit FRL.....	32
1.	Pressure Relief Valve .....	32
2.	Pressure Regulator .....	32
3.	Air Filters .....	32
4.	Air Lubricator.....	32
3.4.2.	Solenoid Valve Stacking Manifold.....	33
3.4.3.	Pressures Adjustments.....	33
3.4.4.	Air Pressure Switch.....	33
3.5.	ELECTRICAL.....	34
3.5.1.	Ground .....	34
3.5.2.	Main Circuit Breaker .....	34
3.5.3.	Main Power Contactor .....	34
3.5.4.	Photoelectric Sensors.....	34
3.5.5.	Settings .....	35
	<b>SET THE RANGE.....</b>	<b>35</b>
	<b>OPERATION .....</b>	<b>35</b>
3.6.	SERIAL BUS .....	37
3.6.6.	Touch Screen .....	37
1.	Calibration.....	37
2.	Installing New Screen .....	38
3.6.7.	Modules.....	40
1.	Standard Modules.....	40
2.	Replacing a Module .....	40
3.6.8.	Program Update .....	41
3.6.9.	Expiration Count 911 .....	42
1.	Unlock Procedure .....	42
3.6.10.	Technical Screens .....	44
1.	Introduction .....	44
2.	Show All Settings .....	45
3.	System Information .....	45
4.	Advanced Set Up .....	46
5.	Advanced Manual .....	47
3.7.	MAINTENANCE .....	49

3.7.6.	General Safety Instructions.....	49
3.7.7.	Preventive Maintenance 40 Hrs.....	50
3.7.8.	Preventive Maintenance 960 Hrs.....	51
3.8.	TROUBLESHOOTING .....	52
3.8.6.	Screen Messages.....	52
<b>ASSEMBLY DRAWINGS &amp; PARTS LISTS .....</b>		<b>55</b>
<b>11331B S/A FOUNDATION STRETCHER .....</b>		<b>56</b>
<b>11331BC S/A FOUNDATION STRETCHER.....</b>		<b>57</b>
<b>11331BD S/A DIVAN FOUNDATION STRETCHER.....</b>		<b>58</b>
<b>1331100 MAIN ASSEMBLY (B &amp; BC MODELS).....</b>		<b>60</b>
<b>1331567 MAIN ASSEMBLY (BD MODEL) .....</b>		<b>63</b>
<b>1278-6010 START / STOP BUTTON ASSEMBLY (ALL MODELS).....</b>		<b>65</b>
<b>1331-KIT5 TABLE HEIGHT ADJUSTMENT KIT (ALL MODELS) .....</b>		<b>66</b>
<b>1331042 PIVOT LIFT ASSEMBLY (ALL MODELS).....</b>		<b>67</b>
<b>1331185 OVERHEAD STAPLE GUN HOLDER(ALL MODELS).....</b>		<b>68</b>
<b>1331903 LONG SIDETRACK ASSEMBLY (ALL MODELS) .....</b>		<b>69</b>
<b>1331908 SHORT SIDE TRACK ASSEMBLY (ALL MODELS).....</b>		<b>71</b>
<b>1331077 LONG SIDE STAPLE GUN ASSEMBLY (B &amp; BC) .....</b>		<b>73</b>
<b>1331078 SHORT STAPLE GUN ASSEMBLY (B &amp; BC).....</b>		<b>77</b>
<b>1331349 STAPLE GUN ASSEMBLY (ALL MODELS) .....</b>		<b>82</b>
<b>1331914 MANUAL STAPLER ASSEMBLY (ALL) .....</b>		<b>83</b>
<b>1331079 COVER STRETCH ROLLER ASSEMBLY (B &amp; BC).....</b>		<b>84</b>
<b>1331080 COVER STRETCH ROLLER ASSEMBLY (B &amp; BC).....</b>		<b>86</b>
<b>1331081 COVER STRETCH ROLLER ASSEMBLY (B &amp; BC).....</b>		<b>88</b>
<b>1331393 TABLETOP ASSEMBLY (BC &amp; BD) .....</b>		<b>90</b>
<b>1331140 TABLETOP ASSEMBLY (B).....</b>		<b>91</b>
<b>1331178 PNEUMATIC PANEL (ALL).....</b>		<b>92</b>
<b>1331247 CORNER SUPPORT ASSEMBLY, RH (ALL MODELS) .....</b>		<b>93</b>
<b>1331504 TABLE LIFT PEDAL ASSEMBLY (ALL MODELS).....</b>		<b>94</b>
<b>1331900 CONTROL BOX (ALL MODELS).....</b>		<b>95</b>
<b>13452000C SQUARE TABLE LIFT ASSEMBLY (B &amp; BC).....</b>		<b>97</b>
<b>1536-069A FOOTSWITCH ASSEMBLY (ALL).....</b>		<b>99</b>
<b>26254C AIR RESERVOIR(ALL MODELS) .....</b>		<b>100</b>
<b>1331559 LONG SIDE STAPLE GUN ASSEMBLY (BD).....</b>		<b>101</b>
<b>1331564 SHORT STAPLE GUN ASSEMBLY (BD).....</b>		<b>103</b>
<b>1331558 COVER STRETCH ROLLER ASSEMBLY (BD).....</b>		<b>104</b>
<b>1331560 COVER STRETCH ROLLER ASSEMBLY (BD).....</b>		<b>106</b>

<b>1331563 COVER STRETCH ROLLER ASSEMBLY (BD)</b> .....	<b>108</b>
<b>1331565 SQUARE TABLE LIFT ASSEMBLY (BD)</b> .....	<b>110</b>
<b>1331-PD2 REV 8 PNEUMATIC DIAGRAM (B, BC &amp; BD MODELS)</b> .....	<b>112</b>
<b>1331-WD REV 6 WIRING DIAGRAM (B &amp; BD MODELS)</b> .....	<b>113</b>
<b>1331-WD REV 8 (GATEWAY) WIRING DIAGRAM (BC MODEL)</b> .....	<b>114</b>
<b>STATEMENT OF WARRANTYMANUFACTURED PRODUCTS</b> .....	<b>115</b>
Terms and Conditions: .....	115
What Is Covered .....	115
What Is Not Covered.....	115
TRAINING .....	116
<b>NOTES:</b> .....	<b>117</b>
<b>INDEX</b> .....	<b>118</b>

## Safety Instruction



This part of the Instruction Material is provided for the safe use of your equipment. It contains important information to help work safely with the unit and describes the dangers inherent in machinery. Some of these dangers are obvious, while others are less evident.

### Mandatory Information

All persons operating and/or working on the Workstation 1331B&BD, should read and understand all parts of the Safety Instructions. This applies, in particular, for persons who only operate and/or work on the unit occasionally (e.g. for maintenance and repair). Persons who have difficulty reading must receive particularly thorough instruction.

### Scope of the Instruction Material

The Instruction Material comprises:

- Safety information
- Operator Instructions
- Electrical and Pneumatic diagrams

And may also include.

- A list of recommended spare parts
- Instruction Manual(s) for components made by other manufacturers
- The layout and installation diagram containing information for installation

### Intended Use

Our machines are designed and built in line with the state of the art and the accepted safety rules. However, all machines may endanger the life and limb of their users and/or third parties and be damaged or cause damage to other property, particularly if they are operated incorrectly or used for purposes other than those specified in the Instruction Manual.

Exclusion of Misuse



Non-conforming uses include, for example, using the equipment for something other than it was designed for, as well as operation without duly installed safety equipment. The risk rests exclusively with the end user.

Conforming use of the machine includes compliance with the technical data, information and regulations in all parts of the complete Instruction Material, as well as compliance with the maintenance regulations. All local safety and

accident prevention regulations must also be observed.

### Liability

The machine should only be operated when in perfect working order, with due regard for safety and the potential dangers, as well as in accordance with the Instruction Material. Faults and malfunctions capable of impairing safety should be remedied immediately. We cannot accept any liability for personal injury or property damage due to operator errors or non-compliance with the safety instructions contained in this booklet. The risk rests exclusively with the end user.

The Instruction Material should always be kept near the machine so that it is accessible to all concerned.

The local, general, statutory, and other binding regulations on accident prevention and environmental protection must also be observed in addition to the Instruction Material. The operating staff must be instructed accordingly. This obligation also includes the handling of dangerous substances and provision/use of personal protective equipment.

The Instruction Material should be supplemented by instructions, including supervisory and notification duties with due regard for special operational features, such as the organization of work, work sequences, the personnel deployed, etc.

## Safety

---

The personnel's awareness of the dangers and compliance with the safety regulations should be checked at irregular intervals.

### Choice and Qualification of Personnel

Ensure that work on the machine is only carried out by reliable persons who have been appropriately trained for such work - either within the company, by our field staff or at our office - and who have not only been duly appointed and authorized but are also fully familiar with the local regulations. Work on the machine should only be carried out by skilled personnel, under the management and supervision of a duly qualified engineer.

This not only applies when the machine is used for production, but also for special work associated with its operation (start-up and maintenance), especially when it concerns work on the hydraulic or electrical systems, as well as on the software/serial bus system.

### Training

Everyone working on or with the machine should be duly trained and informed with regard to correct use of the safety equipment, the foreseeable dangers which may arise during operation of the machine and the safety precautions to be taken. In addition, the personnel should be instructed to check all safety mechanisms at regular intervals.

### Responsibilities

Clearly define exactly who is responsible for operating, setting-up, servicing and repairing the machine. Define the responsibilities of the machine operator and authorize him to refuse any instructions by third parties if they run contrary to the machine's safety. This applies in particular for the operators of machines linked to other equipment. Persons receiving training of any kind may only work on or with the machine under the constant supervision of an experienced operator. Note the minimum age limits permitted by law.

### A Word to the Operator

The greatest danger inherent in our machines: is that of fingers, hands or loose clothing being drawn into a machine by live, coasting, or rotating tools or assemblies or of being cut by sharp tools or burned by hot elements.

## **Always be conscious of these dangers!**

### Safety Equipment on the Machines



All machines are delivered with safety equipment, which shall not be removed or bypassed during operation.

The correct functioning of safety equipment on machines and systems should be checked every day and before every new shift starts, after maintenance and repair work, when starting up for the first time and when restarting (e.g. after prolonged shutdowns).

If safety equipment has to be dismantled for setting-up, maintenance or repair work, such safety equipment shall be replaced and checked immediately upon completing the maintenance or repair work.

All protective mechanisms shall be fitted and fully operational whenever the machine is at a standstill or if it has been shut down for a longer period of time.

### Damage

If any changes capable of impairing safety are observed in the machine or its mode of operation, such as malfunctions, faults or changes in the machine or tools, appropriate steps must be taken immediately, the machine switched off and a proper lockout tagout procedure followed. The machine should be examined for obvious damage and defects at least once per

## Safety

---

shift. Damage found shall be immediately remedied by a duly authorized person before resuming operation of machine.

The machine should only be operated when in perfect working order and when all protective mechanisms and safety equipment, such as detachable protective mechanisms, emergency STOP systems, etc. are in place and operational.

### Faults or Errors

The machine must be switched off and all moving or rotating parts allowed to come to a standstill and secured against accidental restart before starting to remedy any faults or errors.

### Signs on the Machine

Safety and danger signs on the machine should be observed and checked at regular intervals to ensure that they are complete and undamaged. They should be clearly visible and legible at all times.

### Clothing, Jewelry, Protective Equipment

Long loose hair, loose-fitting clothes, gloves and jewelry, including rings, should be avoided in order to avoid injuries due to being caught, drawn in and wound up inside the machine.

### Protective Eyewear

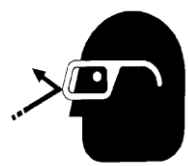

Protective eyewear that has been tested by the local authorities should be worn whenever there is a possibility of loose or flying objects or particles such as when cleaning the machine with compressed air.

### Tools

Always count the number of tools in your possession before starting work on the machine. This will allow you to check that no tools have been left behind inside the machine. Never leave a tool in the machine while working.

### Oils, Lubricants, Chemicals

Note the applicable safety regulations for the product used.

### No Smoking, Fire, Explosion Hazard

Smoking and open flame (e.g. welding work) should be prohibited in the production area due to the risk of fire and explosions.

### Workplace

A clear working area without any obstructions whatsoever is essential for safe operation of the machine. The floor should be level and clean, without any waste.

The workplace should be well lit, either by the general lighting or by local lights.

### Emergency STOP

The emergency STOP buttons bring all machine movements to a standstill. Make sure you know exactly where they are located and how they work. Try them out. Always ensure easy access to the nearest emergency STOP button while working on the machine.

### First Aid

1. Keep calm even when injured.
2. Clear the operator from the danger zone. The decision of what to do and whether to seek additional assistance rests entirely with you, particularly if someone has been trapped.
3. Give First Aid. Special courses are offered by such organizations as the employers' liability insurance association. Your colleagues should be able to rely on you and vice versa.
4. Call an ambulance. Do you know the telephone numbers for the ambulance service, police and fire service?

## Important Notices

### Reporting and Fighting Fires

Read the instructions posted in the factory with regard to reporting fires and the emergency exits. Make sure you know exactly where the fire extinguishers and sprinkler systems are located and how they are operated. Pass on the corresponding information to the firemen when they arrive. Ensure there are enough signs to avoid fire hazards.

The following fire extinguishers may be used:

- Dry powder extinguishers, ABC fire-extinguishing powder.
- Carbon dioxide fire extinguishers to DIN 14461 for electronic components. Great care must be exercised when using carbon dioxide fire extinguishers in confined, badly ventilated rooms (see DIN 14406 and 14270).

Isolate the machine from the power supply if a fire breaks out. Do not use water on burning electrical parts until it is absolutely certain that they have been completely disconnected from the power supply. Burning oils, lubricants, plastics, and coatings on the machine can give off gases and vapors that may be harmful to your health.

A qualified person should be consulted to repair the damage after a fire.

### Electrical Power Supply



Before undertaking any maintenance or repair work on the machine, switch off the electrical power to the machine at the main source and secure it with a padlock so that it cannot be switched on again without authorization.

In practice, this may mean that the technician, electrician, and operator all attach their own padlock to the master switch simultaneously so that they can carry out their work safely. Locking extension plates should be available for multiple locks if required. The primary purpose for a lockout/tagout

procedure is to protect workers from injury caused by unexpected energizing or start-up of equipment.

Energy sources (electrical/pneumatic/hydraulic, etc.) for the equipment shall be turned off or disconnected and the switches locked or labeled with a warning tag. It is the responsibility of the employer to establish control procedures. Follow lockout/tagout procedures before, setup and/or any service or maintenance work is performed, including lubrication, cleaning or clearance of jams.

### **Caution: The machine is still not completely de-energized even when the master switch is off.**

- Electricity - The machine is always isolated from the electrical power supply whenever the master switch has been switched off. However, this does not apply for the power supply in the control cabinet, nor for equipment that does not draw its power via the master switch.

- Pneumatic / hydraulic energy - Almost all our machines carry compressed air. In addition to switching off the master switch, the air supply must also be disconnected, and the machine checked to ensure it is depressurized before starting any work on the machine; otherwise the machine may execute uncontrolled movements.

- Kinetic energy - Note that some motors or spindles, for example, may continue to run or coast run on after being switched off.

Potential energy - Individual assemblies may need to be secured if necessary for repair work.

### **Delivery of the Machine/Packaging**

Note any markings on the packaging, such as weights, lifting points and special information. Avoid temperature fluctuations. Condensation may damage the machine.

### **Transport Damage**

The packaging and machine must immediately be examined for signs of damage in transit. Such damage must be reported to the shipper/transporter within the applicable time limits. Contact Atlanta Attachment Company and/or your transport insurer immediately, if signs of damage are visible. Never operate a damaged machine.

### **Interim Storage**

If the machine has to be stored temporarily, it must be oiled or greased and stored in a dry place where it is protected from the weather in order to avoid damage. A corrosion-inhibiting coating should be applied if the machine has to be stored for a longer period of time and additional precautions taken to avoid corrosion.

### **Transporting the Machine**

Disconnect the machine from all external connections and secure any loose assemblies or parts. Never step under a suspended load. When transporting the machine or assemblies in a crate, ensure that the ropes or arms of a forklift truck are positioned as close to the edge of the crate as possible. The center of gravity is not necessarily in the middle of the crate. Note the accident prevention regulations, safety instructions and local regulations governing transport of the machine and its assemblies.

Only use suitable transport vehicles, hoisting gear and load suspension devices that are in perfect working order and of adequate carrying capacity. Transport should only be entrusted to duly qualified personnel.

Never allow the straps to rest against the machine enclosure and never push or pull sensitive parts of the machine. Ensure that the load is always properly secured. Before or immediately after loading the machine, secure it properly and affix corresponding warnings. All transport guards and lifting devices must be removed before the machine is started up again. Any parts that are to be removed for transport must be carefully refitted and secured before the machine is started up again.

### **Workplace Environment**

Our machines are designed for use in enclosed rooms: Permissible ambient temperature approx. 5 - 40 °C (40 - 104 °F). Malfunctions of the control systems and uncontrolled machine movements may occur at temperatures outside this range.

Protect against climatic influences, such as electrostatic charges, lightning strikes, hail, storm damage, high humidity, salinity of the air in coastal regions.

Protect against influences from the surroundings: no structure-borne vibrations, no grinding dust, or chemical vapors.

Protect against unauthorized access.

Ensure that the machine and accessories are set up in a stable position.

Ensure easy access for operation and maintenance (Instruction Manual and layout diagram); also verify that the floor is strong enough to carry the weight of the machine.

## Safety

---

### Local Regulations

Particular attention must be paid to local and statutory regulations, etc. when installing machines and the plant (e.g. with regard to the specified escape routes). Note the safety zones in relation to adjacent machines.

## Maintenance

### General Safety Instructions

The machine shall be switched off, come to a standstill, and be secured so that it cannot be switched on again inadvertently before starting any maintenance work whatsoever. Use proper lockout/tagout procedures to secure the machine against inadvertent startup.

Remove any oil, grease, dirt and waste from the machine, particularly from the connections and screws, when starting the maintenance and/or repair work. Do not use any corrosive-cleaning agents. Use lint-free rags.

Retighten all screw connections that have to be loosened for the maintenance and repair work. Any safety mechanisms that have to be dismantled for setting-up, maintenance or repair purposes must be refitted and checked immediately after completing the work.

### Maintenance Care, Adjustment

The activities and intervals specified in the Instruction Manual for carrying out adjustments, maintenance and inspections must be observed, and parts replaced as specified.

All hydraulic and pneumatic lines should be examined for leaks, loose connections, rubbing and damage whenever the machine is serviced. Any defects found must be remedied immediately.

### Waste, Disassembly, Disposal

Waste products should be cleared from the machine as soon as possible as not to create a fire hazard.

Ensure that fuels and operating lubricants, as well as replacement parts are disposed of in a safe and ecologically acceptable manner. Note the local regulations on pollution control.

When scrapping (disassembling) the machine and its assemblies, ensure that these materials are disposed of safely. Either commission a specialist company familiar with the local regulations or note the local regulations when disposing of these materials yourself. Materials should be sorted properly.

## Repair

### Replacement Parts

We cannot accept any liability whatsoever for damage due to the use of parts made by other manufacturers or due to unqualified repair or modification of the machine.

### Repair, Electrical

The power supply must be switched off (master switch off) and secured so that it cannot be switched on again inadvertently before starting any work on live parts.

Those parts of the machine and plant on which inspection, maintenance or repair work is to be carried out must be isolated from the power supply, if specified. The isolated parts must first be checked to determine that they are truly de-energized before being grounded and short-circuited. Adjacent live parts must also be isolated.

The protective measures implemented (e.g. grounding resistance) must be tested before restarting the machine after all assembly or repair work on electric parts.

Signal generators (limit switches) and other electrical parts on the safety mechanisms must not be removed or bypassed. Only use original fuses or circuit overloads with the specified current

## Safety

---

rating. The machine must be switched off immediately if a fault develops in the electrical power supply.

The electrical equipment of our machines must be checked at regular intervals and any defects found must be remedied immediately.

If it is necessary to carry out work on live parts, a second person should be on hand to operate the emergency OFF switch or master switch with voltage release in the event of an emergency. The working area should be cordoned off and marked by a warning sign. Only use electrically insulated tools.

## Ventilation/Hazardous Gases

It is the end users responsibility to ensure adequate ventilation is provided to exhaust any and all noxious or hazardous gases that may be present in the working environment.

### Hydraulic and Pneumatic Systems

Work on hydraulic or pneumatic equipment shall only be carried out by persons with training, knowledge, and experience of hydraulic systems. Pressure lines shall be depressurized before starting any repair work.

## General Liability

Liability for machine damage and personal injury is extinguished completely if any unauthorized conversions or modifications are undertaken. The machine must not be modified, enlarged, or converted in any way capable of affecting safety without the manufacturer's prior approval.

## Starting Machine Movements

Read the Instruction Manual carefully to establish which keys and functions start machine movements.

## A Word to the End User

The end user has sole responsibility to enforce the use of safety procedures and guards on the machine. Any other safety devices or procedures due to local regulations should be retrofitted in accordance to these regulations and/or the EC Directive on the safety of machines.

Operator's position must always be readily accessible. Escape routes must always be kept clear and safety areas should be identified.

## Safety Precautions

Safety should be a constant concern for everyone. Always be careful when working with this equipment. While normal safety precautions were taken in the design and manufacture of this equipment, there are some potential safety hazards.

Everyone involved with the operation and maintenance of this equipment should read and follow the instructions in this manual. Operate the equipment only as stated in this manual. Incorrect use could cause damage to the equipment or personal injury.

It is the owner's responsibility to make certain that the operator reads and understands this manual before operating this equipment. It is also the owner's responsibility to make certain that the operator is a qualified and physically able individual, properly trained in the operation of this equipment.

Specific safety warning decals are located on the equipment near the immediate areas of potential hazards. These decals should not be removed or obliterated. Replace them if they become non-readable.

- ALWAYS keep safety shields and covers in place, except for servicing.
- ALWAYS operate equipment in daylight or with adequate working lights.

## Safety

---

- Follow daily and weekly checklists, making sure hoses are tightly secured and bolts are tightened.
- ALWAYS watch and avoid holes or deep depressions.

ALWAYS wear adequate eye protection when servicing the hydraulic system and battery.

- NEVER operate a poorly maintained machine.
- NEVER allow persons to operate this machine without proper instruction.
- NEVER put hands or feet under any part of the machine while it is running.
- NEVER attempt to make any adjustments or repairs to the machine while running. Repairs or maintenance should be performed by trained personnel only.
- NEVER work under the machine unless it is safely supported with stands, blocks or a hoist and blocks.
- NEVER touch hot parts of machine.

# 1. INSTALLATION

**NOTE:** It is important that the machine technician read this manual and is familiar with all the functions and safety concerns of the unit before Installing and operating.

## 1.1. Parts and Components

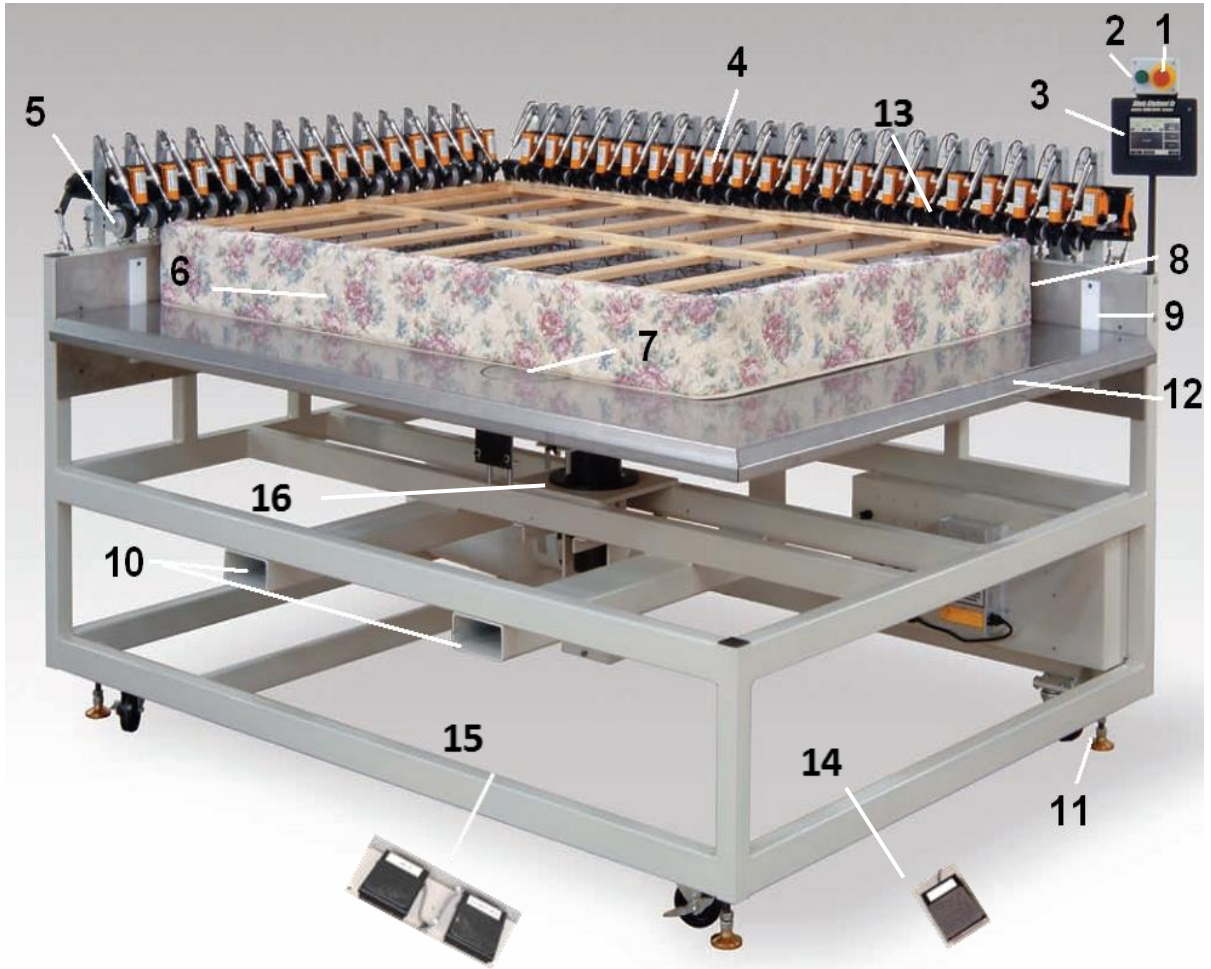



1	Emergency Stop	9	Feed Stops
2	Start Button	10	Forklift Channels
3	Touch Screen Panel	11	Leveling Bolts
4	Staplers	12	Stainless Steel Table
5	Tension Wheels	13	Border Clamps
6	Foundation	14	Rotary Table Foot Pedal
7	Rotary Table	15	Table Foot Pedal
8	Load Sensors	16	Table Column Lifter

## 1.2. Technical Data

		<b>1331B Series. Automatic Ergonomic Foundation Cover Stretch and Staple</b>						1/1/2017
		11331B	11331BC	11331BD	11331BL	11331BRB	11331BX	
<b>Part Number</b>	9005254	9005255	9003551	9002710	9004444			
<b>Description</b>	Automatic Ergonomic Foundation Cover Stretch and Stapler.	Ergonomic Foundation Cover Stretch and Staple	Automatic Ergonomic Divan Foundation Stapler	Automatic Ergonomic Foundation Stretch and Stapler. Left Hand	Stapler, Auto Upholstery Foundation W/Bull Nose		Automatic Ergonomic Foundation Cover Stretch and Stapler. Stretch Version	
<b>Price</b>	\$75,775.00	\$75,775.00	\$78,775.00	\$76,875.00			\$74,775.00	
<b>Notes</b>	Standard Version	With cut out table. Option available for the operator to get easy access when running small beds	Narrow wood support up to 1/2 inches narrow	To run machines in conveyor with one is on the left and another on the right of it. Basically is a mirrored version			Foundation up to 19 1/2" high. Option available for the use very tall foundations for example with drawers as storages areas.	
<b>Voltage (v/ph/hrz)</b>	220v- 1PH - 50/60HZ	220v- 1PH - 50/60HZ	220v- 1PH - 50/60HZ	220v- 1PH - 50/60HZ	220v- 1PH - 50/60HZ		220v- 1PH - 50/60HZ	
<b>Current (amps)</b>	3	3	3	3	3		3	
<b>Air Pressure (psi/bar)</b>	80/5.5	80/5.5	80/5.5	80/5.5	80/5.5		80/5.5	
<b>Air consumption (cfm)</b>	20	20	20	20	20		20	
<b>Shipping Weight (lbs/kg)</b>	2050/930	2050/930	2050/930	2050/930	2050/930		2050/930	
<b>Dimensions (h/w/l)- inches/cms</b>	60x105x92/152x266x233	60x105x92/152x266x233	60x105x92/152x266x233	60x105x92/152x266x233	60x105x92/152x266x233		60x105x92/152x266x233	
<b>Minimum Height inches/cm(w/spacer)</b>	4.5/11.5	4.5/11.5	4.5/11.5	4.5/11.5	4.5/11.5		4.5/11.5	
<b>Table Stroke "in/cm"</b>	6/15.2	6/15.2	6/15.2	6/15.2	6/15.2		6/15.2	
<b>Standar Height "in/cm"</b>	10.5/26.7	10.5/26.7	10.5/26.7	10.5/26.7	10.5/26.7		10.5/26.7	
<b>Maximum Height in/cm (with spacer)</b>	13.5/34.3	13.5/34.3	13.5/34.3	13.5/34.3	13.5/34.3		13.5/34.3	
<b>Foot Print - "Inches/cm"</b>	120x120/305x305	120x120/305x305	120x120/305x305	120x120/305x305	120x120/305x305		120x120/305x305	
<b>Staples</b>	BA-7110 BA-7112	BA-7110 BA-7112	BA-7110 BA-7112	BA-7110 BA-7112	BA-7110 BA-7112		BA-7110 BA-7112	
<b>Production</b>								
<b>"Foundations per Hour"</b>	150	150	150	150	150		150	
<b>"Foundations + Dustcover per Hour"</b>	80	80	80	80	80		80	

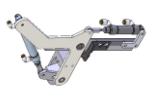
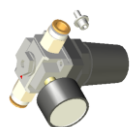
### 1.3. Accessories

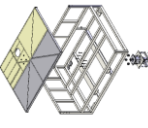
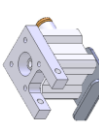
		<h2>1331 Accessories</h2>														<p>1/1/2017</p>	
																1331-KIT1	1331-KIT2
<b>Kits</b>																	
<b>Drawing</b>																	
<b>Description</b>		DOUBLE STAPLE, DUST COVER	STAPLE VALVE RELOCATE KIT	STAPLER LOW PRESSURE KIT	KIT, ACTUATOR UPDATE FOR SQUARE COLUMN	Table Height Adjustment Kit, 8.5"-13.5" Max Bed Height	Kit, Adnl Gun, Tension Assy Req for Cal King										
<b>Price</b>		550.00															1261.84
<b>Notes</b>		Do not use	Standard on all units	Do not Use Specific customer request	Standard on all units	Standard on all units	Standard on all units	Standard on all units	Standard on all units	Standard on all units	Standard on all units	Standard on all units	Standard on all units	Standard on all units	Standard on all units	Standard on all units	Standard on all units
<b>Kits</b>																	
<b>Drawing</b>																	
<b>Description</b>		Kit, Sealy Safety Guards Gun Shields, Safety Eyes	KIT, CORNER SUPPORT, RH 1331	KIT, CORNER SUPPORT, LH 1331	KIT, DIVAN CONVERSION CLAMP, TENSION WHEEL, ETC	UPDATE, TRIGGER CYLINDER SPRING RETURN CYL 1331B	KIT, 1/2" CROWN STAPLE GUN CONVERSION, 21680B-ALM										
<b>Price</b>		3833.00															
<b>Notes</b>		Use for "CE" machines	Standard on all units	Standard on all units	Standard on all units	Standard on all units	Standard on all units	Standard on all units	Standard on all units	Standard on all units	Standard on all units	Standard on all units	Standard on all units	Standard on all units	Standard on all units	Standard on all units	Not Standard
<b>Kits</b>																	
<b>Drawing</b>																	
<b>Description</b>		KIT, LAZY SUSAN, ALLOWS 180 DEG PIVOT OF MACHINE	KIT, 1/2" CROWN STAPLE GUN REPLACEMENT	KIT, TABLE HEIGHT SENSOR	KIT, SEALY GUARDS, TOP	BLACK BORDER KIT, SET OF 3 SENSORS											
<b>Price</b>																	
<b>Notes</b>		Do not Use Specific customer request	Not Standard	Do not Use Specific customer request	Do not Use Specific customer request	Do not Use Specific customer request	Do not Use Specific customer request	Do not Use Specific customer request	Do not Use Specific customer request	Do not Use Specific customer request	Do not Use Specific customer request	Do not Use Specific customer request	Do not Use Specific customer request	Do not Use Specific customer request	Do not Use Specific customer request	Do not Use Specific customer request	Do not Use Specific customer request

## Installation

### 1.4. Footprint

Machine footprint 120 x 120 inches (304 x 304 cm) Leave enough free space around to be able to open all doors and have access for maintenance.

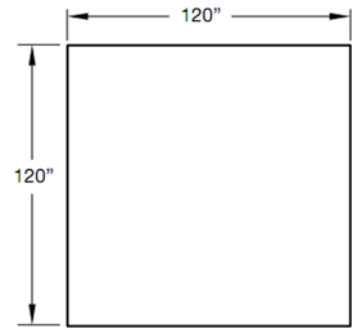

### 1.5. Machine Identification Label

Machine identification is located on top behind the table. Its contents are the machine class, technical data and the Serial Number. Ex: 208005081657

Serial number is divided as follow.

First number identify the order number 208005

Next number month of manufacturing (08)

Next number the year of manufacturing (16)

Following a correlative number 57



### 1.6. Installation & Set Up

**CAUTION: Please read all instructions prior to installing equipment. Keep in mind that the weight of this machine is approximately 2,300 lbs. (1.043 Kg.)**

#### 1.6.1. Unloading

1. Remove all shipping straps from machine.
2. Inspect the machine for any damage that may have occurred during shipping. If damage is found, report this immediately to your supervisor. Document the damage and provide details and photographs.
3. Position the machine in a desired location on a sound and reasonably level floor. Make sure that there is sufficient lighting over the machine. Remove all packing material.
4. Apply with a clean towel a light coat of oil to all black oxide parts to avoid future corrosion.

The machine is equipped with two channels (10) to allow insertion of forklift blades. Lift the machine from the shipping pallet and place in the final work area utilizing these lifting channels.

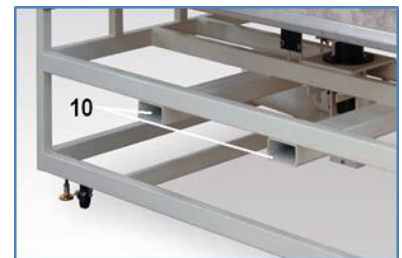

**ATTENTION: Proceed according to the policies and regulations governing proper use of forklift equipment in your plant. Do not stand or place any heavy objects on the stainless-steel table**



## Installation

### 1.6.2. Leveling

Level and adjust the machine height using the four leveling bolts (11) at the base of the machine.

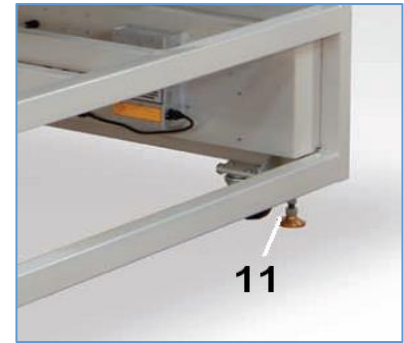

### 1.6.3. Electrical

Have a qualified electrician connect 208-230 volts, single-phase, 50/60Hz electrical power protected by a 20Amp circuit breaker to the machine. Verify proper electrical installation and grounding per local and national electrical and fire protection requirements.

**NOTE:** It is important that the green wire should be connected to earth ground.

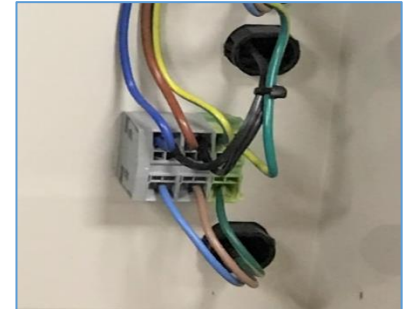

### 1.6.4. Air

Connect a ½ inch (13mm) airline supply to the main air inlet. The machine must have a minimum of 80 psi (6 bars) pressure and at least 20 SCFM supply. (0.57 m3/min)

Turn the main air lock-out valve (Red Knob before the main pressure regulator) to the “ON” position.



### 1.6.5. Cleaning

Clean the machine components of any rust preventative shipping oils in accordance to the manufacturer’s specifications.

### 1.6.6. Lubrication

The machine is normally shipped with all oils and lubricants drained. Proceed to the section on Preventive Maintenance – Weekly 40-Hour Maintenance for the location and proper adjustment of lubrication.

### 1.6.7. Power “ON”

Twist the Emergency Stop Red button “a” to return to its normal position. Turn the machine “ON” by pressing the green button “b” on the box just above the touch screen. The machine will first display the language choices and after several seconds its show the “READY-SEMIAUTO” screen. This screen is the one that the operator will always see upon power up.

**Caution: Do Not Use Any Sharp Objects to Touch the Screen**



## Installation

### 1.6.8. Electric Eyes

Turn on power. Examine all electric eyes and ensure they are all adjusted and functioning properly. See service section for instructions



### 1.6.9. Lift Table Pedal

Step on the table up / table down pedals and verify proper function.

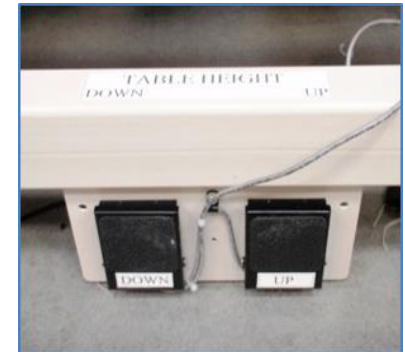

### 1.6.10. Rotary Table Foot Pedal

Step on the table up / table down pedals and verify proper function.



## 2. OPERATION

**NOTE:** It is important that the machine operator read this manual and is familiar with all the functions and safety concerns of the unit before operating.

### 2.1. Individual Components

Main

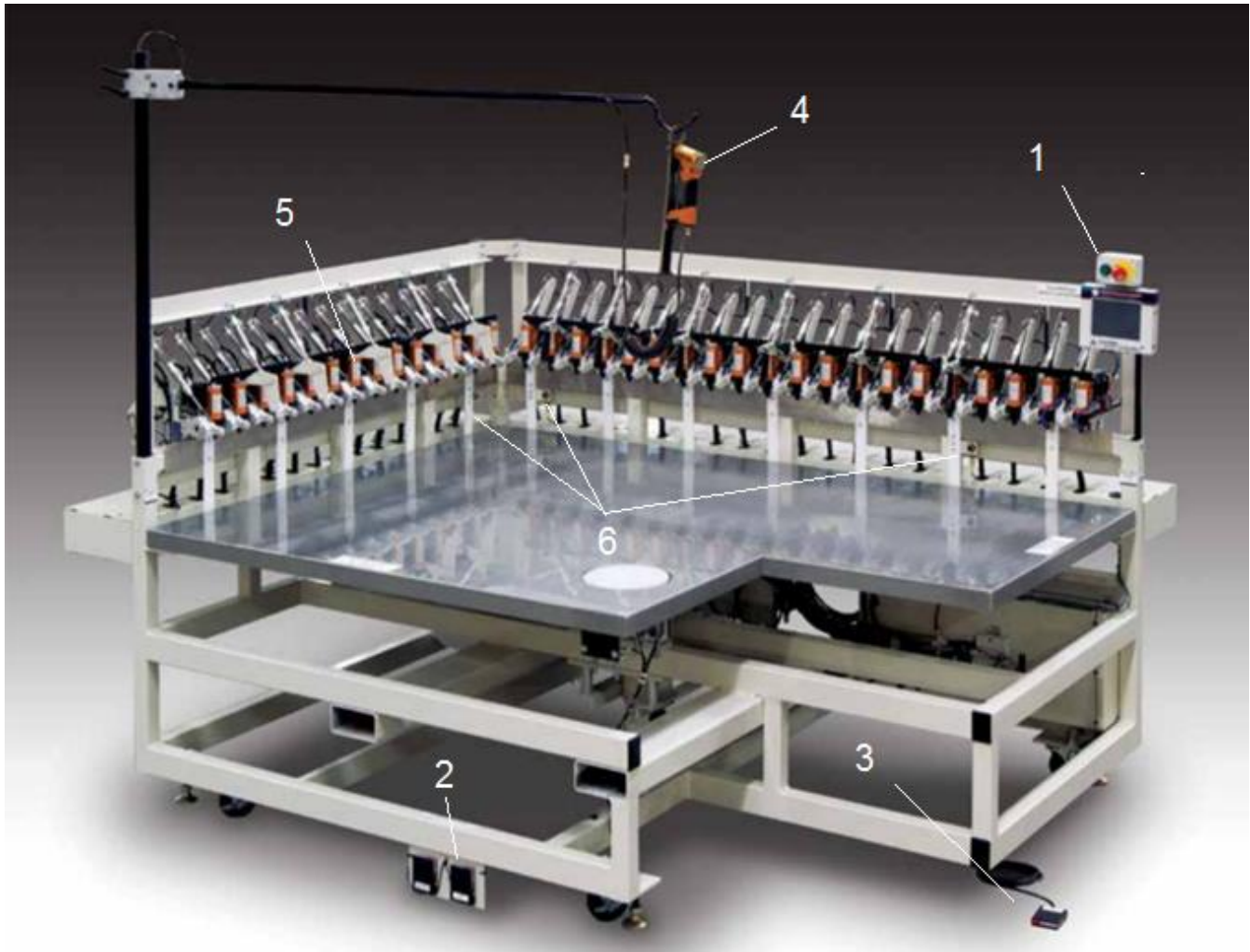

1.- Control Panel	4.- Manual Staple
2.- Table Lift Pedals	5.- Automatic Staples
3.- Rotation Plate Pedal	6.- Proximity Eye

## Operation Instructions

### 2.1.1. Control Panel

The Control Panel allows the operator to start and stop the automatic function of the machine, shut off power to the machine in the event of an emergency.

**Caution: Unlocking the button with the Power “ON” engaged will turn on power to the machine.**

#### a. Emergency Stop

Pressing this button will turn off power to the machine. This button will lock when pressed. Twisting the button will cause it to unlock and return to its normal position.

#### b. Power On

Power the machine “ON”

#### c. Serial Bus control

Controls all machine functions. More details are available in related chapters in this manual

**Caution: Do Not Use Any Sharp Objects to Touch the Screen**



### 2.1.2. Lift Table Pedals:

Pressing these pedals will raise or lower the lift table. These pedals are initially bolted to the frame but may be moved to a convenient location that is more comfortable to the operator.



### 2.1.3. Rotation Plate Pedal

This pedal raises or lowers the rotation plate. It may only be used when the machine is in training mode since the machine's controller will adjust the height during automatic cycles.



#### 2.1.4. Manual Staple

It is used to preset manually the corners of the cover or the dustcover to the wood.



#### 2.1.5. Automatic Staples

They are the one that apply the staples on the automatic process.



#### 2.1.6. Proximity Eyes

There are 3 located on the edges of the machine. Their function is to confirm that a frame is on position before starting the automatic cycle.



## 2.2. Touch-Screen

### 2.2.1. General Operation

Twist the Emergency Stop Red button “B” to return to its normal position. Turn the machine “ON” by pressing the green button “A” on the box just above the touch screen. The machine will first display the language choices and after several seconds its show the “MAIN READY” screen. This screen is the one that the operator will always see upon power up

**Caution: Do Not Use Any Sharp Objects to Touch the Screen**



#### 1. Startup Sequence

When the touch screen is powered up, the first screen displays the machine’s model information and requests that the operator choose a language.

Lightly tap on the screen button to select the desired language

**NOTE:** Lightly tap, never use a metal object or excessive force to operate the screen to prevent scratching or breakage of the glass surface

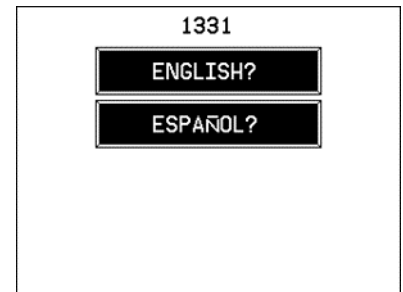

Upon receiving the operator’s language selection, the touch screen displays the OPERATION screen

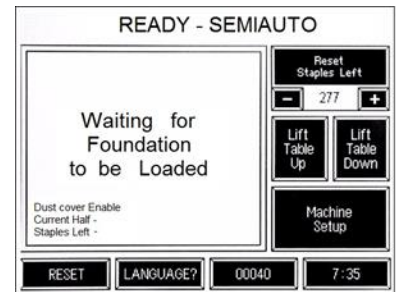

The operator accessible functions allow control of the normal production cycles and capture of production data. It also displays fault messages and guides the operator to choose the appropriate fault recovery functions. It allows the operator to adjust basic machine parameters. The graphics images presented on the touch screen show "3-dimensional" buttons, which may be pressed to access other screens, change counters and timers, or actuate hardware. Areas lacking the "3- dimensional" border contain information only.

## 2. Navigation

The row of buttons across the bottom or top of the screen are called Standard buttons. They will appear or change based on the needs of the current screen

**RESET:** Always brings the machine back to its original power up state.



**LANGUAGE:** Return to the language screen. You can select multiple languages to use.



**PIECE COUNT:** The field on the left of the clock button is the piece counter that increases every time the border cycle is complete. Touching this area will bring up a screen to reset this count. This counter can be used for a daily production monitor, also located on this screen is an efficiency monitor that displays the machine run time vs. the machine on time and displays it as a percentage.



**CLOCK:** Lower right button allows access to a screen for setting the correct time. While on the Main Screen it allows you to set the time and date. On all other screens it is a display only.

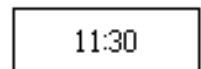

**HOME:** Leaves the current screen and takes you to an appropriate screen (usually to the main operating screen). Return to the main screen



**EXIT:** Leaves the current screen and takes you to an appropriate screen (usually back one level or to the previous screen you were on).



**CONTINUE:** Used to restart an event or function that has been temporarily paused or suspended.

Others buttons are localized on top of or inside the screen

**ARROWS:** Pressing the arrows right or left will take you to the next or previous pages.



**COUNTERS:** Are identified with the "+" and "-" buttons in the corners. These counters may be adjusted by touching the "+" and "-" boxes.

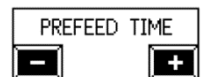

**NOTE:** When a button has a white background, the function is "ON" or enabled. A dark background indicates off or disabled. Some buttons may toggle ON or OFF, others must be held in the ON state.

Other screens display whenever there is a machine error or other condition that prohibits the operation of the machine. Simply follow the instruction on the screens to resolve the problem.

There are also advanced settings and advance functions available. These functions are only accessible by a password, and include timers that control machine hardware, input and output test screens, and machine statistics. To get to the advanced functions the appropriate password must be entered at the security screen. Security access is reset whenever the main power is turned off, or the RESET button on the main page is pressed.

## Operation Instructions

### 2.2.2. Available Menus

The following is a summary of the different screens and their functions available for the Operator.

#### 1. READY SEMI-AUTOMATIC.

This screen is the main operating screen. The entire cycle of clamping, table lifting, material tensioning, stapling and rotary plate lifting are sequenced automatically by the computer

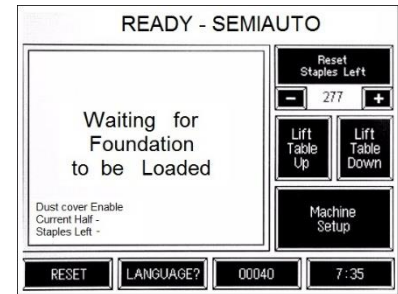

#### 2. READY- TRAINING:

The machine will cycle through the following sequences: CLAMP, LIFT TABLE, STRETCH MATERIAL and hold.



#### 3. PAUSED:

The operator must tap on this screen to continue the staple cycle. This screen only appears while in TRAINING mode.



#### 4. STAPLING FOUNDATION.

The operator must tap on this screen to stop the automatic staple cycle.



#### 5. PIECE COUNTER.

This screen displays production data including time, piece counts, efficiency, etc. The screen includes a count RESET button which zeros out the production counters.

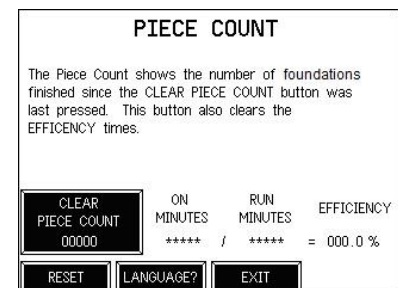

## Operation Instructions

### 2.2.3. Set up Screen

From the Semiautomatic Screen, the operator may adjust various machine parameters by tapping the button [SET UP]. Some adjustments may be restricted and require a security password to allow changes.

#### 1. Reset Staple Left

Returns the remaining staple count to the maximum value. The maximum value may be increased or decreased using the buttons labeled “+” or “-”

#### 2. SHOW ALL SETTINGS

This button moves to a screen that displays all current machine adjustments.

#### 3. SYSTEM INFORMATION:

Displays general machine information including software version.

#### 4. SECURITY

This screen is used to change key codes. It is recommended that the key codes be stored in a safe area.

#### 5. ADVANCED ADJUSTMENTS

This button will open the Technician’s Adjustment Screen. Proceed to the TECHNICAL MANUAL for a detailed explanation of this area.

#### 6. CONTRAST

Adjust the brightness of the screen. Please note: the screen becomes brighter after warming up. Allow at least 5 minutes prior to making any brightness adjustments.

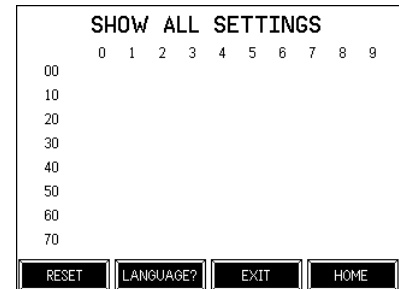
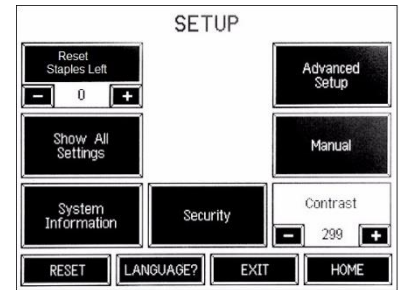

## Operation Instructions

### 2.3. Operation Description

The machine has been designed to perform two main functions:

- A. Tension the sides of the Foundation and staple it to the wood border.
- B. Attach the dust cover using staples to the Foundation wooden frame.

These operations may be performed individually or sequentially depending on the program selected.

#### 2.3.1. Foundation Edge Stapling Cycle

**NOTE:** Be sure that the touch screen displays READY \_SEMAUTO, Dust cover Disable and the “CURRENT SIDE” displays “1”

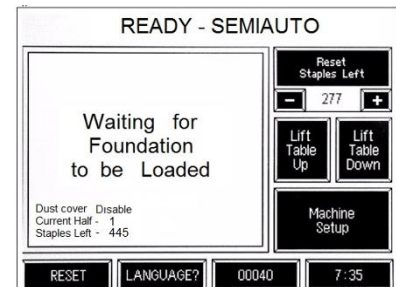

- A. Handling the Foundation by the corner, press against the two machine edge guides making sure that the three load sensors are activated.

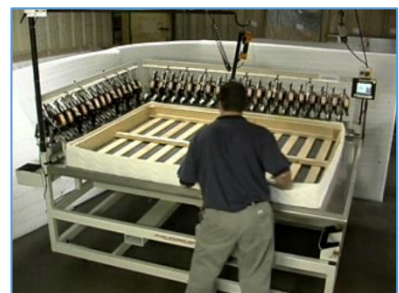

- B. The machine will automatically activate the Border Clamps which will press the Foundation against the machine's sides, the tension wheels will lower, and the table will rise.
- C. After activation the tension wheels will stretch the material. Next the stapler guns will activate securing the border to the wooden frame.



- D. The Foundation will be unclamped, and the rotation table will rise allowing the operator the opportunity to rotate the unit to the next side. The computer touch screen will then display “CURRENT SIDE 2”



- E. The previous cycle will repeat stapling the other edges of the Foundation
- F. Remove the unit from the machine and insert a new Foundation.



## Operation Instructions

### 2.3.2. Dust Cover Stapling Cycle

To use this cycle, the option [Enable Dustcover] in the Advanced Options Screen (Screen #8) must be in position 1. When activated the touch screen displays READY-SEMAUTO Mode ARMED and that the "CURRENT SIDE" is displaying a "1"

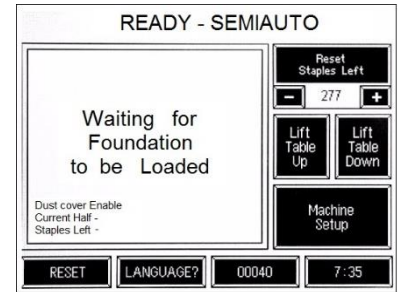

- A. Handling the Foundation by the corner, press against the two machine edge guides making sure that the three load sensors are activated. The machine will automatically activate the Border Clamps which will press the Foundation against the machine's sides, the tension wheels will lower, and the table will rise. After activation the tension wheels will stretch the material. The staple guns will activate securing the border to the wooden frame.
- B. The Foundation will be unclamped, and the rotation table will rise allowing the operator the opportunity to rotate the unit to the next side. The computer touch screen will then display "CURRENT SIDE 2".
- C. The previous cycle will repeat stapling the other edge of the Foundation. While the machine is stapling side 2, take a dustcover and begin securing its corners to the wooden frame using the manual stapler.
- D. After the second stapling cycle finishes, the machine will advance to the "CURRENT SIDE 3". Try to align and stretch the dust guard as much as possible to prevent tangling in the machine and having an insufficient area to staple.
- E. Turn the Foundation push it back into the machine. This time only the staplers will activate.



## Operation Instructions

F. While the machine is performing “SIDE 3”, begin securing the dust guard corners to the wooden frame using the manual stapler. Try to align and stretch the dust guard as much as possible to prevent tangling in the machine and having insufficient area to staple.



G. After the third stapling cycle is complete, the machine will advance to “SIDE 4”. Turn the Foundation or push it back into the machine. Once again only the staplers will activate

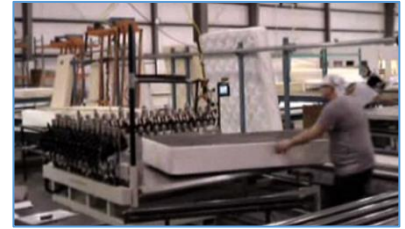

H. Once the machine completes the fourth sequence, remove the Foundation from the machine. The computer touch screen will automatically return to “SIDE 1”



### 2.3.3. Reloading the Staplers.

**Caution: be sure that the machine power is off before initiating this procedure. If the power is not removed, the stapler may discharge a staple**

A. Pull the two security pins from the Stapler Block and rotate  $\frac{1}{4}$  turn until it unlocks from the block.

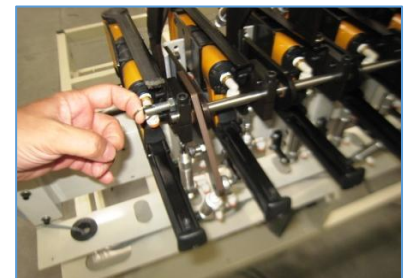

B. Lift the Stapler Block and rotate 180-degrees. (Fig 2)



C. Perform the same operation on the remaining Stapler Blocks.



## Operation Instructions

D. Squeeze the locking lever on the Stapler magazine and open the stapler compartment.

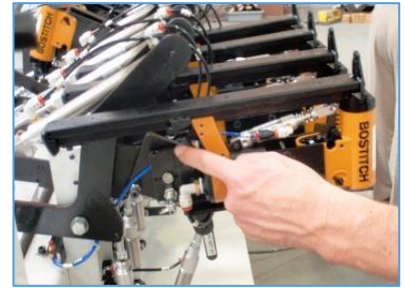

E. Introduce a new strip of staples into all of the staplers. Depending on the usage, the staplers on the ends may have sufficient staples. Add more staples as required.



**NOTE:** The machine uses the following types of staples:

# Part	Description
BA-7110	STAPLE, 3/8"LF OR TU21671LM 3/8 CROWN, 25000/BOX
BA-7112	STAPLE, 1/2"LF OR TU21671LM 3/8 CROWN, 25000/BOX

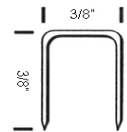

F. Close the staple compartment until the magazine's locking lever is secured in the LOCK position. Return all staplers back to their operating positions.

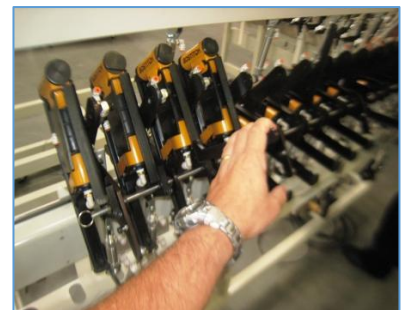

G. Rotate the security pins ¼ turn until they snap back into the LOCK position. Repeat this task on the remaining stapler blocks. Verify that all of the staplers are properly LOCKED and that their magazines are properly LOCKED.



**NOTE:** Be carefully do not to drop the guns damaging the pins

H. Turn the machine back ON and initialize the touch screen's Remaining Stapler Counter

## Maintenance

It is important that the machine operator read this manual and is familiar with all the functions and safety concerns of the unit before operating.

### 2.3.4. General Safety Instructions

Maintenance should only be performed by trained, qualified personnel. Before performing any maintenance or repair work, switch off the electrical, pneumatic, etc. power to the machine at the main source and secure it with a padlock so that it cannot be switched on again without authorization. Refer to lockout/tag out procedures



- Always wear proper safety equipment when operating or performing maintenance on any equipment.
- All recommended maintenance is for a single shift schedule; adjust as necessary for a multi-shift operation.
- Equipment should not be used for purposes other than designed or specified.
- The machine shall be switched off, come to a standstill, and be secured so that it cannot be switched on again inadvertently before starting any maintenance work whatsoever.
- Use proper lockout/tag out procedures to secure the machine against inadvertent startup.
- Remove any oil, grease, dirt, and waste from the machine, particularly from the connections and screws, when starting the maintenance and/or repair work.
- Do not use any corrosive-cleaning agents.
- Use lint-free rags.
- Retighten all screw connections that have to be loosened for the maintenance and repair work.
- Any safety mechanisms that have to be dismantled for setting-up, maintenance or repair purposes must be refitted and checked immediately after completing the work

2.3.5. Preventive Maintenance 8 Hrs.

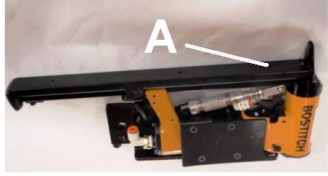
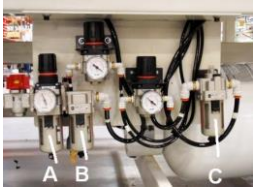

# Preventive Maintenance 8 Hrs

<b>Model:</b>	1331 Series	<b>Required Materials</b>
<b>Serial #:</b>		
<b>Operation:</b>	Stapler	
<b>Serial #:</b>		
<b>Serial #:</b>		

<b>Before starting the day's shift with "The Machine Off"</b>	
Add one drop of lubricant in the stapler magazine A prior to the start of each work shift.	
Check the state of air filters "A" and "B". Drain water if necessary..	
Check the level of the lubricant in bowl "C". Notify the maintenance technician if necessary	
Clean the machine of any dust or dirt that has accumulated	
<b>After a day's shift with "The Machine Off"</b>	
Clean the machine of any dust or dirt that has accumulated	
Check for thread accumulation on tension wheels and the moving parts	
Cover the machine and notify the supervisor of any unusual noise or abnormality that is present during the working shift	

### 3. SERVICE

**NOTE:** Maintenance should only be performed by trained, qualified personnel.

#### 3.1. Lockout/Tagout Program

"Lockout/Tagout (LOTO)" refers to specific practices and procedures to safeguard employees from the unexpected energization or startup of machinery and equipment, or the release of hazardous energy during service or maintenance activities. This requires that a designated individual turns off and disconnects the machinery or equipment from its energy source(s) before performing service or maintenance and that the authorized employee(s) either lock or tag the energy-isolating device(s) to prevent the release of hazardous energy and take steps to verify that the energy has been isolated effectively. The following references provide information about the LOTO process.

Equipment Energy Control Procedure Lockout/Tagout Program				
Description: <b>Bottom Hemmer</b>		Model: <b>1331 SERIES</b>		
Manufacturer: <b>Atlanta Attachment Co.</b>		Location:		
Energy		Location	Magnitude	Control Method
Electrical:	X	Disconnect/Ctrl Box	<b>220V</b>	Lockout & Tag
Pneumatic:	X	Main Regulator	<b>90 PSI</b>	Lockout & Tag
Gravity:	X	Staplers, Clamps		
Remember to Release All Stored Energy!				
<b>Shutdown Procedure:</b>				
Inform all affected personnel that the machine will be in Lockout status. Turn the power and pneumatic disconnects to the OFF position. Fill out the tag with necessary information of the Lockout. Install the Lockout device. Verify all stored electrical energy has been released by pressing the power on button. Also, use meter to test circuits in the electrical panel to insure stored energy is released there as well. Perform necessary maintenance, services and/or repairs.				
<b>Startup Procedure:</b>				
Inform all affected personnel that the Lockout of this machine is being removed. Replace any guards or safety devices which may have been removed during maintenance. Remove the Lockout device and tag. Turn the power and pneumatic disconnects to the ON position. Push the green button on the back of the control panel to turn the machine on. Inform all affected personnel that the Lockout has been removed and that the machine is ready for normal production operation.				

Approved By: \_\_\_\_\_

Date: \_\_\_\_\_

### 3.2. Operation Sequence.

A. The operator introduces a Foundation into the machine until the load sensors “A” on the sides of the machine are activated.

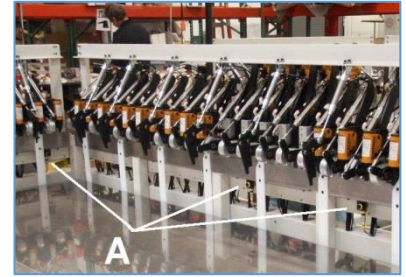

B. The tension wheels lower, the clamps lower, and the table begins the raising sequence.



C. At the moment the Foundation touches the tension wheels, the travel sensor “B” detects and halts the table from raising any further.

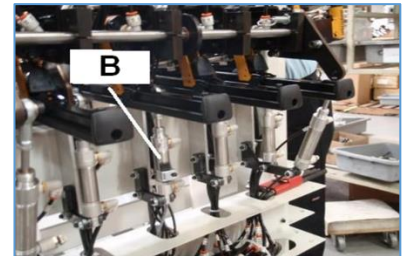

D. The clamp sequence begins followed by the tensioning sequence.



E. After finishing the tension sequence, the staplers are activated.



F. The clamp, tension and staplers return to their initial position. The rotary plate lift up, allowing the operator to turn the Foundation to the other side.



G. The table returns automatically to the last stapler position.

H. The operator repeats the cycle.

### 3.3. Mechanical Adjustments

#### 3.3.1. Table

##### 1. Column Lift

**Rule:** The square table column has a lift height of 6 inches (15.24 cm). With time and usage, there may be wearing of the interior Teflon guides that support it and this may present problems at the moment of stretching or stapling the Foundation material. If the table begins to show signs of wear, then readjustment may be necessary.

**Adjustment:** Raise the table to its maximum height; loosen the nuts of the eight adjustment bolts “A”. Loosen the upper four bolts “A” and the lower four bolts “B” of the Teflon support bars.

Lower the table to its lowest height. Lightly tighten the eight bolts “A” which decrease the areas of wear within the assembly. Raise and lower the table using the appropriate pedal to verify that the table moves freely. Adjust the bolts “A” again until the play in the table is as little as possible without binding the lift motor in its raised or lowering directions. Tighten the eight nuts of bolts “A” and the eight bolts “B” of the Teflon support bars.

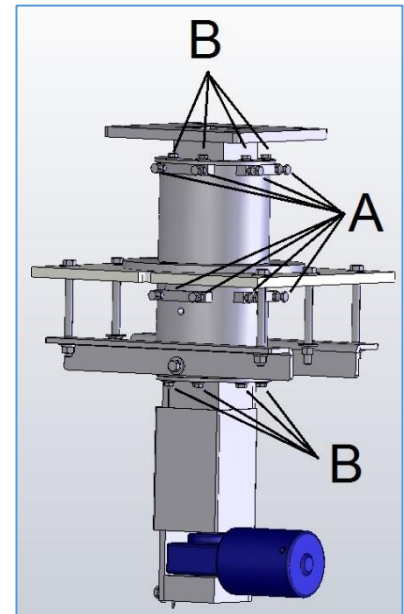

##### 2. Alignment and Leveling

**Rule:** The table should be aligned and leveled with respect to the machine’s frame.

**Adjustment:** Loosen the four bolts that support the table to the column lift “C” and rotate the table until it is square with the machine’s frame. If necessary, introduce shims under the table to realize the best parallelism as possible.

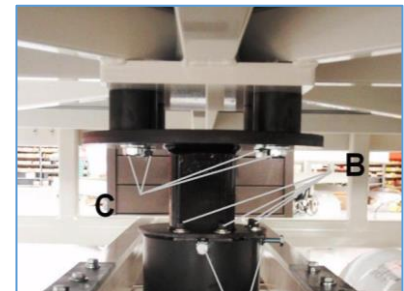

Once you are square and parallel with the machine’s frame, secure the two stabilizers (white plastic) blocks underneath the corners of the table to lightly touch the machine frame.



#### 3.3.2. Tension Wheel

##### 1. Movement

**Rule:** The components and movement of the tension wheels should move freely but with no play.

In the activated position, the bottom of the tension wheels should be at the same height as the stainless-steel bar “A” used as the Foundation stop.

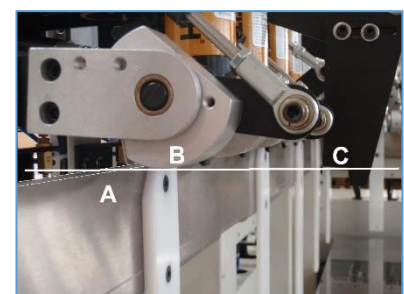

## Service Instructions

**Adjustment:** Readjust all of the motion components of the tension wheels. Loosen the bolts on cylinders “A” and adjust the heights to comply with the rule.

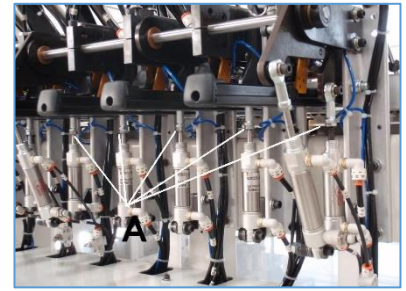

### 2. Rotation

3.3.the material sufficiently to maintain adequate tension.

**Adjustment:** Adjust the stop rings on the tension wheel cylinders to measure 2.5 inches (6.35mm) as shown.



### 3. Lower Position

**Rule:** The table has a sensor to detect the material “A” that activates during the automatic cycles. The sensor should be activated when the tension wheel cylinder is fully extended and deactivated at 1/16 inch (2mm) on the cylinder return stroke.

**Adjustment:** Loosen the sensor and move to the recommended height.

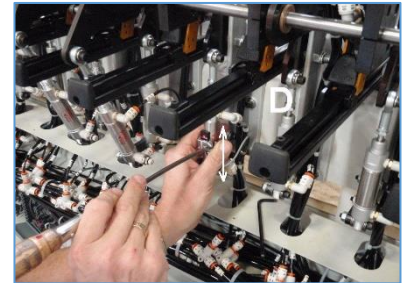

#### 3.3.3. Border Clamp Fingers

**Rule:** The position of the fingers depends on the structure of the Foundation. The function is to maintain the frame against the machine nylon stops. The clamp arms should only hold the Foundation. It should never sink in. There are many variations of clamp fingers, and they may be modified to fit the profile of the wooden frame of the Foundation.

**Adjustment:** Lower the border clamp fingers, loosen the bolts “A” and position the fingers in the correct location. Generally the lateral arms are located in a different manner than those of the head border. Upon activation, the clamp arms should press the Foundation against the feed stops.

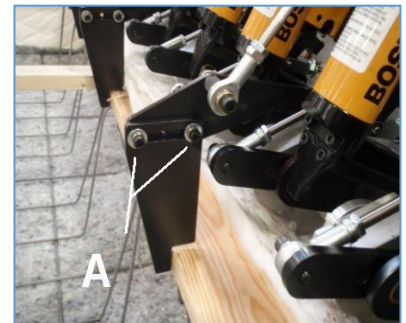

#### 3.3.4. Staplers.

##### 1. Height

**Rule:** The components and movement of the staplers should be free with no play.

Assuming that the table has been leveled and aligned with respect to the machine (see table adjustment) and the staplers are all in the firing position, then all of the stapler’s end points should be at the same height with respect to the table.

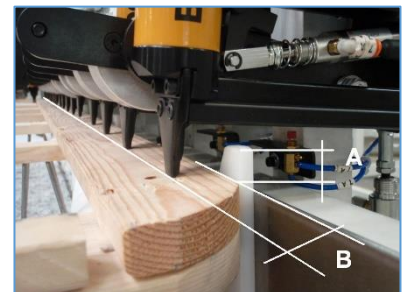

## Service Instructions

**Adjustment:** Introduce a Foundation frame into the machine and raise it until the distance “A” is 1/2 inch. (12.7mm)

With the staplers located in their firing position, loosen the bolts on the activation cylinder shafts “D” and adjust the shaft until the exterior staplers rest on the wooden frame of the Foundation. Next, loosen the supports of the three staplers “C” and rest them on the wood as shown in the previous image interior. Tighten all of the bolts in this group and proceed to the next group until all of the staplers are at the same height. Remove the Foundation and verify that all of the staplers are at the same height.

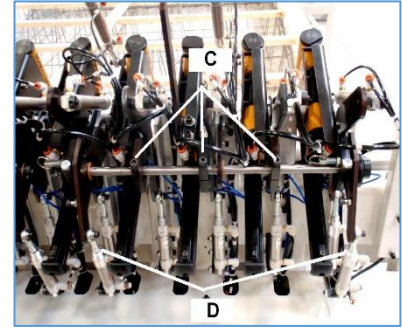

**NOTE:** This should be checked weekly, as movement may occur, if guns assembly clips are not gently lowered back into position after staple loading

### 2. Position

**Rule:** The staples have been factory adjusted to ½ inch (12.7 mm) from the edge of the Foundation wooden frame (“B” in the previous image). The final position of the staples with respect to the Foundation’s wooden border will depend on the customer’s requirements.

**Adjustment:** The adjustment may be performed using two different methods

a. - Modifying the distance “E” from the stainless-steel bar used as a stop for the Foundation sides and the machine’s frame. To perform this method, loosen the bolts supporting the stainless-steel bar underneath the machine.

b. - Modifying the distance “G” from the stapler support and the machine’s frame. To perform this method, loosen the bolts “F” and move until you achieve the required position.

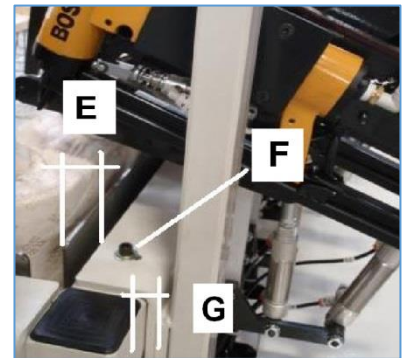

### 3. Firing Cylinder

**Rule:** The stapler should fire with sufficient speed and enough force for so that the staples penetrate deeply and securely into the wood.

**Adjustment:** The stapler has an adjustment lever that controls the flow of air into the cylinder “A”. Move this lever toward the Maximum position (+)

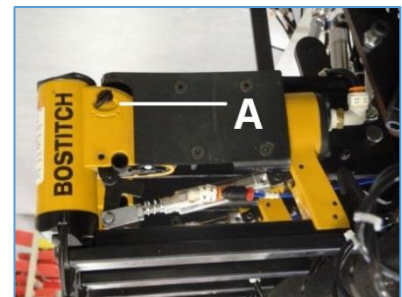

### 4. Bypass Valve

If there is not a foundation under this stapler, it will not fire when activated. This prevent staples from being fired unnecessary



### 3.4. Pneumatic

**NOTE:** All maintenance should be performed by a qualified service technician.

#### 3.4.1. Air Maintenance Unit FRL

The FR (Filter Regulator).unit assembly is located behind the table. It has 3 components the Pressure Relief Valve **(A)** , the Pressure Regulator **(B)** and the Air Filters **(C)**. This unit do not require an Air lubricator

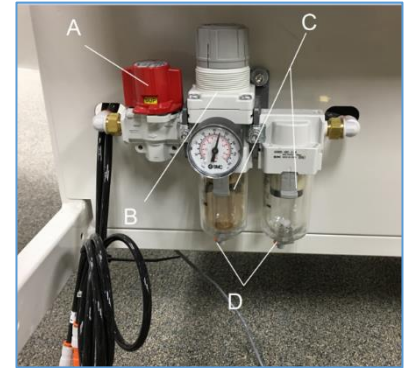

#### 1. Pressure Relief Valve

Single action operation with a simple turn. It isolates the supplied pressure in the pneumatic system and exhaust downstream pressure for maintenance purposes. The unit can be locked in the exhaust position. Air flow direction is easily identified by handle orientation and labeling. It is part of the FR



#### 2. Pressure Regulator

The purpose of the regulator is to keep the operating pressure of the system (secondary pressure) virtually constant regardless of fluctuations in the line pressure (primary pressure) and the air consumption.



#### 3. Air Filters

Clean air from your compressed air system is essential for the safe and efficient operation of this equipment. This unit has 2 compressed air filters. They remove contamination from compressed air after compression has taken place. Harmful contaminants like oil, dust, dirt, rust, and water-alone or in combination-can attack your system and clog sensitive pneumatic parts.

- It can reduce the efficiency of the unit.
- Wear out seals and erode system components.
- Increase maintenance and repair costs.

Air leaving a standard screw or piston compressor will generally have a high-water content, as well as a high concentration of oil and other contaminants.

Condensate is drained manually by pushing the red bottom on the drain plug **(D)**. They require a regular maintenance schedule (i.e., once per shift).



#### 4. Air Lubricator

Injects an aerosolized stream of oil into an airline to provide lubrication to the internal working parts of pneumatic tools, and to other devices such as actuating cylinders, valves staples, etc.

It should inject one drop of oil every 10 cycles.



## Service Instructions

### 3.4.2. Solenoid Valve Stacking Manifold

They are located inside the control box

Control System voltage 24DC

Each valve can be activated manually by pushing the blue bottom.

Red light means the valve is energized

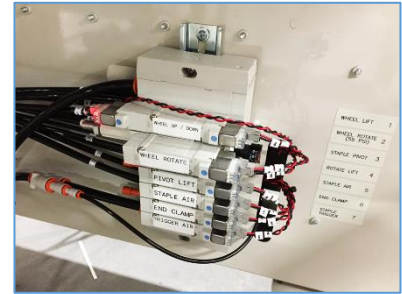

### 3.4.3. Pressures Adjustments

The machine has four pressure regulators.

1. - Regulator "A" Controls the main pressure entering the machine. This pressure should be adjusted to 80 psi (6 Bar) and should not decrease during machine operations. Should this happen then the air supply to the machine does not have sufficient capacity to run this machine.

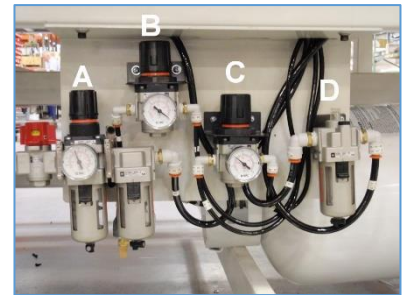

2. - Regulator "B" Low Pressure for the Tension Wheel Down. Controls the force applied by the cylinder to the tension wheels at the moment of rotation.

If the pressure is set too high, then material damage may occur, and the fingers may embed themselves into the wooden frame of the Foundation. If the pressure is too low, then the tension wheels may slip while tensioning and may leave the material too loose. Factory setting 5-15 Psi (0.35 – 1 Bar)

3. - Regulator "C" High Pressure for the Tension Wheel Down. Controls the force applied by the cylinder to the tension wheels down and up. Factory setting 30-40 psi (2 - 2.7 bar)

4. - Pressure Regulator "G" for the rotation of the tension wheels. The regulator is found in the wiring control cabinet at the rear of the machine. The factory setting is 55 psi. (3.8 bar)

If the pressure is too high, then the border may be excessively stretched, or the foundation may be pushed so hard that the end clamps cannot hold the foundation in. If the air pressure is too low, the material will not pull tight or will stay too loose or baggy. In the case of box spring Foundation, the Foundation will be flattened and in the case of material that does not stretch, this may cause a tear in that material.

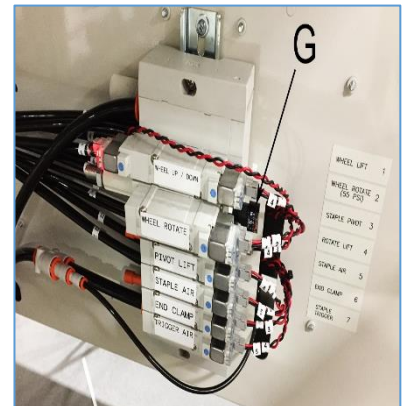

### 3.4.4. Air Pressure Switch.

It is located inside the control box. This Sensor responsible for the detection of the secondary air pressure if it does not reach the pre-adjusted value. Connected to module #5 on the Serial bus system. For more details of connections see plumbing diagram located at the ends of the Spare Parts Book.



## 3.5. Electrical

**NOTE:** All maintenance should be performed by a qualified service technician.

### 3.5.1. Ground

This unit needs to be connected to ground (earth) for several reasons. In main powered equipment, exposed metal parts are connected to ground to prevent user contact with dangerous voltage when electrical insulation fails. In electrical power distribution systems, a protective ground conductor is an essential part of the safety Earthing system. Connection to ground also limits the build-up of static electricity



### 3.5.2. Main Circuit Breaker

The main power On/Off switch is on the inside of the control Panel. It is used to turn the power on to the whole machine. This machine requires 220V Single Phase. If you have problems with the power not coming on when the ON button is pressed you may check this switch by doing the following.

**ATTENTION.** Make sure that the machine is unplugged before proceeding and that all lock out/tag out procedures have been correctly followed (See to Lockout tag out procedure)



### 3.5.3. Main Power Contactor

When you press the green button, it activates the contactor to turn on the power to the machine. It also functions to protect the unit after a power failure. It will keep the machine without power until the green START button is pressed.



### 3.5.4. Photoelectric Sensors

All three sensors have to detect the foundation to properly activate the staplers.

**Rule:** All 3 sensors need to be activated when a foundation is set against the 2 edge plates

**Adjustment:** The proximity range can be set intuitively via potentiometer. Light-on or dark-on mode is selected via rotary switch. Check at the control panel the activation of each individual sensor



### 3.5.5 Settings

#### Set the output function

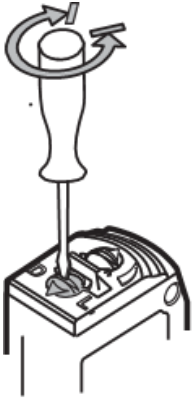

- Setting **D** dark-on mode
- Setting **L** light-on mode



#### Set the range

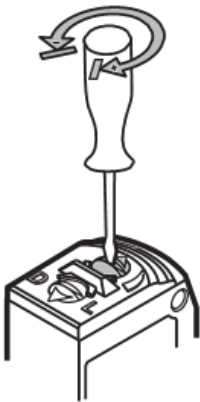

- Increase range: turn the setting screw of the potentiometer clockwise.
- Decrease range: turn the setting screw of the potentiometer counter-clockwise



Objects that are beyond these set switch point are suppressed.

#### Operation

- ▶ Check whether the unit operates correctly.
  - > The green LED is lit when the supply voltage is applied, and the sensor signal is stable.
  - > **Dark-on mode:** the output is switched / the yellow LED is lit when no object is detected.
  - > **Light-on mode:** the output is switched / the yellow LED is lit when an object is detected.

## Service Instructions

### 3.5.6. Signal Output Verification of Sensors

Turn on the machine and press MACHINE/MANUAL



MACHINE

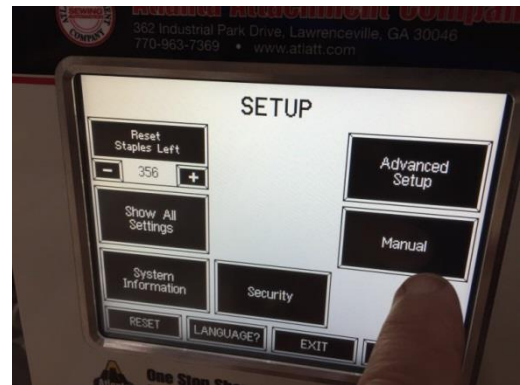

MANUAL



SECURITY CODE

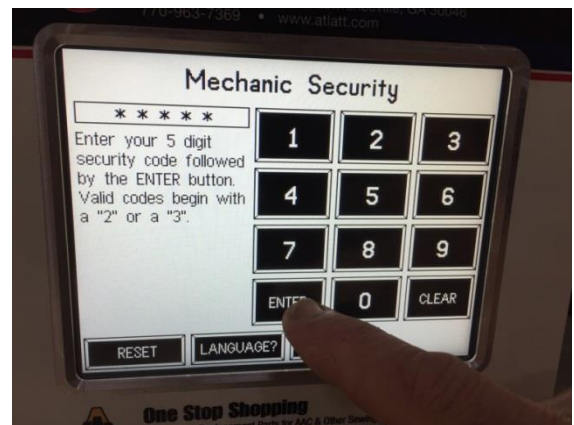

ENTER

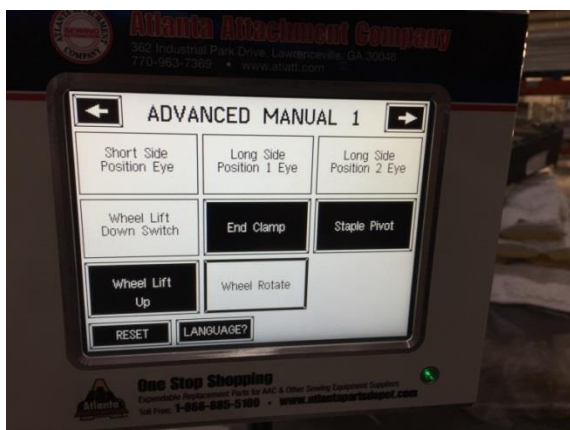

SENSOR VERIFICATION

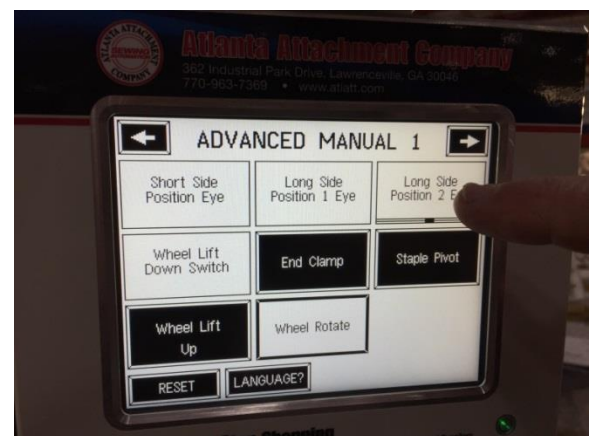

SENSOR CONFIRMATION

### 3.6. Serial Bus

The Serial Bus System, based on only four wires, is self-diagnostic and offers helpful solutions to solve the problem. An operator using a touch screen control panel manages this rugged, uncomplicated system. Designed to international standards, this multi-lingual, easy to operate interface will allow parameters to be saved, allow technician access with password protection, and offers a built-in production performance monitor which can be networked to a central computer.

A warranty of 3-Years covers all electrical components of the state-of-the-art Serial Bus Control. Controller part number is 4080-004



#### 3.6.6. Touch Screen

**Caution: Do Not Use Any Sharp Objects To Touch The Screen**

##### 1. Calibration

If you are having troubles locating the right place to get access to the function by touching the screen a screen calibration may be required.

Proceed as following:

- A. Place one finger on the screen and hold it there while pushing the Green ON button.



- B. When the screen turns light, remove your finger and the screen will display two lines, one vertical and one horizontal, intersecting at the top left corner. The text “Touch at the crossed lines to calibrate display.” should appear in various languages. In older machines, there will be no text. Using a small pointing device that will not puncture or damage the screen (such as a pencil eraser), touch the screen where the two lines intersect. Do this with as much accuracy as possible.

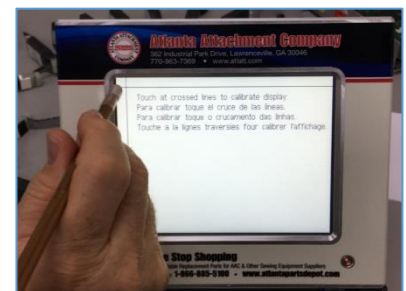

## Service Instructions

- C. When the screen is touched, the display will change to two lines intersecting at the lower right of the screen **NOTE:**

**The implementation of step 2 and step 3 directly affects the validity of all the buttons in the entire program. It is very important to be accurate.**

- D. . Repeat step 2 where these lines intersect

- E. . On 004 screen all 4 corners need to be adjusted

- F. Press the language button of your choice.

- G. Press the RESET button at the lower left corner of the screen. See figure.

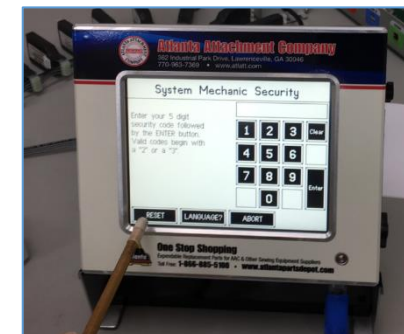
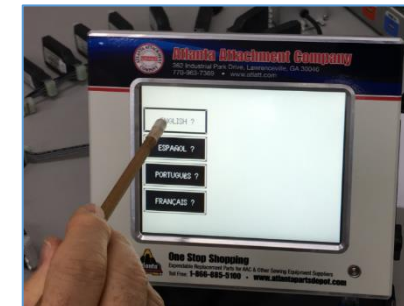
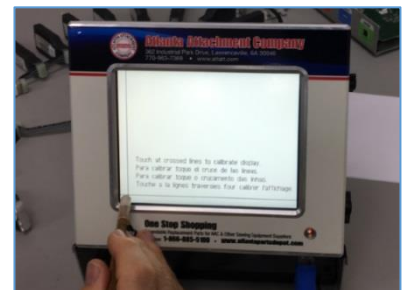
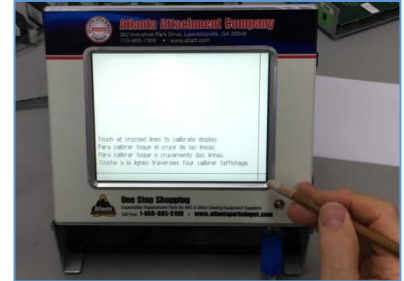
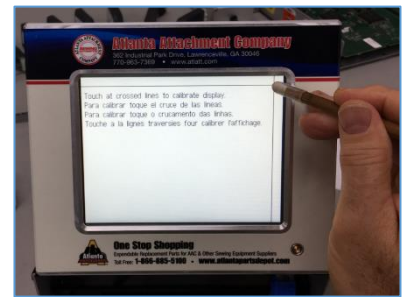

## 2. Installing New Screen

To install new screen you must follow these directions.

- Install new screen and turn power on
- When screen displays "Fatal Error Message" press continue
- Enter Mechanic Security Code
- After reading the "Warning Message" press continue again

## Service Instructions

---

- E. Screen will begin to process the up-loading of existing program. This will take 60 - 90 seconds
- F. After reading the "Last Warning Message" press continue again.
- G. Screen will begin to process information again for 15 - 30 seconds
- H. Reset routine will follow.
- I. **NOTE** Machine assemblies will reset or move to home positions
- J. Screen will return to the Main Display and is ready to run.

### 3.6.7. Modules

#### 1. Standard Modules

##### A. Program Module...4080-150

Stores the program information. It is also used to load program modifications or updates. For update procedures please refer to the next chapter.



##### B. Data Module...4080-930

Stores the unique data required to operate this particular machine; such as serial number, original factory parameters, etc. This module should never be exchanged with another machine.



##### C. Output Module...4080-140

Responsible for transferring signals from the computer to the working elements such as valves, motors and relays, etc.



##### D. Input Module...4080-110

Responsible for transferring signals from the machine to the computer such as switches, electric eyes, sensors, etc.

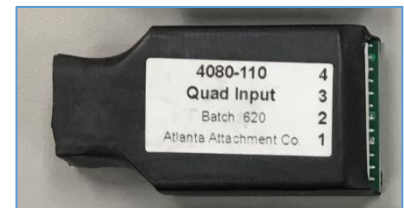

##### E. Air Pressure Module...4080-200

Responsible for monitoring the air pressure of the machine. If it falls below a specific level, it will shut the machine off.



#### 2. Replacing a Module

**NOTE:** Even though all output and/or input modules within the machine are identical, they cannot be moved to another location on the serial bus cable, as the computer automatically assigns a working address for each one.

If a replacement is necessary, always replace with a new or loaner module from another machine.

Electrical Power to the machine must be turned "OFF" during replacements.

Computer will show an error if one or more modules are missing.

Removing more than 1 module at a time will require reinstalling all of the modules



#### Procedure:

Remove the old module and connect the new one, after turning on the power, the computer will reassign the address to this new module.

### 3.6.8. Program Update

**NOTE: Very Important**

Before starting the procedure below, go to Advanced Settings and write down all the settings shown in these screens.

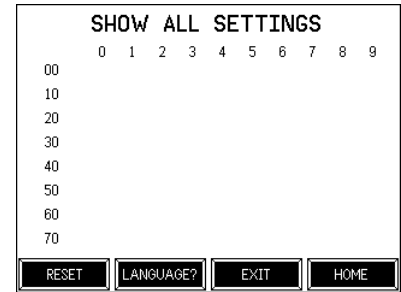

1. Turn off power to the machine.
2. Replace the existing Program Module with the Program Module that contains the updated program.



3. With your finger on the screen, turn power on to the machine. When the screen changes from dark to light, remove your finger from the screen.



4. Carefully calibrate the screen. See screen calibration chapter.

**ATTENTION: Do not turn off the machine during this process for any reason, as vital information will be corrupted, and it will be necessary to call manufacturer for assistance and/or return the touch screen and module for base programming.**

5. Press the “Update Controller” button. Input mechanic security code (22222). This process takes up to 5 minutes and asks you to press the “Continue” button once during this time.
6. When complete the Controller will contain the updated program.

**NOTE:** Continue to item 7 only if you need to reprogram original module.

7. Turn off power to the machine.
8. Replace the Program Module that you installed in step #2 with the original Program Module that came with the machine.
9. With your finger on the screen, turn power on to the machine. When the screen changes from dark to light, remove your finger from the screen.
10. Carefully calibrate the screen.
11. Press the “Update Program Mod” button. Input technician security code (22222). This process takes up to 5 minutes. When complete the original Program Module that came with the machine and the Controller will contain the updated program.

Now that the process is complete, go to Advanced Settings and verify them using the settings you wrote down at the beginning of the process. Make any necessary correction

## Service Instructions

### 3.6.9. Expiration Count 911

Expiration Count Code “911” is not an error that can resolved without assistance from Atlanta Attachment.

- Machine has displayed this error as the result of someone removing or installing modules incorrectly.
- Machine has completed a predetermined time-cycle set by the factory.

When contacting Atlanta Attachment via phone or e-mail, please provide this information below, as displayed on the “911” screen

- The machine type
- The machine serial number
- The security key
- The master clock

Here is what the 911 warning currently says:

#### Warning 911 Instructions

1. Contact the Atlanta Attachment Company Service Department (USA).

Phone: +1 (770) 963-7369

Fax: +1 (770) 963-7641

Email: techsupport@atlatt.com

2. Once in contact, provide the following information.

000 Machine Type  
000000000000 Machine Serial Number  
00000 Security Key  
0000000000 Master Clock

To TEMPORARILY bypass this warning, press CONTINUE

#### 1. Unlock Procedure

1. Power up the machine while pressing the center of the screen with your finger.
2. Once the screen becomes white, remove your finger and two lines should appear crossing in the upper left corner of the screen.
3. Calibrate the touch screen by pressing where the lines cross with the tip of your finger.
4. Two other lines should appear crossing in the lower right corner of the screen.
5. Calibrate the touch screen by pressing where the lines cross with the tip of your finger.
6. A language selection menu should now appear.

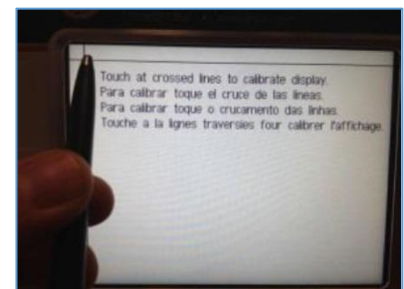

7. A MECHANIC SECURITY SCREEN should appear. Type your 5-digit security code

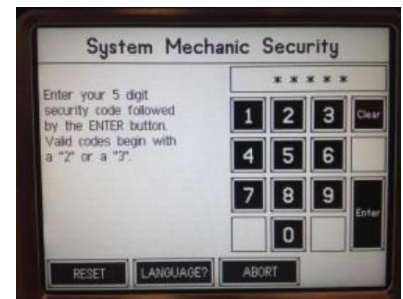

8. The Controller Setup show up; press continue



9. In the screen CONFIG UTILITIES, press EXP CODE.

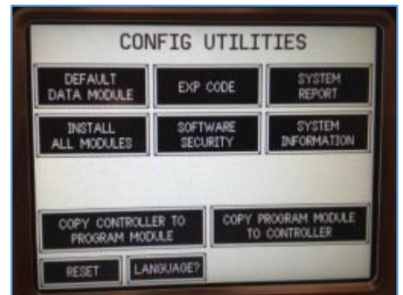

10. Report the three numbers at the top to the AAC Service department staff.

- A. The machine type
- B. The machine serial number
- C. The security key

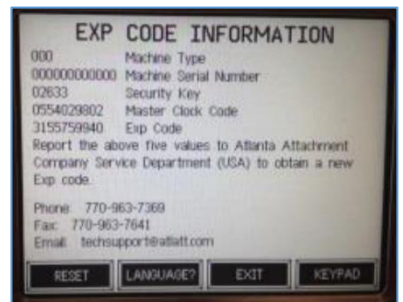

11. The AAC Service department staff will provide you with the new EXP CODE value.

12. To enter it, press the KEYPAD button at the bottom right of the screen.

13. Enter in the new EXP CODE value using then left and right buttons to position the cursor where desired. Use the Increment and Decrement buttons above and below to adjust the value under the cursor. When the 15-digit number is correct, Press Enter.

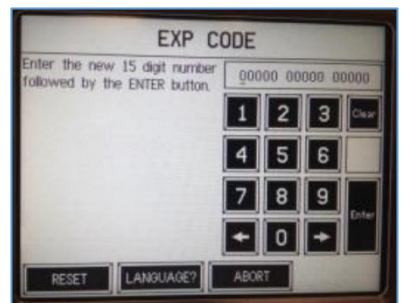

14. Press RESET to reboot the machine.

### 3.6.10. Technical Screens

#### 1. Introduction

The touch screen is divided into two major categories: Functions accessible to the operator and advanced functions accessible to the technician. The advanced functions consist of five security levels: Supervisor, Mechanic, Chief Mechanic, Technician, and Engineer. To access the technical functions, a security key must be entered

The [MACHINE ADJUSTMENTS] screen and [ADVANCED ADJUSTMENTS] screen require a verification key code. Using the correct key code will allow the [ADVANCED OPTIONS] screen to appear. The key code may be changed to any 5-digit number at the [SECURITY] screen.

In the normal operator's mode, a warning message is displayed when the machine encounters an error and presents various options to the operator to continue the resolve or continue machine's cycles.

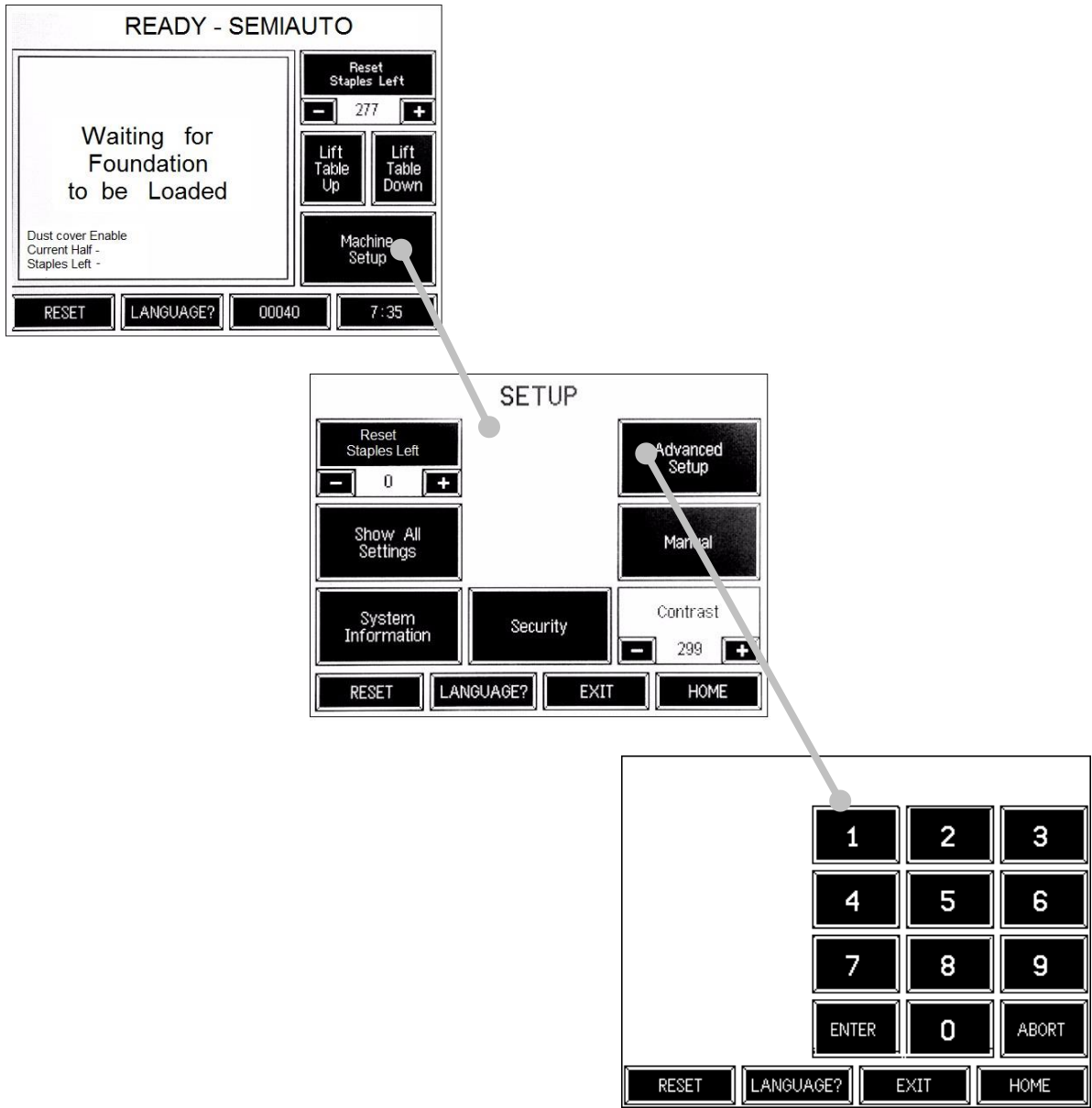

### 2. Show All Settings

Shows the current parameter values being used by the machine. It doesn't show the function, only the value. Before any program or module change, take notes of these values or a picture in case of any program issues.

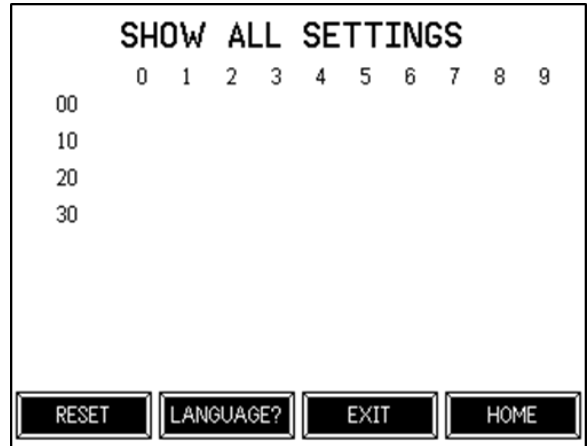

### 3. System Information

Show combined Data and Program module from the memory module.  
Serial number is store on the memory module and software with controller on the program module.

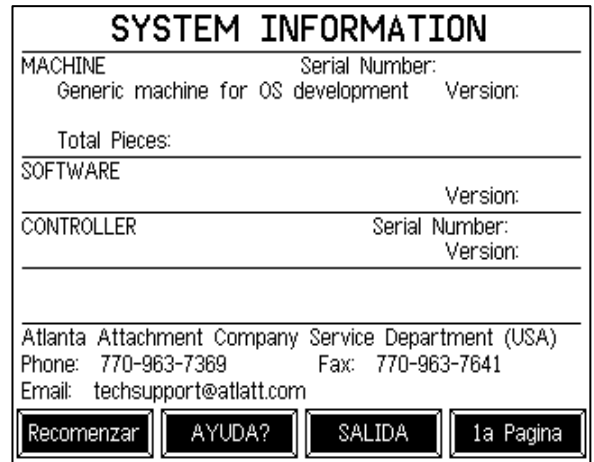

## Service Instructions

### 4. Advanced Set Up

This consists of two major series of screens. [ADVANCED SET UP 1] [ADVANCED SET UP 2] and [ADVANCED SET UP 3.] To navigate to the various screens, lightly tap the arrow buttons located at the upper corners of the touch screen.

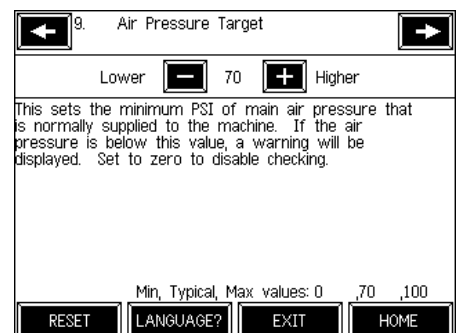
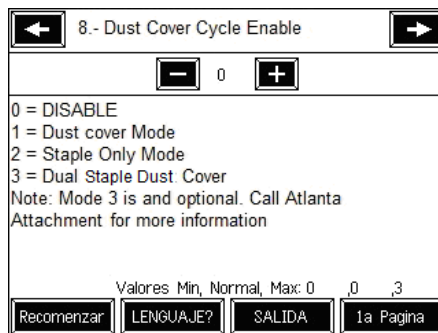
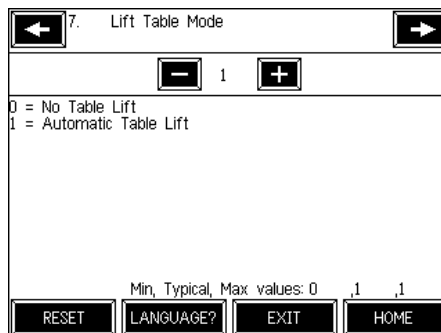
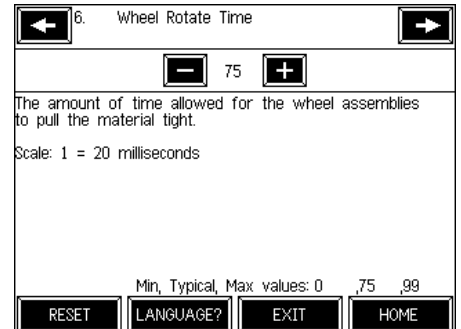
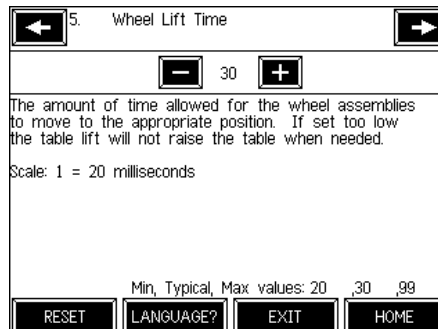
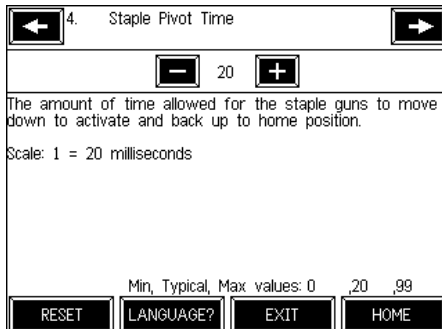
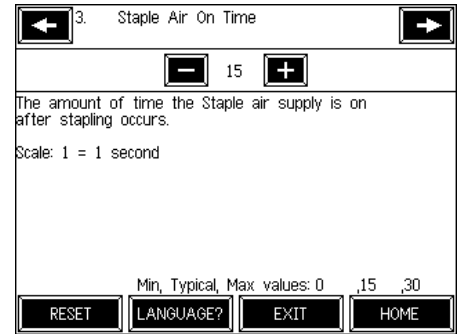
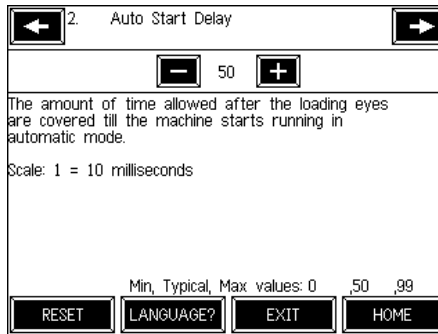
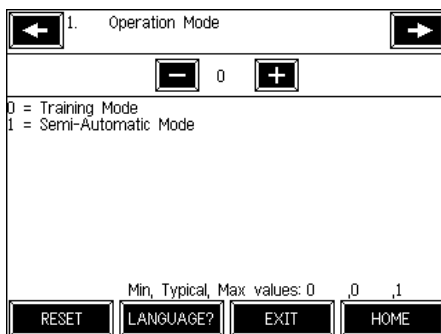
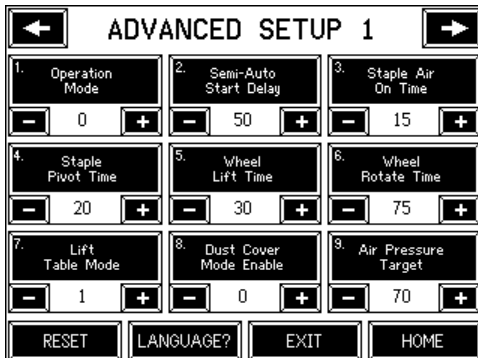

## Service Instructions

← ADVANCED SETUP 2 →			
10. Rotate Lift Automatic Enable - 1 +	11. Rotate Lift Start Delay - 35 +	12. Rotate Lift On Time - 35 +	
13. Staple Air Enable - 1 +	14. Staple Reload Count - 360 +	15. Wheel Pressure Time - 50 +	
16. Trigger Air On Time - 50 +	17. Wheel Down Delay - 50 +	18. Table Lift Down Time for Dust Cover - 50 +	
RESET	LANGUAGE?	EXIT	HOME

← 12. Rotate Lift On Time →	
- 35 +	
The amount of time the Rotate Lift stays in the up position when Rotate Lift Auto is enabled.	
Scale: 1 = 100 milliseconds	
Min, Typical, Max values: 0 ,35 ,50	
RESET	LANGUAGE? EXIT HOME

← 11. Rotate Lift Start Time →	
- 35 +	
The amount of time allowed after the Start Eyes are uncovered until the Rotate Lift activates when Rotate Lift Auto is enabled.	
Scale: 1 = 10 milliseconds	
Min, Typical, Max values: 0 ,35 ,99	
RESET	LANGUAGE? EXIT HOME

← 13. Staple Air Enable →	
- 1 +	
0 = DISABLED 1 = ENABLED	
If disabled the machine will run normally but the Staple Guns will not activate.	
Min, Typical, Max values: 0 ,1 ,1	
RESET	LANGUAGE? EXIT HOME

← 14. Staple Reload Count →	
- 360 +	
The number of staples in each gun when it fully loaded.	
Min, Typical, Max values: 150 ,360 ,500	
RESET	LANGUAGE? EXIT HOME

← 15. Wheel Pressure Time →	
- 50 +	
The amount of time allowed for the wheel assemblies to re-apply pressure before stapling.	
Scale: 1 = 2 millisecond	
Min, Typical, Max values: 0 ,50 ,99	
RESET	LANGUAGE? EXIT HOME

← 16. Trigger Air On Time →	
- 50 +	
The amount of time allowed for the Trigger mechanism to press the staple gun trigger.	
Scale: 1 = 20 milliseconds	
Min, Typical, Max values: 0 ,50 ,99	
RESET	LANGUAGE? EXIT HOME

← 17. Wheel Down Delay →	
- 50 +	
The amount of time allowed between when the Edge Clamp moves down and the Wheels move down.	
Scale: 1 = 20 milliseconds	
Min, Typical, Max values: 0 ,50 ,99	
RESET	LANGUAGE? EXIT HOME

← 18. Table Down Time for Dust Cover Modes →	
- 50 +	
The amount of time allowed for the table to move down during Dust Cover staple.	
Scale: 1 = 10 milliseconds	
Min, Typical, Max values: 0 ,50 ,99	
RESET	LANGUAGE? EXIT HOME

← ADVANCED SETUP 3 →	
19. High Pressure Wheel select - 0 +	
0 = DISABLED 1 = Current Half = 1 High Pressure 2 = Current Half = 1 or 2 High Pressure	
Controls Tension Wheels dropping with high pressure and remaining at high pressure thought the cycle	
Min, Typical, Max values: 0 0 ,2	
RESET	LANGUAGE? EXIT HOME

← 19. High Pressure Wheel Select →	
- 0 +	
0 = DISABLED 1 = Current Half = 1 High Pressure 2 = Current Half = 1 or 2 High Pressure	
Controls Tension Wheels dropping with high pressure and remaining at high pressure thought the cycle	
Min, Typical, Max values: 0 0 ,2	
RESET	LANGUAGE? EXIT HOME

## 5. Advanced Manual

This area of the program allows access to the Input and Output modules. There are three principal screens. To move between screens, tap the arrow buttons on the upper top corners of the

touch screen

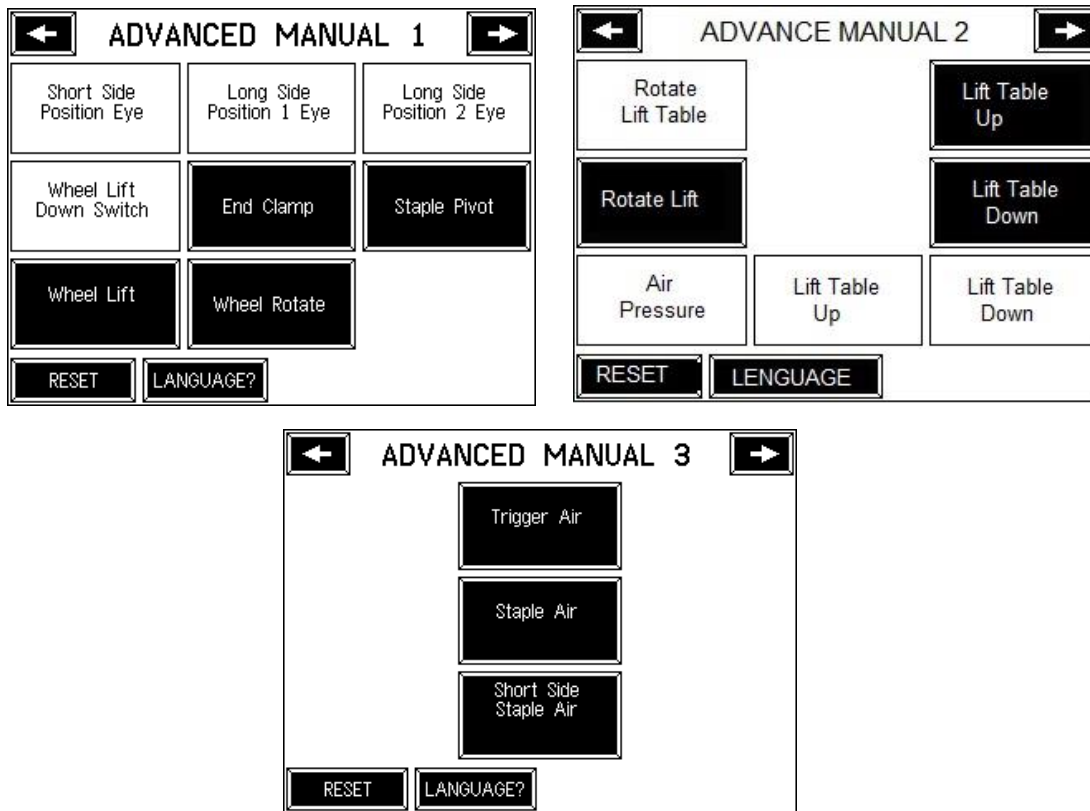

### A. Input

In the Input Sensor screen you can verify the function of the input sensors. A double line will appear on the sensor's window indicating that the sensor is activated.

### B. Output

In the output screen you may activate the machine's output devices (such as valves) by tapping the corresponding output control window.

**ATTENTION:** Be extremely careful while manually activating output devices since this will activate various parts of the machine without any interlocking or safety controls of the main program. This may in some cases cause damage to the machine or to personnel.

**NOTE:** The SHORT SIDE function in the advanced manual 3 is optional. Disconnect the short side of the stapling area. Work only if the correct hardware has been installed.

## 3.7. Maintenance

**NOTE:** Always wear proper safety equipment when operating or performing maintenance on any equipment.

It is important that the machine operator read this manual and is familiar with all the functions and safety concerns of the unit before operating.

### 3.7.6. General Safety Instructions

Maintenance should only be performed by trained, qualified personnel. Before performing any maintenance or repair work, switch off the electrical, pneumatic, etc. power to the machine at the main source and secure it with a padlock so that it cannot be switched on again without authorization. Refer to lockout/tag out procedures

- Always wear proper safety equipment when operating or performing maintenance on any equipment.
- All recommended maintenance is for a single shift schedule; adjust as necessary for a multi-shift operation.
- Equipment should not be used for purposes other than designed or specified.
- The machine shall be switched off, come to a standstill, and be secured so that it cannot be switched on again inadvertently before starting any maintenance work whatsoever.
- Use proper lockout/tag out procedures to secure the machine against inadvertent startup.
- Remove any oil, grease, dirt, and waste from the machine, particularly from the connections and screws, when starting the maintenance and/or repair work.
- Do not use any corrosive-cleaning agents.
- Use lint-free rags.
- Retighten all screw connections that have to be loosened for the maintenance and repair work.
- Any safety mechanisms that have to be dismantled for setting-up, maintenance or repair purposes must be refitted and checked immediately after completing the work

3.7.7. Preventive Maintenance 40 Hrs.



# Preventive Maintenance 40 Hrs

<b>Model:</b>	1331 Series	<b>Required Materials</b> Oilcan Oil Clean cloth
<b>Serial #:</b>		
<b>Operation:</b>	Stapler	
<b>Needle:</b>		





Open covers, With an air gun blow the machine out and remove accumulated dirt in hard to reach areas	
Lubricate all machine slides in the staplers, stretchers and Tension wheels	
Check the state of air filters "A" and "B" and clean or replace as required. Drain water if necessary.	
Check the condition and level of the lubricating oil in bowl "C" and add or replace as required Adjust the oiler for one oil drop per every five (10) cycles. The oil drops may be viewed with sight glass "D" and adjusted with screw "E".	
Check all air cylinders for correct activation speed. Adjust flow control if required.	
Check height and alignment of the gun and tension wheels assemblies	
Check all mechanical assembly. Tighten loosen components if found.	
<b>- Perform 8 Hrs Maintenance</b>	

**3.7.8. Preventive Maintenance 960 Hrs.**



# Preventive Maintenance 960 Hrs

<b>Model:</b>	1331 Series	<b>Required Materials</b>	
<b>Serial #:</b>		Oilcan	All Purpose Grease Can or Cartridge
<b>Operation:</b>	Stapler	Oil	
		Clean cloth	
<b>Serial #:</b>		Compressed air	

Open or remove doors and/or covers and inspect debris or wear and clean or replace as necessary.	
Inspect pillow blocks and apply one shot of recommended oil	
Drain and refill the lubricant oil in bowl "C" Adjust the oiler for one oil drop per every five (5) cycles.	
Replace air filter "A" and "B". Drain the air accumulator	
Lubricate the column lifter and adjust the stabilizers if required	
<b>.- Perform 40 Hrs Maintenance</b>	

### 3.8. Troubleshooting

#### 3.8.6. Screen Messages

Error	Cause:	Corrective action:
<p style="text-align: center;"><b>LIFT TABLE ERROR</b></p> <p>The Lift Table did not reach the Pull Wheels in a reasonable amount of time.</p> <p style="text-align: center;"> <input type="button" value="RESET"/> <input type="button" value="LANGUAGE?"/> </p>	<p>The lift table did not reach the wheel in a reasonable time</p>	<p>Check the wheel cylinder sensor if it is working properly</p>
<p style="text-align: center;"><b>NO FOUNDATION LOADED</b></p> <p>In training mode, when the start button is pressed, all three side eyes must be covered before automatic operation can begin.</p> <p style="text-align: center;"> <input type="button" value="RESET"/> <input type="button" value="LANGUAGE?"/> </p>	<p>No foundation detected</p>	<p>Review that all proximity sensors are covered. Readjust eyes if required</p>
Error	Cause:	Corrective action:
<p style="text-align: center;"><b>Low Air Pressure</b></p> <p>The Air Pressure module has detected that the current pressure level is below the Main Air Low setting. Check air supply.</p> <p style="text-align: center;"> <input type="button" value="RESET"/> <input type="button" value="LANGUAGE?"/> </p>	<p>Air shutoff valve is closed Airline is disconnected from machine Air supply pressure is below 80 PSI Air regulator is adjusted below 80 PSI Air pressure module is disconnected Air pressure switch failed Module 5 has failed</p>	<p>1. Open air valve 2. Connect air line 4. Verify air compressor is running 5. Readjust air pressure regulator to 80 PSI 6. Review air pressure switch connection 7. Replace air module 8.- Verify that there are no restrictions on the airline that are producing air drops</p>
Error	Cause:	Corrective action:

## Service Instructions

<p style="text-align: center;"><b>OUT OF STAPLES</b></p> <p>The Staple guns are out of staples. Reload the guns and press Continue.</p> <p style="text-align: center;"> <input type="button" value="LANGUAGE?"/> <input type="button" value="CONTINUE"/> </p>	<p>Machine ran out of staples</p>	<p>Reload the staples and press continue</p>
<p style="text-align: center;"><b>Dual Staple</b></p> <p>Press any Pedal or the Staple button below to staple the dustcover the second time.</p> <p>Press the Skip button below to continue without stapling.</p> <p style="text-align: center;"> <input type="button" value="Skip"/> <input type="button" value="Staple"/> </p> <p style="text-align: center;"> <input type="button" value="RESET"/> <input type="button" value="LANGUAGE?"/> </p>	<p>Cycle is not in automatic</p>	<p>Reset and change to automatic mode or press the Skip to continue the cycle</p>
<p style="text-align: center;"><b>RESETTING MACHINE</b></p>	<p>Reset bottom was pressed</p>	<p>Wait until machine finish the reset cycle.</p>
<p>Machine does not Turn On</p>	<p>Emergency Stop Activated</p>	<p>Verify that the Emergency Stop bottom is not on the lock down position.</p>
<p>Stapler placed in the wrong location</p>	<p>Stapler Guns need relocation</p>	<p>Proceed to the guide adjustment explained on the mechanical adjustment.</p>
<p>Automatic Cycle do not start</p>	<p>Load Sensors are not activated</p>	<p>Verify that sensors are working and adjusted properly</p>

Service Instructions

---

Problem	Cause:	Corrective action:
Machine do not turn ON	No Power	Check the green button on the lock out switch inside the right door of the machine. If it is not pressed in and lit, press the green button. If it doesn't light up when pressed, check the voltage at the top of the contactor. If there is no voltage, check the breaker at the electrical box. Use the wiring diagram for your machine loaded in the parts manual to check the voltages.
Stapler does not function	Manual cycle activated	Modify the cycle on the Serial Bus screen

## Assembly Drawings & Parts Lists

The materials contained herein are confidential and proprietary information of Atlanta Attachment Company. In addition to any confidentiality and non-disclosure obligations that currently exist between you and Atlanta Attachment Company, your use of these materials serves as an acknowledgment of the confidential and proprietary nature of these materials and your duty not to make any unauthorized use or disclosure of these materials.



### **One-Stop Shopping**

For Expendable Replacement Parts for AAC & Other Bedding Equipment Suppliers

Toll Free: **1-866-885-5100**

[www.atlantapartsdepot.com](http://www.atlantapartsdepot.com) • [sales@atlantapartsdepot.com](mailto:sales@atlantapartsdepot.com)

# 11331B S/A Foundation Stretcher

AAC Drawing Number 9005254 Rev 0

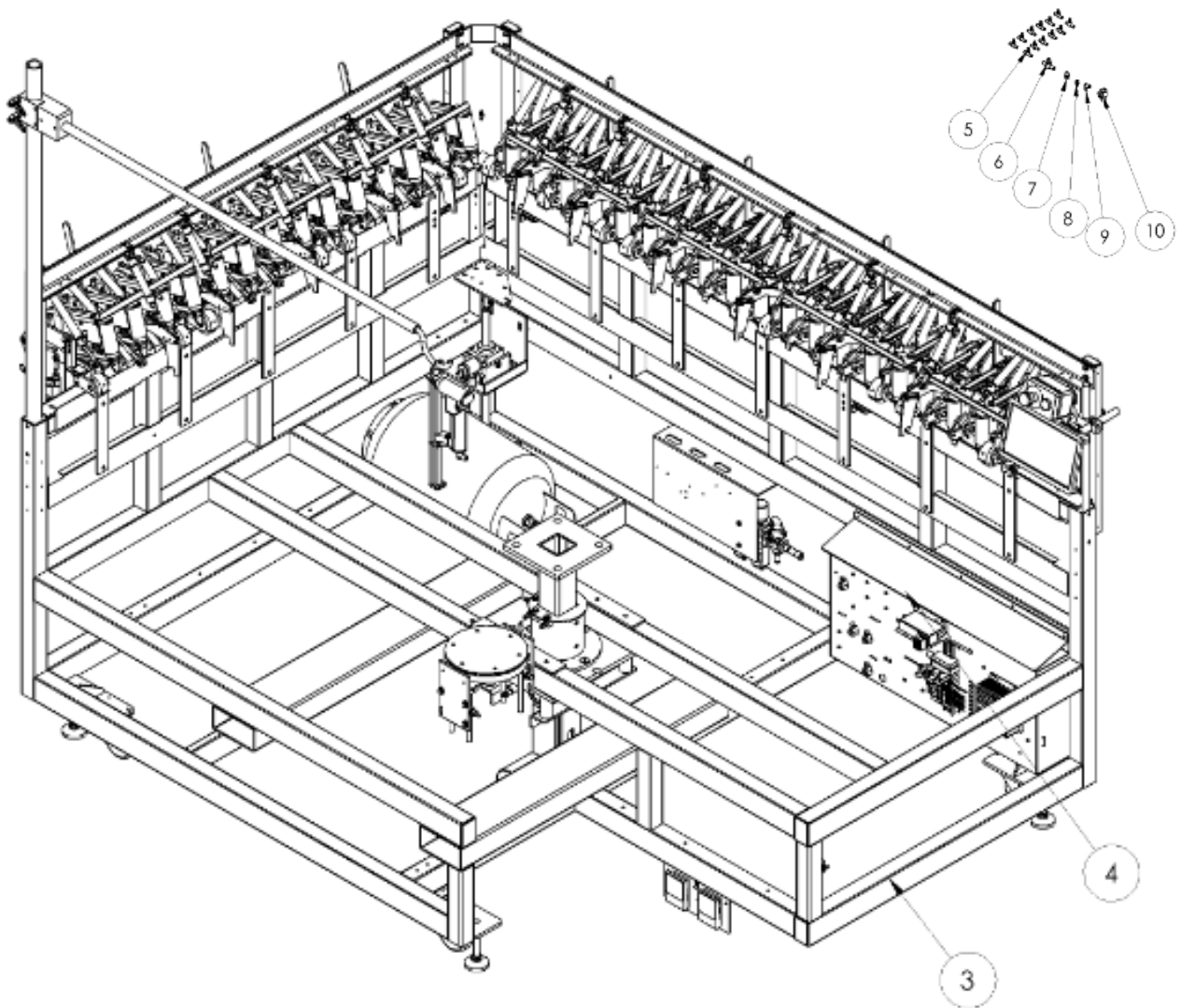

ITEM	QTY.	PART NUMBER	DESCRIPTION
1	1	1331-PD2	DIAGRAM, PNEUMATIC
2	1	1331-WD	DIAGRAM, WIRING
3	1	1331100	GENERIC ASSY,1331B/BC
4	1	1331140	TABLE TOP ASSY.
5	12	AA2000F-03	FLOW CONTROL,INLINE,5/32
6	1	AA3001F-03	FLOW CONT,INLINE,1/4 LINE
7	1	AAFP28	MUFFLER,1/4 NPT
8	1	AAQMC-4-8	QUICK MALE CONNECT,1/4NPT
9	1	AAQME-4-8	QUICK MALE ELBOW, 1/4T
10	1	AAVSQE1	VALVE,QUICK EXHAUST

# 11331BC S/A Foundation Stretcher

AAC Drawing Number 9005255 Rev 0

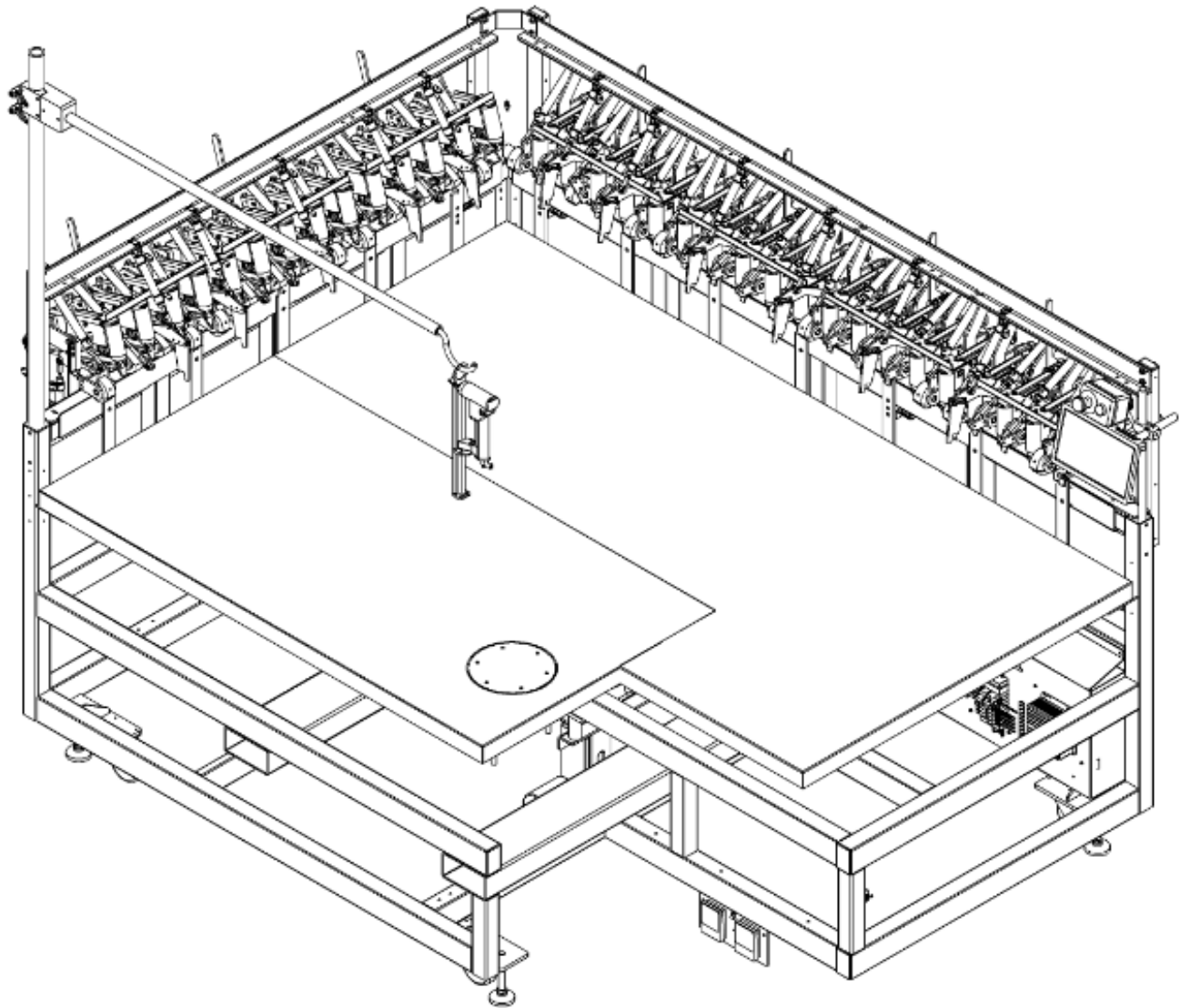

ITEM	QTY.	PART NUMBER	DESCRIPTION
1	1	1331100	GENERIC ASSY,1331B/BC
2	1	1331393	TABLE TOP ASSY
3	12	AA2000F-03	FLOW CONTROL,INLINE,5/32
4	1	AA3001F-03	FLOW CONT,INLINE,1/4 LINE
5	1	AAFP28	MUFFLER,1/4 NPT
6	1	AAQMC-4-8	QUICK MALE CONNECT,1/4NPT
7	1	AAQME-4-8	QUICK MALE ELBOW, 1/4T
8	1	AAVSQE1	VALVE,QUICK EXHAUST

# 11331BD S/A Divan Foundation Stretcher

AAC Drawing Number 9003551 Rev 0

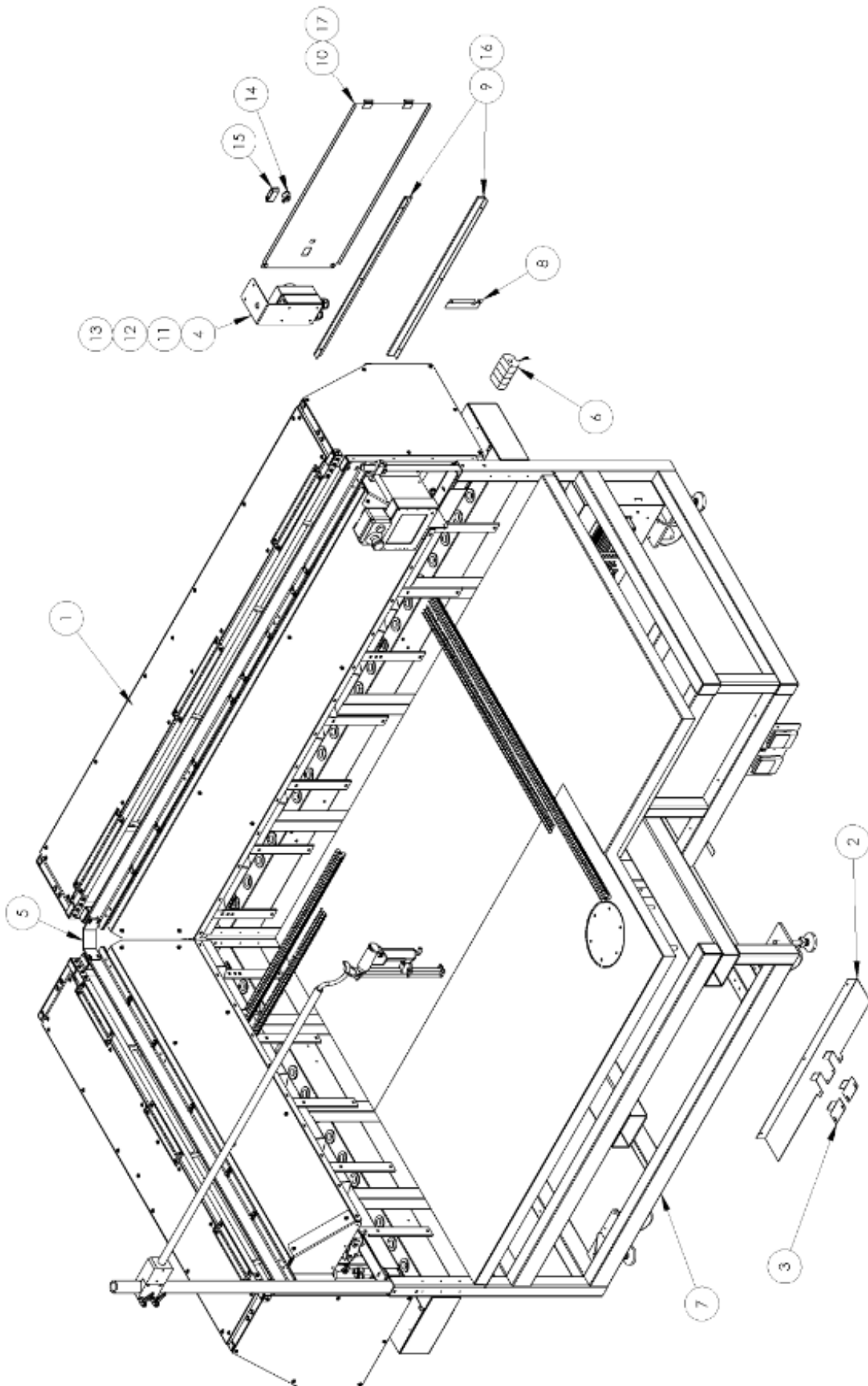

11331BD parts list

ITEM	QTY.	PART NUMBER	DESCRIPTION
1	1	1331293	SEALY UK SAFETY GUARDS
2	1	1331553	COVER,CONTROL BOX,TOP
3	2	1331554	BRKT,CLAMP
4	1	1331555	BRACKET, Q-DISCONNECT
5	1	1331556	BRKT,CORNER
6	4	1331561	WHEEL, TENSION
7	1	1331567	MAIN ASSY,11331BD
8	1	1331568	BRKT,CE CERTIFICATION
9	2	1331569	BRKT,DOOR,CE
10	1	1331570	DOOR
11	1	EE194EY25	SWITCH,DISCONNECT,25 AMP
12	2	FF3460	STRAIN RELIEF,LIQ TIGHT, 3/4NPT
13	2	FF8465	NUT,LOCK, 3/4NPT,NYLON,BLK
14	1	MM1770A12	DOOR LATCH, CAM, KEYED
15	1	MM40450010	FASTENER,SLIDE LOCK
16	2	MM93745K45	FOAM,SOFT,BUNA-N,1/4X1
17	2	MMSLD-ECH	1/2" DIA RUBBER BUMPER



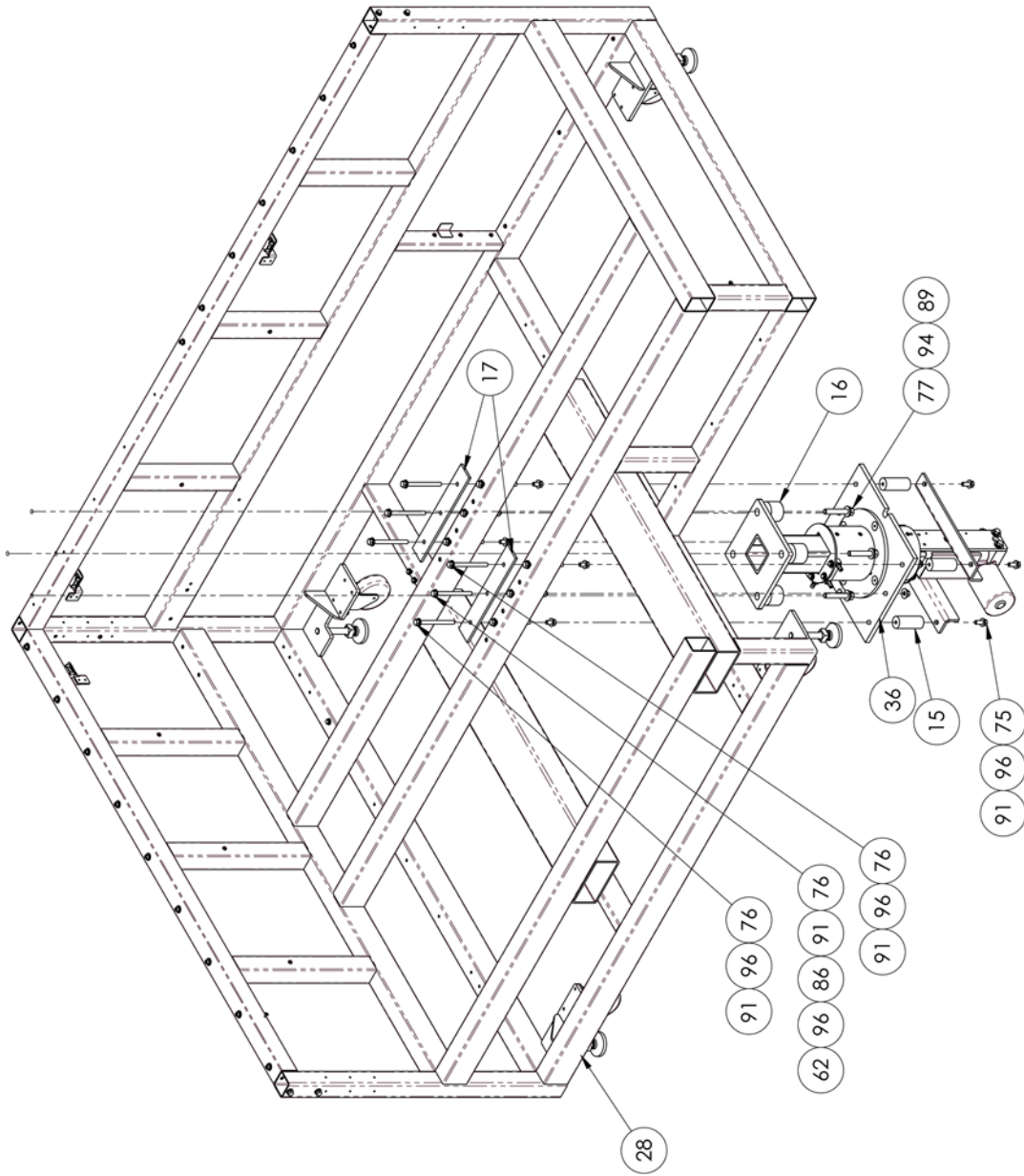

Service Instructions

1331100 parts list

NO	QTY	PART #	DESCRIPTION	NO	QTY	PART #	DESCRIPTION
1	1	40-112A	MOUNT, TOUCH SCREEN	52	1	CCCL12F	CLAMP COLLAR- 3/4
2	4	0411-1063	THREADED ROD	53	3	FF06H205	EYE, BKGND SUPPRESS,ADJ
3	1	1278-6010	START/STOP BUTTON ASSY	54	2	MM132-2X2A	END CAP, SQUARE, BLACK
4	1	1331-WD	DIAGRAM, WIRING	55	3	MM132-2X3	END CAP, RECT,BLACK,2X3
5	*1	1536-069A	FOOTSWITCH ASSY	56	4	MM431-4	CASTER,4",W/LOCKS
6	1	4080-004	CONTROLLER,SBUS,6.5",VGA	57	1	MM40450010	FASTENER,SLIDE LOCK
7	1	26254C	AIR RESERVOIR	58	4	MML-2	LEVELING PAD, 5/8-11
8	1	28201	SCREW, HEX CAP	59	2	MMSLD-ECH	1/2" DIA RUBBER BUMPER
9	1	1331042	PIVOT LIFT ASSY.	60	4	NNE1/4-20	NUT,ELASTIC LOCK,1/4-20
10	1	1331062	BRKT,SIDE SUPPORT,SHORT	61	2	NNH1/4-20	NUT,HEX,1/4-20
11	1	1331064	BRKT,SIDE SUPPORT,LONG	62	4	NNH3/8-16	NUT,HEX,3/8-16
12	13	1331065	BUMPER, POSITION	63	4	NNK1/4-20	NUT,KEP,1/4-20
13	1	1331077	LONG SIDE STAPLE GUN ASSY	64	8	NNSH5/8-11	NUT, SQUARE, 5/8-11
14	1	1331078	STAPLE GUN ASSY,SHORT SD	65	38	SSFC98024	#10-32 X .375 FLAT CAP
15	4	1331114	SPACER,COLUMN HUB SUPPORT	66	2	SSHC01032	1/4-20 X 1/2 HHCS
16	1	1331117	SPACER,TABLE TOP,1.5	67	16	SSHC01048	1/4-20 X 3/4 HEX CAP
17	2	1331118	WASHER PLATE,COLUMN LIFT	68	2	SSHC01064	1/4-20 X 1 HHCS
18	3	1331138	BUMPER, POSITION, W/ EYE	69	4	SSHC01096	1/4-20 X 1-1/2 HHCS
19	1	1331158	DOOR	70	2	SSHC01192	HEX HEAD BOLTS, 1/4-20 X
20	1	1331159	PLATE, AIR TANK LOCKING	71	4	SSHC01256	SCREW,HEX CAP
21	1	1331172	ROD,FLATTED,CRS,3/4ODX20L	72	1	SSHC05032	1/4-28 X 1/2 HEX CAP
22	1	1331178	PNEUMATIC PANEL	73	2	SSHC10040	5/16-18 X 5/8 HHCS
23	1	1331185	OVERHEAD STAPLE GUN HLDR	74	4	SSHC25048	3/8-16X3/4,HEX CAP
24	AR	1331227	BRKT,STOP, LONG	75	4	SSHC25064	3/8-16 X 1,HEX CAP
25	AR	1331228	BRKT,STOP,SHORT	76	12	SSHC25288	3/8-16X4-1/2,HEX CAP
26	1	1331247	CORNER SUPPORT ASSY.,RH	77	4	SSHC45192	1/2-13X3 HEX CAP
27	1	1331275	GUARD,CONTROL PANEL,UPPER	78	20	SSHC98024	10-32 X 3/8 HEX CAP
28	1	1331394	BASE FRAME ASSY.	79	6	SSHC98048	SCREW, HEX CAP #10-32X.75
29	1	1331504	PEDAL ASSY,TABLE LIFT	80	37	SSSC01032	1/4-20X1/2 SOC CAP
30	1	1331556	BRKT,CORNER	81	4	SSSC01128	1/4-20 X 2 SOC CAP
31	3	1331805	BRKT,EYE,FF06H205	82	2	SSSC90064	#8-32 X 1 SOC CAP SC
32	1	1331900	CONTROL BOX	83	6	SSSCM3X14	M3-0.5X14 ,SOCKET CAP
33	1	1331903	LONG SIDE TRACK ASSY.	84	25	SSZS93032	SCREW, SHT.METAL 10 ZIP
34	1	1331908	SHORT SIDE TRACK ASSY.	85	17	WWF1/4	WASHER, FLAT, 1/4", COM
35	1	1331914	MANUAL STAPLER ASSY.	86	2	WWF3/8	WASHER,FLAT,3/8 OR 10MM
36	1	13452000C	TABLE, LIFT ASSY, SQUARE	87	2	WWF8	WASHER, FLAT, #8
37	1	AAQMC-3-4	QUICK MALE CONNECTOR	88	6	WWFM3	FLAT WASHER, M3
38	4	AAQPP-07	QUICK PLUG 1/4	89	4	WWFS1/2	WASHER,FLAT,1/2, SAE
39	3	AAQPP-11	PLUG, QUICK 3/8 TUBE	90	9	WWFS1/4	WASHER,FLAT,SAE,1/4
40	3	AAQPR-3-4	QUICK REDUCER 3/8-1/4	91	22	WWFS3/8	WASHER,FLAT,SAE,3/8
41	1	AAQPR-5-4	QUICK PLUG-IN REDUCER	92	2	WWFS5/16	WASHER,FLAT,SAE,5/16
42	17	AAQPR-8-5	QUICK PLUG RED,1/8X5/32	93	12	WWFS10	WASHER, FLAT, #10, SAE
43	1	AAQSU-4-4	UNION,QUICK STATION,1/4X	94	4	WWL1/2	1/2 LOCK WASHER
44	9	AAQSU-5-5	UNION,QUICK STATION,5/32	95	64	WWL1/4	WASHER,LOCK, 1/4
45	7	AAQUY-3-3	QUICK UNION Y 3/8 X 3/8	96	20	WWL3/8	WASHER,LOCK, 3/8
46	12	AAQUY-4-4	Y UNION, 1/4X1/4	97	2	WWL5/16	WASHER,LOCK, 5/16
47	4	AAQUY-5-5	QUICK UNION Y, 5/32	98	2	WWL8	WASHER,LOCK,#8
48	1	AAVAKH11	VALVE,CHECK,3/8 TUBE	99	9	WWL10	WASHER,LOCK,#10
49	*1	AAVBG35A	HOSE,COIL,1/4 OD X 10 FT	100	6	WWLM3	WASHER, LOCK, M3
50	1	AAVMJV-3	VALVE,TOGGLE	101	1	AAQPP-03	PLUG,QUICK 5/32 TUBE
51	1	AAVS125	SHUTTLE VALVE,1/8"PORT				

# 1331567 Main Assembly (BD model)

AAC Drawing Number 1331567 Rev 1

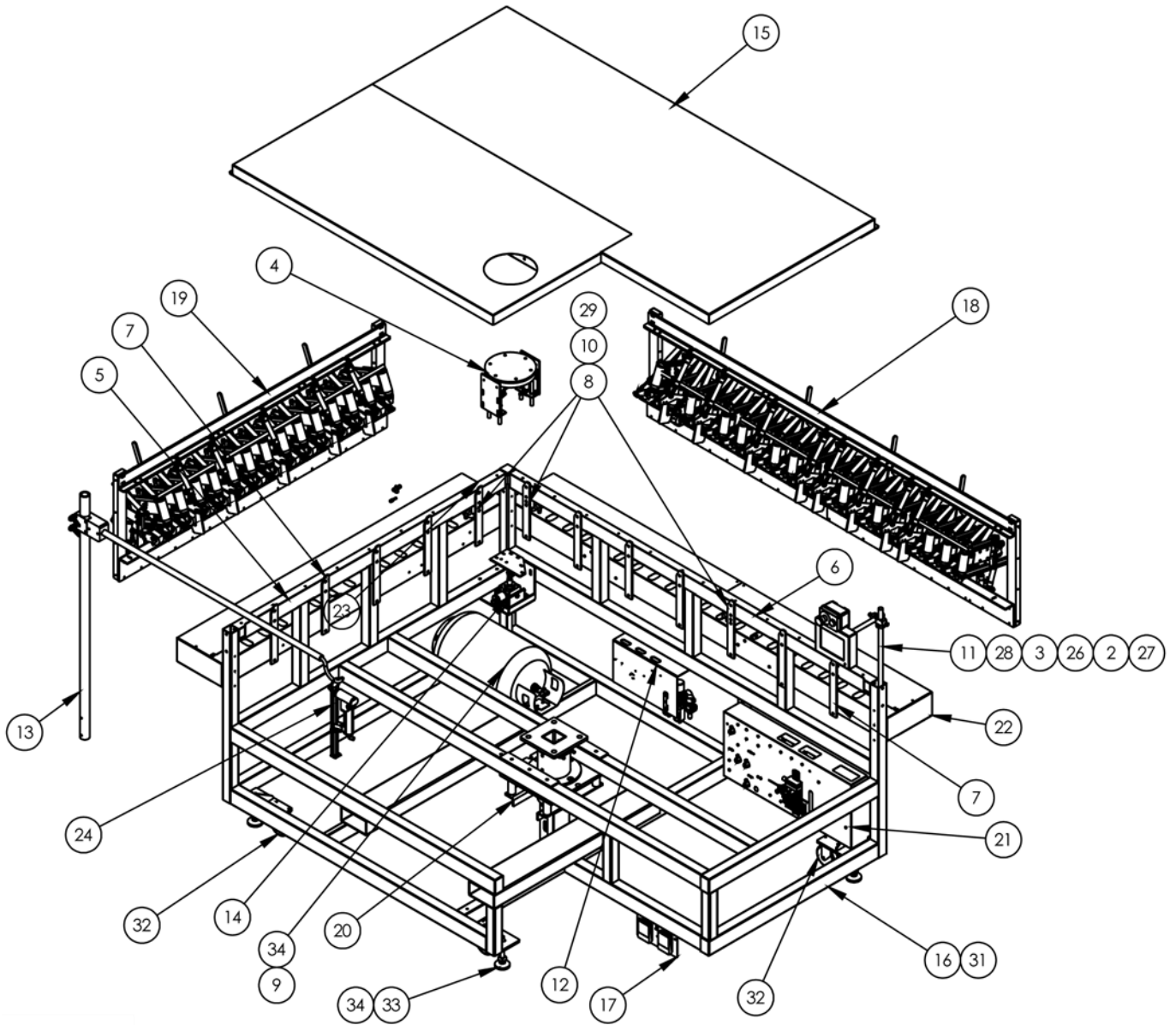

## 1331567 parts list

NO.	QTY	PART #	DESCRIPTION
1	4	0411-1063	ROD, THREADED, 5/8-11 X 5
2	1	1278-6010	START/STOP BUTTON ASSY
3	1	28201	BLOCK,CROSS,(LARGE)
4	1	1331042	PIVOT LIFT ASSY.
5	1	1331062	BRKT,SIDE SUPPORT,SHORT
6	1	1331064	BRKT,SIDE SUPPORT,LONG
7	9	1331065	BUMPER, POSITION
8	3	1331138	BUMPER, POSITION, W/ EYE
9	1	1331159	PLATE, AIR TANK LOCKING
10	3	1331171A	BRKT, EYE, 1331B
11	1	1331172	ROD,FLATTED,CRS,3/4ODX20L
12	1	1331178	PNEUMATIC PANEL
13	1	1331185	OVERHEAD STAPLE GUN HLDR
14	1	1331247	CORNER SUPPORT ASSY.,RH
15	1	1331393	TABLE TOP ASSY
16	1	1331394	BASE FRAME ASSY.
17	1	1331504	PEDAL ASSY, TABLE LIFT
18	1	1331559	LONG SIDE STAPLE GUN ASSY
19	1	1331564	STAPLE GUN ASSY,SHORT SD
20	1	1331565	TABLE, LIFT ASSY, SQUARE
21	1	1331900	CONTROL BOX
22	1	1331903	LONG SIDE TRACK ASSY.
23	1	1331908	SHORT SIDE TRACK ASSY.
24	1	1331914	MANUAL STAPLER ASSY.
25	1	26254C	AIR RESERVOIR
26	1	40-112A	MOUNT, TOUCH SCREEN
27	1	4080-004	CONTROLLER,SBUS,6.5",VGA
28	1	CCCL12F	COLLAR,CLAMP,3/4 BORE
29	3	FFT18FF25Q	EYE, FIXED FIELD, 1IN
30	1	MM132-2X2A	END CAP, SQUARE, BLACK
31	3	MM132-2X3	END CAP, RECT,BLACK,2X3
32	4	MM431-4	CASTER,4",W/LOCKS
33	4	MML-2	LEVELING PAD, 5/8-11
34	8	NNSH5/8-11	NUT, SQUARE, 5/8-11

# 1278-6010 Start / Stop Button Assembly (all models)

AAC Drawing Number 191058B Rev 3

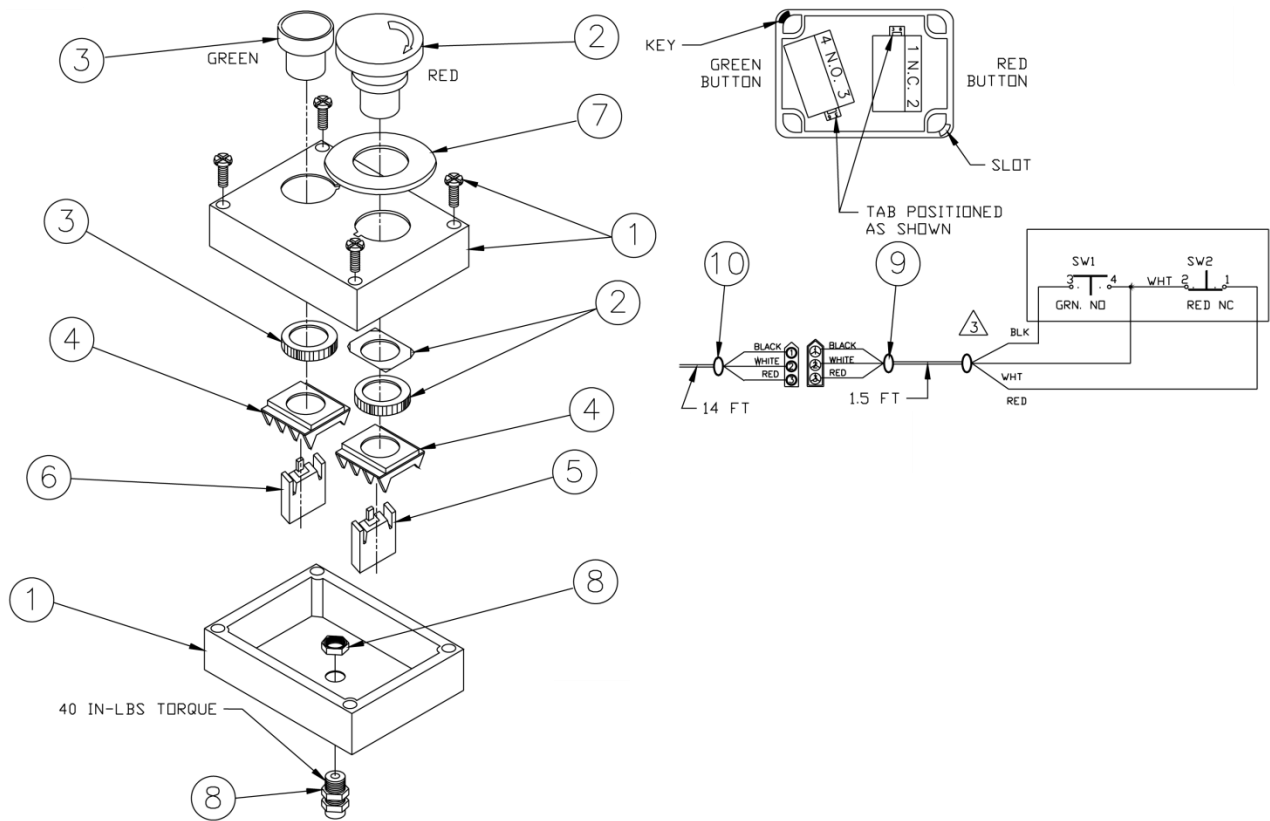

NO.	QTY	PART #	DESCRIPTION
1	1	EEPCB65GM	Enclosure Modif.
2	1	EPM44	E-Stop Button
3	1	EEPF3	Start Button
4	2	EEA3L	Mounting latch
5	1	EE3X01	Contact Block N.C.
6	1	EE3X10	Contact Block N.O.
7	1	EE15Y	Legend Plate
8	1	FF3210	Strain Relief
9	1	4080-4214	Cable
10	1	4080-4215	Cable

## 1331-KIT5 Table Height Adjustment Kit (all models)

AAC Drawing Number 9002273 Rev 0

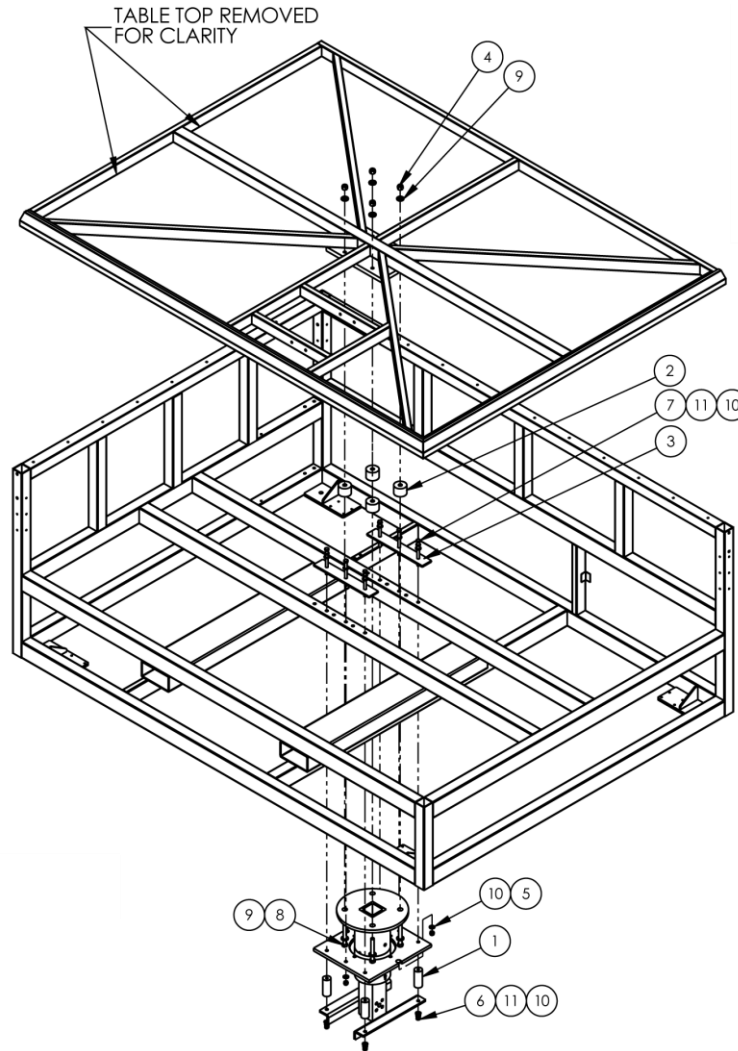

NO.	QTY	PART #	DESCRIPTION
1	4	1331114	SPACER,COLUMN HUB SUPPORT
2	4	1331117	SPACER, TABLE TOP, 1.5
3	2	1331118	WASHER PLATE,COLUMN LIFT
4	4	NNE1/2-13	NUT,NYLOCK,1/2-13
5	2	NNE3/8-16	NUT, ELASTIC 3/8-16
6	4	SSHHC25064	3/8-16X1,HEX CAP
7	6	SSHHC25288	3/8-16X4-1/2,HEX CAP
8	4	SSHHC45160	1/2-13X4 HEX CAP
9	8	WWFS1/2	WASHER,FLAT,SAE,1/2
10	12	WWFS3/8	WASHER,FLAT,SAE,3/8
11	8	WWL3/8	WASHER, LOCK, 3/8

# 1331042 Pivot Lift Assembly (all models)

AAC Drawing Number 1331042 Rev 1

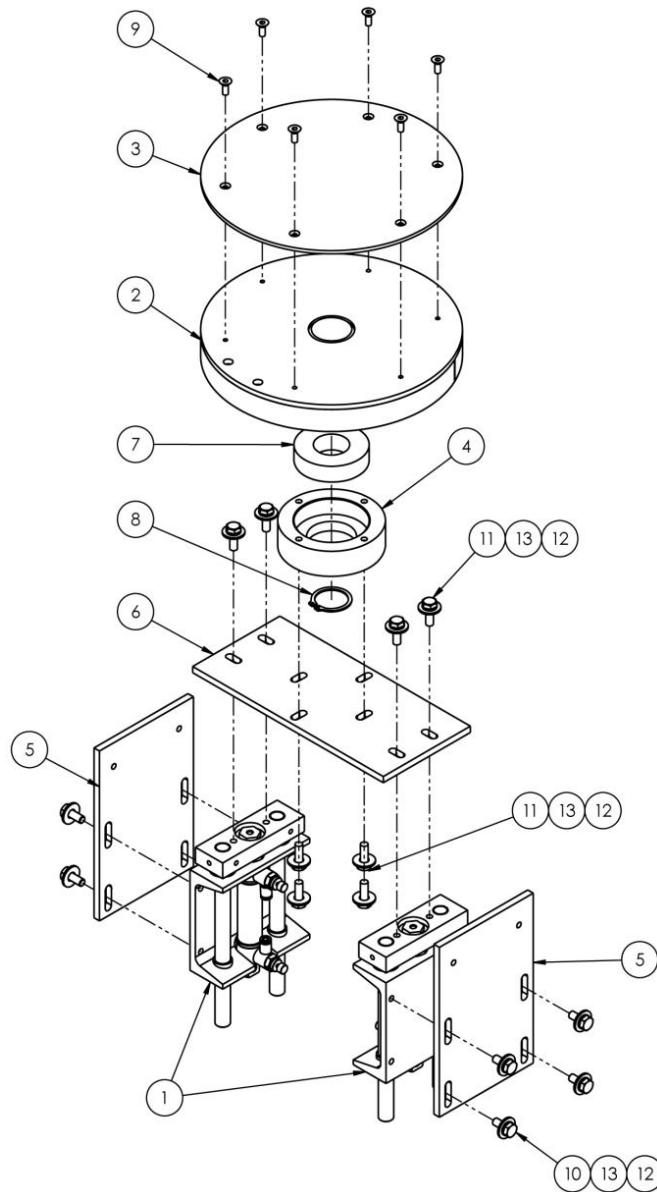

NO.	QTY	PART #	DESCRIPTION
1	2	1331040	ROTATE LIFT CYL ASSY.
2	1	1331041	ROTATION PLATE ASSY
3	1	1331068	PLATE, TABLE TOP, UPPER
4	1	1331071	HUB, BEARING
5	2	1331111	MOUNT, FOUNDATION LIFT
6	1	1331161	MOUNT, ROTATION PLATE
7	1	BB62062RS1	BEARING,BALL,DP GROOVE
8	1	MMSH-118	RING,SNAP,EXT.1.188S,
9	6	SSFC98032	10-32 X 1/2 FLAT ALLEN CAP
10	8	SSHC01040	1/4-20 X 5/8 HHCS
11	8	SSHC01048	1/4-20 X 3/4 SOC CAP SCREW
12	16	WWF1/4	WASHER, FLAT, 1/4", COM
13	16	WWL1/4	WASHER,LOCK,1/4

## 1331185 Overhead Staple Gun Holder(all models)

AAC Drawing Number 1331185 Rev 0

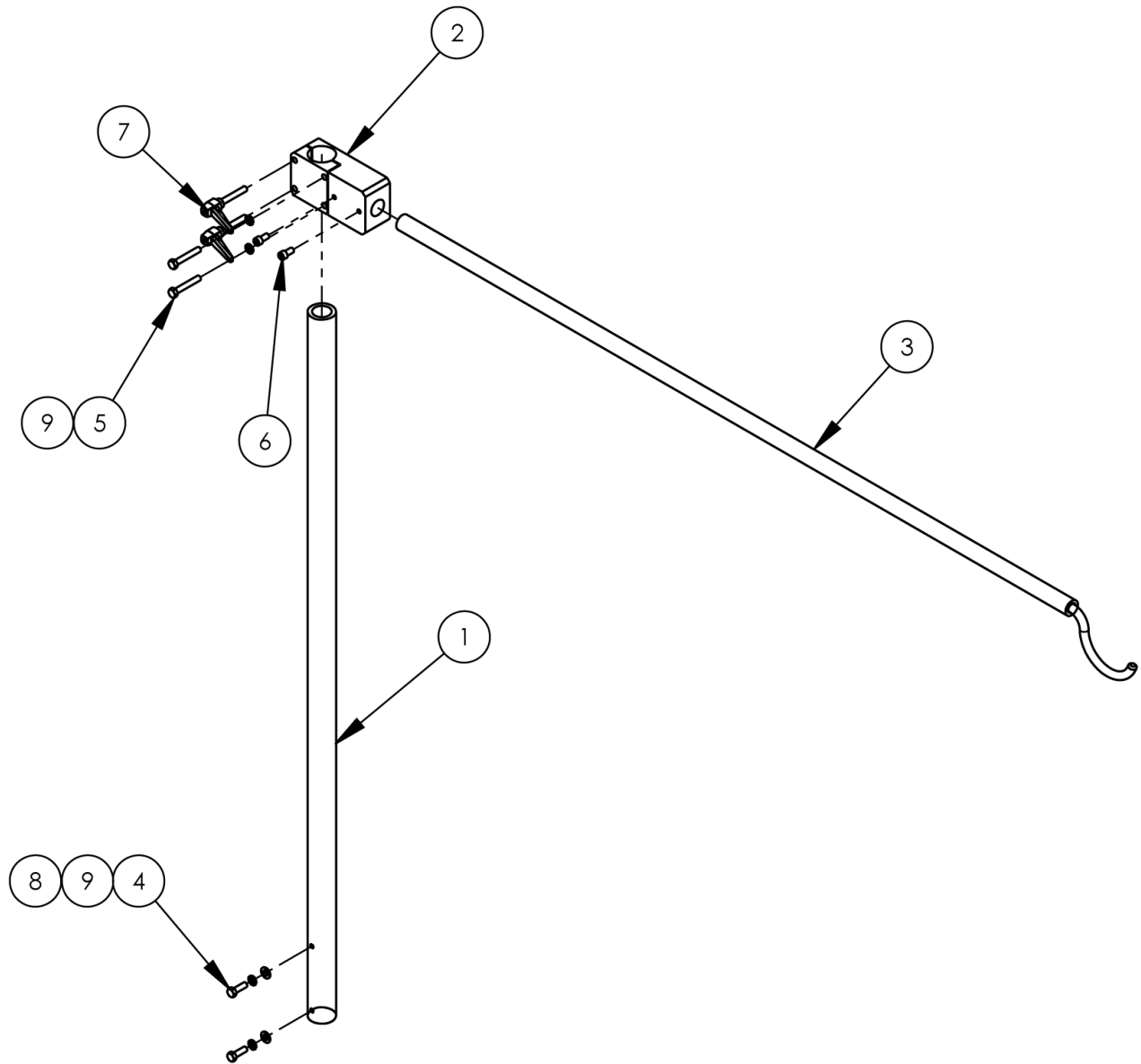

NO.	QTY	PART #	DESCRIPTION
1	1	1331186	TUBE,1-5/8 OD X 54 L
2	1	1331188	BLOCK,CLAMP-T
3	1	1331192	ARM WELDMENT,GUN HLDR
4	2	SSHC10064	5/16-18 X 1" HEX HEAD
5	2	SSHC10128	5/16-18 X 2 HEX HEAD
6	4	WWL10	WASHER,LOCK,#10,S/S
7	2	TTH32429	HANDLE,THRD,5/16-18X2.0
8	2	WWFS5/16	WASHER,FLAT,5/16

# 1331903 Long Sidetrack Assembly (all models)

AAC Drawing Number 1331903 Rev 3

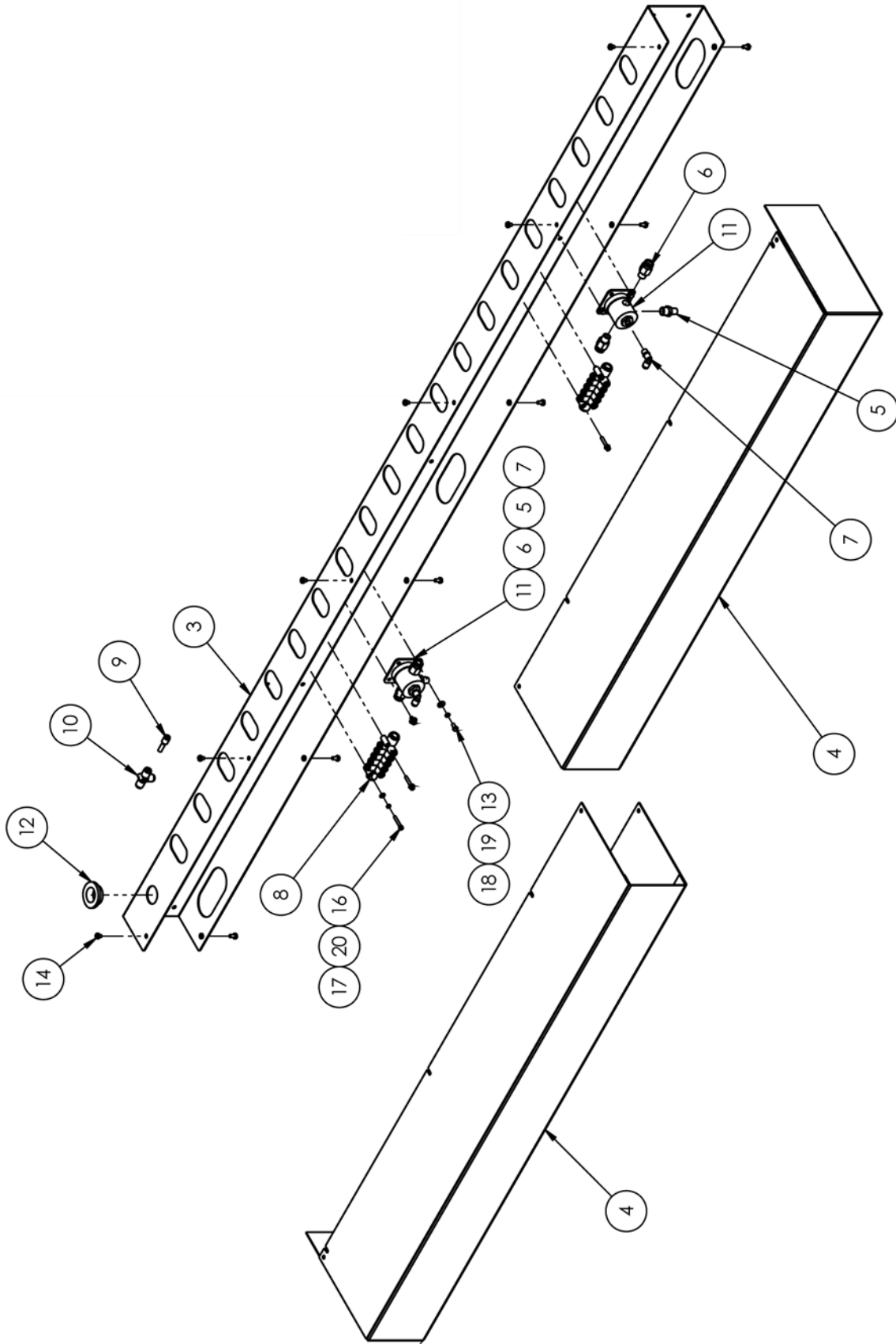

1331903 parts list

NO.	QTY	PART #	DESCRIPTION
*1	AR	1331-PD2	DIAGRAM, PNEUMATIC
*2	AR	1331-PD3	SHORT SIDE FITTING ASSY
3	1	1331902	CHANNEL, AIRLINES, LONG
4	2	1331905	COVER HALF, LONG CHANNEL
5	2	AAFP28	MUFFLER, 1/4 NPT
6	4	AAQMC-3-4	QUICK MALE CONNECTOR
7	2	AAQME-5-8	QUICK MALE ELBOW
8	2	AAQMF-145	10-STATION AIR MANIFLD
9	84	AAQPR-5-4	QUICK PLUG-IN REDUCER
10	114	AAQUT-4-4	QUICK UNION T 1/4X1/4
11	2	AAV250A	PILOT VALVE
12	1	MM9280K33	GROMMET, FLANGE, 1.03 ID
13	4	SSHHC98024	10-32 X 3/8 HEX CAP
14	6	SSPS98016	10-32 X 1/4 PAN HD SLOT
15	6	SSPS98024	10-32X3/8 PAN HD SLOT
16	4	SSSC90064	#8-32 X 1 SOC CAP SC
17	4	WWF8	WASHER, FLAT, #8
18	4	WWFS10	WASHER, FLAT, #10, SAE
19	4	WWL10	WASHER, LOCK, #10, S/S
20	4	WWL8	WASHER, LOCK, #8

# 1331908 Short Side Track Assembly (all models)

AAC Drawing Number 1331908 Rev 2

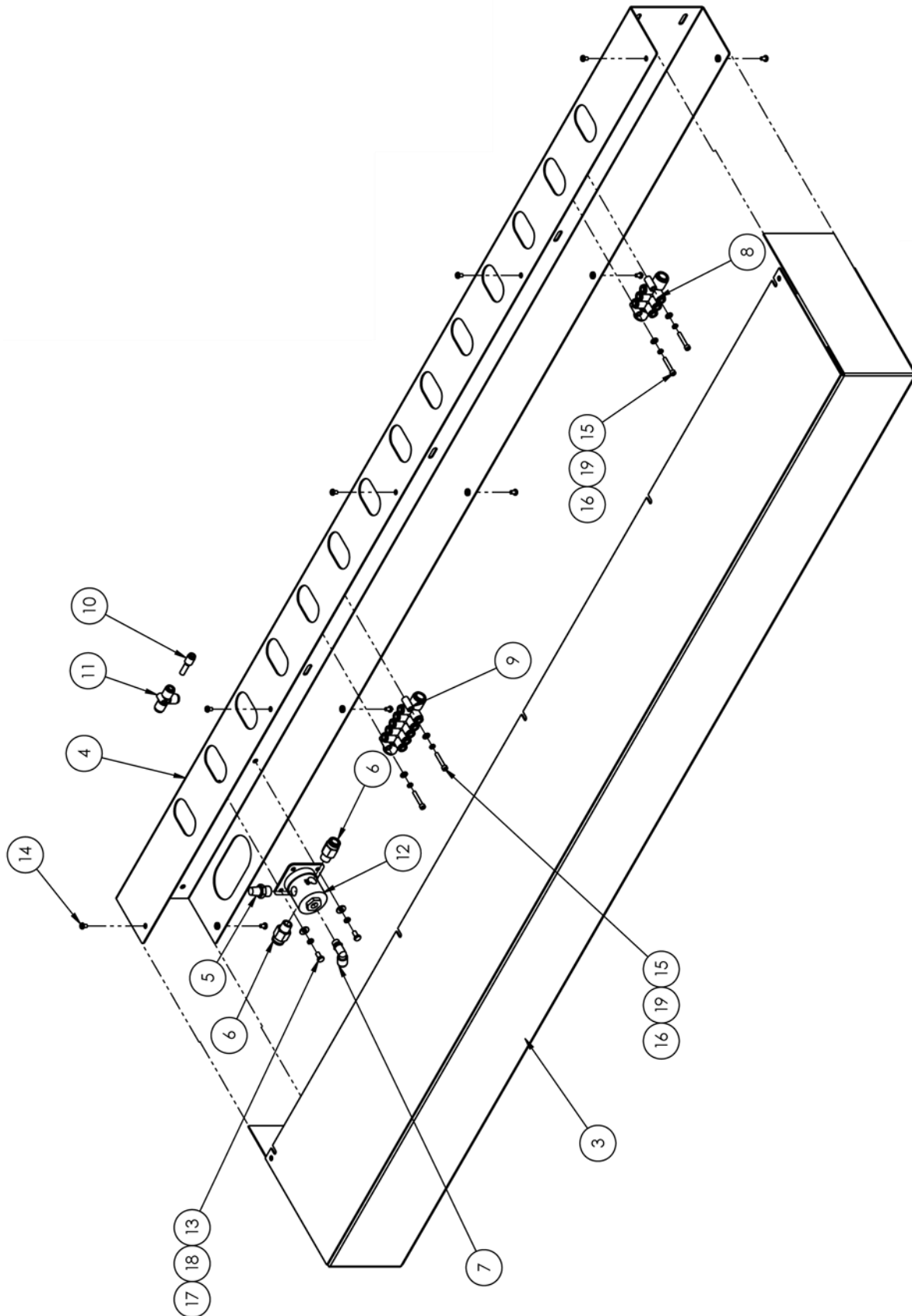

1331908 parts list
--------------------

NO.	QTY	PART #	DESCRIPTION
*1	1	1331-PD2	DIAGRAM, PNEUMATIC
*2	1	1331-PD4	SHORT,SIDE FITTING ASSY
3	1	1331906	COVER, SHORT SIDE CHANNEL
4	1	1331907	CHANNEL, AIRLINES, SHORT
5	1	AAFP28	MUFFLER,1/4 NPT
6	2	AAQMC-3-4	QUICK MALE CONNECTOR
7	1	AAQME-4-8	ELBOW,QUICK MALE,1/4X1/8
8	1	AAQMF-144	6-STATION AIR MANIFOLD
9	1	AAQMF-145	10-STATION AIR MANIFLD
10	64	AAQPR-5-4	QUICK PLUG-IN REDUCER
11	83	AAQUT-4-4	QUICK UNION T 1/4X1/4
12	1	AAV250A	PILOT VALVE
13	2	SSHC98024	10-32 X 3/8 HEX CAP
14	10	SSPS90016	#8-32 X 1/4 LG PAN HD
15	4	SSSC90064	#8-32 X 1 SOC CAP SC
16	4	WWF8	WASHER, FLAT, #8
17	2	WWFS10	WASHER, FLAT, #10, SAE
18	2	WWL10	WASHER,LOCK,#10,S/S
19	4	WWL8	WASHER,LOCK,#8

# 1331077 Long Side Staple Gun Assembly (B & BC)

AAC Drawing Number 1331077 Rev 10

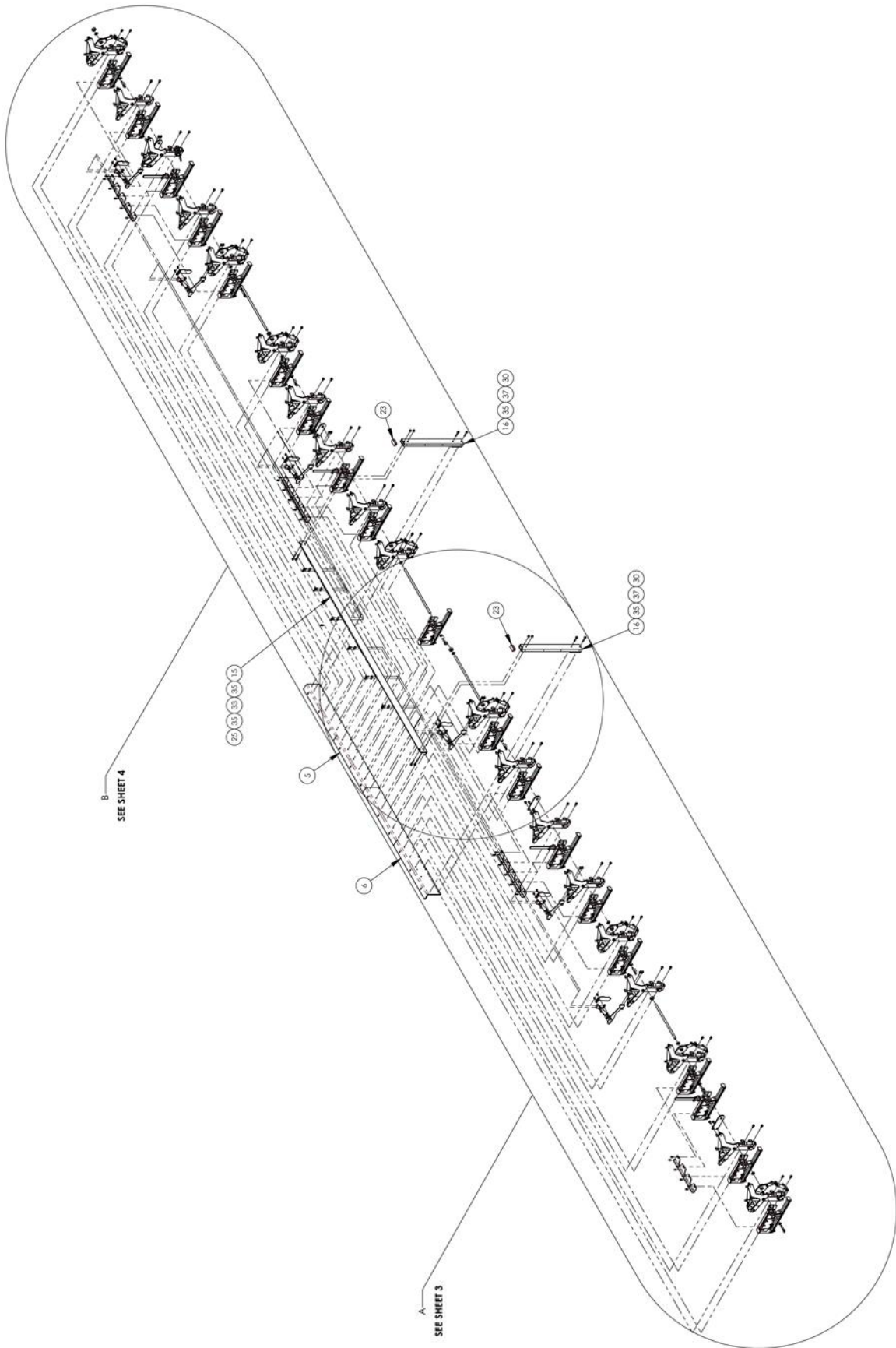

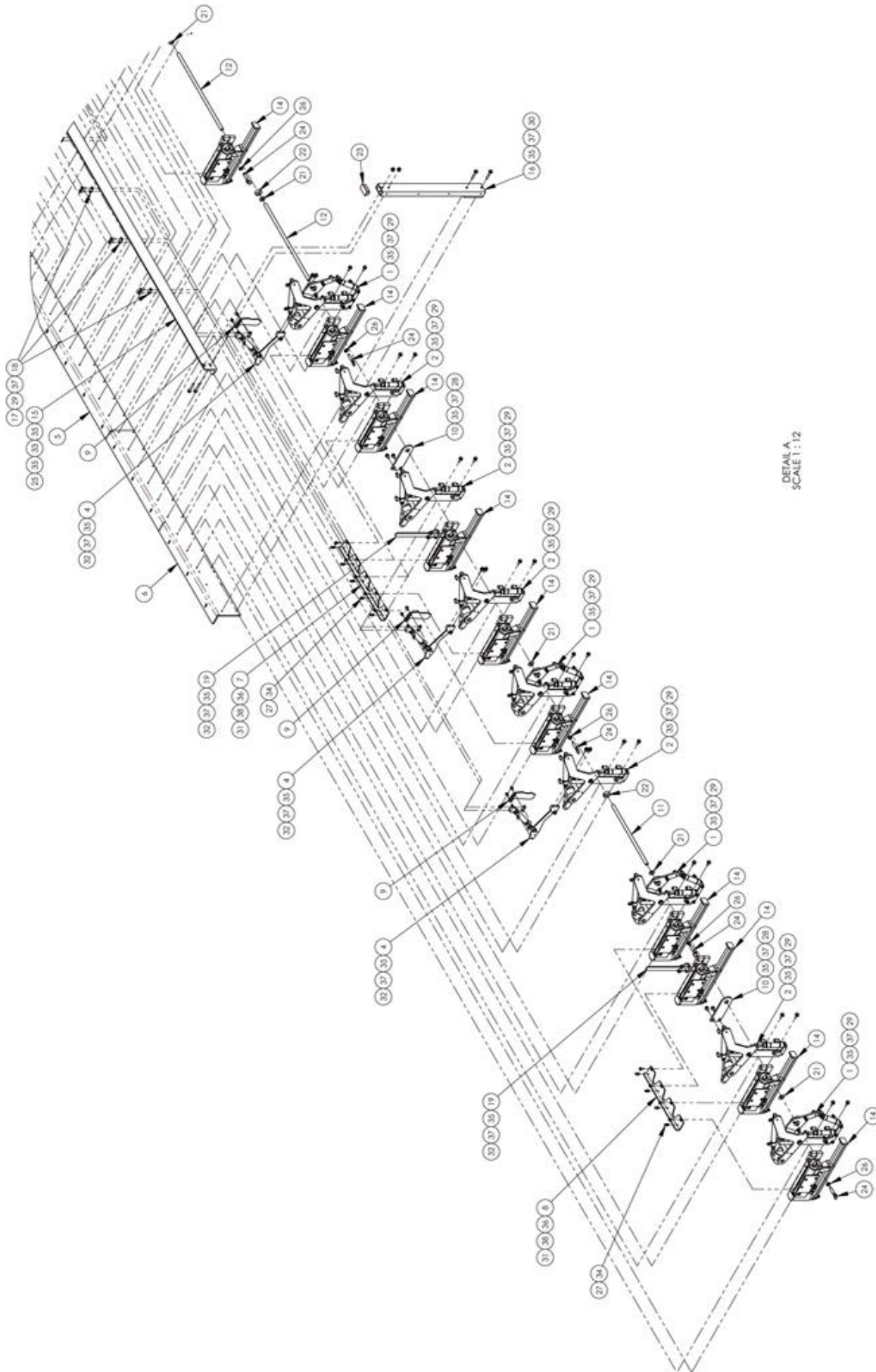

Service Instructions

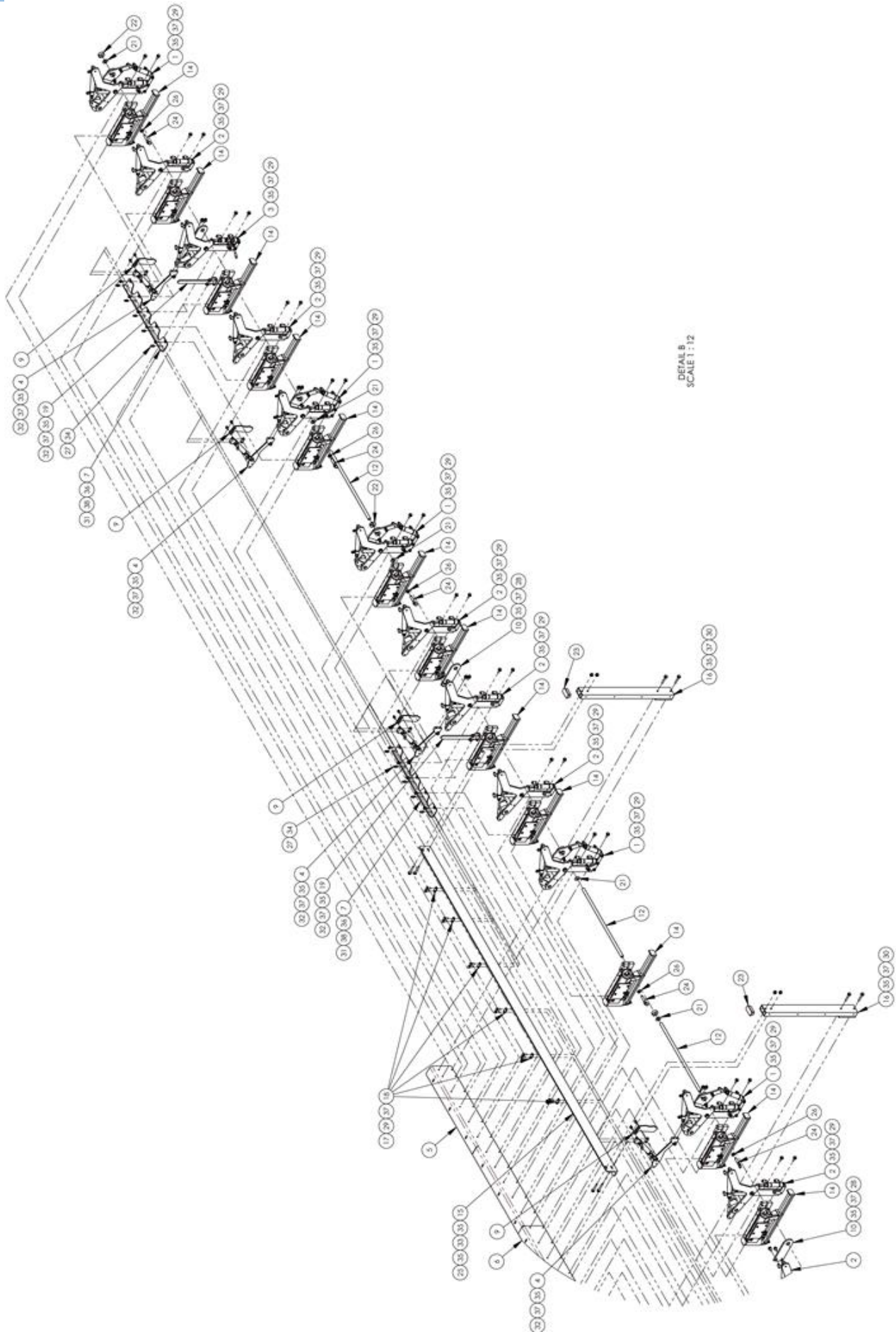

## 1331077 parts list

NO	QTY	PART #	DESCRIPTION
1	8	1331079	COVER STRETCH ROLLER ASSY
2	10	1331080	COVER STRETCH ROLLER ASSY
3	1	1331081	COVER STRETCH ROLLER ASSY
4	6	1331094	TOP CLAMP
5	1	1331166	MOUNT,WHEEL ASSY,INNER
6	1	1331169	MOUNT, WHEEL ASSY, OUTER
7	3	1331231	ANGLE, STAPLE GUN ALIGN
8	1	1331233	ANGLE, STAPLE GUN ALIGN
9	6	1331266	FINGER, LONG CLAMP
10	3	1331312	PLATE, SUPPORT STAPLE
11	1	1331318	ROD,STR,60C 1/2X14.0L
12	3	1331319	ROD,STR,60C, 1/2X18.0L
13	1	1331345	BRKT, VALVE MNT
14	19	1331349	STAPLE GUN ASSY
15	1	1331716	BEAM,CLAMP CYL MTG, LONG
16	2	1331720	WELDMENT,CLAMP FRAME SUPP
17	6	1331724	PLATE,NUT, 1/4-20X2
18	6	1331725	PLATE,WASHER,..266@.75
19	4	1331727	HANDLE
20	*1	AAVSMAY-3	VALVE,SUB MIN,3-WAY SPOOL
21	8	BBT1001	WASHER,THRUST,BRONZE
22	4	CCCL8F	CLAMP COLLAR- 1/2
23	2	MM132-1496	PLUG 1 X 2
24	8	MM8487A31M	PIN,QUICK RELEASE, MOD.
25	4	NEE1/4-20	NUT,ELASTIC LOCK, 1/4-20
26	8	NNJ3/8-16	3/8-16 JAM NUT
27	19	NNJ10-32	NUT,JAM,THIN #10-32
28	6	SSHCO1040	1/4-20 X 5/8 HHCS
29	50	SSHCO1048	1/4-20 X 3/4 HEX CAP
30	4	SSHCO1112	1/4-20 X 1-3/4 HHCS
31	19	SSHC98048	SCREW, HEX CAP #10-32X.75
32	20	SSSC01040	1/4-20 X 5/8" SOC CAP SC
33	4	SSSC01112	1/4-20 X 1-3/4 SOC CAP
34	19	SSSC98040	10-32 X 5/8 SOC CAP
35	76	WWFS1/4	WASHER,FLAT,SAE, 1/4
36	19	WWFS10	WASHER, FLAT, #10, SAE
37	80	WWL1/4	WASHER,LOCK, 1/4
38	19	WWL10	WASHER,LOCK,#10

# 1331078 Short Staple Gun Assembly (B & BC)

AAC Drawing Number 1331078 Rev 7

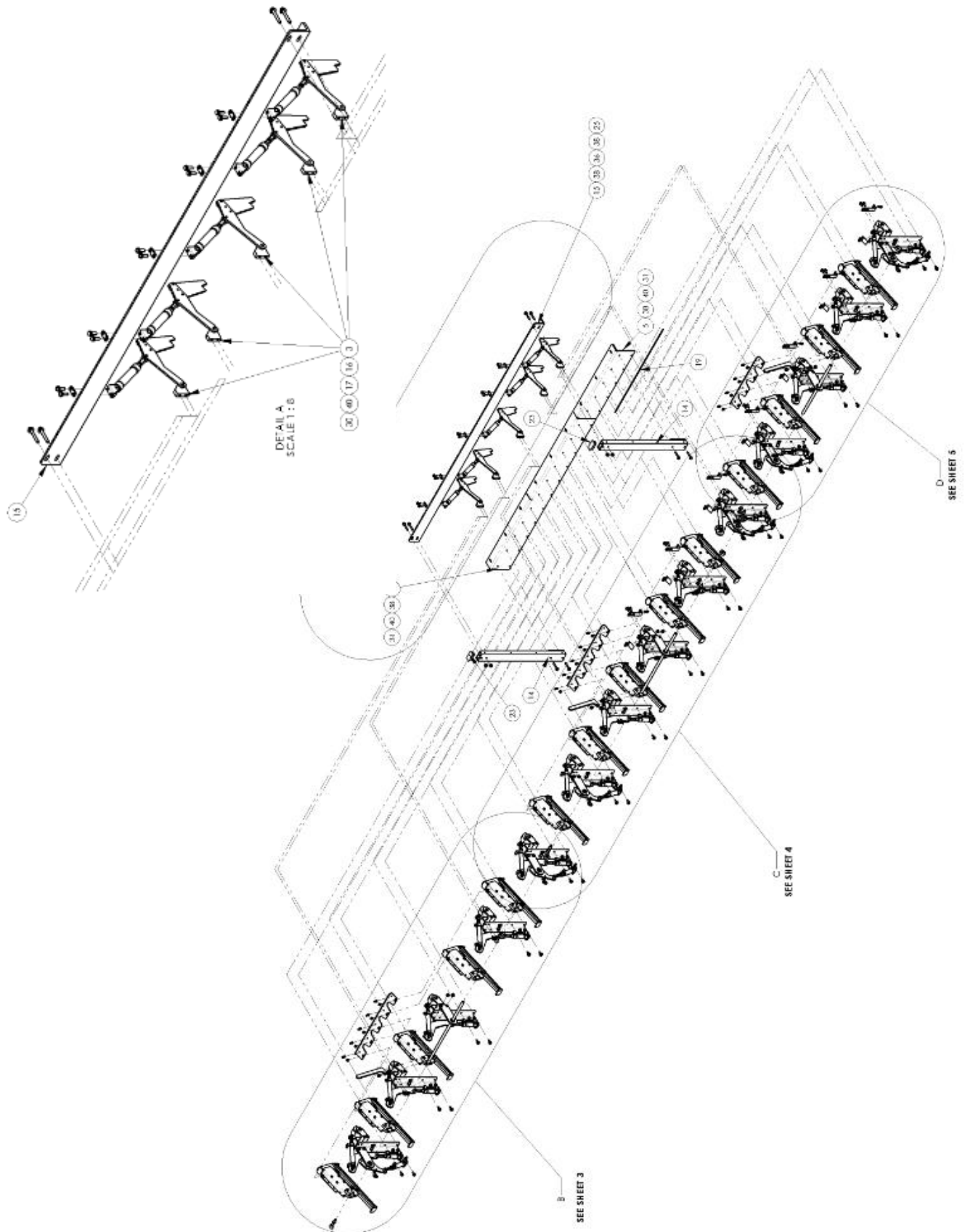

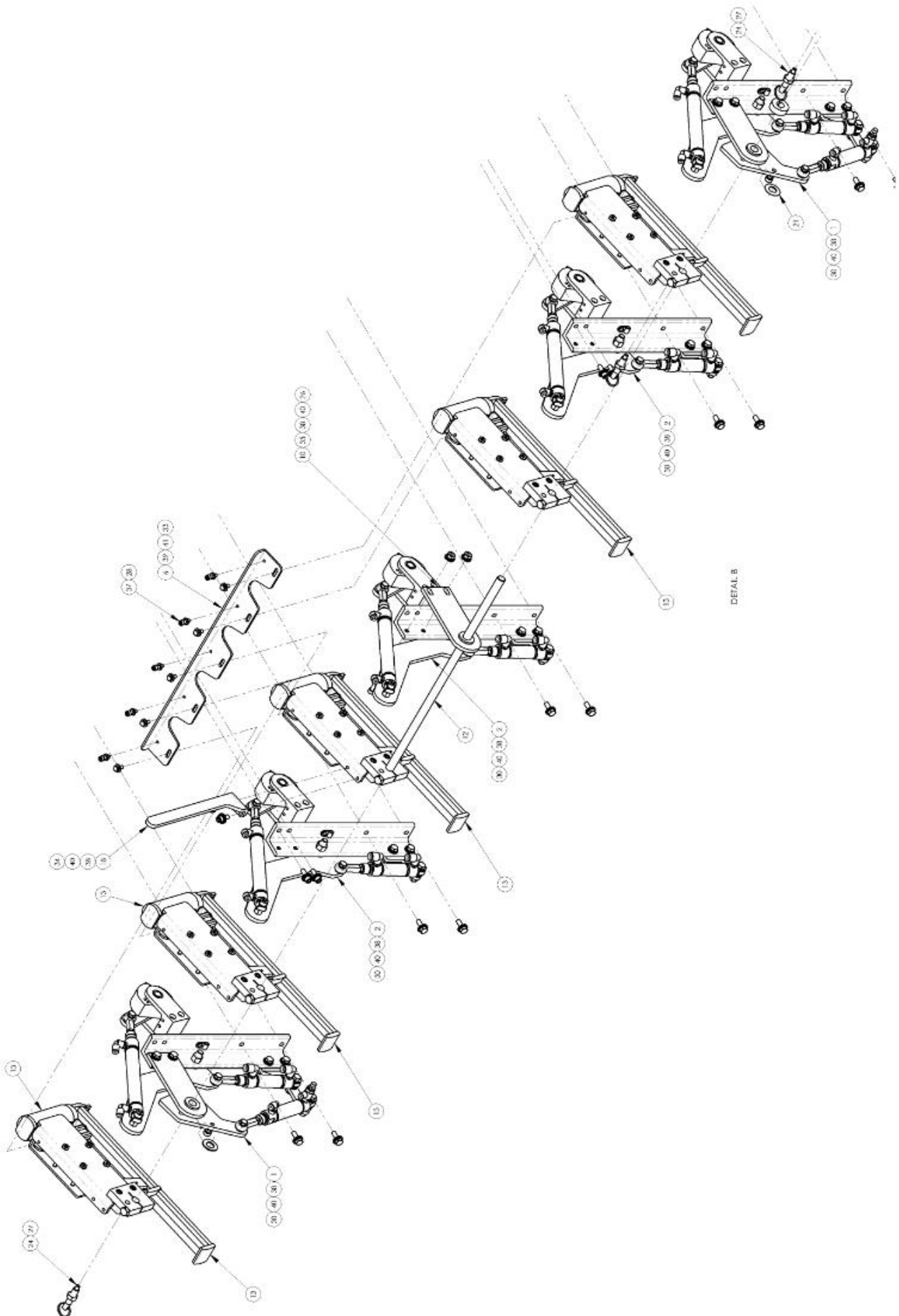

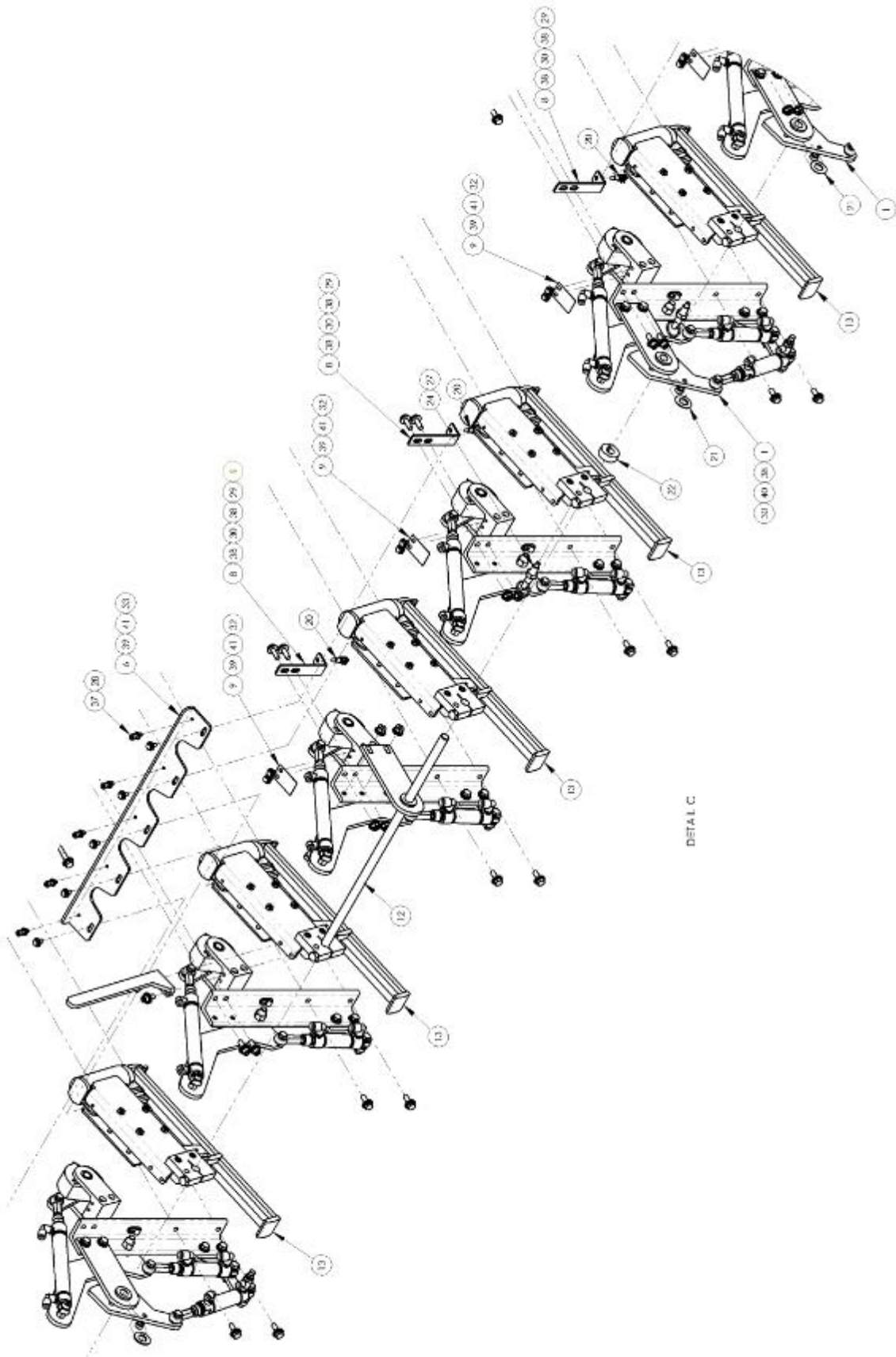

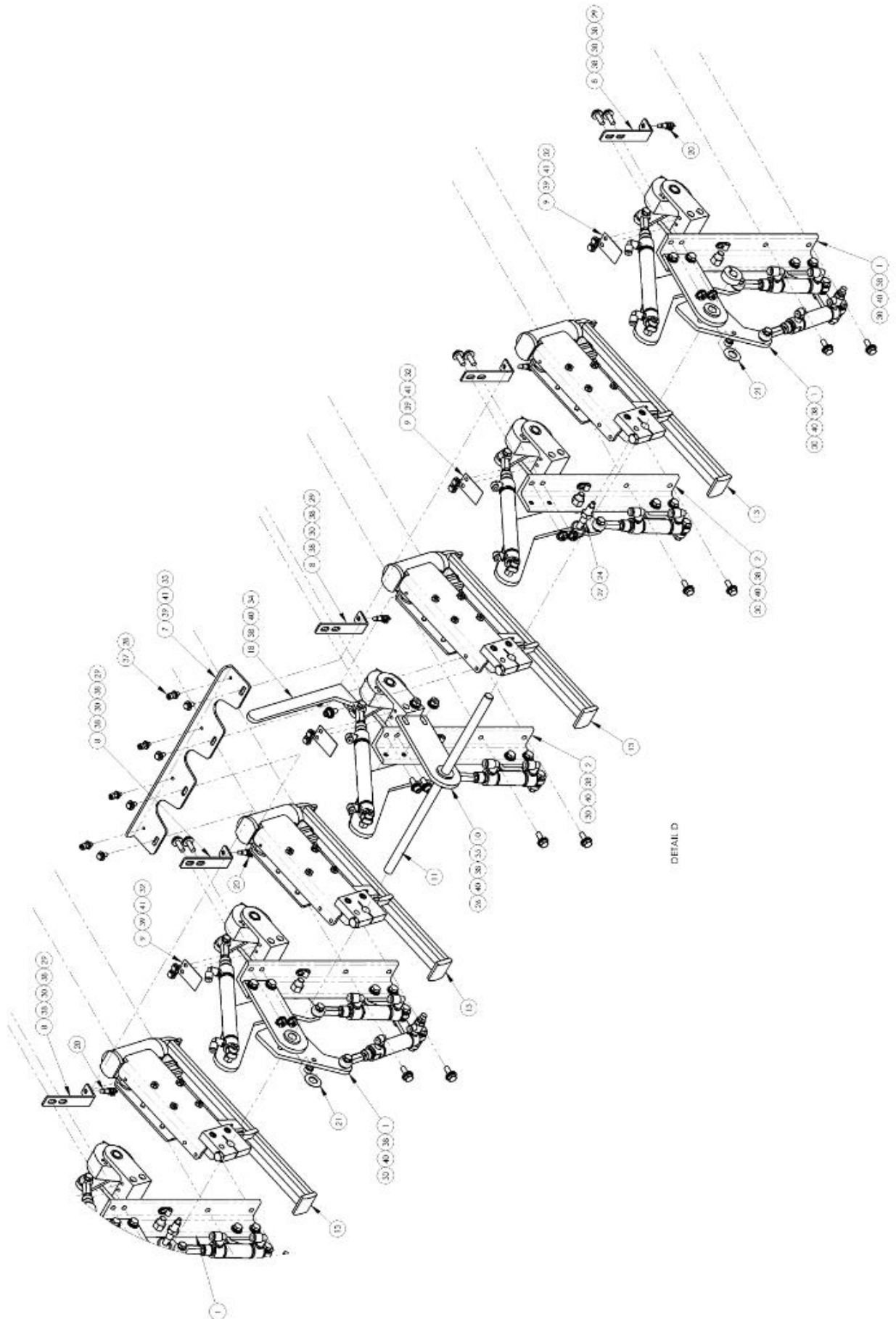

1331078 parts list

ITEM	QTY.	PART NUMBER	DESCRIPTION
1	6	1331079	COVER STRETCH ROLLER ASSY
2	8	1331080	COVER STRETCH ROLLER ASSY
3	5	1331094	TOP CLAMP
4	1	1331167	MOUNT,WHEEL ASSY,INNER
5	1	1331168	MOUNT, WHEEL ASSY, OUTER
6	2	1331231	ANGLE, STAPLE GUN ALIGN
7	1	1331233	ANGLE, STAPLE GUN ALIGN
8	7	1331278	BRACKET, AIR VALVE
9	7	1331279	BRACKET, SWITCH ACTUATOR
10	3	1331312	PLATE, SUPPORT STAPLE
11	1	1331318	ROD,STR,60C1/2X14.0L
12	2	1331319	ROD,STR,60C,1/2X18.0L
13	14	1331349	STAPLE GUN ASSY
14	2	1331720	WELDMENT,CLAMP FRAME SUPP
15	1	1331721	BEAM,CLAMP CYL MTG,SHORT
16	5	1331724	PLATE,NUT,1/4-20X2
17	5	1331725	PLATE,WASHER,.266@.75
18	3	1331727	HANDLE
19	1	AATP1/16B	1/16 ID TUBING, BLUE
20	7	AAVSMV-3	VALVE,SUB MIN,3-WAY SPOOL
21	6	BBT1001	WASHER,THRUST,BRONZE, .5ID
22	3	CCCL8F	CLAMP COLLAR- 1/2
23	2	MM132-1496	PLUG 1 X 2
24	6	MM8487A31M	PIN,QUICK RELEASE, MOD.
25	4	NEE1/4-20	NUT,ELASTIC LOCK,1/4-20
26	6	NNH1/4-20	NUT,HEX,1/4-20
27	6	NNJ3/8-16	3/8-16 JAM NUT
28	14	NNJ10-32	NUT,JAM,THIN #10-32
29	10	NNK1/4-20	NUT,KEP,1/4-20
30	48	SSHCO1048	1/4-20 X 3/4 HEX CAP
31	4	SSHCO1112	1/4-20 X 1-3/4 HHCS
32	14	SSHCO98024	10-32 X 3/8 HEX CAP
33	14	SSHCO98032	10-32X1/2 HEX HD
34	6	SSSCO1040	1/4-20 X 5/8" SOC CAP SC
35	16	SSSCO1048	1/4-20 X 3/4" SOC CAP SC
36	4	SSSCO1112	1/4-20 X 1-3/4 SOC CAP
37	14	SSSCO98040	10-32 X 5/8 SOC CAP
38	82	WWFS1/4	WASHER,FLAT,SAE,1/4
39	28	WWFS10	WASHER, FLAT, #10, SAE
40	63	WWL1/4	WASHER,LOCK, 1/4
41	28	WWL10	WASHER,LOCK,#10

# 1331349 Staple Gun Assembly (all models)

AAC Drawing Number 1331349 Rev 5

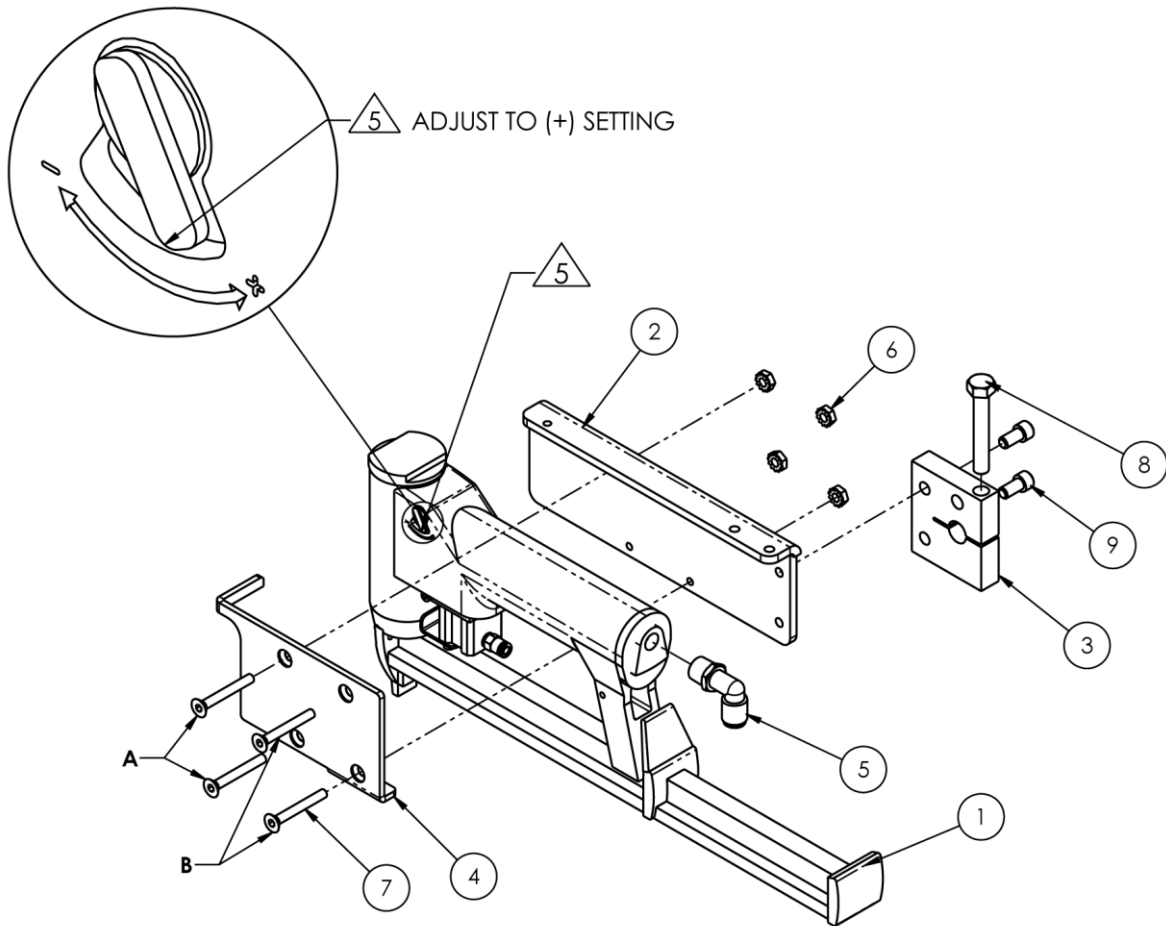

NO.	QTY	PART #	DESCRIPTION
1	1	1331282	STAPLER ASSY WITH CYL
2	1	1331308	PLATE, MNT. STAPLE GUN
3	1	1331310	CLAMP, STAPLE PIVOT
4	1	1331338	PRESSURE PLATE
5	1	AAQME-4-4	ELBOW, MALE, 1/4X1/4NPT
6	4	NNK10-32	KEP NUT, 10-32
7	4	SSFC98096	10-32 X 1-1/2 FLAT ALLEN
8	1	SSHC10128GR8	SCREW, HEX CAP, 5/16-18X2, GR8
9	2	SSSC01032	1/4-20X1/2 SOC CAP

# 1331914 Manual Stapler Assembly (all)

AAC Drawing Number 1331914 Rev 1

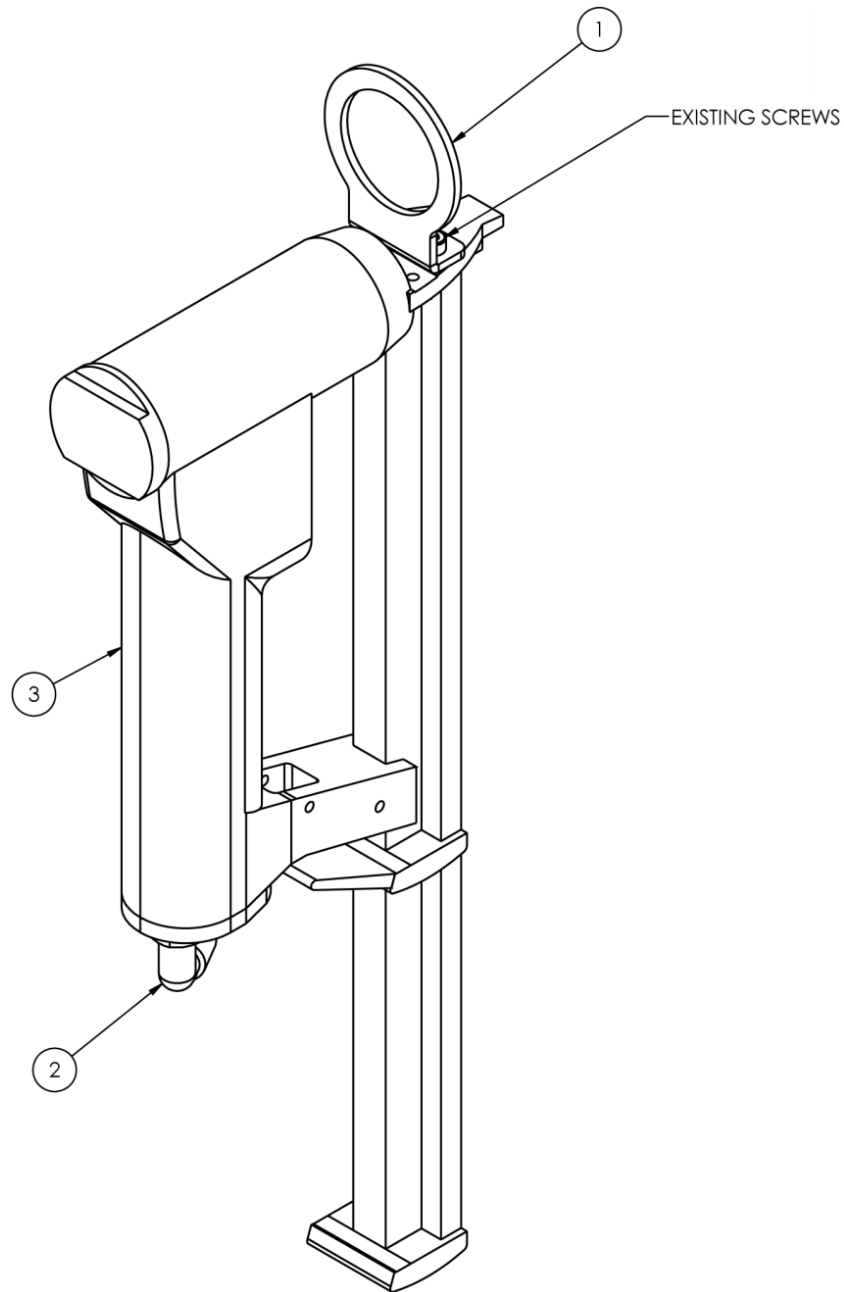

NO.	QTY	PART #	DESCRIPTION
1	1	1331735	BRKT, RING
2	1	AAQME-4-4	ELBOW, MALE, 1/4X1/4NPT
3	1	TU21671B-ALM	STAPLER, UPHOLSTERY

# 1331079 Cover Stretch Roller Assembly (B & BC)

AAC Drawing Number 1331079 Rev 5

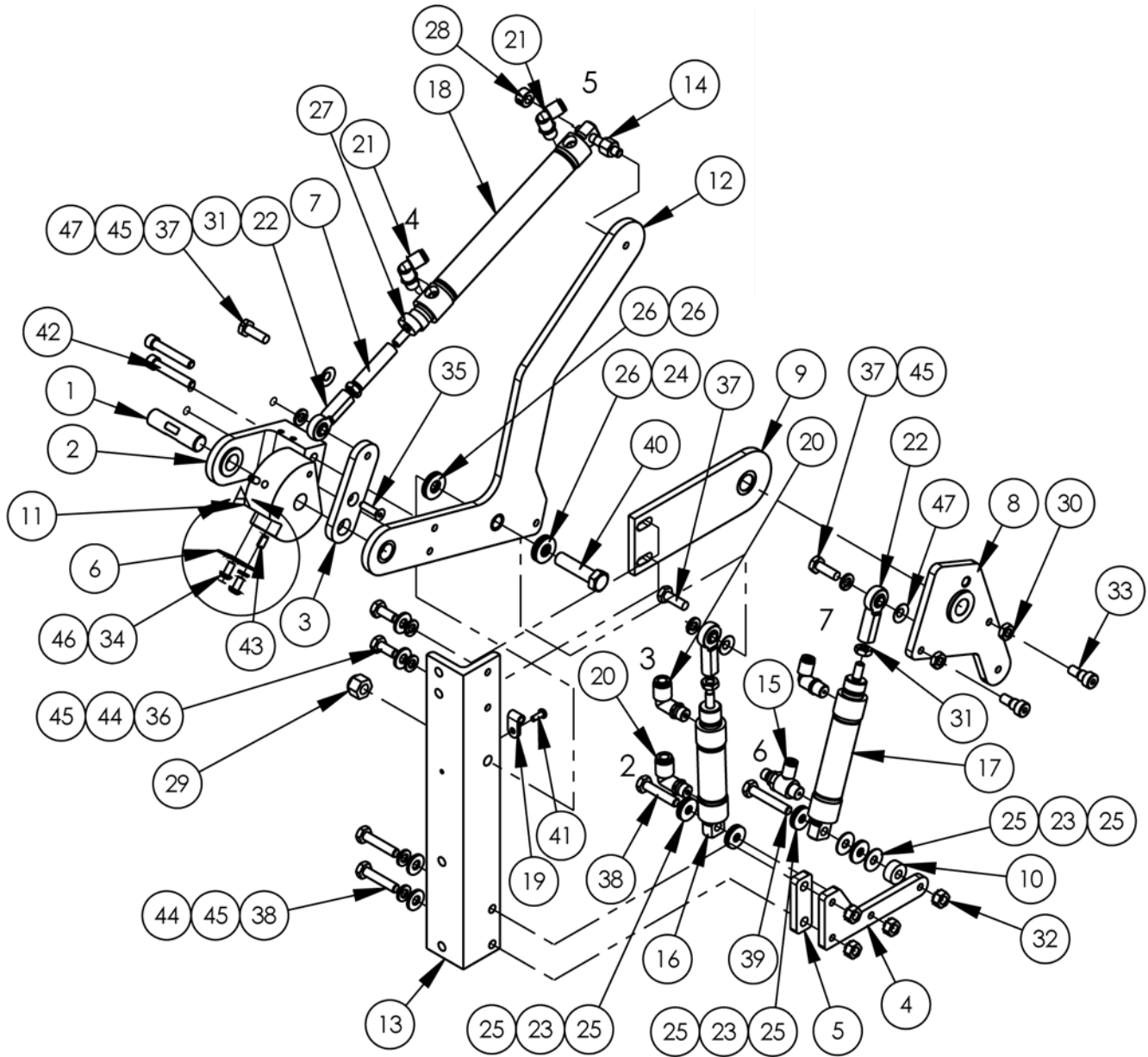

1331079 parts list

NO.	QTY	PART #	DESCRIPTION
1	1	1331204	SHAFT, TENSION WHEEL
2	1	1331205	YOKE, TENSION WHEEL
3	1	1331206	PIVOT ARM, TENSION ROLLER
4	1	1331210	BRKT, AIR CYL
5	1	1331212	SPACER, 1/4X5/8X1.88X1.250
6	1	1331216	BLADE, BORDER TENSION
7	1	1331285	SLEEVE, STOP, TENSION CYL.
8	1	1331311	ARM, STAPLE PIVOT
9	1	1331312	PLATE, SUPPORT STAPLE
10	1	1331313	SPACER, .257IDX.63OD
11	1	1331712	WHEEL, TENSION
12	1	1331714	ARM, TENSION WHEEL
13	1	1331715	TENSION ROLLER MT ANGLE
14	1	1331718	STUD, CYL MTG
15	1	AA198RA508	FLOW CONTROL, 5/32 X 1/8"
16	1	AAC7DP-.5	CYLINDER, AIR, DA
17	1	AAC7DP-1	CYL., AIR, DA 3/4 BORE, 1STR
18	1	AAC7DP-4R	CYL, AIR, DA, 90 DEG PORTS
19	1	AAF3/16	CLAMP, BLACK PLASTIC
20	2	AAQME-4-8	ELBOW, QUICK MALE, 1/4X1/8
21	3	AAQME-5-8	QUICK MALE ELBOW
22	3	BBAW-4	BEARING, ROD END, FEMALE
23	4	BBNTA411	BEARING, THRUST, .250B
24	2	BBNTA613	BEARING, THRUST, 375BORE
25	8	BBTRA411	WASHER, THRUST, STEEL
26	4	BBTRA613	WASHER, THRUST, STL, .375B
27	1	CCCL4F	COLLAR, 1/4, CLAMP
28	1	CCSC41/4	COLLAR, SET 1/4"
29	1	NNE3/8-16	NUT, ELASTIC 3/8-16
30	2	NNJ1/4-20	NUT, HEX, JAM, 1/4-20
31	3	NNJ1/4-28	NUT, HEX, JAM, 1/4-28
32	4	NNK1/4-20	KEP NUT, 1/4-20
33	2	SSAS020016	SHOULDER BOLT 1/4 X 1/4L
34	2	SSBC98024	10-32 X 3/8 BUTTON CAP SC
35	1	SSFC98048	#10-32 X .75 SHCSF
36	2	SSHCO1040	1/4-20 X 5/8 HHCS
37	3	SSHCO1048	1/4-20 X 3/4 HEX CAP
38	3	SSHCO1080	1/4-20 X 1-1/4 HHCS
39	1	SSHCO1096	1/4-20 X 1-1/2 HHCS
40	1	SSHC25096	3/8-16 X 1 1/2 HEX HEAD
41	1	SSPS80024	#6-32 X 3/8 LG PAN HD
42	2	SSSC01096	1/4-20 X 1-1/2 SOC CAP
43	2	SSSS98024	10-32X 3/8 SOC SET SC
44	4	WWFS1/4	WASHER, FLAT, SAE, 1/4
45	7	WWL1/4	WASHER, LOCK, 1/4
46	2	WWL10	WASHER, LOCK, #10, S/S
47	3	WWS307-1	WASHER, SPRING, BELVEL

# 1331080 Cover Stretch Roller Assembly (B & BC)

AAC Drawing Number 1331080 Rev 2

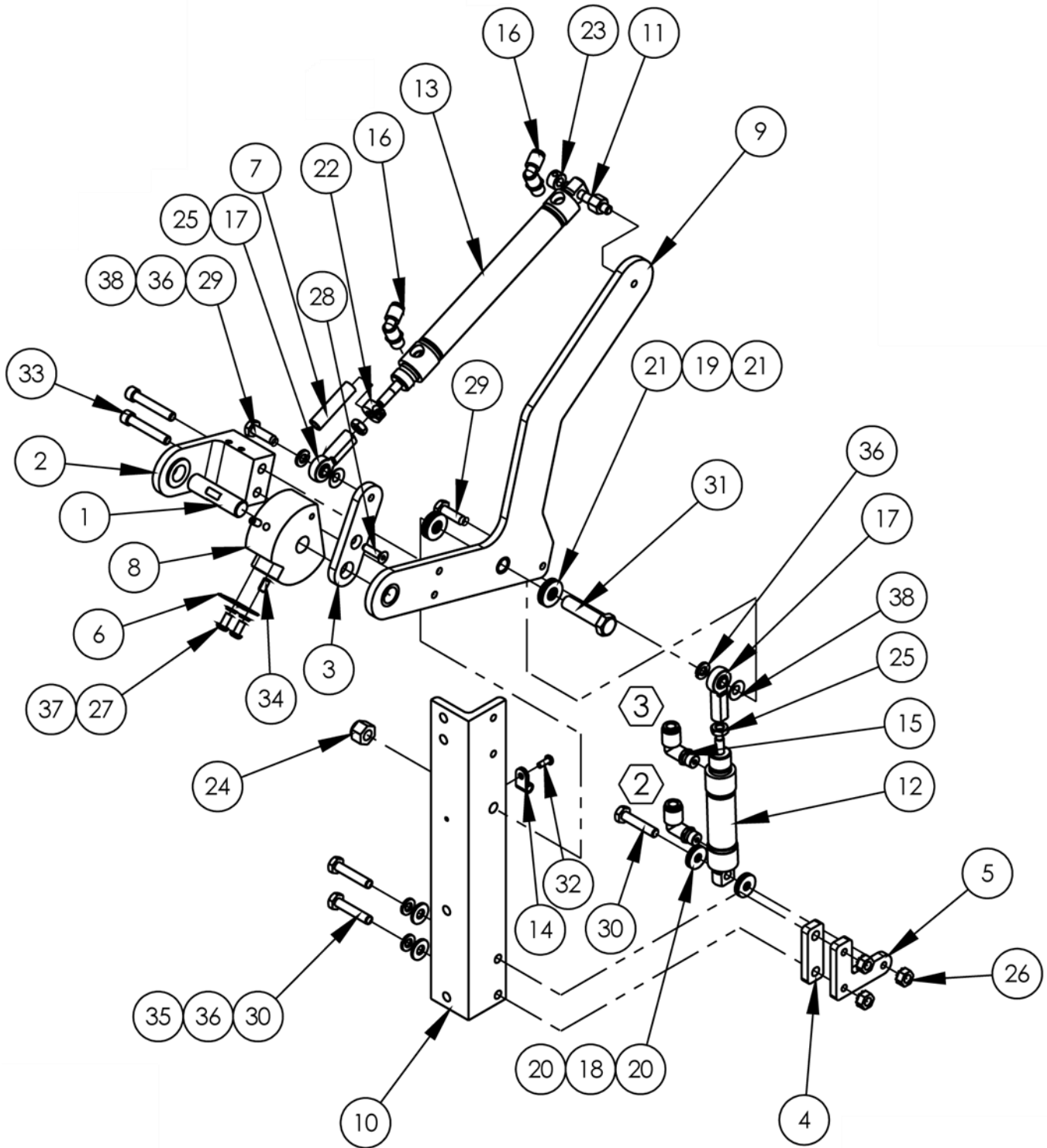

## 1331080 parts list

<b>NO.</b>	<b>QTY</b>	<b>PART #</b>	<b>DESCRIPTION</b>
1	1	1331204	SHAFT, TENSION WHEEL
2	1	1331205	YOKE, TENSION WHEEL
3	1	1331206	PIVOT ARM, TENSION ROLLER
4	1	1331212	SPACER, 1/4X5/8X1.88X1.250
5	1	1331213	BRKT, AIR CYL
6	1	1331216	BLADE, BORDER TENSION
7	1	1331285	SLEEVE, STOP, TENSION CYL.
8	1	1331712	WHEEL, TENSION
9	1	1331714	ARM, TENSION WHEEL
10	1	1331715	TENSION ROLLER MT ANGLE
11	1	1331718	STUD, CYL MTG
12	1	AAC7DP-.5	CYLINDER, AIR, DA
13	1	AAC7DP-4R	CYL, AIR, DA, 90 DEG PORTS
14	1	AAF3/16	CLAMP, BLACK PLASTIC
15	2	AAQME-4-8	ELBOW, QUICK MALE, 1/4X1/8
16	2	AAQME-5-8	QUICK MALE ELBOW
17	2	BBAW-4	BEARING, ROD END, FEMALE
18	2	BBNTA411	BEARING, THRUST, .250B
19	2	BBNTA613	BEARING, THRUST, .375BORE
20	4	BBTRA411	WASHER, THRUST, STEEL
21	4	BBTRA613	WASHER, THRUST, STL, .375B
22	1	CCCL4F	COLLAR, 1/4, CLAMP
23	1	CCSC41/4	COLLAR, SET 1/4"
24	1	NNE3/8-16	NUT, ELASTIC 3/8-16
25	2	NNJ1/4-28	NUT, HEX, JAM, 1/4-28
26	3	NNK1/4-20	KEP NUT, 1/4-20
27	2	SSBC98024	10-32 X 3/8 BUTTON CAP SC
28	1	SSFC98048	#10-32 X .75 SHCSF
29	2	SSHC01048	1/4-20 X 3/4 HEX CAP
30	3	SSHC01080	1/4-20 X 1-1/4 HHCS
31	1	SSHC25096	3/8-16 X 1-1/2 HEX HEAD
32	1	SSPS80024	#6-32 X 3/8 LG PAN HD
33	2	SSSC01096	1/4-20 X 1-1/2 SOC CAP
34	2	SSSS98024	10-32X 3/8 SOC SET SC
35	2	WWFS1/4	WASHER, FLAT, SAE, 1/4
36	4	WWL1/4	WASHER, LOCK, 1/4
37	2	WWL10	WASHER, LOCK, #10, S/S
38	2	WWS307-1	WASHER, SPRING, BELVEL

# 1331081 Cover Stretch Roller Assembly (B & BC)

AAC Drawing Number 1331081 Rev 5

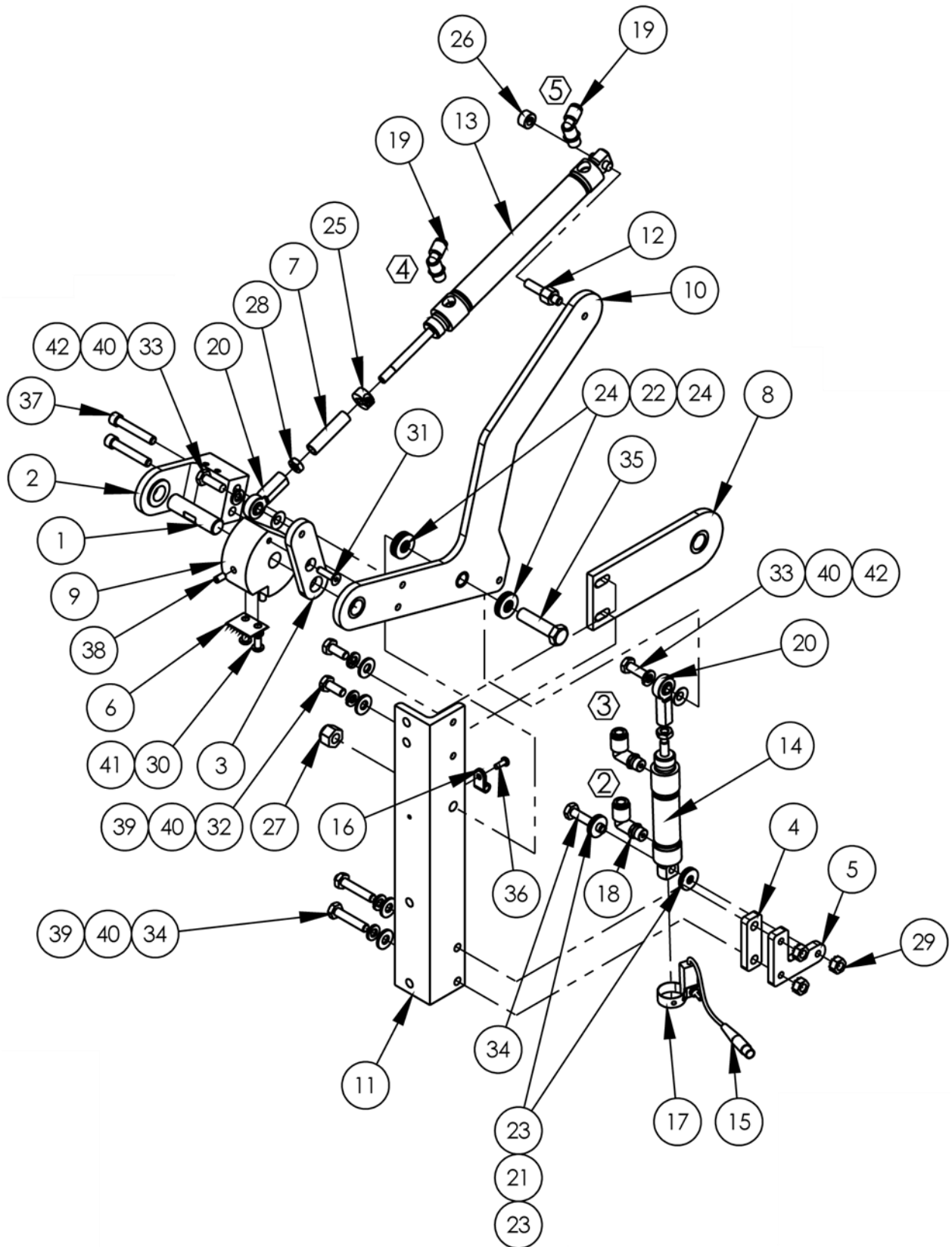

1331081 parts list

NO.	QTY	PART #	DESCRIPTION
1	1	1331204	SHAFT, TENSION WHEEL
2	1	1331205	YOKE, TENSION WHEEL
3	1	1331206	PIVOT ARM, TENSION ROLLER
4	1	1331212	SPACER,1/4X5/8X1.88X1.250
5	1	1331213	BRKT, AIR CYL
6	1	1331216	BLADE, BORDER TENSION
7	1	1331285	SLEEVE,STOP,TENSION CYL.
8	1	1331312	PLATE, SUPPORT STAPLE
9	1	1331712	WHEEL, TENSION
10	1	1331714	ARM,TENSION WHEEL
11	1	1331715	TENSION ROLLER MT ANGLE
12	1	1331718	STUD,CYL MTG
13	1	AAC7DP-4R	CYL,AIR,DA,90 DEG PORTS
14	1	AACM040.5-DXP	CYLINDER,AIR,3/4X1/2 STR
15	1	AAEHSKQ	SWITCH,HALL EFFECT(SMC)
16	1	AAF3/16	CLAMP, BLACK PLASTIC
17	1	AAFD35000	BAND,UNIVERSAL,AAEHSKQ
18	2	AAQME-4-8	ELBOW,QUICK MALE,1/4X1/8
19	2	AAQME-5-8	QUICK MALE ELBOW
20	2	BBAW-4	BEARING,ROD END,FEMALE
21	2	BBNTA411	BEARING,THRUST,.250B
22	2	BBNTA613	BEARING,THRUST,375BORE
23	4	BBTRA411	WASHER,THRUST,STEEL
24	4	BBTRA613	WASHER,THRUST,STL, .375B
25	1	CCCL4F	COLLAR,1/4,CLAMP
26	1	CCSC41/4	COLLAR,SET 1/4"
27	1	NNE3/8-16	NUT, ELASTIC 3/8-16
28	2	NNJ1/4-28	NUT, HEX, JAM, 1/4-28
29	3	NNK1/4-20	KEP NUT, 1/4-20
30	2	SSBC98024	10-32 X 3/8 BUTTON CAP SC
31	1	SSFC98048	#10-32 X .75 SHCSF
32	2	SSHC01040	1/4-20 X 5/8 HHCS
33	2	SSHC01048	1/4-20 X 3/4 HEX CAP
34	3	SSHC01080	1/4-20 X 1-1/4 HHCS
35	1	SSHC25096	3/8-16 X 1 1/2 HEX HEAD
36	1	SSPS80024	#6-32 X 3/8 LG PAN HD
37	2	SSSC01096	1/4-20 X 1-1/2 SOC CAP
38	2	SSSS98024	10-32X 3/8 SOC SET SC
39	4	WWFS1/4	WASHER,FLAT,SAE,1/4
40	6	WWL1/4	WASHER,LOCK,1/4
41	2	WWL10	WASHER,LOCK,#10
42	2	WWS307-1	WASHER,SPRING,BELVEL

# 1331393 Tabletop Assembly (BC & BD)

AAC Drawing Number 1331393 Rev 1

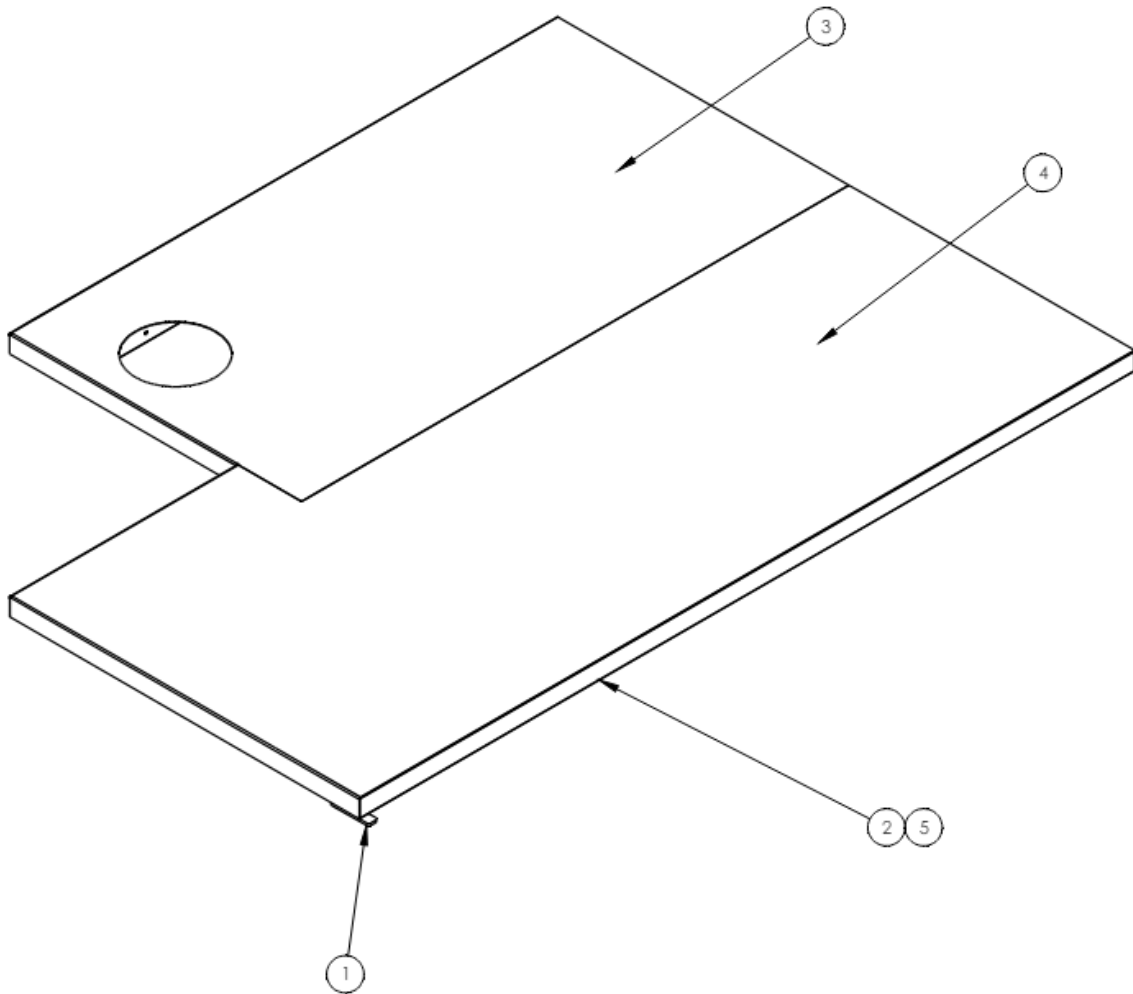

ITEM NO.	QTY.	PART NUMBER	DESCRIPTION
1	2	1331151	BUMPER, TABLE CORNER
2	1	1331395	TABLE TOP FRAME ASSY.
3	1	1331548	PLATE, TOP, FRONT
4	1	1331551	PLATE, TOP, REAR
5	*400IN	ZZZSH-310	TAPE, DOUBLE SIDED, 3/4"W

## 1331140 Tabletop Assembly (B)

AAC Drawing Number 1331140 Rev 3

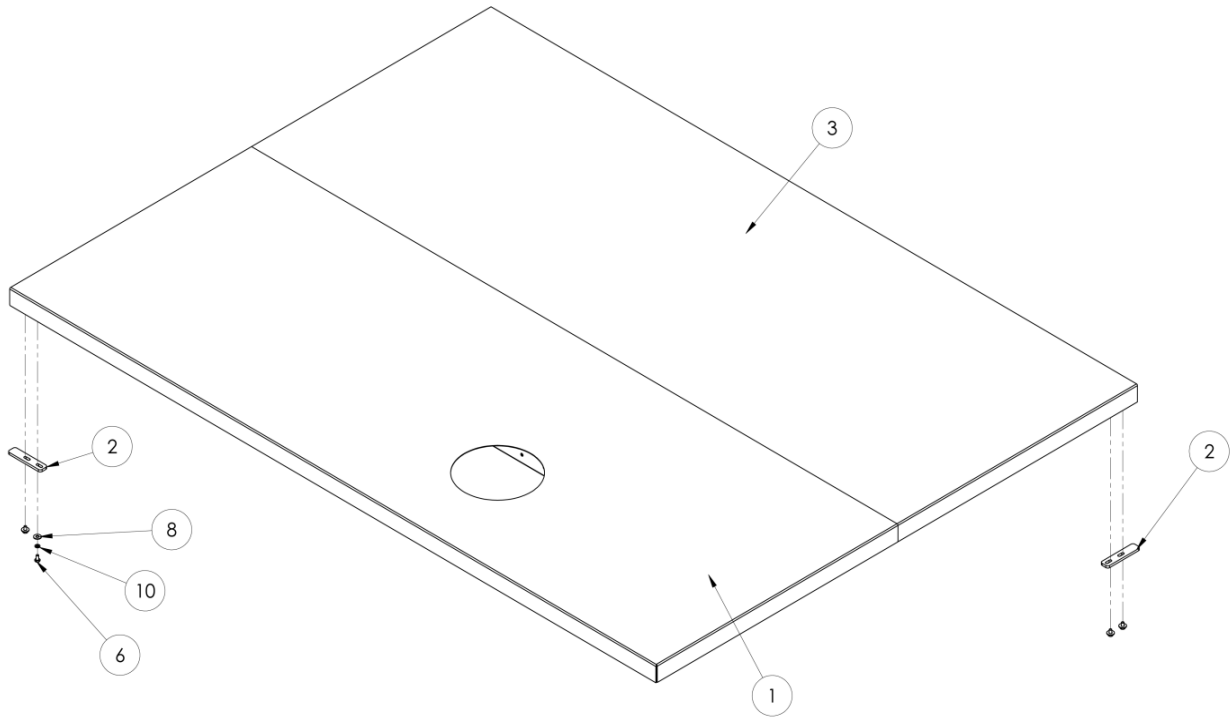

NO	QTY	PART #	DESCRIPTION
1	1	1331147	PLATE, TOP, FRONT
2	2	1331151	BUMPER, TABLE CORNER
3	1	1331163	PLATE, TOP, REAR
4	1	1331395	TABLE TOP FRAME ASSY.
5	1	1331922	CUTOUT TO FULL FRAME
6	4	SSHCO1032	1/4-20 X 1/2 HHCS
7	6	SSHCO1056	1/4-20 X 7/8 HEX CAP
8	4	WWF1/4	WASHER, FLAT, 1/4", COM
9	6	WWFS1/4	WASHER, FLAT, SAE, 1/4
10	10	WWL1/4	WASHER, LOCK, 1/4

# 1331178 Pneumatic Panel (all)

AAC Drawing Number 1331178 Rev 4

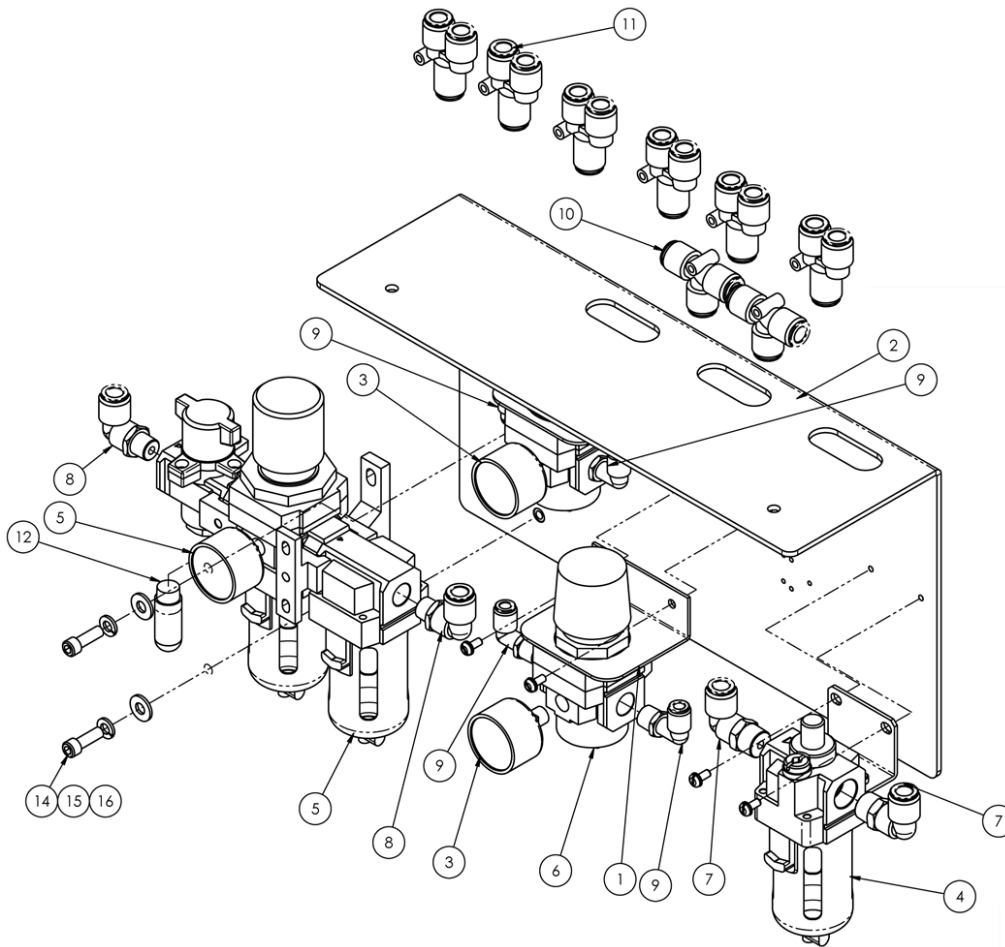

NO.	QTY	PART #	DESCRIPTION
1	2	0411-071	BRKT,REGULATOR
2	1	1331175	BRKT, AIR REGULATOR
3	2	AA198-503	0-30PSI AIR GAGE 1/8NPT
4	1	AA198-509A	LUBRICATOR,AIR,3/8" PORT
5	1	AA198-5110	FILTER/REGULATOR/LOCKOUT
6	2	AA198-RP3	REGULATOR,PRECISION AIR
7	2	AAQME-3-3	MALE ELBOW 3/8 OD TUBE
8	2	AAQME-3-4	MALE ELBOW 3/8OD TUBE
9	4	AAQME-4-4	ELBOW, MALE,1/4X1/4NPT
10	2	AAQUT-3-3	QUICK UNION T 3/8X3/8
11	6	AAQUY-3-3	QUICK UNION Y 3/8 X 3/8
12	1	MMU002A	MUFFLER,PAPER,1/4"
13	6	SSPS90024	#8-32 X 3/8 LG PAN HD
14	2	SSSC01048	1/4-20 X 3/4" SOC CAP SC
15	2	WWFS1/4	WASHER,FLAT,SAE,1/4
16	2	WWL1/4	WASHER,LOCK,1/4
17	6	WWSI8	WASHER,INT. TOOTH,8

# 1331247 Corner Support Assembly, RH (all models)

AAC Drawing Number 1331247 Rev 0

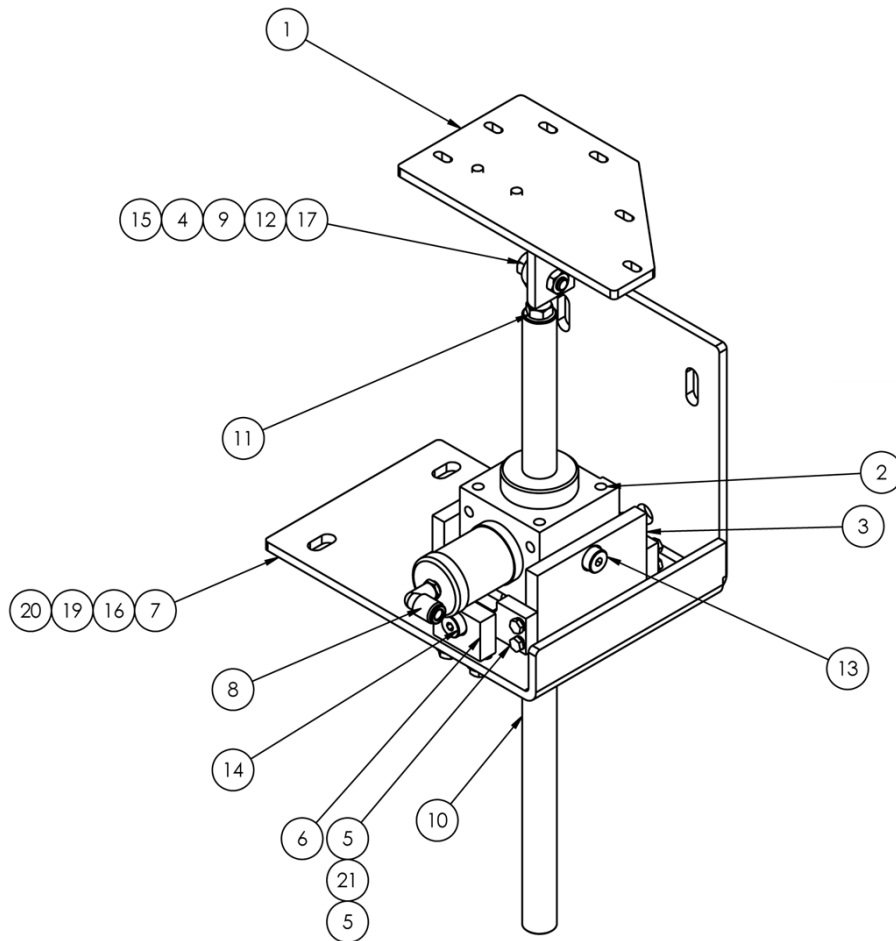

NO.	QTY	PART #	DESCRIPTION
1	1	1331234	BRKT,BRAKE CYL,UPPER
2	1	1331237	ROD BRAKE ASSY, MOD.
3	2	1331239	PLATE,PIVOT,VERTICAL
4	1	1331240	ANGLE,HRPO,3/8X2X3
5	2	1331242	BAR,TIE
6	2	1331244	PLATE,PIVOT HORIZONTAL
7	1	1331248	BRKT,BRAKE CYL, LOWER,RH
8	1	AAQME-4-8	ELBOW,QUICK MALE,1/4X1/8
9	1	MMPHSOM8	BEARING,ROD END,8MM
10	1	MMPSFCT20500	ROD,20MM,500MML
11	1	NNHM8X1.25	M8 X 1.25 HEX NUT
12	1	NNJ5/16-18	NUT,JAM,5/16-18
13	2	SSAS024024	SHOULDER BOLT 3/8 X 3/8L
14	2	SSAS024032	SHULDER BOLT 3/8 X .50L
15	2	SSHC01048	1/4-20 X 3/4 HEX CAP
16	4	SSHC01056	1/4-20 X 7/8 HEX CAP
17	1	SSHC10064	5/16-18 X 1 HHCS
18	8	SSHC98048	SCREW, HEX CAP #10-32X.75
19	6	WWFS1/4	WASHER,FLAT,SAE,1/4
20	6	WWL1/4	WASHER,LOCK,1/4
21	8	WWL10	WASHER,LOCK,#10,S/S

# 1331504 Table Lift Pedal Assembly (all models)

AAC Drawing Number 1331504 Rev 2

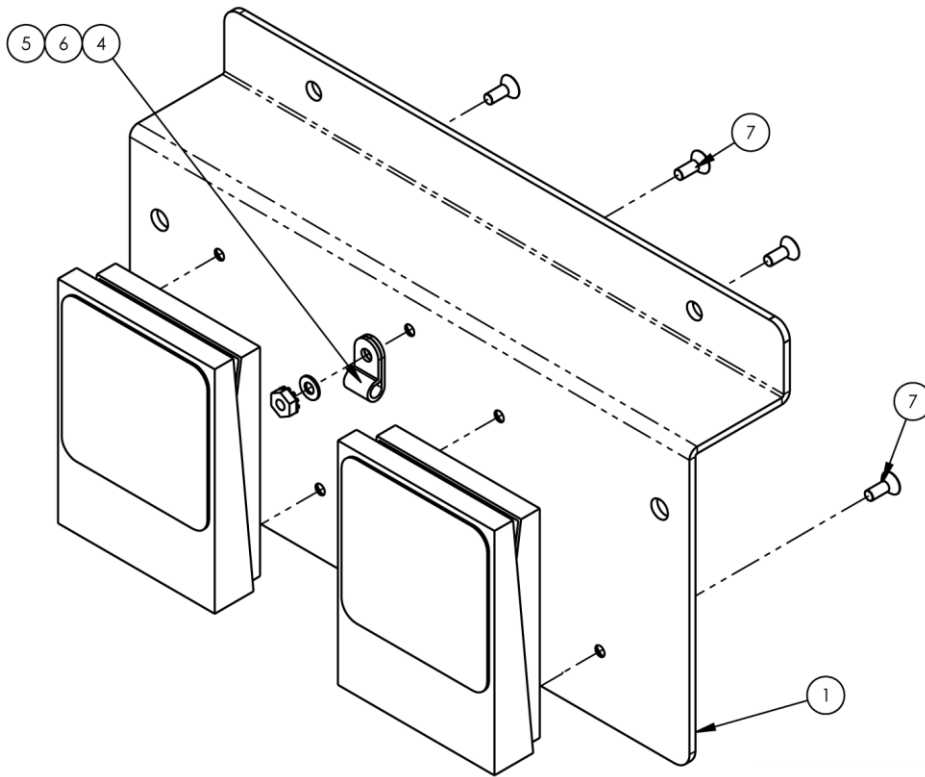

WIRE LIST - UP	
1278-6161	COLOR
N.O.	GREEN
COMMON	RED

WIRE LIST - DOWN	
1278-6161	COLOR
N.O.	WHITE
COMMON	BLACK

NO.	QTY	PART #	DESCRIPTION
1	1	1278-5051A	PLATE, FOOT SW, DUAL
2	2	1278-6161	FOOT SWITCH MODIFICATION
NS	1	12788-502A	CABLE, DUAL FOOT SWITCH
4	1	AAF3/16	CLAMP, BLACK PLASTIC
5	1	WWFS6	WASHER, FLAT, #6
6	1	NNK6-32	KEP NUT, 6-32
7	5	SSFC80024	6-32 X 3/8 FLAT CAP

# 1331900 Control Box (all models)

AAC Drawing Number 1331900 Rev 9

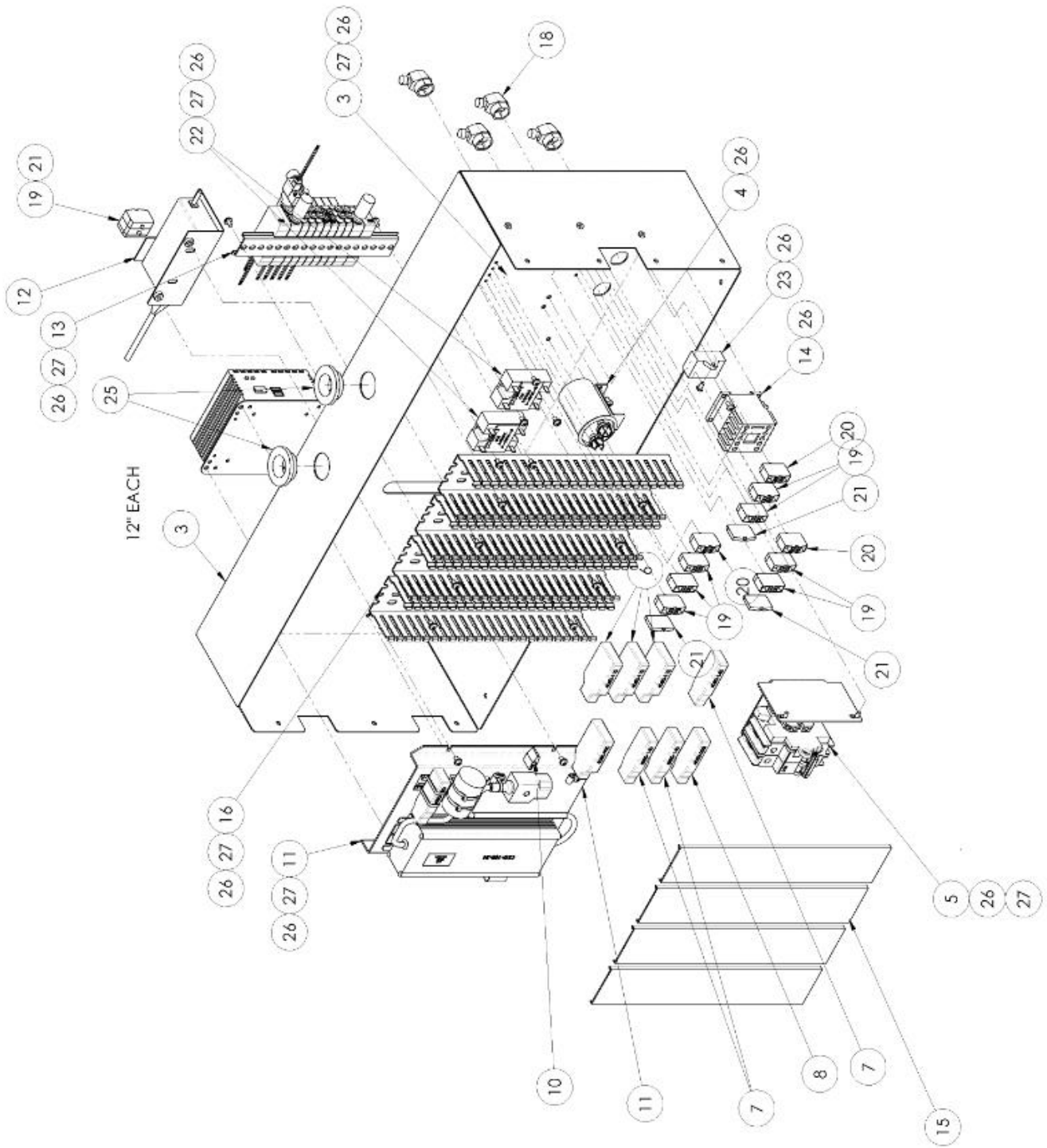

1331900 parts list

ITEM	QTY.	PART NUMBER	DESCRIPTION
1	1	1331-WD	DIAGRAM, WIRING
2	1	13311129	CABLE PACKAGE
3	1	1331901	BACK CONTROL PANEL, BACK-PLATE
4	1	13459004	MOUNTING BRACKET, CAPACIT
5	1	40-320	BREAKER, MAIN PWR, 2P, 20A, WITH
6	3	4080-110	MODULE,QUAD INPUT
7	3	4080-140	MODULE,QUAD OUTPUT
8	1	4080-200	MODULE,AIR PRESSURE
9	1	4080-900	SBUS MODULE, USB GATEWAY, INTERFACE
10	1	4080-940	MODULE,TERMINATOR
11	1	4080-990R	POWER SUPPLY,SBUS,CLASS 2
12	1	4082004	PC POWER BLOCK BRACKET
13	1	AAE1331-7A	HI-FLOW 7 STATION VALVE
14	1	EECA491024	CONTACTOR, MINI, 240V
15	4FT	EEDC2X2	COVER,WIRE DUCT
16	4FT	EEDF2X2	DUCT,WIRE,2X2, MOD
17	1	EEJBC375CG	GATEWAY PC, W-PWR CBL, SERIAL
18	4	FF1724	STRAIN RELIEF
19	9	FF264-341	TERMBLK,WAGO,TOP,DUAL,GRY
20	3	FF264-347	TERMBLK,WAGO,TOP,DUAL,GRN
21	4	FF264-371	TERMBLK,WAGO,TOP,END
22	2	FFD2425F	RELAY,SSR,24VAC,25A
23	1	FFRAV781BW	MODULE, TVS, 240 VAC
24	1	MM74472-010	CAPACITOR, 17.5 MF
25	2	MM9280K33	GROMMET,FLANGE,1.03 ID
26	26	SSPP90020	SCREW,#8-32 X 5/16, PAN HD PHIL
27	21	WWF8	WASHER, FLAT, #8

# 13452000C Square Table Lift Assembly (B & BC)

AAC Drawing Number 9003089 Rev 7

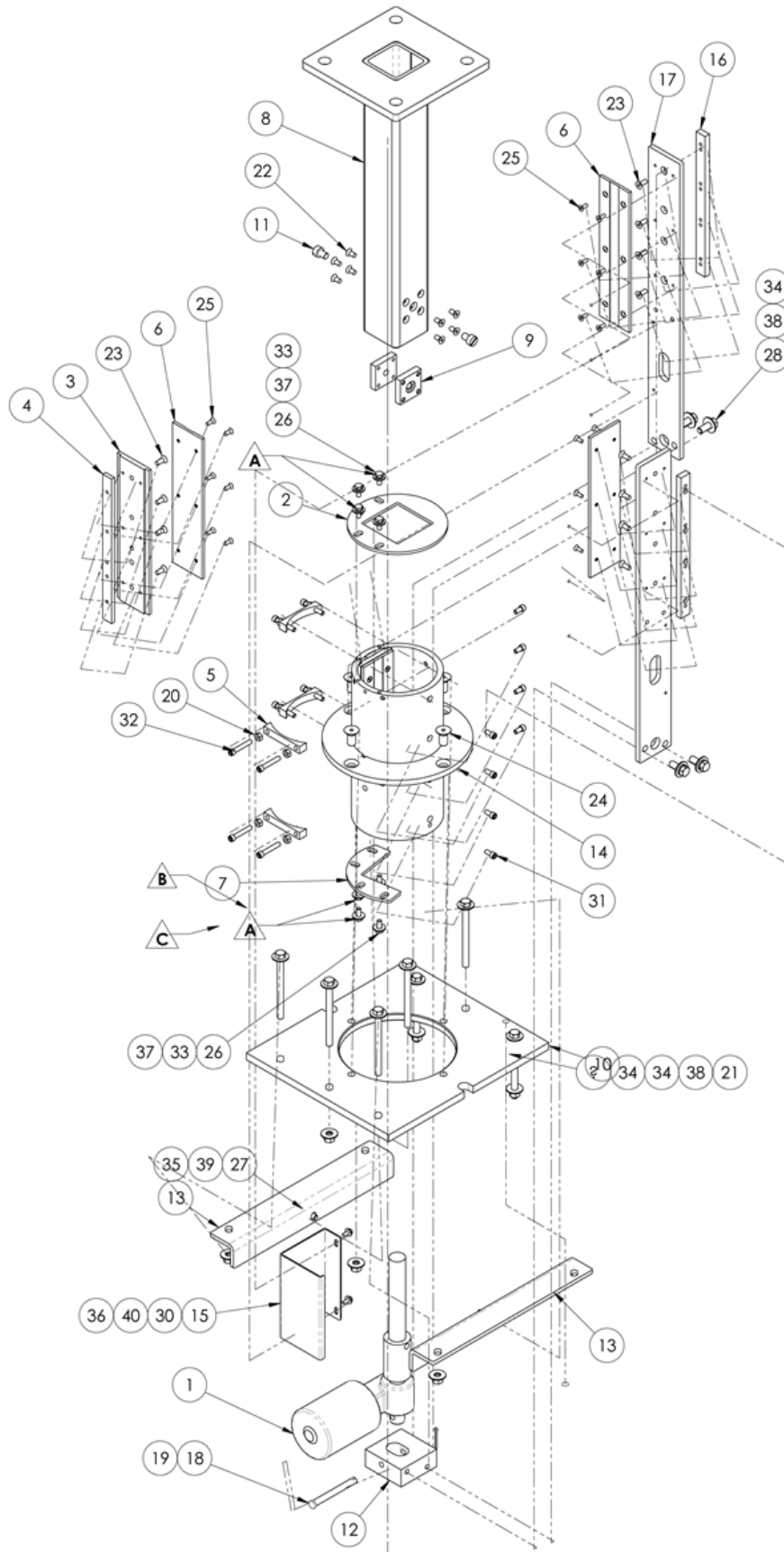

## 13452000C parts list

ITEM NO.	Hardware Shown/QTY.	PART NUMBER	DESCRIPTION
1	1	1322020	ACTUATOR,ELEC,6"
2	1	1345093	BKT,EDGE GUIDE
3	2	1345131	PLATE,SLIDE, ADJ
4	2	1345132	BAR, BRACE,,25 THK
5	4	1345134	SPACER,COLUMN CONCAVE
6	4	1345135	PLATE, SLIDE
7	1	1345136	BKT,LOWER GIB STOP
8	1	1345231	COLUMN ASSY
9	2	1345234	PLATE,ACTUATOR MNTNG,UPR
10	1	13451003	PLATE, COLUMN SUPPORT
11	2	13452004A	PIN, COLUMN
12	1	13452006B	PLATE, ACTUATOR
13	2	13452008A	SUPPORT, COLUMN HUB
14	1	13452020B	COLUMN, HUB ASSY.
15	1	13452023A	COVER, ACTUATOR
16	2	13452040	BAR, BRACE
17	2	13452044A	PLATE,SLIDE SUPPORT
18	1	MM98306A289	PIN,CLEVIS,3/8X3-1/2
19	1	MM98338A445	COTTER PIN, 1/8 X 2 1/2
20	8	NNH1/4-20	NUT,HEX,1/4-20
21	7	NNH3/8-16	NUT,HEX,3/8-16
22	8	SSFC01032	1/4-20 X 1/2 FLAT ALN CAP
23	16	SSFC01040	1/4-20 X 5/8 FLAT ALN CAP
24	4	SSFC45064	1/2-13 X 1 SOC FLAT CAP
25	24	SSFC98032	10-32 X 1/2 FLAT ALLEN CAP
26	8	SSHC01040	1/4-20 X 5/8 HHCS
27	2	SSHC10048	5/16-18 X 3/4 HHCS
28	4	SSHC25064	3/8-16 X 1 HHCS
29	7	SSHC25288	3/8-16X4-1/2,HEX CAP
30	2	SSHC98032	10-32X1/2 HEX HD
31	8	SSSC01032	1/4-20X1/2 SOC CAP
32	8	SSSC01096F	1/4-20 X 1-1/2 SOC CAP
33	8	WWF1/4	WASHER, FLAT, 1/4", COM
34	18	WWF3/8	WASHER,FLAT,3/8 OR 10MM
35	2	WWF5/16	WASHER,FLAT,5/16
36	2	WWF10	WASHER, FLAT, #10, COM
37	8	WWL1/4	WASHER,LOCK,1/4
38	11	WWL3/8	WASHER,LOCK, 3/8
39	2	WWL5/16	WASHER,LOCK, 5/16
40	2	WWL10	WASHER,LOCK,#10

# 1536-069A Footswitch Assembly (all)

AAC Drawing Number 125863A Rev 0

WIRE LIST		
EE24F163	COLOR	FF31F1023
COMMON	WHITE	1
NORMALLY OPEN	BLACK	2

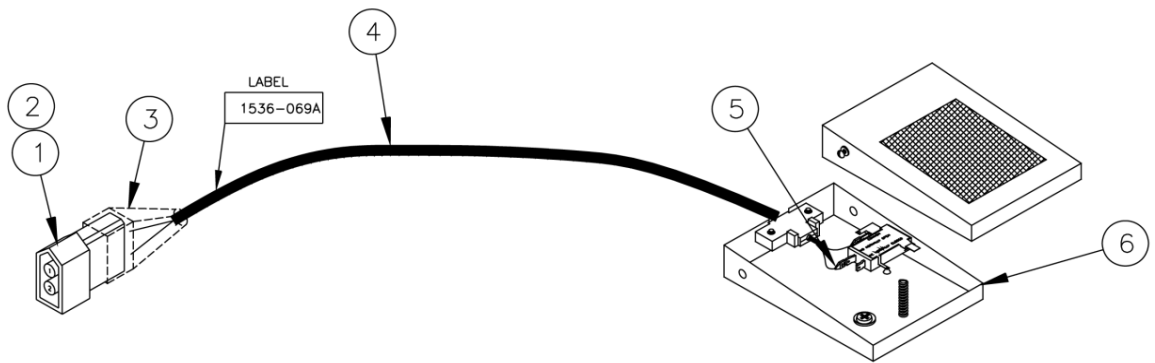
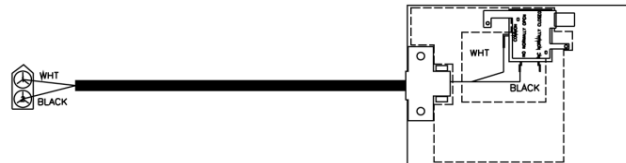

NO.	QTY	PART #	DESCRIPTION
1	1	FF59F1802	2 Pin Male Conn.
2	2	FF31F1022	Male Pin .093
3	2"	ZTH1/2B	Boot Material
4	6'	EE18-2	2 Cond 18AWG
5	2	TT1818	Female Quick Slide
6	1	EE24F163	Threadlite Footswitch

## 26254C Air Reservoir(all models)

AAC Drawing Number 298348B Rev 1

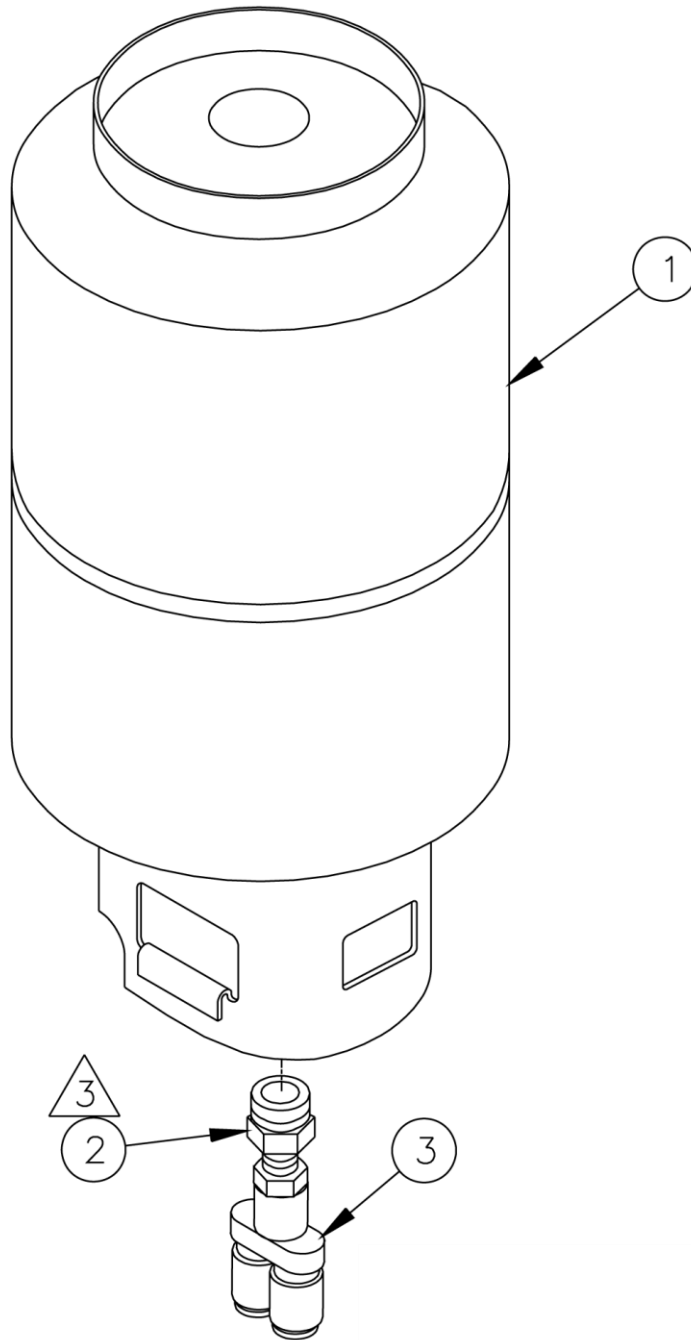

NO.	QTY	PART #	DESCRIPTION
1	1	261007	Air Tank
2	1	MM44605K24	Reducer
3	1	AAQBY-3-2	1/2 x 3/8 "Y"

# 1331559 Long Side Staple Gun Assembly (BD)

AAC Drawing Number 1331559 Rev 0

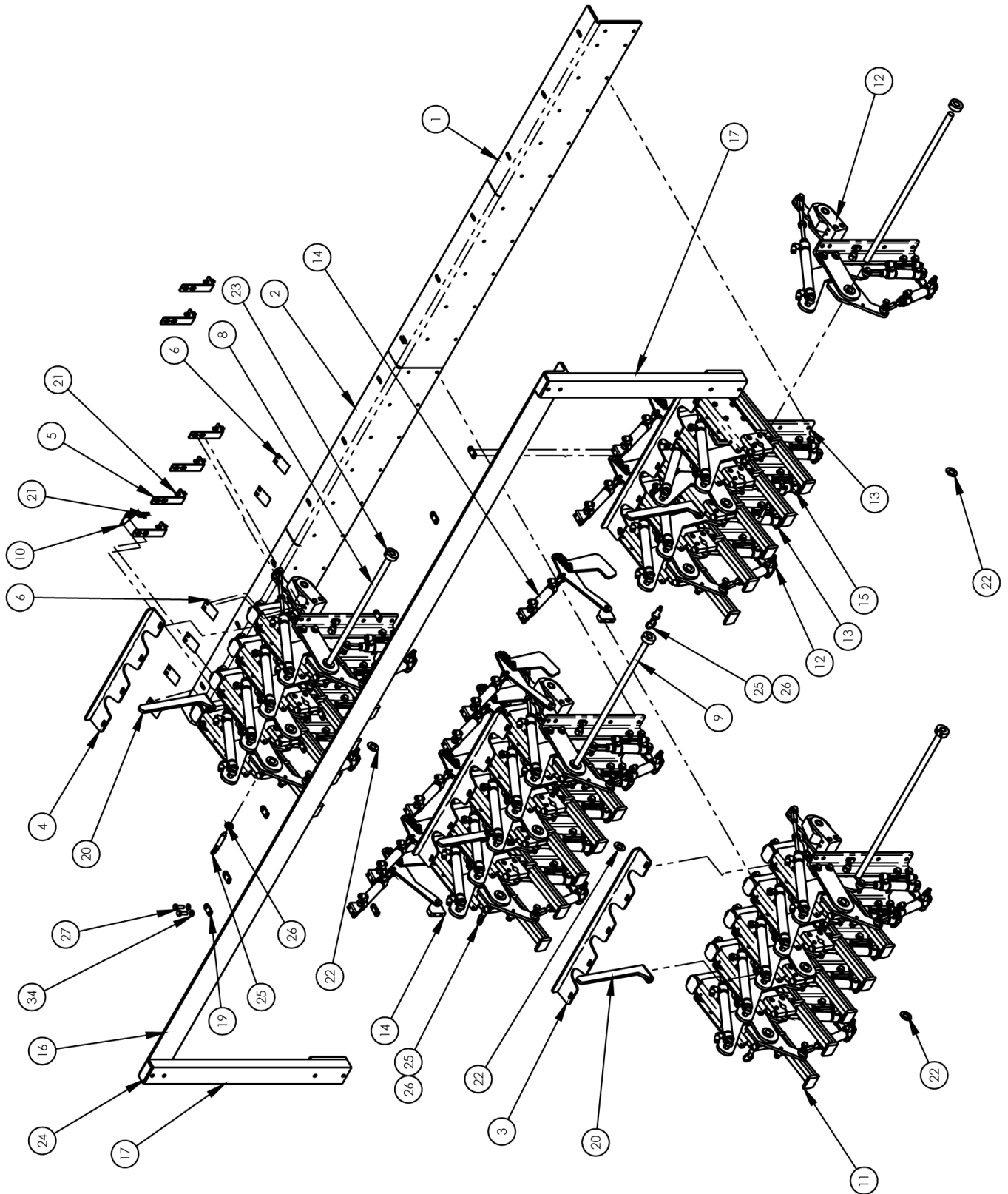

1331559 parts list

NO.	QTY	PART #	DESCRIPTION	NO.	QTY	PART #	DESCRIPTION
1	1	1331166	MOUNT, WHEEL ASSY, INNER	19	8	1331725	PLATE, WASHER, .266@.75
2	1	1331169	MOUNT, WHEEL ASSY, OUTER	20	4	1331727	HANDLE
3	3	1331231	ANGLE, STAPLE GUN ALIGN	21	7	AAVSMV-3	VALVE, SUB MIN, 3-WAY SPOOL
4	1	1331233	ANGLE, STAPLE GUN ALIGN	22	8	BBTT1001	WASHER, THRUST, BRONZE
5	6	1331278	BRACKET, AIR VALVE	23	4	CCCL8F	CLAMP COLLAR- 1/2
6	6	1331279	BRACKET, SWITCH ACTUATOR	24	2	MM132-1496	PLUG 1 X 2
7	3	1331312	PLATE, SUPPORT STAPLE	25	8	MM8487A31M	PIN, QUICK RELEASE, MOD.
8	1	1331318	ROD, STR, 60C1/2X14.0L	26	8	NNJ3/8-16	3/8-16 JAM NUT
9	3	1331319	ROD, STR, 60C, 1/2X18.0L	27	4	SSHC01048	1/4-20 X 3/4 HEX CAP
10	1	1331345	BRKT, VALVE MNT	28	1	SSHC98024	10-32 X 3/8 HEX CAP
11	19	1331349	STAPLE GUN ASSY	29	1	SSHC98048	SCREW, HEX CAP #10-32X.75
12	8	1331558	COVER STRETCH ROLLER ASSY	30	10	SSSC01040	1/4-20 X 5/8" SOC CAP SC
13	10	1331560	COVER STRETCH ROLLER ASSY	31	4	SSSC01048	1/4-20 X 3/4" SOC CAP SC
14	8	1331562	TOP CLAMP	32	16	WWFS1/4	WASHER, FLAT, SAE, 1/4
15	1	1331563	COVER STRETCH ROLLER ASSY	33	3	WWFS10	WASHER, FLAT, #10, SAE
16	1	1331716	BEAM, CLAMP CYL MTG, LONG	34	18	WWL1/4	WASHER, LOCK, 1/4
17	2	1331720	WELDMENT, CLAMP FRAME SUPP	35	3	WWL10	WASHER, LOCK, #10
18	8	1331724	PLATE, NUT, 1/4-20X2				

# 1331564 Short Staple Gun Assembly (BD)

AAC Drawing Number 1331564 Rev 0

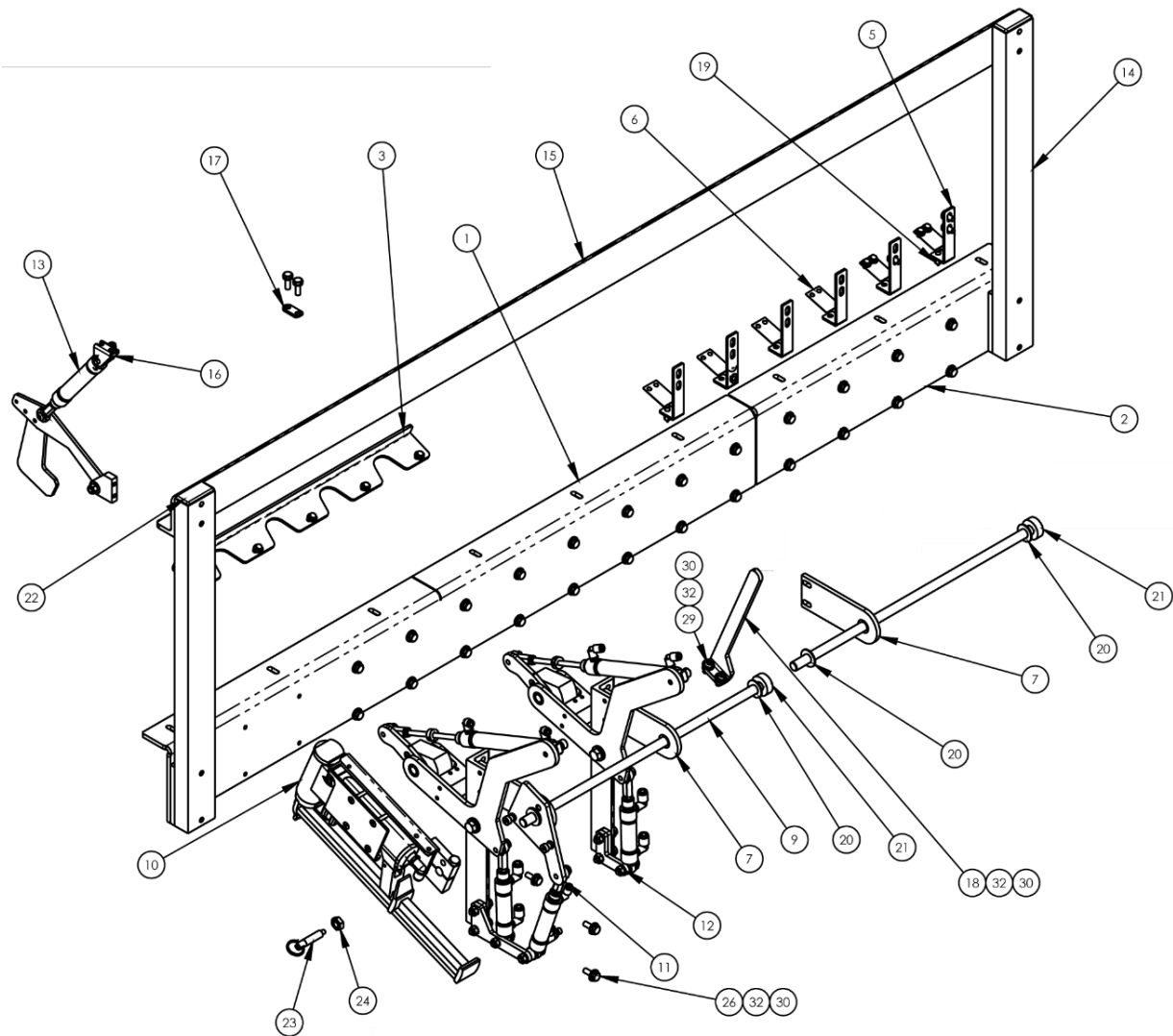

NO.	QTY	PART #	DESCRIPTION	NO.	QTY	PART #	DESCRIPTION
1	1	1331167	MOUNT,WHEEL ASSY,INNER	18	3	1331727	HANDLE
2	1	1331168	MOUNT, WHEEL ASSY, OUTER	19	6	AAVSMVAV-3	VALVE,SUB MIN,3-WAY SPOOL
3	2	1331231	ANGLE, STAPLE GUN ALIGN	20	6	BBTT1001	WASHER,THRUST,BRONZE
4	1	1331233	ANGLE, STAPLE GUN ALIGN	21	3	CCCL8F	CLAMP COLLAR- 1/2
5	6	1331278	BRACKET, AIR VALVE	22	2	MM132-1496	PLUG 1 X 2
6	6	1331279	BRACKET, SWITCH ACTUATOR	23	6	MM8487A31M	PIN,QUICK RELEASE, MOD.
7	2	1331312	PLATE, SUPPORT STAPLE	24	6	NNJ3/8-16	3/8-16 JAM NUT
8	1	1331318	ROD,STR,60C1/2X14.0L	25	3	SSHCO1032	1/4-20 X 1/2 HHCS
9	2	1331319	ROD,STR,60C,1/2X18.0L	26	30	SSHCO1048	1/4-20 X 3/4 HEX CAP
10	14	1331349	STAPLE GUN ASSY	27	4	SSHCO98024	10-32 X 3/8 HEX CAP
11	6	1331558	COVER STRETCH ROLLER ASSY	28	10	SSHCO98032	10-32X1/2 HEX HD
12	8	1331560	COVER STRETCH ROLLER ASSY	29	6	SSSC01040	1/4-20 X 5/8" SOC CAP SC
13	5	1331562	TOP CLAMP	30	39	WWFS1/4	WASHER,FLAT,SAE,1/4
14	2	1331720	WELDMNT,CLAMP FRAME SUPP	31	14	WWFS10	WASHER, FLAT, #10, SAE
15	1	1331721	BEAM,CLAMP CYL MTG,SHORT	32	43	WWL1/4	WASHER,LOCK,1/4
16	5	1331724	PLATE,NUT,1/4-20X2	33	14	WWL10	WASHER,LOCK,#10
17	5	1331725	PLATE,WASHER,.266@.75				

# 1331558 Cover Stretch Roller Assembly (BD)

AAC Drawing Number 1331558 Rev 0

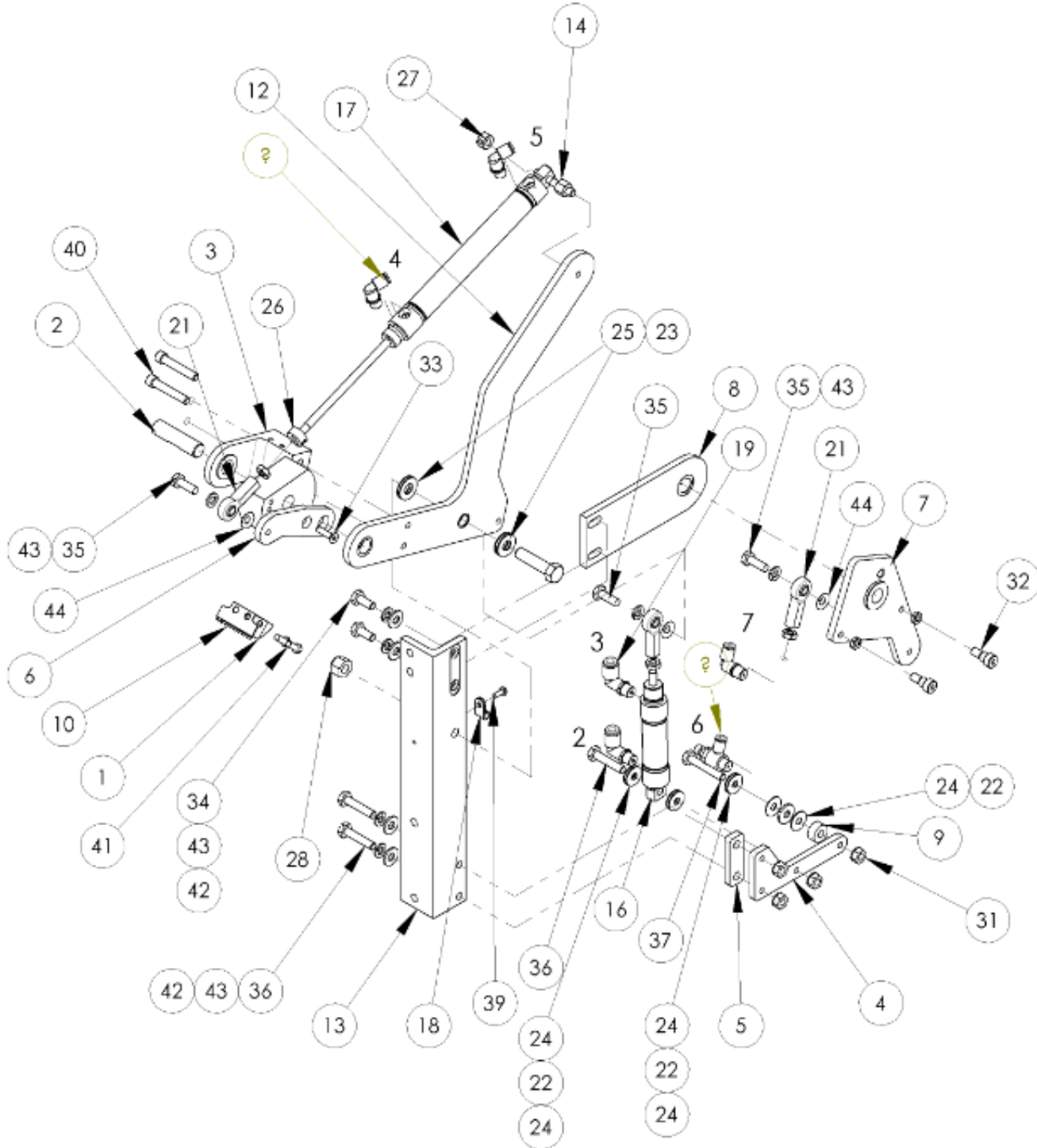

## 1331558 parts list

ITEM	QTY	PART NUMBER	DESCRIPTION
1	1	1331125	BLOCK, FILLER, PULL WHEEL
2	1	1331204	SHAFT, TENSION WHEEL
3	1	1331205	YOKE, TENSION WHEEL
4	1	1331210	BRKT, AIR CYL
5	1	1331212	SPACER,1/4X5/8X1.88X1.25O
6	1	1331287	PIVOT ARM, TENSION ROLLER
7	1	1331311	ARM, STAPLE PIVOT
8	1	1331312	PLATE, SUPPORT STAPLE
9	1	1331313	SPACER, .257IDX.63OD
10	1	1331579	BLADE, BORDER TENSION
11	1	1331712	WHEEL, TENSION
12	1	1331714	ARM,TENSION WHEEL
13	1	1331715	TENSION ROLLER MT ANGLE
14	1	1331718	STUD,CYL MTG
15	1	AA198RA508	FLOW CONTROL,5/32 X 1/8"
16	1	AAC7DP-.5	CYLINDER,AIR,DA
17	1	AAC7DP-4R	CYL,AIR,DA,90 DEG PORTS
18	1	AAF3/16	CLAMP, BLACK PLASTIC, 3/16
19	2	AAQME-4-8	QUICK MALE ELBOW, 1/4T
20	3	AAQME-5-8	QUICK MALE ELBOW
21	3	BBAW-4	BEARING,ROD END,FEMALE
22	4	BBNTA411	BEARING,THRUST,.250B
23	2	BBNTA613	BEARING,THRUST,.375BORE
24	8	BBTRA411	WASHER,THRUST,STEEL
25	4	BBTRA613	WASHER,THRUST,STL, .375B
26	1	CCCL4F	COLLAR,1/4,CLAMP
27	1	CCSC41/4	COLLAR,SET 1/4"
28	1	NNE3/8-16	NUT, ELASTIC 3/8-16
29	3	NNJ1/4-28	1/4-28 HEX JAM NUT
30	2	NNJ10-24	NUT,JAM,THIN #10-24
31	4	NNK1/4-20	KEP NUT, 1/4-20
32	2	SSAS020016	SHOULDER BOLT 1/4 X 1/4L
33	1	SSFC98048	#10-32 X .75 SHCSF
34	2	SSHCO1040	1/4-20 X 5/8 HHCS
35	3	SSHCO1048	1/4-20 X 3/4 HEX CAP
36	3	SSHCO1080	HEX HEAD 1/4-20 X 1-1/4
37	1	SSHCO1096	1/4-20 X 1-1/2 HHCS
38	1	SSHCO25096	3/8-16 X 1-1/2 HEX HEAD
39	1	SSPS80024	#6-32 X 3/8 PAN HD SLOT
40	2	SSSC01096	1/4-20 X 1-1/2 SOC CAP
41	2	SSSC98032L	SCREW, SOCKET CAP
42	4	WWFS1/4	WASHER,FLAT,SAE,1/4
43	7	WWL1/4	WASHER,LOCK, 1/4
44	3	WWS307-1	WASHER,SPRING,BELVEL

# 1331560 Cover Stretch Roller Assembly (BD)

AAC Drawing Number 1331560 Rev 0

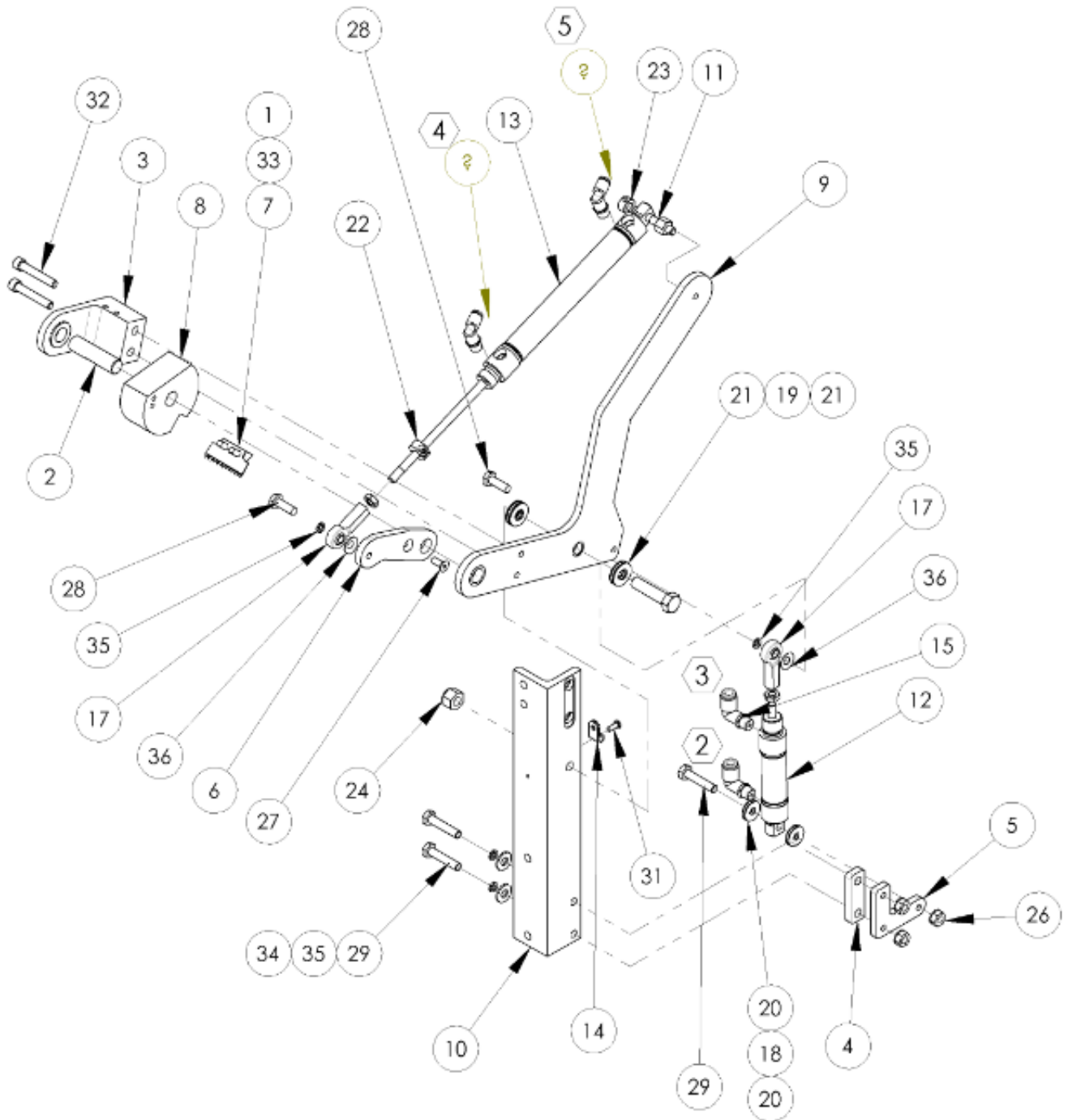

## 1331560 Parts list

ITEM	QTY	PART NUMBER	DESCRIPTION
1	1	1331125	BLOCK, FILLER, PULL WHEEL
2	1	1331204	SHAFT, TENSION WHEEL
3	1	1331205	YOKE, TENSION WHEEL
4	1	1331212	SPACER, 1/4X5/8X1.88X1.250
5	1	1331213	BRKT, AIR CYL
6	1	1331287	PIVOT ARM, TENSION ROLLER
7	1	1331579	BLADE, BORDER TENSION
8	1	1331712	WHEEL, TENSION
9	1	1331714	ARM, TENSION WHEEL
10	1	1331715	TENSION ROLLER MT ANGLE
11	1	1331718	STUD, CYL MTG
12	1	AAC7DP-.5	CYLINDER, AIR, DA
13	1	AAC7DP-4R	CYL, AIR, DA, 90 DEG PORTS
14	1	AAF3/16	CLAMP, BLACK PLASTIC, 3/16 DIA
15	2	AAQME-4-8	QUICK MALE ELBOW, 1/4T
16	2	AAQME-5-8	QUICK MALE ELBOW
17	2	BBAW-4	BEARING, ROD END, FEMALE
18	2	BBNTA411	BEARING, THRUST, .250B
19	2	BBNTA613	BEARING, THRUST, .375BORE
20	4	BBTRA411	WASHER, THRUST, STEEL
21	4	BBTRA613	WASHER, THRUST, STL, .375B
22	1	CCCL4F	COLLAR, 1/4, CLAMP
23	1	CCSC41/4	COLLAR, SET 1/4"
24	1	NNE3/8-16	NUT, ELASTIC 3/8-16
25	2	NNJ1/4-28	NUT, HEX, JAM, 1/4-28
26	3	NNK1/4-20	KEP NUT, 1/4-20
27	1	SSFC98032	10-32 X 1/2 FLAT ALLEN CAP
28	2	SSHC01048	1/4-20 X 3/4 HEX CAP
29	3	SSHC01080	HEX HEAD 1/4-20 X 1-1/4
30	1	SSHC25096	3/8-16 X 1-1/2 HEX HEAD
31	1	SSPS80024	#6-32 X 3/8 LG PAN HD
32	2	SSSC01096	1/4-20 X 1-1/2 SOC CAP
33	2	SSSC98032L	SCREW, SOCKET CAP
34	2	WWFS1/4	WASHER, FLAT, SAE, 1/4
35	4	WWL10	WASHER, LOCK, #10
36	2	WWS307-1	WASHER, SPRING, BELVEL

# 1331563 Cover Stretch Roller Assembly (BD)

AAC Drawing Number 1331563 Rev 0

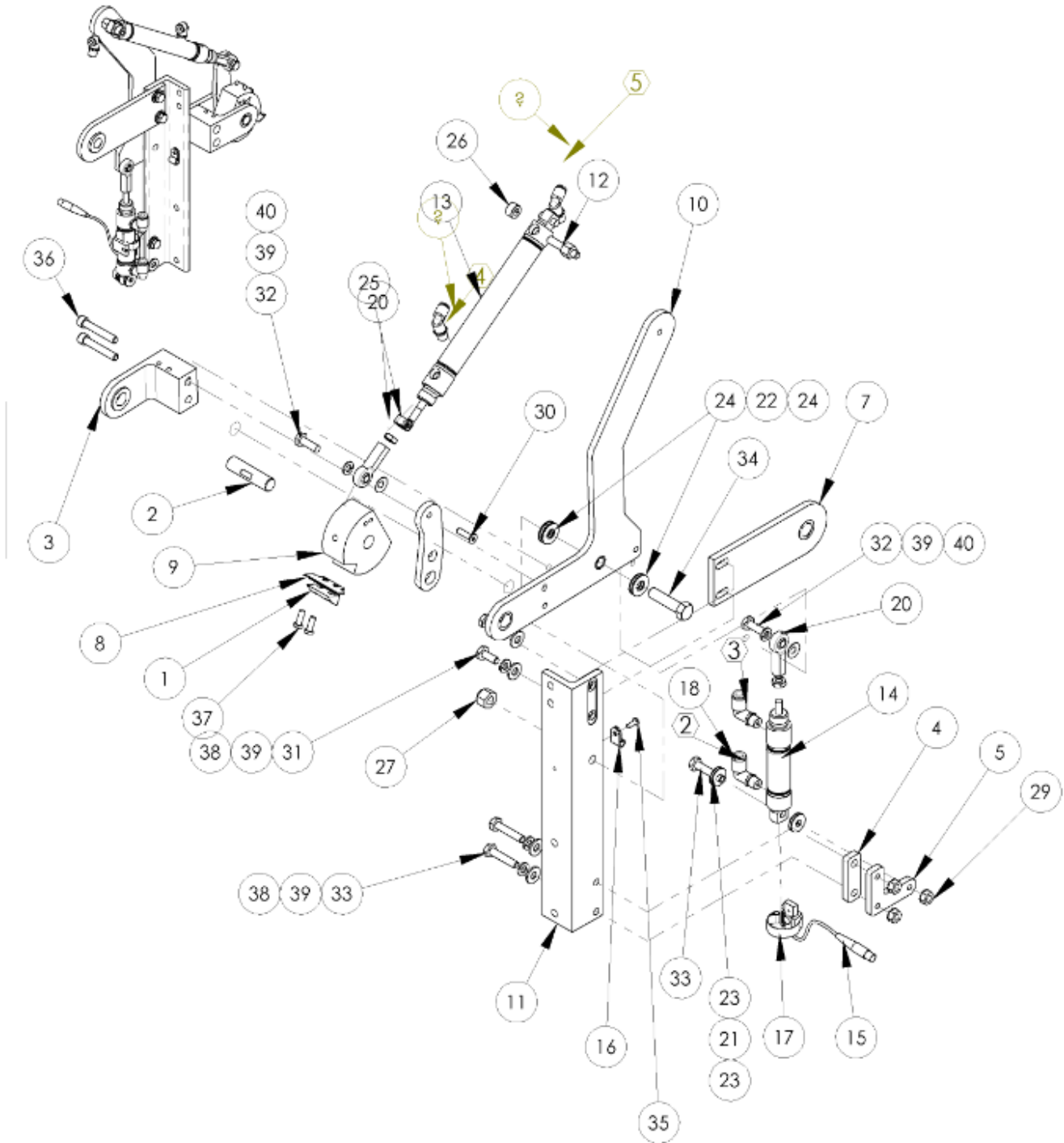

## 1331563 Parts list

ITEM	QTY	PART NUMBER	DESCRIPTION
1	1	1331125	BLOCK, FILLER, PULL WHEEL
2	1	1331204	SHAFT, TENSION WHEEL
3	1	1331205	YOKE, TENSION WHEEL
4	1	1331212	SPACER,1/4X5/8X1.88X1.250
5	1	1331213	BRKT, AIR CYL
6	1	1331287	PIVOT ARM, TENSION ROLLER
7	1	1331312	PLATE, SUPPORT STAPLE
8	1	1331579	BLADE, BORDER TENSION
9	1	1331712	WHEEL, TENSION
10	1	1331714	ARM,TENSION WHEEL
11	1	1331715	TENSION ROLLER MT ANGLE
12	1	1331718	STUD,CYL MTG
13	1	AAC7DP-4R	CYL,AIR,DA,90 DEG PORTS
14	1	AACM040.5-DXP	CYLINDER,AIR,3/4X1/2 STR
15	1	AAEHKQ	SWITCH,HALL EFFECT BIMBA
16	1	AAF3/16	CLAMP, BLACK PLASTIC, 3/16 DIA
17	1	AAFD35000	BAND,UNIVERSAL,AAEHKQ
18	2	AAQME-4-8	QUICK MALE ELBOW, 1/4T
19	2	AAQME-5-8	QUICK MALE ELBOW
20	2	BBAW-4	BEARING,ROD END,FEMALE
21	2	BBNTA411	BEARING,THRUST,.250B
22	2	BBNTA613	BEARING,THRUST,375BORE
23	4	BBTRA411	WASHER,THRUST,STEEL
24	4	BBTRA613	WASHER,THRUST,STL, .375B
25	1	CCCL4F	COLLAR,1/4,CLAMP
26	1	CCSC41/4	COLLAR,SET 1/4"
27	1	NNE3/8-16	NUT, ELASTIC 3/8-16
28	2	NNJ1/4-28	1/4-28 HEX JAM NUT
29	3	NNK1/4-20	KEP NUT, 1/4-20
30	1	SSFC98048	#10-32 X .75 SHCSF
31	2	SSHC01040	1/4-20 X 5/8 HHCS
32	2	SSHC01048	1/4-20 X 3/4 HEX CAP
33	3	SSHC01080	HEX HEAD 1/4-20 X 1-1/4
34	1	SSHC25096	3/8-16 X 1-1/2 HEX HEAD
35	1	SSPS80024	#6-32 X 3/8 LG PAN HD
36	2	SSSC01096	1/4-20 X 1-1/2 SOC CAP
37	2	SSSC98032L	SCREW,SOCKET CAP
38	4	WWFS1/4	WASHER,FLAT,SAE,1/4
39	6	WWL1/4	WASHER,LOCK, 1/4
40	2	WWS307-1	WASHER,SPRING,BELVEL

# 1331565 Square Table lift Assembly (BD)

AAC Drawing Number 1331565 Rev 0

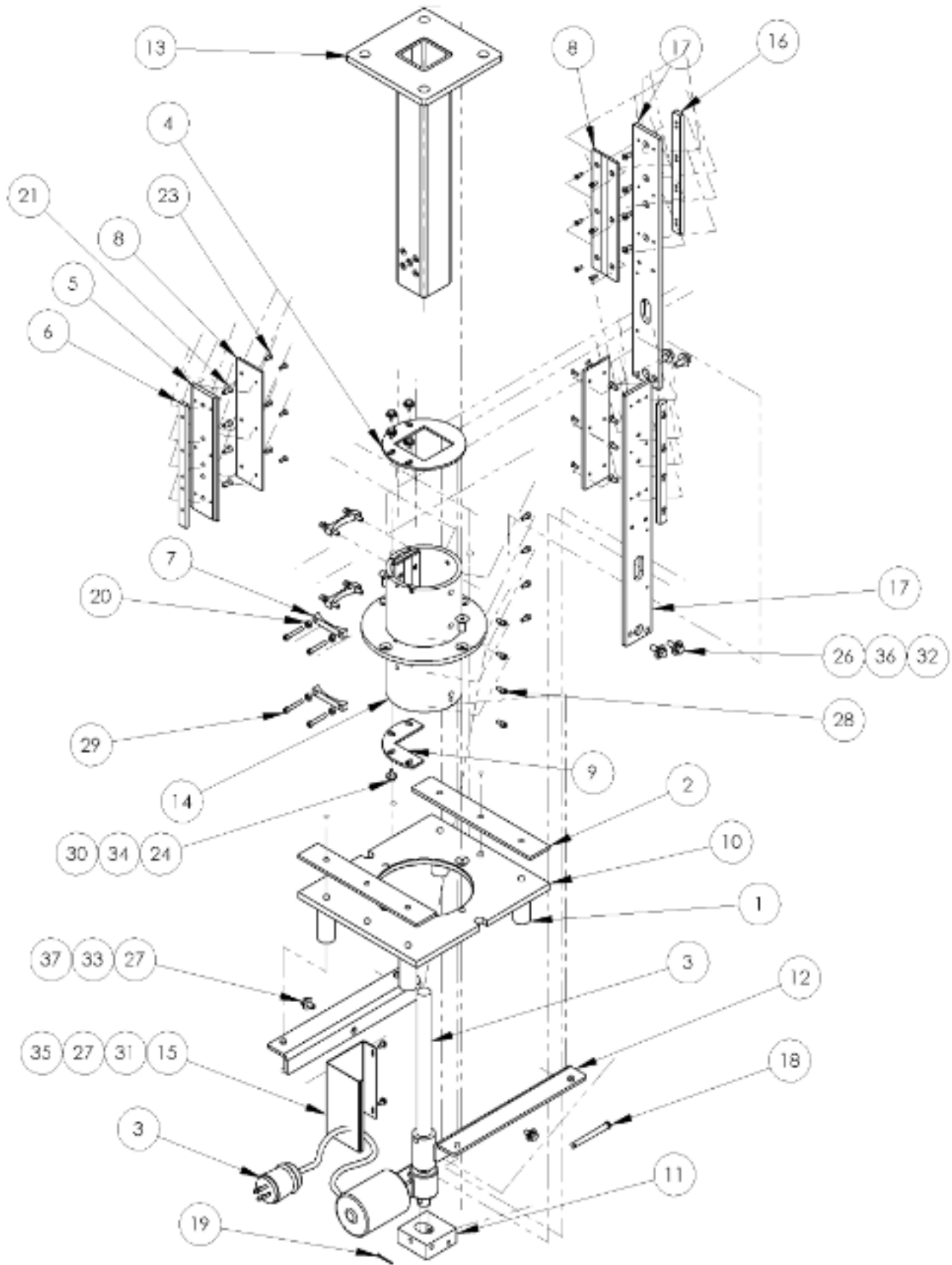

## 1331565 Parts list

ITEM	QTY.	PART NUMBER	DESCRIPTION
1	4	1331114	SPACER,COLUMN HUB SUPPORT
2	2	1331118	WASHER PLATE,COLUMN LIFT
3	1	1345050	ACTUATOR ASSEMBLY,12.5"
4	1	1345093	BKT,EDGE GUIDE
5	2	1345131	PLATE,SLIDE, ADJ
6	2	1345132	BAR, BRACE,.25 THK
7	4	1345134	SPACER,COLUMN CONCAVE
8	4	1345135	PLATE, SLIDE
9	1	1345136	BKT,LOWER GIB STOP
10	1	13451003	PLATE, COLUMN SUPPORT
11	1	13452006B	PLATE, ACTUATOR
12	2	13452008A	SUPPORT, COLUMN HUB
13	1	13452009A	COLUMN.ASSY
14	1	13452020B	COLUMN, HUB ASSY.
15	1	13452023A	COVER, ACTUATOR
16	2	13452040	BAR, BRACE
17	2	13452044A	PLATE,SLIDE SUPPORT
18	1	MM98306A289	PIN,CLEVIS,3/8X3-1/2
19	1	MM98338A445	COTTER PIN, 1/8 X 2 1/2
20	8	NNH1/4-20	NUT,HEX,1/4-20
21	16	SSFC01040	1/4-20 X 5/8 FLAT ALN CAP
22	4	SSFC45064	1/2-13 X 1 SOC FLAT CAP
23	24	SSFC98032	10-32 X 1/2 FLAT ALLEN CAP
24	5	SSHC01040	1/4-20 X 5/8 HHCS
27	2	SSHC10048	5/16-18 X 3/4 HHCS
26	4	SSHC25064	3/8-16 X 1,HEX CAP
27	2	SSHC98032	10-32X1/2 HEX HD
28	8	SSSC01032	1/4-20X1/2 SOC CAP
29	8	SSSC01096F	1/4-20 X 1-1/2 SOC CAP
30	5	WWF1/4	WASHER, FLAT, 1/4", COM
31	2	WWF10	WASHER, FLAT, #10, COM
32	4	WWF3/8	WASHER,FLAT,3/8 OR 10MM
33	2	WWF5/16	WASHER,FLAT,5/16
34	5	WWL1/4	WASHER,LOCK, 1/4
35	2	WWL10	WASHER,LOCK,#10
36	4	WWL3/8	WASHER,LOCK, 3/8
37	2	WWL5/16	WASHER,LOCK, 5/16







## Atlanta Attachment Company (AAC)

### Statement of Warranty Manufactured Products

Atlanta Attachment Company warrants manufactured products to be free from defects in material and workmanship for a period of eight hundred (800) hours of operation or one hundred (100) days whichever comes first. Atlanta Attachment Company warrants all electrical components of the Serial Bus System to be free from defects in material or workmanship for a period of thirty-six (36) months.

#### Terms and Conditions:

AAC Limited Warranty becomes effective on the date of shipment.

AAC Warranty claims may be made by telephone, letter, fax or e-mail. All verbal claims must be confirmed in writing.

AAC reserves the right to require the return of all claimed defective parts with a completed warranty claim form.

AAC will, at its option, repair or replace the defective machine and parts upon return to AAC.

AAC reserves the right to make the final decision on all warranty coverage questions.

AAC warranty periods as stated are for eight hundred (800) hours or one hundred (100) days whichever comes first.

AAC guarantees satisfactory operation of the machines on the basis of generally accepted industry standards, contingent upon proper application, installation, and maintenance.

AAC Limited Warranty may not be changed or modified and is not subject to any other warranty expressed or implied by any other agent, dealer, or distributor unless approved in writing by AAC in advance of any claim being filed.

#### What Is Covered

Electrical components that are not included within the Serial Bus System that fail due to defects in material or workmanship, which are manufactured by AAC are covered for a period of eight hundred (800) hours.

Mechanical parts or components that fail due to defects in material or workmanship, which are manufactured by AAC.

Purchased items (sewing heads, motors, etc.) will be covered by the manufacturers (OEM) warranty.

AAC will assist in the procurement and handling of the manufacturers (OEM) claim.

#### What Is Not Covered

Parts that fail due to improper usage, lack of proper maintenance, lubrication and/or modification.

Damages caused by; improper freight handling, accidents, fire and issues resulting from unauthorized service and/or personnel, improper electrical, plumbing connections.

Normal wear of machine and parts such as Conveyor belts, "O" rings, gauge parts, cutters, needles, etc.

Machine adjustments related to sewing applications and/or general machine operation.

Charges for field service.

Loss of time, potential revenue, and/or profits.

Personal injury and/or property damage resulting from the operation of this equipment.

## TRAINING

Check	Description	Time Hrs.
	<b>Safety Instructions</b>	0.5
	<b>Installation</b> <ul style="list-style-type: none"> <li>• Set up</li> <li>• Power On cycle</li> </ul>	1.5
	<b>Operation</b> <ul style="list-style-type: none"> <li>• Individual components</li> <li>• Serial Bus operator label</li> <li>• Operation Description</li> <li>• With / without dustcover</li> <li>• Maintenance Operator Label</li> </ul>	3
	<b>Service</b> <ul style="list-style-type: none"> <li>• Lock out tag out</li> <li>• Operation sequence Mechanical level</li> </ul>	1
	<b>Mechanical Adjustments</b> <ul style="list-style-type: none"> <li>• Table Adjustments</li> <li>• Tension wheel</li> <li>• Clamp fingers</li> <li>• Staplers</li> </ul>	3
	<b>Pneumatic components</b> <ul style="list-style-type: none"> <li>• Plumbing diagram</li> <li>• FRL unit</li> <li>• Solenoid valve manifold</li> <li>• Pressure adjustments</li> <li>• Pressure switch</li> </ul>	1.5
	<b>Electric component</b> <ul style="list-style-type: none"> <li>• Wiring diagram</li> <li>• Photoelectric Sensor</li> </ul>	1.5
	<b>Serial Bus</b> <ul style="list-style-type: none"> <li>• Touch screen</li> <li>• Modules</li> <li>• Program update</li> <li>• Technical screens</li> </ul>	2
	<b>Maintenance Technical Level</b>	1
	<b>Troubleshooting</b>	0.5
	<b>Evaluate any questions.</b>	0.5

Participants: \_\_\_\_\_  
 \_\_\_\_\_

Instructor: \_\_\_\_\_ Date: \_\_\_\_\_



---

## Notes:



# INDEX

## A

Accessories	10
Advanced Manual	47
Advanced Set Up	46
Air Filters	32
Air Lubricator	32
Air Pressure Module	40
Air Pressure Switch	33
Alignment and Leveling	29
<b>ARROWS</b>	18
Automatic Staples	14, 16
Available Menus	19

## B

Border Clamp Fingers	30
Bypass Valve	31

## C

Calibration	37
<b>CLOCK</b>	18
Column Lift	29
Control Panel	15

## D

Data Module	40
-------------	----

## E

Electric Eyes	13
Electrical	0, 27, 34, 40, 115
Emergency Stop	15, 17
EXP CODE	43
Expiration Count 911	42

## F

Firing Cylinder	31
First Aid	2

## G

General Operation	17
Ground	34

## H

<b>HOME</b>	18
-------------	----

## I

Input Module	40
INSTALLATION	8
Installing New Screen	38

## L

Lift Table Pedals	15
Lockout/Tagout Program	27

## M

Main Circuit Breaker	34
Main Power Contactor	34
Maintenance	25, 27, 32, 49
Maintenance 40 Hrs	50
Maintenance 8 Hrs	26
Maintenance 960 Hrs	51
Manual Staple	14, 16
MECHANIC SECURITY SCREEN	43
Mechanical Adjustments	29, 116
Modules	40

## N

Navigation	18
------------	----

## O

OPERATION	14
Operation Sequence	28
Output Module	40

## P

Parts and Components	8
<a href="#">Patents &amp; Patents Pending</a>	0
PAUSED	19
Pedal	13
Photoelectric Sensors	34
<b>PIECE COUNT</b>	18
PIECE COUNTER	19
Pneumatic	0, 6, 27, 32
Power "ON"	15

Pressure Regulator	32
Pressure Relief	32
Pressures Adjustments	33
Program Update	41
Proximity Eyes	16

## R

READY SEMI-AUTOMATIC	19
READY- TRAINING	19
Reloading the Staplers	23
Replacing a Module	40
<b>RESET</b>	18, 38, 43
Reset Staple Left	20
Rotation Plate Pedal	14, 15

## S

Screen Error Messages	52
SECURITY	20
Serial Bus	15, 37, 115
Serial Number	11
SERVICE	27
Set up Screen	20
Show All Settings	45
Solenoid Valve	33
Standard Modules	40
Staplers	30
Stapling Cycle	21, 22
STAPLING FOUNDATION	19
Startup Sequence	17
Statement of Warranty	115
System Information	45
SYSTEM INFORMATION	20

## T

Table	29
Technical Data	9
Technical Screens	44
Tension Wheel	29, 33
Touch Screen	8, 37
Touch-Screen	17
TRAINNING	116
Troubleshooting	52
types of staples	24

## U

Update Controller	41
-------------------	----





Atlanta Attachment Company Inc.  
362 Industrial Park Drive  
Lawrenceville, GA 30046  
Phone: +1 (770) 963-7369  
[www.atlatt.com](http://www.atlatt.com)

**Printed in USA**  
Digital Version of this Manual Available at:  
[http://atlatt.com/tech\\_manuals.php](http://atlatt.com/tech_manuals.php)