

100
101
102
103
104
105
106
107
108
109
110
111
112
113
114
115
116
117
118
119
120
121
122
123
124

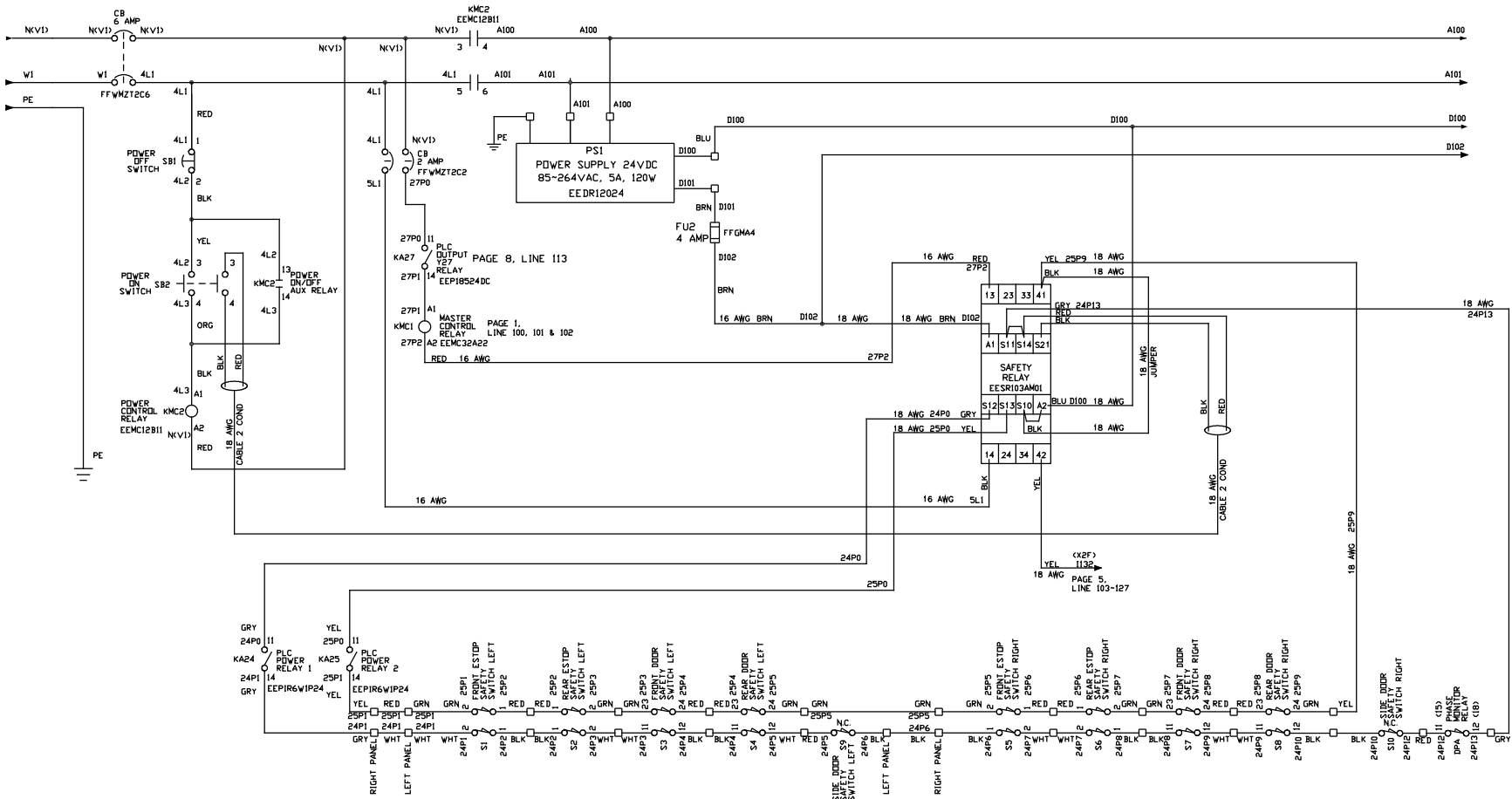

021-07

NO.	REVISION	DATE	DR.	CK.
	FINISH			
	PLAIN / CLEAN			
	BURR BENCH			
	BLACK OXIDE			
	HEAT TREAT			
	SAND BLAST			
	BUFF			
	PAINT			
	CLEAR CHROMATE	.X	= ± .100	
	TIMESAVE	.XX	= ± .050	
	OIL	.XXX	= ± .015	
		.XXXX	= AS SPECIFIED	

QTY. REQD.	ITEM NO.	DESCRIPTION	PART NO. STOCK
ATLANTA ATTACHMENT COMPANY			
NAME DIAGRAM, WIRING, PAGE 3			
2nd DES. START, STOP, SAFETY, & DC CIRCUIT, 1393E			
MATERIAL N/A			
NEXT ASSY 11393E		PART NO. 1393E-WD3	
DES. BY JSK		DRAWING NO.	
DR. BY JSK		125886B	
CK. BY		REV 2	
SCALE		DATE: 10-20-10	DWG SIZE B

The materials contained herein are confidential and proprietary information of Atlanta Attachment Company. In addition to any confidentiality and non-disclosure obligations that currently exist between you and Atlanta Attachment Company, your use of these materials serves as an acknowledgment of the confidential and proprietary nature of these materials and your duty not to make any unauthorized use or disclosure of these materials.

102
103
104
105
106
107
108
109
110
111
112
113
114
115
116
117
118
119
120
121
122
123
124

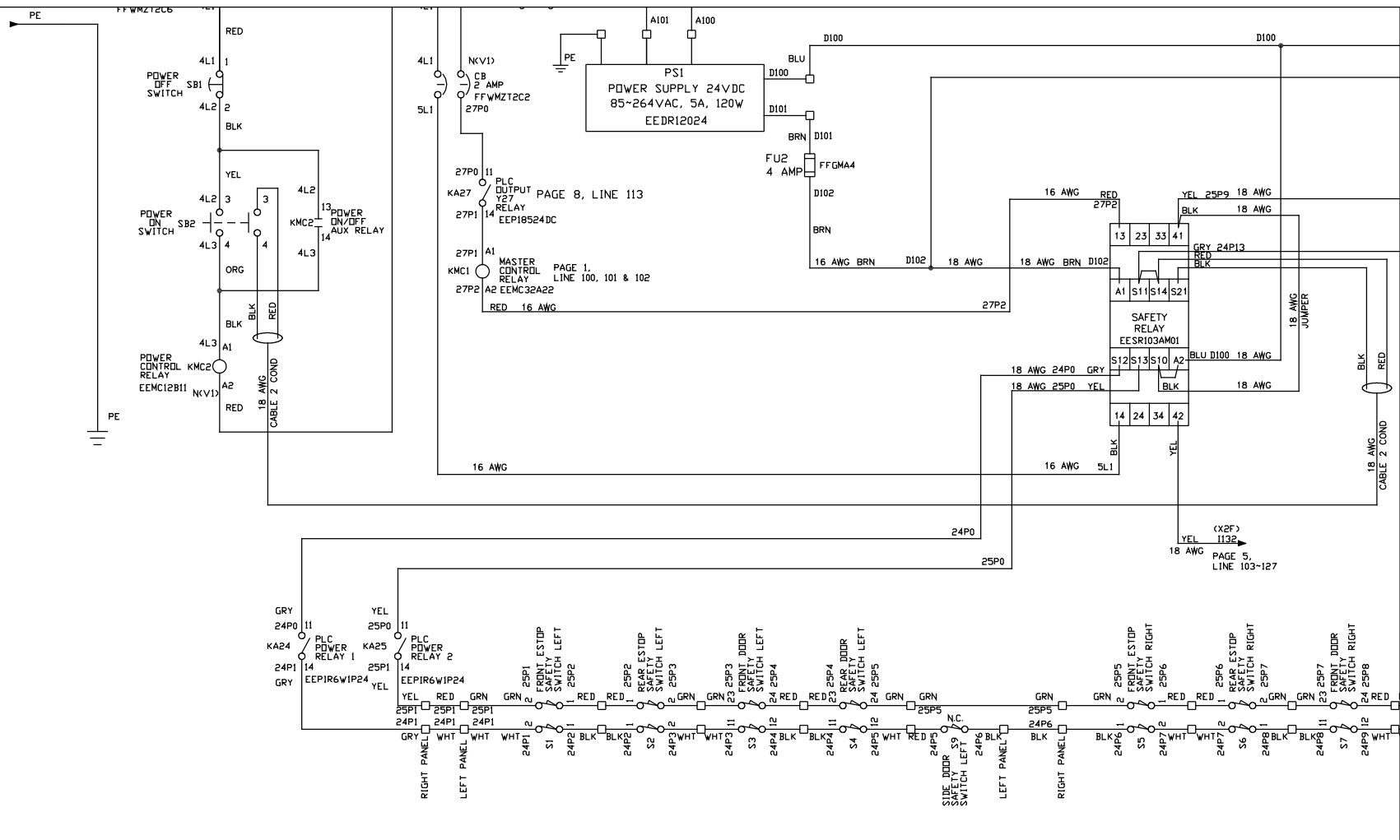

021-07

NO.	REVISION	DATE	DR.	CK.	QTY. REQD.	ITEM NO.	DESCRIPTION
					ATLANTA ATT		
					NAME DIAGRAM, WIRING		
					2nd DES. START, STOP, S		
					MATERIAL N/A		
					NEXT ASSY 11393E		
					DES. BY JSK		
					DR. BY JSK		
					CK. BY .		
					SCALE		DATE: 10-2

The materials contained herein are confidential and proprietary information of Atlanta Attachment Company. In addition to any confidentiality and non-disclosure obligations that currently exist between Atlanta Attachment Company and your company, your use of these materials serves as an acknowledgment of the confidential and proprietary nature of these materials and your duty not to make any unauthorized use or disclosure of